

# Russian MiG-31 Foxhound

ロシア MiG-31 フォックスハウンド MiG-31 “捕狐犬”

## PLEASE READ BEFORE OPERATION!

- ★ Tools recommended as below: (Not included)  
Adhesives; Paints; Side Cutters; Sharp Edged Pliers; Modeling Knife; Modeling File; Nippers; Drill; Scissors; Sand Paper; Soft Cloth; Cyanoacrylate Glue.
- ★ Make sure to read this instruction listed below before assembling.
- ★ The kit contains the small parts, they can be dangerous if swallowed by mistake, so keep them away from reach of children.
- ★ Cut the all parts off carefully and remove the waste parts into the garbage can.
- ★ More caution and care should be needed for cutting and handling the photo etched parts.
- ★ Make attention that some parts should be attached the decal when assembled.
- ★ During assembling, please tear up and throw away the plastic bags, or may cause the dangerous if wearing over head by children's mistake.
- ★ When using the adhesives and paints, please do not use them in the closed room or near the fire, also must be very careful to protect your eyes, face and clothes.
- ★ Adult supervised when assembled by children under 14 years old.

## 装配前请仔细阅读：

- ★ 推荐使用的模型工具(请自备):  
专用模型胶水, 专用模型油漆, 水口剪刀, 长咀钳, 刀片, 锉刀, 镊子钳, 钻, 剪刀, 软布, 砂纸, 瞬间快干胶等。
- ★ 用水口剪刀或刀片小心切下所有塑胶零件和蚀刻片零件, 不要遗失小零件。
- ★ 切取蚀刻片时应特别注意防止利刃划伤手指。
- ★ 用模型锉刀小心锉平所有零件表面的注射浇口。
- ★ 用适量的强力快干胶水粘合蚀刻片零件和金属轴, 切忌过量, 否则可能导致可动零件被粘住。
- ★ 注意某些零件表面需在装配时同步贴水上贴纸。
- ★ 制作时应远离幼儿并将包装袋及时收妥, 谨防小孩玩耍而引起意外。



using ca super glue  
使用强力胶



weight  
配重



make hole  
钻孔



cut / remove  
切除



option  
选择



no cement  
不涂胶水



decal  
贴纸



bend  
弯曲



repair  
填补



install it first  
先装

## The method to apply the decals

1. Cut off the decal from the decal paper and put it into the warm water 40°C for 10 seconds.
2. Take the decal from the water and put it on a piece of clean cloth.
3. Remove the decal slowly from the paper to the targeted location by a wet finger.
4. Use a piece of dry and soft cloth to press it gently on the decal until it getting dry and no bubble existing.

## 水贴纸的使用方法：

- 一. 把相关的印花从水贴上剪下, 放入40°C左右的温水中浸10秒。
- 二. 然后将印花放在干净的布上。
- 三. 拿上印花纸板, 手指蘸水将印花移到适当的位置。
- 四. 用软干布轻压印花直至水干, 气泡消失。

部品图 Parts

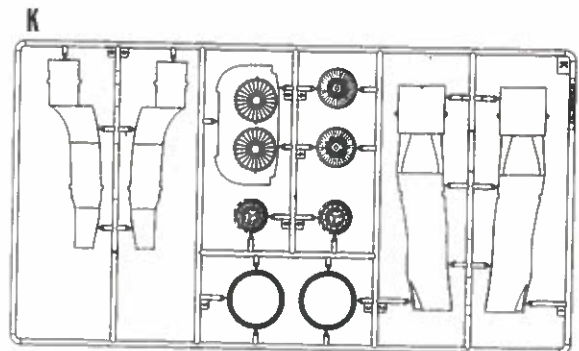
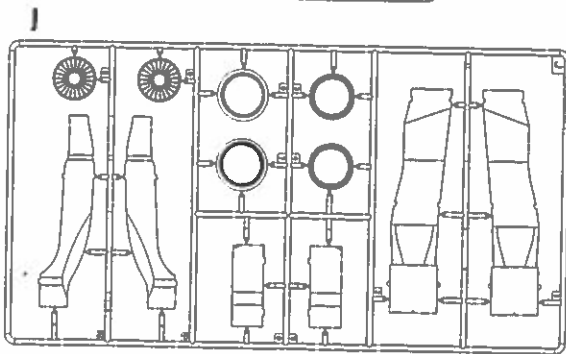
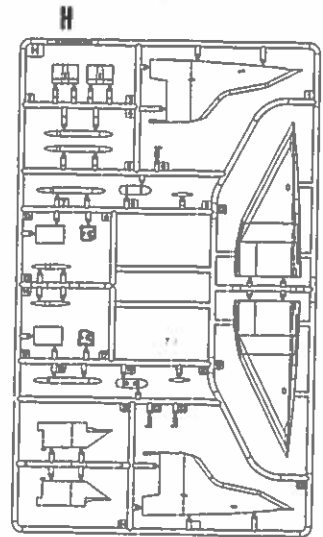
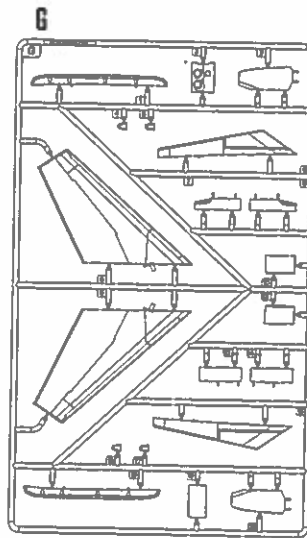
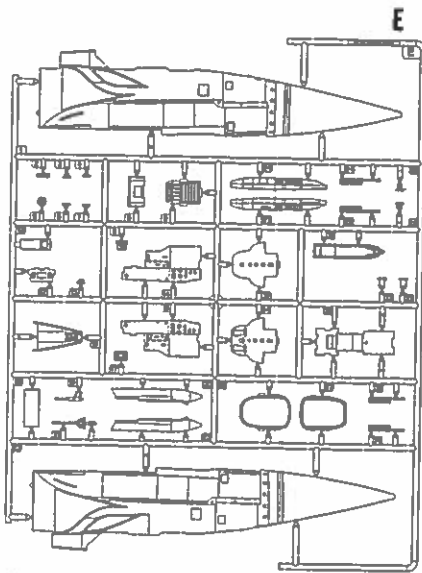
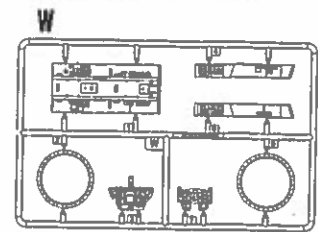
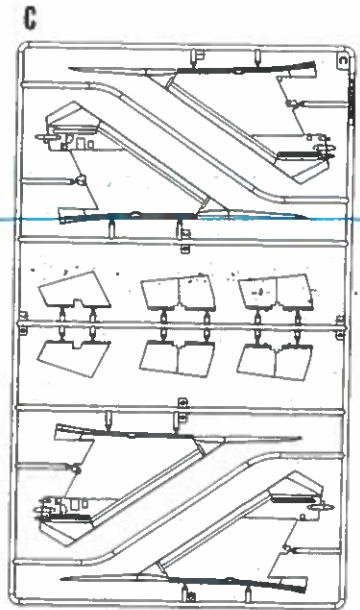
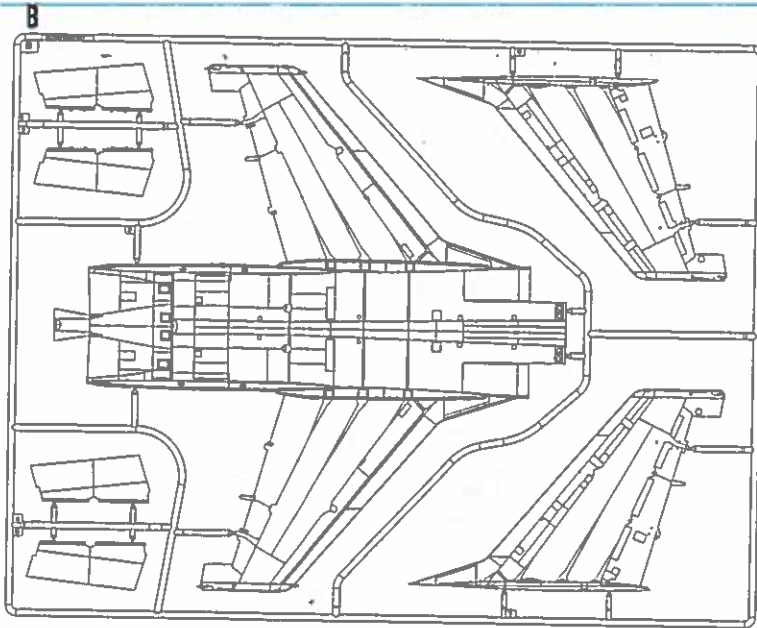
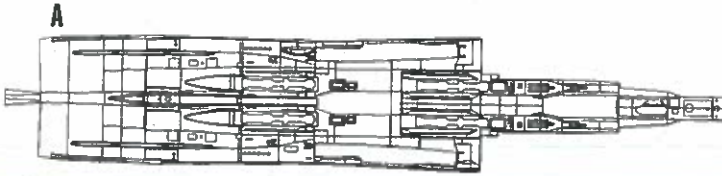

部品图 Parts

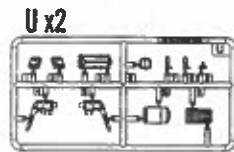
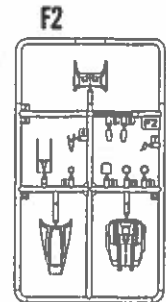
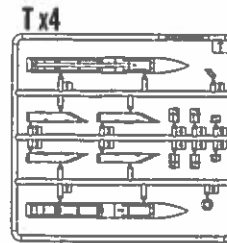
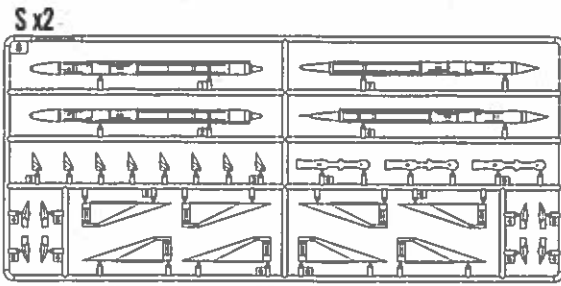
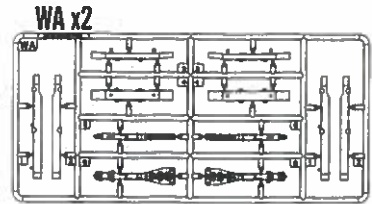
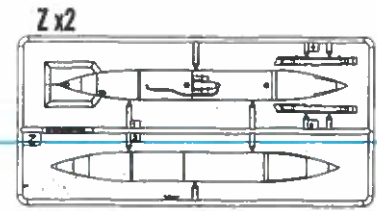
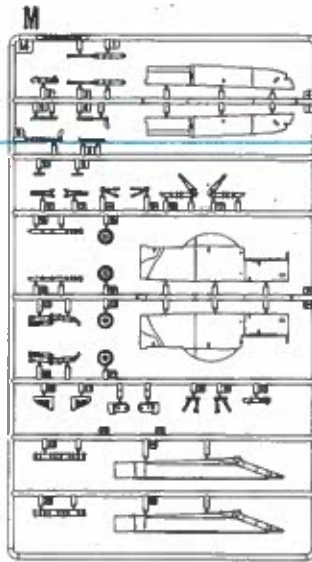
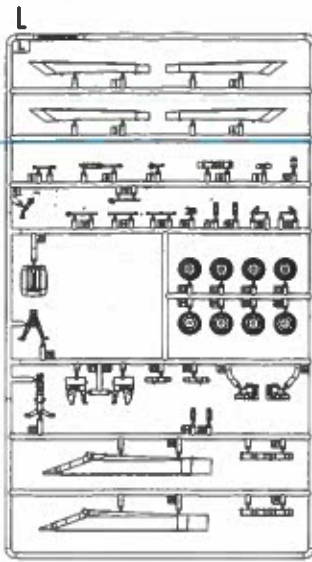

《金属部件》  
Metal parts

- |    |  |    |  |
|----|--|----|--|
| #3 |  | #1 |  |
| #4 |  | #5 |  |
| #2 |  | #6 |  |
|    |  | #7 |  |

《蚀刻片》- A  
Photo etched parts(PE)



《蚀刻片》- B  
Photo etched parts(PE)

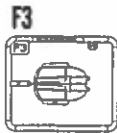

《前轮胎》x2  
Nose tyre



《主轮胎》x4  
Main tyre



《水贴》A  
Decal A



《水贴》B  
Decal B

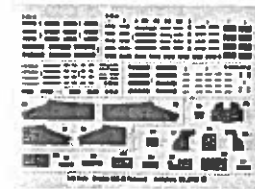

不用的部件: E5 K3 K7 F4 F7 L34 L35 M10 M11  
Unused parts PEA1 PEA3 PEA13

1 STEP

H 81 55 《座舱》  
卡其色  
Khaki  
Cockpit

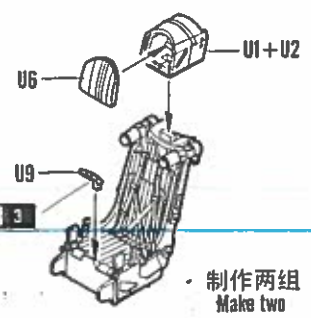
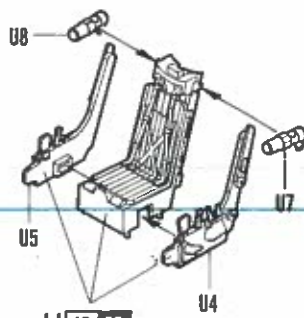
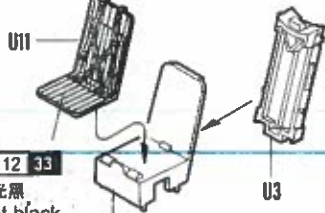

H 12 33  
消光黑  
Flat black

H 3 3  
红色  
Red

制作两组  
Make two

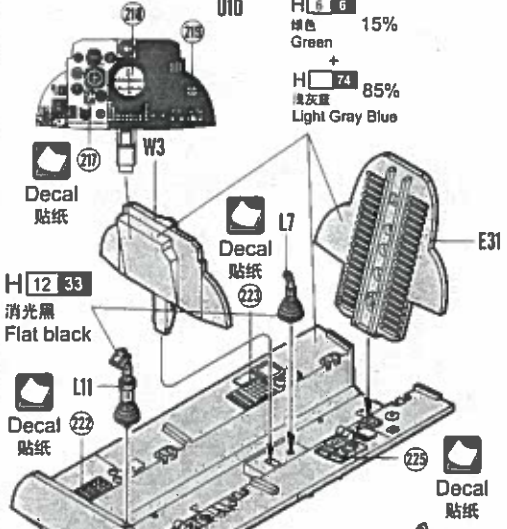

H 6 6  
绿色  
Green 15%  
+  
H 74 85%  
浅灰蓝  
Light Gray Blue

H 12 33  
消光黑  
Flat black

Decal 贴纸 216  
E17

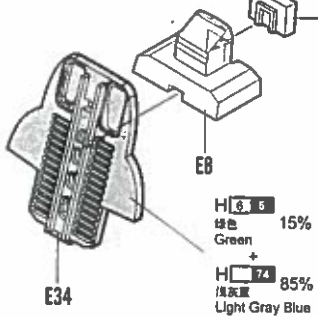
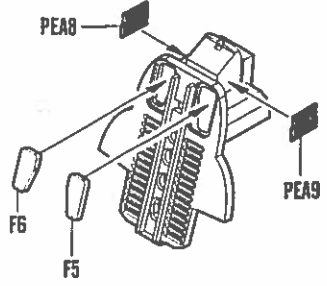

H 6 6  
绿色  
Green 15%  
+  
H 74 85%  
浅灰蓝  
Light Gray Blue

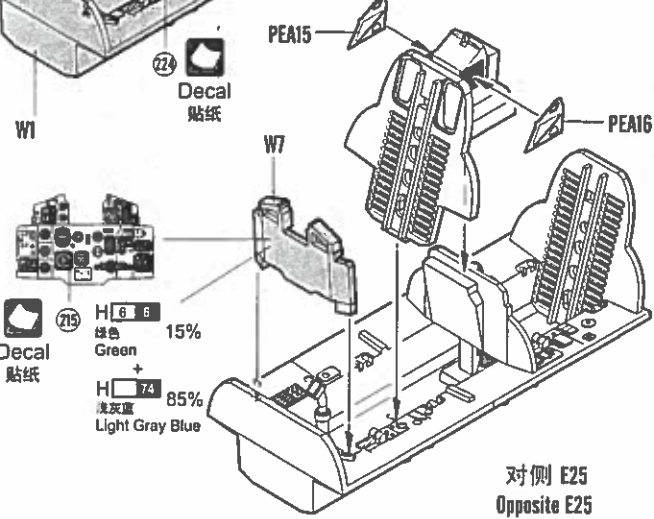
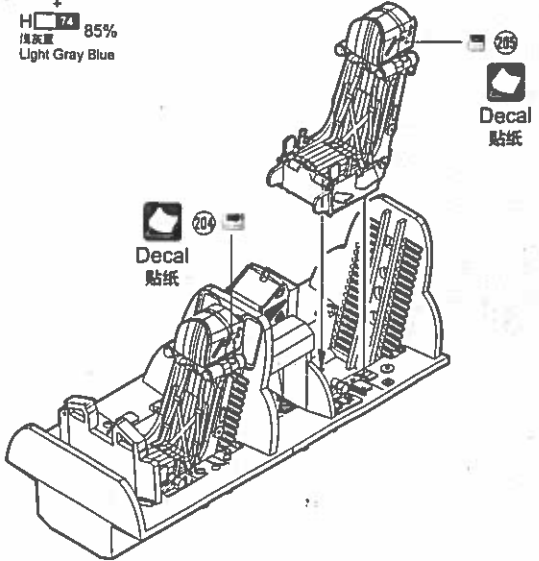

Decal 贴纸 215  
H 6 6  
绿色  
Green 15%  
+  
H 74 85%  
浅灰蓝  
Light Gray Blue

对侧 E25  
Opposite E25  
E28

对侧 E38  
Opposite E38  
E39

舱盖闭合状态时不装 E25 E28 E38 E39  
The hatch closed state does not need to install E25 E28 E38 E39

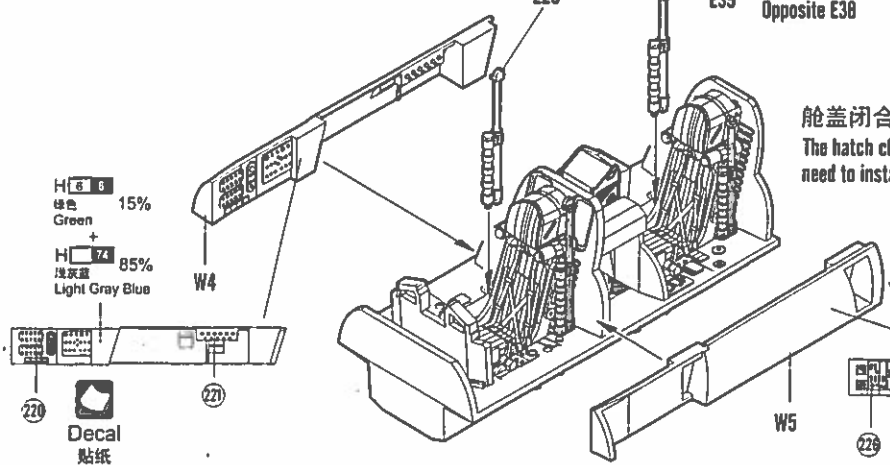

H 6 6  
绿色  
Green 15%  
+  
H 74 85%  
浅灰蓝  
Light Gray Blue

H 6 6  
绿色  
Green 15%  
+  
H 74 85%  
浅灰蓝  
Light Gray Blue

Decal 贴纸

2  
STEP 2

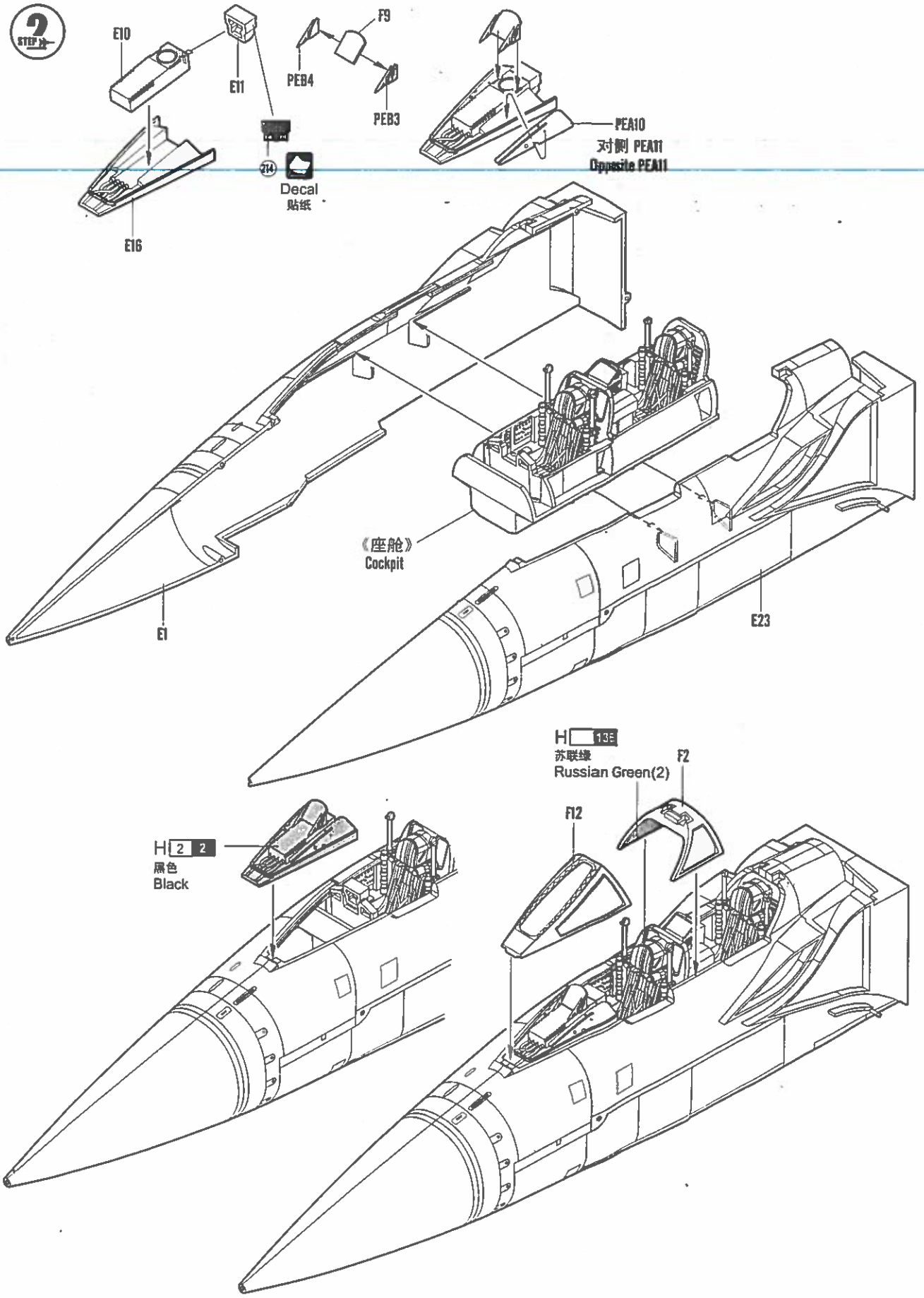

2  
STEP 2

《左侧进气道》  
Left air intake

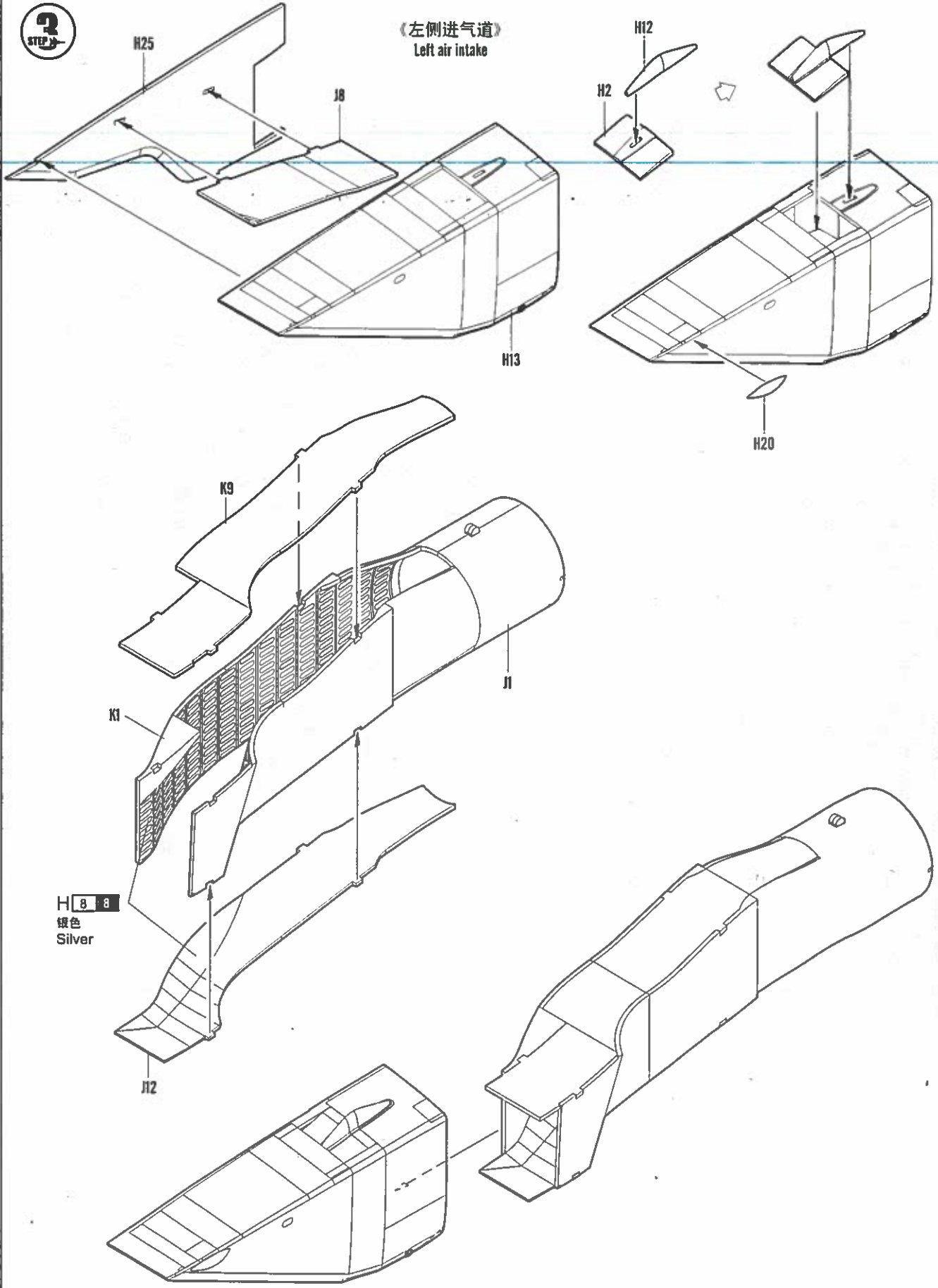

H 8 8  
银色  
Silver



《右侧进气道》  
Right air intake

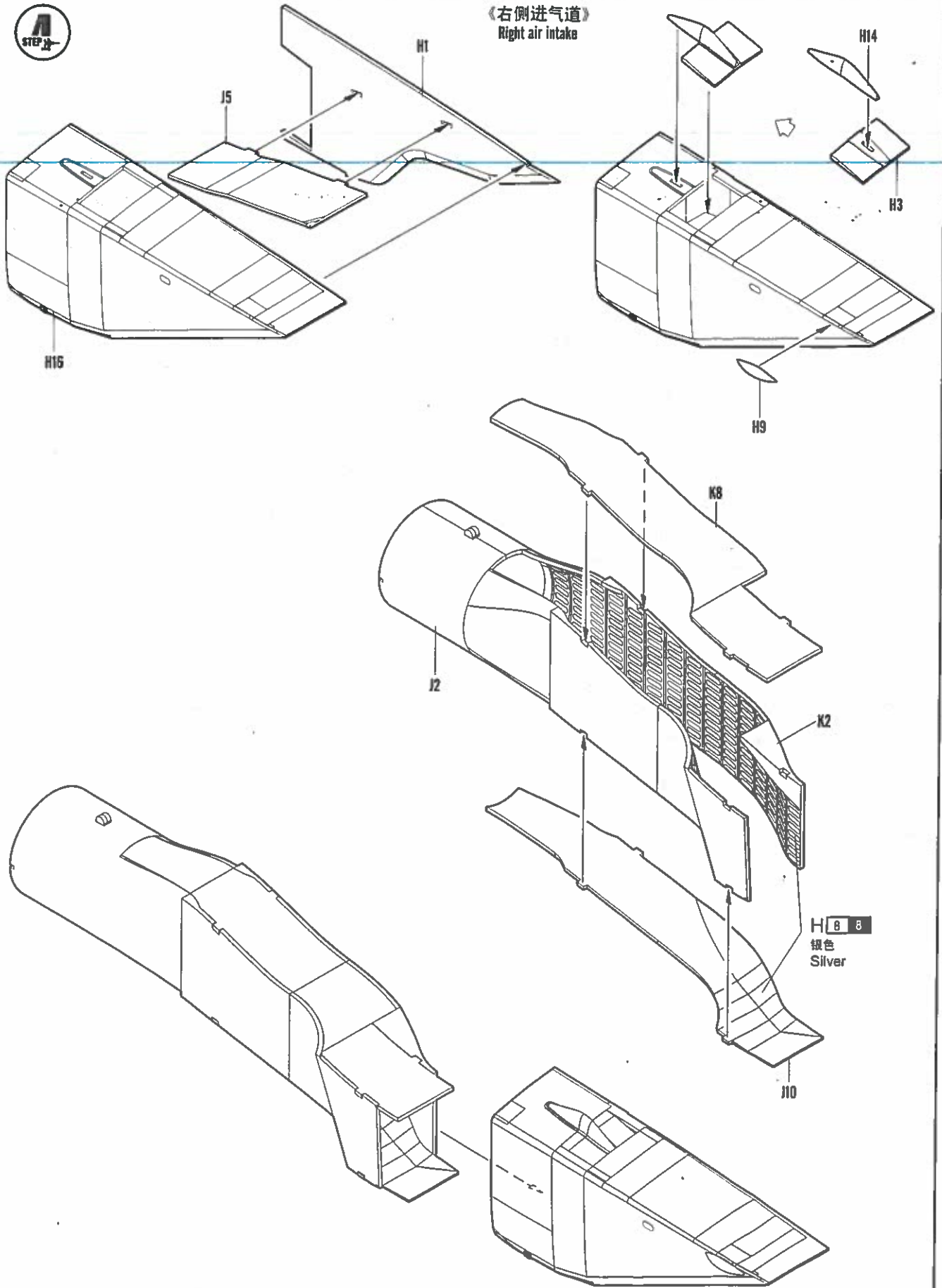

5 STEP

《金属部件》3#  
Metal part

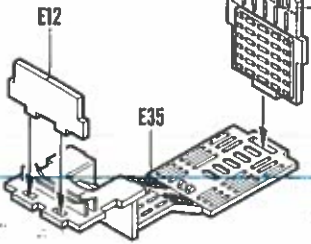
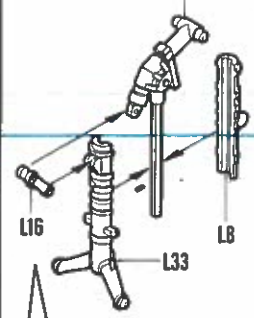

《前轮舱》  
Nose gear cabin

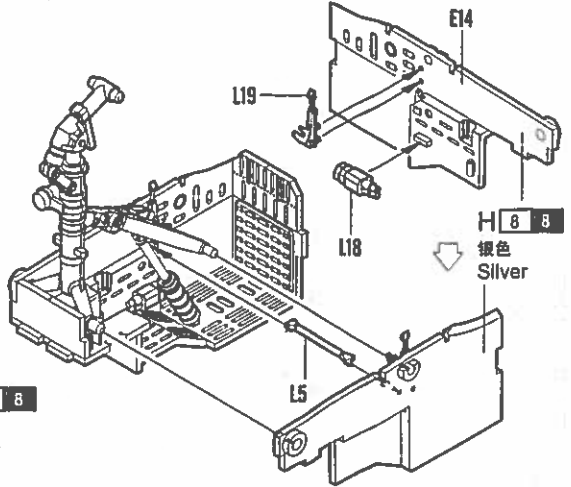
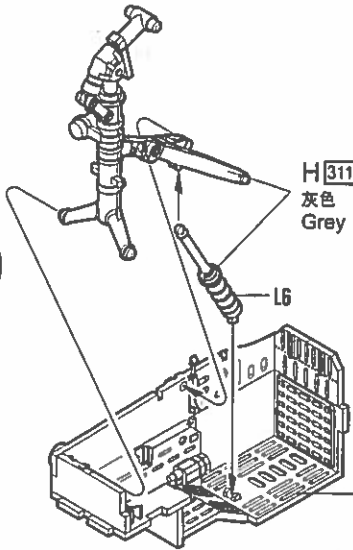
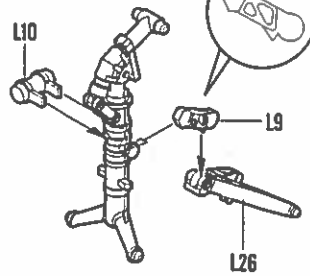
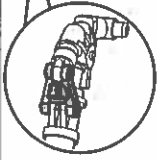
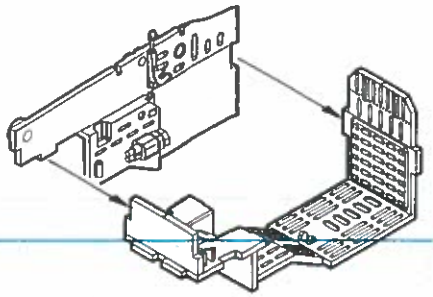
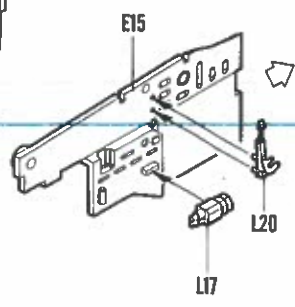

6 STEP

《左侧主轮舱》  
Left main gear cabin

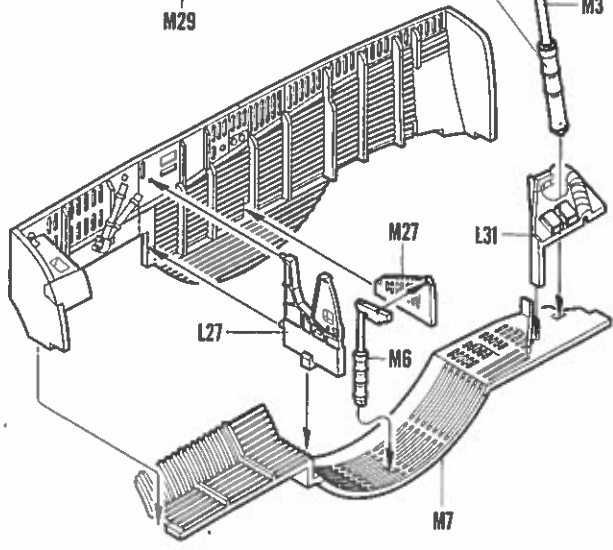
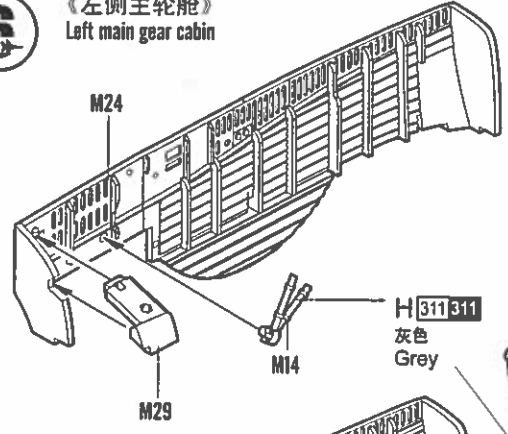

7 STEP

《右侧主轮舱》  
Right main gear cabin

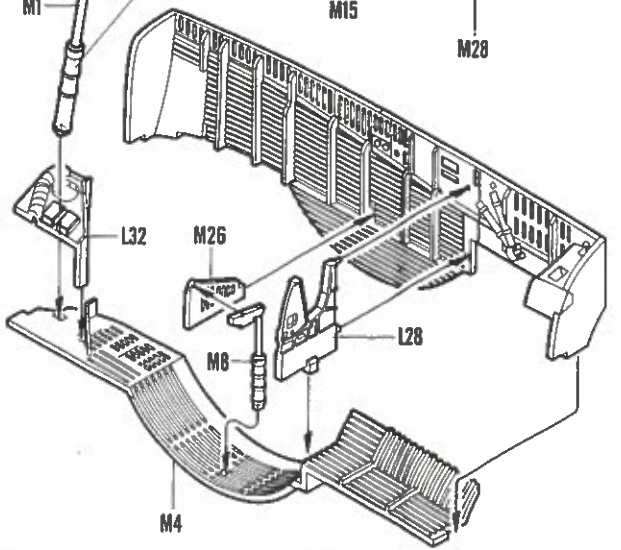
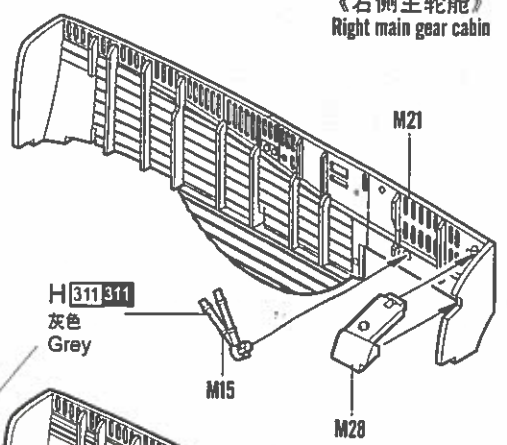





《右侧主轮舱》  
Right main gear cabin

《左侧主轮舱》  
Left main gear cabin

《前轮舱》  
Nose gear cabin

E18

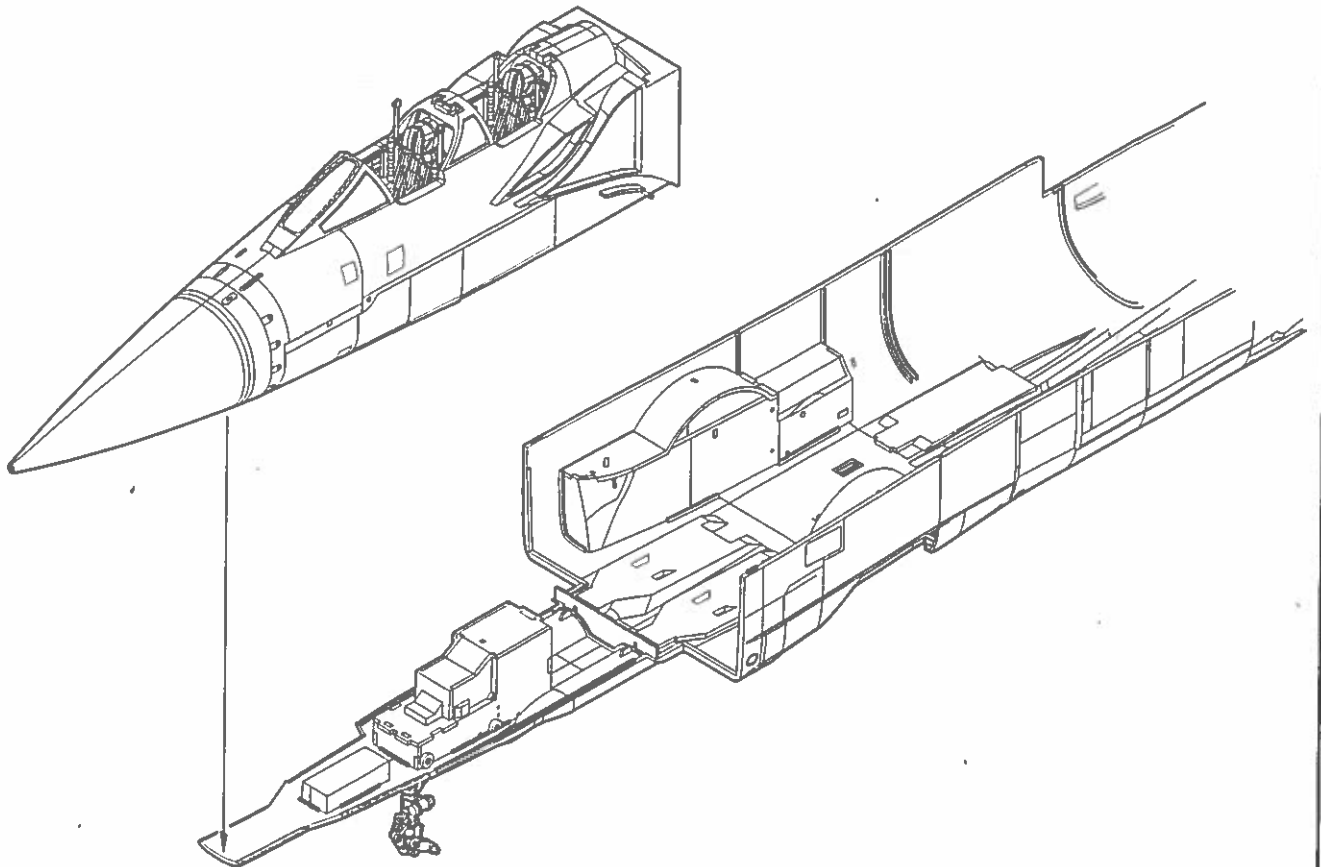



H 76 61  
烧铁色  
Burnt Iron

K6

川

《右侧进气道》  
Right air intake

19

《左侧进气道》  
Left air intake

对侧 H17  
Opposite H17  
H11

对侧 B7  
Opposite B7  
B6

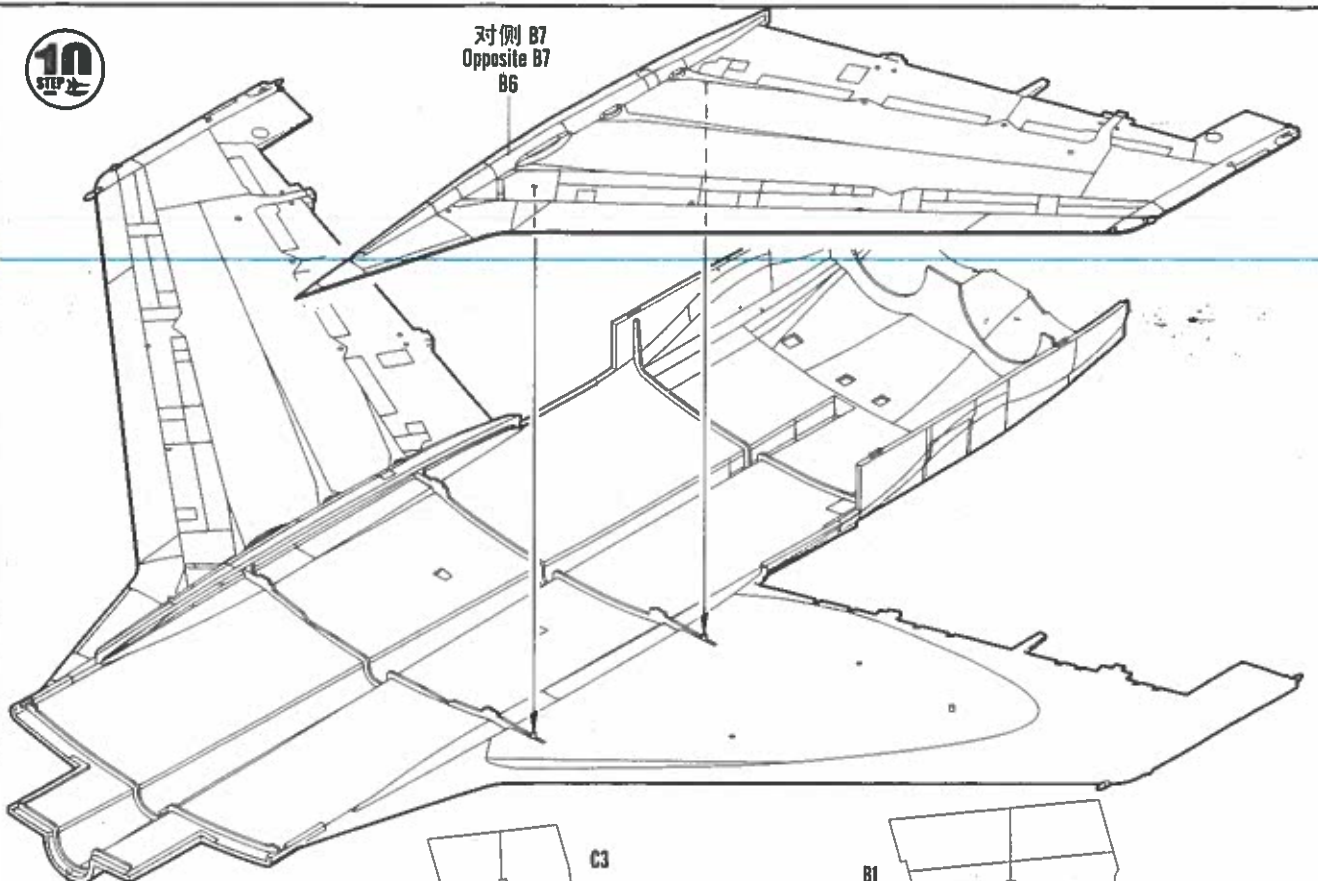

B3

打开状态时切除  
Cut when open

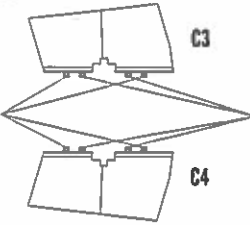

闭合状态时切除  
Cut when close

B1

B2

打开状态时切除  
Cut when open

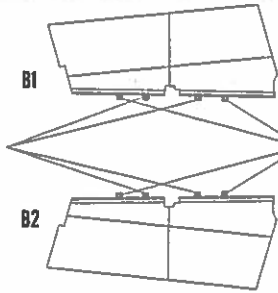

对侧 C4 + C5  
Opposite C4 + C5  
C3 + C6

对侧 B1 + B4  
Opposite B1 + B4  
B2 + B5

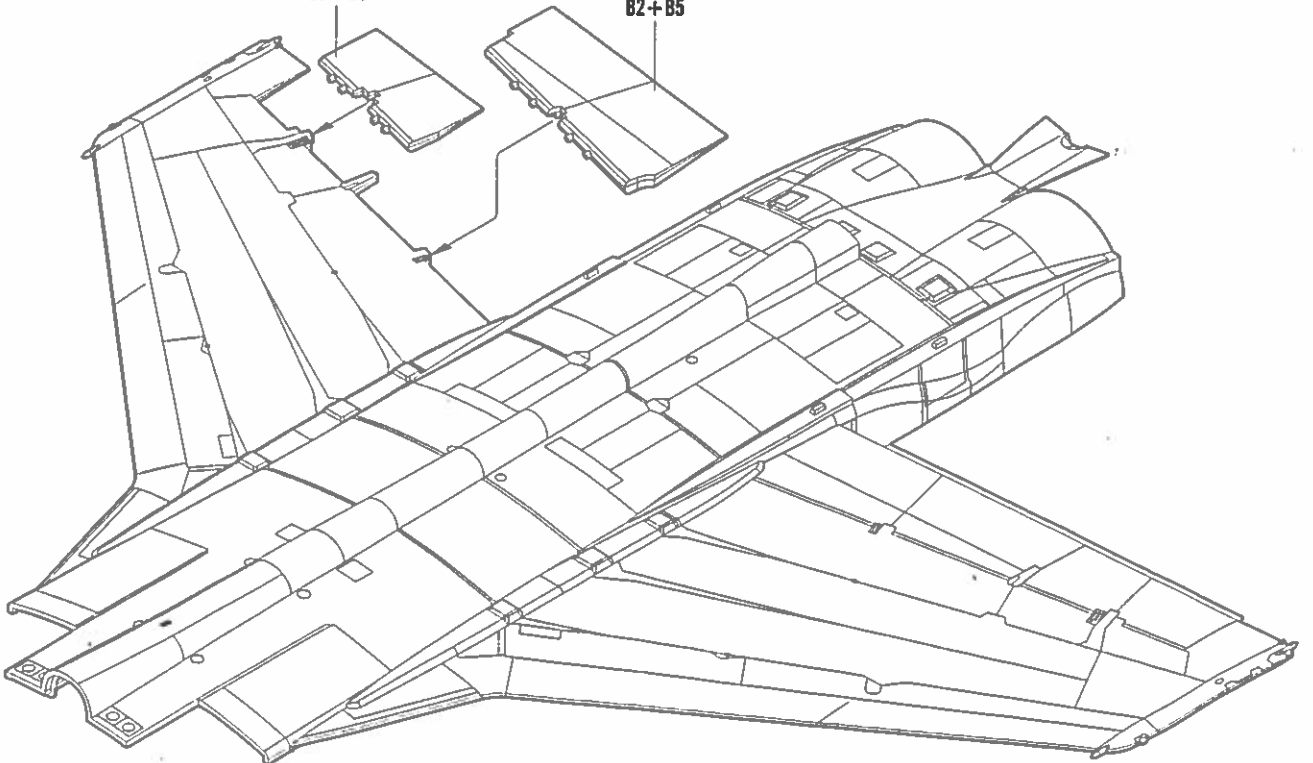

11  
STEP 11

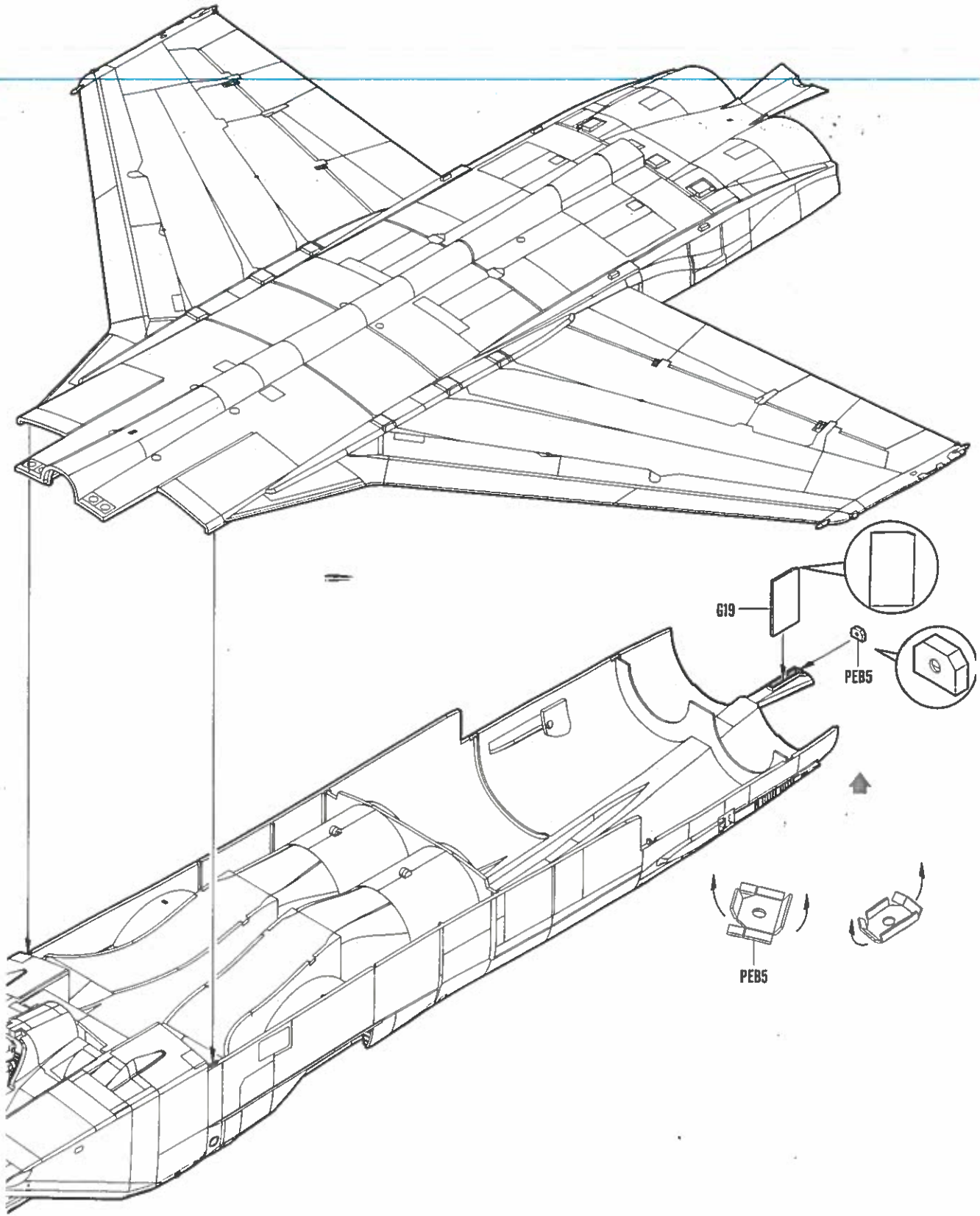

《尾喷管》  
Tail spout

H 76 G1  
烧铁色  
Burnt Iron

制作两组  
Mak two

H 136  
苏联绿  
Russian Green(2)

H 136  
苏联绿  
Russian Green(2)

W2  
(W6)

J6  
(J7)

J3  
(J4)

《尾喷管》  
Tail spout

E20+E22

E30

G9  
对侧 G11  
Opposite G11

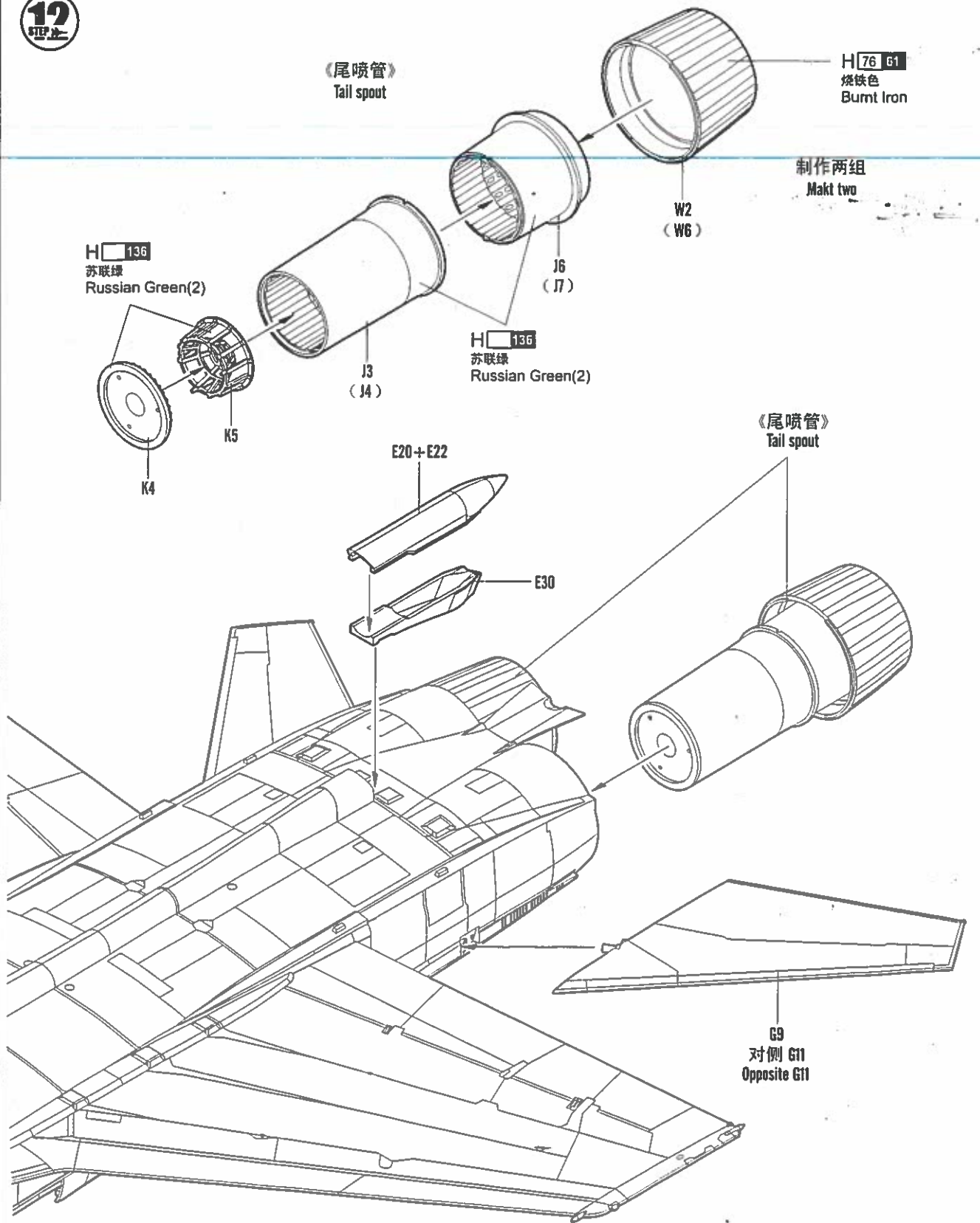

13  
STEP

《右侧垂翼》  
Right vertical stabilizer

《左侧垂翼》  
Left vertical stabilizer

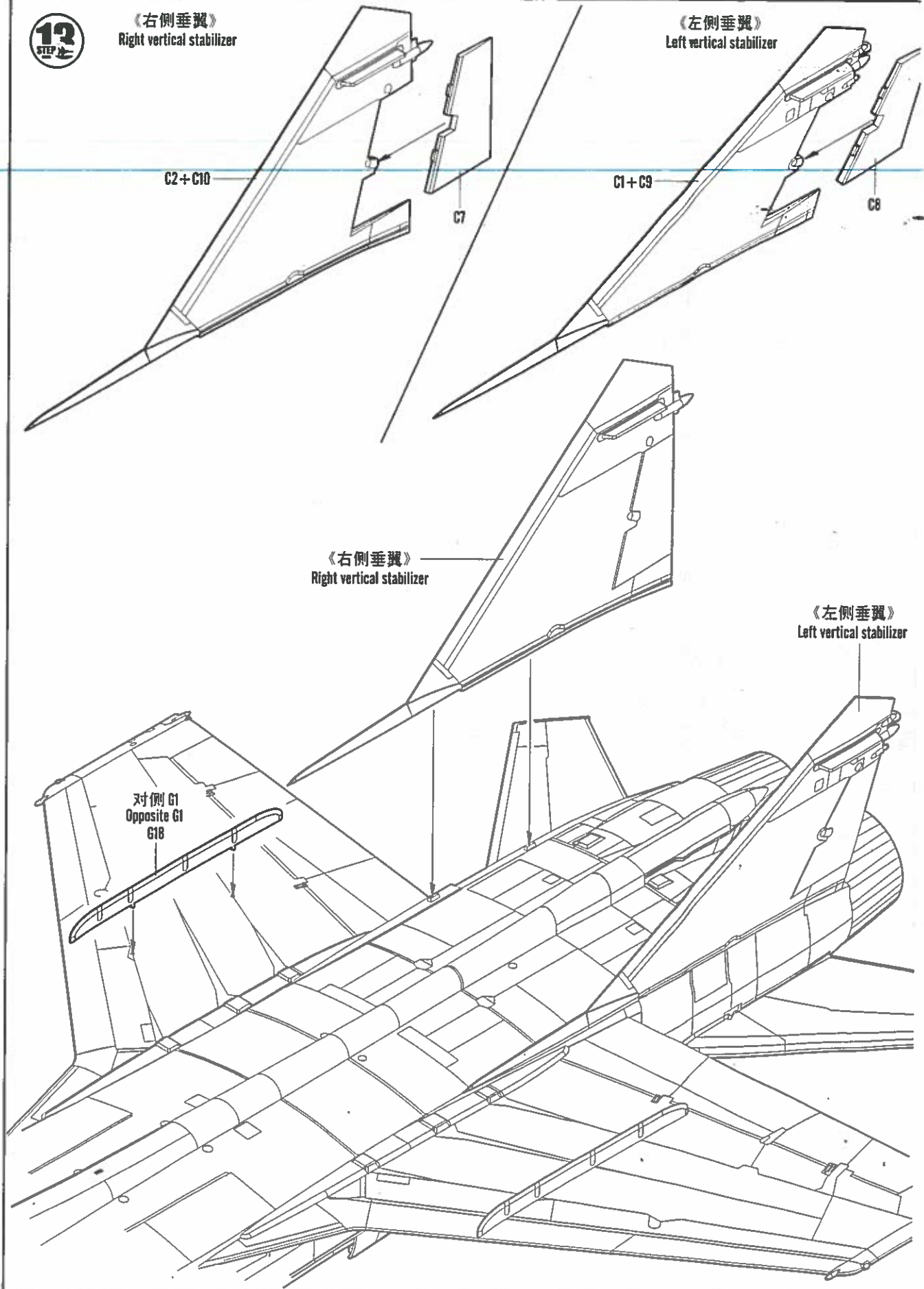

1A  
STEP 2

《A-A》

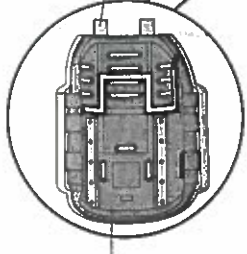
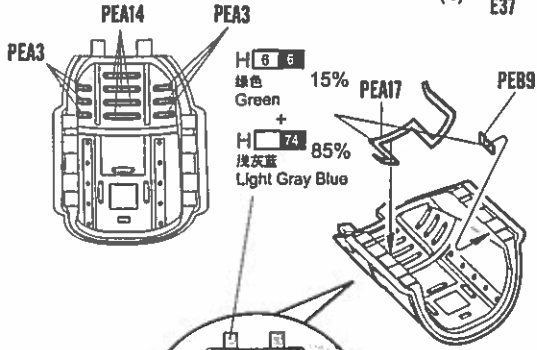
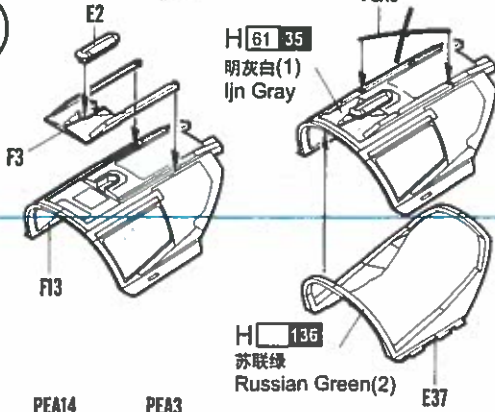

H 136  
苏联绿  
Russian Green(2)

《B-B》

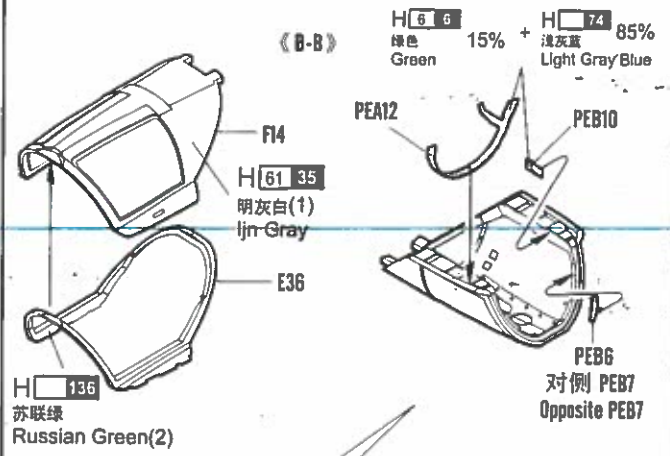

H 136  
苏联绿  
Russian Green(2)

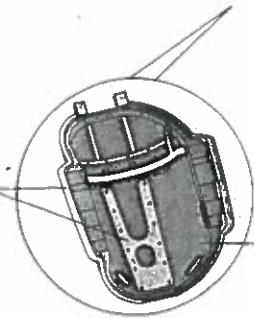

H 136  
苏联绿  
Russian Green(2)

《A-A》

《B-B》

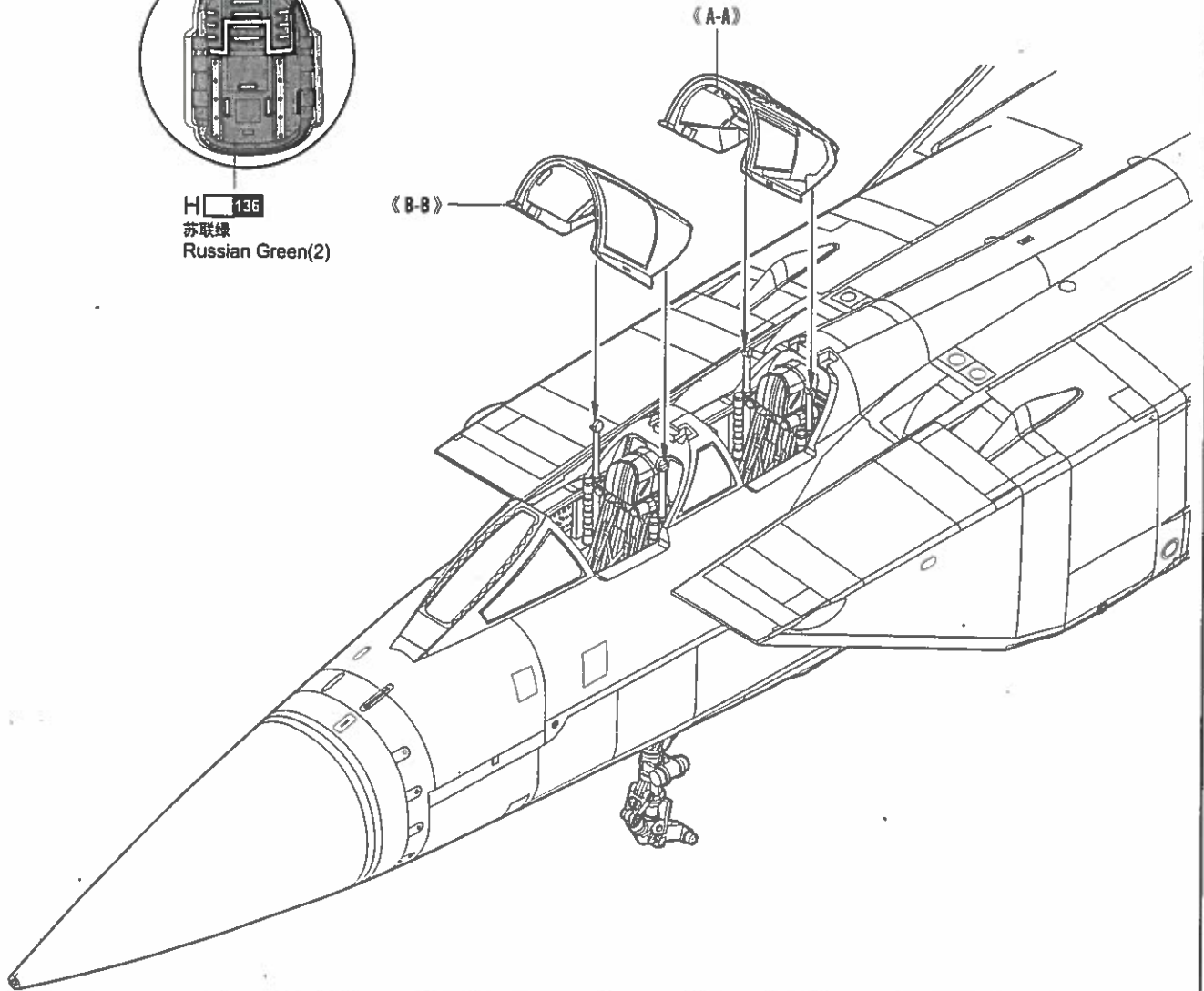

15  
STEP 15

《左侧起落架》  
Left undercarriage

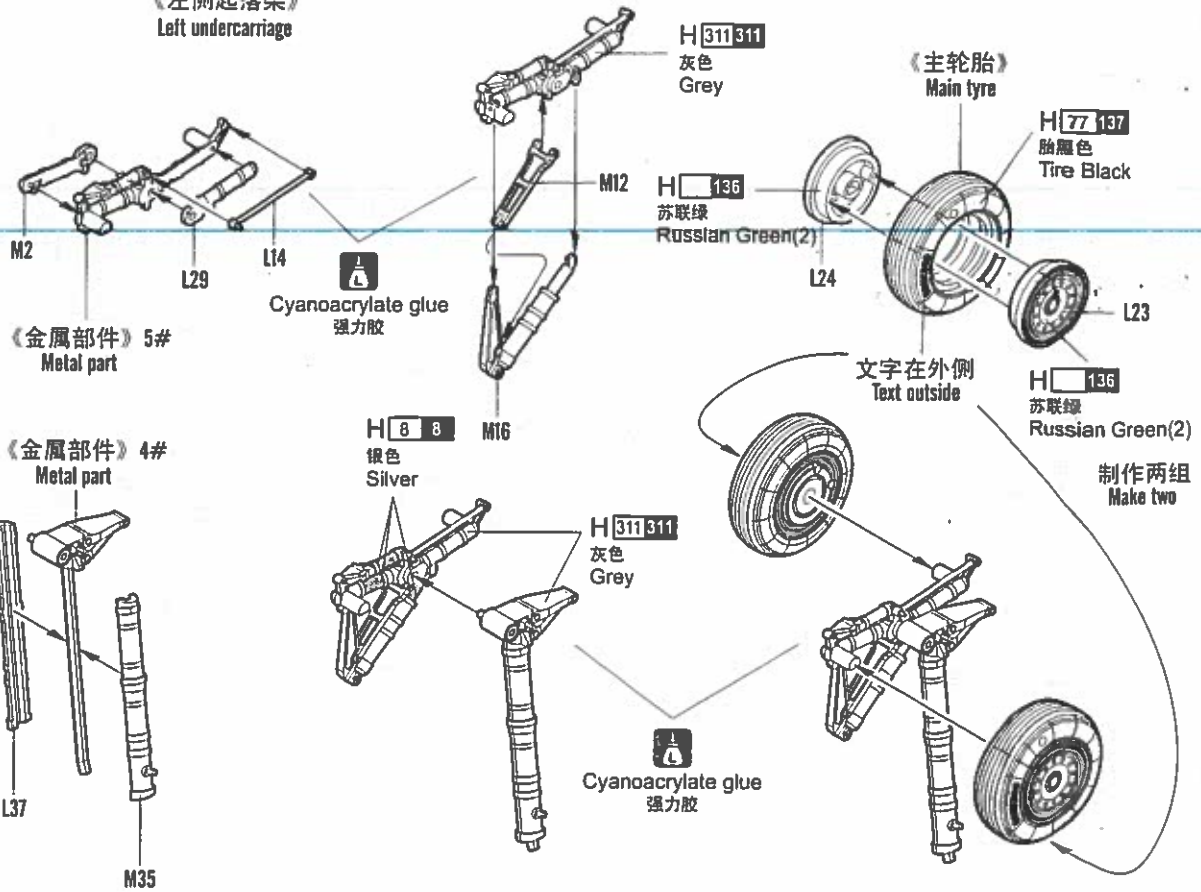

16  
STEP 16

《右侧起落架》  
Right undercarriage

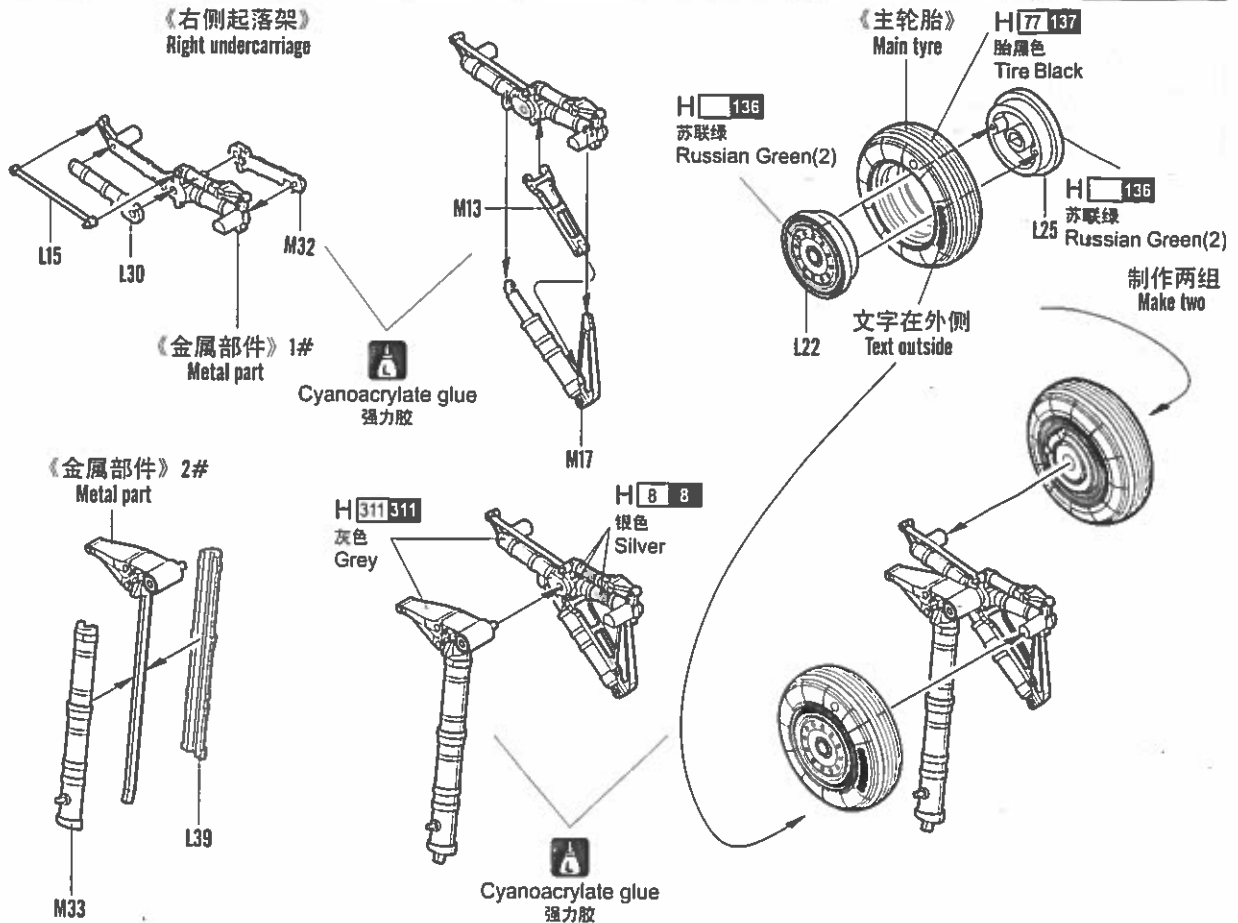



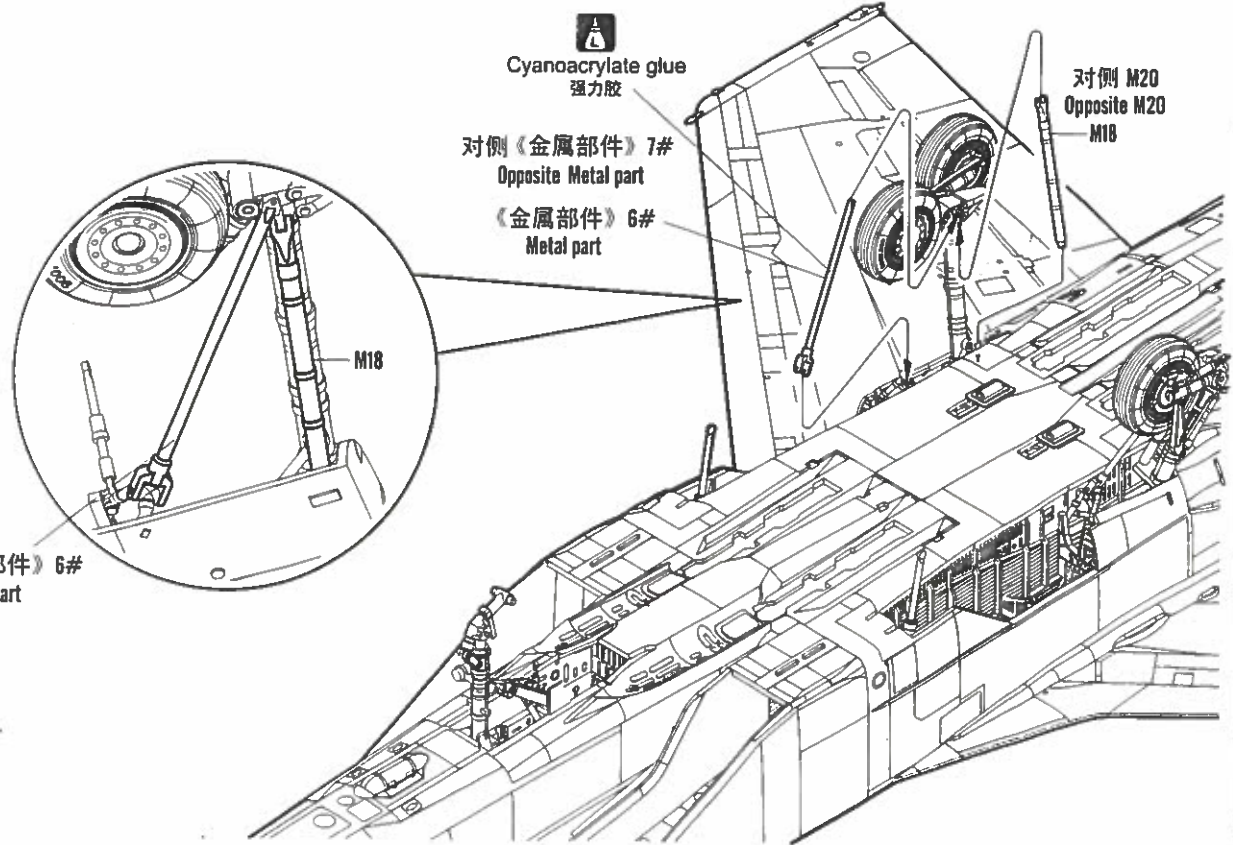
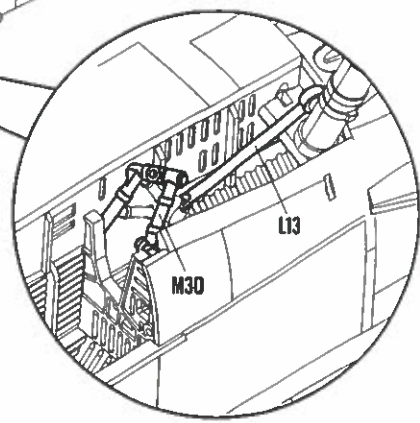
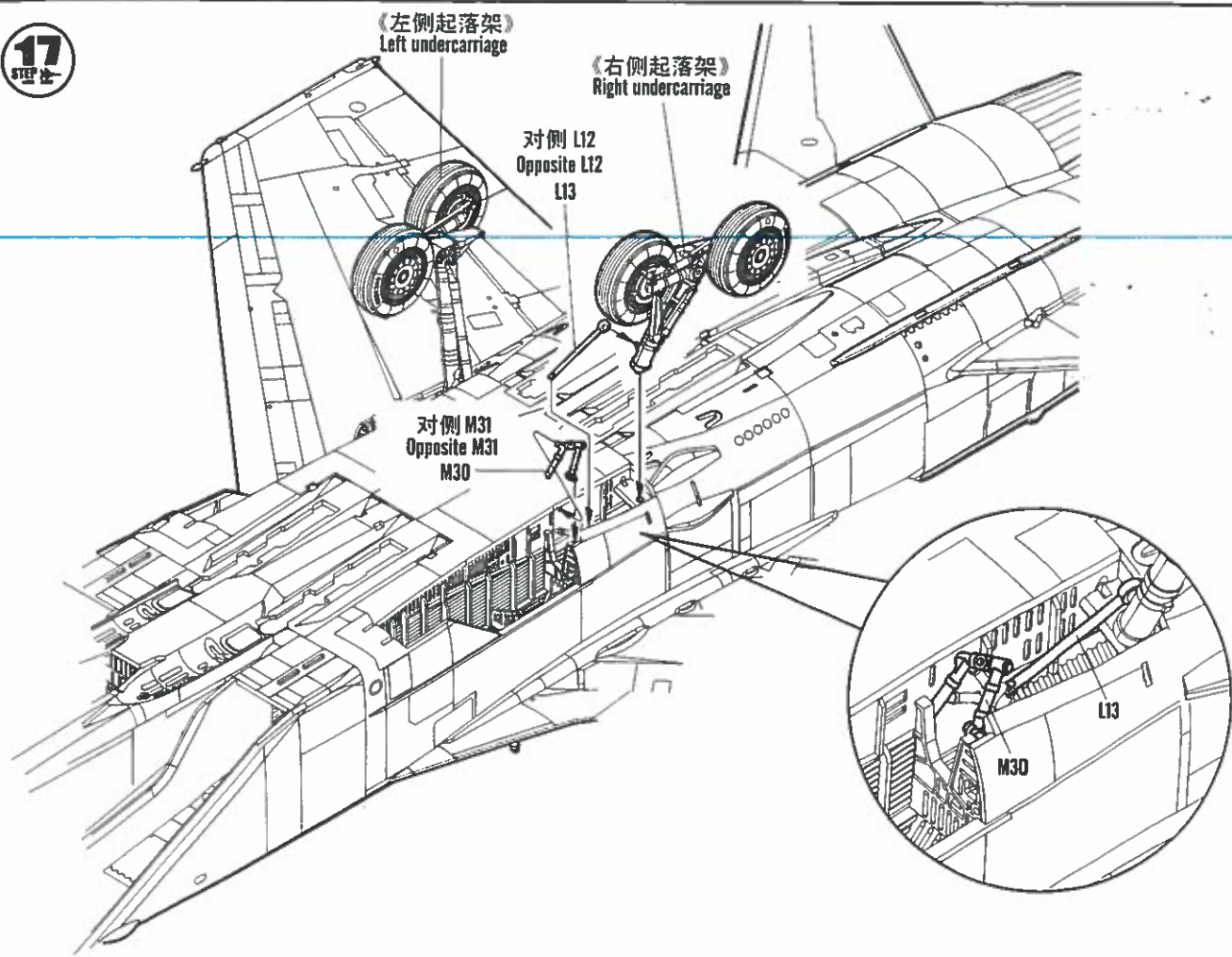

18  
STEP 18

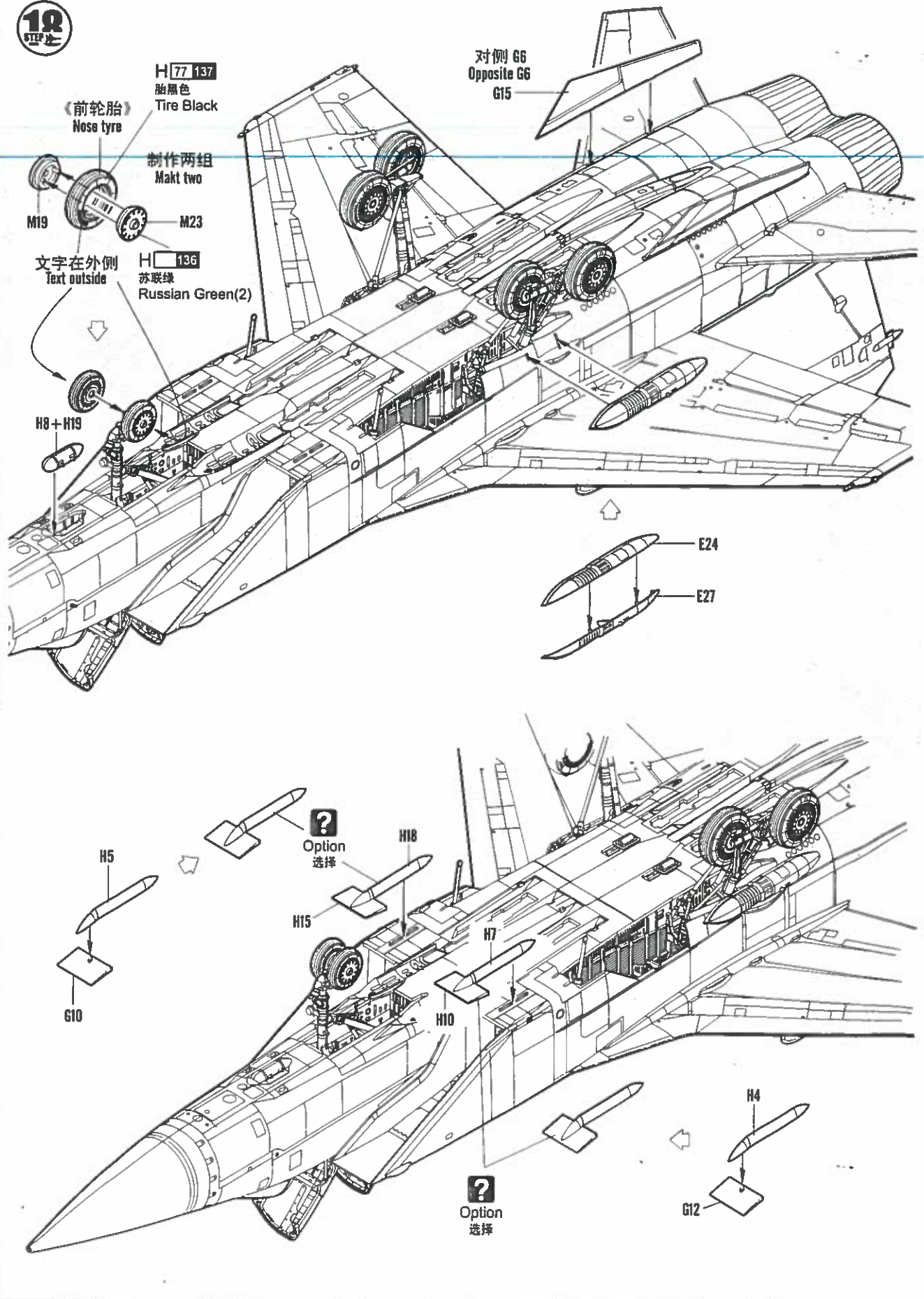

H77 137  
胎黑色  
Tire Black

《前轮胎》  
Nose tyre

制作两组  
Makt two

M19

M23

文字在外侧  
Text outside

H136  
苏联绿  
Russian Green(2)

H8 + H19

对侧 G6  
Opposite G6  
G15

E24

E27

?

Option  
选择

H5

H18

H15

H7

G10

H10

?

Option  
选择

H4

G12

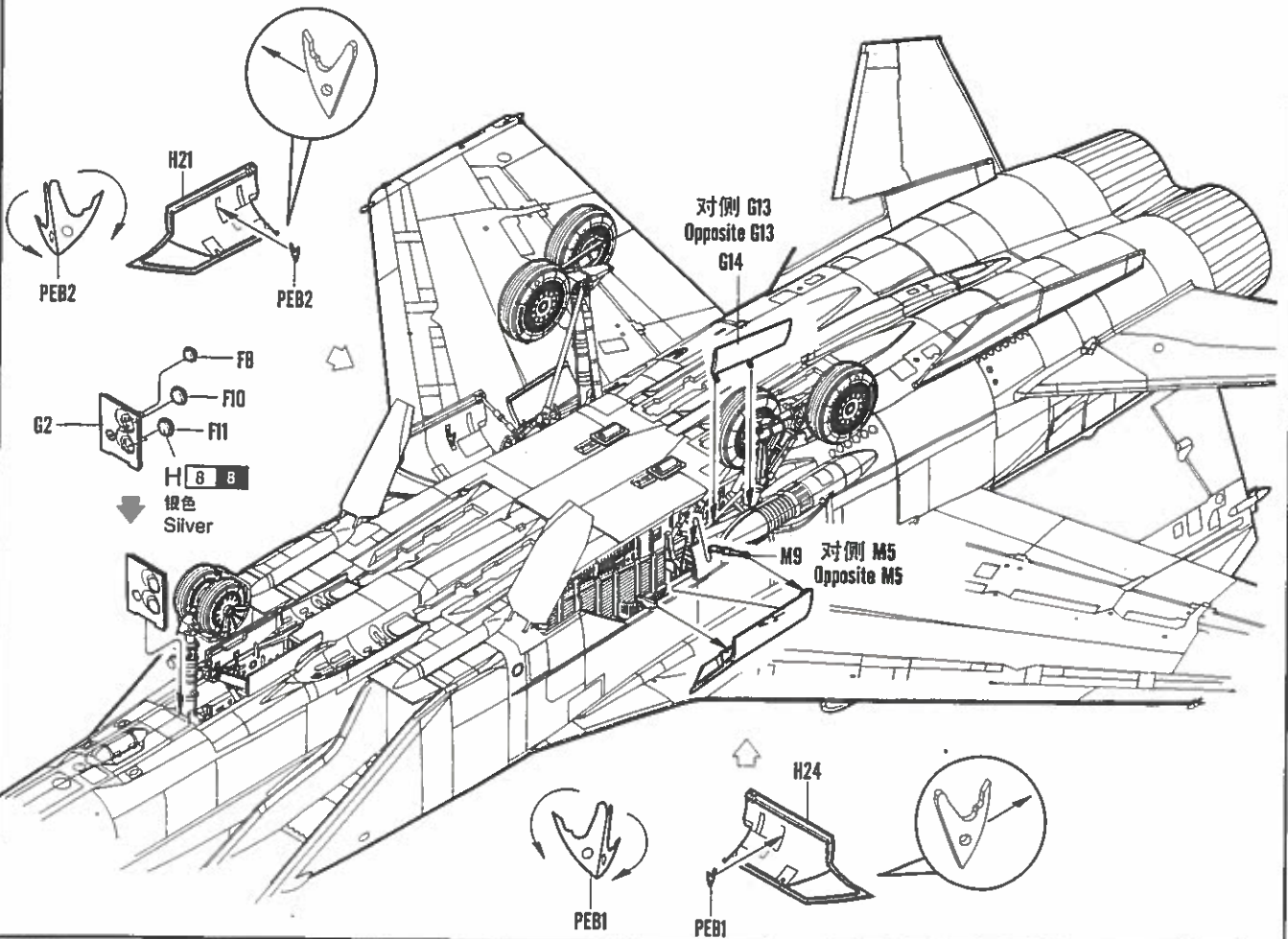
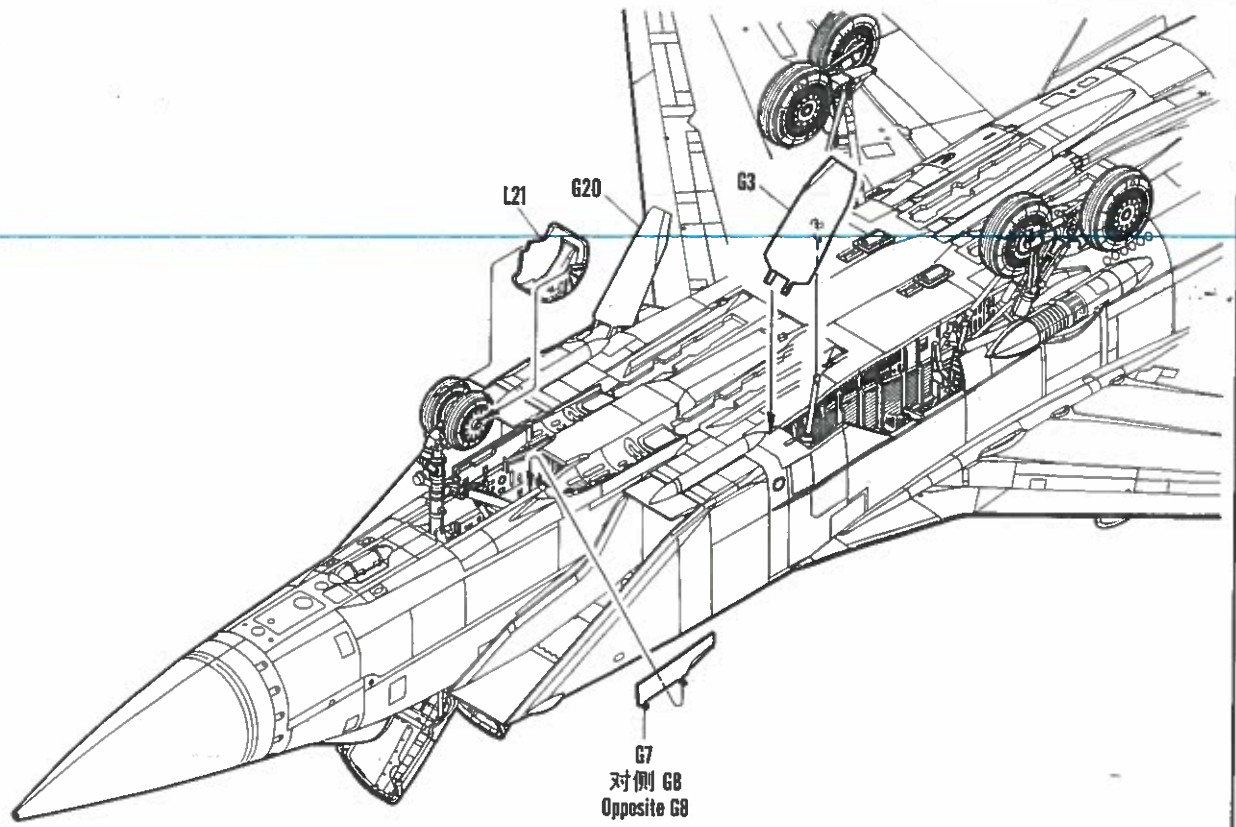

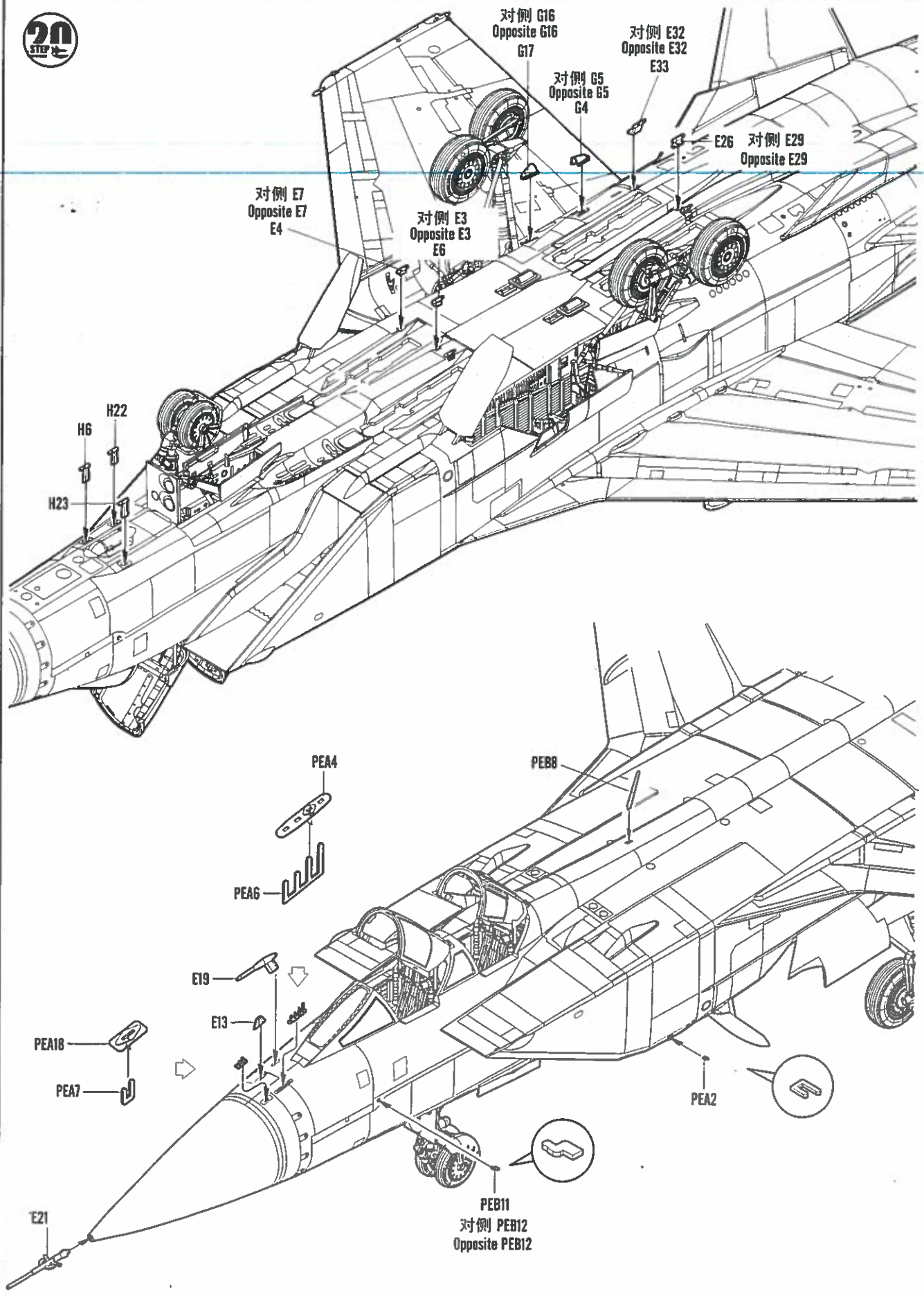

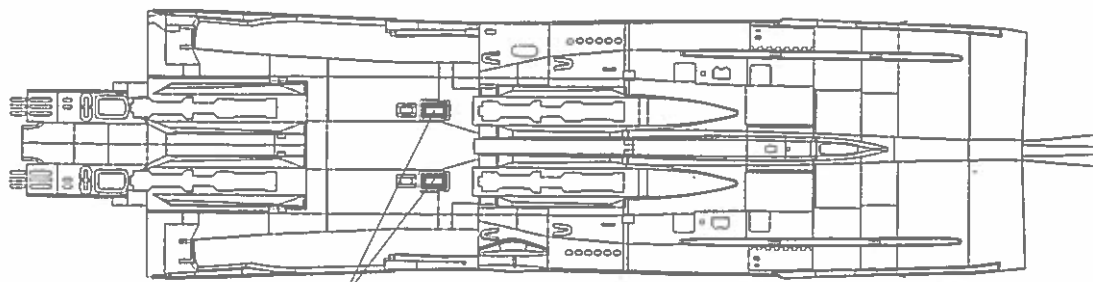
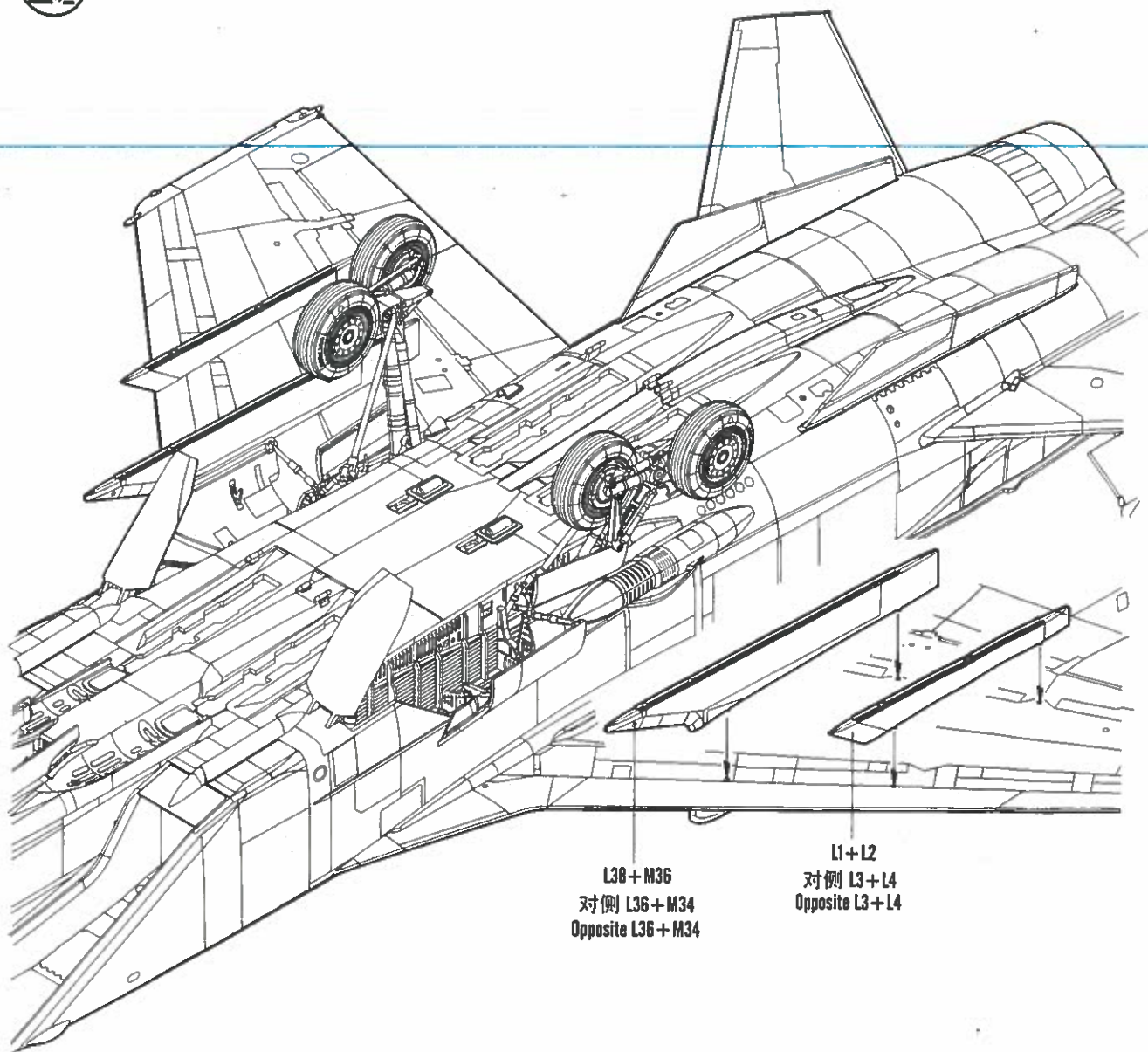

装《R-33》时切除  
Cut When install 《R-33》

22  
STEP

《R-33》

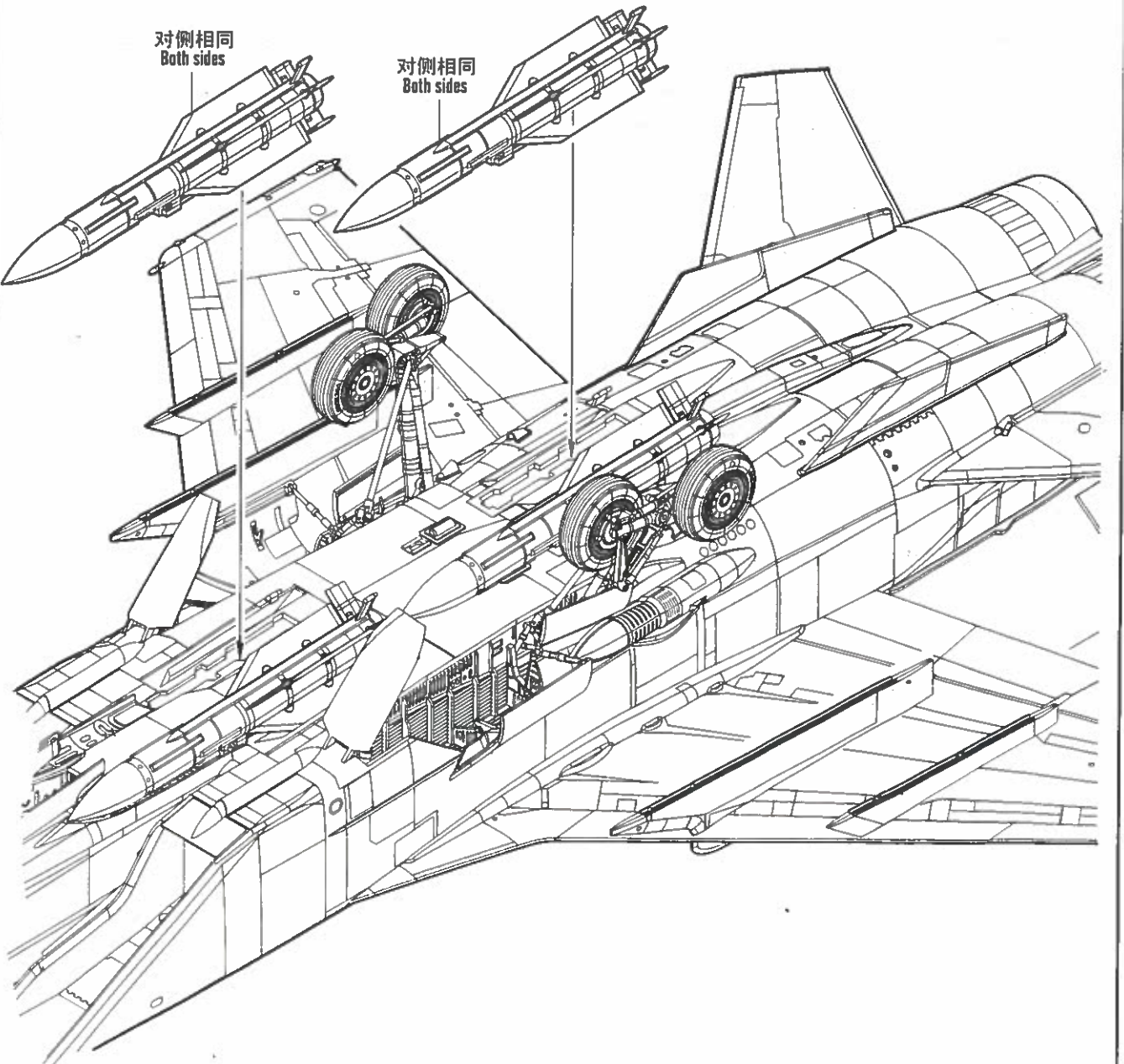
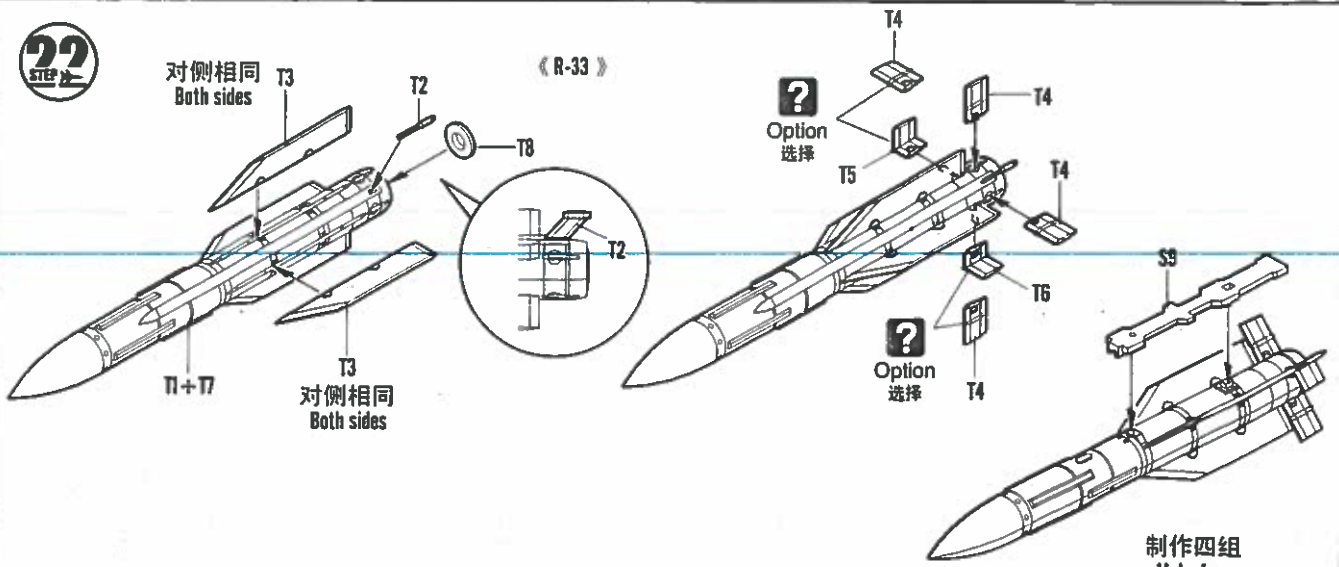

23  
STEP

《R-60》- L

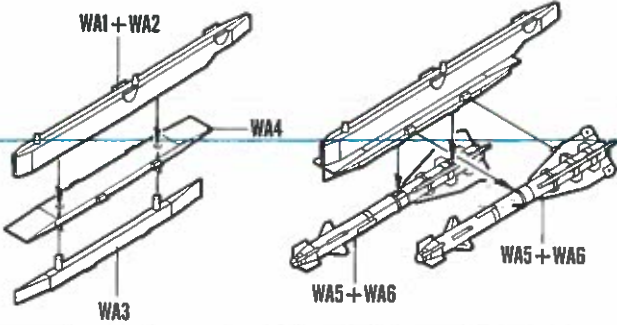

24  
STEP

《R-60》- R

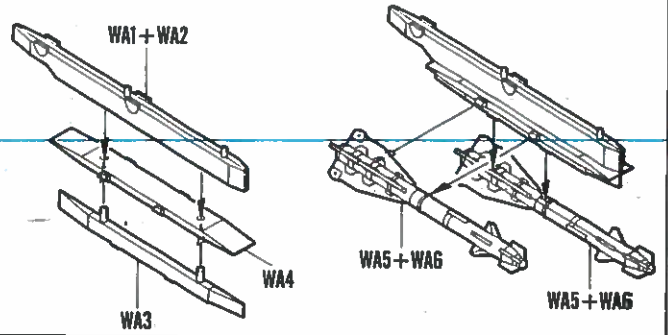

25  
STEP

《R-40T》

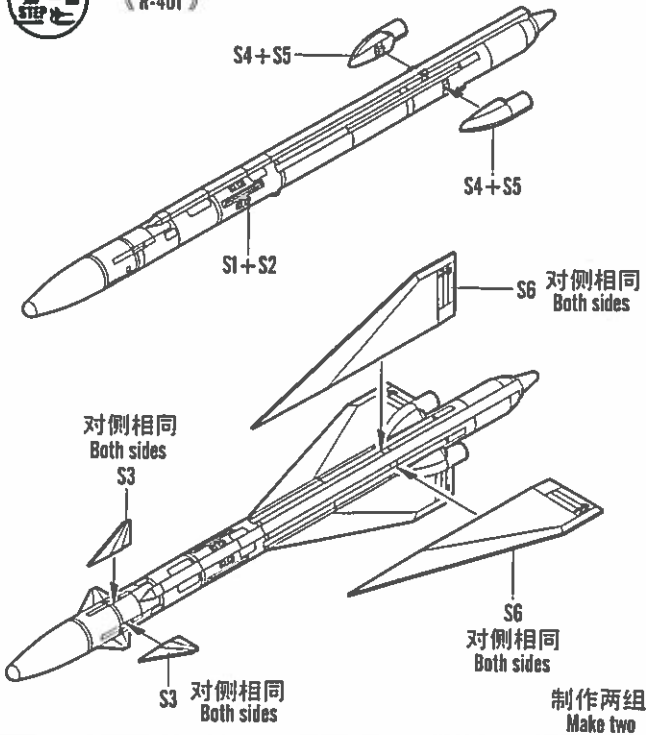

26  
STEP

《R-40R》

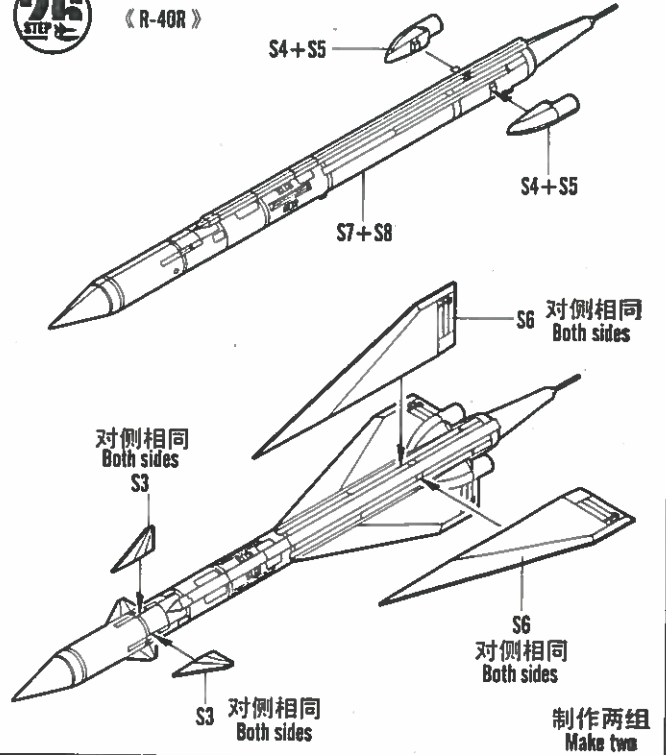

27  
STEP

《Fuel Tank》

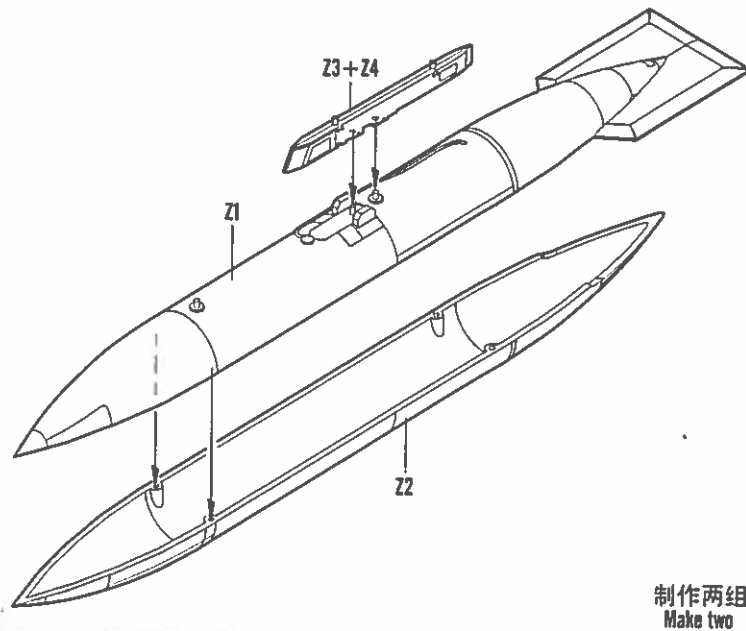

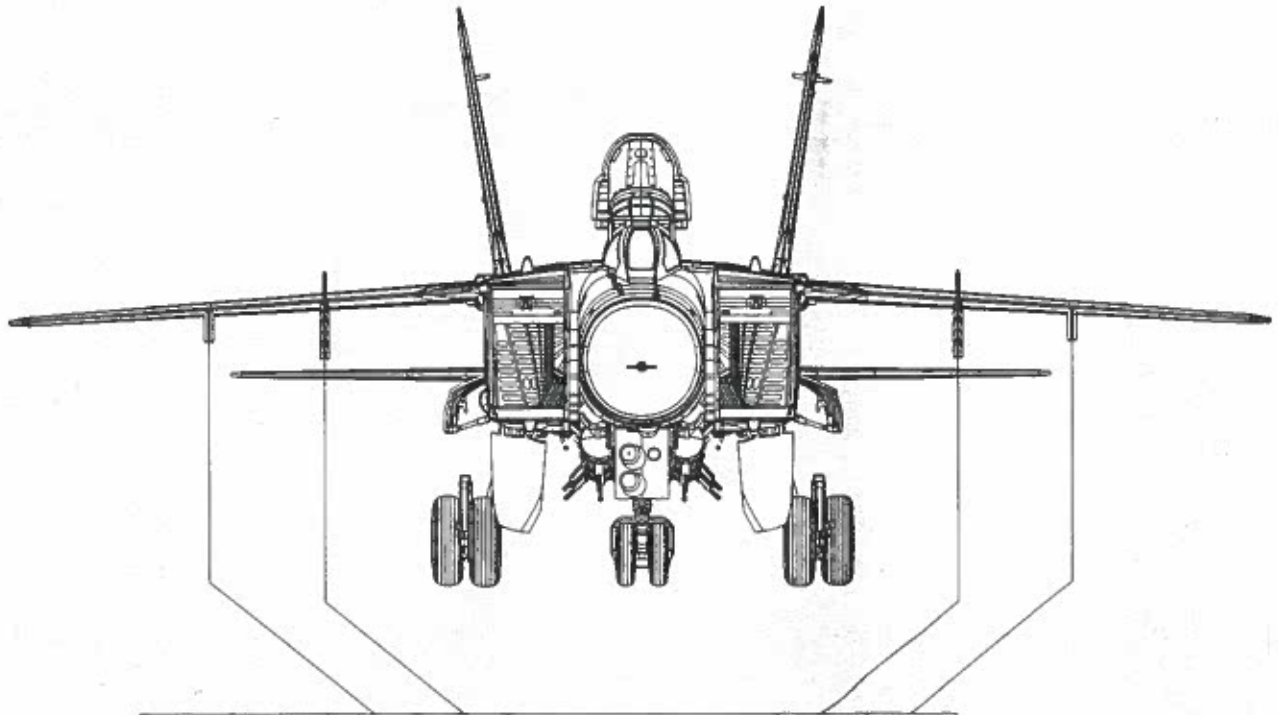

Missile	Sta.No.	1	2	3	4
R-60		●	●	●	●
R-40T			●	●	
R-40R			●	●	
Fuel Tank			●	●	





USSR/Russian, 174th Safonov GvIAP, 6th OA, Mig-31 "Boris Safonov", 08 Red(c/n.69700118127).

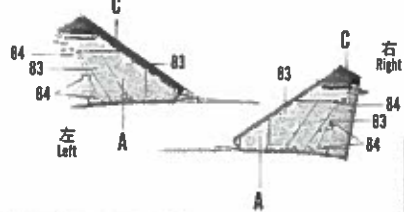
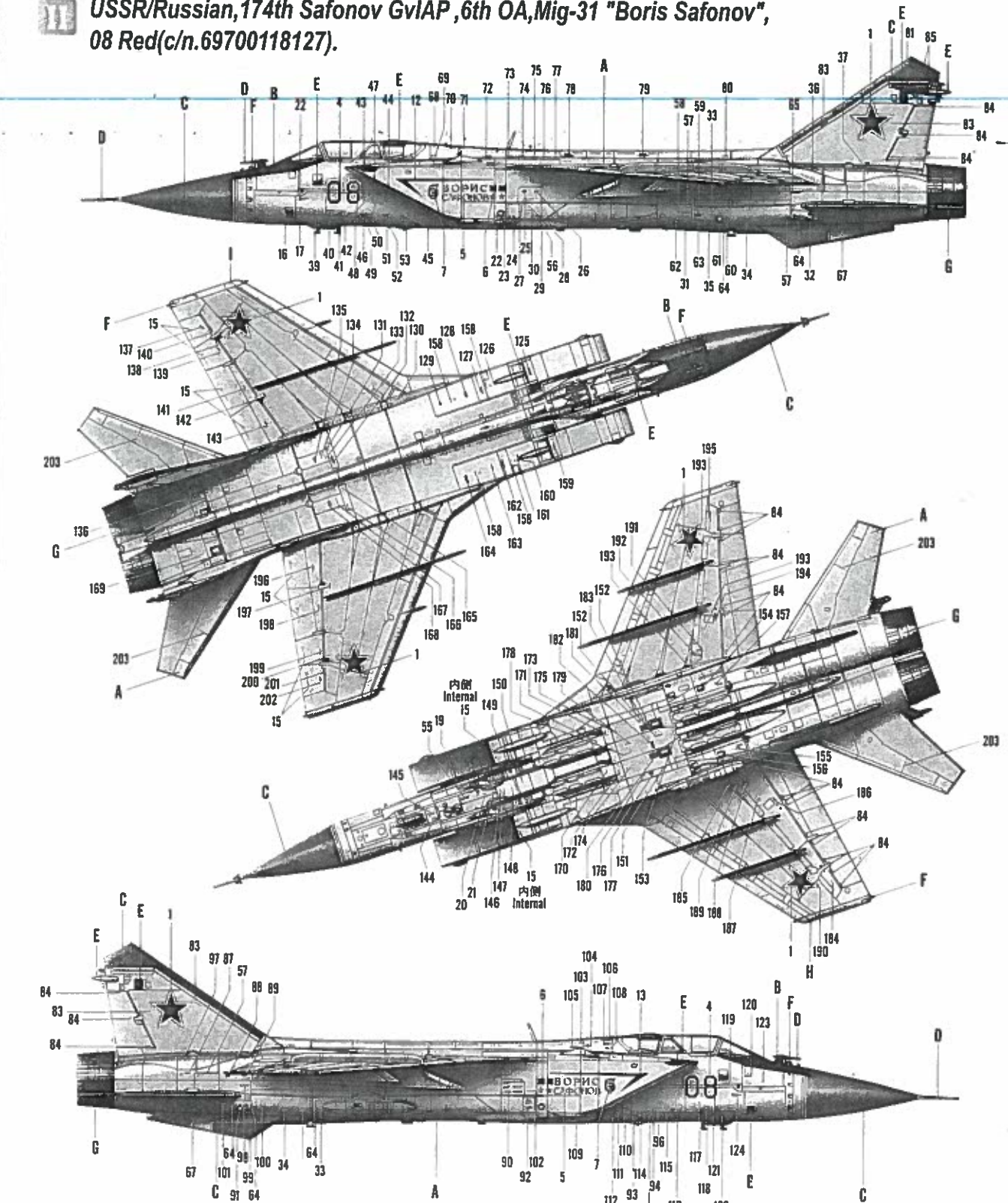

Color	Mr Hobby	Vallejo	Model Master	Tamiya	Humbrol
A 明灰白 Gray	H[81 63]	907	1731	--	146
B 哑光黑色 Flat Black	H[02 03]	950	1749	XF1	33
C 灰色 Medium Gunship Gray	H[09 003]	068	1723	XF58	125
D 银色 Silver	H[01 01]	997	1546	X11	11

Color	Mr.Hobby	Vallejo	Model Master	Tamiya	Humbrol
E 红色 Red	H[3 3]	908	1503	X7	19
F 透明橘 Clear Orange	H[02 49]	935	--	X26	--
G 烧铁色 Burnt Iron	H[78 01]	863	1795	X10	53
I 透明绿 Clear Green	H[04 03]	936	--	X25	--
I 透明红 Clear Red	H[09 47]	934	--	X27	--

NO.:81753

\* Some paints may not be available in your country. Please check your local hobby shop for substitute.

**USSR/Russian, Mig-31, 24 Blue.**

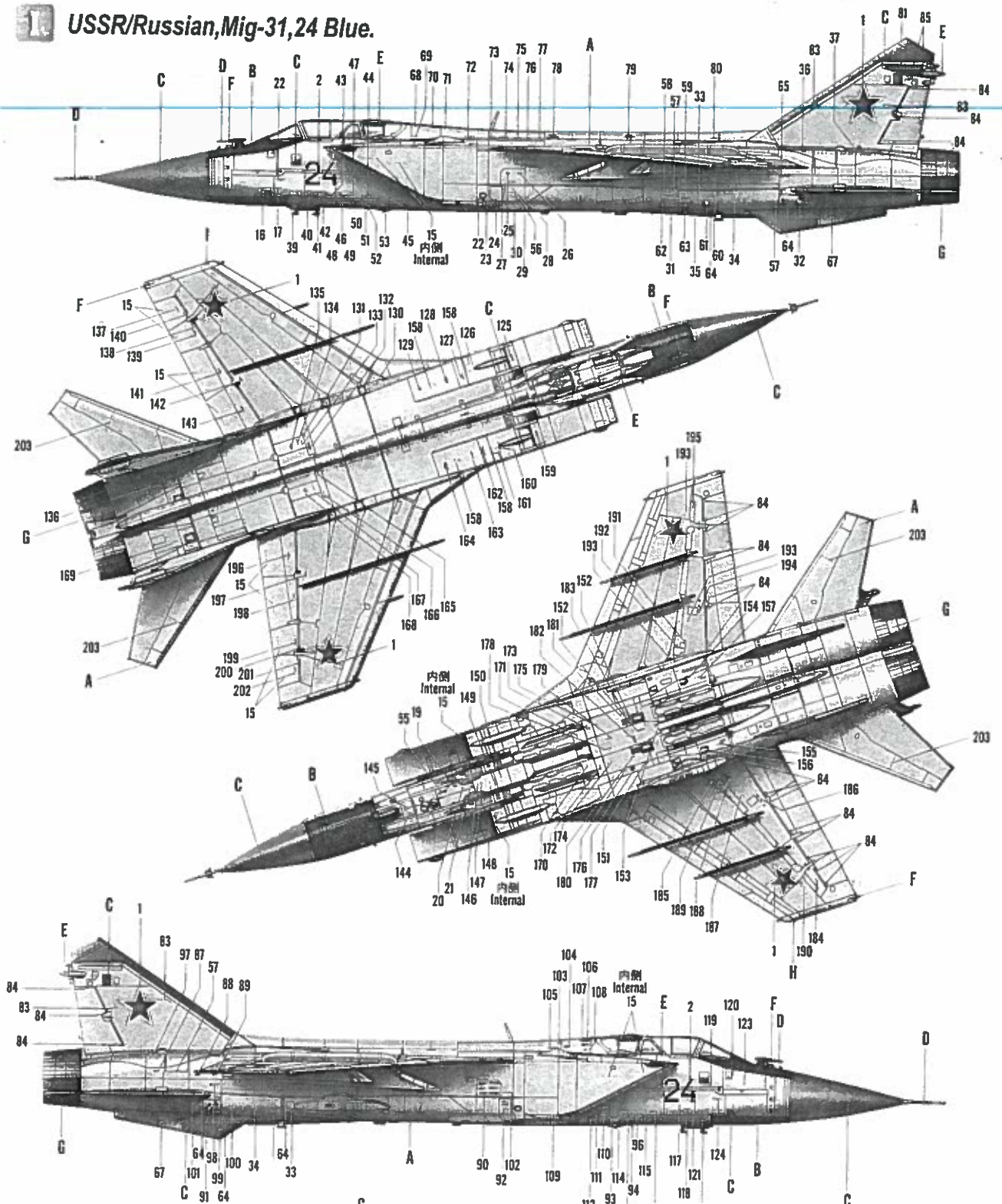

**For 61 Blue**



8a  
対側 8b  
Opposite 8b

3 対側相同 14  
Both sides

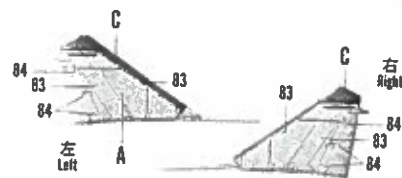

Color	Mr Hobby	Vallejo	Model Master	Tamiya	Humbrol
A 明灰白 Gray	H 61 35	907	1731	--	146
B 哑光黑色 Flat Black	H 12 33	950	1749	X71	33
C 灰色 Medium Gunship Grey	H 303 303	868	1723	XF58	125
D 银色 Silver	H 8 8	997	1546	X11	11
E 红色 Red	H 3 3	908	1503	X7	19
F 透明橘 Clear Orange	H 92 49	935	--	X26	--
G 锈铁色 Rust Iron	H 76 61	863	1795	X10	53
H 透明绿 Clear Green	H 94 138	936	--	X25	--
I 透明红 Clear Red	H 99 47	934	--	X27	--



R-60 x4

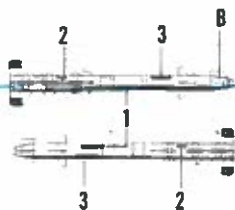

R-77 x2

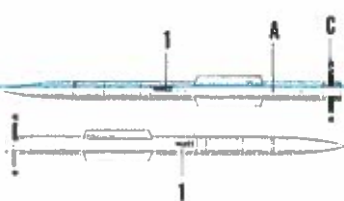

R-73E x2

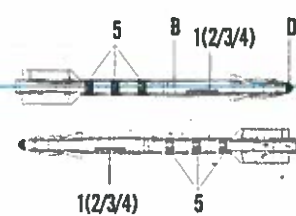

R-33 x4

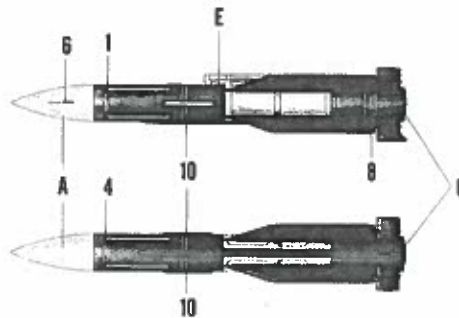
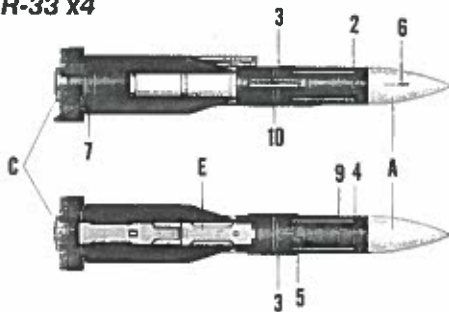

R-40R x2

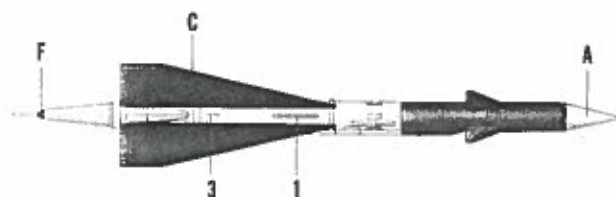
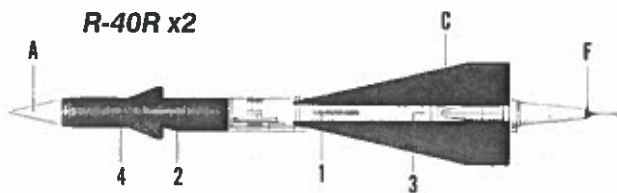

R-40T x2

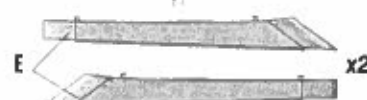
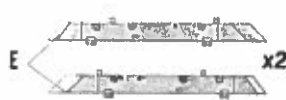
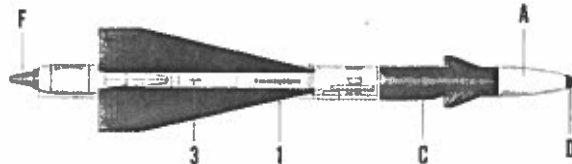
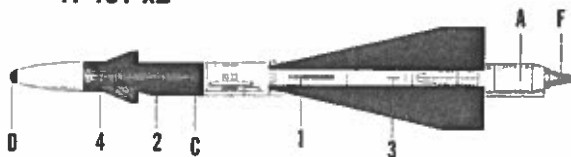

左  
Left

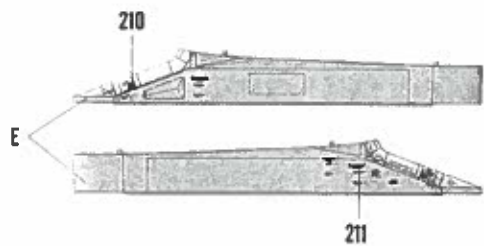

右  
Right

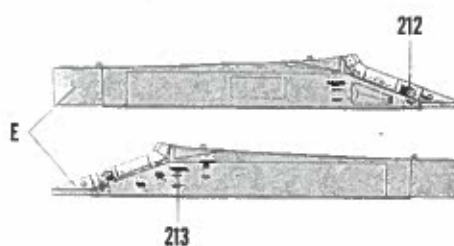

Fuel Tank x2

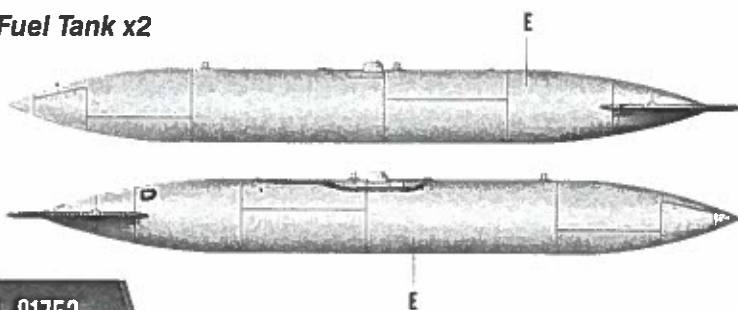

Color	Mr Hobby	Vallejo	Model Master	Tamiya	Humbrol
A 白色 White	H 1 1	842	1745	XF2	22
B 白色 White Insigata	H 118 118	991	1745	X2	22
C 黑(哑光) Flat Black	H 12 33	950	1749	XF1	33
D 烟灰色 Smoke Blue	H 95 101	--	--	--	--
E 明灰白 Gray	H 61 35	907	1731	--	146
F 红色 Red	H 3 3	908	1503	X7	19