

SCALE
1/35

U.S. ARMY
M36B1 G.M.C

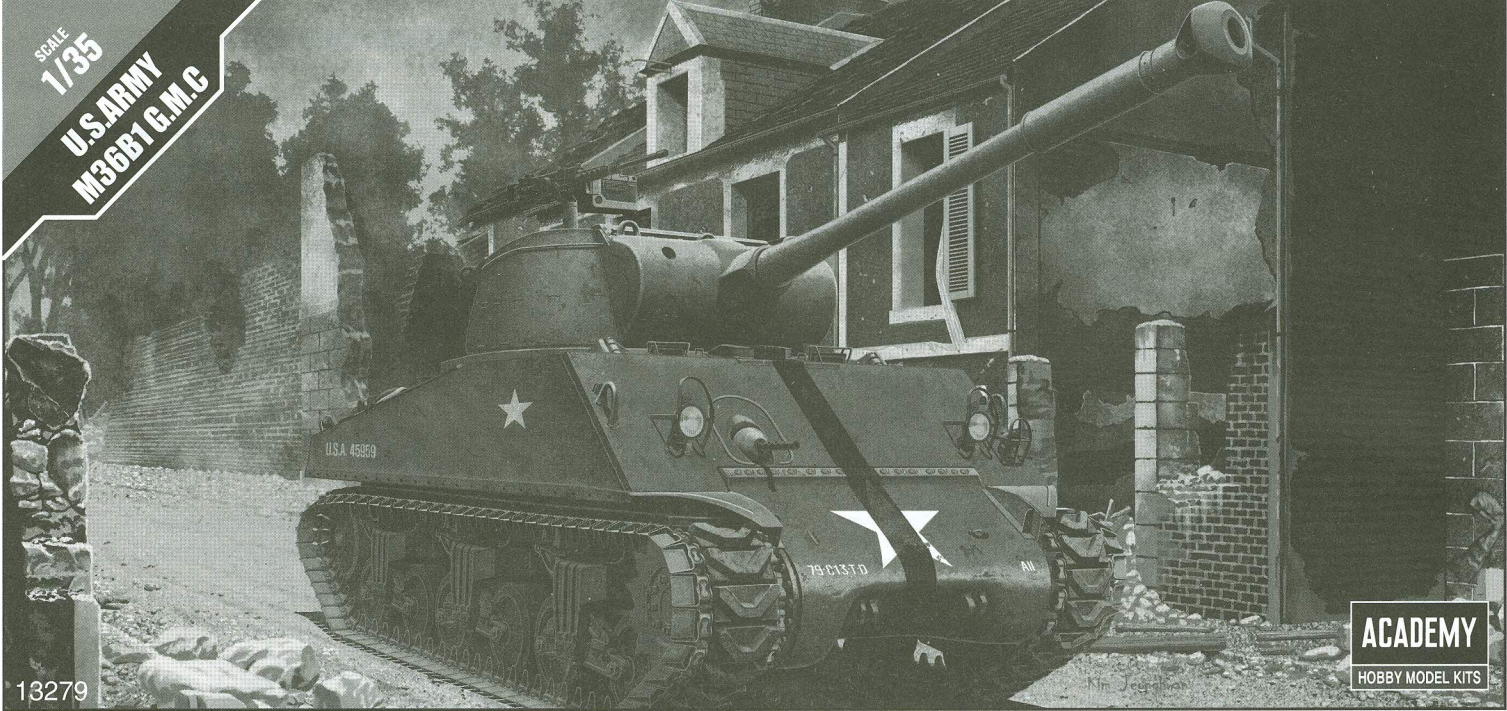

13279

ACADEMY

HOBBY MODEL KITS

Warning in Assembly of Model Kits
조립전의 주의사항

Take care not to injure yourself while using the modeling tools to cut or trim parts.
공구를 이용하여 부품을 다듬고 자를 경우, 손을 다치지 않도록 주의를 기울여 주십시오.

MAIN COLOR		5 OLIVE DRAB FS 34087 올리브 드랍											
PAINT INDEX		Humbrol		GSI Creos		Lifecolor	TESTORS / MODELMASTER		Revell		Vallejo		
		ENAMEL	Mr. COLOR	AQUEOUS HOBBY COLOR	Mr. COLOR		ENAMEL	ACRYL	ENAMEL	ACRYL	MODEL COLOR	MODEL AIR	
1	FLAT BLACK FS37038	33	33	H12	33	LC02	1749	4768	32108	36108	950	57	무광 검정색
2	SILVER FS17178	11	11	H8	8	LC74	2914	4678	32190	36190	997	63	은색
3	GUN METAL	53	53	H28	78	LC76	1405		32191	36191	863	72	건 메탈
4	WOOD BROWN	10	10	H37	43	UA085	1540		32382	36382	875		우드 브라운
5	OLIVE DRAB FS 34087	155		H52	12	UA003	1711	4728			887	43	올리브 드랍
6	KHAKI FS30277	26	26	H81	55	UA019	1704	4711	32189	36189	988	23	카키
7	CLEAR RED	91321		H90	47			4630			934		투명 빨간색

Guide for Beginners
입문자를 위한 가이드

● Water-Slide Decals/ 습식 전사지(데칼) 부착방법

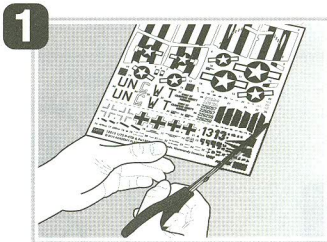

Cut desired part of decal sheet with scissors.
사용할 전사지(데칼)이 있는 부분을 가위로 오려냅니다.



Water (15 ~ 22°C)
Float the cut decal on water for 10 ~ 30 seconds.
절라넨 전사지를 물에 띄워 약 10 ~ 30초 동안 불립니다.

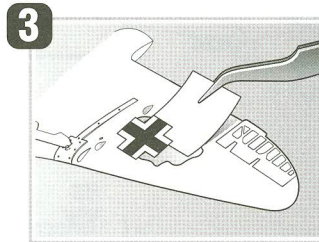

Take out the decal sheet from water and paste it to the designated area with precision tweezers.
물에서 꺼낸 전사지를 부착 부위에 정밀 핀셋을 사용해 부착합니다.

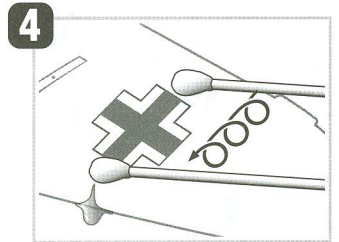

Remove water or air on the surface of decal sheet with soft tower, tissue or cotton swab.
남은 물기 및 기포는 면봉, 티슈, 부드러운 수건을 이용하여 제거합니다.

● Applying Photo Etched Parts/ 에칭 부품 적용방법

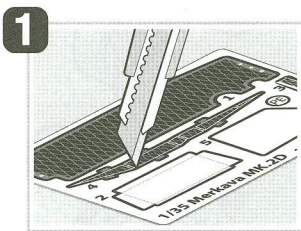

Cut off Photo Etched parts using a utility knife carefully.
사용하려는 에칭 파트를 커터칼로 조심스럽게 잘라냅니다.

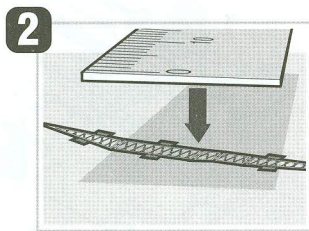

Place a flat object like a ruler on the Etched parts.
접지 않으려는 부분 위에 자와 같이 평편하며 굴곡이 없는 물체를 올려 흔들리지 않게 눌러 줍니다.

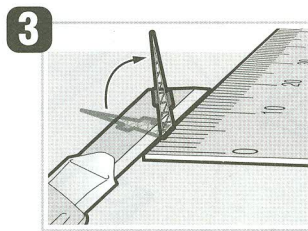

Place the knife under to bend. And carefully lift the side of the knife to fold the etched parts.
구부리려는 부분 아래에 커터칼을 놓고 커터칼의 뒷쪽을 조심스럽게 들어올려 에칭을 접습니다.

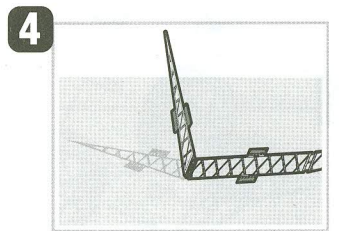

Desired position is folded neatly without damaging other places.
다른 부분의 손상없이, 원하는 부분의 에칭만을 깔끔하게 접을 수 있다.

Icon for photo etched parts
포토 에칭 부품 아이콘

PE Photo Etched Part.
포토 에칭 부품입니다.

Bend
에칭을 접으십시오.

Use instant glue
순간접착제를 사용하십시오.



CAUTION!

-주의-

<READ THIS BEFORE YOU BEGIN>
 <ALLGEMEINE HINWEISE>
 <LISEZ CE QUI SUIT AVANT DE COMMENCER LE MONTAGE>
 <組み立てる前に>
 <조립하기 전에 먼저 읽어 주십시오>

<LISEZ CE QUI SUIT AVANT DE COMMENCER LE MONTAGE>

- Etudier les schémas d'assemblage. - Contrôler que chaque pièce soit bien conforme avant de la coller à sa place.
- N'utilisez pas trop de colle pour réunir les pièces. - Ne jamais manipuler la colle ou peinture à proximité d'une flamme.
- Aérer soigneusement la pièce où vous peignez(ouvrir la fenêtre).
- Après avoir sorti les pièces du sac en plastique, déchirer le sac afin d'éviter que les enfants ne le mettent sur la tête et ne s'étouffent.

<READ THIS BEFORE YOU BEGIN>

- Study the instructions before assembling. - Check the fit of each piece before cementing into place.
- Do not use too much cement to join parts. - Never use cement or paint near open flame.
- Open a window or make area well ventilated when cement or paint is in use.
- Tear up and throw away the empty plastic bags to avoid danger of suffocation for little children.

<ALLGEMEINE HINWEISE>

- Die Anordnung der Bauteile ist aus den Zeichnungen der Anleitung ersichtlich.
- Die Teile vor dem Verkleben ungeleimt zusammenhalten, um ihren paßsitz zu prüfen.
- Klebstoff nicht zu dick auftragen. - Klebstoff und Farben niemals in der Nähe einer Flamme verwenden.
- Während der Bemalung mit Spritzpistole oder Pinsel für frische Luftzufuhr, z.B. öffnen des Fensters, sorgen.
- Bausatz von kleinen Kindern fernhalten. Verhüten Sie, daß Kinder irgendwelche Bauteile in den Mund nehmen oder Plastiktüten über den Kopf ziehen.

<組み立てる前に>

- 組み立てる前に説明書をお読み下さい。 - 部品をランナーから切りはずす時は模型用ニッパーとカッターを使用します。
- 接着剤を少ししなめに使うことがきれいに仕上げるコツです。 - 接着する前に部品を合わせて確かめます。
- 接着剤や塗料を使用する時はときどき窓を開けて換気に気をつけましょう。
- 組み立て後の部品やビニール袋は小さな子供の手の届かない安全な所に保管して下さい。

조립하기 전에

- 부품을 조립하기 전에 설명서를 잘 읽어본 후 조립한다.
- 접착하기 전에 부품을 맞추어 확인한 후 조립한다.
- 부품을 자를 때에는 칼이나 니퍼로 깨끗이 잘라준다.
- 접착제를 사용할 곳과 사용하지 않는 곳에 주의하고 너무 많이 바르지 않도록 한다.
- 에나멜 페인트나 접착제를 사용할 때는 창문을 열어 환기를 시키고 화기를 멀리한다.
- 사용 후 남은 부품은 어린 아이들의 손에 닿지 않도록 잘 처리한다.

점착한다. Cement parts Coller Kleben	점착하지 않는다. Do not cement Ne pas coller Nicht kleben	2 수만큼 조립한다. Repeat operation Répéter l'opération Vorgang wiederholen	DECAL 전사지를 붙인다. Add weight Lester Gewicht	무게추를 넣는다. Add weight Lester Gewicht	구멍이나 홈을 메워준다. Use filler Mastiquer Schleifen
잘라낸다. Cut away Couper Schneiden	선택한다. Optional parts Choix Auswahlmöglichkeit	반대측도 조립한다. Repeat for opposite side Répétition de la page Wiederholung für gegenüberliegende Seite	구멍을 뚫어준다. Make hole Faire un trou Öffnen	주의한다. Be careful Faire attention Hier Vorsicht	1 색칠 및 전사지 붙이기 번호 Painting scheme number Numeros de la liste de peintures Lackierschemanummer

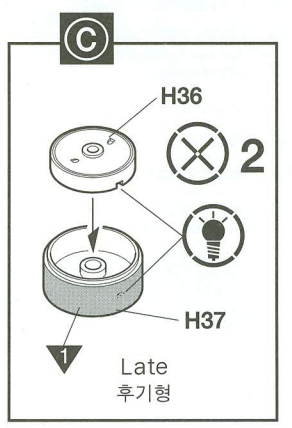
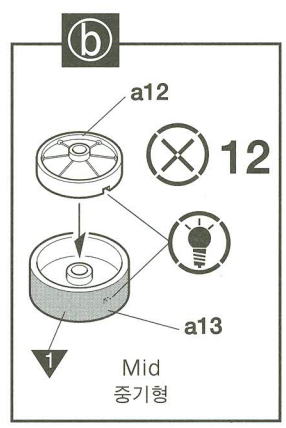
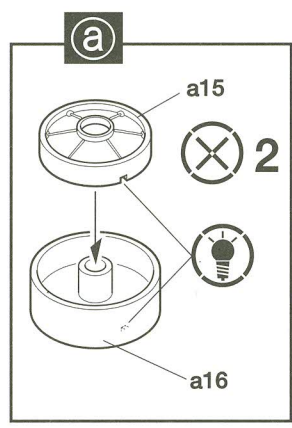
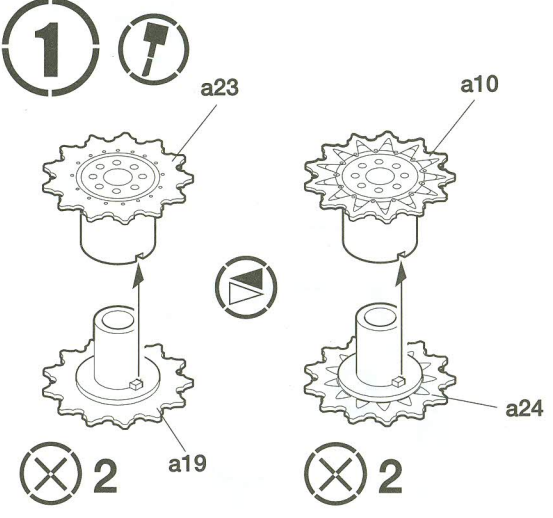

* C is optional parts.
C는 옵션 부품입니다.

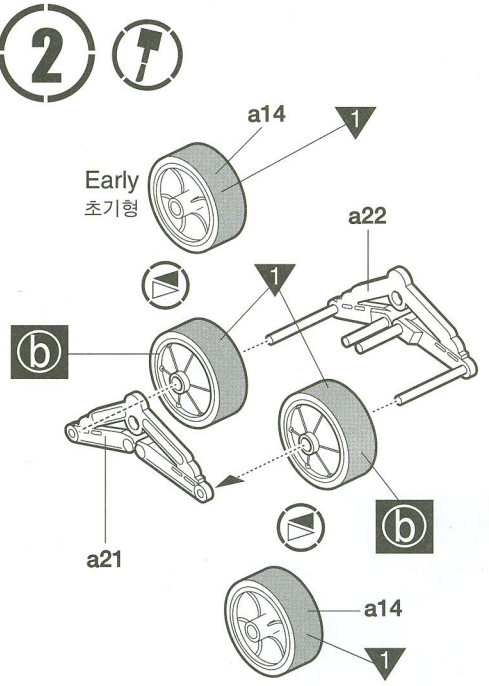

※ () is opposite number.
()는 반대측 번호입니다.

Right 우측: R12, R13
 Left 좌측: R11, R10

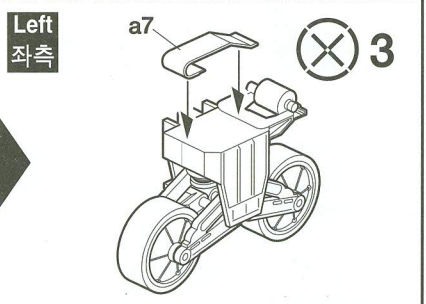
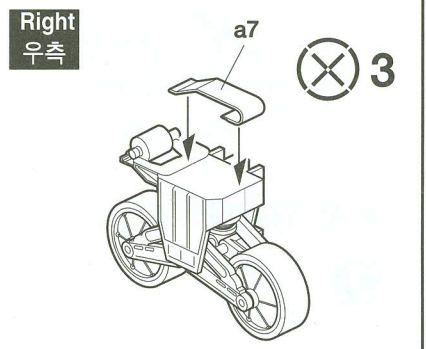
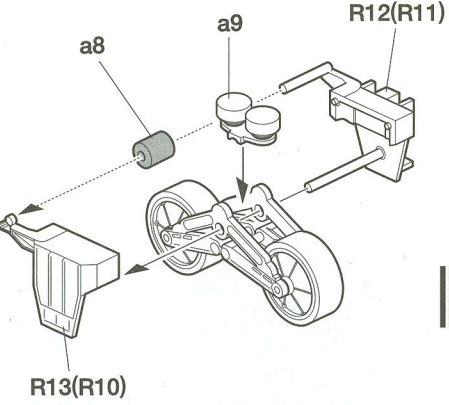

3 

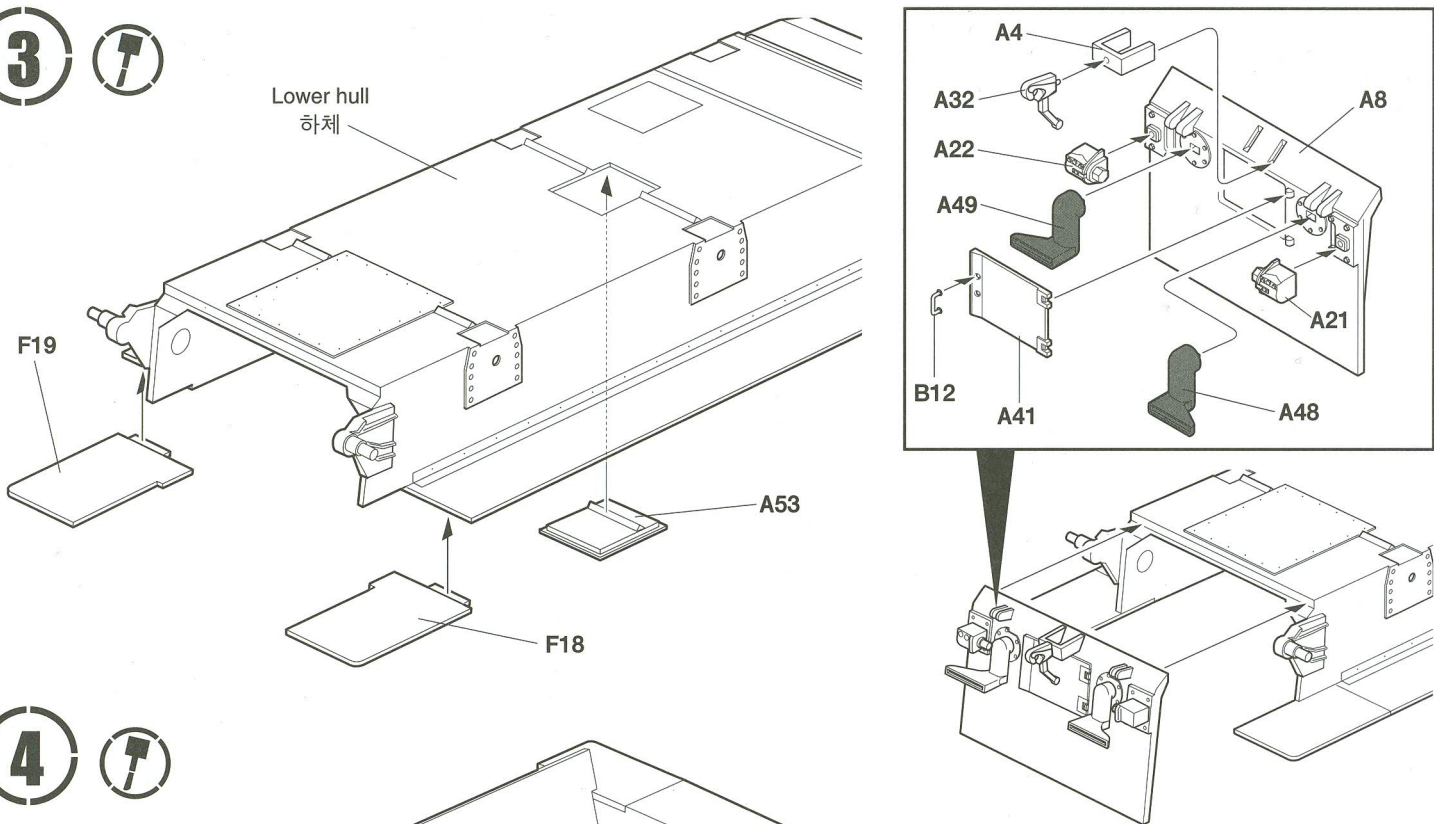

4 

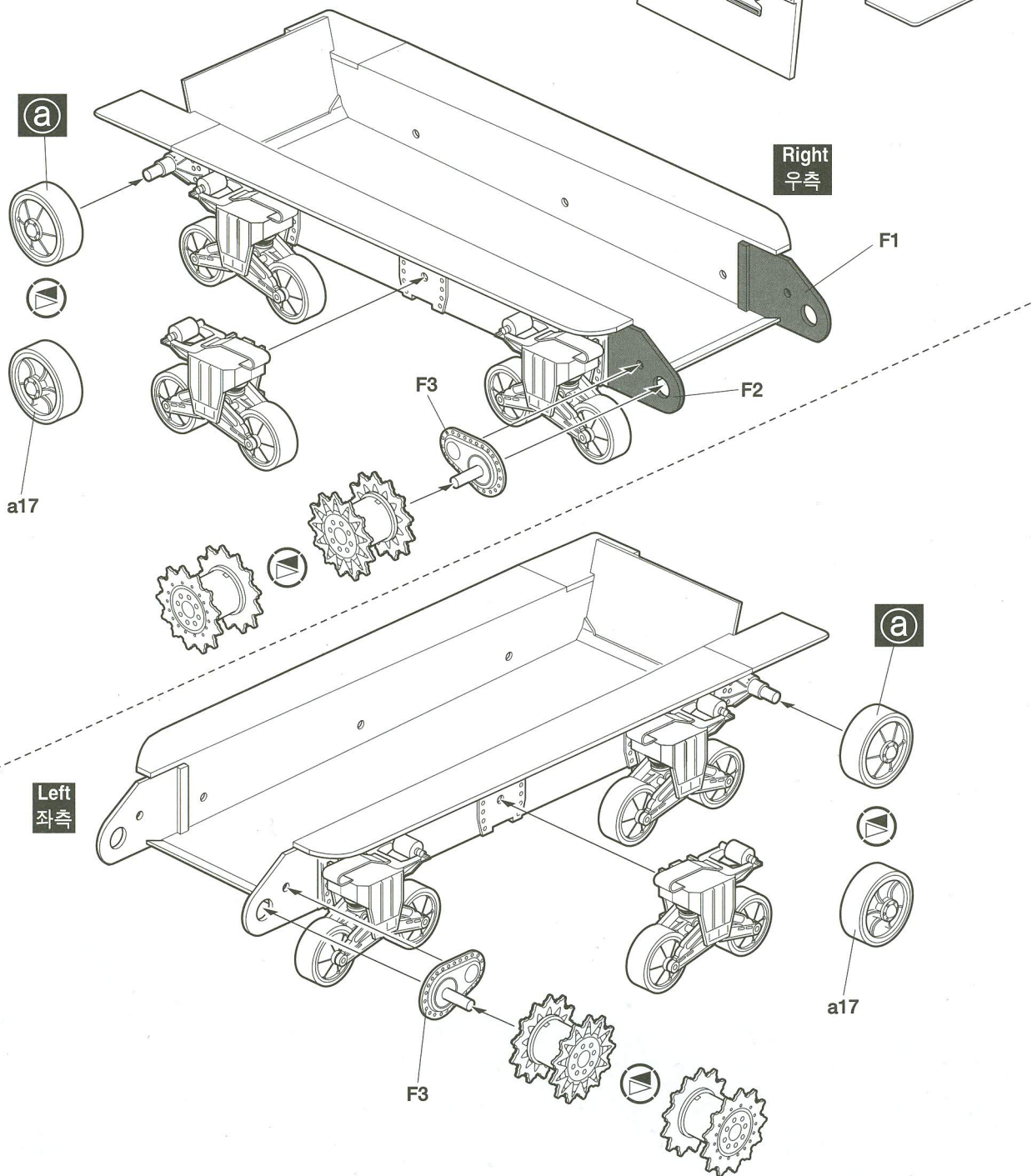

5

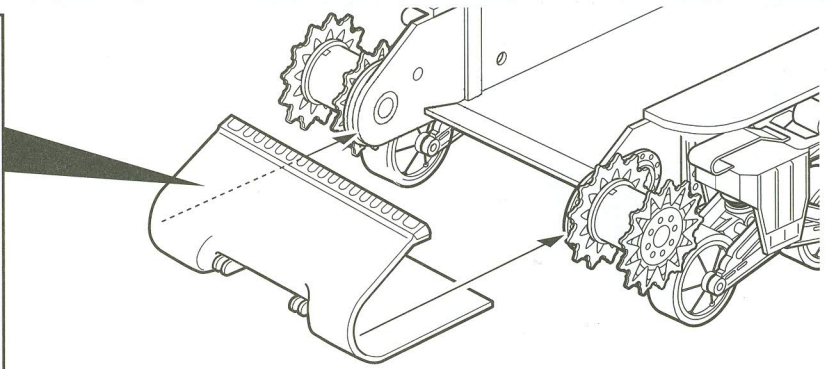
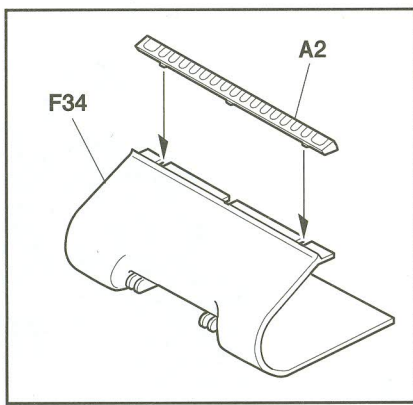

6

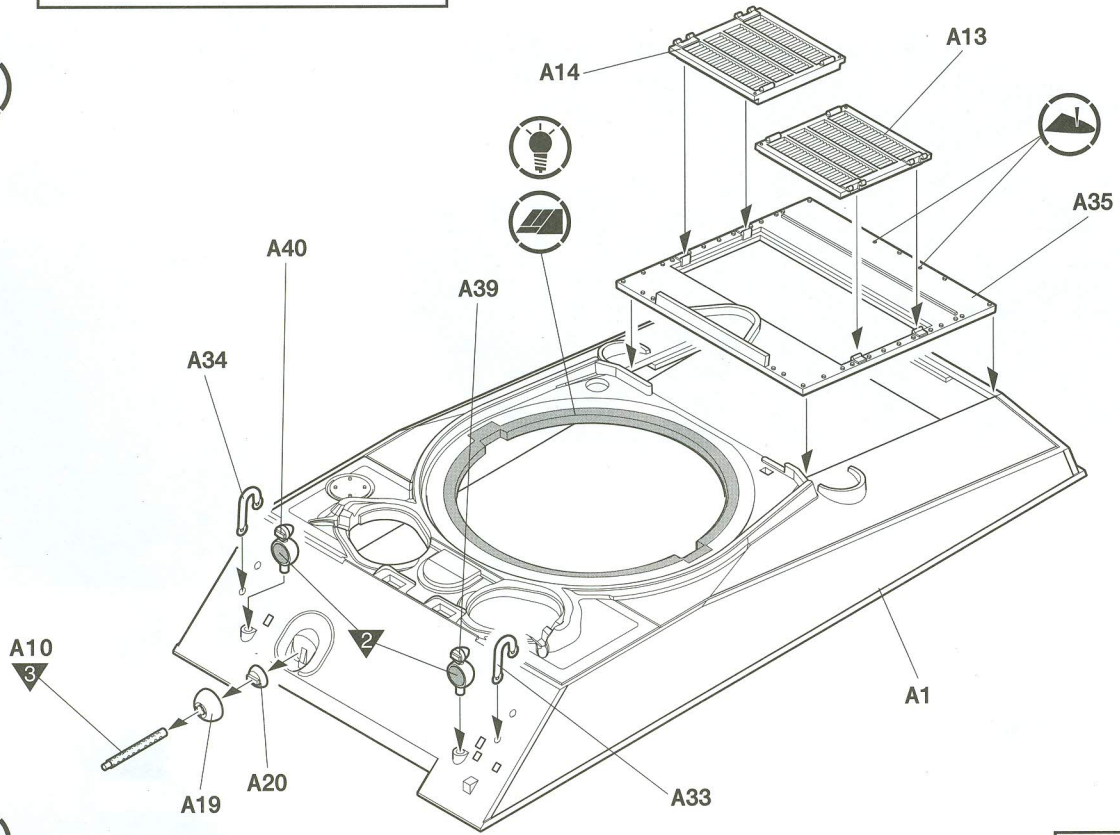

7

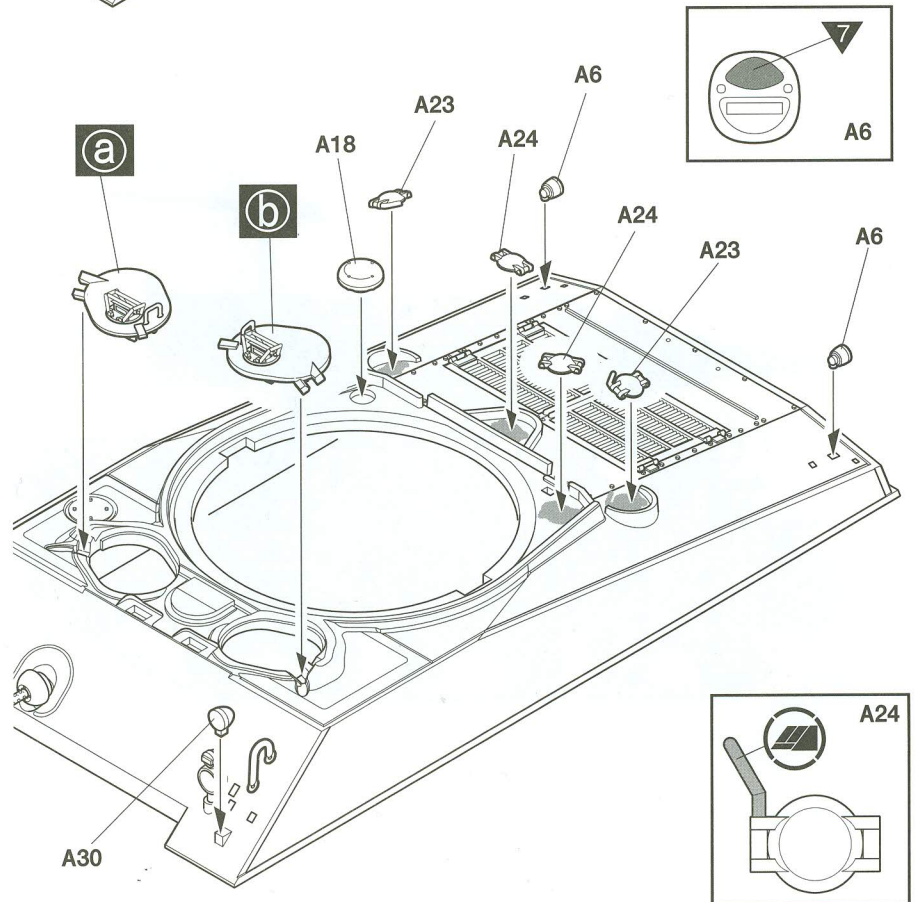
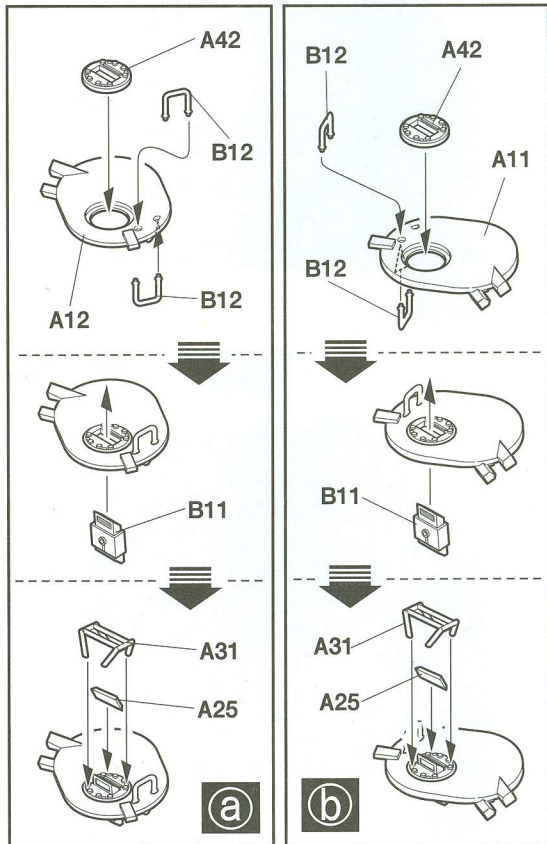

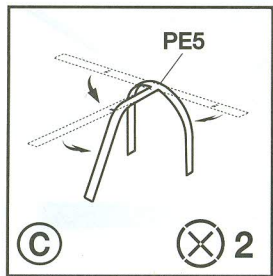
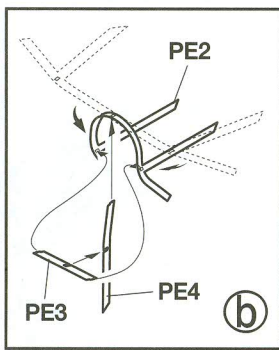
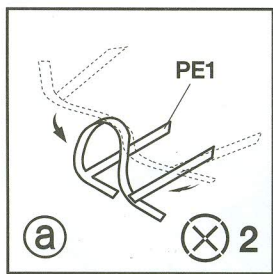

8 

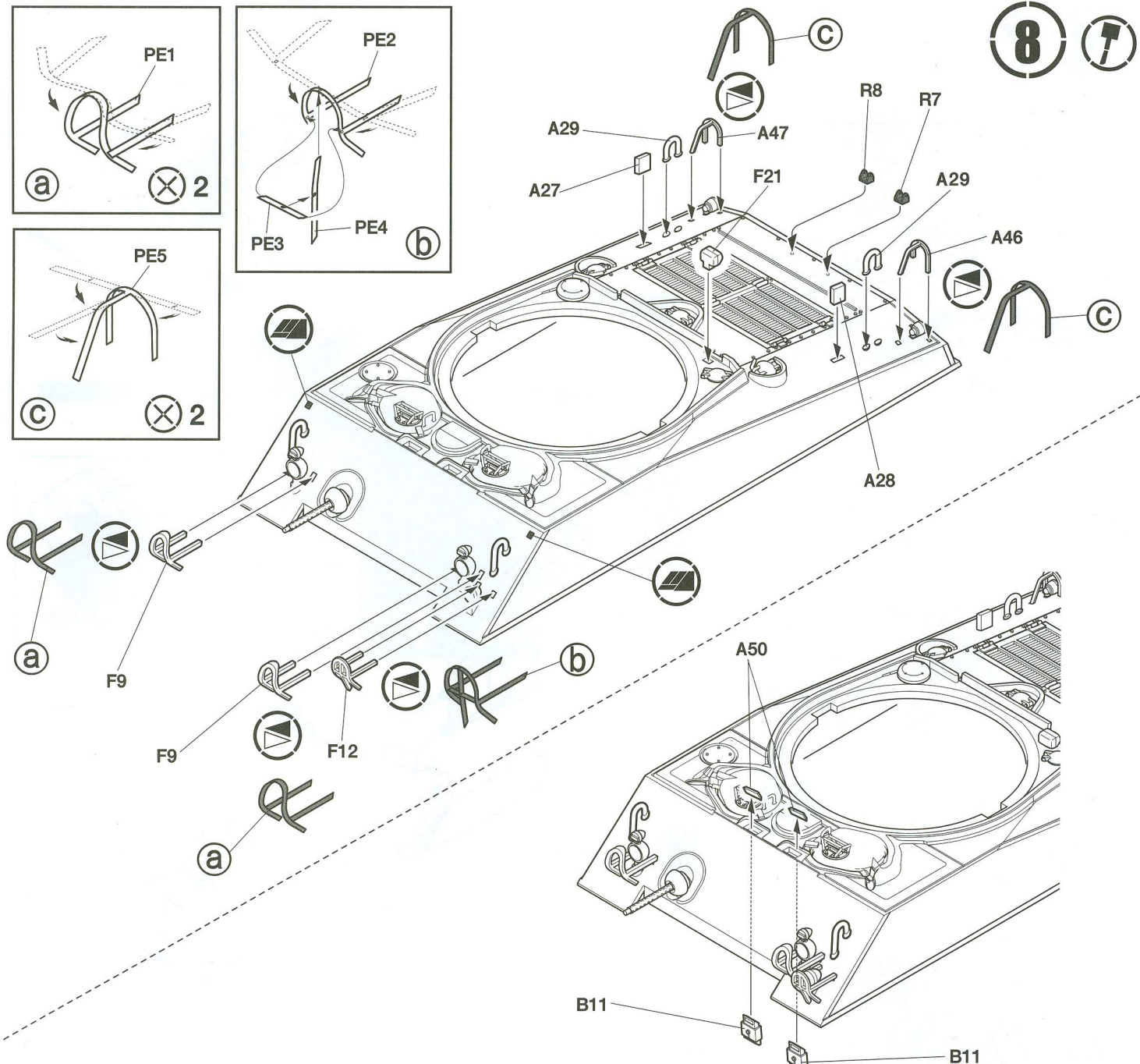

9 

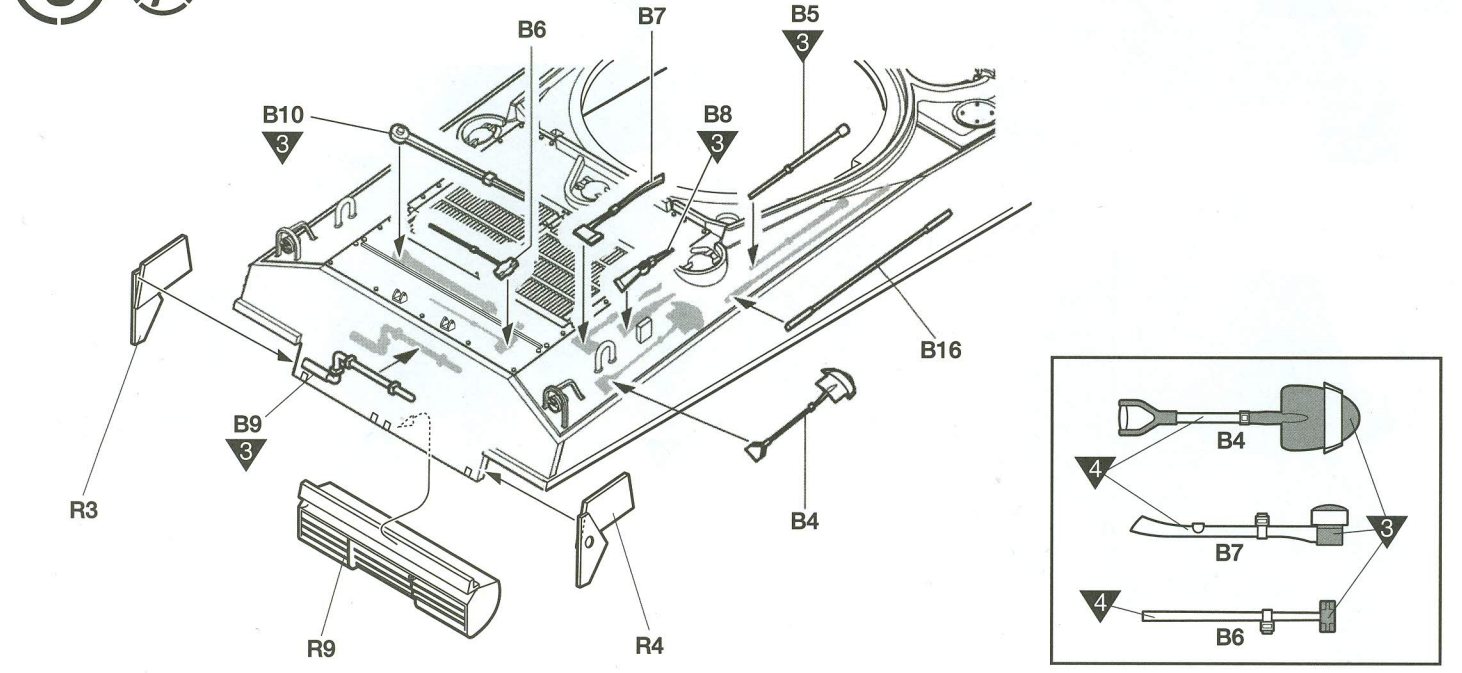

10 

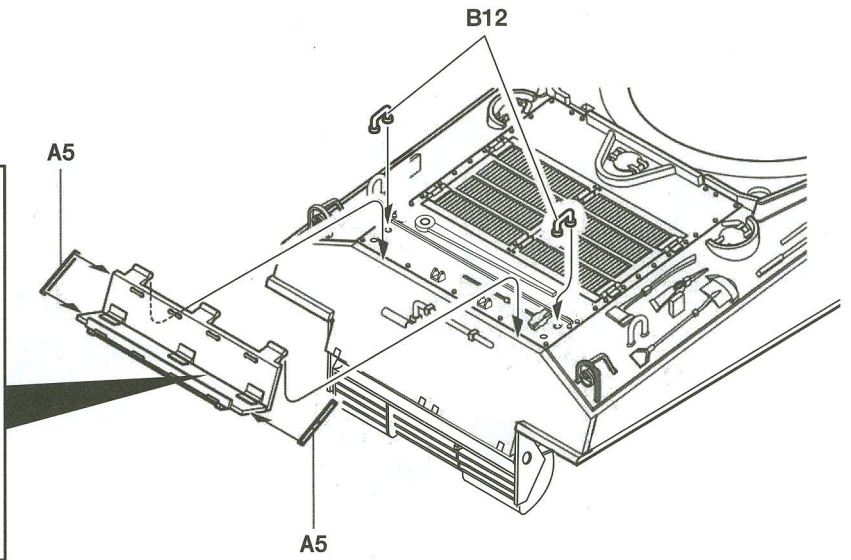
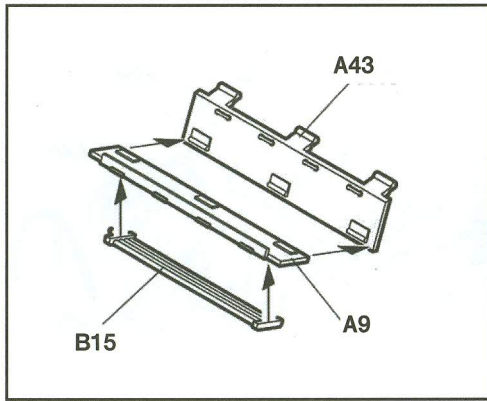

11 

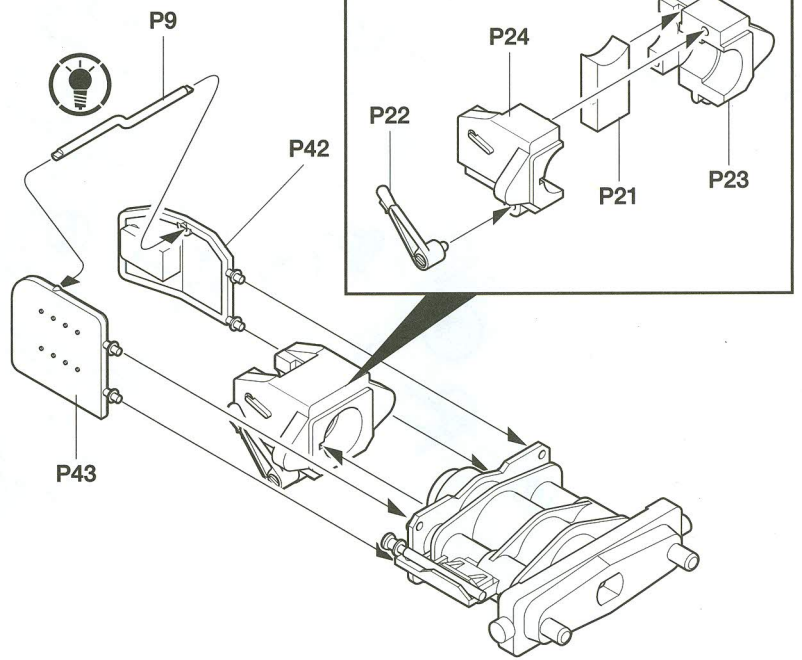
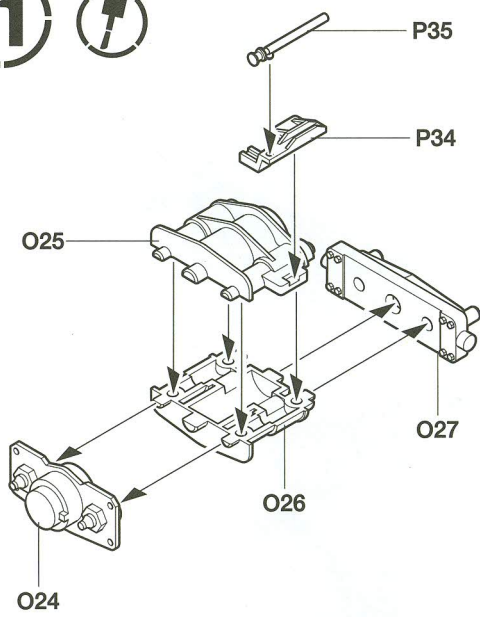

12 

Turret Interior Color
포탑내부색

5

Turret(Lower)
포탑(하)

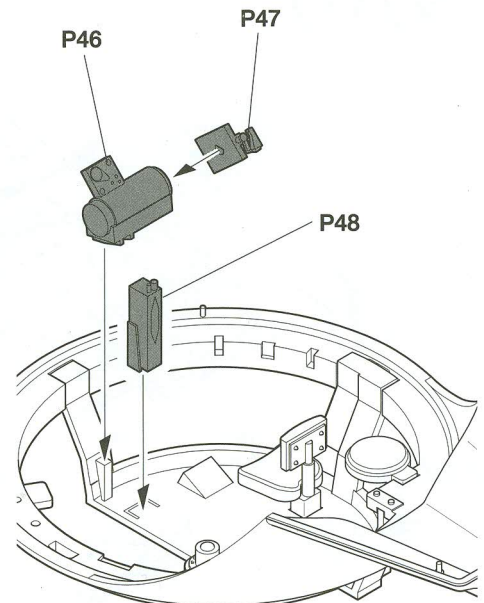
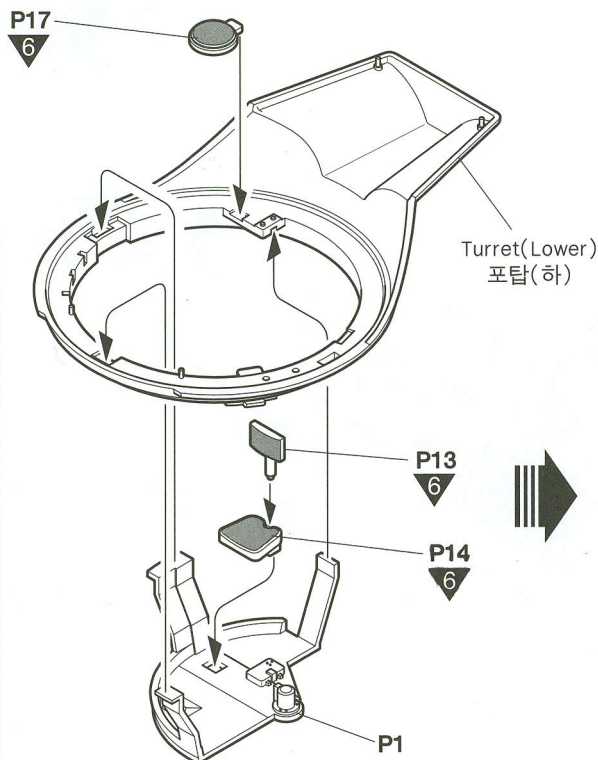
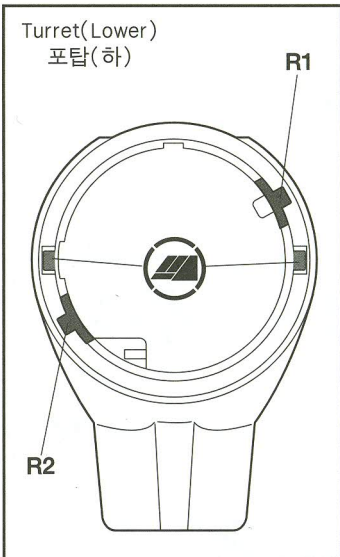

※ Refer continued manual(4page) to complete.
4페이지의 별도 설명서로 이어 집니다.

13

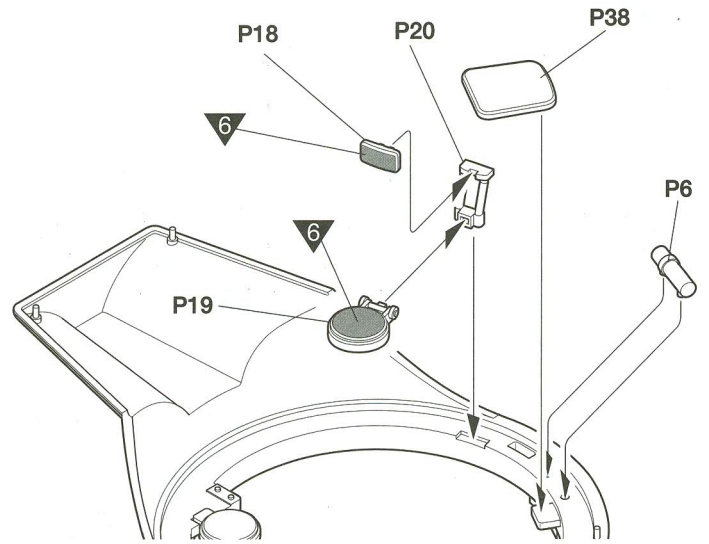
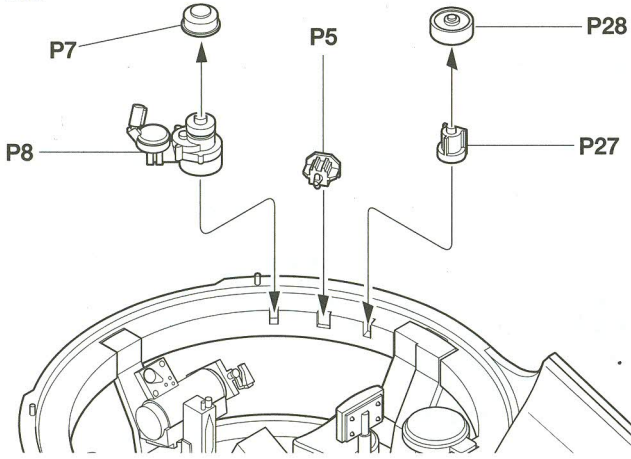

14

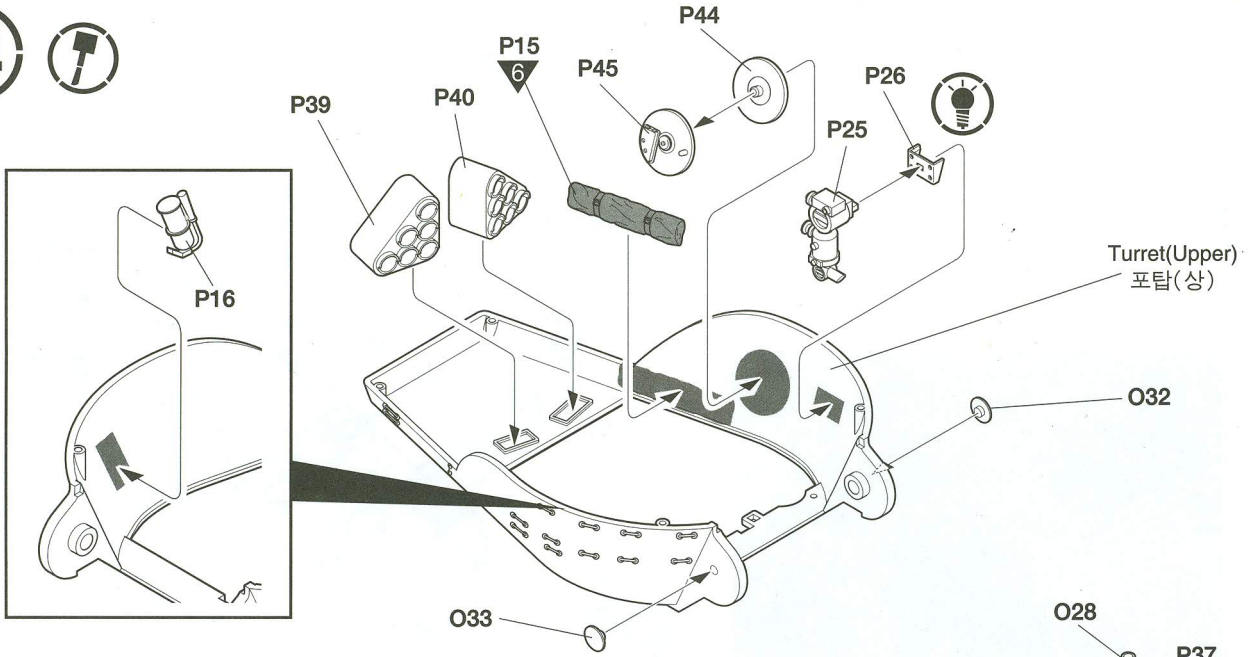

15

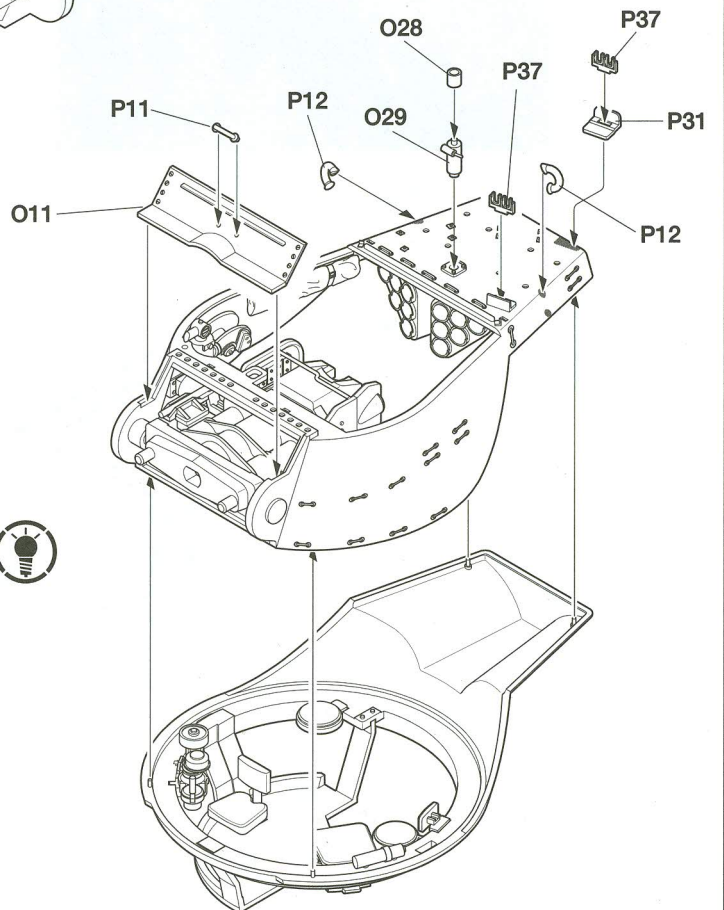
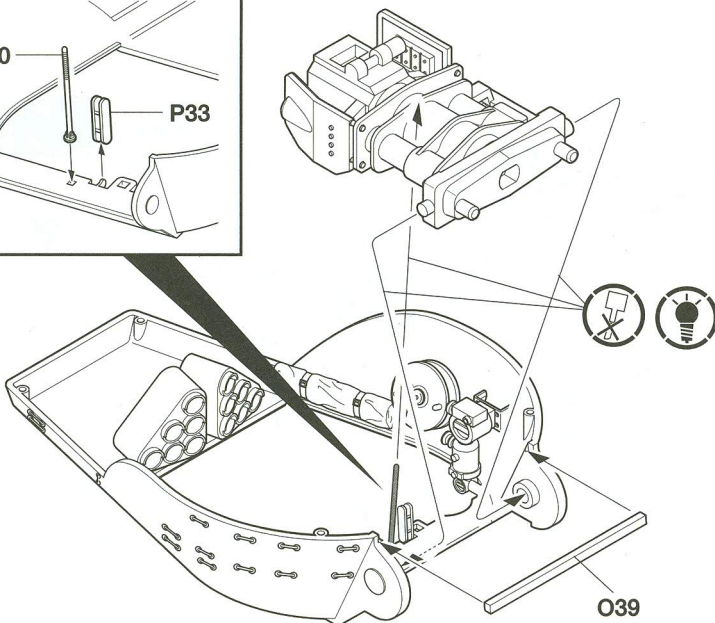
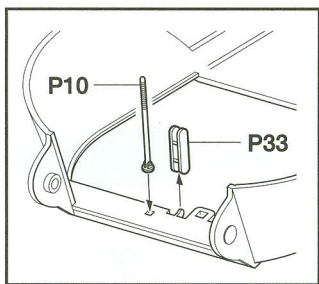

16 

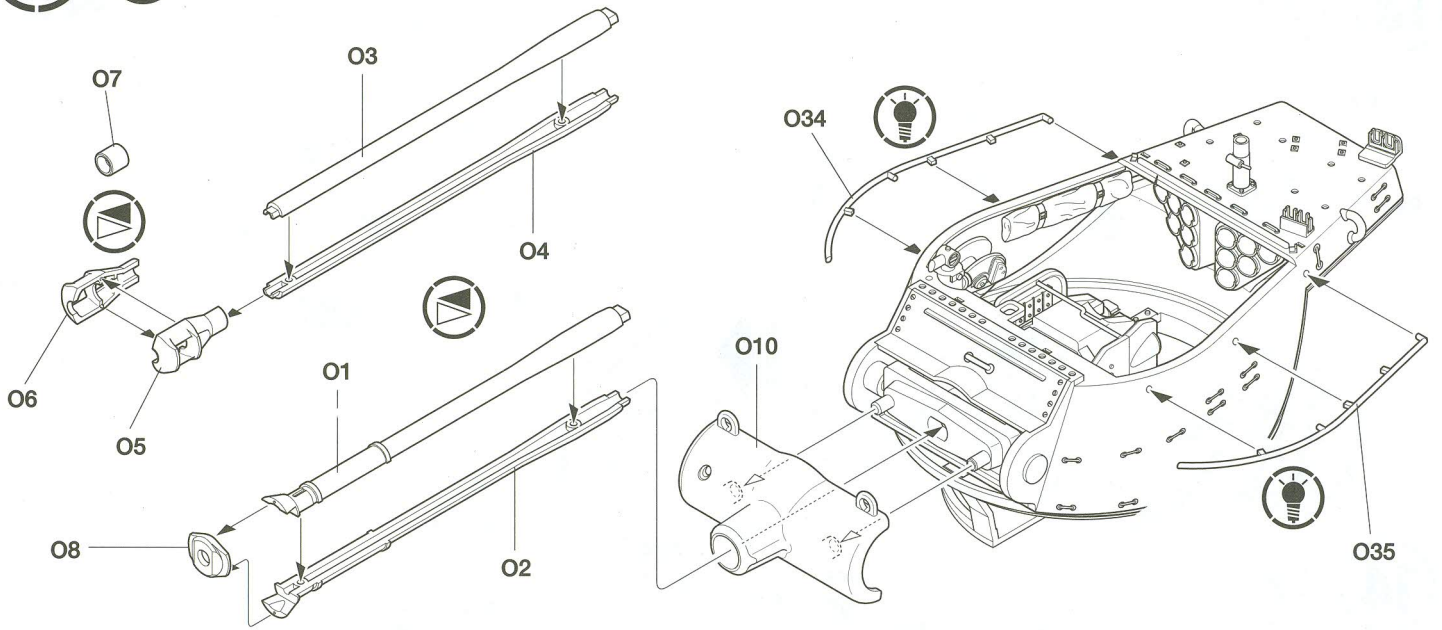

17 

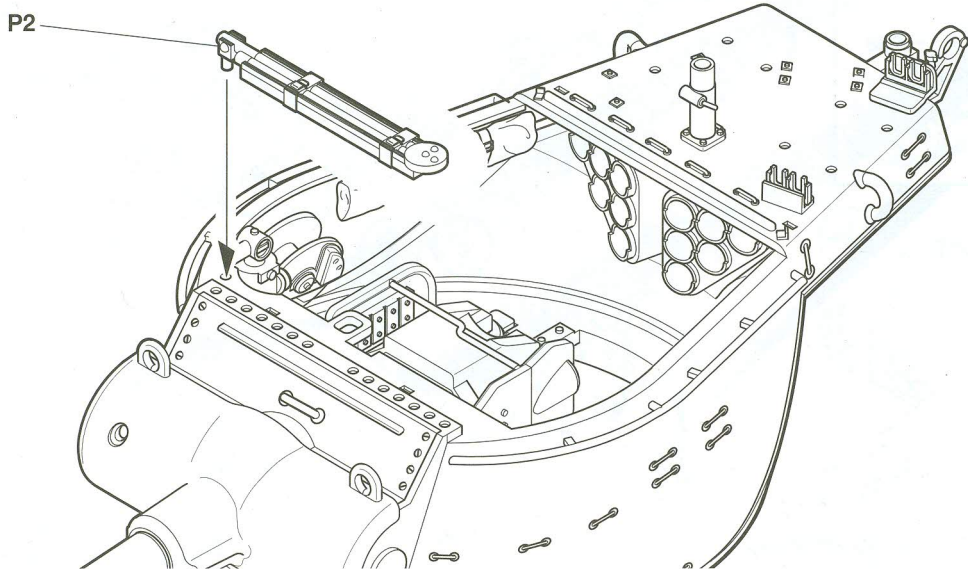
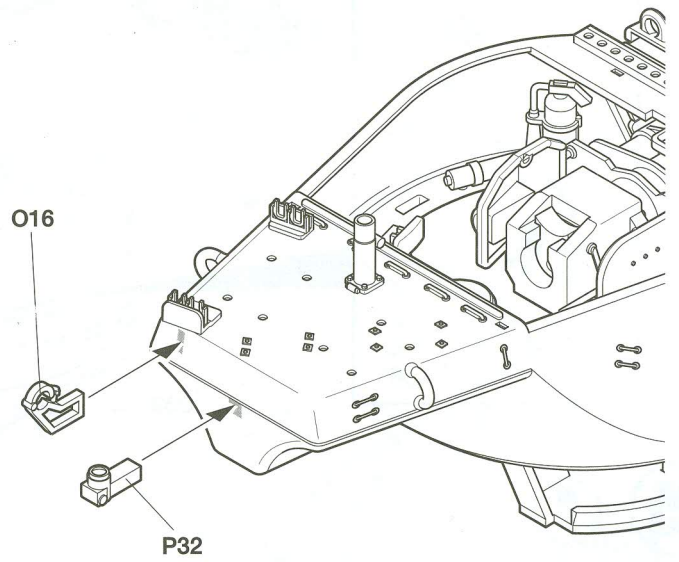
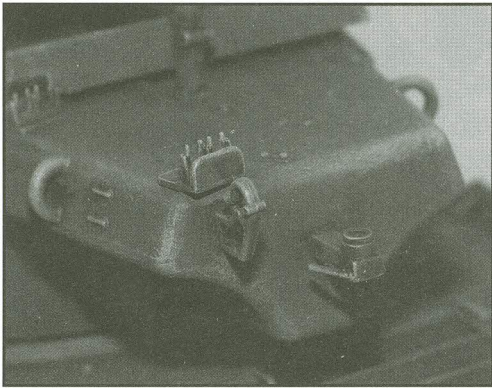

18 

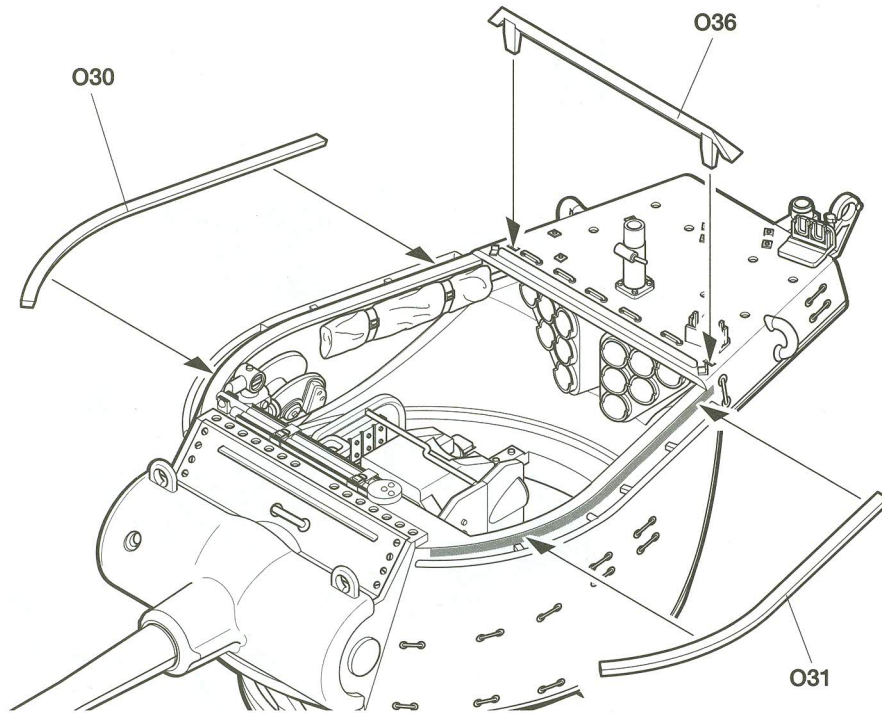

19 

※ () is opposite number.
()는 반대측 번호입니다.

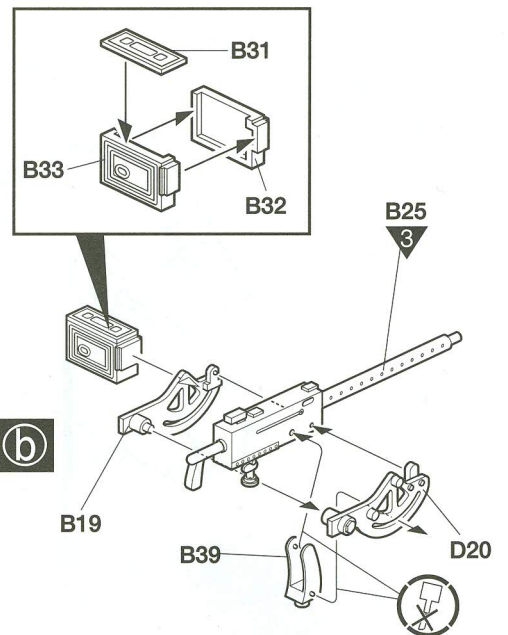
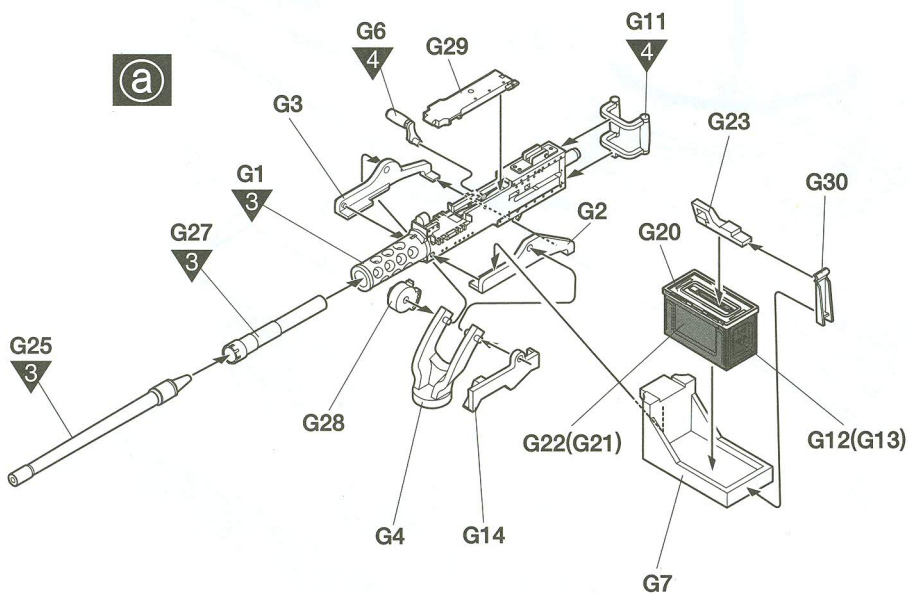

● ACCESSORIES

악세서리

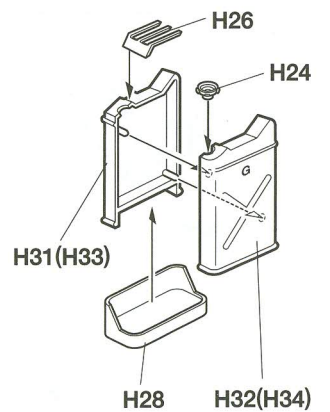
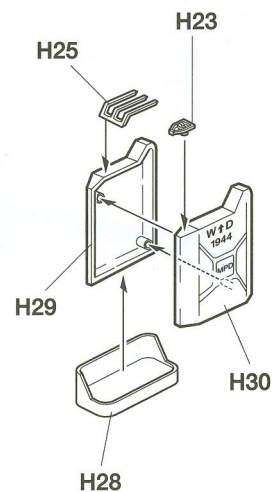
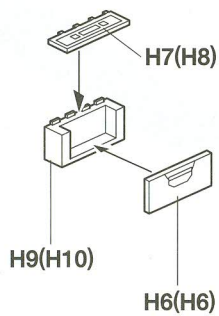
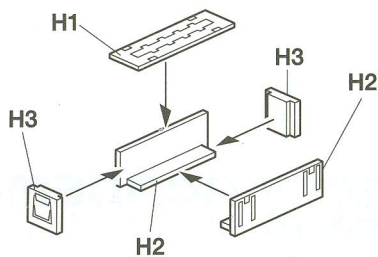
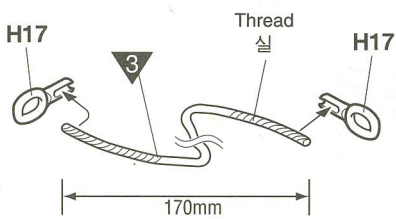

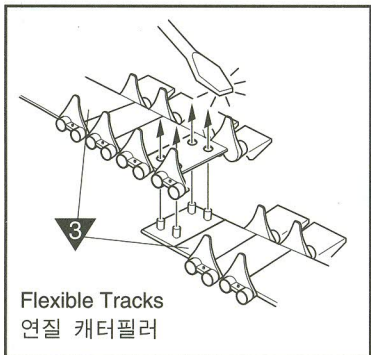
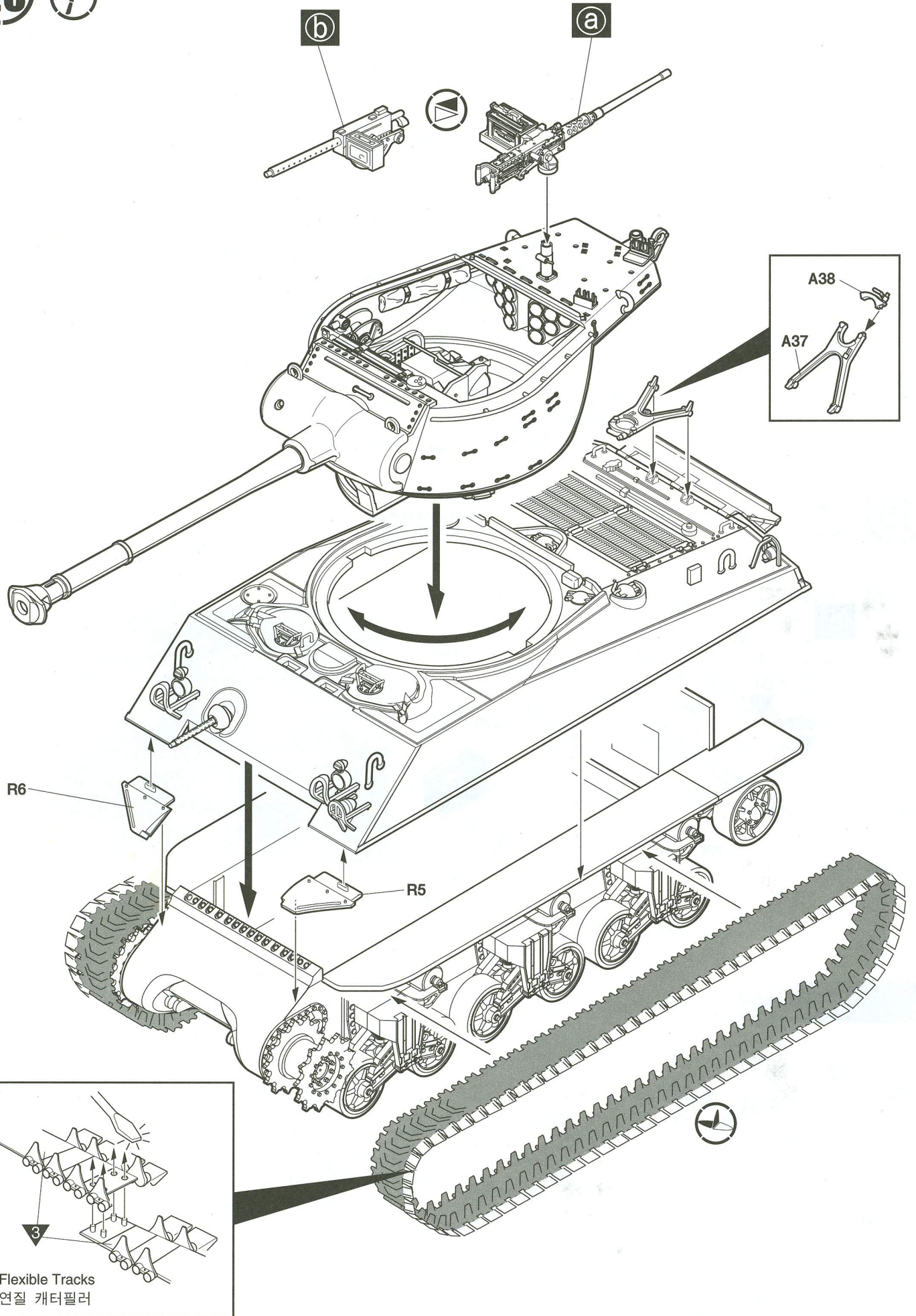

* Melt pins together with a heated screw driver.
볼에 달근 드라이버 등으로 핀을 녹여 고정시켜 연결합니다.

1 Unknown area, early 1945.
1945년 초, 지역불명

※ () is opposite number.
()는 반대측 번호입니다.

Body color
차체 색상 ▼ 5

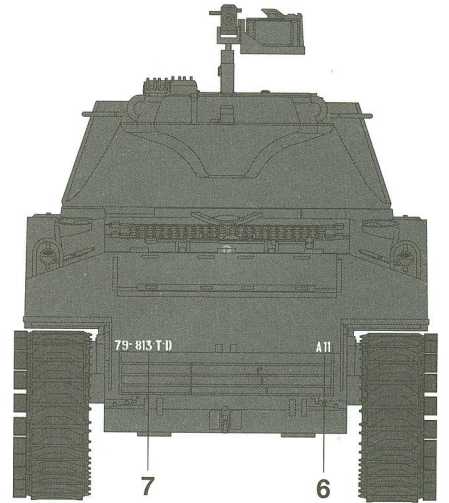
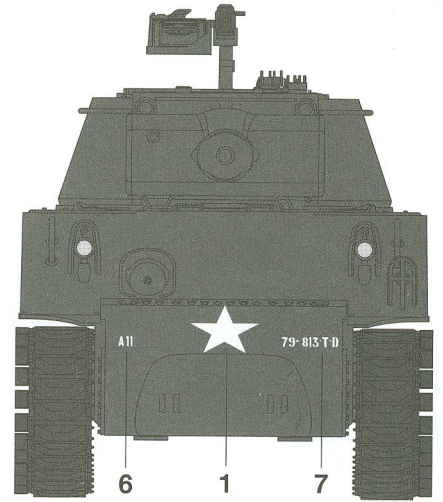
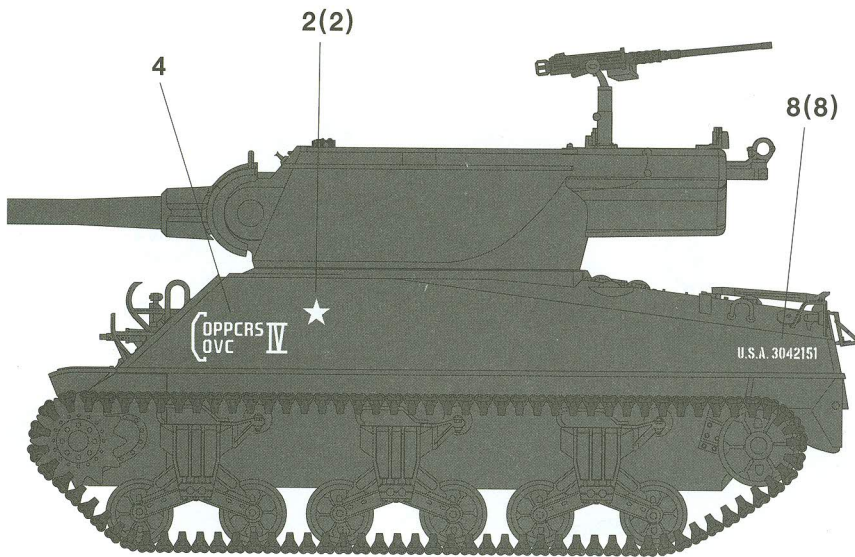

2 Unknown area, early 1945.
1945년 초, 지역불명

Body color
차체 색상 ▼ 5

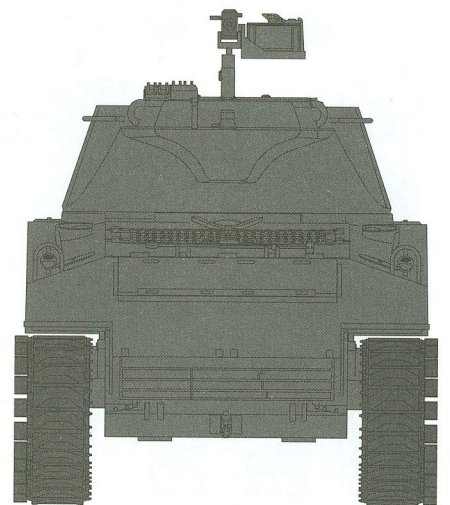
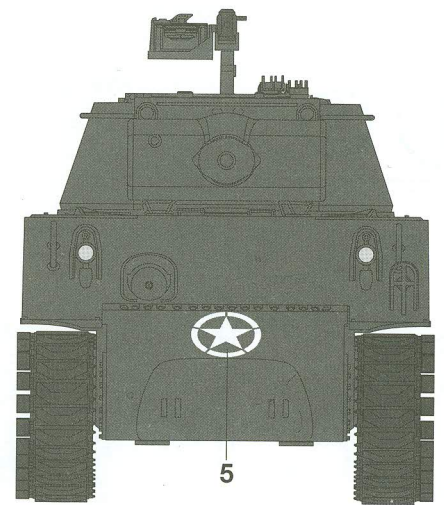
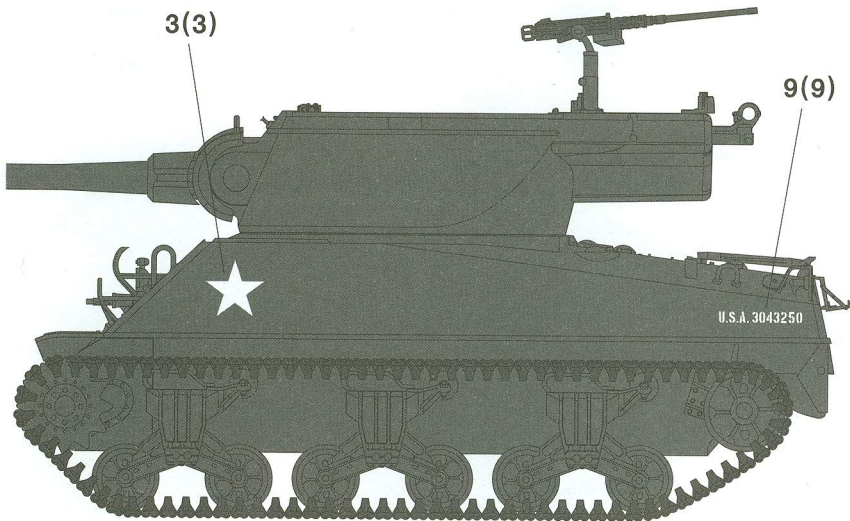

a x2

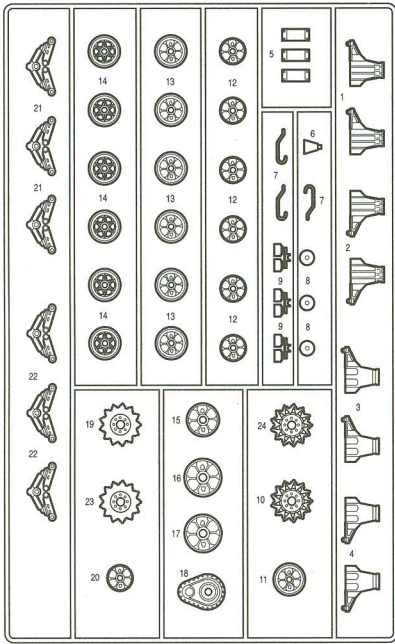

G

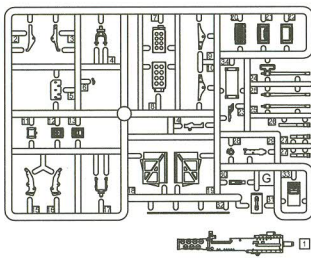

A

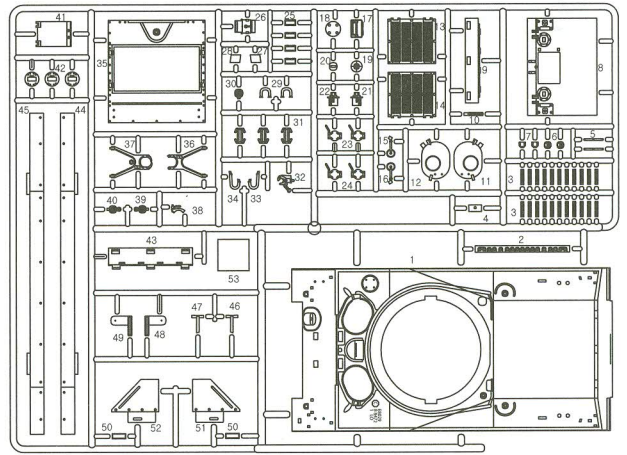

B

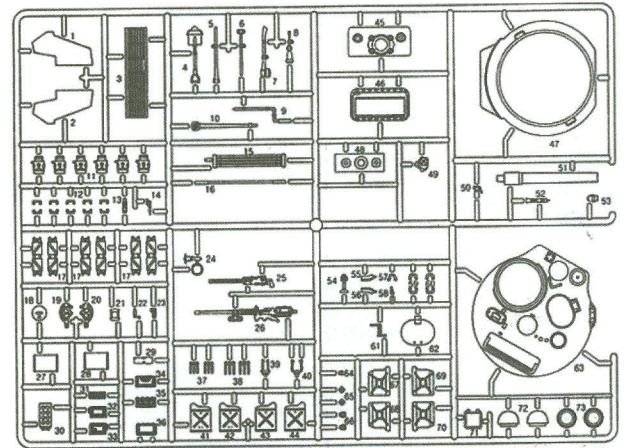

F

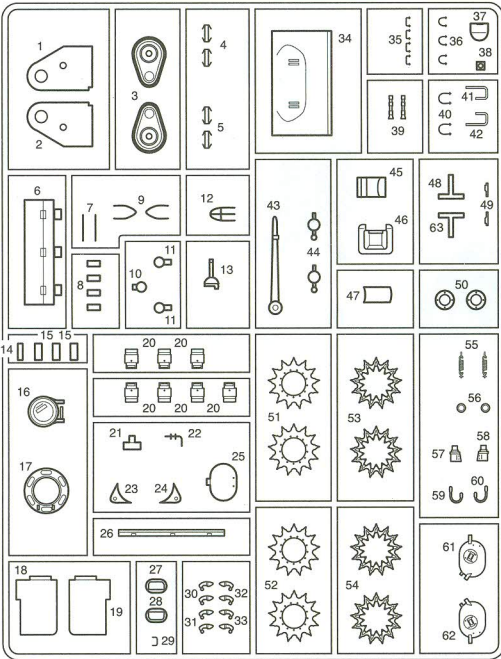

C

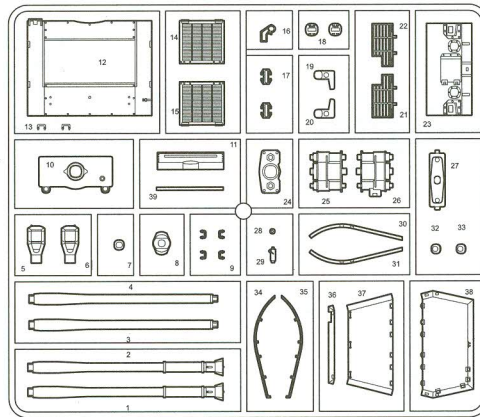

H

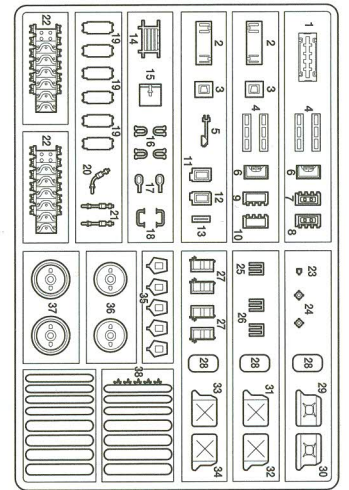

●Photo Etched/에칭

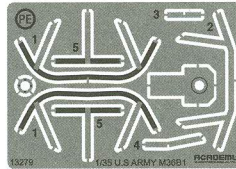

●Decal/전사지

●Turret(Upper)/포탑(상)

●Turret(Lower)/포탑(하)

●Lower Hull/하체

●Thread/실

●Flexible Tracks X2/연질 캐터필러X2

R

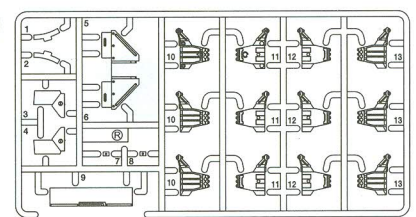

P

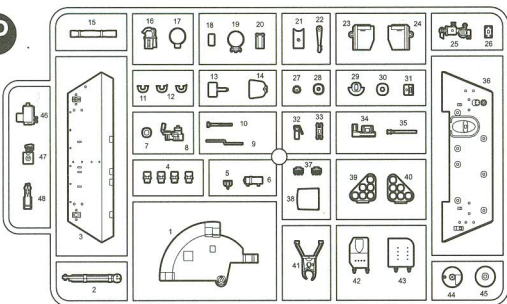

●Unused parts/불필요 부품

a1X4, a2X4, a3X4, a4X4, a5X6, A3X22, A15, A16, A18X2, A25X2, A26, A36, A42, A44, A45, A51, A52, B1, B2, B3, B11X2, B12X3, B17X6, B21, B22, B23, B24, B26, B27, B28, B29, B30, B34, B35, B36, B40, B45, B46, B47, B48, B49, B50, B51, B53, B54, B55, B56, B57, B58, B59X2, B60X2, B61, B62, B63, B71, B72X2, B73X2, F4X2, F5X2, F6, F7X2, F8X4, F10, F11X2, F13, F14, F15X3, F16, F17, F20X7, F22, F23, F24, F25, F26, F27, F28, F29, F30X2, F31X2, F31X2, F32X2, F33X2, F35X4, F36X3, F37, F38, F39X2, F40X2, F41, F42, F43, F44X2, F45, F46, F47, F48, F49X2, F50X2, F51X2, F52X2, F53X2, F54X2, F55X2, F56X2, F57, F58, F59, F60, F61, F62, F63, G5, G8, G15, G16, G17, G18, G19, G24, G25, G27, G31, G32, G34, H4X3, H5, H11, H12, H13, H14, H15, H16X4, H18X2, H19X6, H20, H21, H22X2, H27.X4, H35X5, H36X2, H37X2, H38, O12, O13X2, O14, O15, O17X2, O18X2, O19, O20, O21, O22, O23, O37, O38, P3, P4X4, P36

ACADEMY
ACADEMY PLASTIC MODEL CO., LTD.
521-1, Yonghyeom-dong, Ulsongbu-si, Gyeonggi-do, Korea
고객상담전화: 031-850-8555