

# FIAT G-91 R3/R4

Desejado ou odiado mas nunca indiferente, foram os sentimentos despertados pelo Fiat G-91R4, nas forças portuguesas combatentes em África e nos guerrilheiros seus oponentes, demonstrando a sua eficácia em combate.

Se para a Força Aérea Portuguesa (FAP) o Fiat G-91 representou uma evolução tão necessária e desejada nas suas capacidades de combate e de alguma forma adequada às suas obrigações em África, para a Luftwaffe, o maior operador da aeronave com perto de 365 unidades, as suas prestações ficavam aquém das suas expectativas e exigências face a um teatro de operações mais evoluído e sofisticado, como era o teatro europeu..

Apesar das suas carências, por mais de duas décadas o Fiat G-91 foi para a FAP a sua guarda avançada e único avião de combate digno desse nome, tendo cumprido sempre com o que lhe foi exigido. Em conjunto com a perícia dos seus pilotos logrou obter vários prémios e galardões em competições e exercícios internacionais.

#### Características:

Comprimento:10,29m      Envergadura:8,56m      Altura:4m      Peso vazio:3674Kg  
Armamento: R4-4 metralhadoras 12,7mm; R3-2canhões Defa 30mm  
Carga de combate até 1860Kg

#### Performance:

Velc. Nível mar: 1073Km/h      Raio de acção de combate: 315Km

Either desired or hated but never with indifference, such were the feelings of Portuguese combatants that fought in Africa and their guerrilla opponents about the Fiat G-91 R4, which gave proof of their effectiveness and performance in combat.

If for the FAP (Portuguese Air Force) the Fiat G-91 was a most wanted and needed improvement in both technical and combat capabilities, particularly regarding FAP commitments in Africa, for German Luftwaffe, the largest operator of the aircraft, its performance left a lot to be desired as the menace they had to cope, the European Theater of Operations facing the Warsaw Pact, was far more demanding and sophisticated.

Despite its shortcomings, for more than two decades the G-91 was the bridgehead of FAP strength and its unique frontline combat aircraft but always fulfilled the tasks demanded and with its pilots skills managed to gain several awards and trophies in international competitions and exercises.



#### Characteristics:

Length: 10,29m      Wing Span: 8,56m      Height: 4,00m  
Weight (Empty): 3674Kg      Armament: R4 -4 12,7mm machine guns; R3: 2 30mm canons      Warload up to 1860Kg

#### Performance:

Sea-level speed: 1073Km/h      Combat radius: 315Km

Soit désiré ou haï mais jamais avec indifférence, ainsi étaient les sentiments des combattants Portugais qui combattaient en Afrique et de la guerrilla adverse au sujet du Fiat G-91 R4, qui donnait la preuve de son efficacité et de ses performances au combat.

Si pour la FAP le Fiat G-91 était le plus demandé et un nécessaire progrès en technique et pour ses compétences au combat, particulièrement en ce qui concerne les responsables de la FAP en Afrique, et pour la Luftwaffe Allemande, la plus grande utilisatrice de l'avion, ses performances laissaient un peu à désirer face à la menace qu'ils avaient à couvrir, le théâtre des opérations Européennes face au pacte de Varsovie, était de loin le plus demandé et sophistiqué.

En dépit de ses insuffisances, pendant plus de deux décades le G-91 a été la tête de pont de la FAP et son unique avion de combat de première ligne mais accomplissant toujours les tâches demandées et avec l'adresse de ses pilotes à le maîtriser lui ont permis de gagner plusieurs prix et trophées lors de compétitions ou exercices internationaux.

#### Caractéristiques

Longueur: 10,22 m      Envergure: 8,56 m      Hauteur: 4,00 m      Poids: 5674 Kg  
Armement R4: 4 mitrailleuses de 12,7 mm      R3: 2 canons de 50 mm      Charge utile: plus de 1860 Kg

#### Performances

Vitesse au niveau de la mer: 1073 Km/h      Rayon d'action: 315 Kms

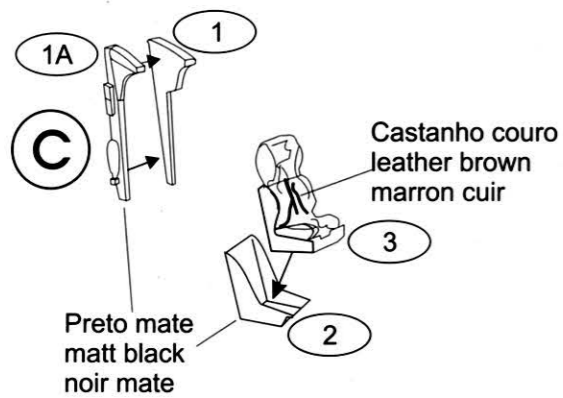
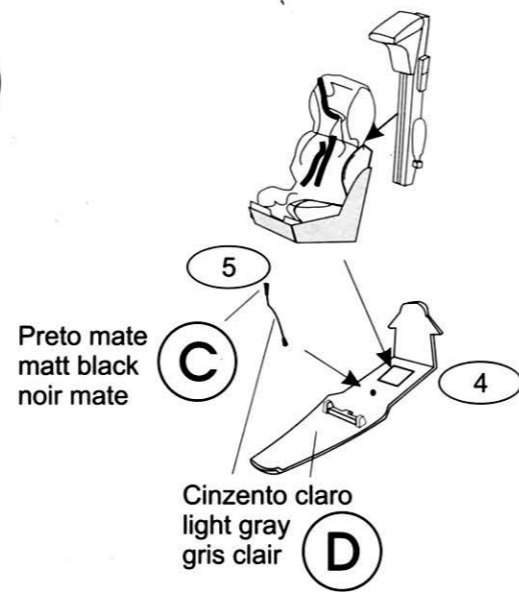
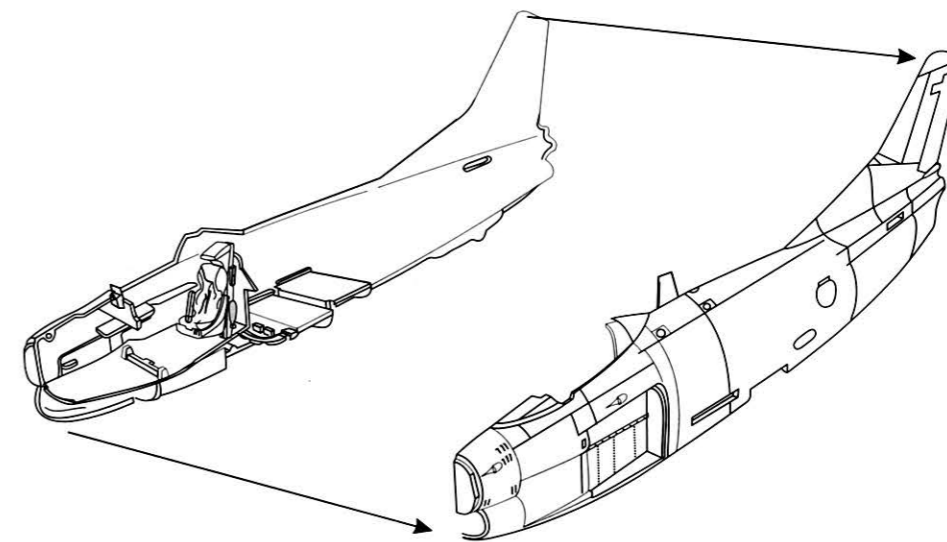
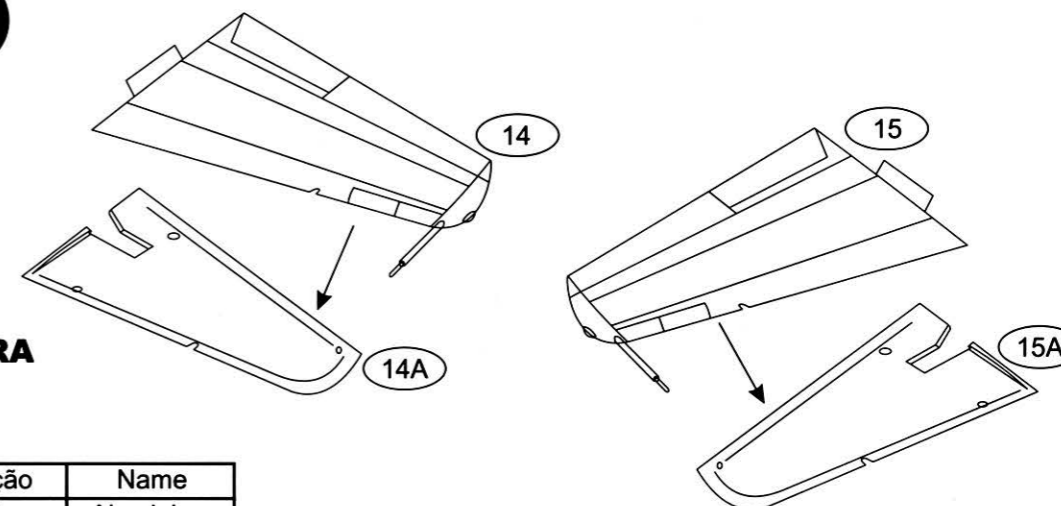
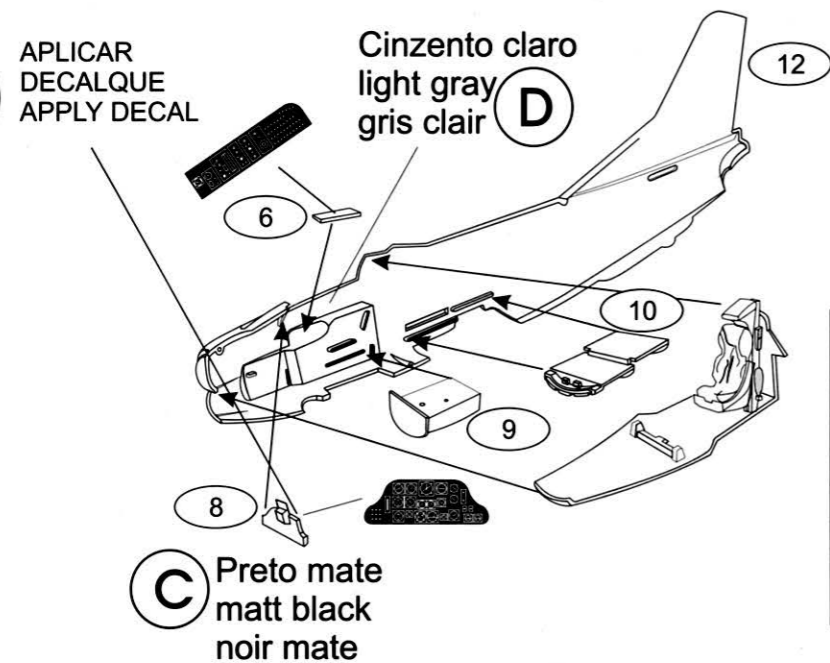

**1****2****5****6****3**

**MAPA DE REFERÊNCIA PARA A PINTURA  
PAINTING COLOR CHART**

	Humbrol	Gunze Sangyo	Revell	Testors	F. Standard	Designação	Name
A	56	218	99	1781		Alumínio	Aluminium
B	11	H8	90	1546	17178	Prata	Silber
C	33	H12	8	1749	37038	Preto Mate	Matt Black
D	64		75	1726	36307	Cinzeno Claro	Light Gray
F	117	H303		1713	34102	Verde Oliva	Olive Green
G	118	H310	382	1742	30219	Castanho	Tan
H	156		12	1514	36173	Cinzeno Neutro	Neutral Gray
I	116	H309		1710	34079	Verde Tropa	Olive Drab

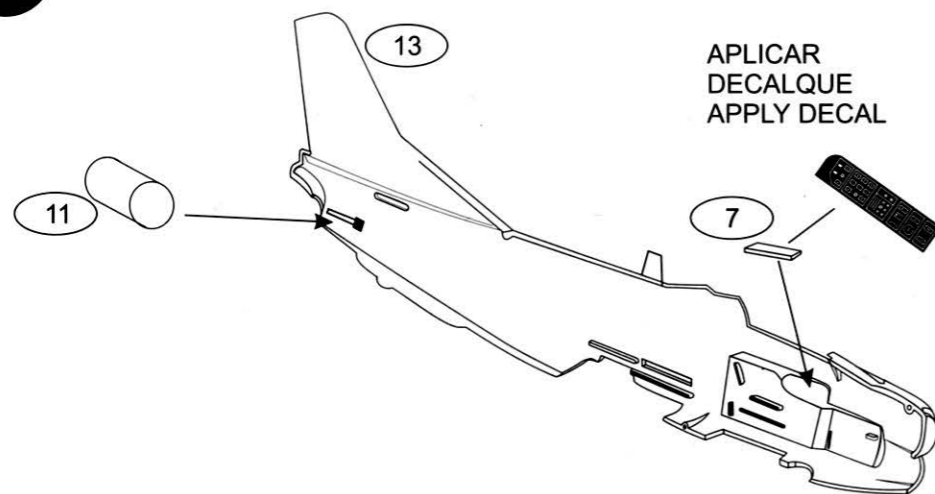
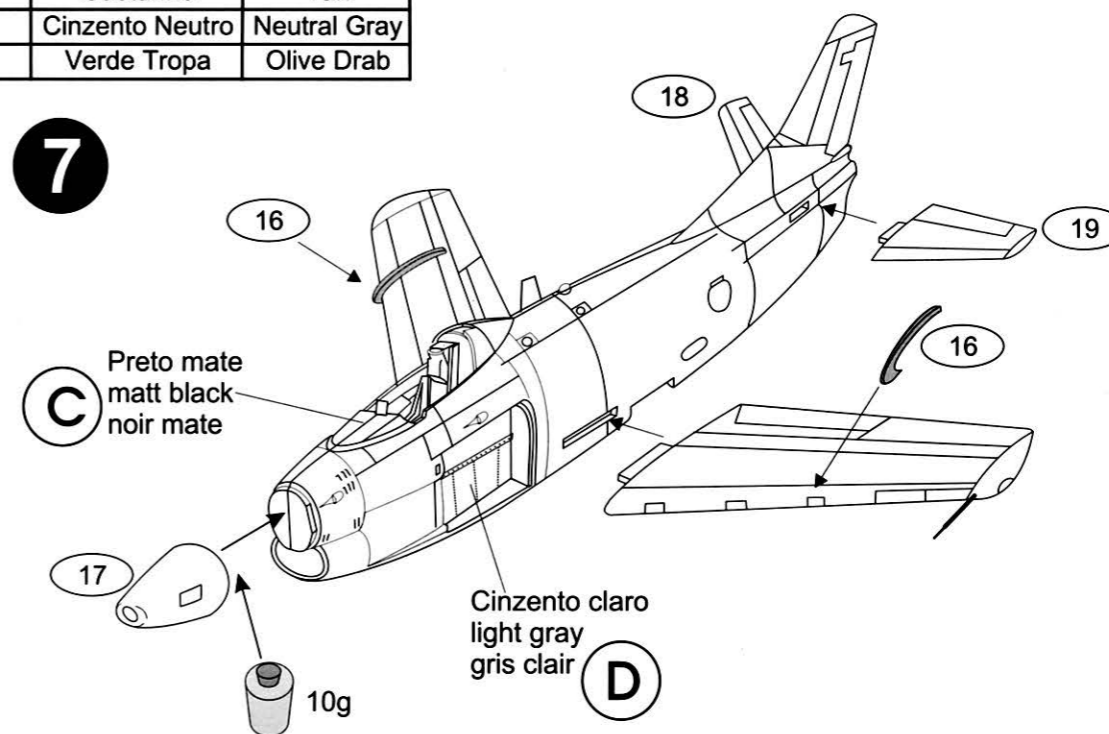
**4****7**

8

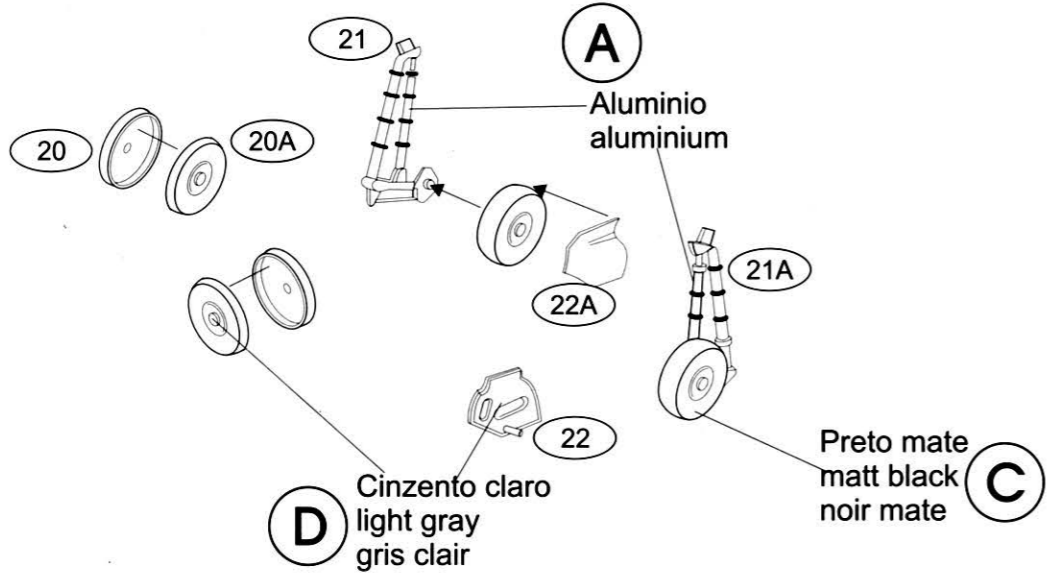

12

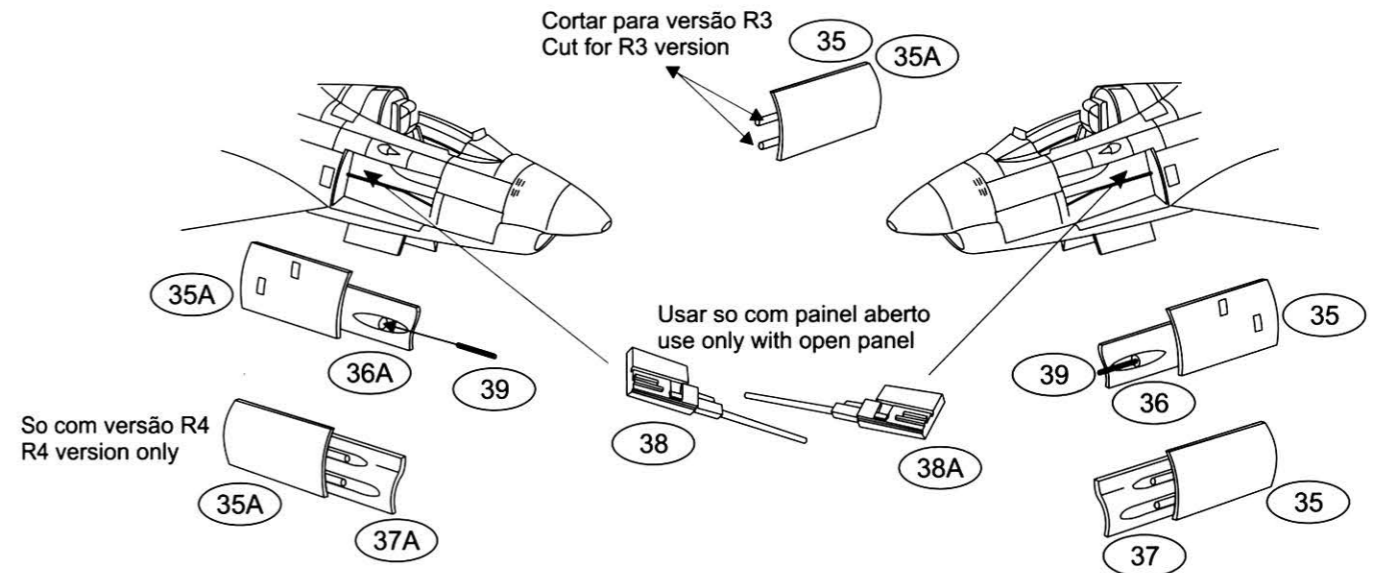

9

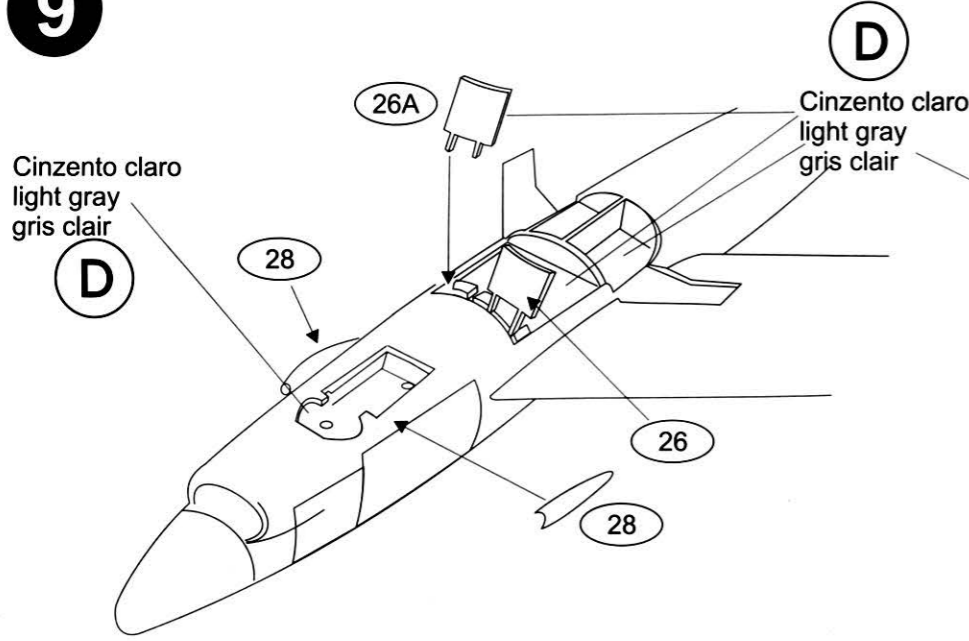

10

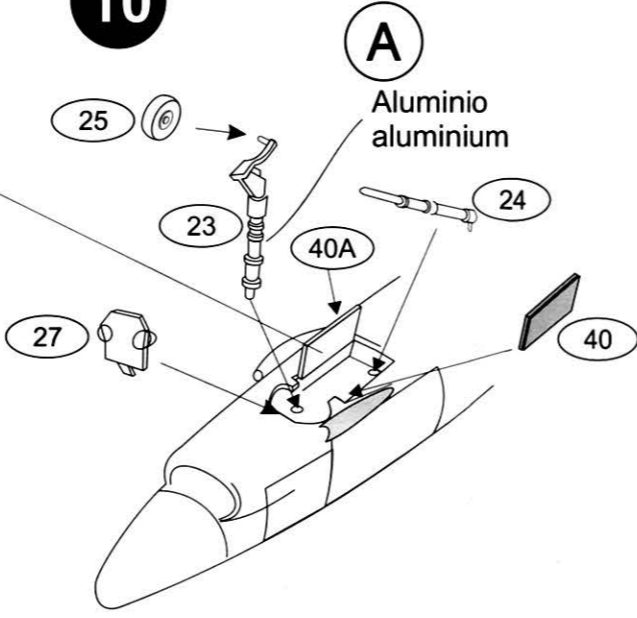

13

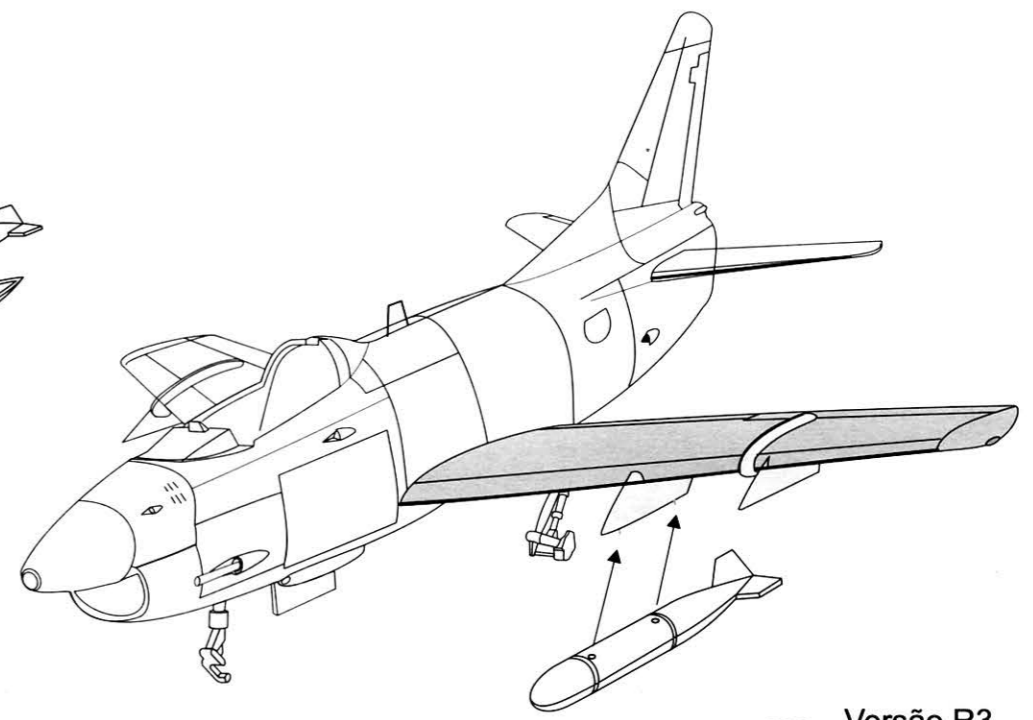
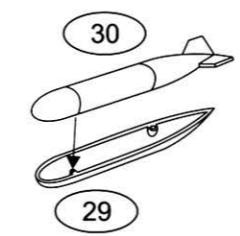

11

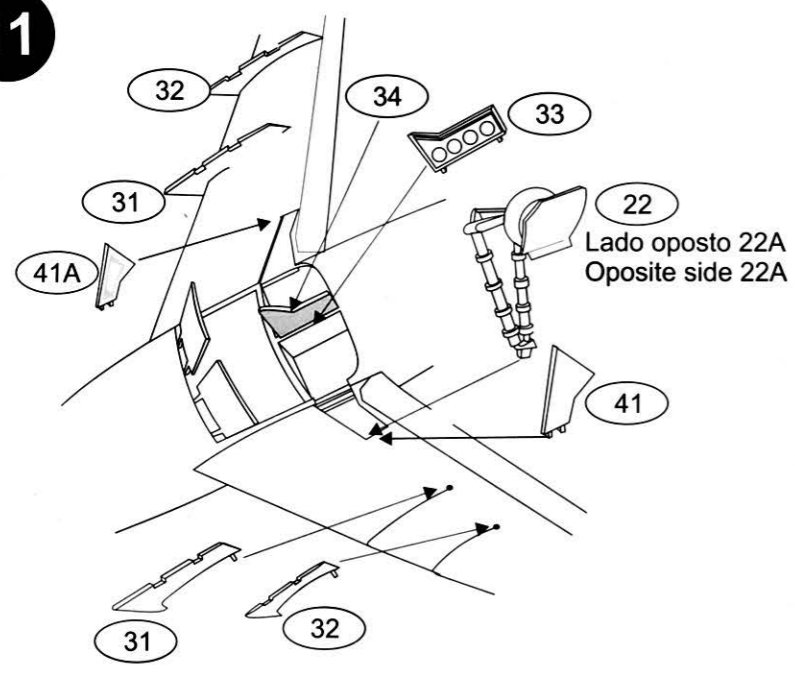

14

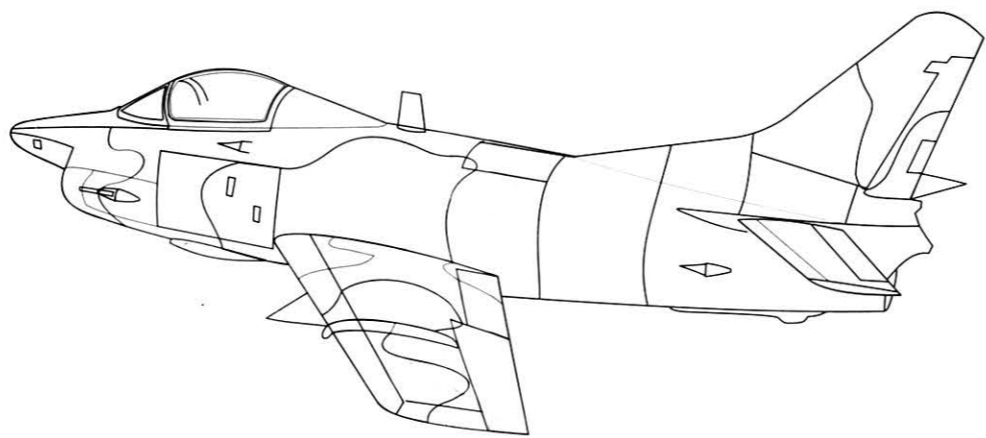
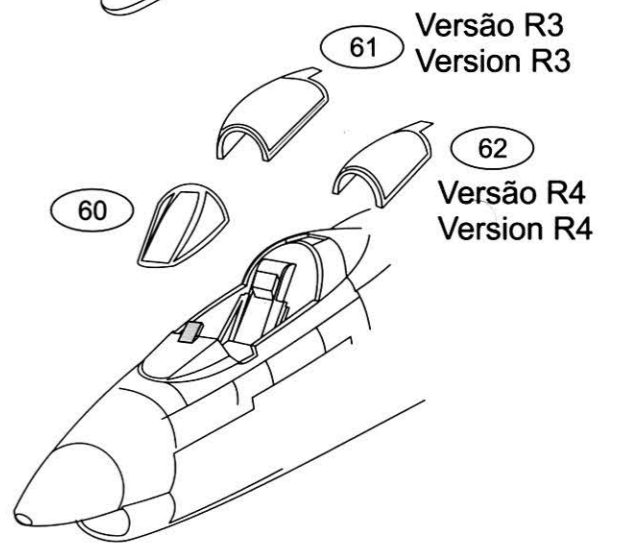

**DECALQUES E PINTURA  
DECALS AND PAINTING**

**Fiat G-91 R3 - Portugal**

Tome nota: a colocação de marcas de serviço nas aeronaves varia de avião para avião por isso aconselhamos a consultar referências para a colocação dos decalques fornecidos. Esta Informação está também disponível no site da Ocidental:  
<http://www.occidental.com>

Please take note: service markings and stenciling vary from aircraft to aircraft so please check references to apply the decals supplied. This information is also available in the OCIDENTAL's internet site at:  
<http://www.occidental.com>

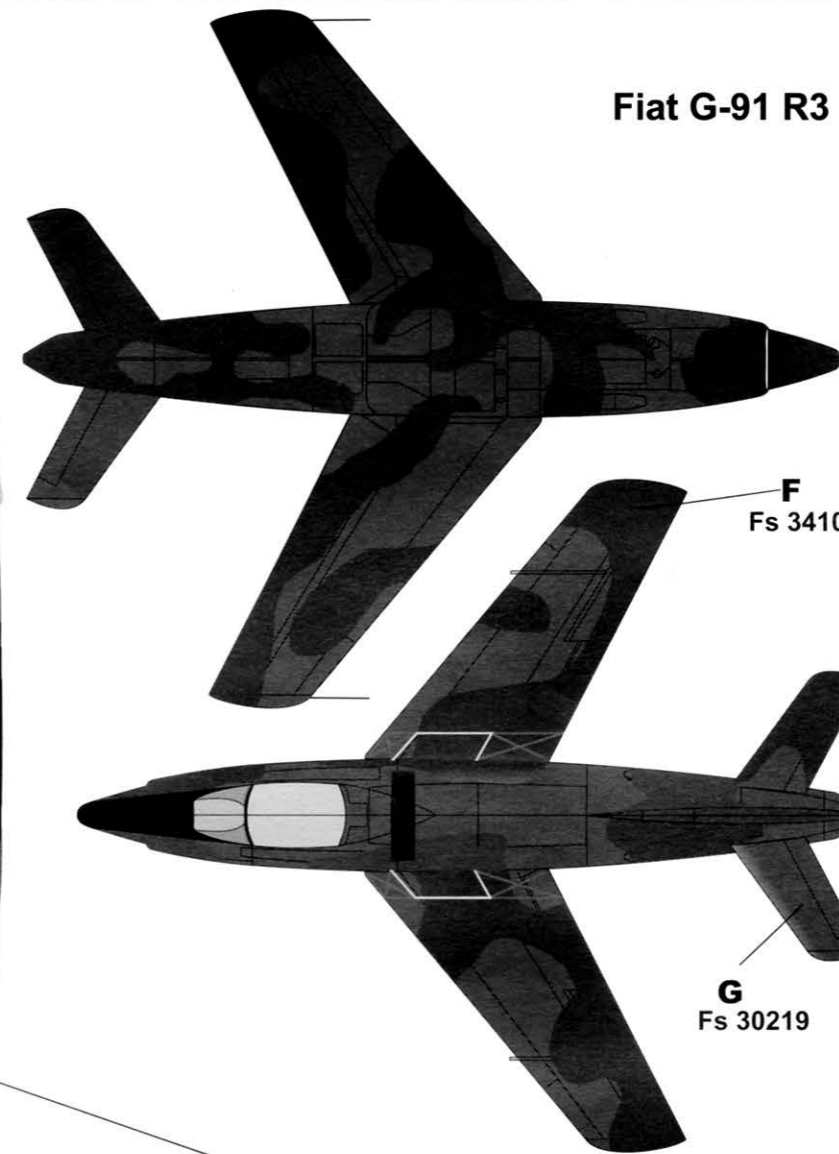
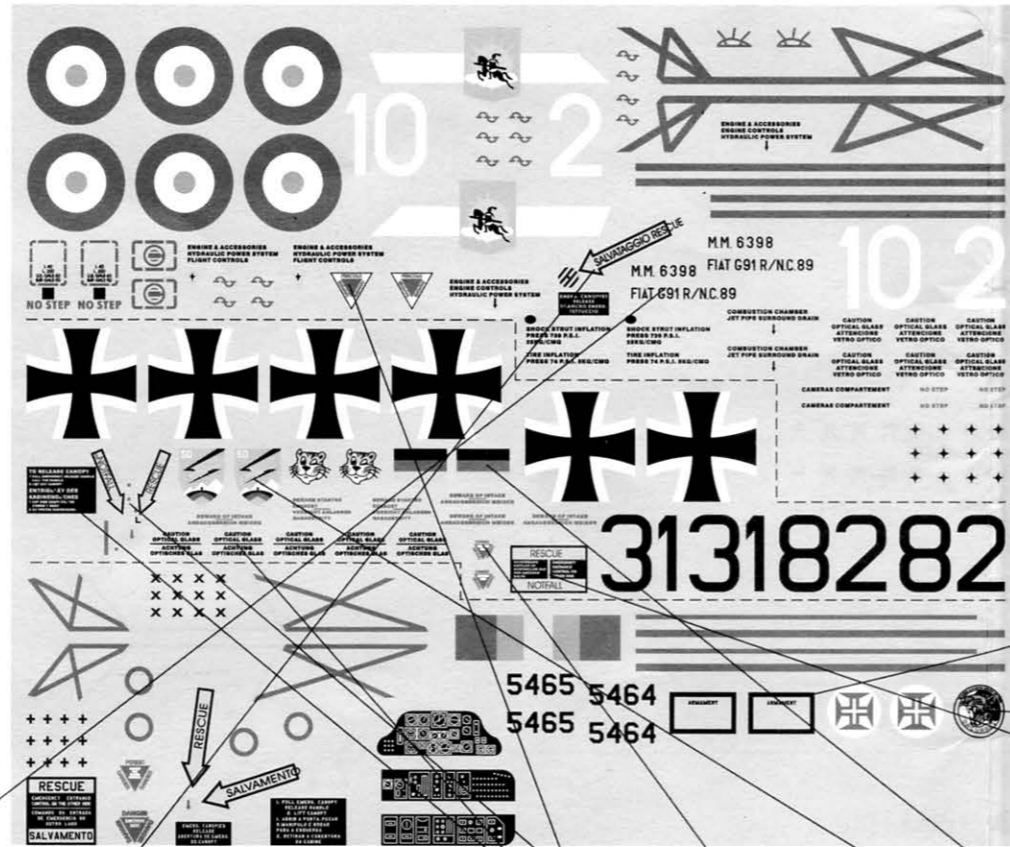

**F**  
Fs 34102

**G**  
Fs 30219

**Decals "Carpena"**

**Fiat G-91 R4 - Itália/Italy**

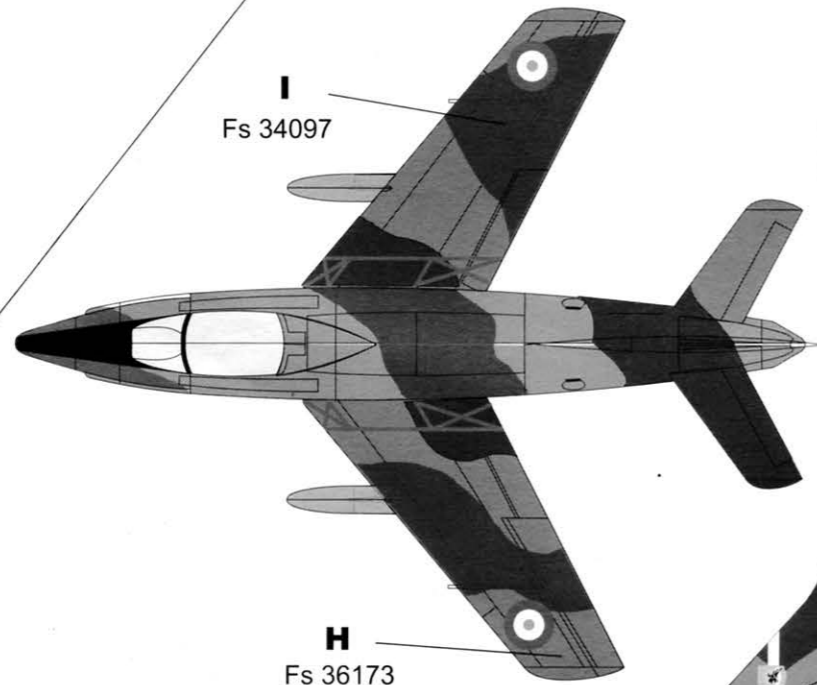
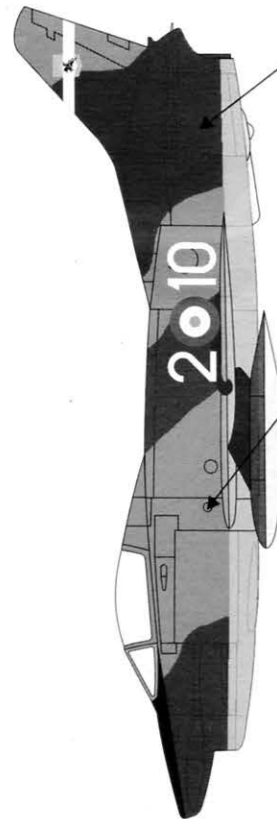

**I**  
Fs 34097

**H**  
Fs 36173

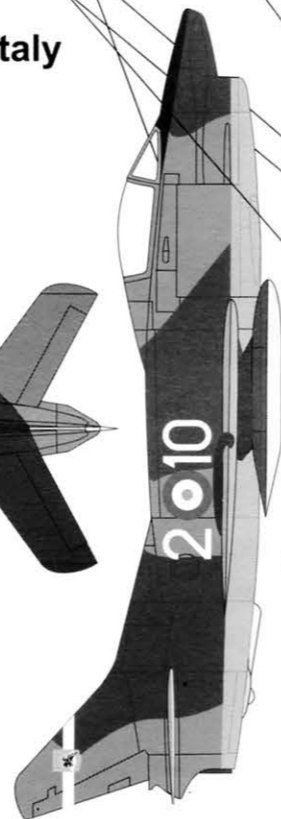

**B - SILVER  
PRATA**

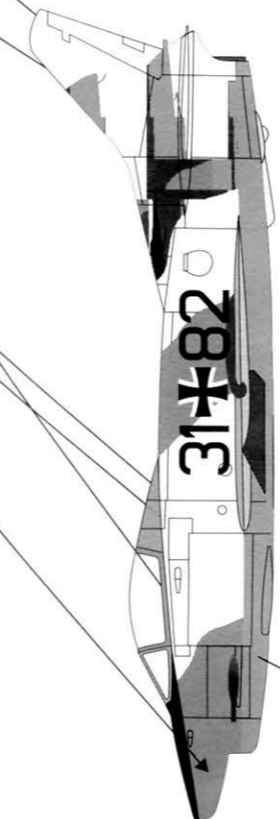

**Fiat G-91 R3 - Alemanha/Germany**

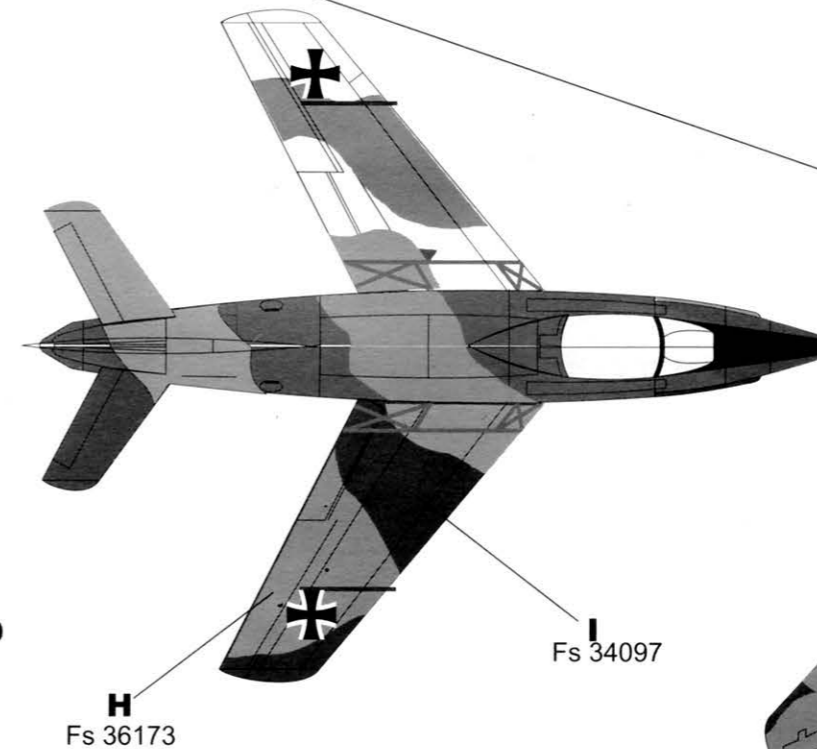

**H**  
Fs 36173

**I**  
Fs 34097

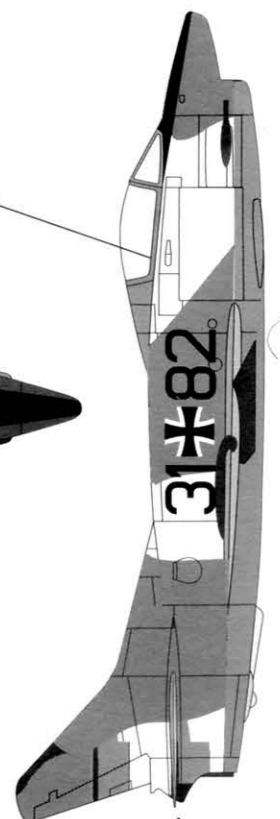

Para instruções a cores consulte o site da OCIDENTAL REPLICAS EM: <http://www.occidental.com>  
FOR COLOR INSTRUCTIONS VISIT OUR WEB SITE: <http://www.occidental.com>