

RUSSIAN T-72B3 MAIN BATTLE TANK 2017

MOSCOW VICTORY DAY PARADE



ITEM NO: UA72102

Accepted in 1985 and mass-produced since 1988, the T-72B(M) MBT (Ob.187) has protection level comparative to that of the contemporary T-80U, but has a noticeably poorer FCS and vision aids and is underpowered. It is the last model of the (in)famous T-72 line, because the T-72BU MBT, successor to T-72B(M), received a new designation, T-90. However, T-72B(M) tanks and older T-72s upgraded to T-72b(M) standard are the most numerous tanks fielded with the Russian military. With the current financial problems, it will likely remain a widespread use well into the 21st century.

In addition to the basic model, there exists the T-72BK command variant that has been fielded since 1987. The variant differs in radio and navigational equipment, as well as the presence of an auxiliary power unit.

Dimensions	L9,530/6,860 x W3,460 x H2,226 x 470 clearance
Weight	44.5 metric tons
Crew	3
Engine	840 hp V-84-1 diesel 1 kW AB-1 aux.unit (T-72BK)
Max Road Speed	60 km/h
Max X-country Speed	45 km/h
Power/Weight	18.9 hp/tn
Ground Pressure	0.9 kg/sq cm
Range	500 km
Obstacle negotiation	
Fording depth	1.2 m on the move/5 m with OPVT (snorkel)
Trench width	2.8 m
Vertical obstacle	0.8 m
Maximum gradient	30°
Weapons	
Main Weapon	125mm 2A46M smoothbore
Stabilization	2E42-2 Zhasmin
Rate of fire	6-8 rounds/min
Ammunition	45 rounds (22 in carousel)
Ammunition Types	APFSDS, HEAT, HEF

●READ BEFORE ASSEMBLY

1. When you use glue or paint, do not near flame, and use in a well-ventilated room.
2. Take extra care in handling photo etch parts in order to avoid injury.
3. When you take parts off the runner frame, use modeling scissors and trim excess plastic with a cutter or a file.
4. Glue and paint are not included.
5. This product is only suitable for experienced more than 14 years old.

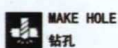
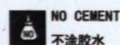
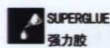

DECAL APPLICATION

1. Cut off decal from sheet.
2. Dip the decal in tepid water 40° C for about 10 sec. and place on a clean cloth.
3. Hold the backing sheet edge and slide decal onto the model.
4. Move decal into position by wetting decal with finger.
5. Press decal gently down with a soft cloth until excess water and air bubbles are gone.

●装配之前仔细阅读:

1. 勿於近火处使用胶水或油漆, 并打开窗户保持空气流通。
2. 取蚀刻片时应特别注意安全, 防止利边划伤手指。
3. 从胶架中取出部件时, 应用模型专用剪, 并用界刀或小锉除去多余的胶料。
4. 请使用塑料胶水和油漆, 模型内不含。
5. 本产品不适合14岁以下没有经验的模型爱好者。

水贴纸的使用:

1. 从水贴纸上剪下印花。
2. 将印花放入温水中浸10秒, 然后放在干净布上。
3. 拿着印花纸将印花移到模型上。
4. 手指蘸水将印花移到适当的位置。
5. 用软布轻压印花直至不干, 汽泡消失。

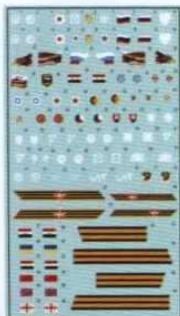
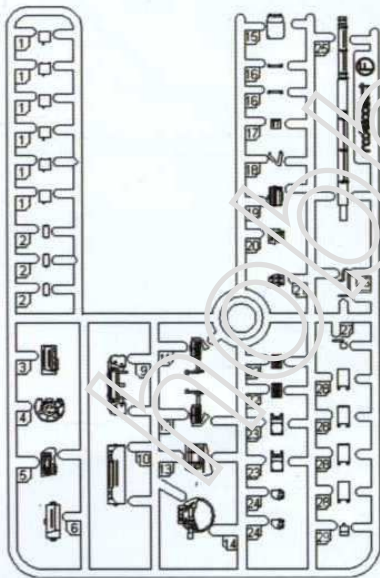
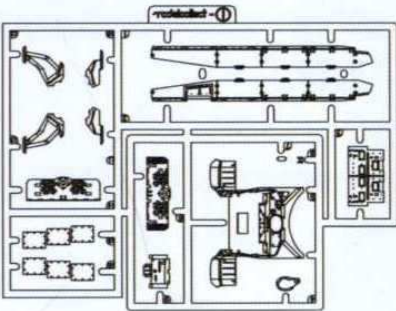
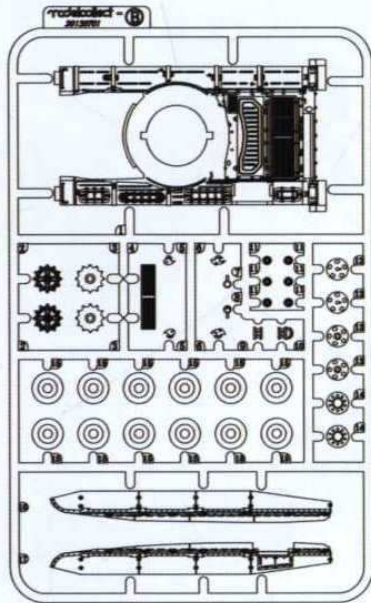

Decal1

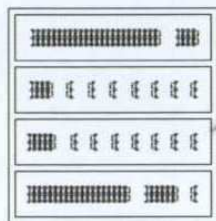
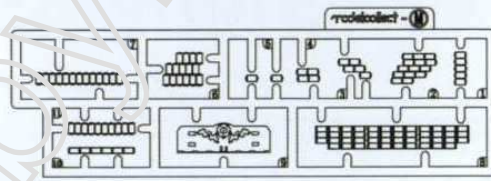
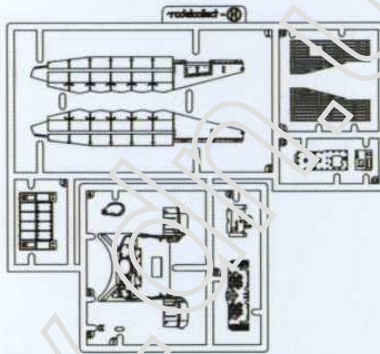
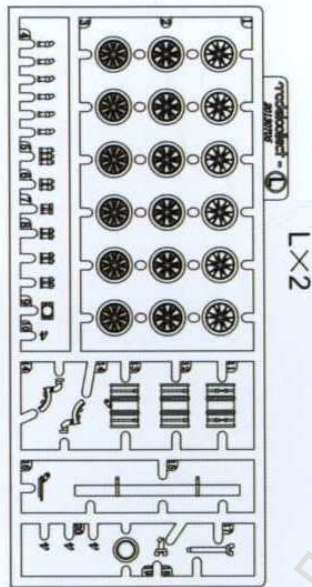

Track X 2

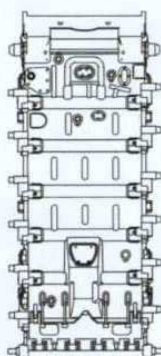

Metal hull

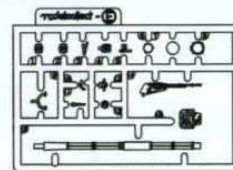
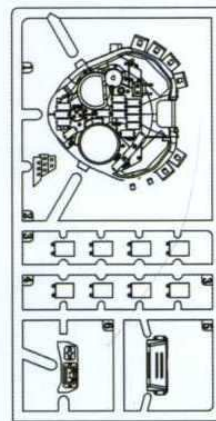
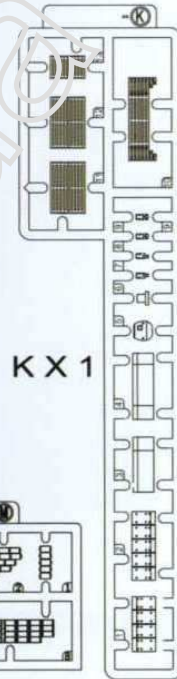
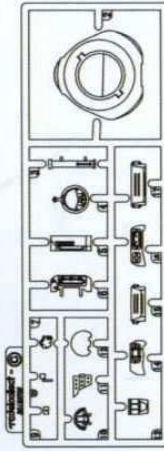

1 组装炮塔 1
Attaching turret parts 1

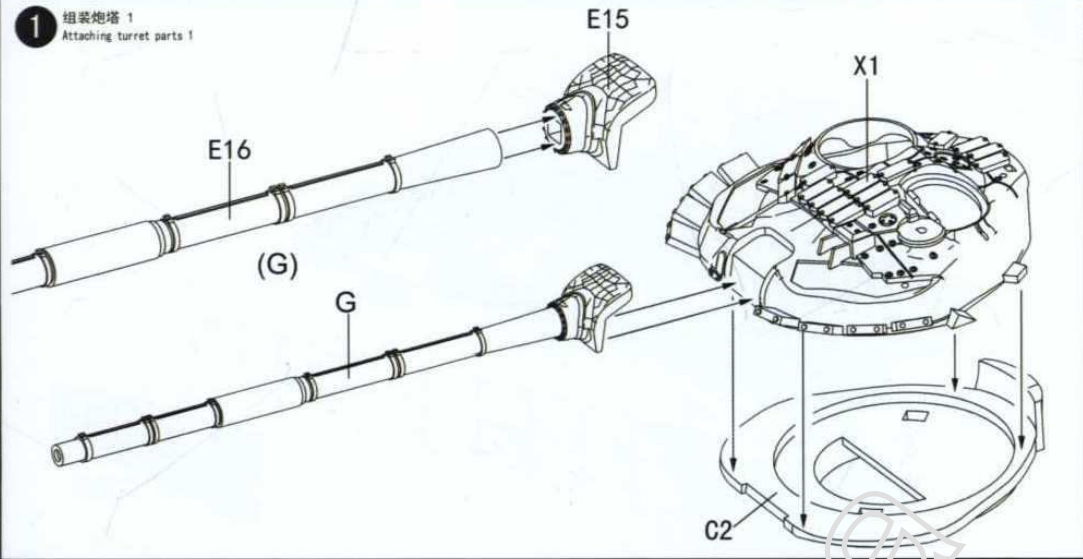

2 组装炮塔 2
Attaching turret parts 2

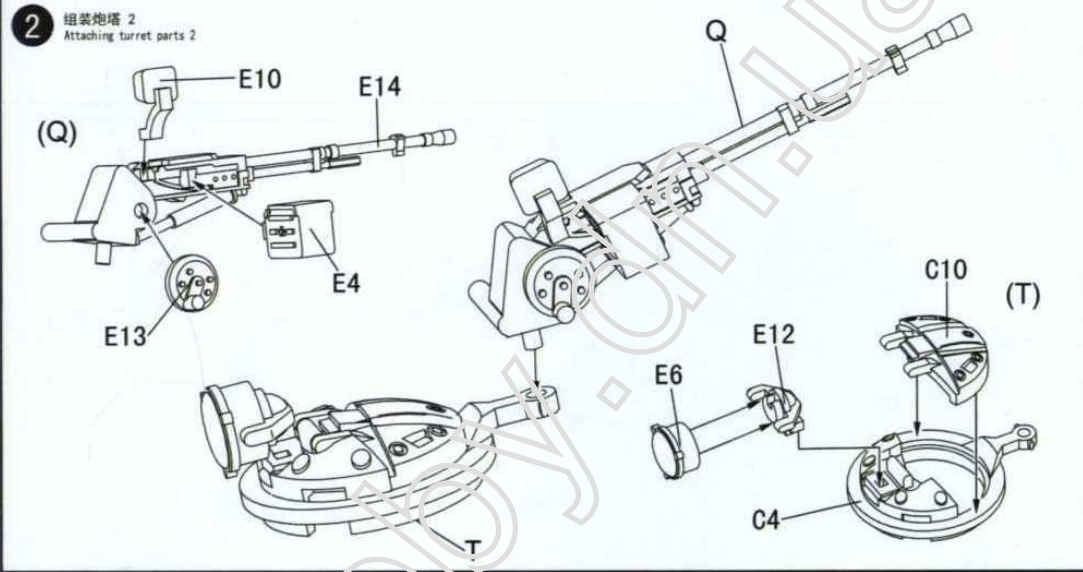

3 组装炮塔 3
Attaching turret parts 3

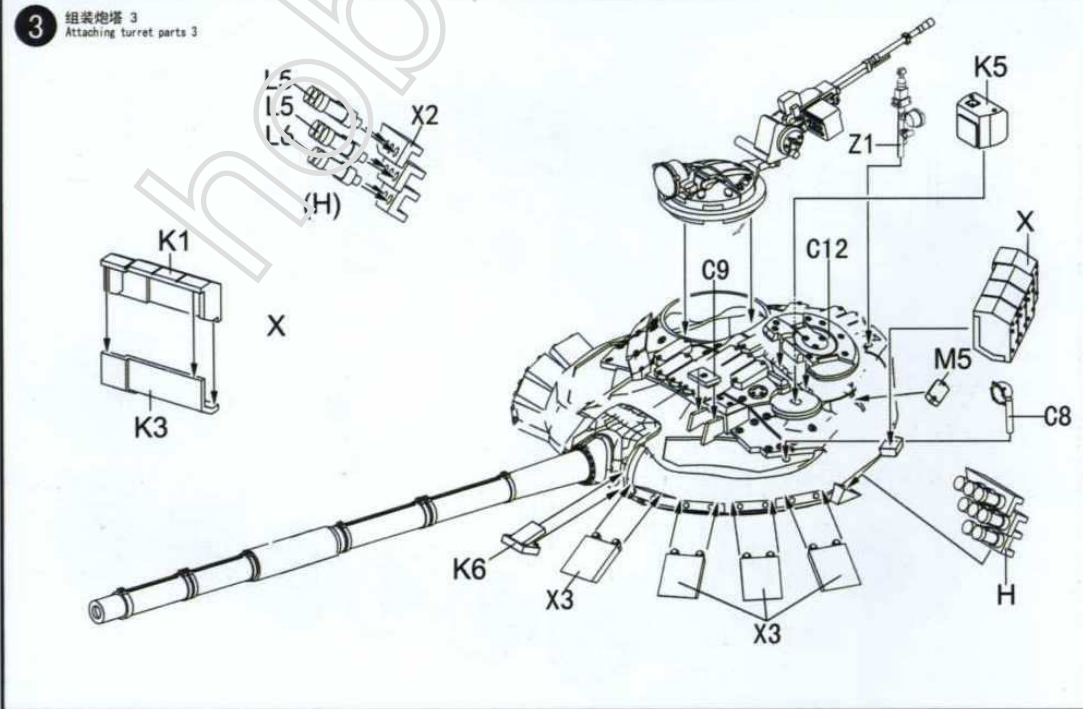

4 组装炮塔 4
Attaching turret parts 4

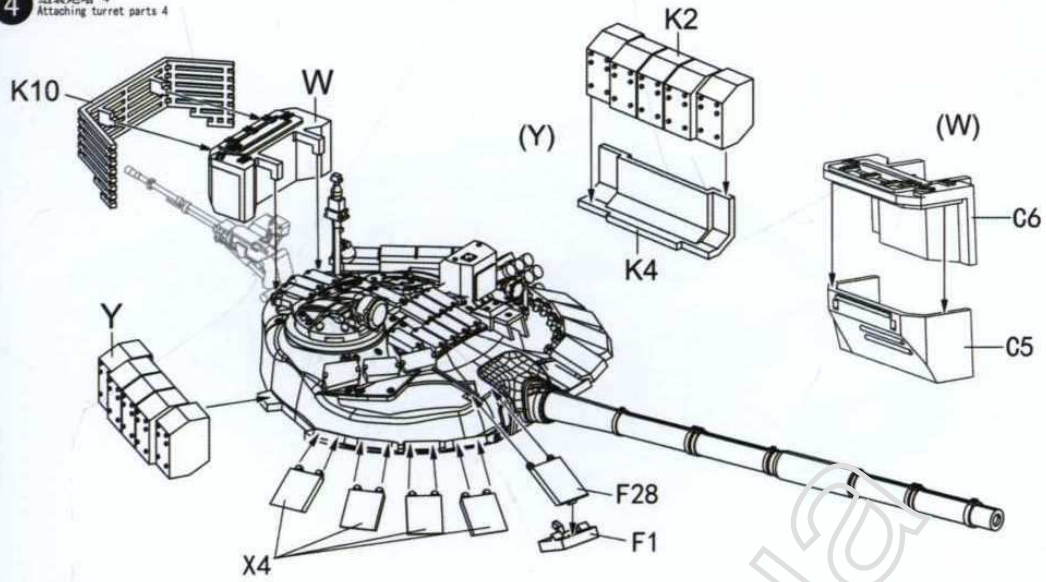

5 组装车体 1
Attaching hull 1

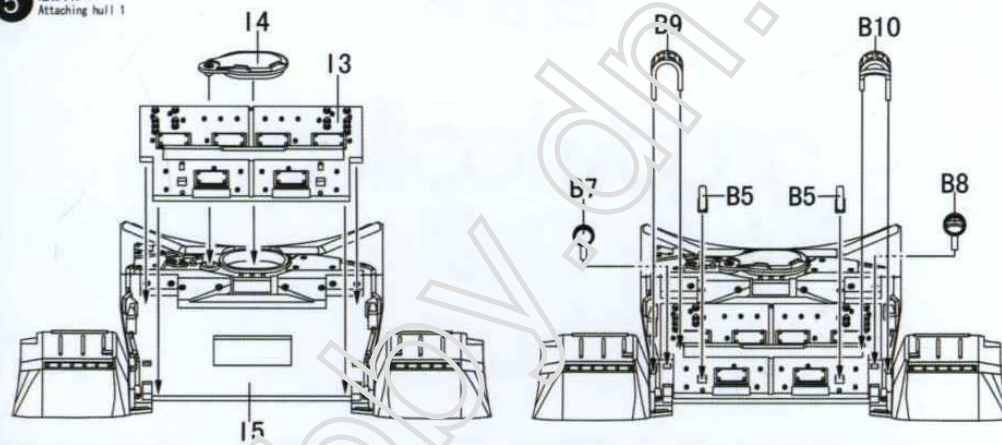

6 组装车体 2
Attaching hull 2

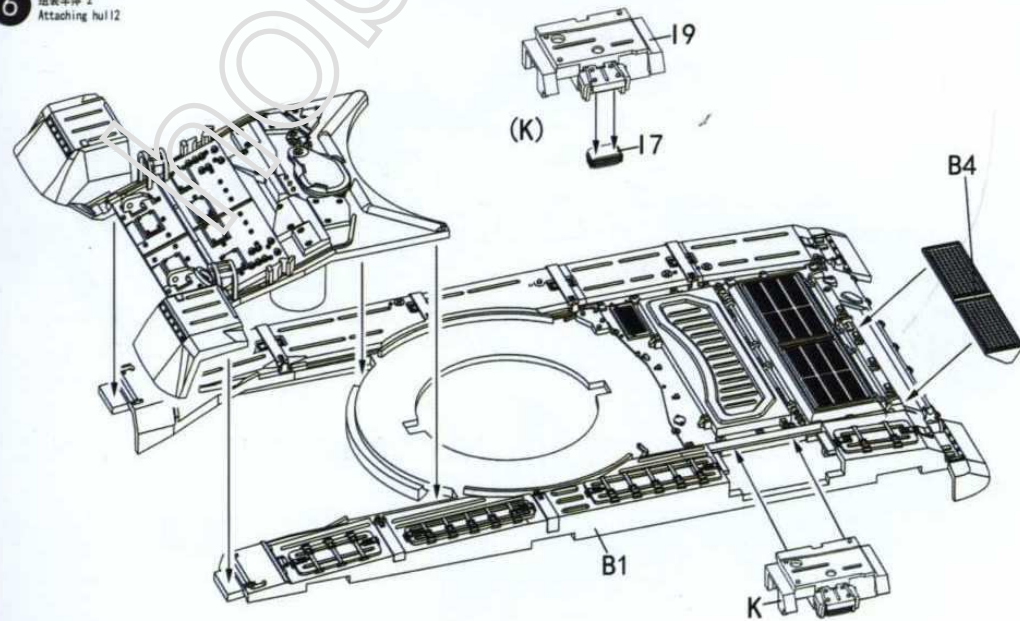

7 组装车体 3
Attaching hull 3

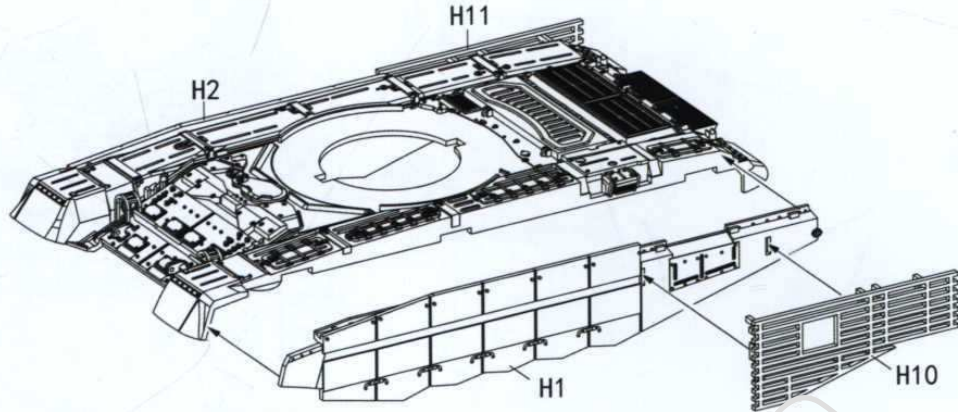

8 组装车轮1
Attaching wheels 1

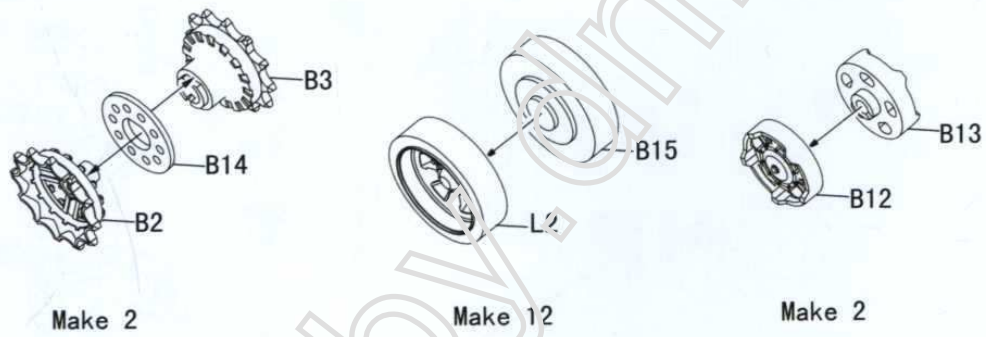

9 组装车轮2
Attaching wheels 2

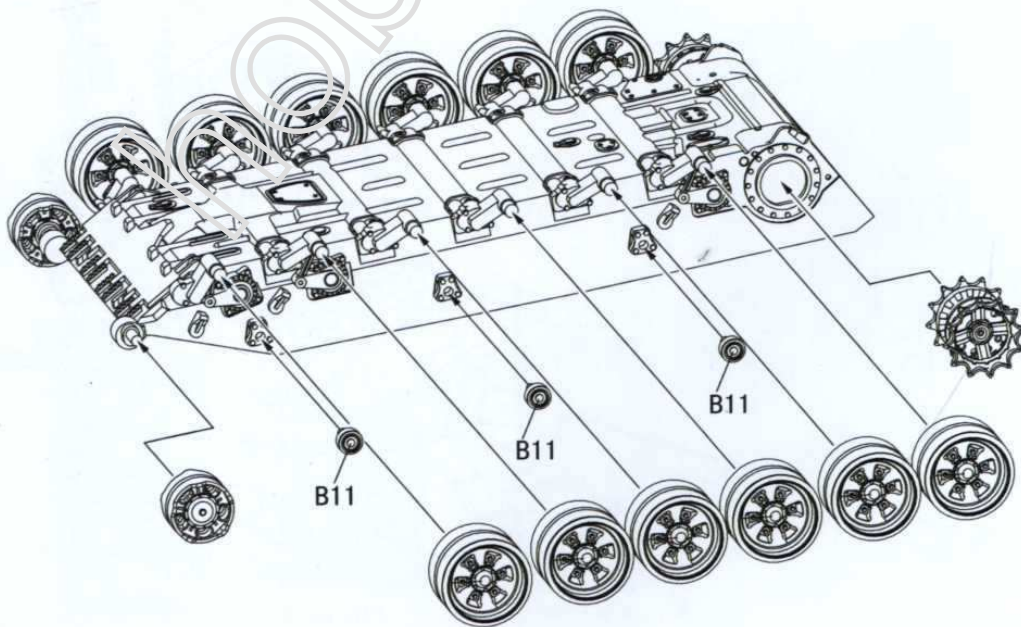

10 组装车尾
Attaching tail of the hull

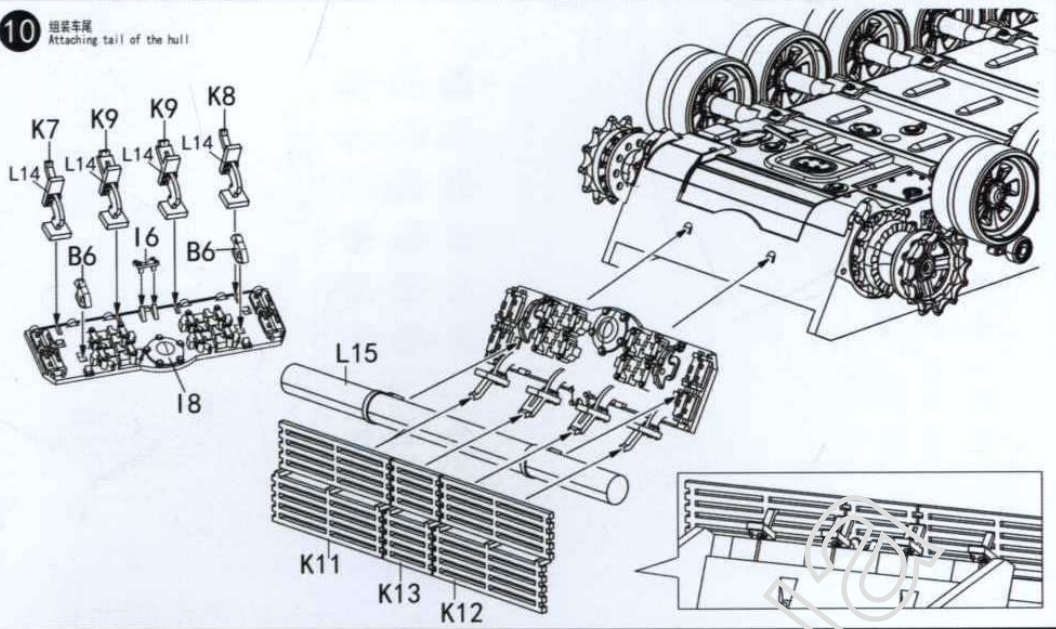

11 组装拼接履带
Attaching tracks

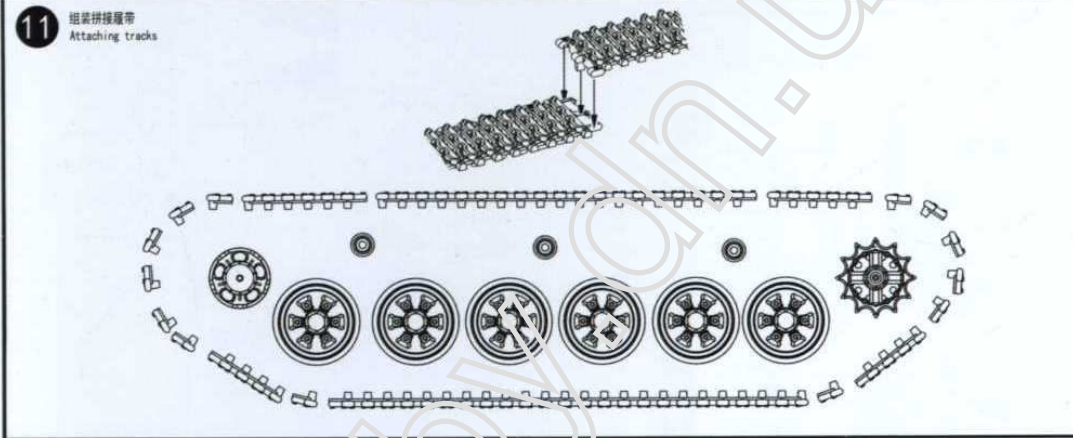

12 组装炮塔和车体
Attaching turret and hull

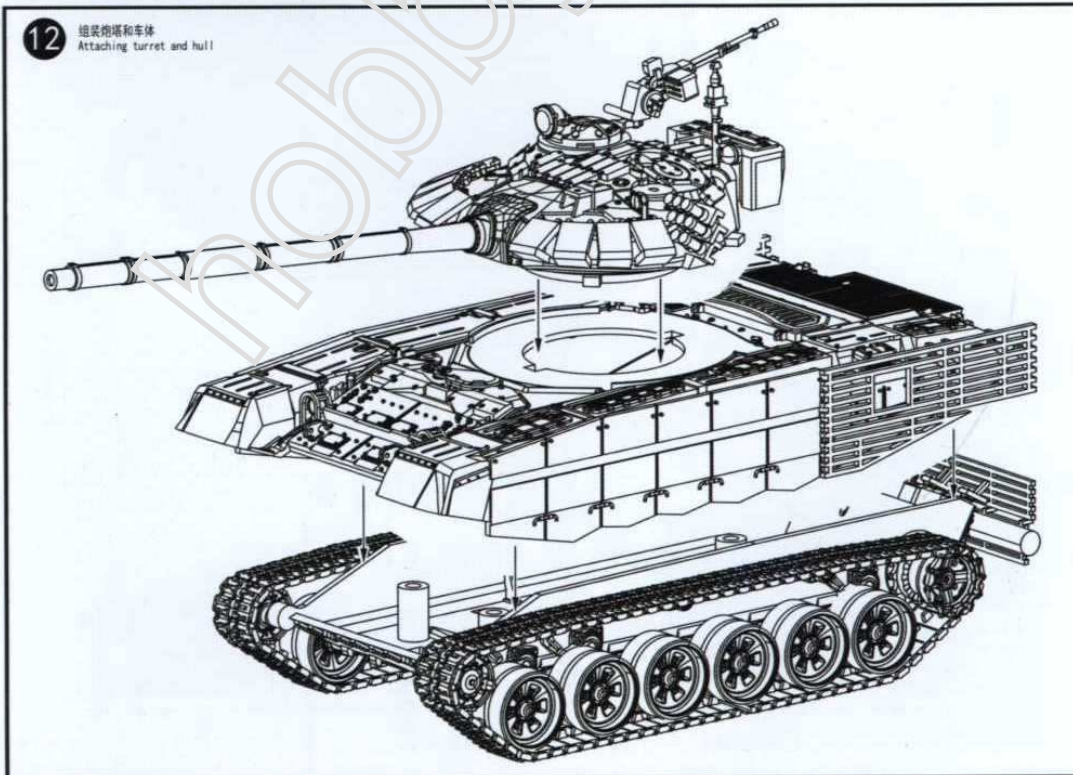

RUSSIAN T-72B3 MAIN BATTLE TANK 2017

MOSCOW VICTORY DAY PARADE

modelcollect

A.MIG 011 RAL 7028 DUNKELGELB AUS '44 DG I

A.MIG 915 Dark Green

A.MIG 008 RAL 7021 DUNKELGRAU

A.MIG 032 Satin Black

A.MIG 037 NEW WOOD

A.MIG 911 GREY SHINE

A.MIG 014 RAL 8012 ROTBRAUN

A.MIG 033 Rubber & Tires

A.MIG 042 OLD RUST

A.MIG 045 Gun Metal

A.MIG 016 RAL 7028 DUNKELGELB AUS '44 DG III

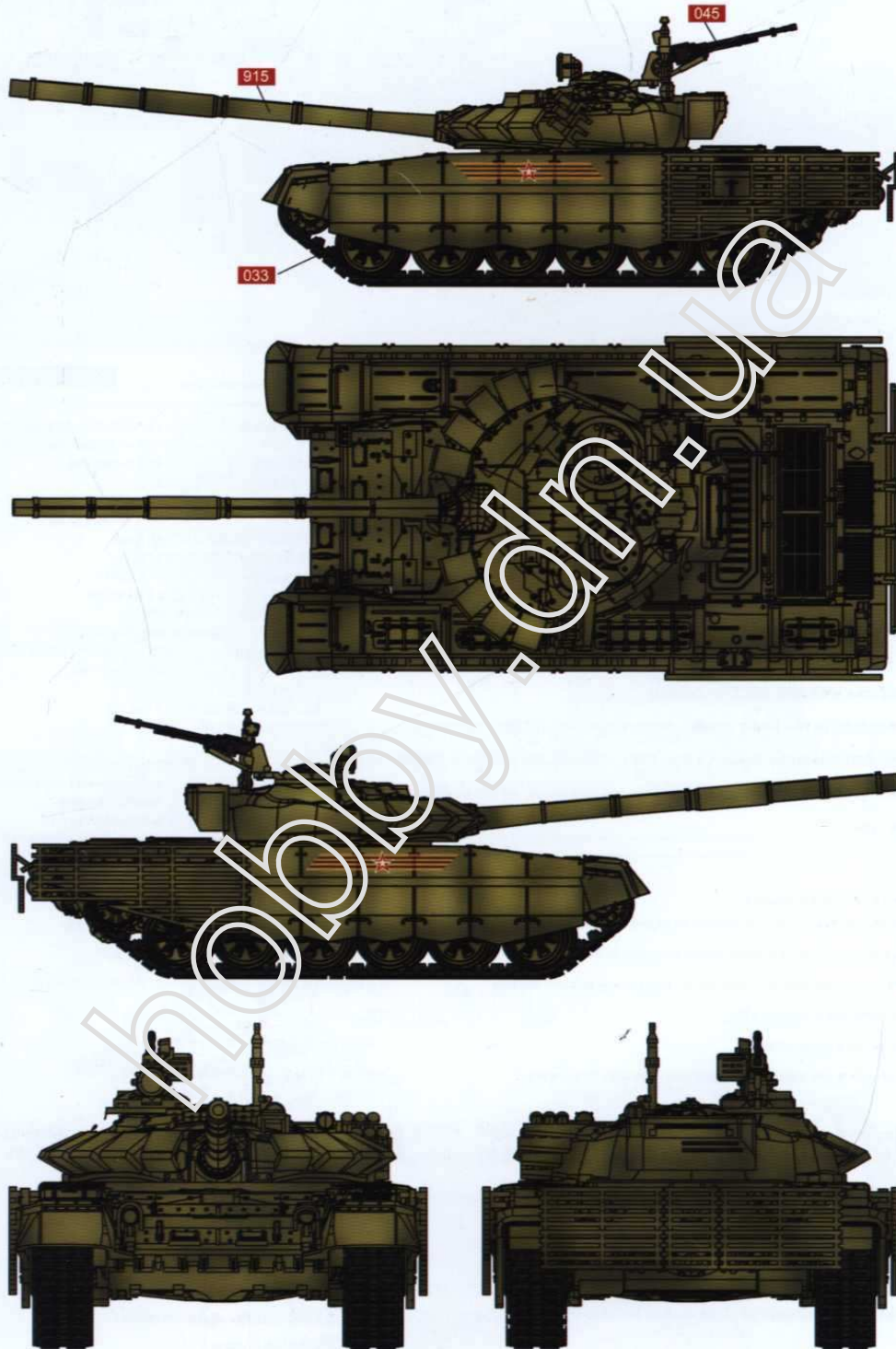

MODELCOLLECT

Color info and profiles by

