

Wolfpack

www.wolfpack-d.com

# RAF Catalina I 'Bismarck'

영국공군 카탈리나 I '비스마르크 추격전'



WP17208

1/72  
Scale

The Consolidated PBV Catalina is an American flying boat, and later an amphibious aircraft of the 1930s and 1940s produced by Consolidated Aircraft. It was one of the most widely used seaplanes of World War II. Catalinas served with every branch of the United States Armed Forces and in the air forces and navies of many other nations.

During World War II, PBVs were used in anti-submarine warfare, patrol bombing, convoy escort, search and rescue missions (especially air-sea rescue), and cargo transport. The PBV was the most numerous aircraft of its kind, and the last military PBVs served until the 1980s.

The Catalina I is the first PBV-5 series ordered by the RAF from the United States, and 109 units were built to be used in maritime patrols, submarine tracking and repulsion missions and rescue. In particular, on May 26, 1941 at 10 am, the RAF's Catalina I (WQ-Z), controlled by US Navy pilot Leonardo B. Smith, discovered and sunk the German battleship Bismarck.

PBY 카탈리나(Consolidated PBV Catalina)는 '컨솔리데이티드 에어크래프트'에서 제작한 비행정으로 제2차 세계대전 중 가장 폭넓게 쓰인 수상 비행기였다. 이 기종은 제2차 세계대전 중 미 해군을 중심으로 미육군항공대(USAAF), 영국과 영연방공군, 소련, 브라질 등 대부분의 연합군에서 폭넓게 사용되었다. 제2차 세계 대전 동안, PBY는 대잠수함전, 조계 폭격, 호송, 탐색 구조 임무 (특히 해상 구조), 화물운송 등에 사용되었다. PBY는 가장 다양한 동류의 기종이 존재했고, 1980년대까지는 민간과 군사용으로 사용되었다. 첫 비행으로부터 80년 가까이 이르는 2014년에도 카탈리나는 비행이 가능한 기체가 다수 남아있다.

Catalina I은 영국이 미국에 주문한 첫 번째 PBV-5 시리즈로, 109대가 제작되어 해상조계, 잠수함 추적 및 격퇴임무와 구조 등에 사용되었다. 특히 1941년 5월 말의 독일전함 비스마르크 추격전에서 활약하여, 5월 26일 오전 10시 미 해군 파일럿 레오나르도 B. 스미스가 조종하는 영국공군의 Catalina I (WQ-Z)이 독일전함 비스마르크를 발견, 이를 격침시키는데 큰 공헌을 했다.



Work by Honghwan Jang

Contains one unassembled model kit only.  
No Paint and Cement in box.  
Kit suitable for Age 14 to Adult.

조립되지 않은 키트가 들어있습니다.  
접착제와 도료는 들어있지 않습니다.  
15세 이상 판매용

Wolfpack-Design Co. Ltd.

F2, 352, Gwangdoek 4-ro, Sangroku, Ansan-si, Gyeongido,  
15489, Republic of Korea

울프팩디자인  
경기도 안산시 상록구 광덕4로 352, 2층  
우 : 15489

Printed in Korea

**1** Cockpit  
(조종석)

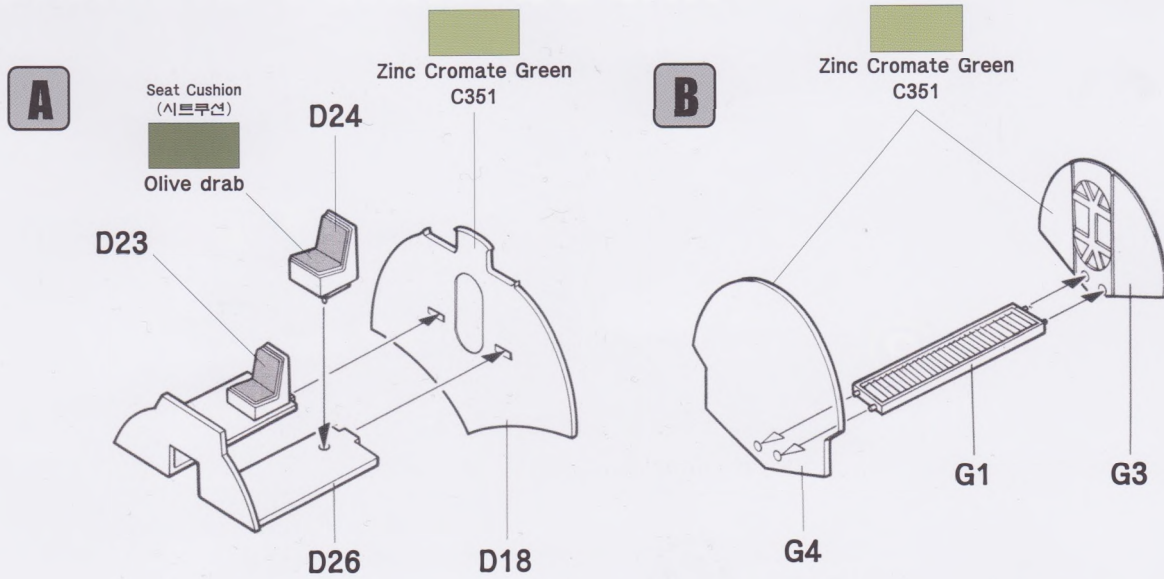

\*Color number : GSI Creos Mr. Color.

**2** Fuselage Assembly  
(동체조립)

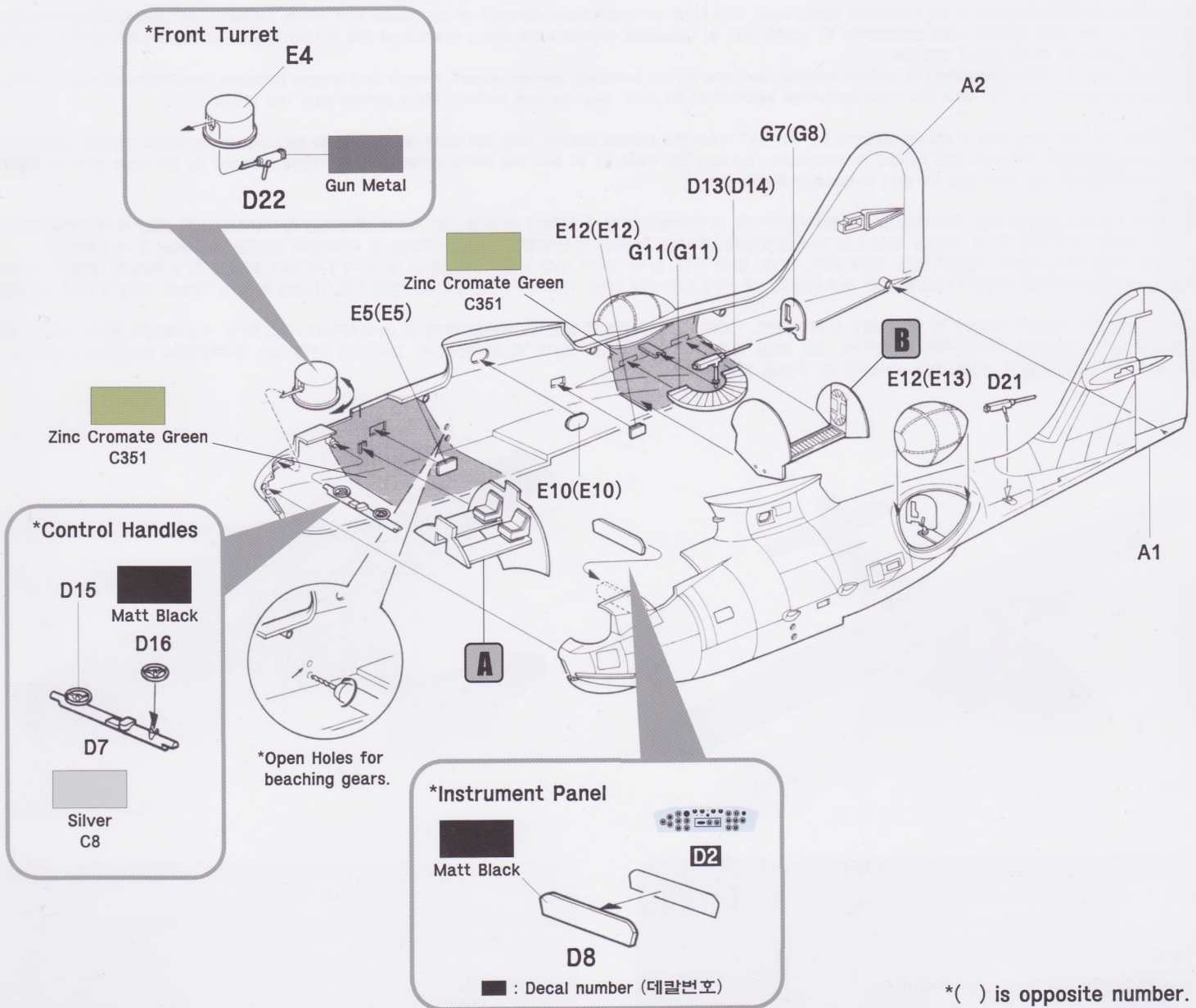

\*( ) is opposite number.

**3** Main Wing & Floats Assembly  
(주익과 플로트 조립)

**L** **R**

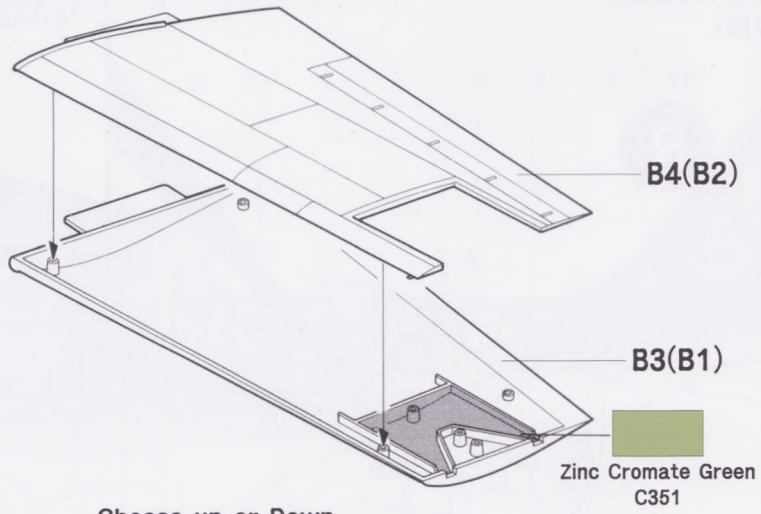

Choose up or Down position for floats.

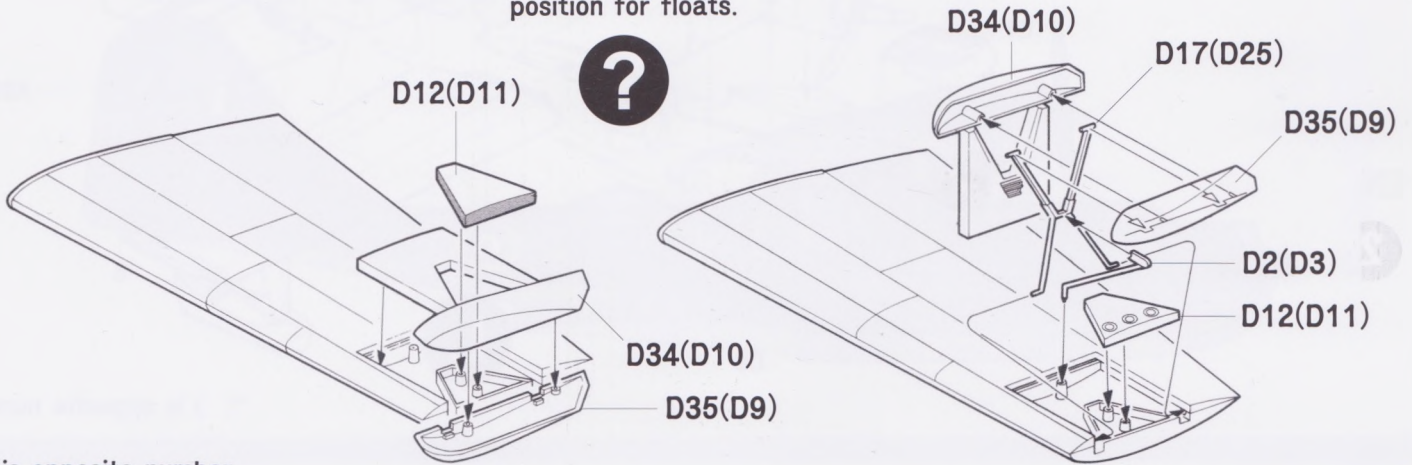

\*( ) is opposite number.

**4** Main Wing & Engine Assembly  
(주익과 엔진 조립)

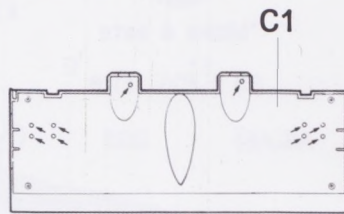

\*Open Holes in C1 before assembly

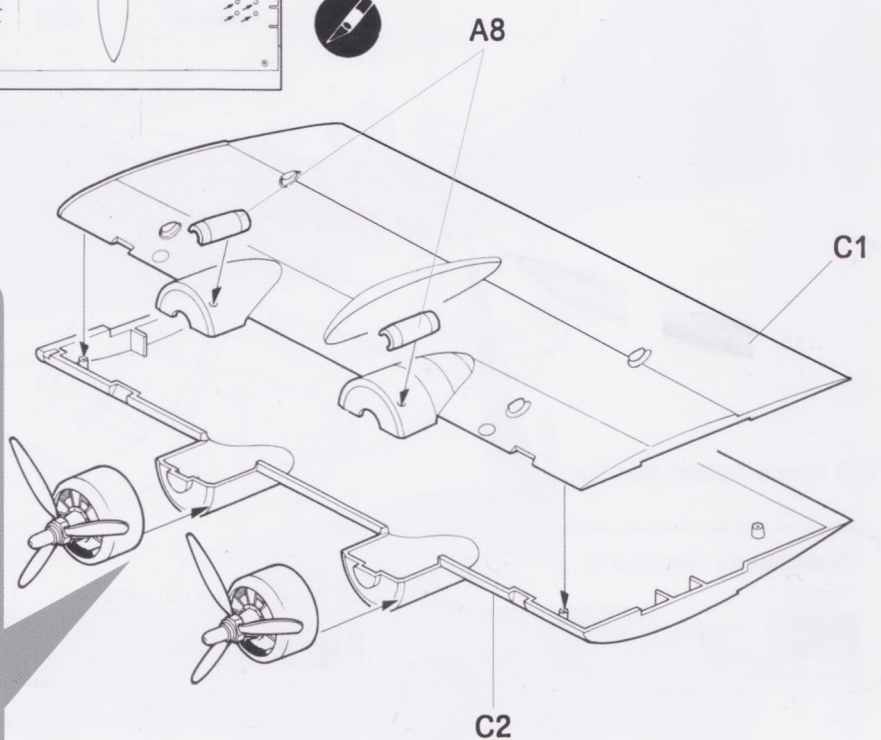

\*Engine nacelle & Propeller

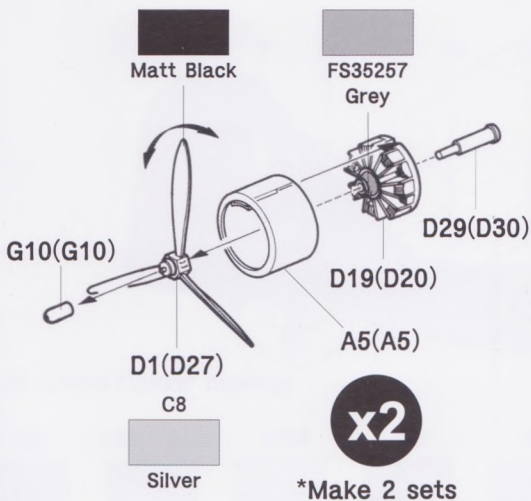

\*Make 2 sets

\*( ) is opposite number.

**5** Fuselage & Wing Assembly  
(동체와 날개결합)

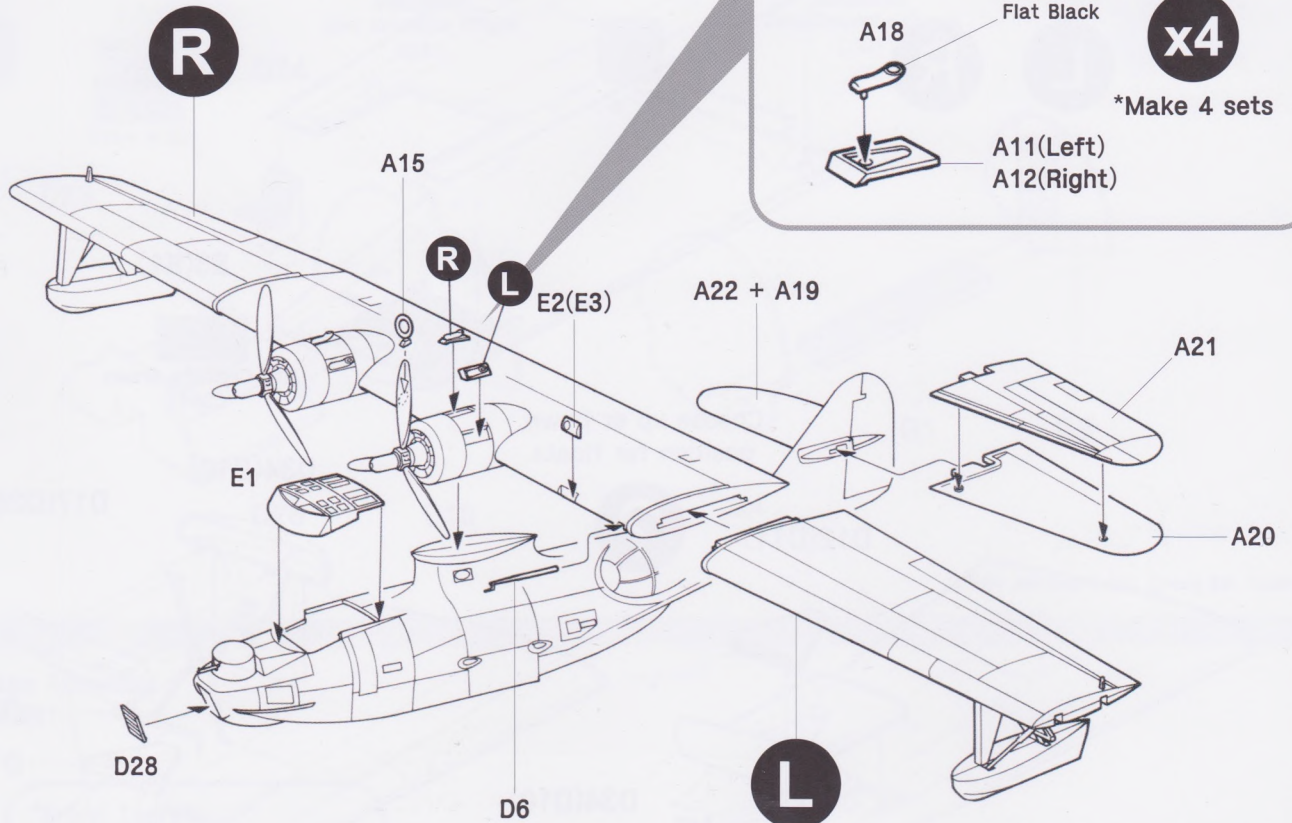

\*Exhaust mufflers

C33

Flat Black

**x4**

\*Make 4 sets

A18

A11(Left)  
A12(Right)

\*( ) is opposite number.

**6** Beaching gears & Armaments  
(주기용 기어와 무장)

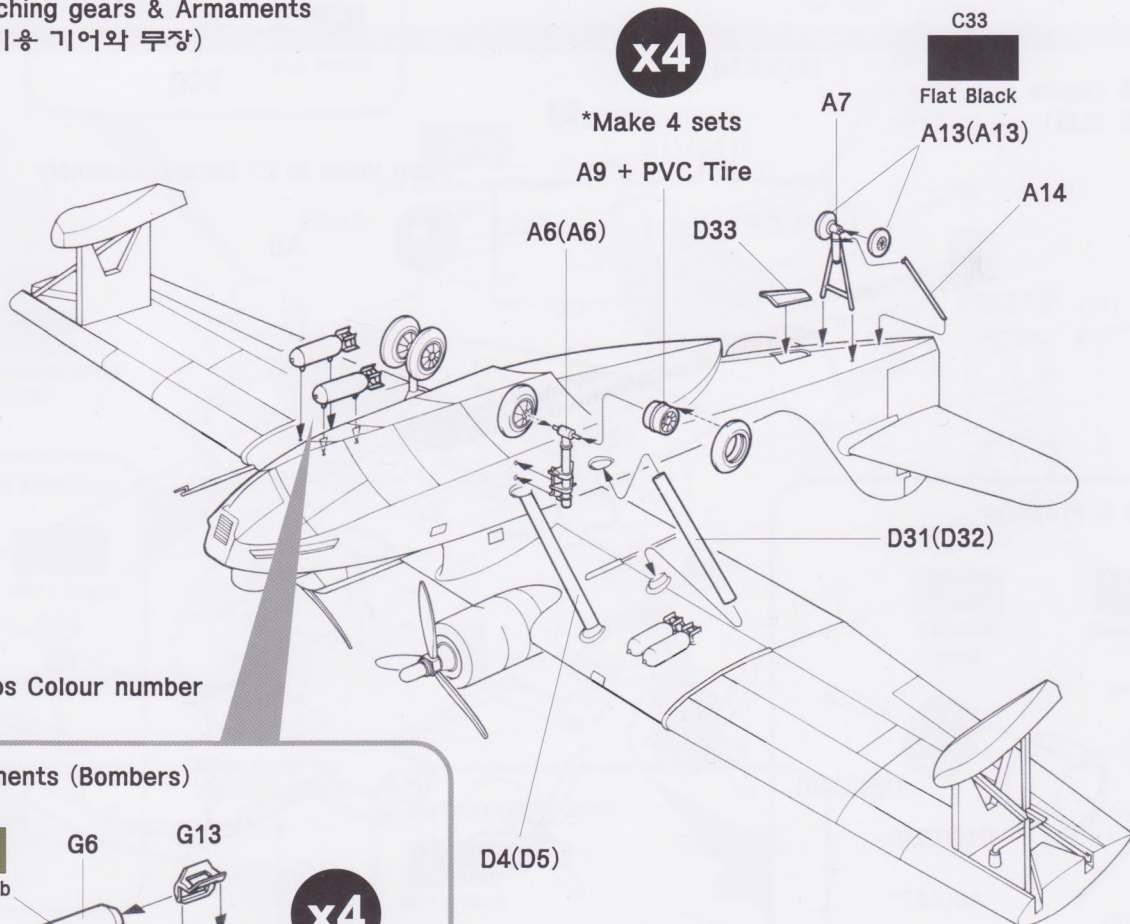

**x4**

\*Make 4 sets

C33

Flat Black

A13(A13)

A9 + PVC Tire

A14

A6(A6)

D33

D31(D32)

\*GSI Creos Colour number

\*Armaments (Bombers)

C304

Olive drab

G6

G13



G12

**x4**

\*Make 4 sets

**1** Catalina I (PBY-5) AH545 WQ Z, flown by US Navy pilot Leonard B. 'Tuck' Smith, 209 Squadron RAF, Lough Erne, Northern Ireland, May 1941. This Catalina I spotted and tracked the German Battleship Bismarck 26, May 1941.

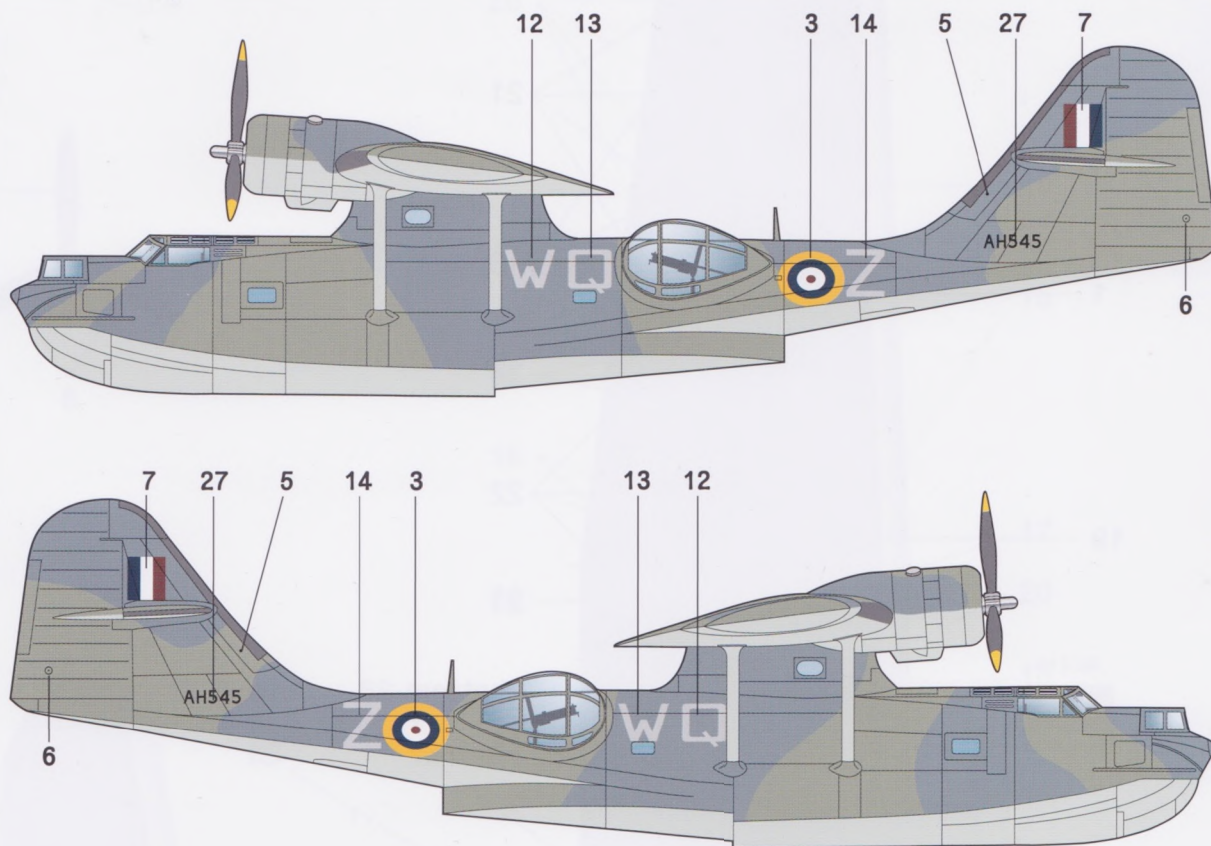

**2** Catalina I (PBY-5) Z2147 AX L, 202 Squadron RAF, Based at Gibraltar, the Mediterranean Sea, 1941. This Catalina I (Z2147) was credited with nine successful attacks on enemy submarines.

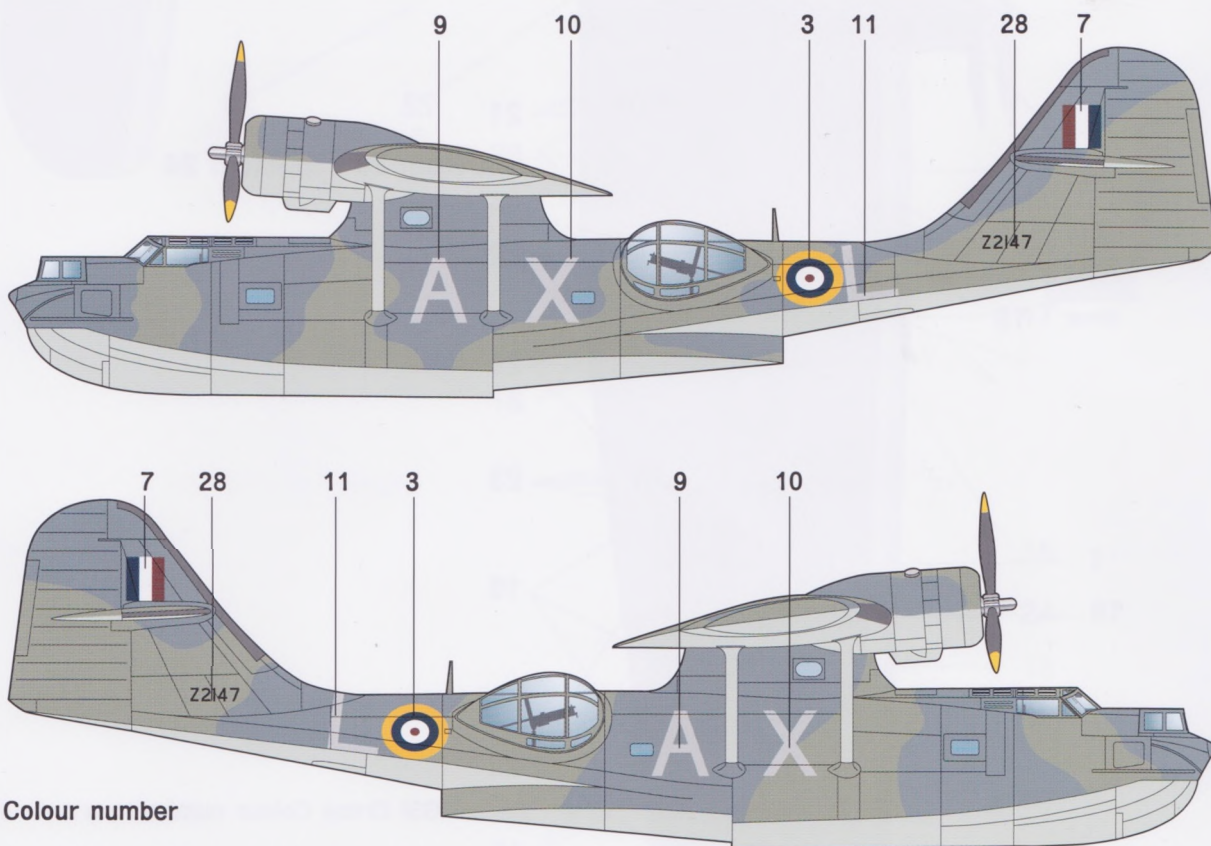

\*GSI Creos Colour number

C333	C38 + C40	C368	C33	C8
Extra Dark Sea Grey	Dark Slate Grey	Beige Green	Flat Black	Silver

**! Basic Stencils (Top)**

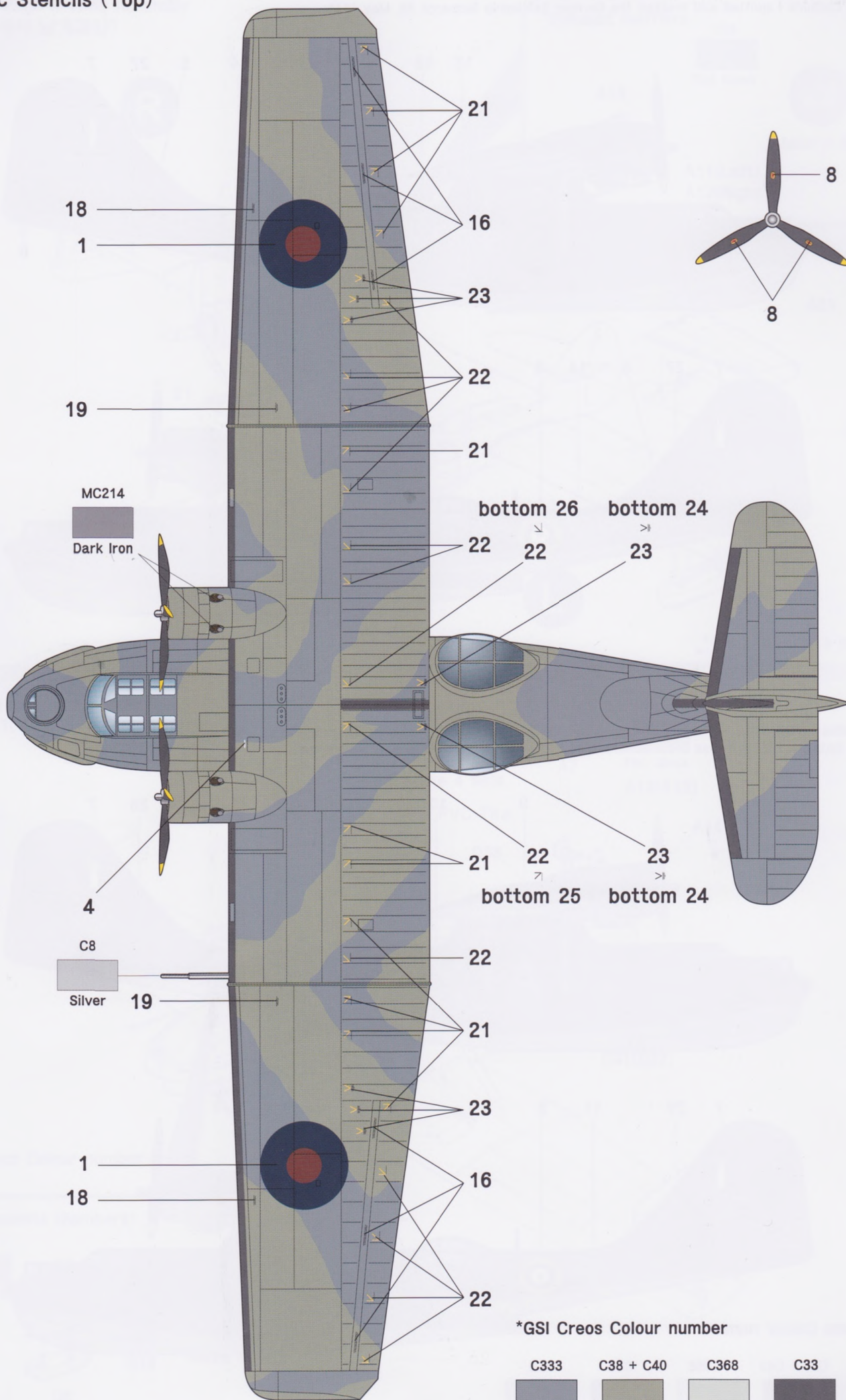

18  
1

19

MC214  
Dark Iron

C8  
Silver

1  
18

21  
16  
23  
22  
21  
22  
22  
22  
21  
22  
22  
21  
23  
23  
22  
21  
22  
23  
23  
22  
21  
22

bottom 26  
bottom 24  
22  
23  
22  
23  
bottom 25  
bottom 24

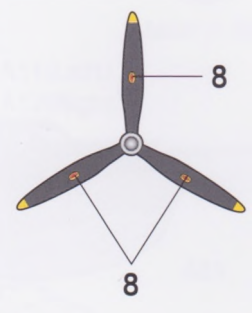

\*GSI Creos Colour number

C333	C38 + C40	C368	C33	C8
Extra Dark Sea Grey	Dark Slate Grey	Beige Green	Flat Black	Silver

**! Basic Stencils (Bottom)**

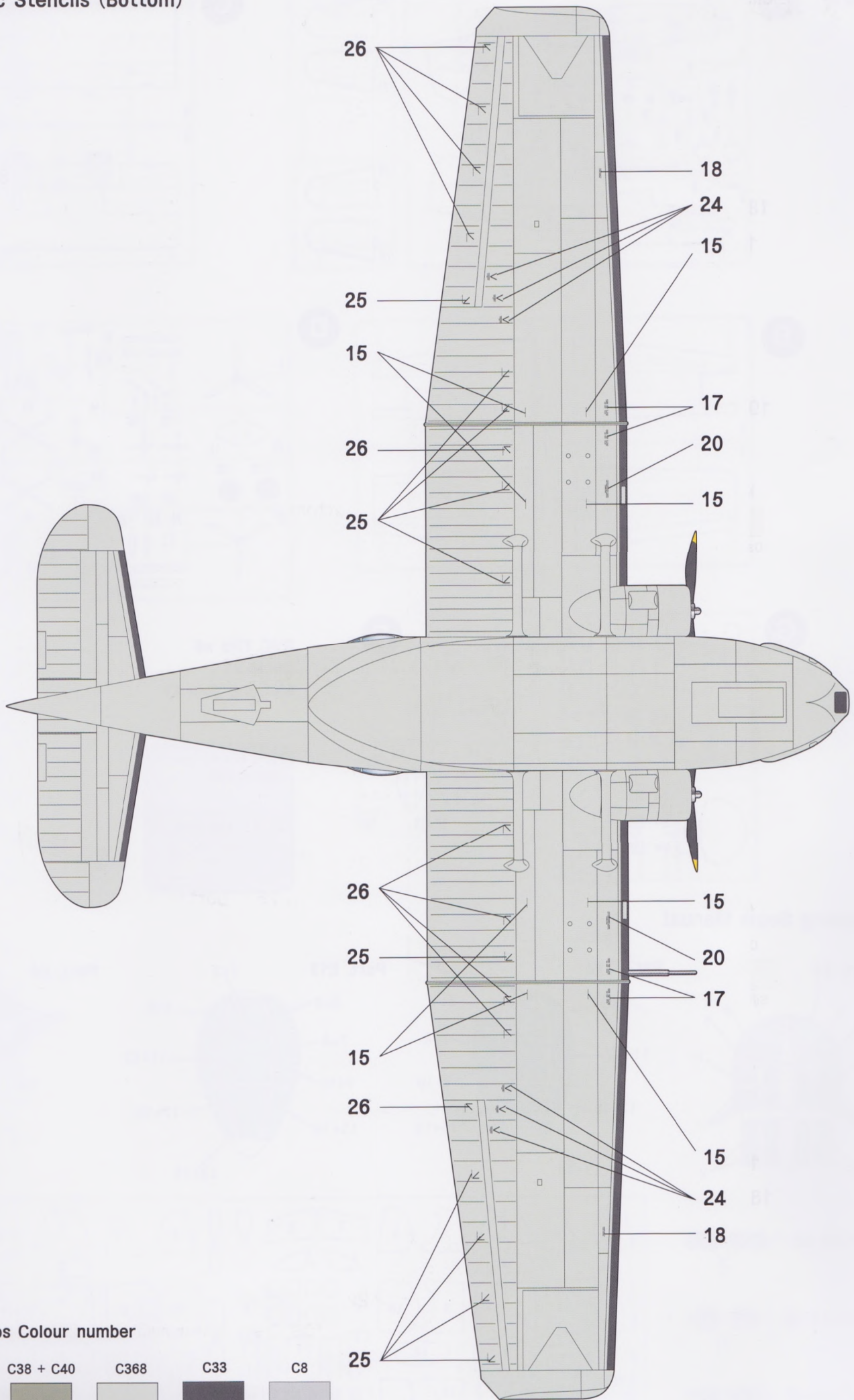

\*GSI Creos Colour number

C333	C38 + C40	C368	C33	C8
Extra Dark Sea Grey	Dark Slate Grey	Beige Green	Flat Black	Silver

**! Parts**

**A**

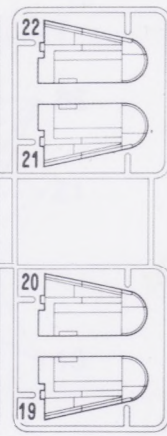
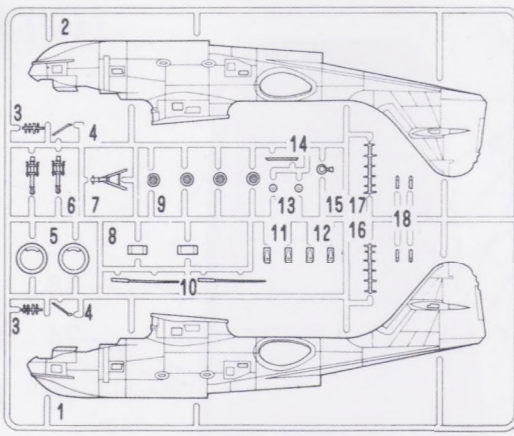

**C**

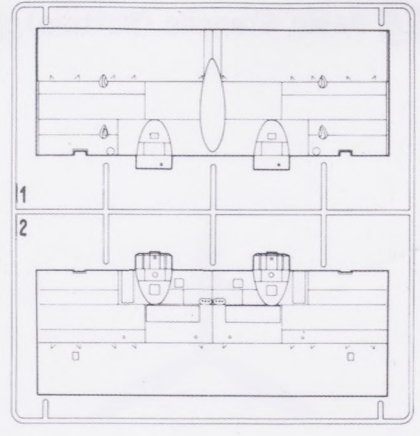

**B**

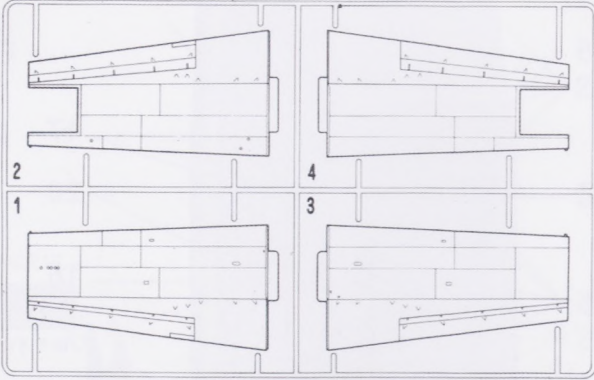

**D**

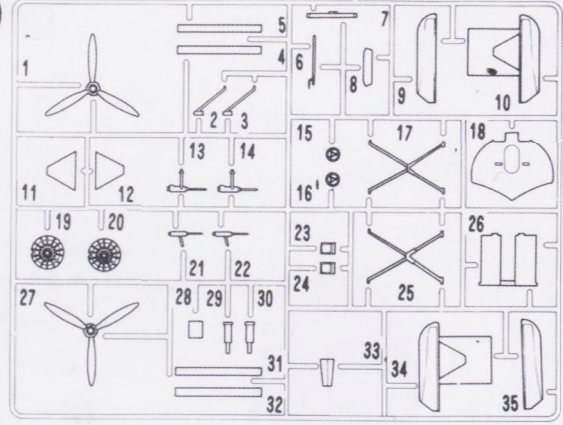

**G**

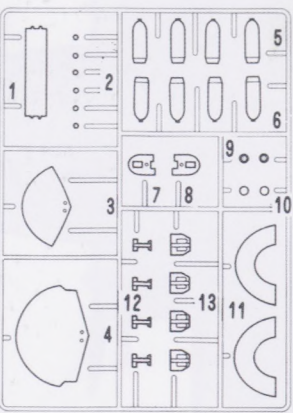

**E**

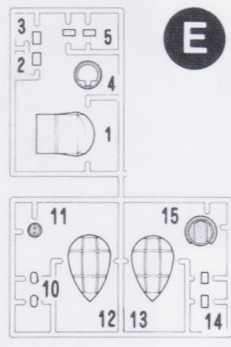

PVC Tire x4  
Decal x1  
Masking seal x1

Parts not for use.  
(불필요부품)  
  
A3, A4, A10, A16,  
A17, E15

**! Masking Seals Manual**

