



#1132

INTRO

The Macchi C.202 Folgore (Italian "thunderbolt") was a World War II fighter aircraft designed by Mario Castoldi, built by Macchi Aeronautica and operated mainly by the Regia Aeronautica.

The decision of the Italian military authorities to adopt radial engines meant that, during the second half of the 1930s, the Italian aeronautical industry failed to develop more powerful engines based on streamlined liquid-cooled designs. This forced Macchi Aeronautica to rely on the ageing Fiat A.74 radial engine for its C.200 fighter. By 1941, the C.200, armed with two 12.7 mm (.50 in) machine guns and with a maximum speed of 504 km/h (315 mph), was obsolete. In July 1939, the most powerful reliable Italian inline engine was the 715 kW (960 hp) Isotta Fraschini Asso XI R.C.40, which was designed in 1936. In November 1939, Alfa Romeo acquired the license to produce the DB 601Aa as the Alfa-Romeo RA.1000 R.C.41-I Monsona, which was to be used in the production of C.202s. Macchi chief of design Mario Castoldi began to work on mating the Macchi C.200 wings, undercarriage, vertical and horizontal tail units with a new fuselage incorporating the imported DB 601Aa. Design of the new fighter began in January 1940 and, less than seven months later, on 10 August 1940, the sole prototype, MM.445, made its first flight, two months after Italy's entry into World War II. Test results showed that Italy had caught up with Britain and Germany in the field of fighter airplanes. The prototype was flown to the Regia Aeronautica's main test airfield at Guidonia, where it met with an enthusiastic response from test pilots. A speed of 603 km/h (375 mph) was recorded, with 5,486 m (18,000 ft) being reached in six minutes and little of the good maneuverability of the C.200 was lost. Due to the flight test reports, the C.202 was immediately ordered into production with the first examples appearing in May 1941. Breda in Milan was also chosen to build the C.202 and eventually built the majority of the type. SAI-Ambrosini was another sub-contractor, building some 100 C.202s. The first units selected to be equipped with the C.202 Series I were the 17° and 6° Gruppi, from 1° Stormo, based at the airfield of Campoformido, near Udine, and the 9° Gruppo of 4° Stormo, based in Gorizia. Their pilots start to train on the new fighter in May–June 1941, at Lonate Pozzolo (Varese), the airfield of the Macchi. The Folgore first saw service during the Siege of Malta on 29 or 30 September 1941; this first mission was intercepting British Hurricanes over Sicily. From early October 1941 the Italian units commenced extensive operations over Malta, on the besieged island, the new Macchi fighter was not only used for fighter operations, but also for ground attacks and reconnaissance missions. The presence of the Folgore in Maltese skies was to last only until the end of November, when most of the unit was transferred to the deteriorating North Africa front. On 29 July, the three first operational C.202s of 4° Stormo, 97^a Squadriglia, landed at Merna airport in north Africa. On 26 November 1941, during Operation Crusader, 19 Macchis of 9° Gruppo, 4° Stormo were sent to Africa, and by the end of the month the whole 1° Stormo was in Libya, both units taking part in the last stages of the British offensive that led to the raising of the siege of Tobruk, and the retreat of Italian and German troops in Cyrenaica in December. During its initial combats over the Western Desert, the Folgore was quite a surprise to British pilots and it remained a respected adversary. During 1942, Bf 109F/Gs and Macchi C.202s fought Allied air forces in the skies of North Africa. At the end of the year, the growing strength of the Allied forces was overwhelming and after the defeat in the skies over Malta as well as El-Alamein the last operational Axis units lost their air superiority in the Mediterranean. The Germans and the Italians succeeded in establishing a bridgehead in Tunisia, and later in December the Regia Aeronautica transferred four fighter squadrons there. In early 1943, Regia Aeronautica had only 54 serviceable C.202 in 12 squadrons. The Macchis continued fighting while retreating to Tunisia and then in the defence of Sicily, Sardinia and Italy against an increasingly stronger opponent. In August 1942, at the beginning of the German offensive in Russia was 21° Gruppo Autonomo C.T. composed of 356^a, 382^a, 361^a and 386^a Squadriglia deployed to the Stalino, Lughansk, Kantemirovka and Millerovo airfields, fighting against the Red Army positions on the east Don river during October–November 1942. The fighters operated in adverse climate conditions (40° to 45° below zero and heavy snow storms) while under heavy Russian fighter-bomber harassment. Only a total of 17 missions were flown with Folgore on the Eastern Front during a four-month period. After the abandonment of advanced airfields between December 1942 – January 1943 at Voroshilovgrad, Stalino and Tscerkow, the Italian air units operated in defensive actions against a more potent Soviet air offensive. In March 1943, the Corpo Aereo Italiano was detached to Odessa airbase joining and the last effective operation of Corpo Aereo Italiano in Russia occurred on 17 January 1943. At the Armistice, there were only 186 Folgore, with 100 aircraft still serviceable. Several C.202s also served with the Italian Co-Belligerent Air Force, and some were transformed into C.205s or C.202/205 with the Veltro's engine. Others served as trainers in the Aeronautica Nazionale Repubblicana (National Republican Air Force) of the Italian Social Republic and the Luftwaffe. Switzerland ordered 20 C.202s, but none were delivered, because at that time (12 May 1943), Italy no longer had the capability to export these types of aircraft. 12 C.202s and probably another 12 were delivered to the Croatian Air Force Legion for operational use against the RAF and USAAF over Croatia in mid-1944, all ex-LW fighters. The Macchi C.202 was flown by almost all the most successful Italian aces, considered to be one of the best wartime fighters to serve in large numbers with the Regia Aeronautica, the Folgore operated on all fronts in which Italy was involved.



Carefully read instruction sheet before assembling. When you use glue or paint, do not use near open flame and use in well ventilated room. Keep out of reach of small children. Children must not be allowed to suck any part, or pull vinyl bag over the head.



Před započítím stavby si pečlivě prostudujte stavební návod. Při používání barev a lepidla pracujte v dobře větrané místnosti. Lepidla ani barvy nepoužívejte v blízkosti otevřeného ohně. Model není určen malým dětem, mohlo by dojít k požití drobných dílů.

INSTRUCTION SIGNS * INSTR. SYMBOL * INSTRUKTION SINNBILDEN * SYMBOLES * 記号の説明



OPTIONAL
VOLBA



BEND
OHNOUT



OPEN HOLE
VYVRTAT OTVOR



SYMMETRICAL ASSEMBLY
SYMETRICKÁ MONTÁŽ



REMOVE
ODŘÍZNOUT



REVERSE SIDE
OTOČIT



APPLY EDUARD MASK
AND PAINT
POUŽÍT EDUARD MASK
NABARVIT

PARTS



DÍLY



TEILE



PIÈCES



部品

PLASTIC PARTS

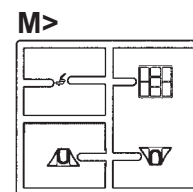
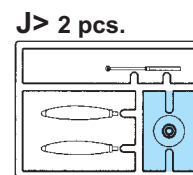
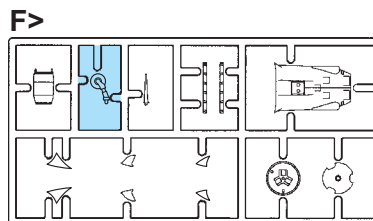
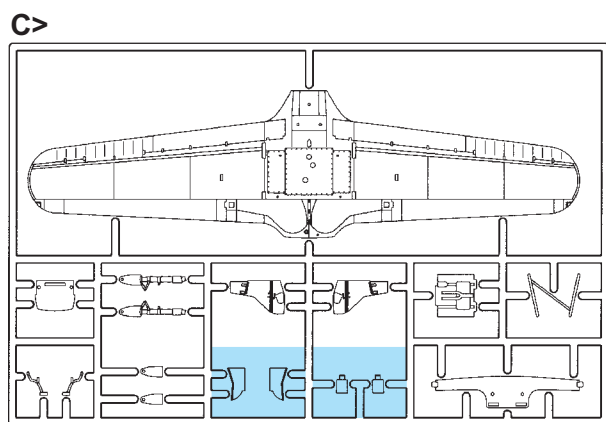
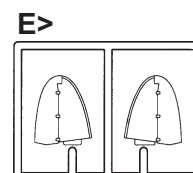
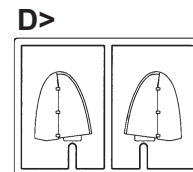
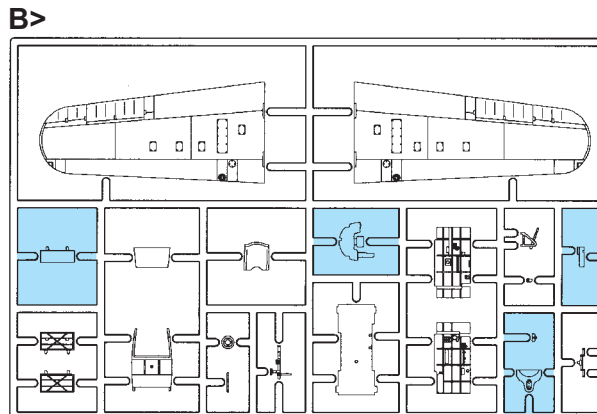
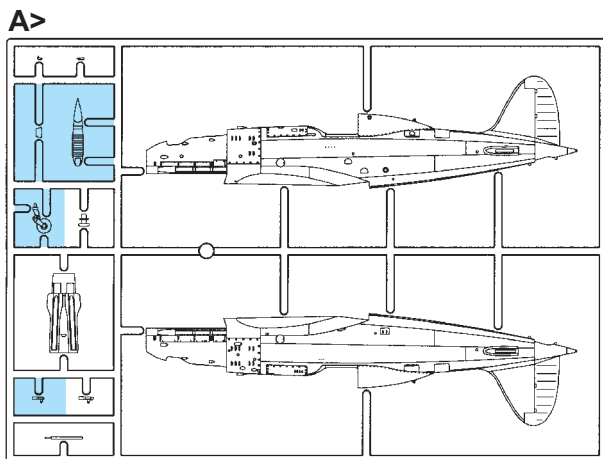
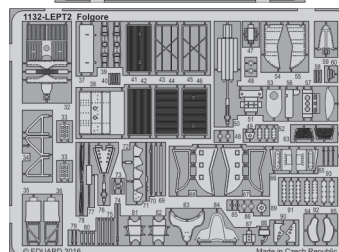
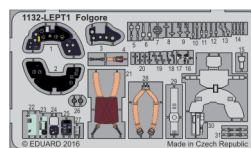
PE - PHOTO ETCHED
DETAIL PARTS

eduard
MASK

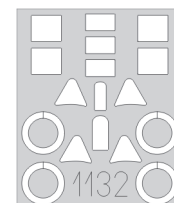

FILM



1132

Folгоре

eduard
BRASSIN RP - RESIN PARTS

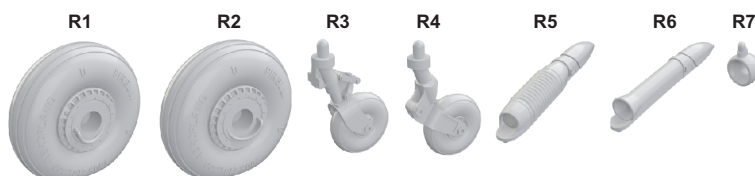

COLOURS



BARVY



FARBEN



PEINTURE



色

GSI Creos (GUNZE)		
AQUEOUS	Mr.COLOR	
H 4	C4	YELLOW
H 8	C8	SILVER
H 11	C62	FLAT WHITE
H 12	C33	FLAT BLACK
H 37	C43	WOOD BROWN
H 47	C41	RED BROWN
H 65	C18	BLACK GREEN
H 76	C61	BURNT IRON
H 77	C137	TIRE BLACK
H 79	C39	SANDY YELLOW

AQUEOUS	Mr.COLOR	
H 90	C47	CLEAR RED
H 94	C138	CLEAR GREEN
H 303	C303	GREEN
H 310	C310	BROWN
H 312	C312	LIGHT GREEN
H 317	C317	GRAY
H 324	C324	LIGHT GRAY
H 327	C327	RED
Mr.COLOR SUPER METALLIC		
SM06		CHROME SILVER

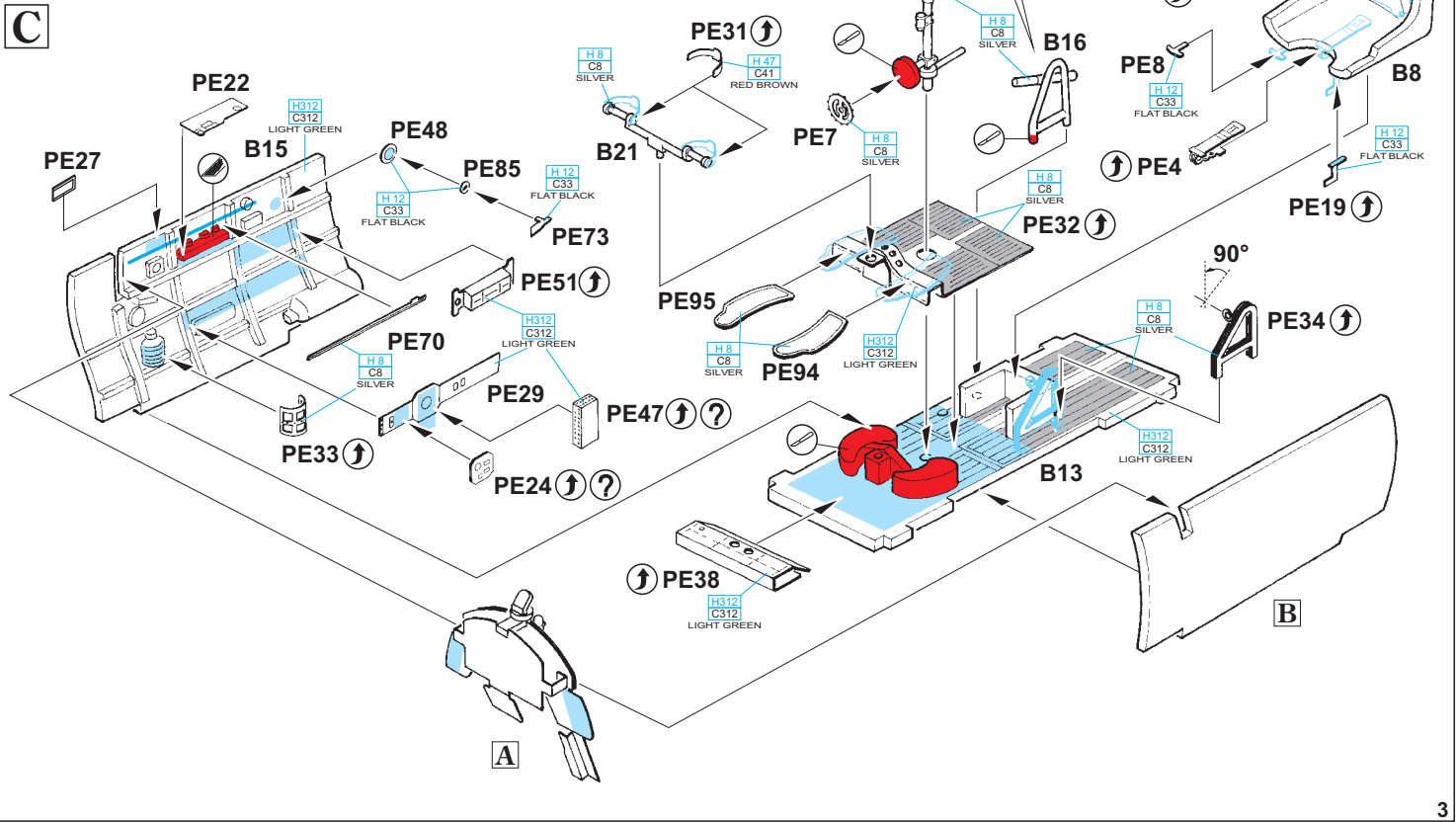
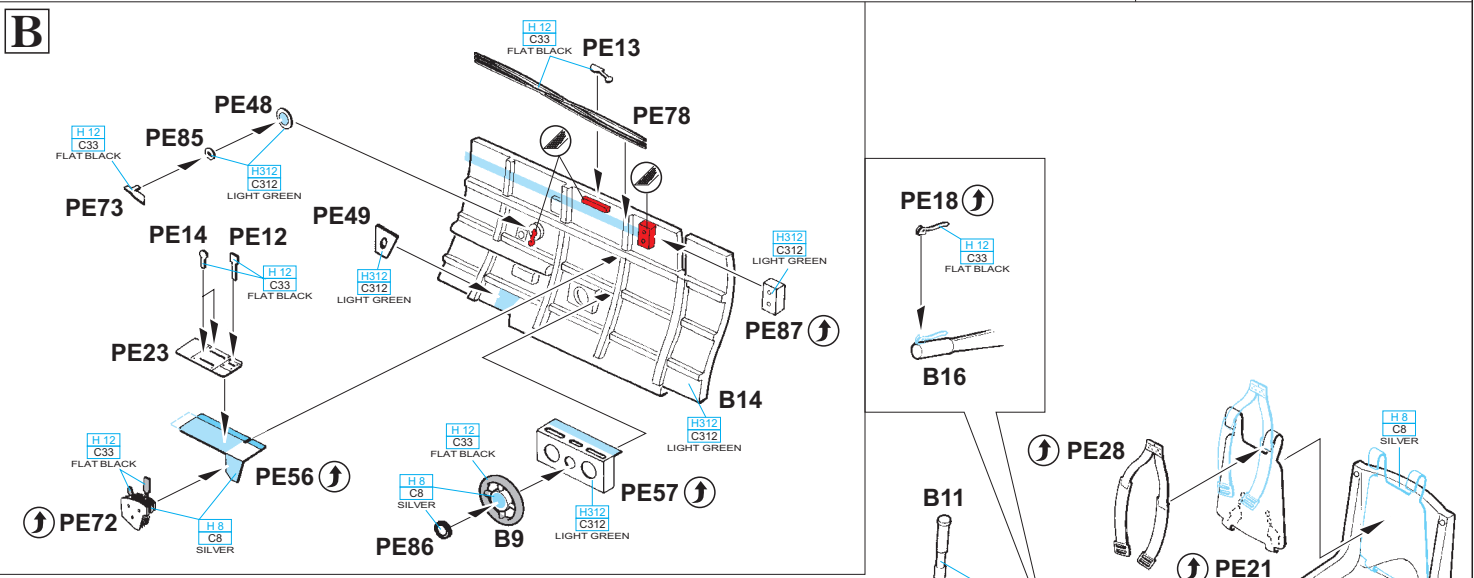
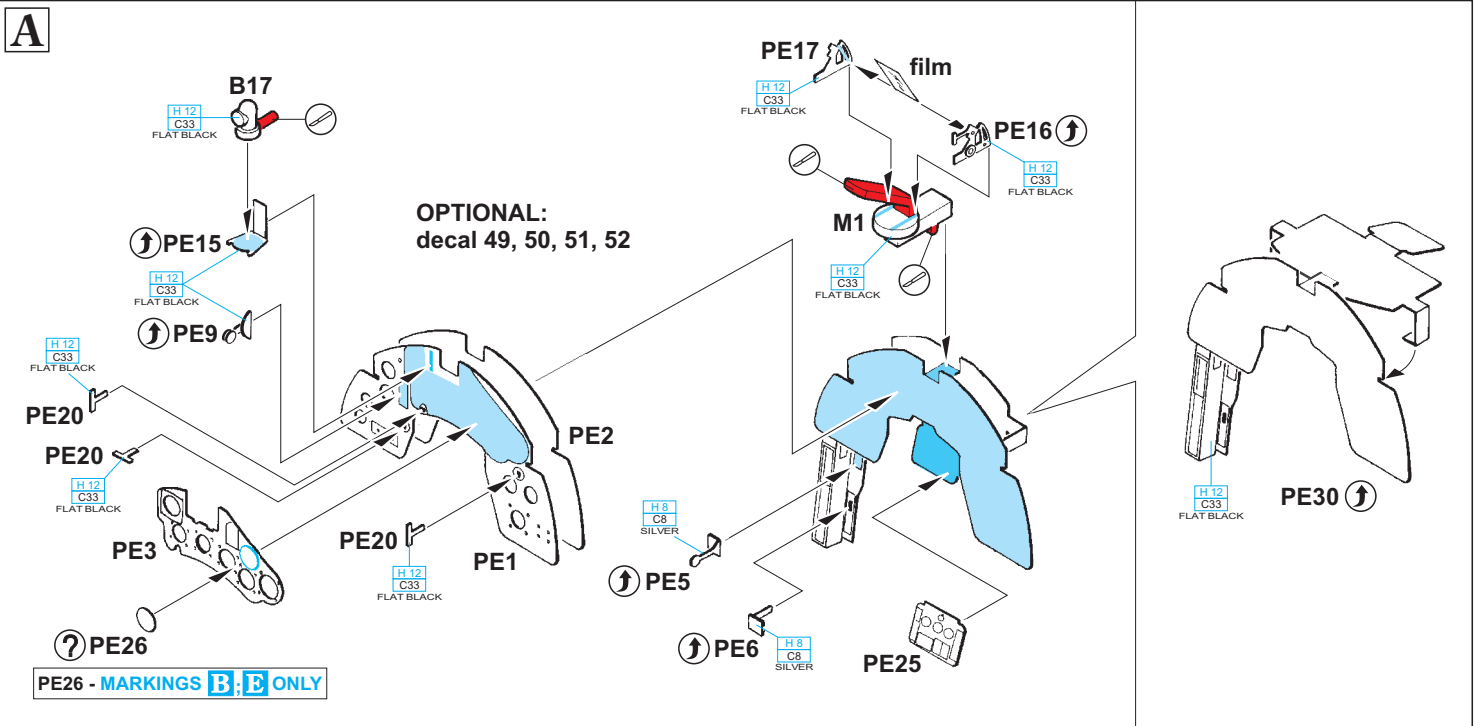

E2 - MARKINGS B; E ONLY D2 ? E2

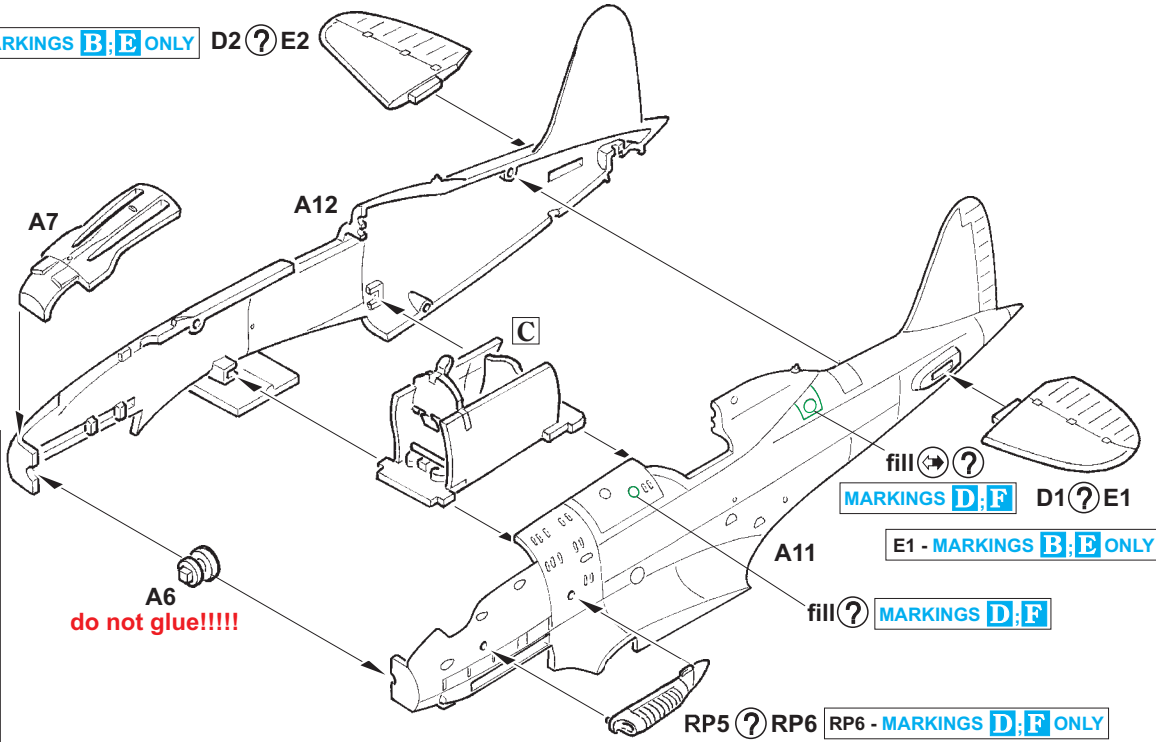

MARKING F

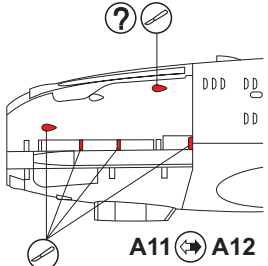

ALL MARKINGS

fill ? MARKINGS D; F D1 ? E1

E1 - MARKINGS B; E ONLY

fill ? MARKINGS D; F

RP5 ? RP6 RP6 - MARKINGS D; F ONLY

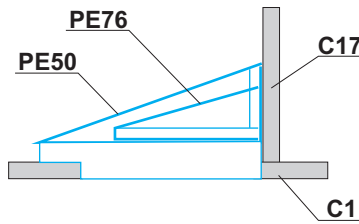
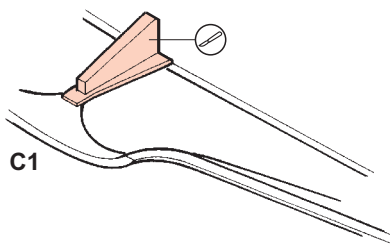

D

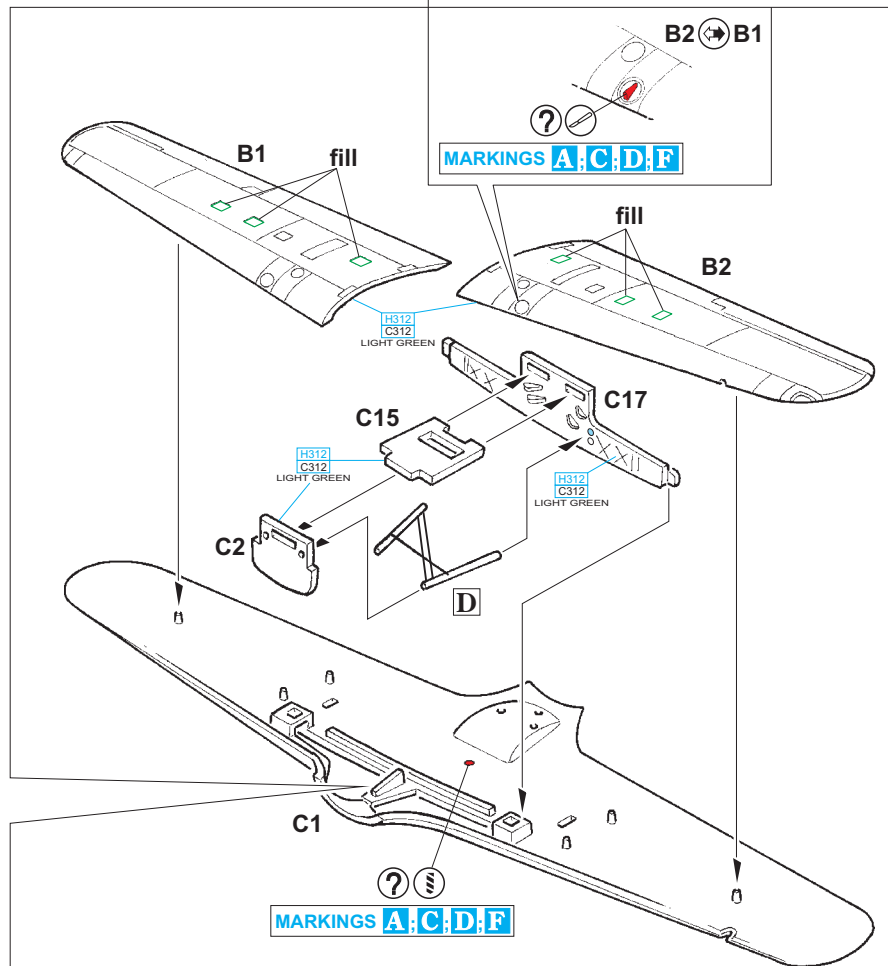
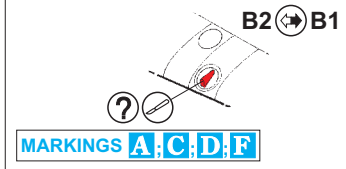
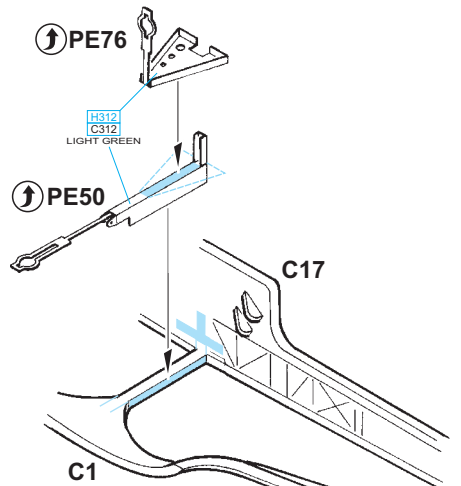
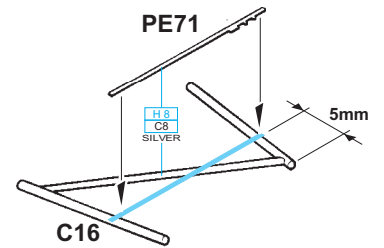

MARKINGS A; C; D; F

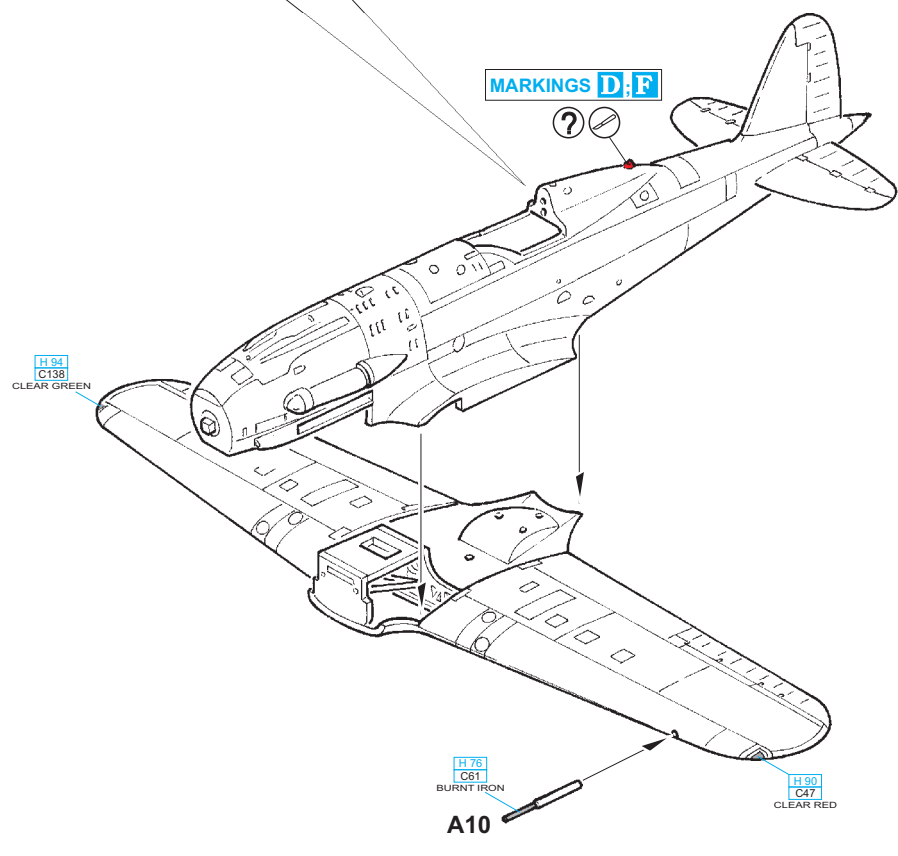
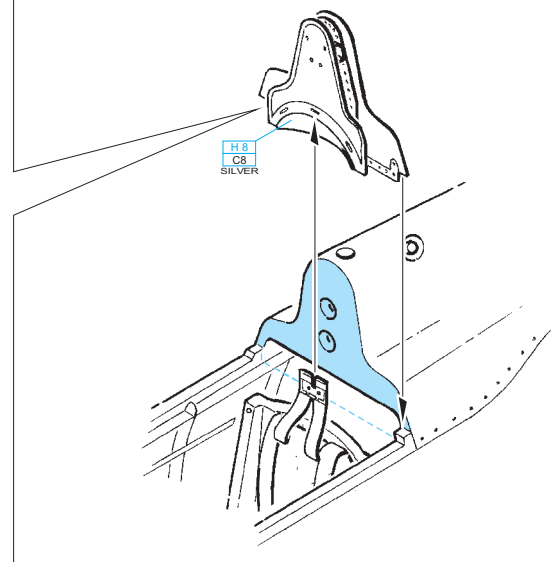
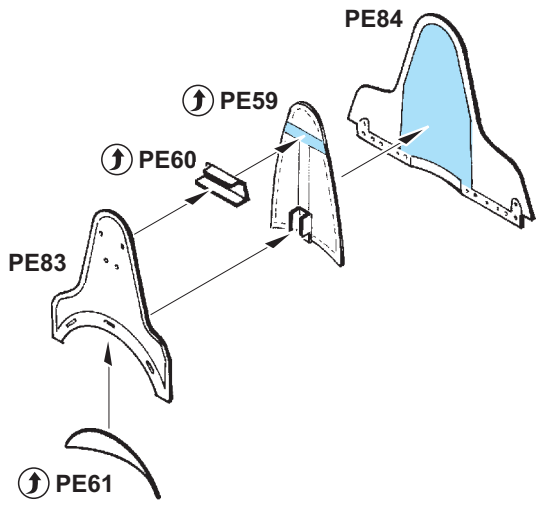

L ↔ **R**

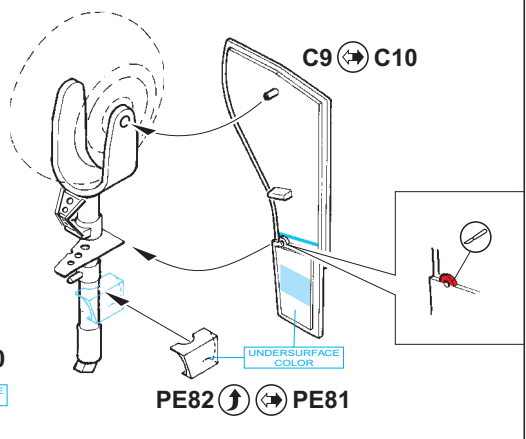
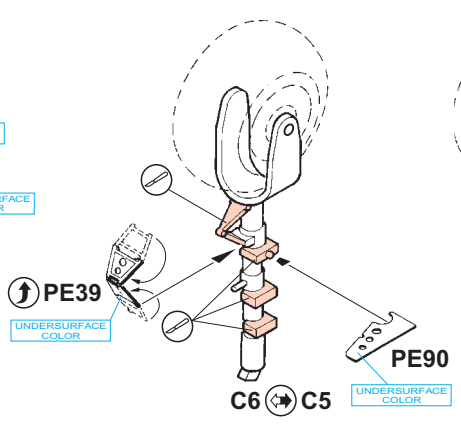
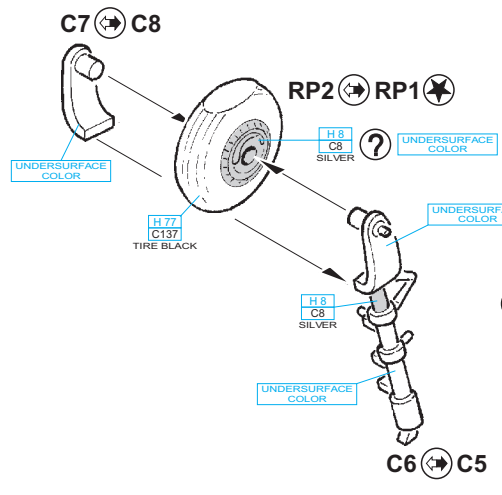

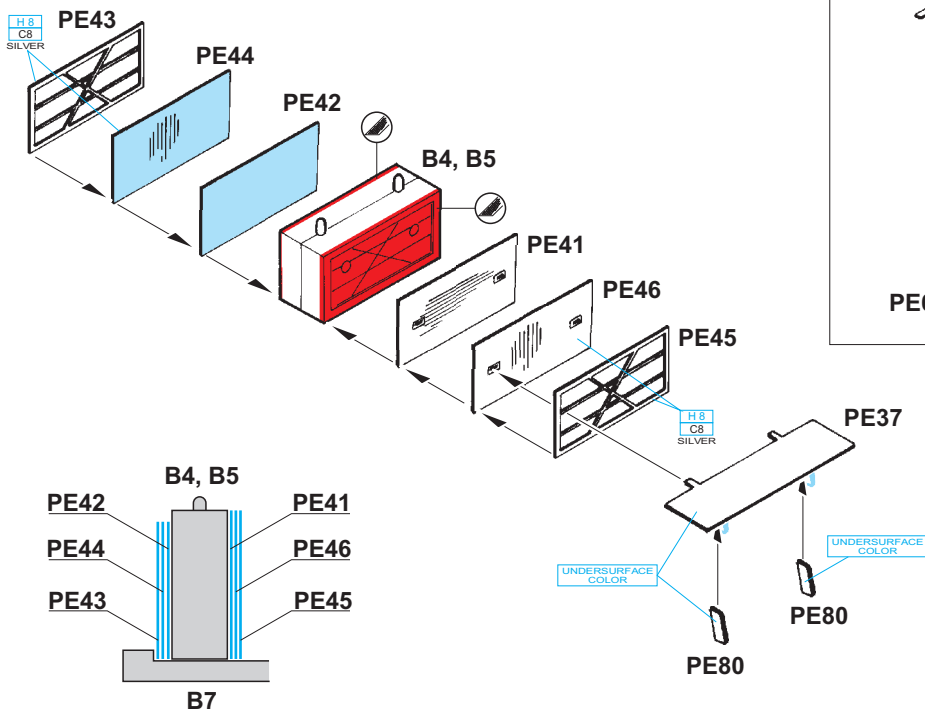
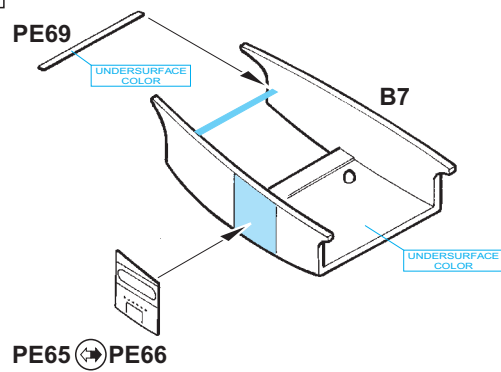
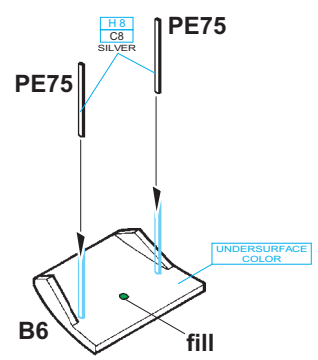
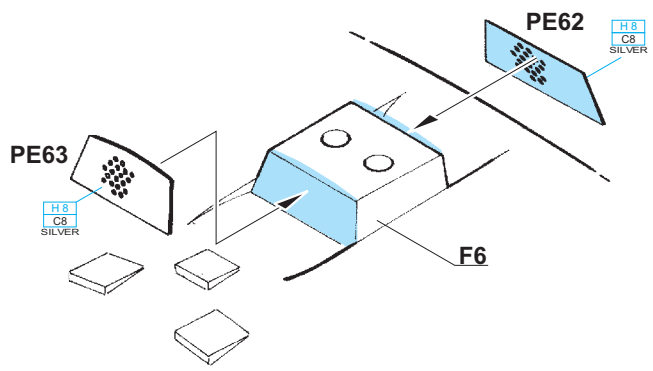
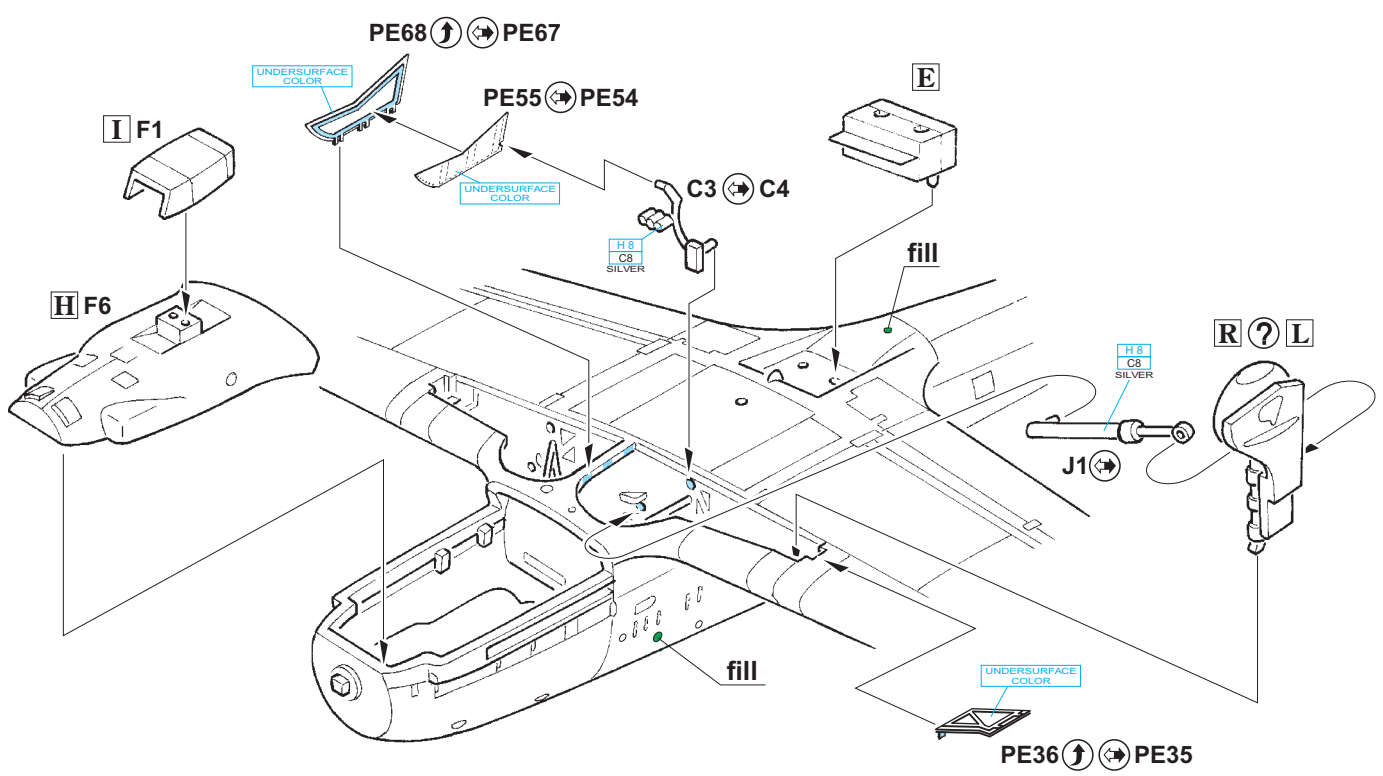
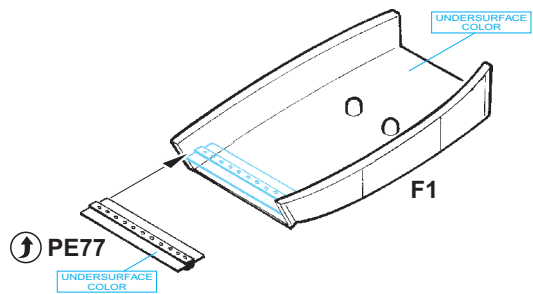
E**F****G****H****I**

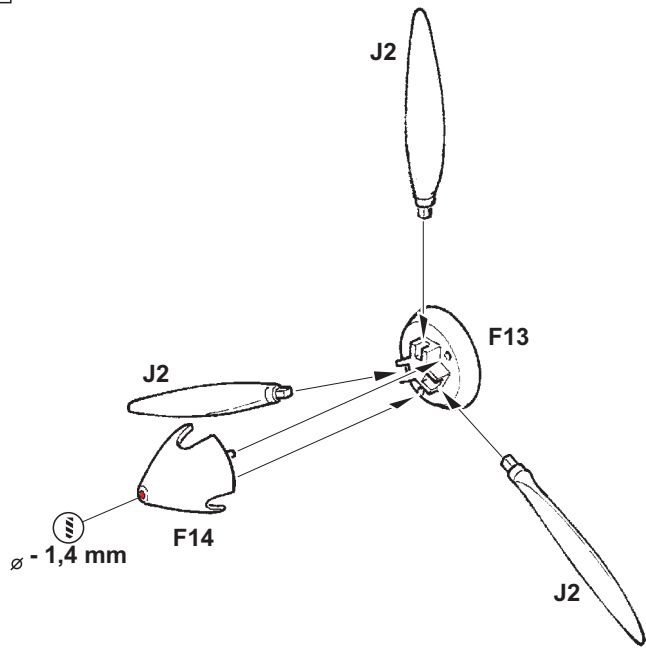
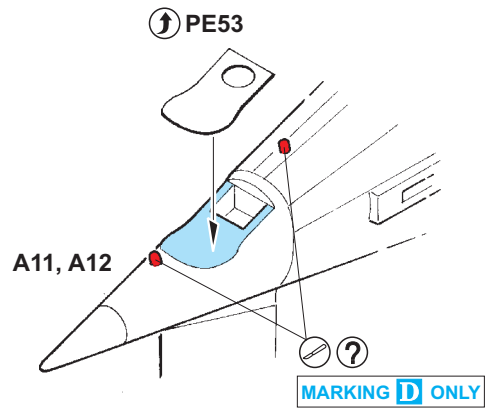
J**K**

RP3 - MARKINGS D:F
 RP4 - MARKINGS A:B:C:E

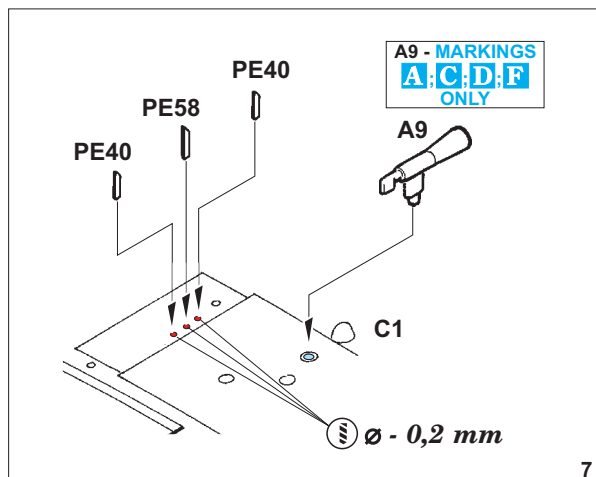
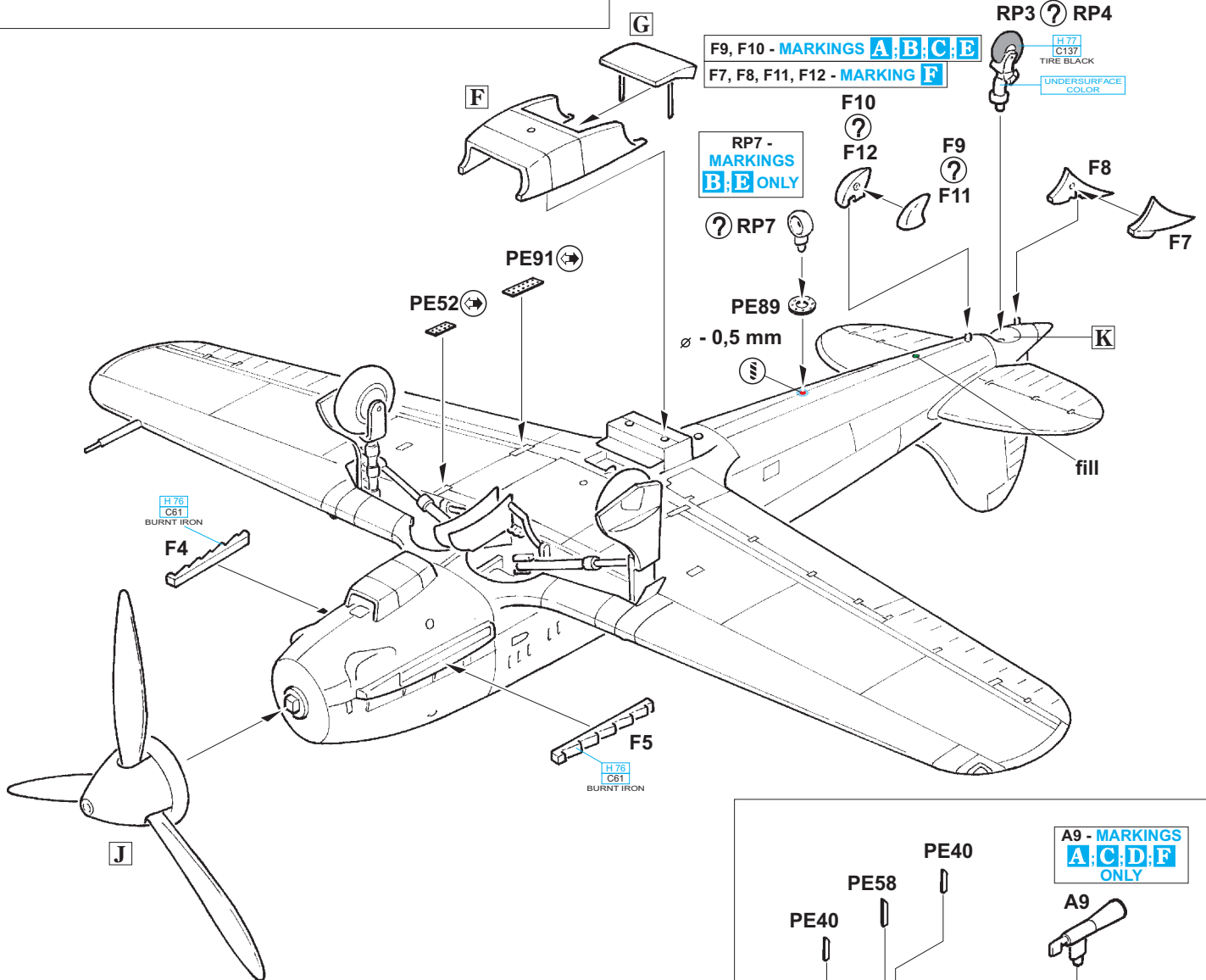

M2 - MARKINGS **D; F**
 M4 - MARKINGS **A; B; C; E**

M2 ? M4

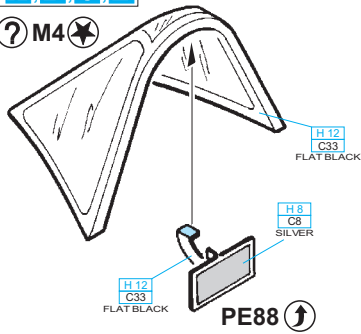

PE88 - MARKINGS **A; B; C; E** ONLY

M

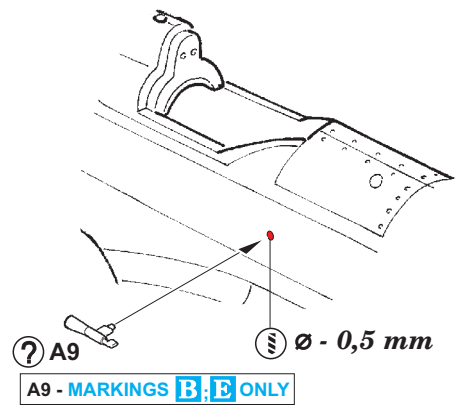
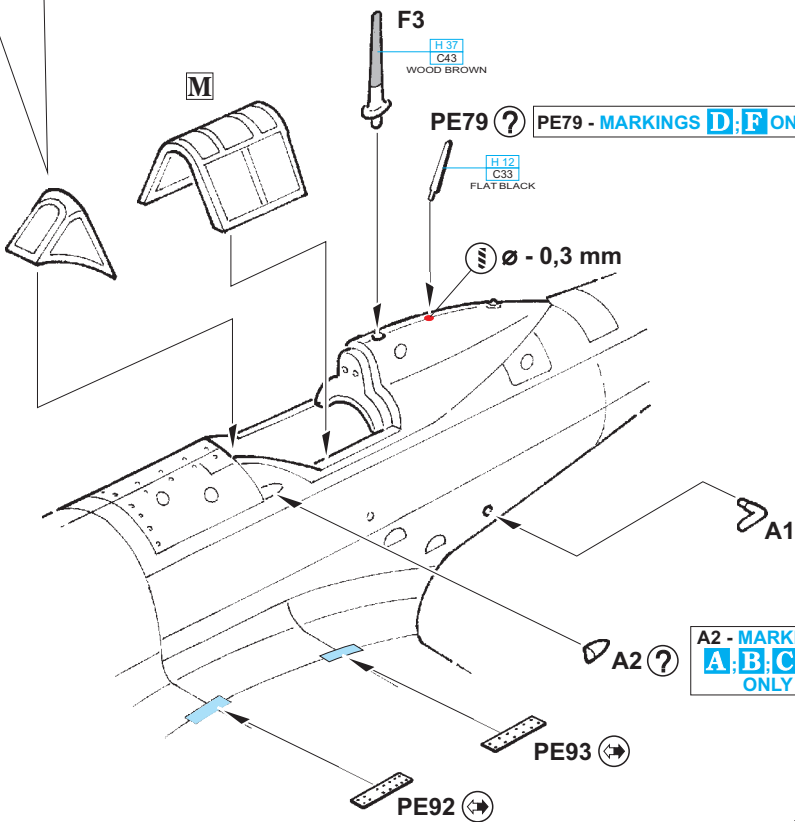
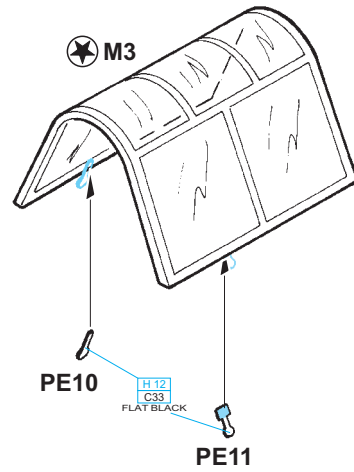

MARKINGS **A; B; C; E** ONLY

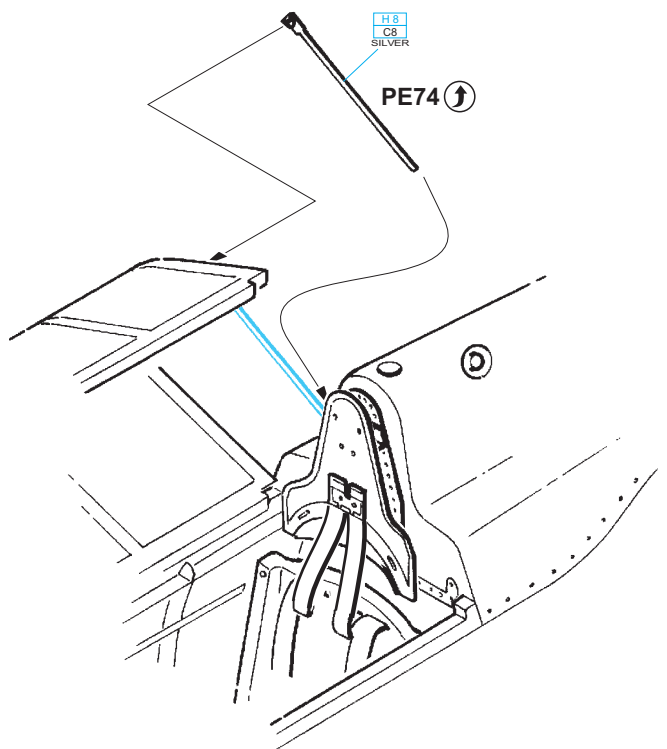
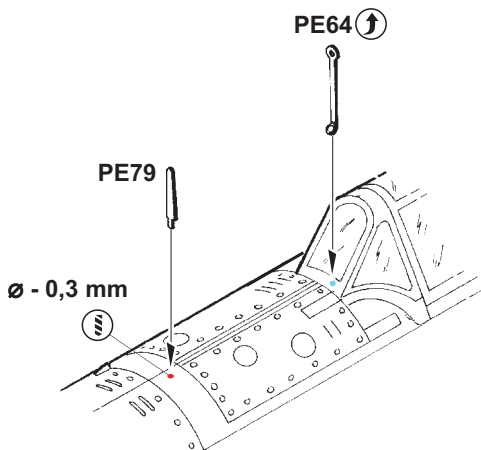

1132

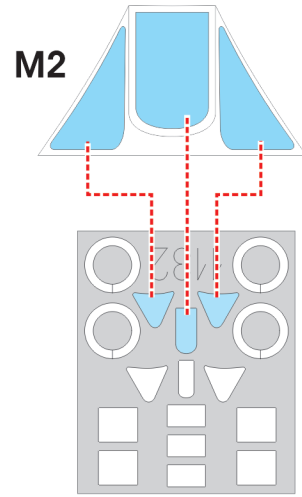
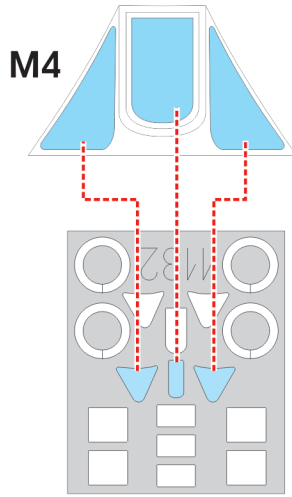
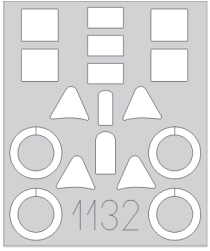

M3 1.)

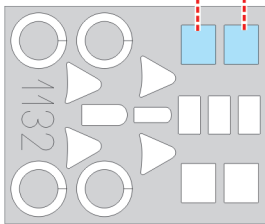
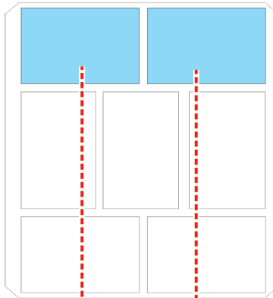

M3 2.)

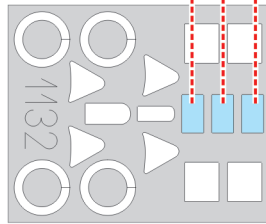
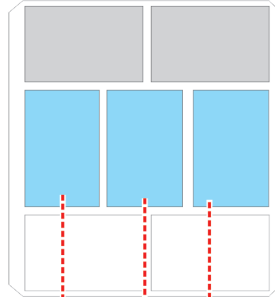

M3 3.)

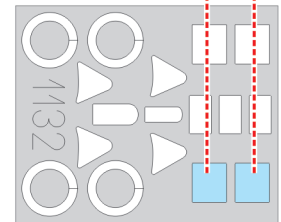
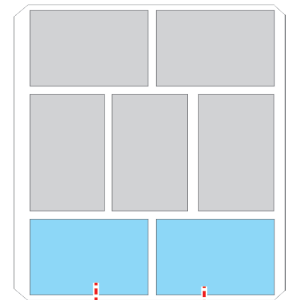

RP1

2 pcs.

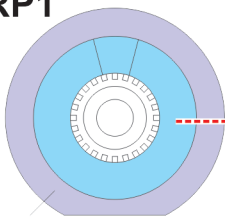

LIQUID
MASK

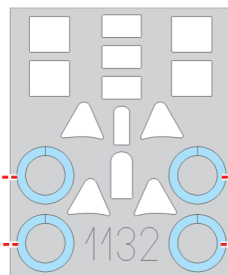

RP2

2 pcs.

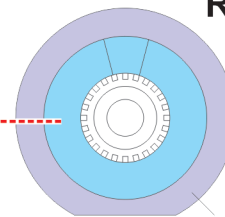

LIQUID
MASK

A Macchi C.202 VII. Serie, M.M.9066, Maresciallo Ennio Tarantola, 151a Squadriglia, 51° Stormo C.T., Gela, September 1942

Italian ace Ennio Tarantola began his career as a fighter pilot back in the Spanish Civil War, where he flew the Fiat CR.32. After the end of that conflict, he flew Ju 87B divebombers, with which he recorded success against a British destroyer. Later, he returned to being a fighter pilot, and served with the 20° Gruppo on the G.50 and, later, the C.202. After the Armistice, he served in the ranks of the Aeronautica Nazionale Repubblicana, the air force of Repubblica Sociale Italiana, a state formed on territory controlled by German forces on September 18, 1943 after the Armistice. He ended the war with ten kills. While serving at Gela, he was in 151a Squadriglia commanded by Furio Niclot Doglio, flying the illustrated aircraft, which was built at Macchi and was camouflaged with olive green smoke rings on a hazelnut brown base. The engine cowl carried the inscription 'Dai Banana!' (Onwards, Banana), a reference to his pre-war job as a banana vendor in the town of Como.

ČESKOU VERZI TEXTU NALEZNETE NA www.eduard.com/s/1132



BLACK	H12 33	WHITE	H11 62	VERDE OLIVA SCURO 2	H65 18
YELLOW	H4 4	GRIGIO AZZURRO CHIARO 1	H324 324	NOCCIOLA CHIARO 4	1
				75% H310 310	+25% H79 39

B Macchi C.202 XII. Serie, M.M. Unknown, 70a Squadriglia, 3° Stormo C.T., Cerveteri, August 1943

This aircraft manufactured by Breda carried the characteristic late camouflage scheme consisting of olive green blotches over hazelnut brown on all surfaces except the lower, which were in the usual blue-grey. The demarcation between the upper and lower colours is also typical for Breda. The illustrated aircraft carried the additional wing guns and under-fuselage compass antenna. Fascist Regia Aeronautica markings were removed after July 25, 1943, when Mussolini was stripped of his leadership and imprisoned. On the wings, insignia was either resprayed in their entirety using the normal camouflage colors, or just the black rings remained. The Savoie Dynasty coat of arms lost the rod bundles enclosing the axe.

ČESKOU VERZI TEXTU NALEZNETE NA
www.eduard.com/s/1132



BLACK	H12 33	WHITE	H11 62	VERDE OLIVA SCURO 2	H65 18
YELLOW	H4 4	GRIGIO AZZURRO CHIARO 1	H324 324	NOCCIOLA CHIARO 4	1
			75% H310 310	+25% H79 39	

C Macchi C.202 VI. Serie, M.M.8122, 386a Squadriglia, 21° Gruppo Autonomo C.T., Kantemirowka, October 1942

This machine manufactured by Breda carried that facility's typical olive green over hazelnut brown camouflage scheme on the upper surfaces, and blue-grey on the bottom. The yellow markings were designated for aircraft used on the Eastern Front, to which the Italians also added the white triangles on the leading edges of the wings. The rudder carried the 21° Gruppo Autonomo C.T. unit marking on both sides.

ČESKOU VERZI TEXTU NALEZNETE NA
www.eduard.com/s/1132



BLACK	H12 33	WHITE	H11 62	VERDE OLIVA SCURO 2	H65 18
YELLOW	H4 4	GRIGIO AZZURRO CHIARO 1	H324 324	NOCCIOLA CHIARO 4	1
				75% H310 310	+25% H79 39

D Macchi C.202 II. Serie, M.M.7711, 378a Squadriglia, 155° Gruppo, 51° Stormo C.T., Gela, August 1942

Early series aircraft off the Macchi production line showing typical intake lacking a sand filter, windscreen sans armoured glass centre section and antenna without the later mast. Although this aircraft was photographed in August, 1942, it still carried a camouflage scheme in initial colours, and this despite newer colours coming into use already by 1941. Upper engine cowl came from another aircraft.

ČESKOU VERZI TEXTU NALEZNETE NA
www.eduard.com/s/1132



VERDE MIMETICO 2	H302	302	VERDE MIMETICO 3	H303	303	VERDE OLIVA SCURO 2	H65	18
BRUNO MIMETICO	H37	43	WHITE	H11	62	GIALLO MIMETICO 4	H79	39
BLACK	H12	33	GRIGIO MIMETICO	H317	317	NOCCIOLA CHIARO 4	1	75% H310 +25% H79

E Macchi C.202 XI. Serie, M.M. Unknown, 24° Gruppo Autonomo C.T., Olbia-Venafiorita, June 1943

An late series aircraft built at Breda, again sporting the olive green – hazelnut brown camouflage scheme characteristic of that plant. The wings were donor items from an aircraft built by Macchi as indicated by the smoke ring camouflage in olive green over hazelnut brown. 24° Gruppo Autonomo was tasked with Mediterranean convoy escort duties and in 1943 played a vital role in the defence of Sicily against allied air raids. The white nose of this aircraft indicates its previous use by 1° Stormo C.T.

ČESKOU VERZI TEXTU NALEZNETE NA
www.eduard.com/s/1132

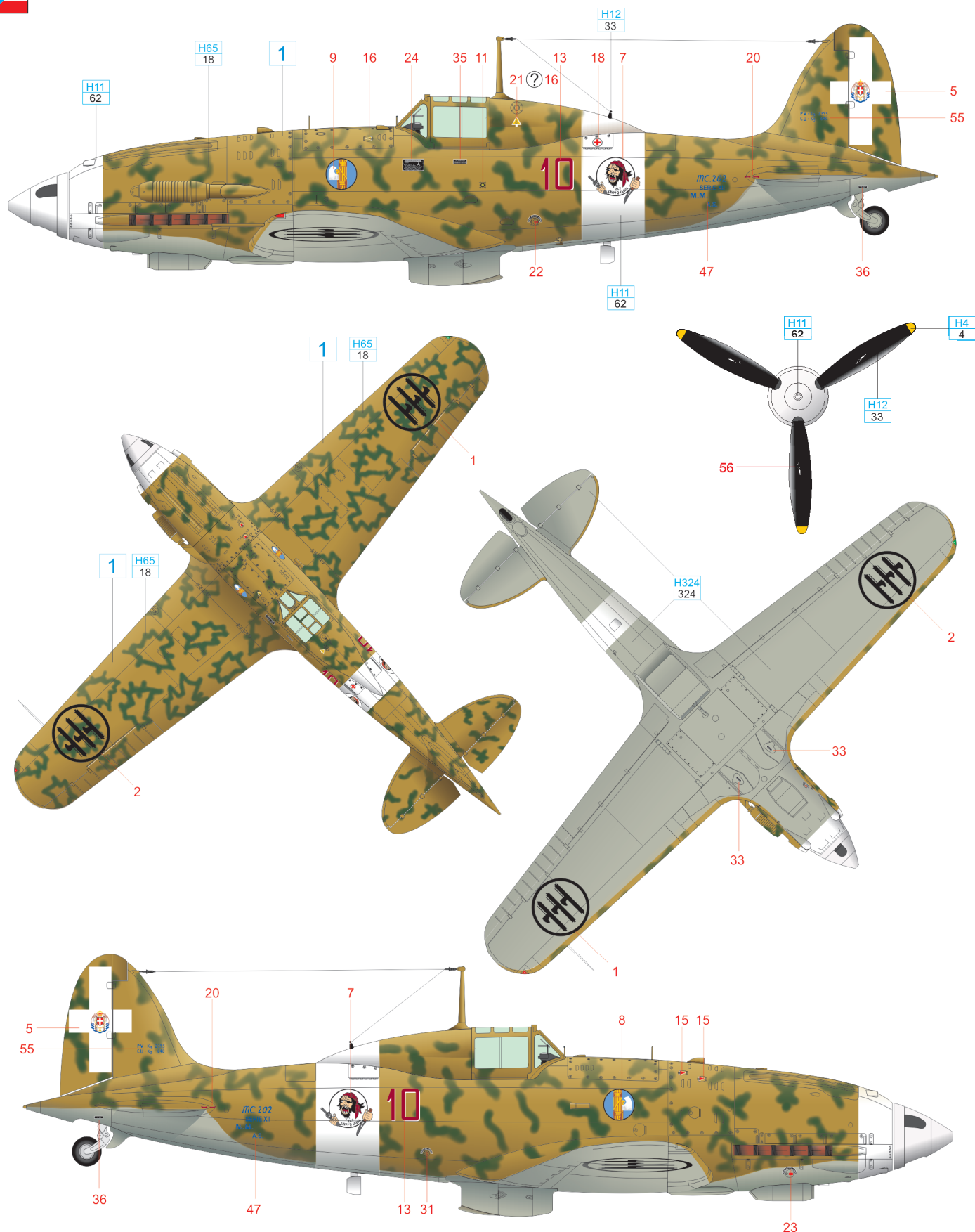

BLACK	H12 33	WHITE	H11 62	VERDE OLIVA SCURO 2	H65 18
YELLOW	H4 4	GRIGIO AZZURRO CHIARO 1	H324 324	NOCCIOLA CHIARO 4	1
				75% H310 310	+25% H79 39

F Macchi C.202 I. Serie, M.M.7860, 71a Squadriglia, 17° Gruppo, 1° Stormo C.T., Udine-Campoformido, October 1941

Initial series aircraft built by Breda camouflaged as per summer 1941 directives called the 'Continental Camouflage Scheme'. This was composed of upper surfaces in olive green and lower surfaces in blue-grey. The 1° Stormo unit emblem is carried inside the white fuselage band. At Campoformido, the unit prepared to engage the British in North Africa. The aircraft displays characteristics typical of initial production, such as a lack of sand filter on the intake, no armoured glass in the windscreen and no antenna mast.

ČESKOU VERZI TEXTU NALEZNETE NA
www.eduard.com/s/1132

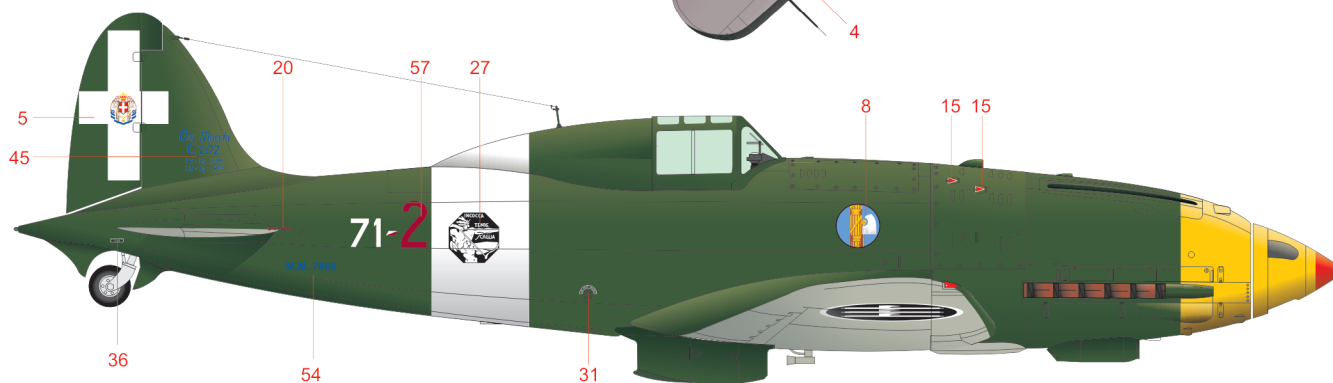
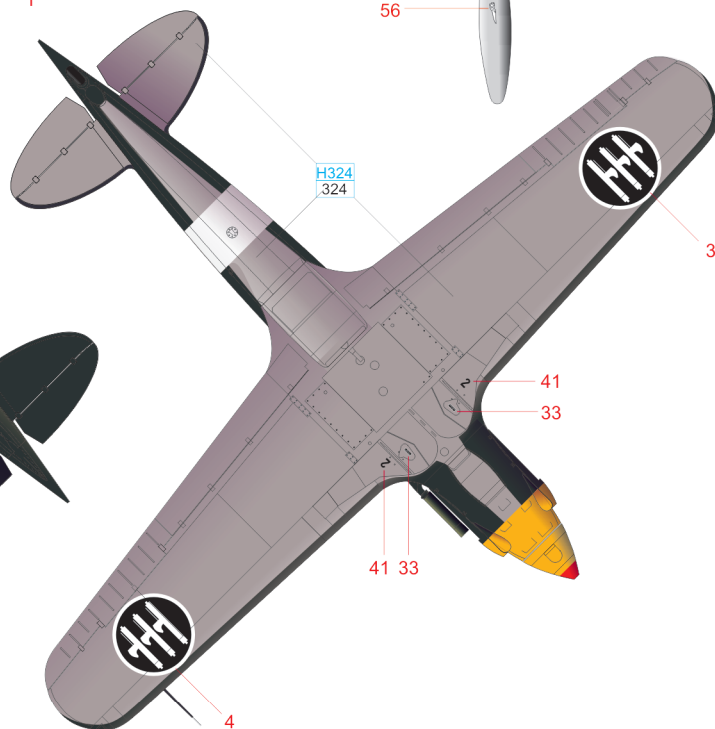
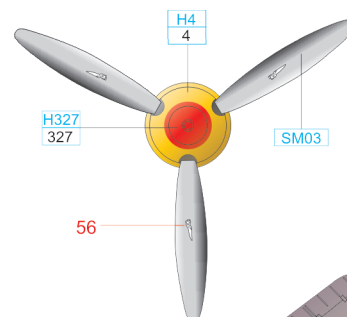
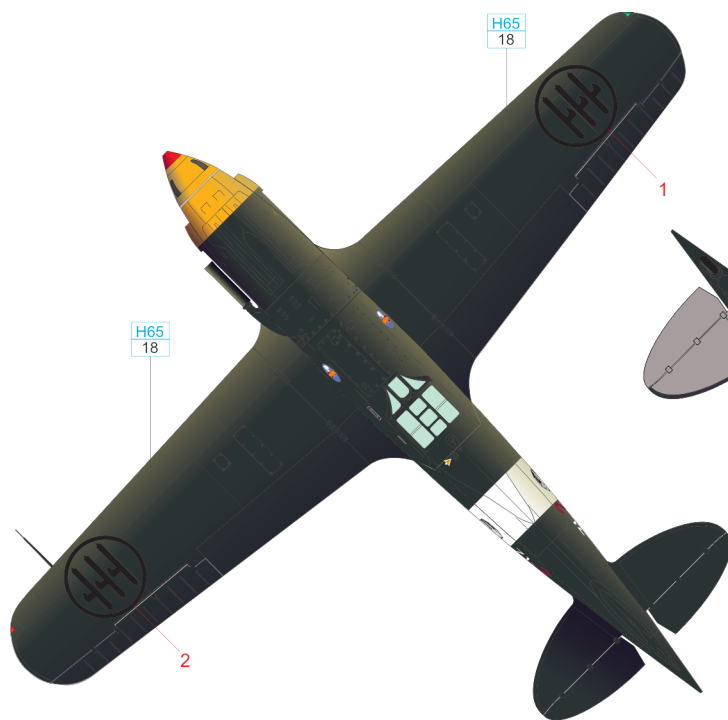
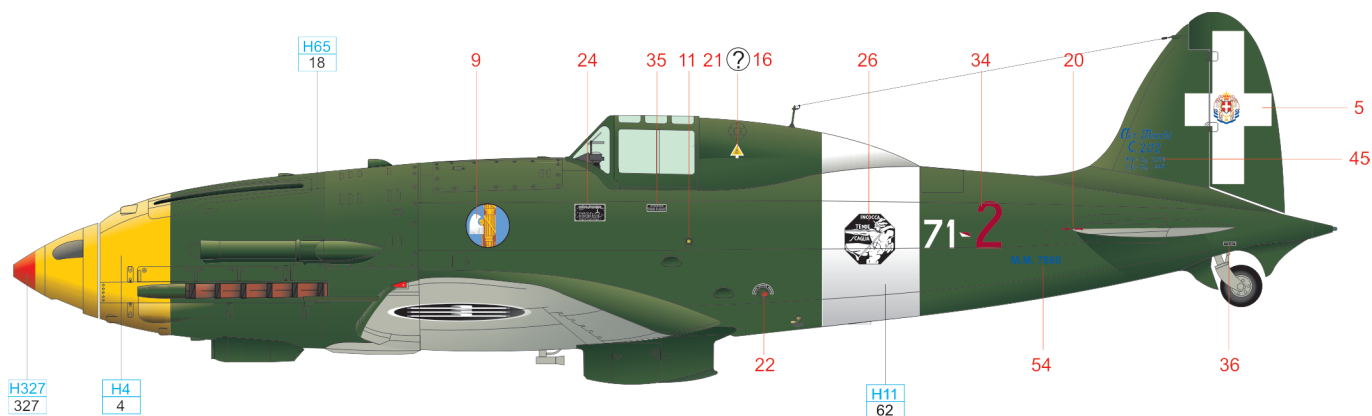

WHITE	H11 62	RED	H327 327	IRON	SM03
YELLOW	H4 4	GRIGIO AZZURRO CHIARO 1	H324 324	VERDE OLIVA SCURO 2	H65 18

eduard