

BEDFORD QL Refueller



Cat. no. 35062

Scale 1/35



3D Design & Artwork: Jarosław Leoniec
Research: IBG crew

Przed montażem przeczytać instrukcję. Przestrzegać kolejności montażu podanego w instrukcji! Klej i farby nie wchodzi w skład zestawu.
Please read instruction before assembly. Obey sequence of assembly like in instruction. Glue and paints not included.

- Element złożony we wcześniejszym etapie
Element assembled in previous step
- Element po złożeniu w aktualnym etapie
Element after assembly in actual step
- Wersja do wyboru
Version to choose
- Kalkomania
Decal
- Kolor farby
Paint colour
- Część nie do użycia
Part not for use
- Zegnij część fototrawioną
Bend photoetched part
- Po gięciu
After bending

		Vallejo Model Air	Hataka	Mr Hobby H	Mr Hobby C	Lifecolor	AK Interactive
Black	A	71.057	HTK-A159	H002	C002	LC02	AK719
Light Gray	B	71.050	HTK-A050	H324	C097	UA34	AK2231
RAF Blue Grey	C	71.115	HTK-A145	H042	C328	UA044	AK2162
Golden Yellow	D	71.078	HTK-A275	H004	C004	UA140	AK11041
White	E	71.001	HTK-A049	H011	C062	LC01	RC004
Tire Black	F	71.315	HTK-A041	H077	C137	UA733	AK11027
Rust	G	71.129	HTK-A132	H047	C041	LC32	AK707

Kalkomania / Decal

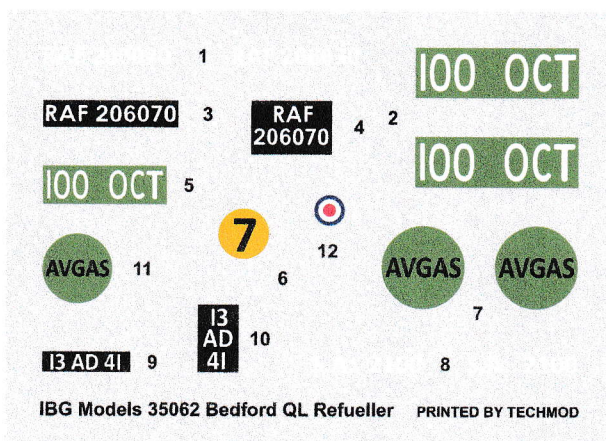

Części fototrawione / Photoetched parts

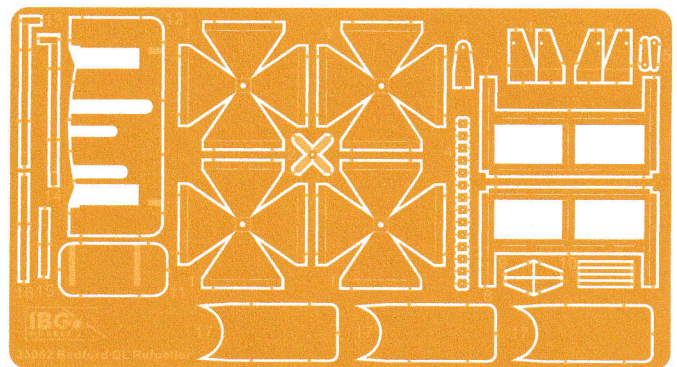

International Business Group
ul. Benedykta Hertza 2
04-603 Warszawa
Poland

tel +48 22 8159150
fax +48 22 8159151
ibgsc@ibg.com.pl
www.ibg.com.pl

**ETAP 1
STEP 1**

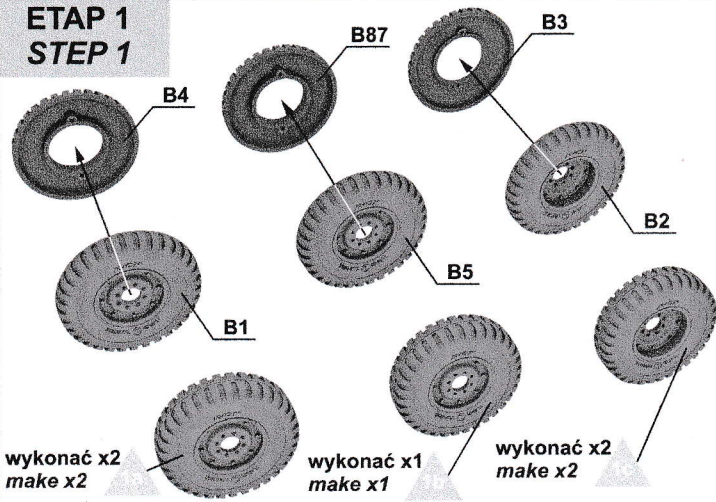

**ETAP 2
STEP 2**

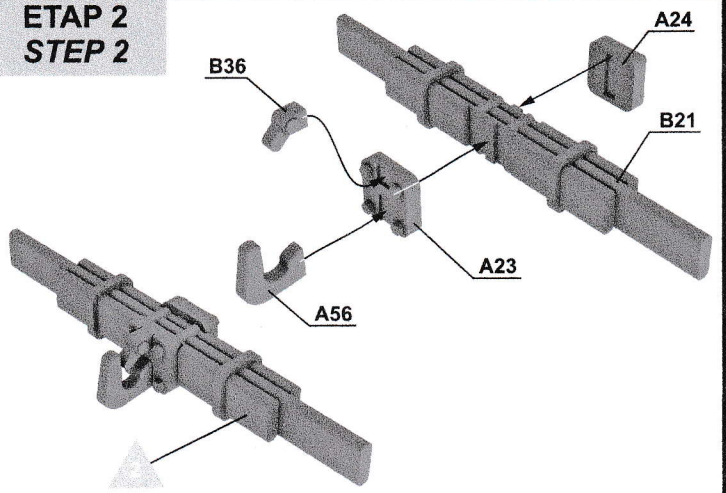

**ETAP 3
STEP 3**

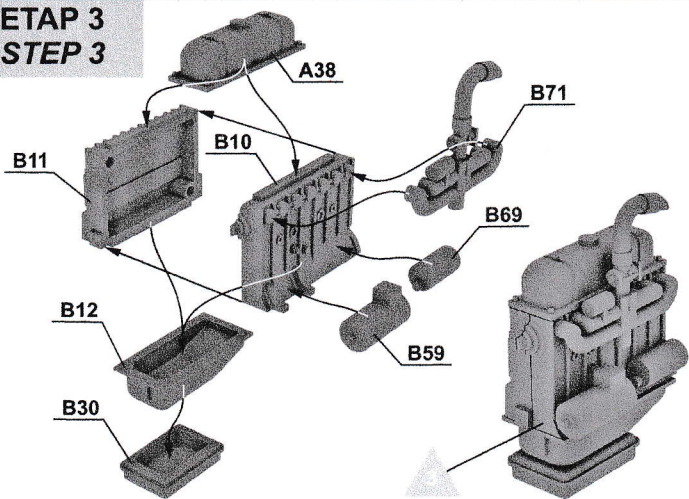

**ETAP 4
STEP 4**

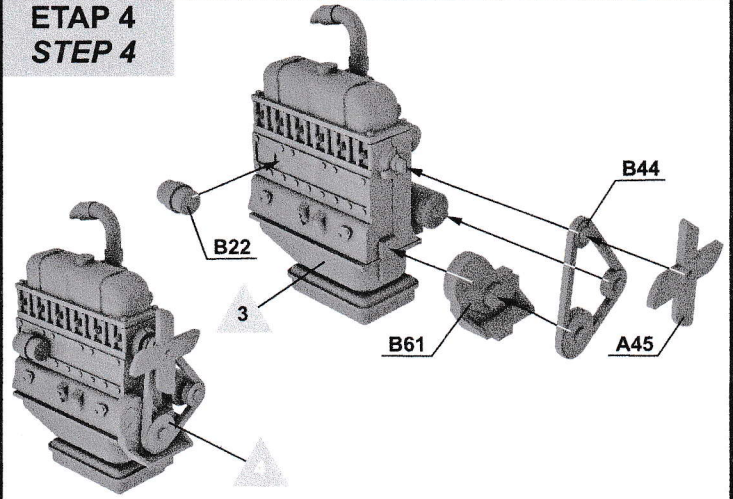

**ETAP 5
STEP 5**

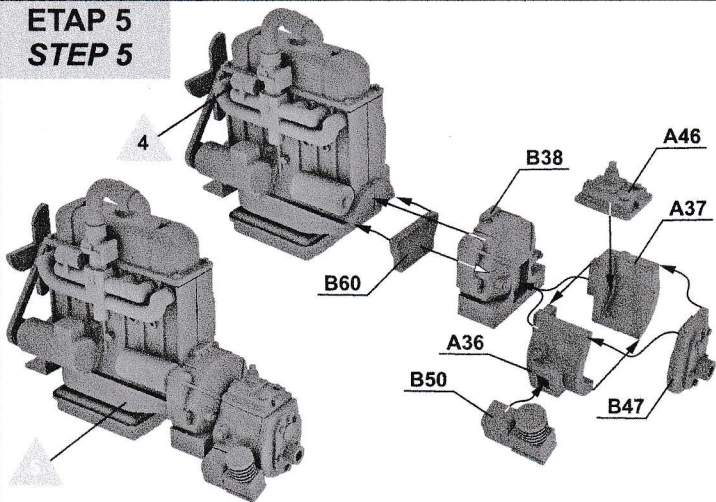

**ETAP 6
STEP 6**

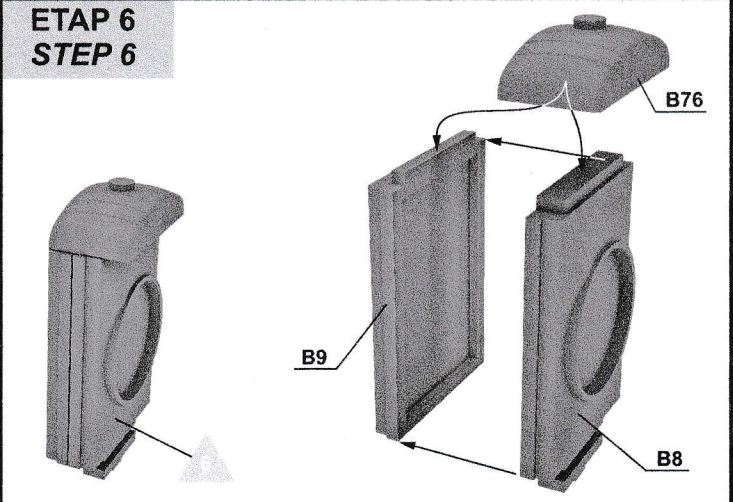

**ETAP 7
STEP 7**

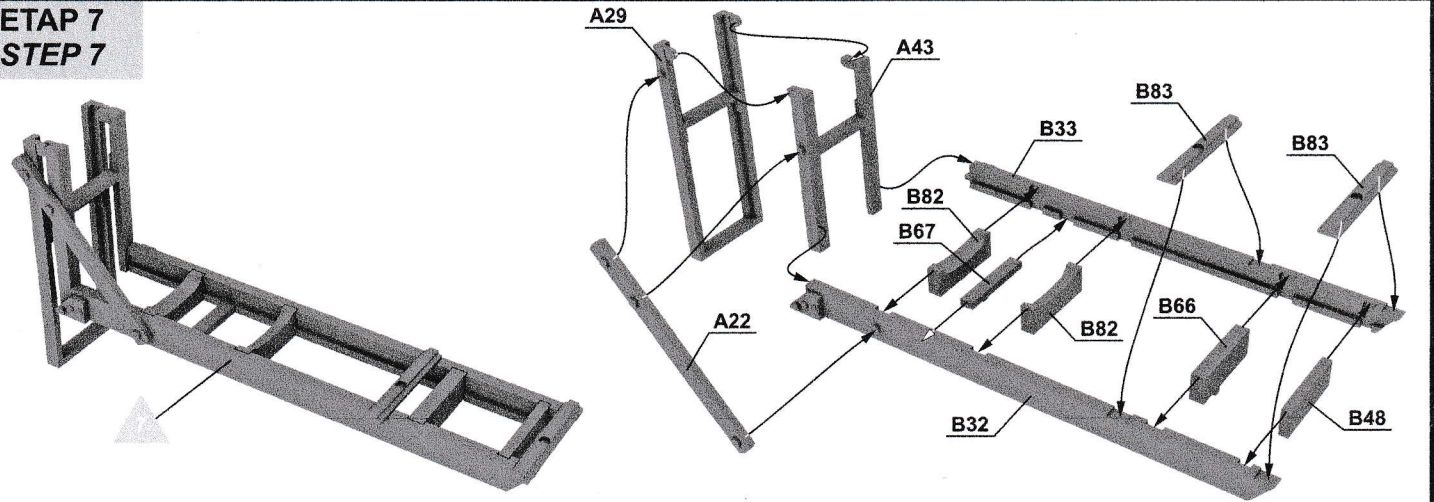

**ETAP 8
STEP 8**

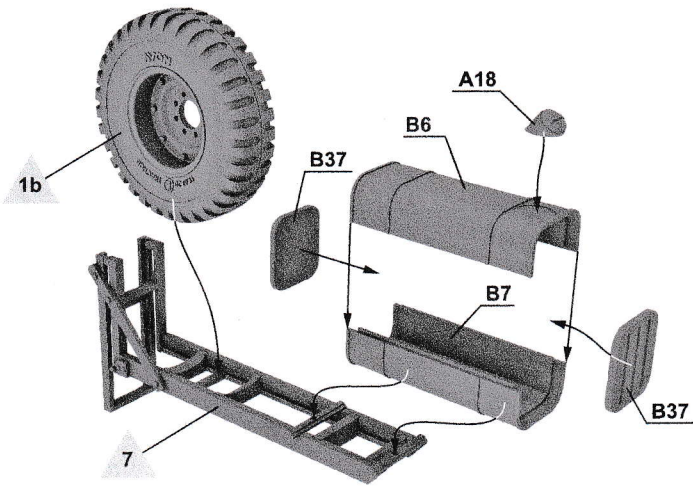
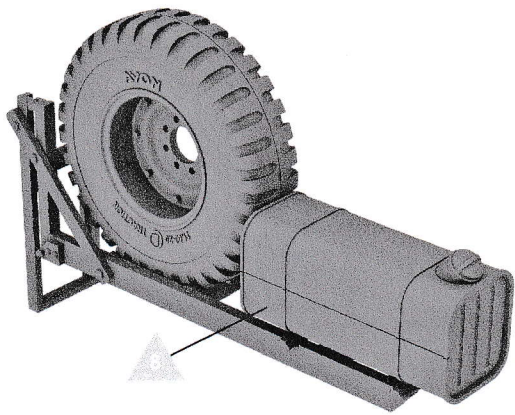

**ETAP 9
STEP 9**

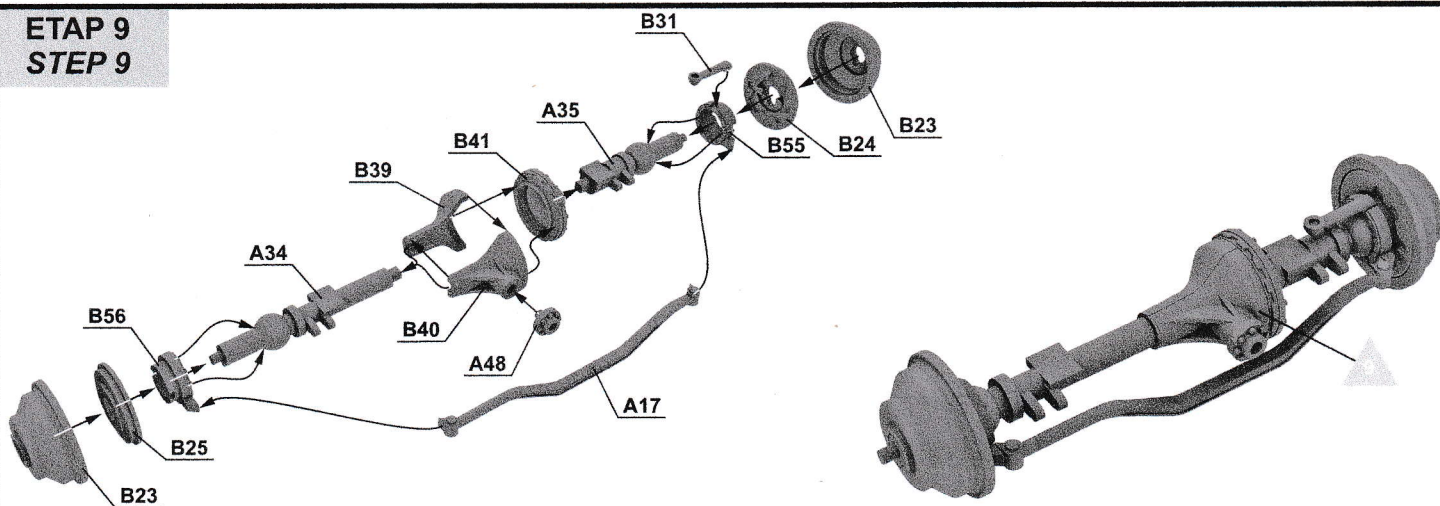

**ETAP 10
STEP 10**

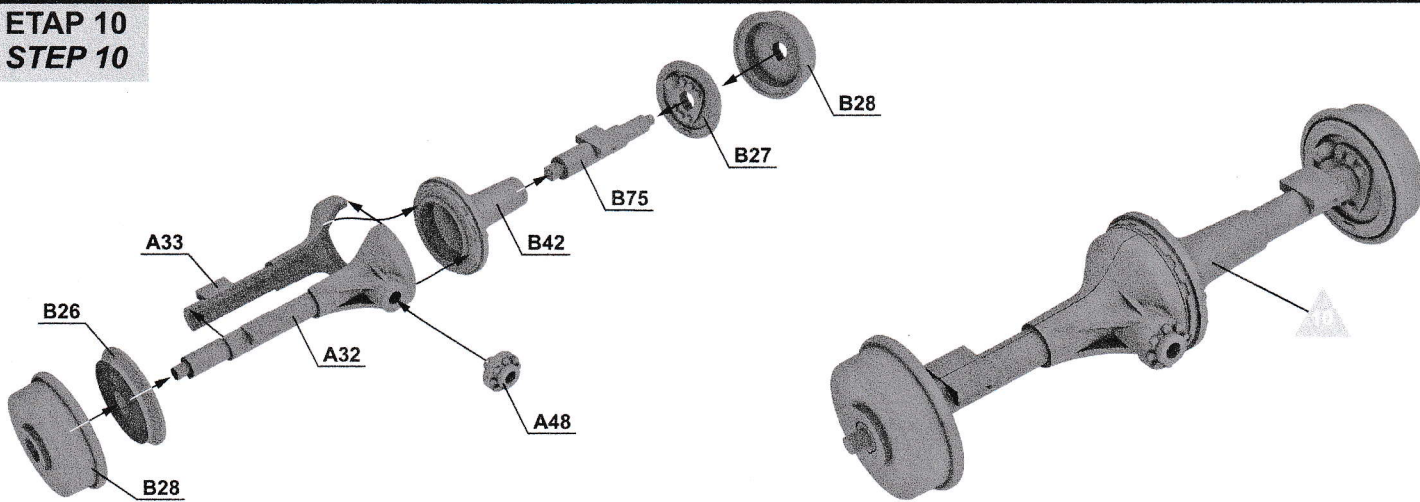

**ETAP 11
STEP 11**

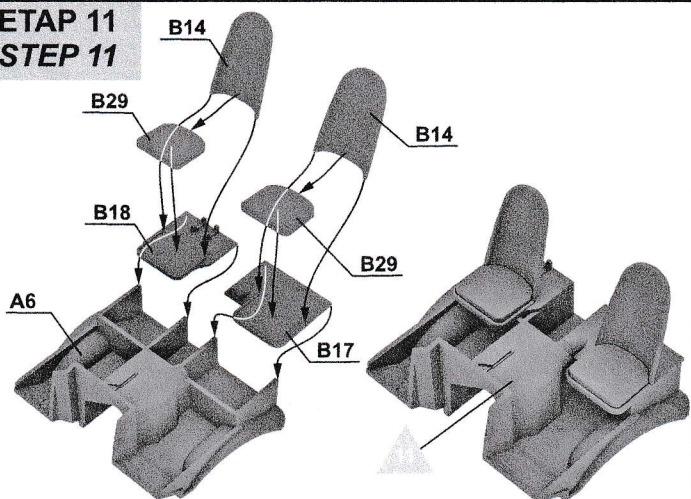

**ETAP 12
STEP 12**

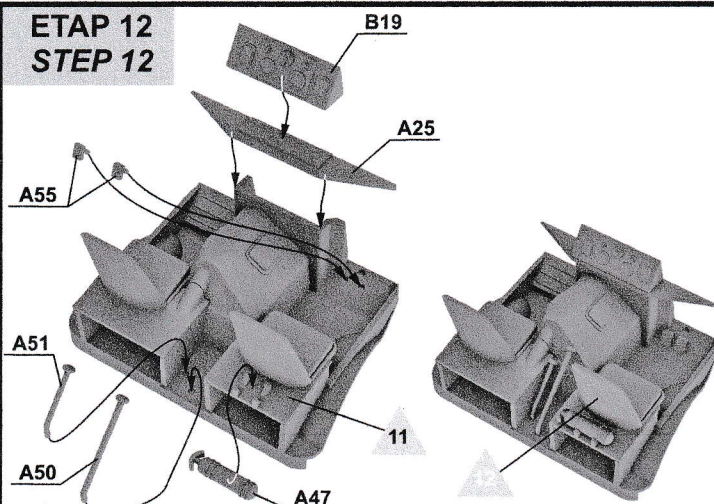

**ETAP 13
STEP 13**

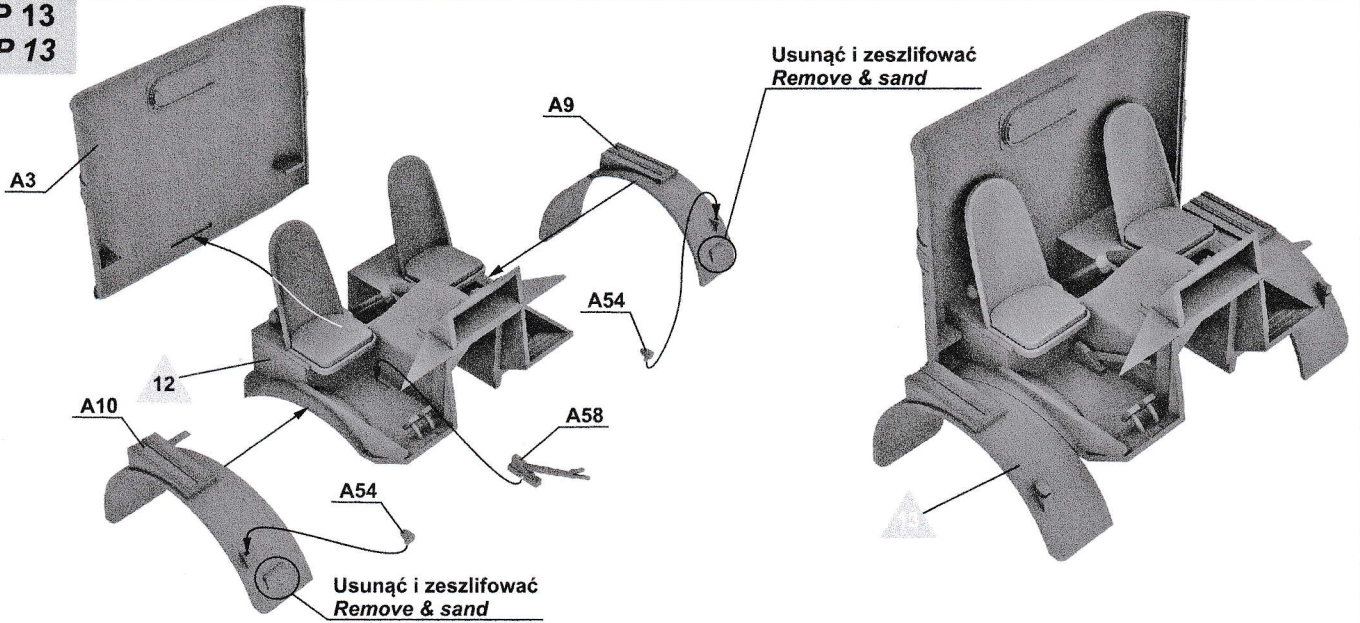

**ETAP 14
STEP 14**

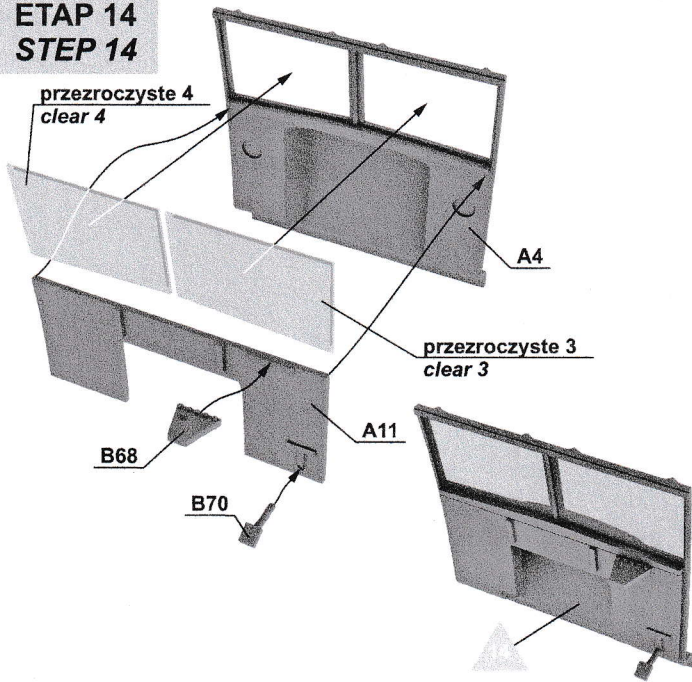

**ETAP 15
STEP 15**

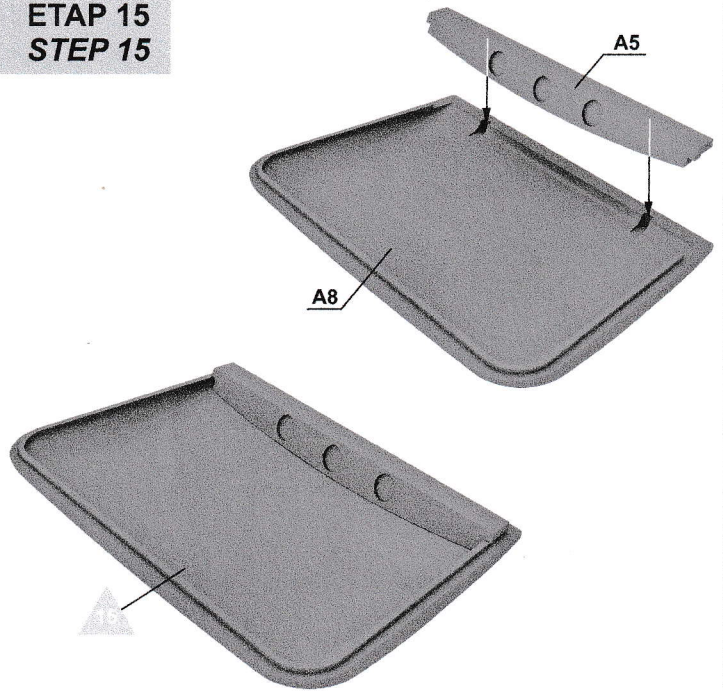

**ETAP 16
STEP 16**

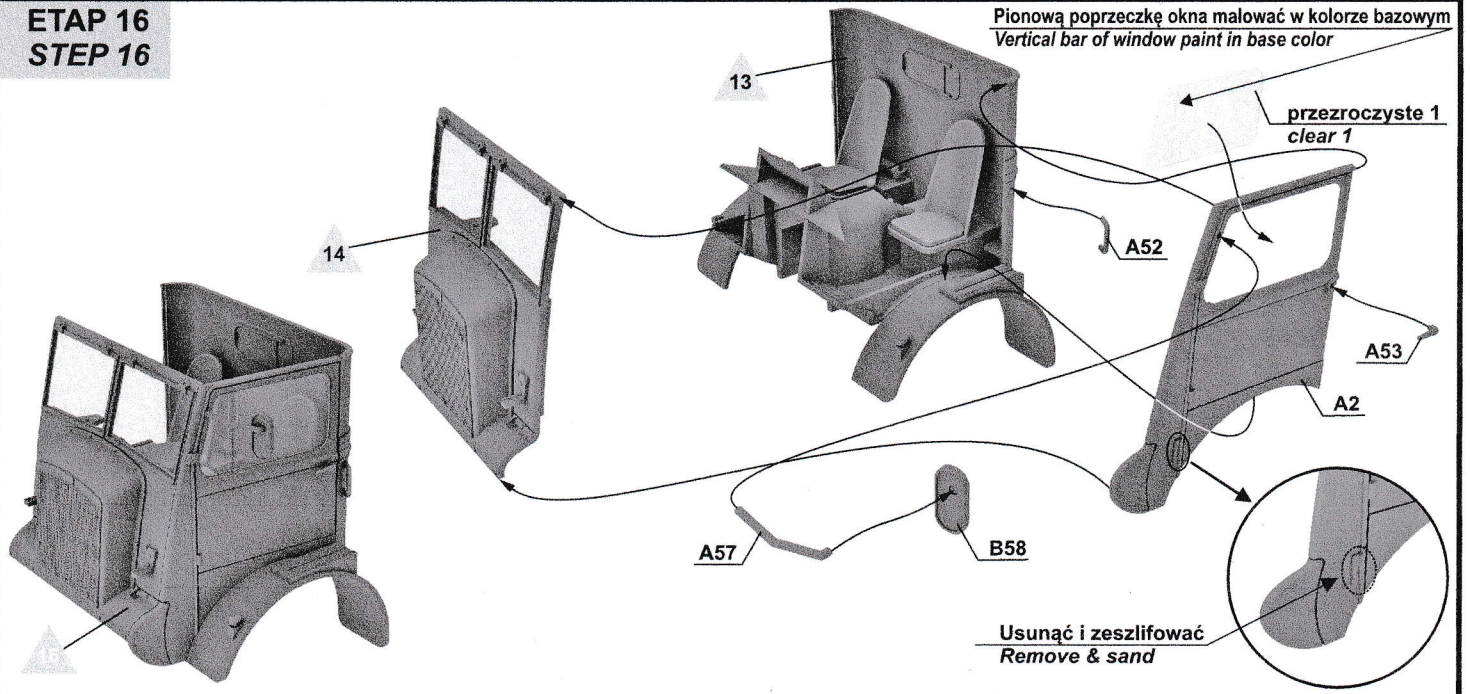

ETAP 17
STEP 17

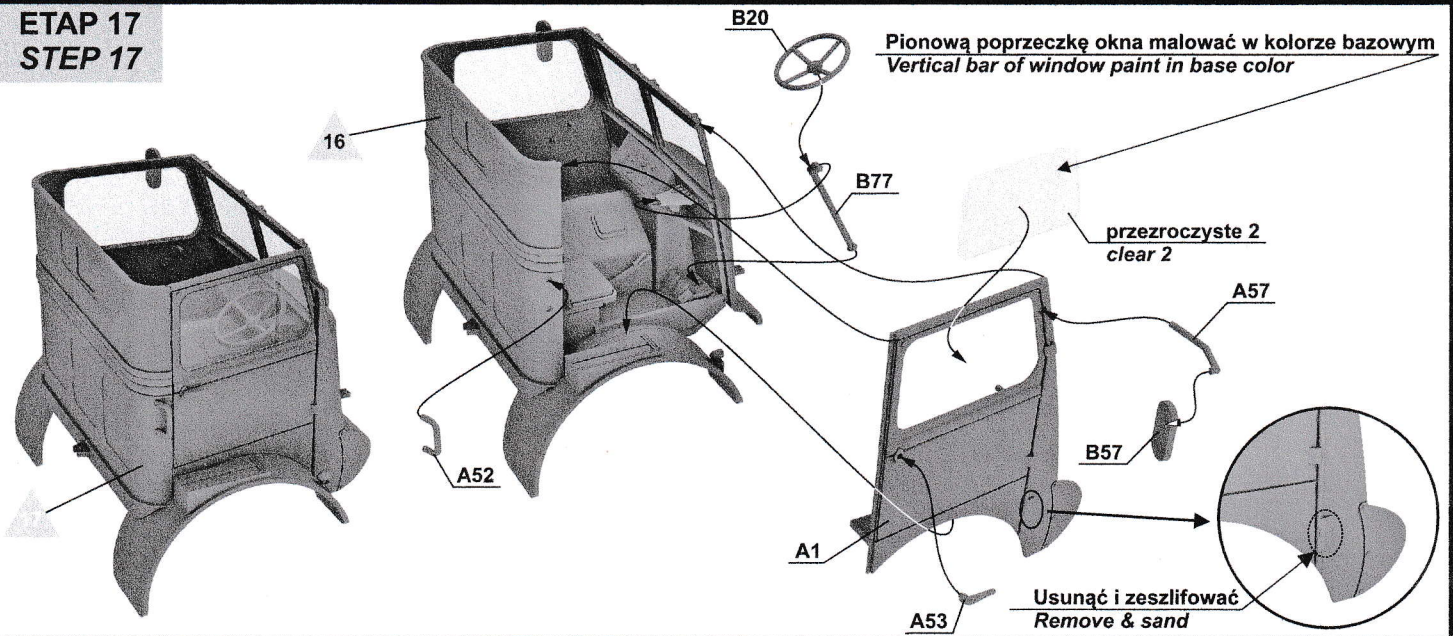

ETAP 18
STEP 18

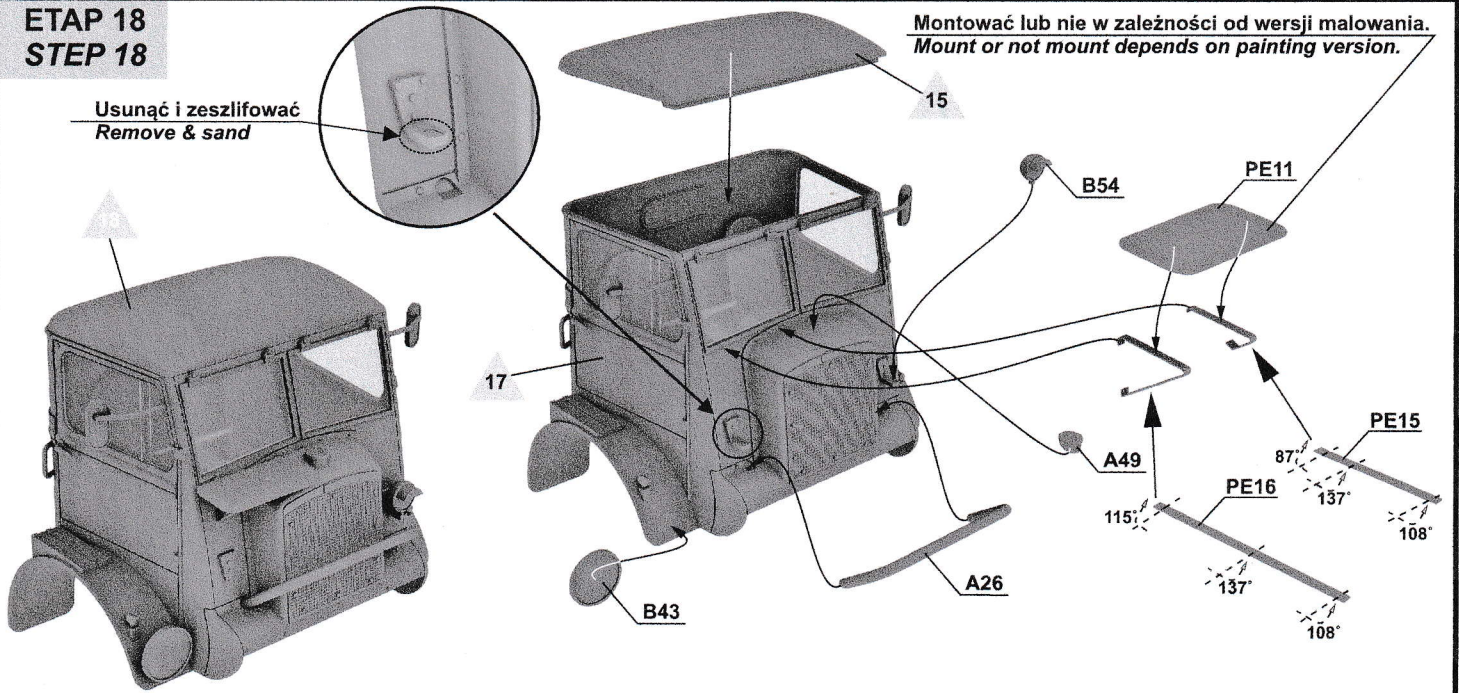

ETAP 19
STEP 19

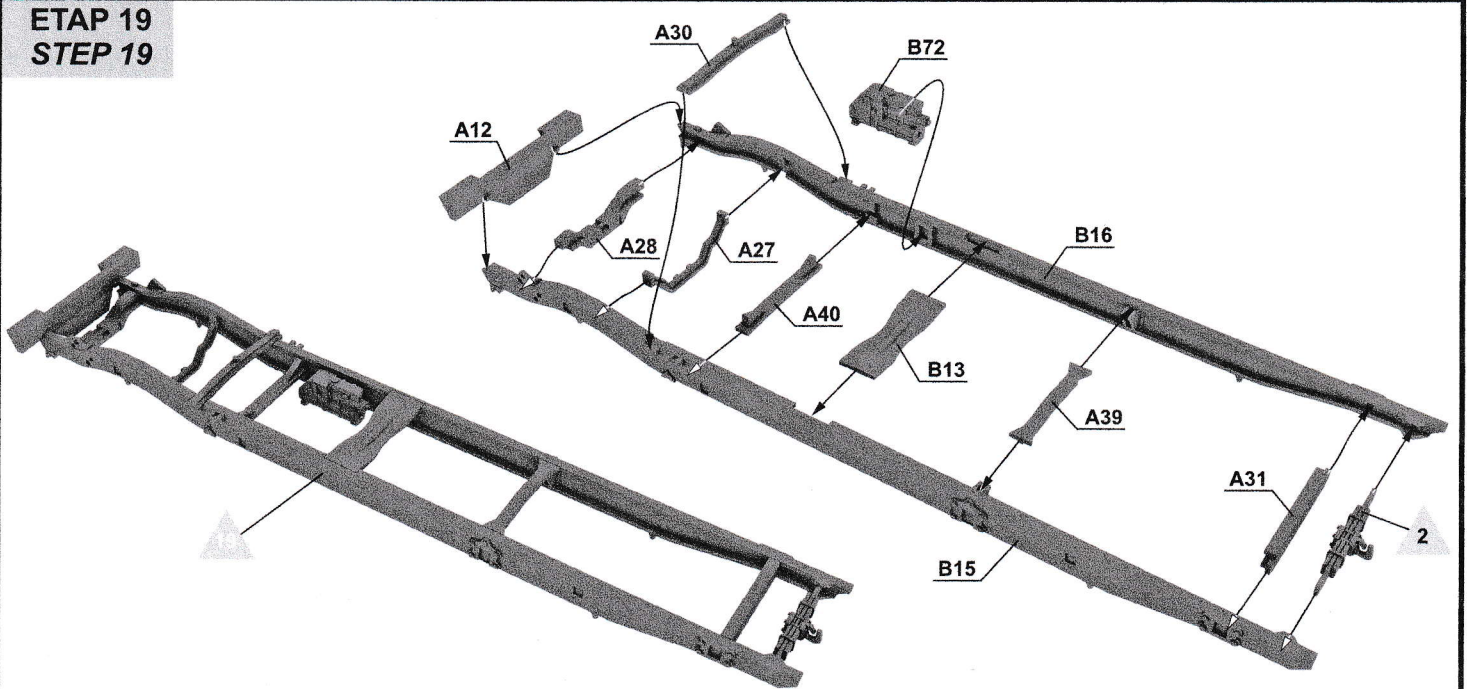

ETAP 20
STEP 20

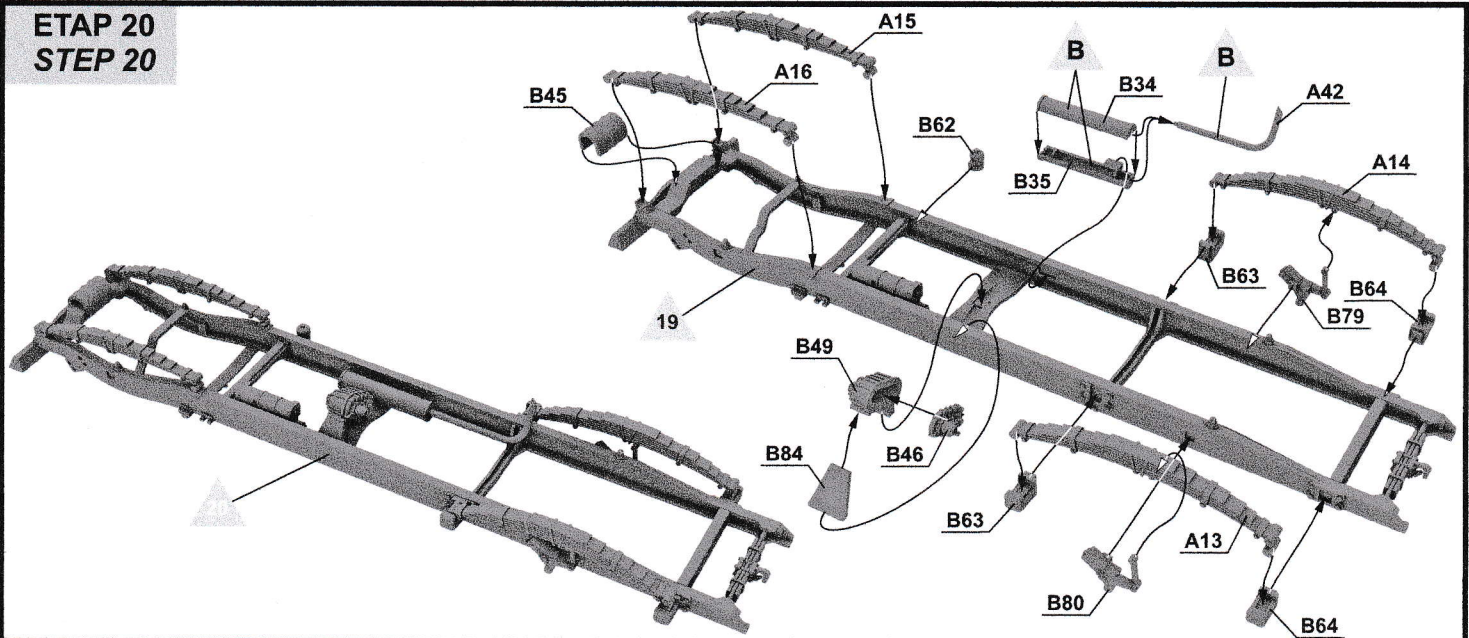

ETAP 21
STEP 21

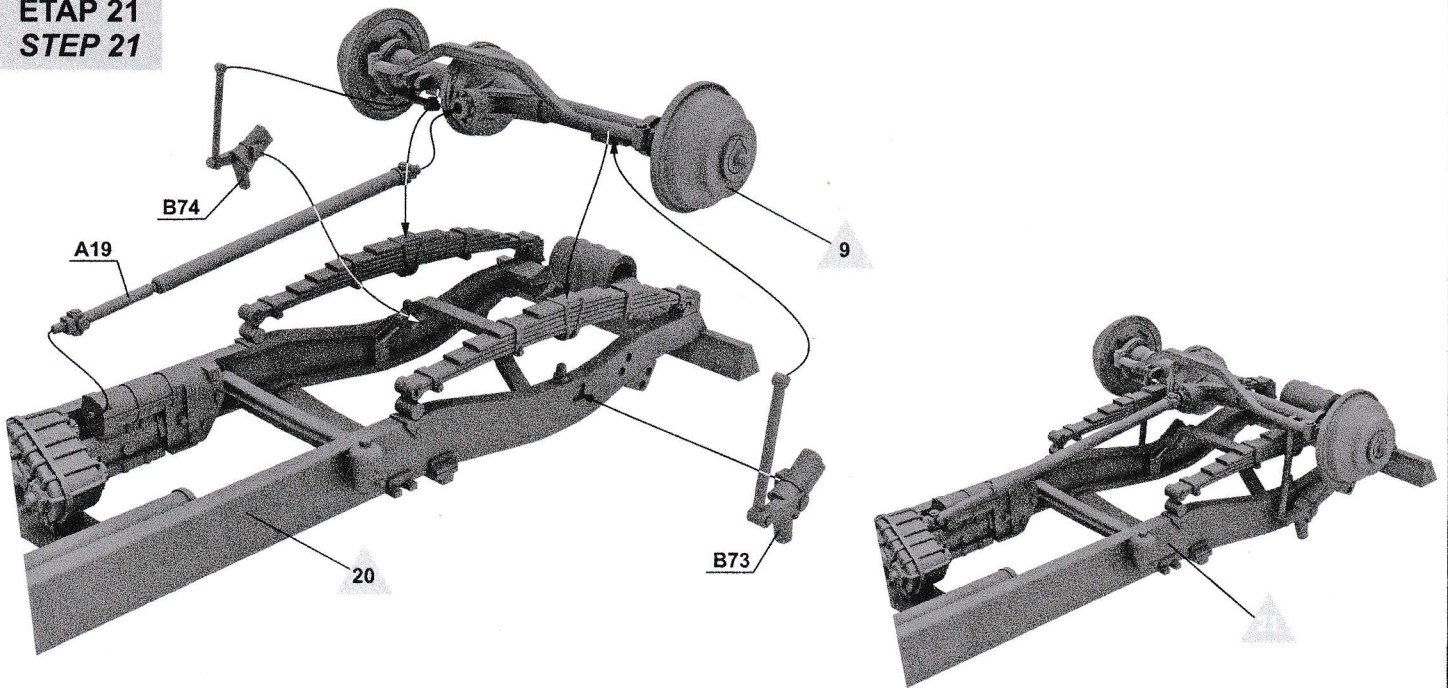

ETAP 22
STEP 22

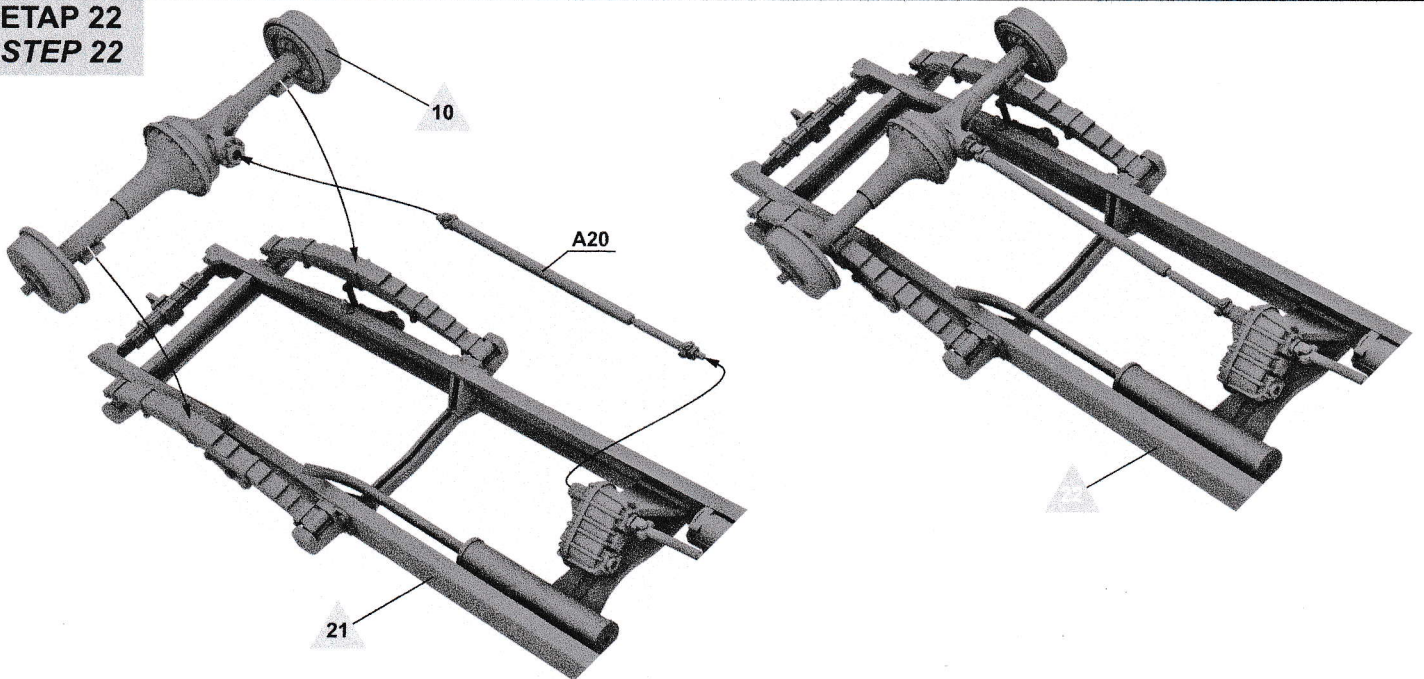

**ETAP 23
STEP 23**

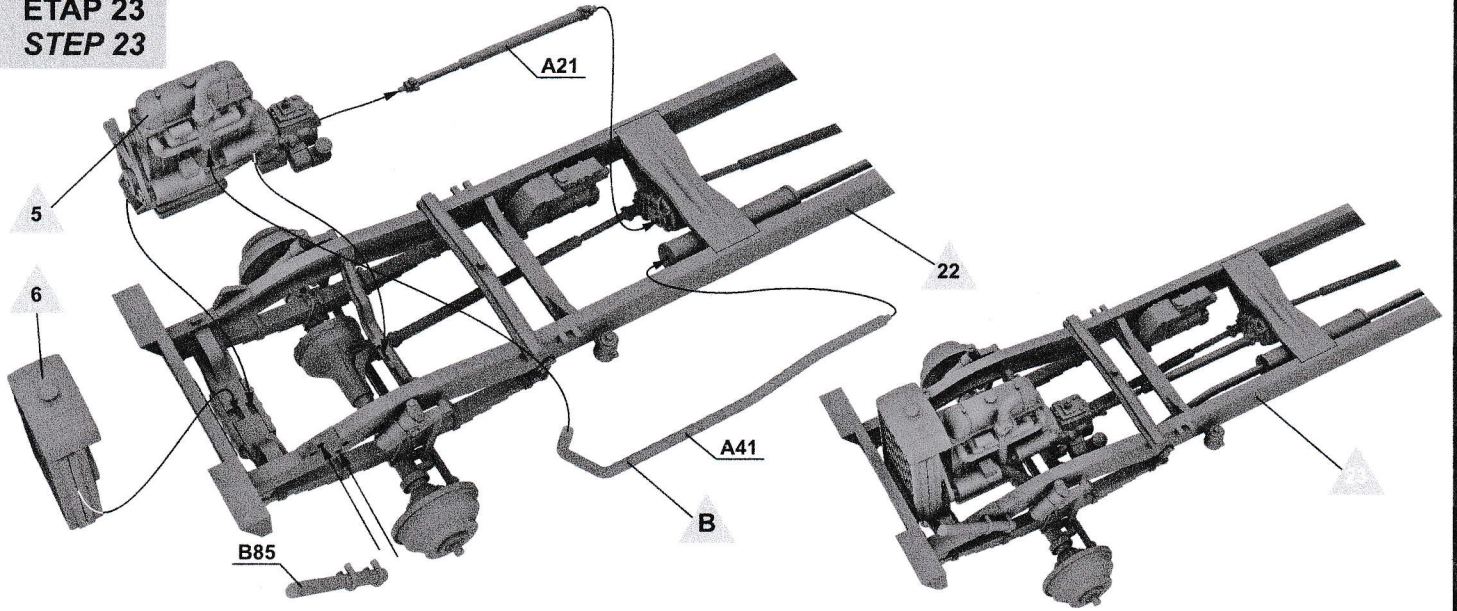

**ETAP 24
STEP 24**

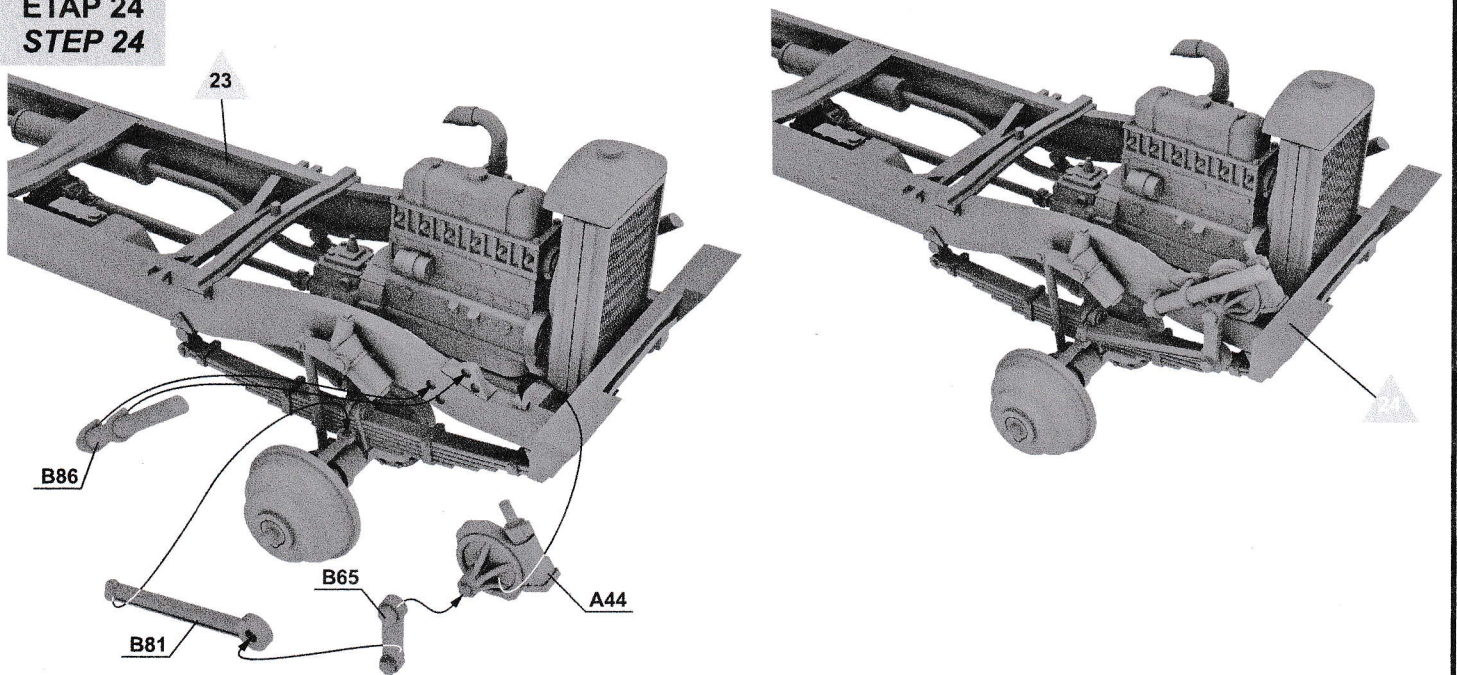

**ETAP 25
STEP 25**

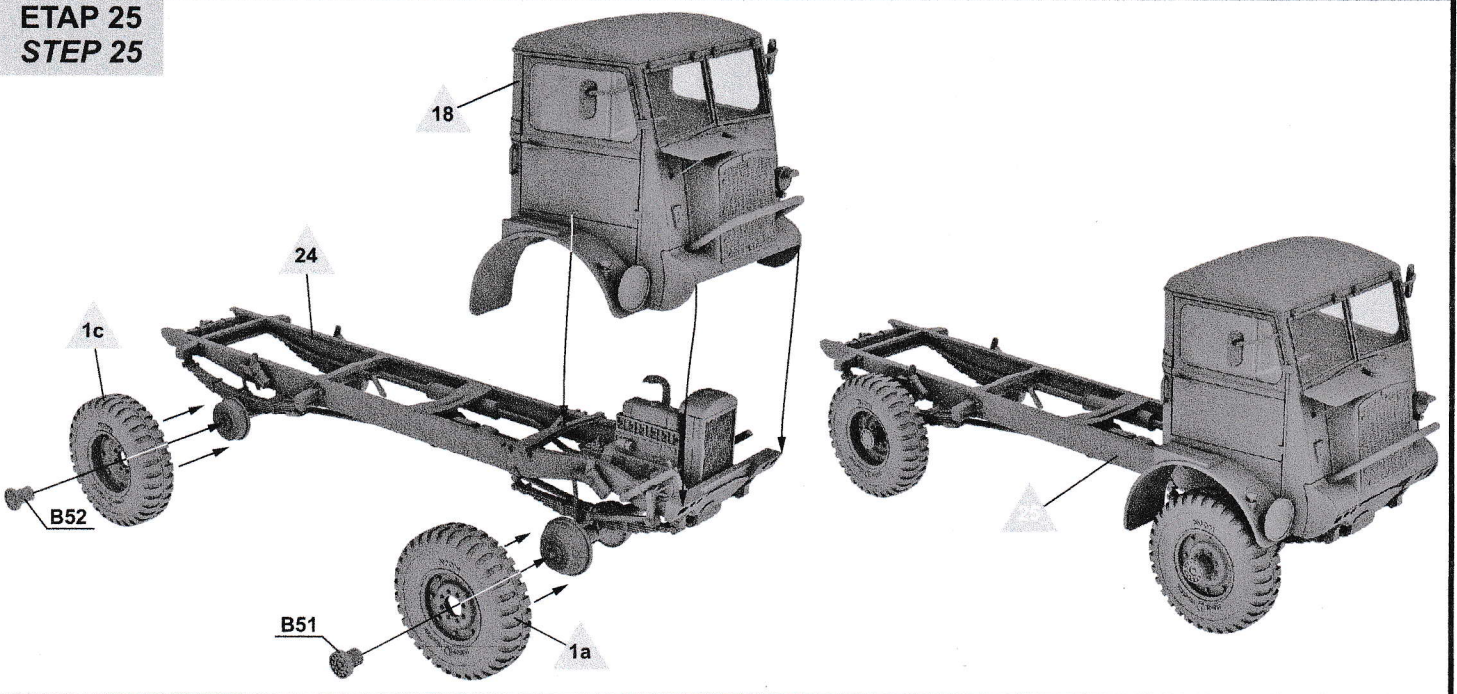

ETAP 26
STEP 26

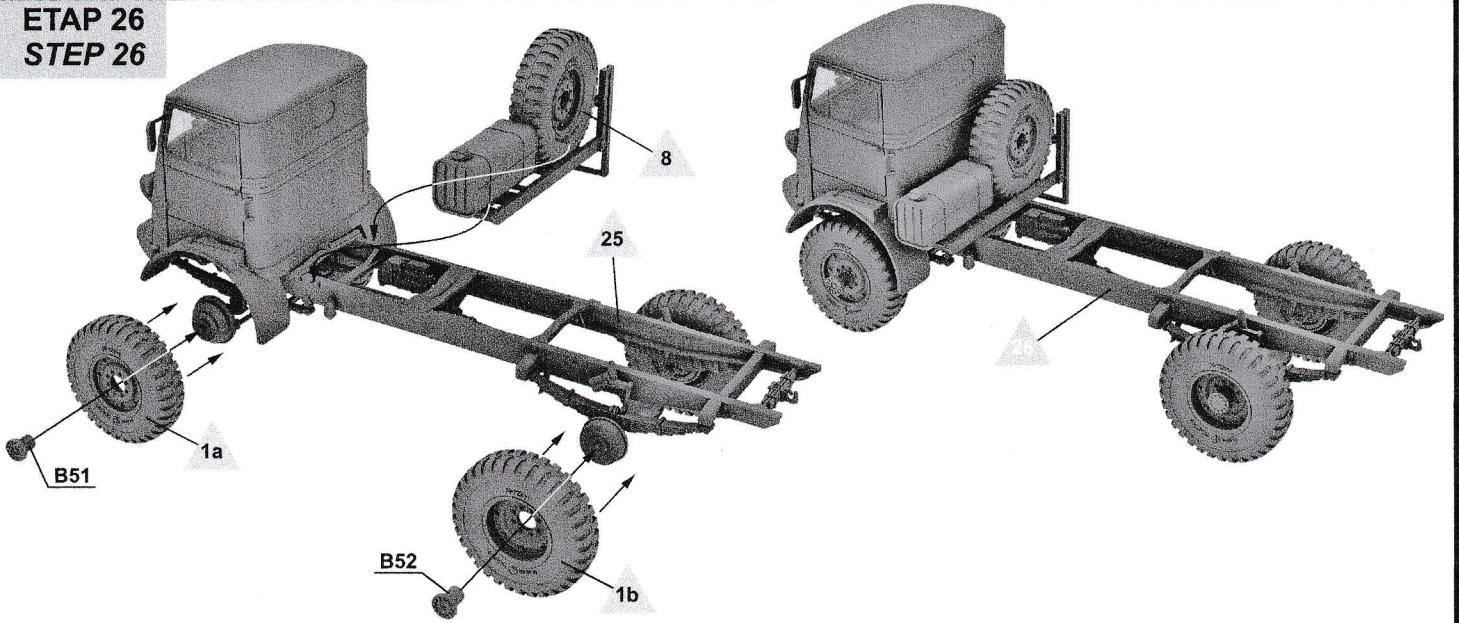

ETAP 27
STEP 27

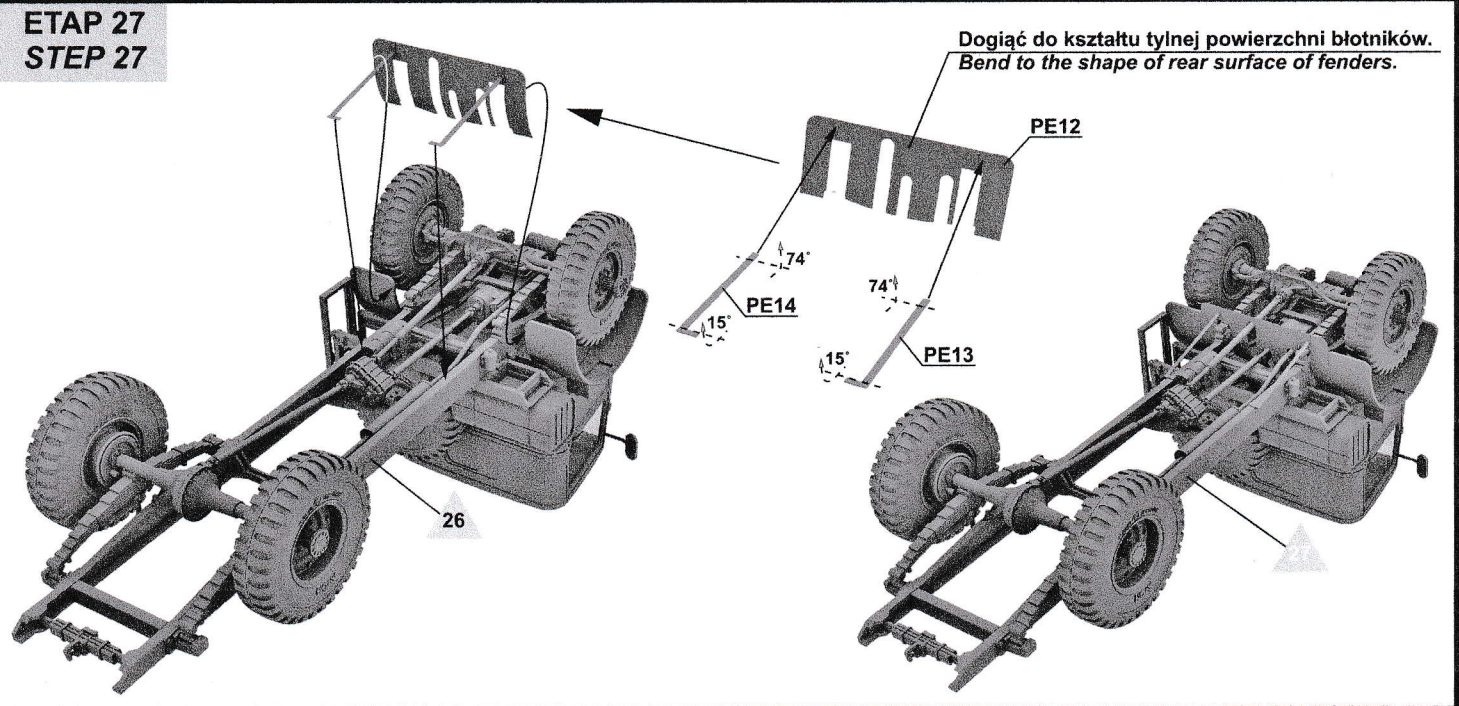

ETAP 28
STEP 28

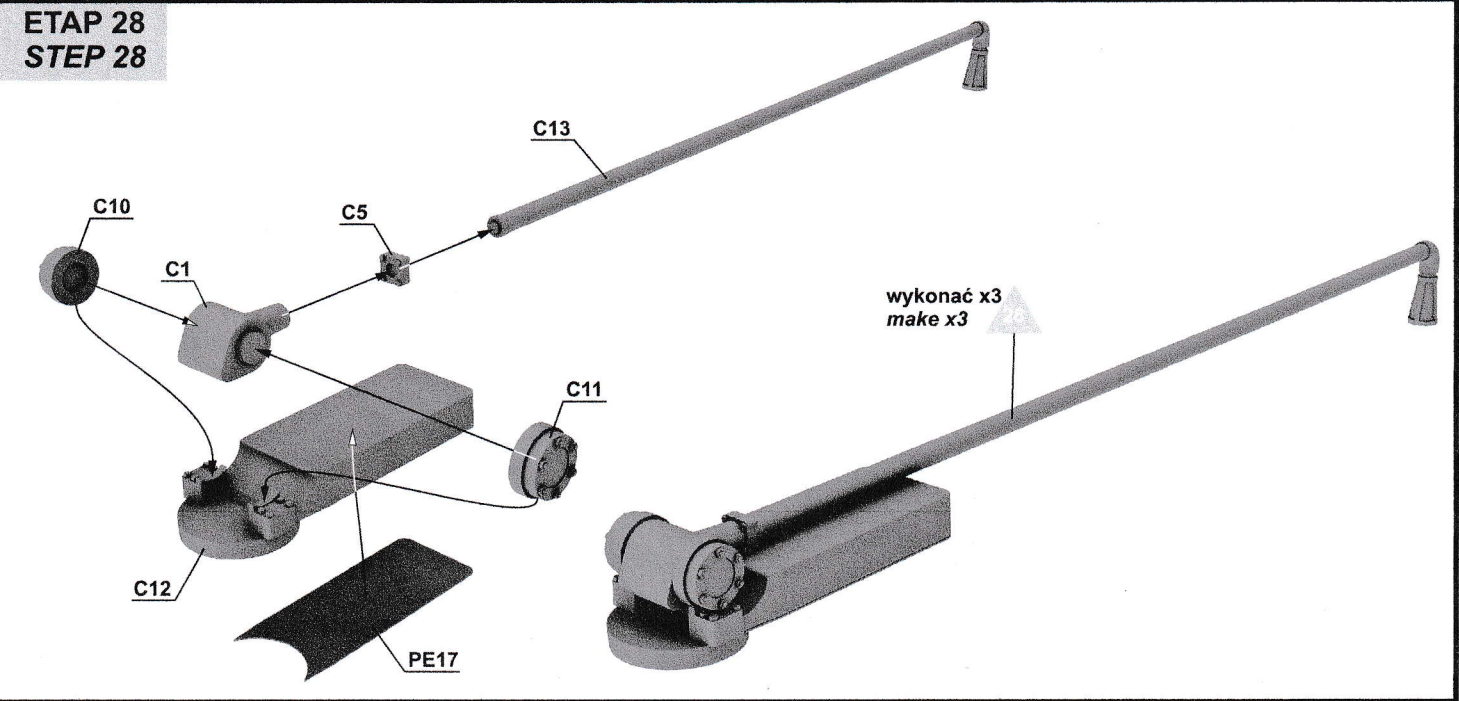

ETAP 29
STEP 29

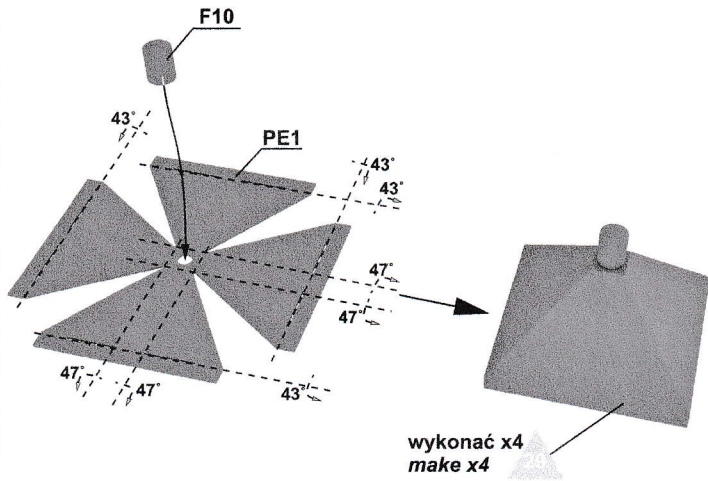

ETAP 30
STEP 30

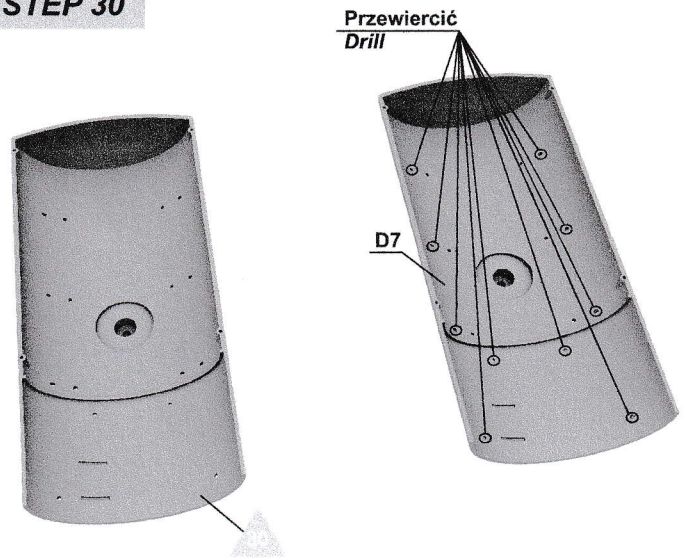

ETAP 31
STEP 31

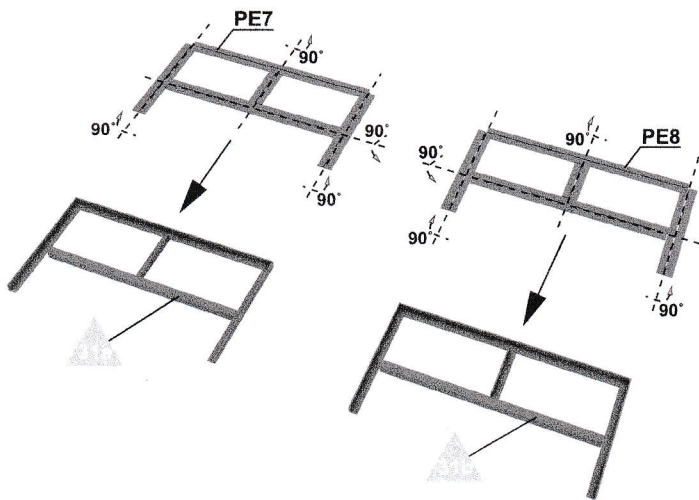

ETAP 32
STEP 32

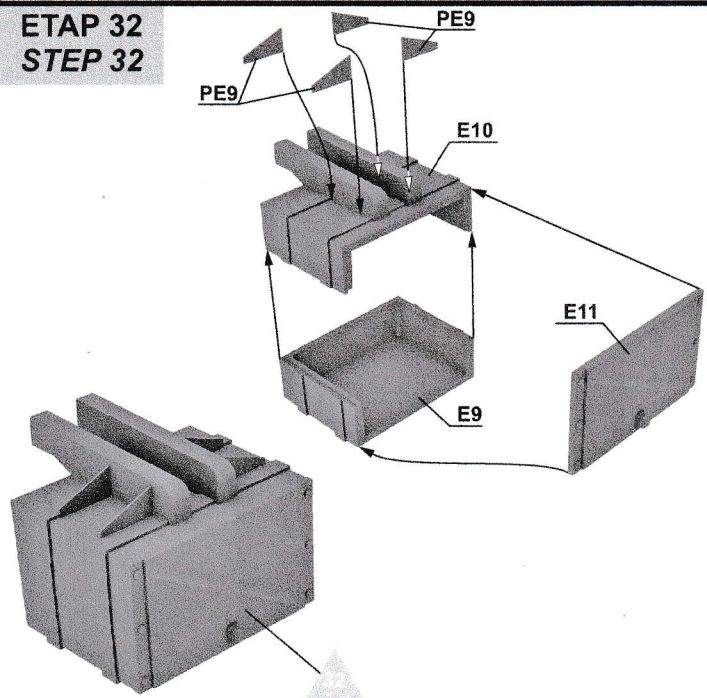

ETAP 33
STEP 33

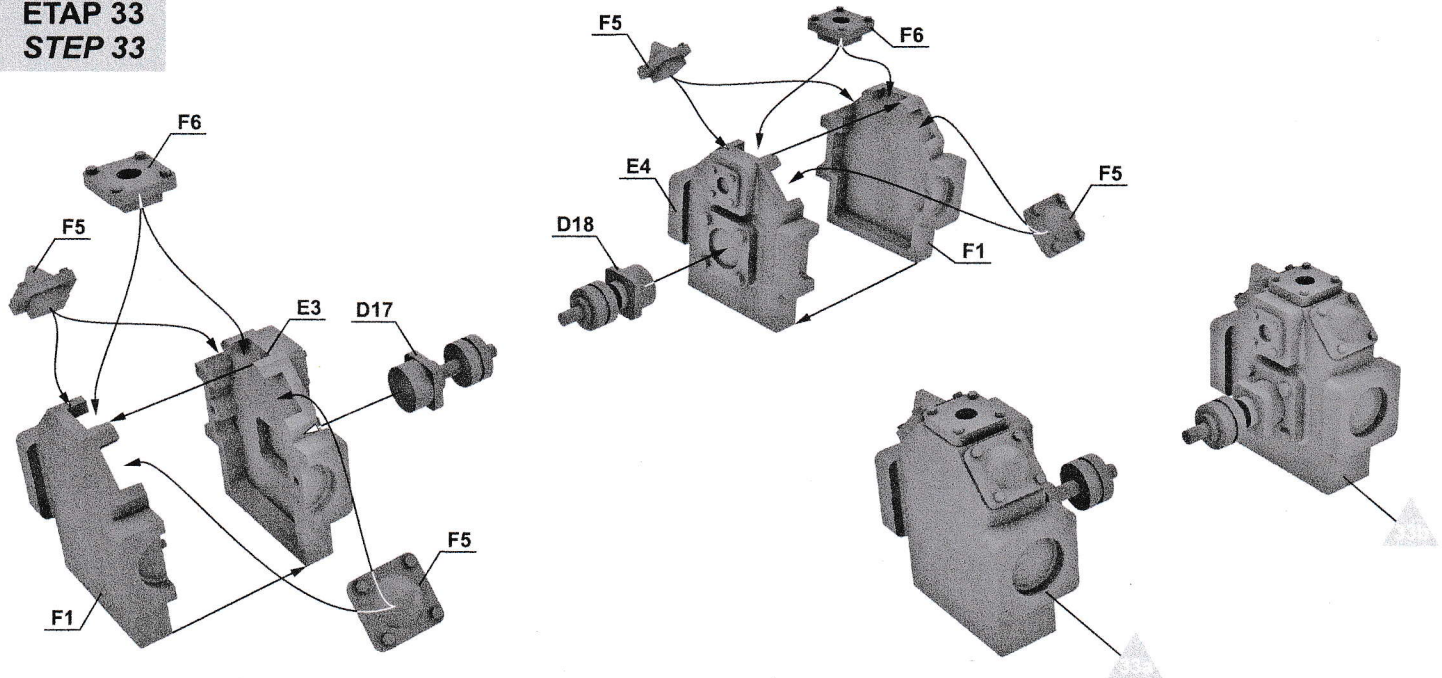

ETAP 34
STEP 34

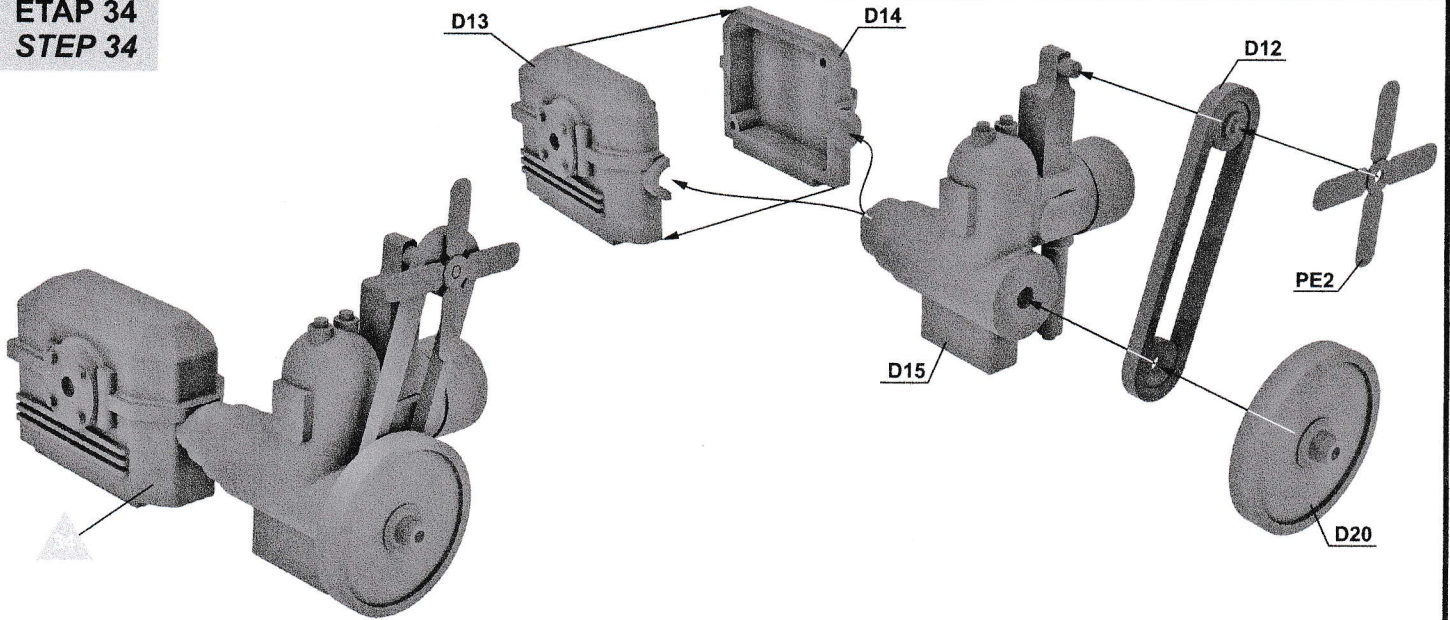

ETAP 35
STEP 35

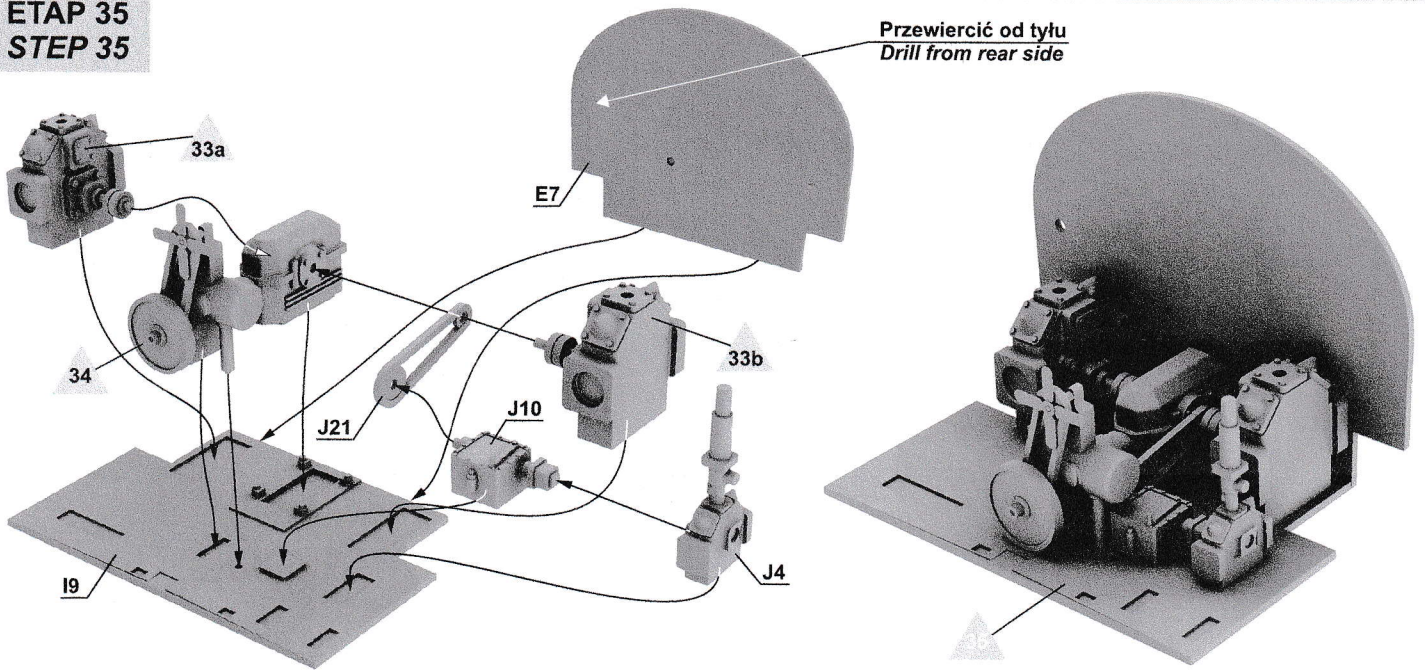

ETAP 36
STEP 36

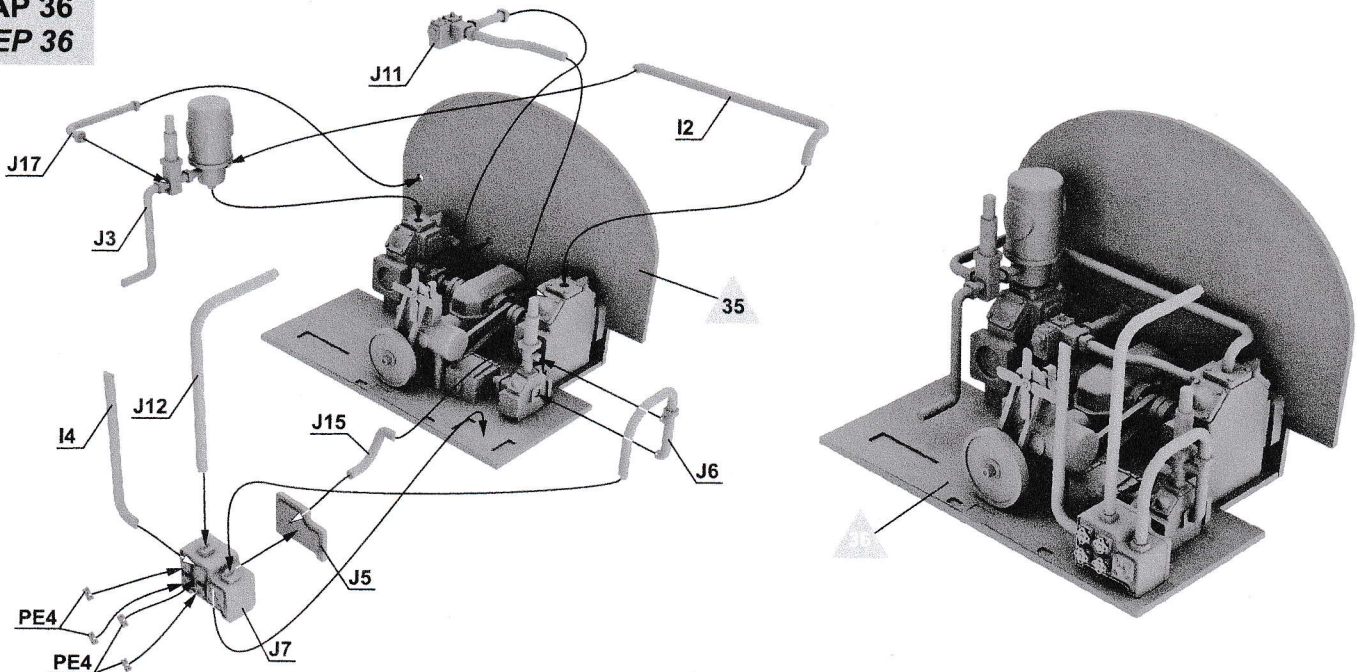

ETAP 37
STEP 37

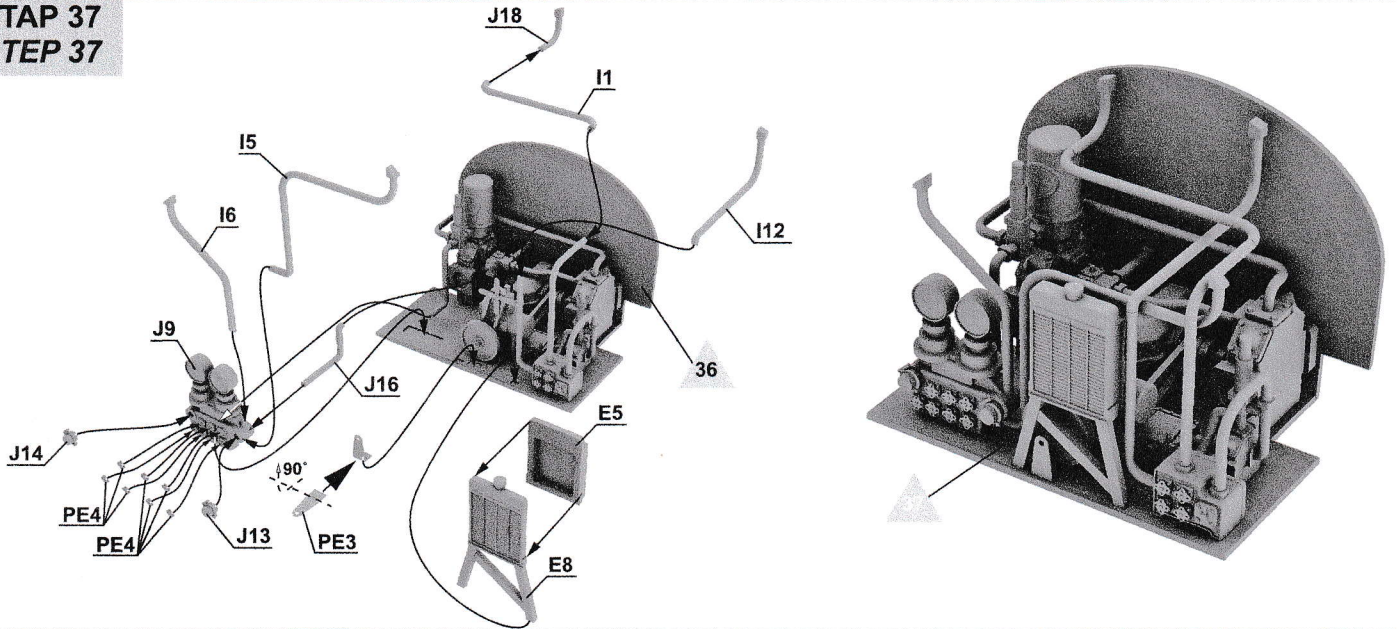

ETAP 38
STEP 38

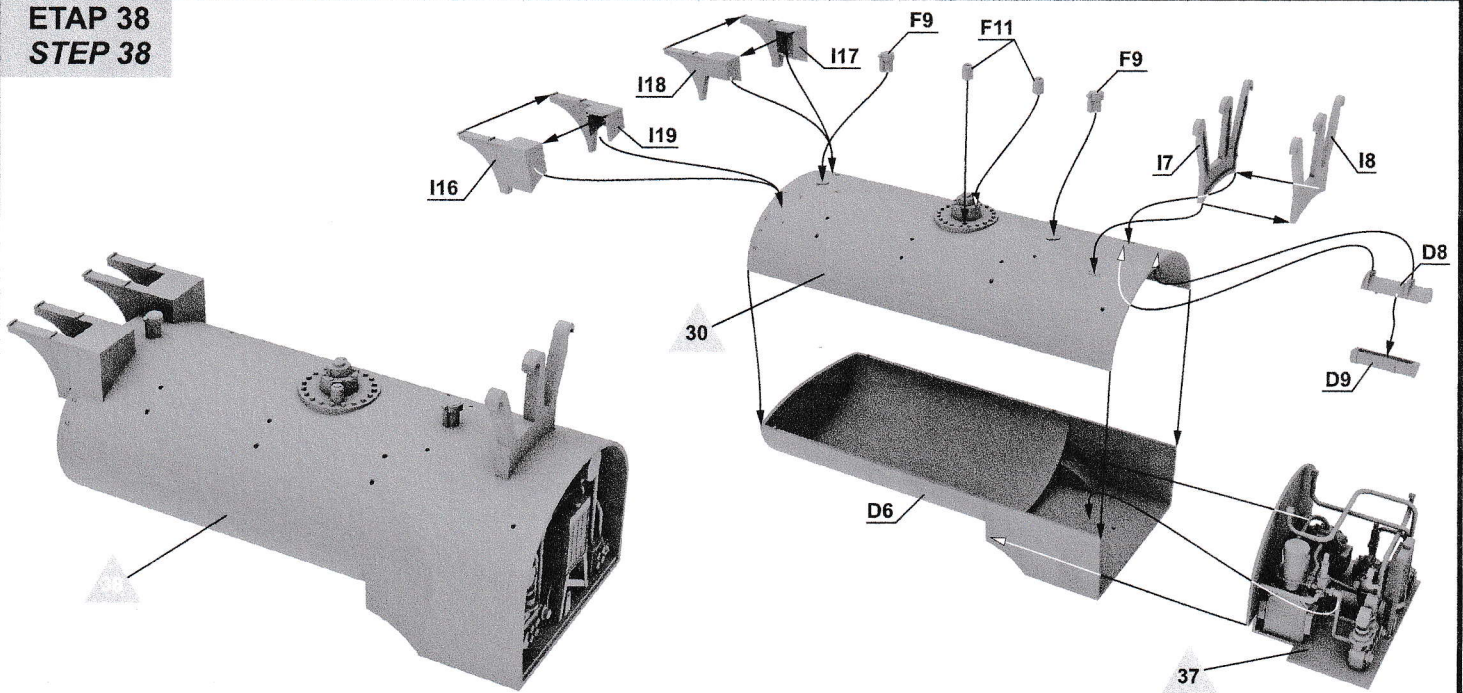

ETAP 39
STEP 39

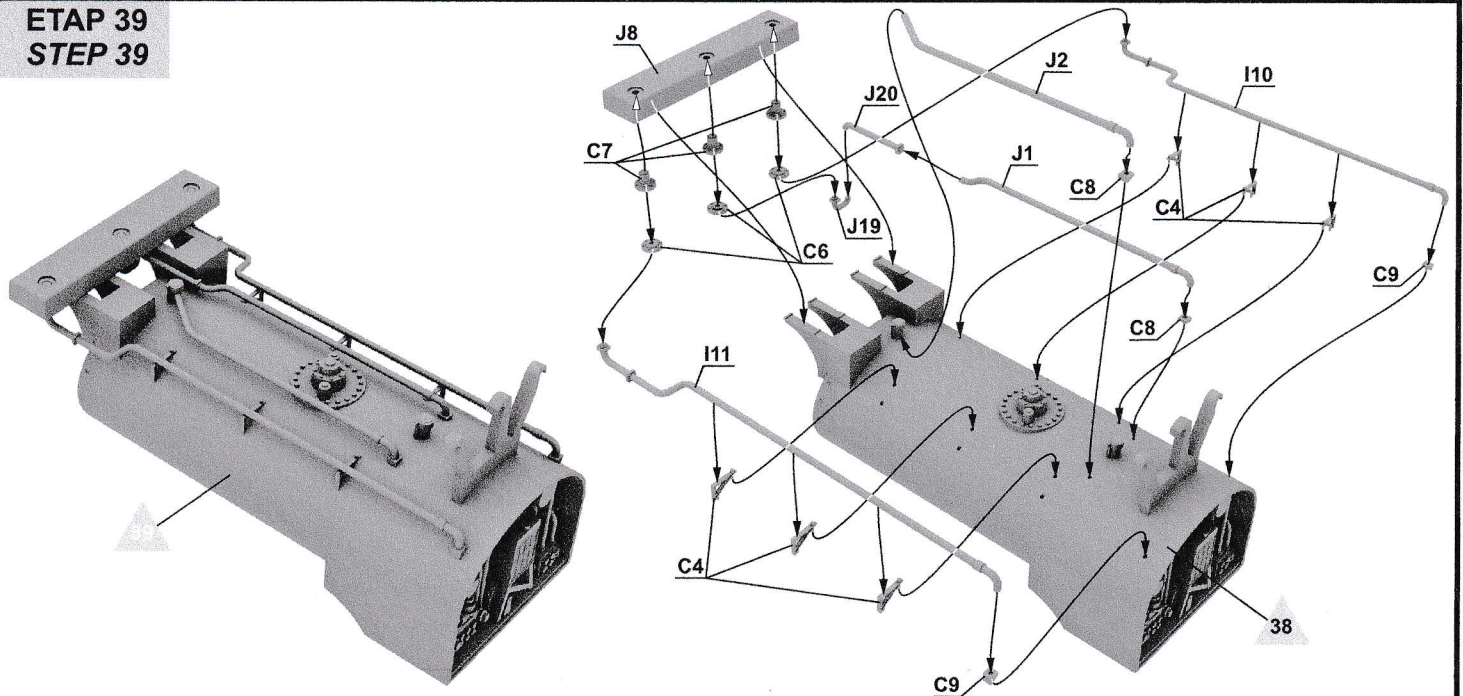

**ETAP 40
STEP 40**

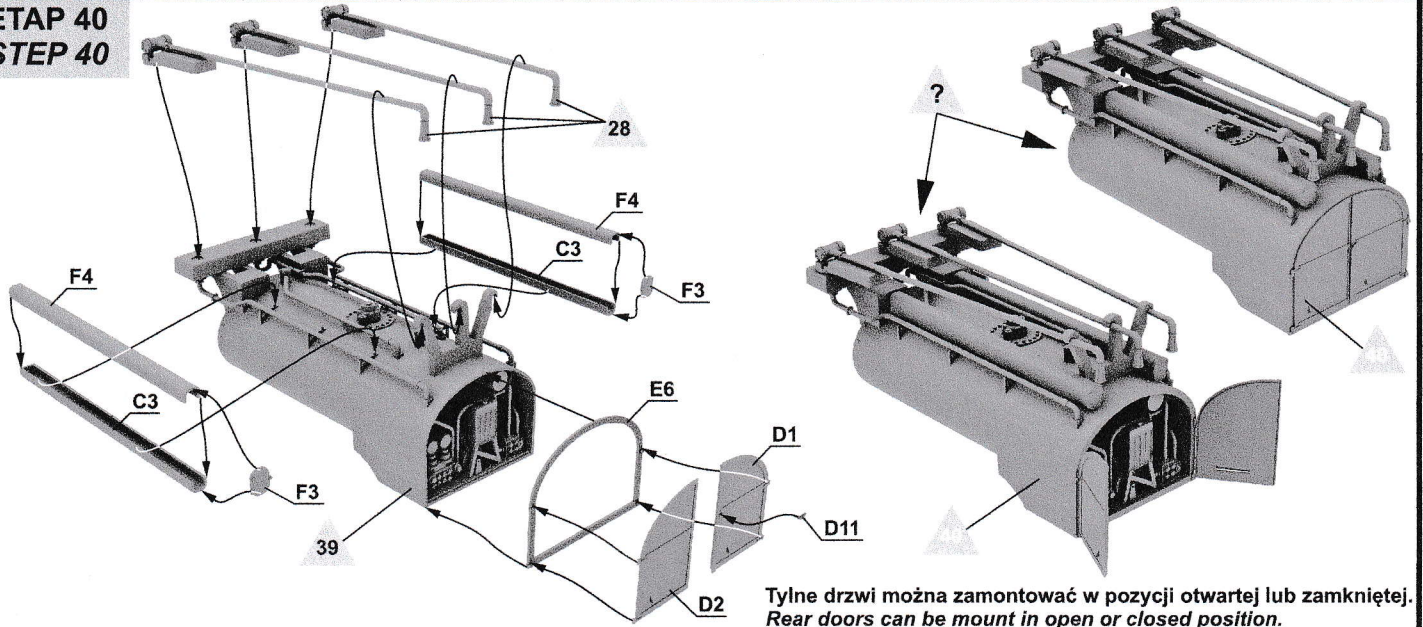

Tylnie drzwi można zamontować w pozycji otwartej lub zamkniętej.
Rear doors can be mount in open or closed position.

**ETAP 41
STEP 41**

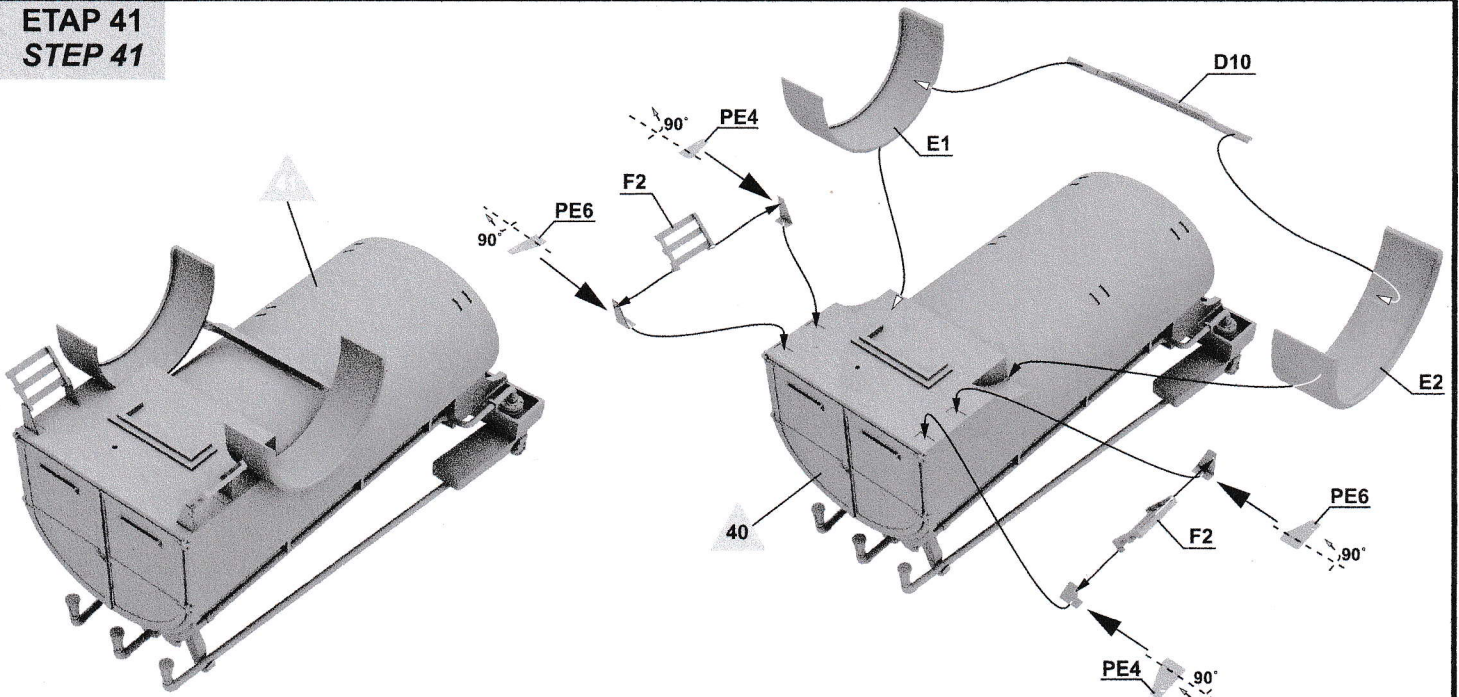

**ETAP 42
STEP 42**

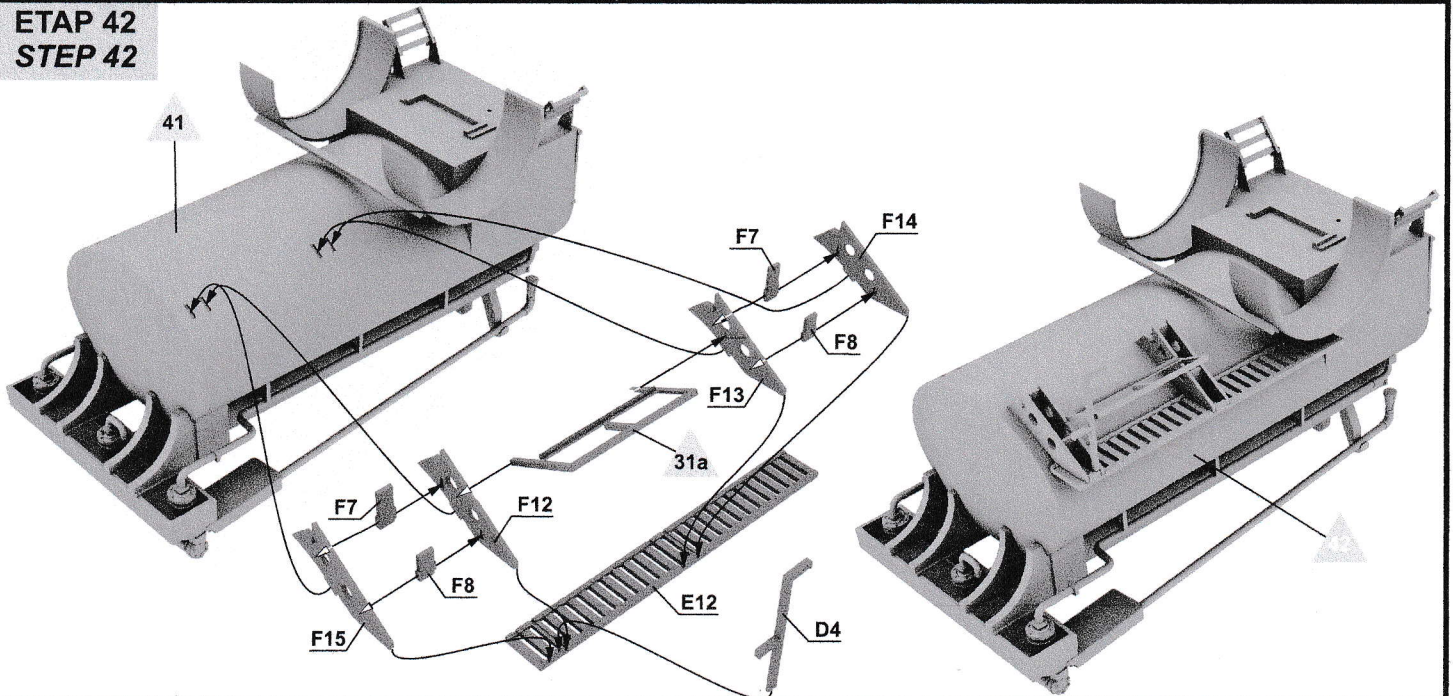

ETAP 43
STEP 43

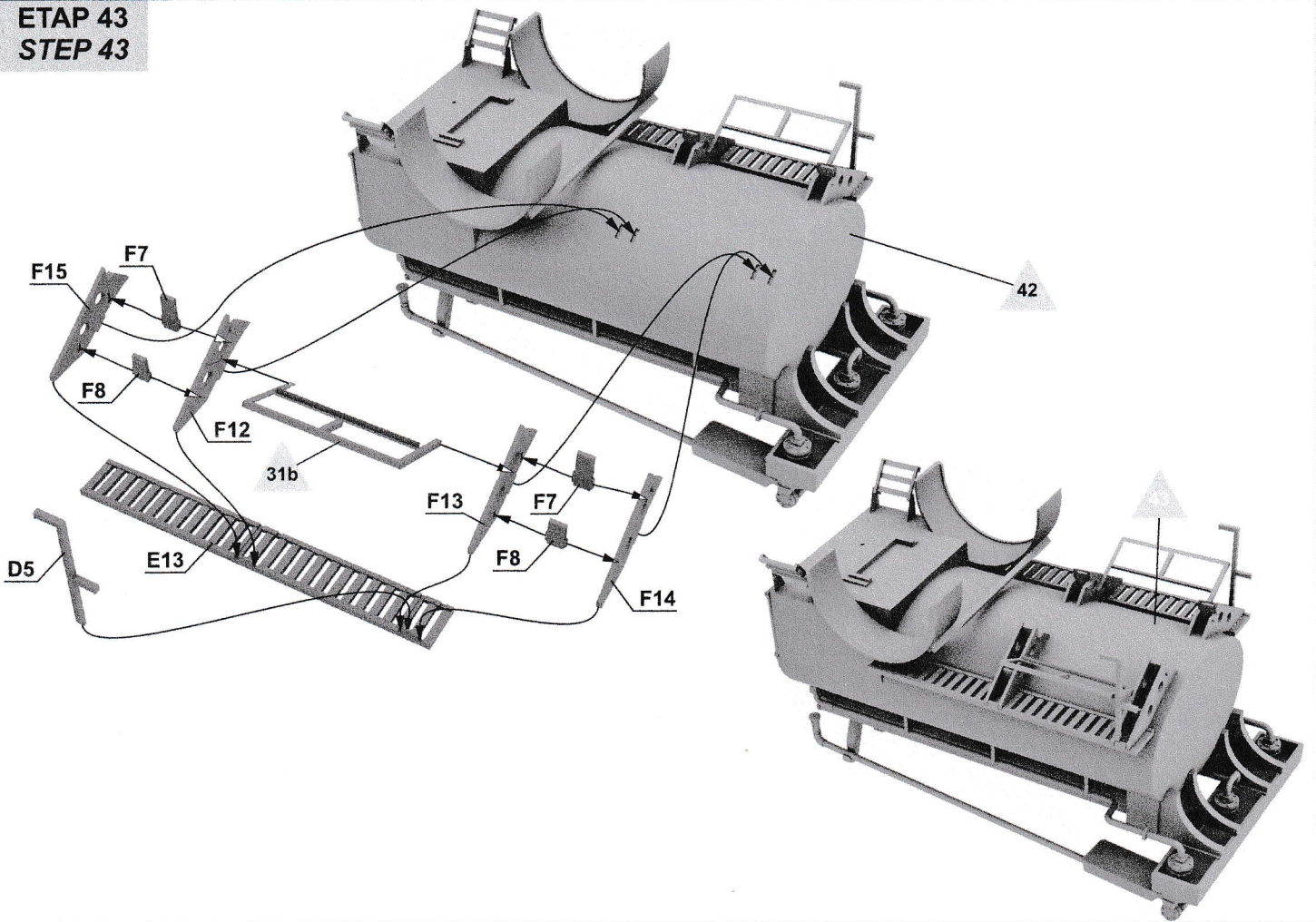

ETAP 44
STEP 44

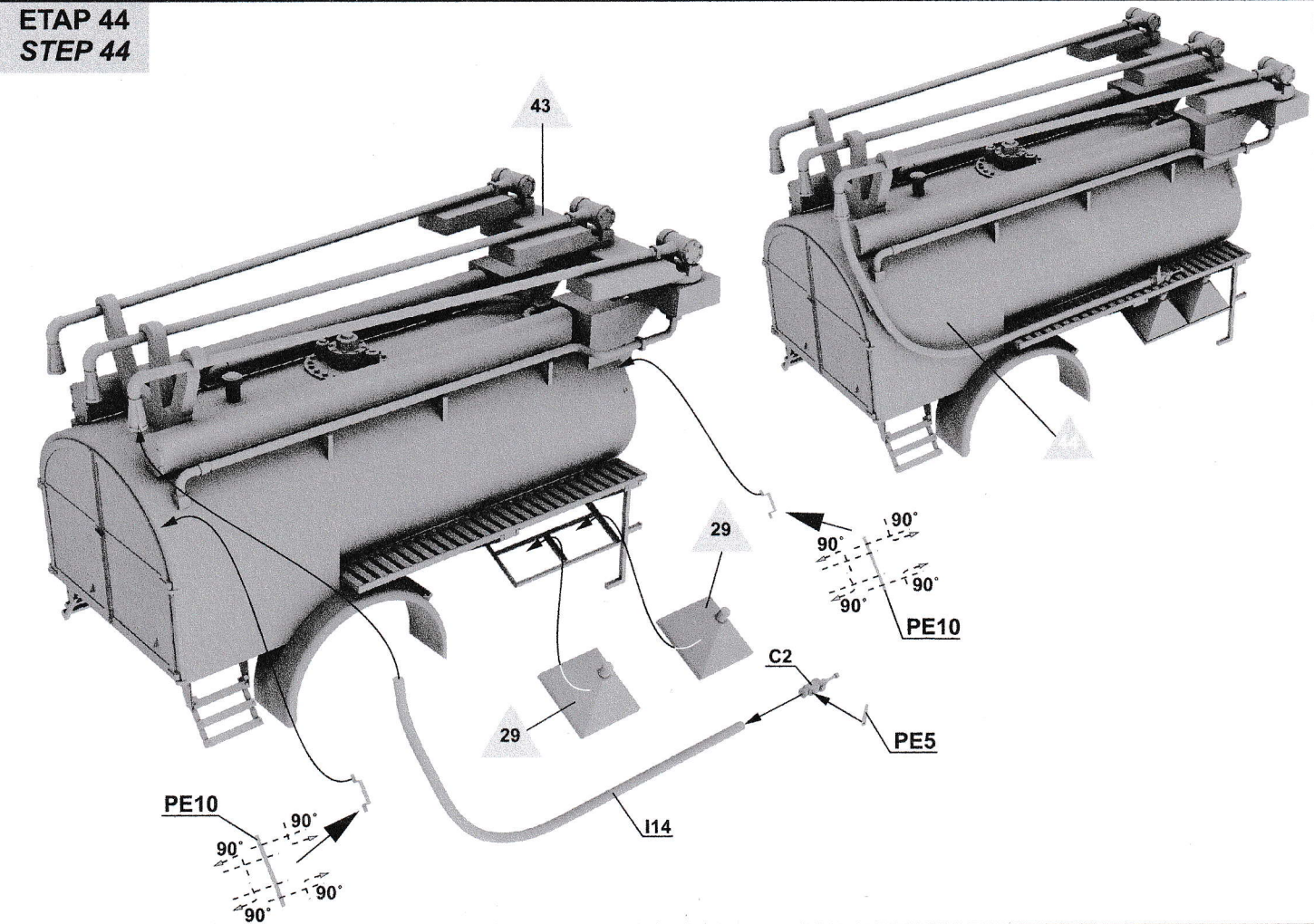

ETAP 45
STEP 45

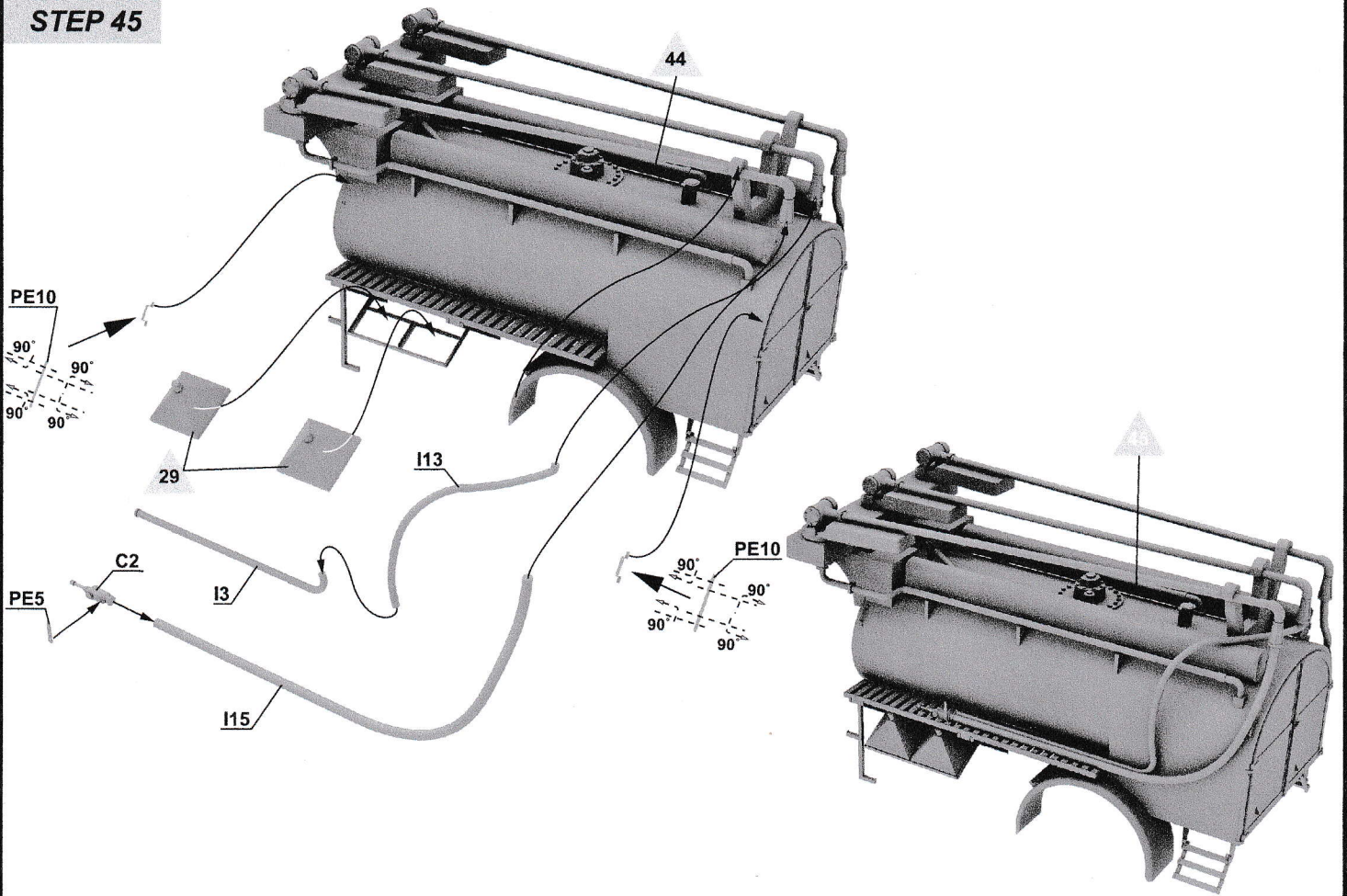

ETAP 46
STEP 46

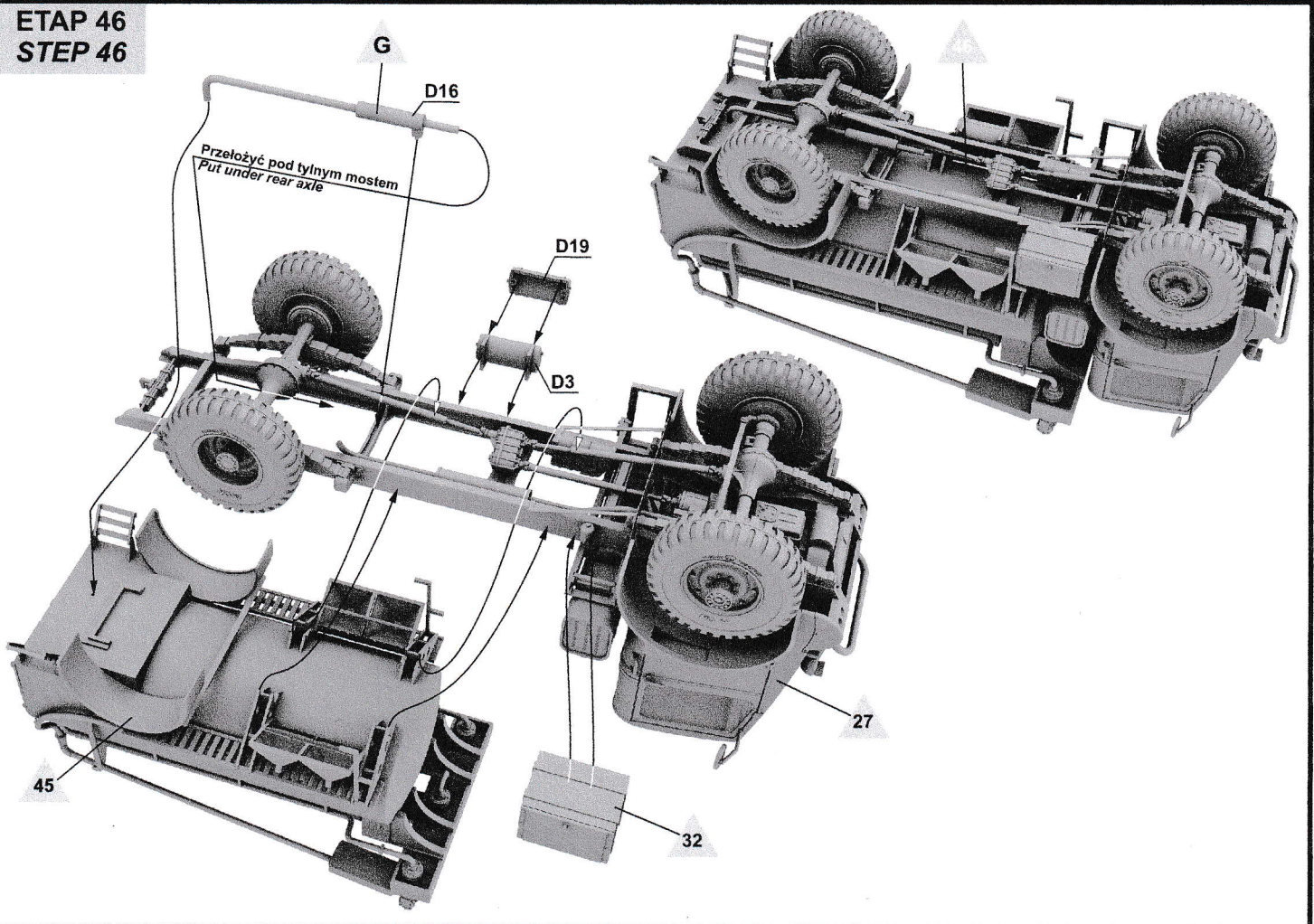

WYKONANY MODEL
FINISHED MODEL

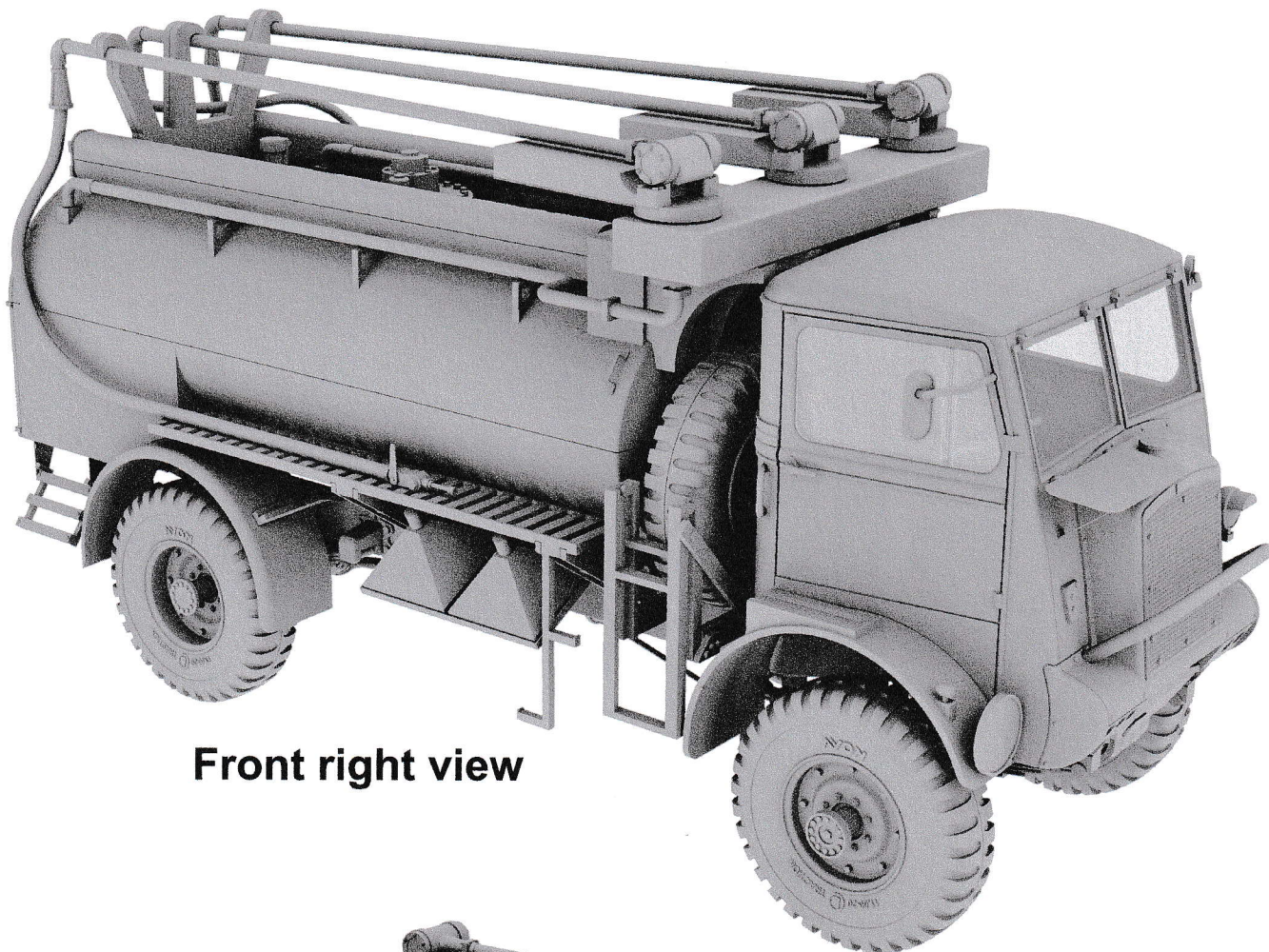

Front right view

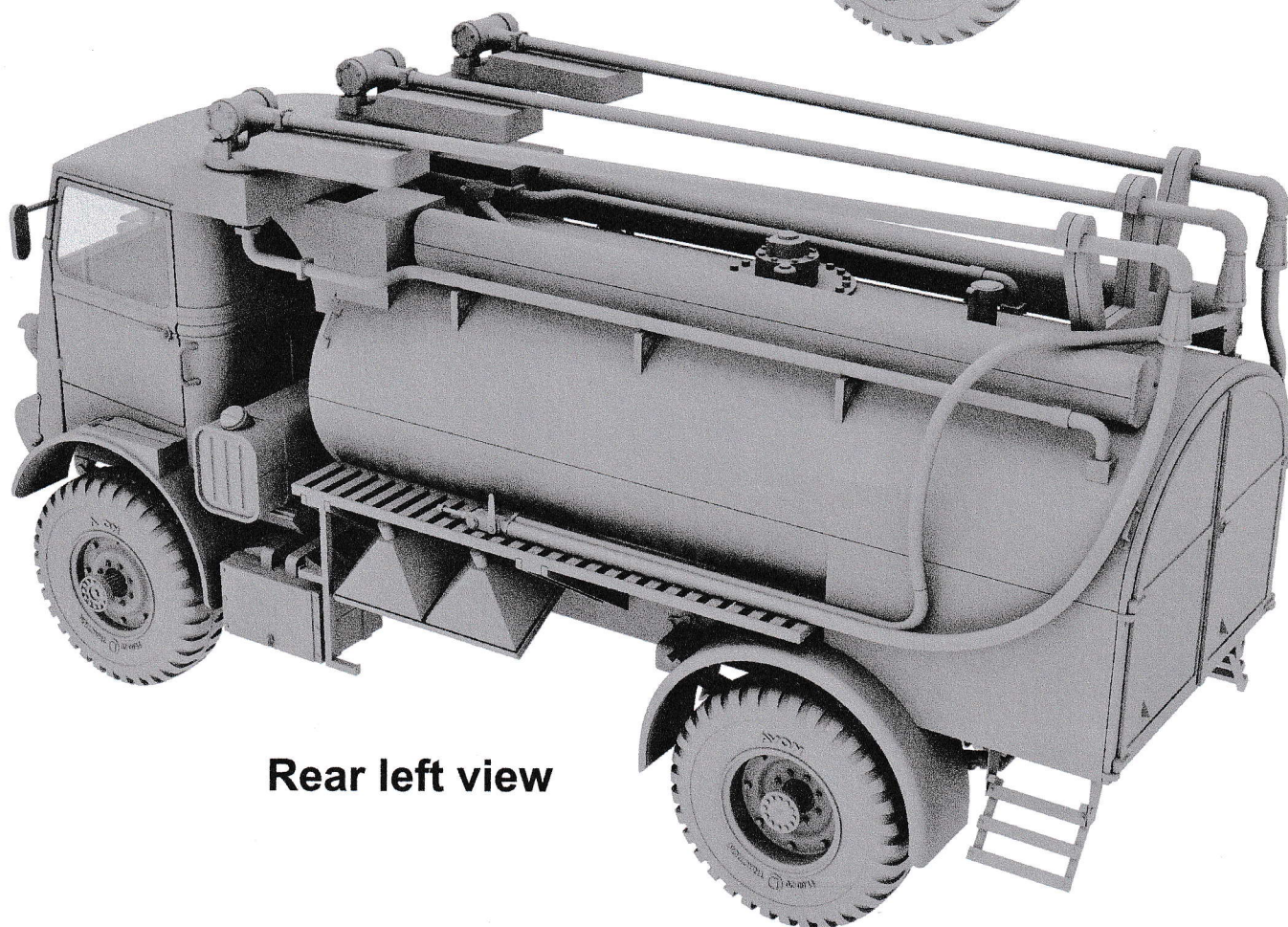

Rear left view

MALOWANIE I KALKOMANIE
COLOURS AND DECALS

RAF Bedford QL Refueller powojenny, późna wersja z bomami
17 Dywizjon Royal Air Force
Wielka Brytania, baza RAF w Chivenor, 1949
RAF Bedford QL Post-War Refueller, late version with booms
17 Squadron Royal Air Force
Great Britain, RAF base Chivenor, 1949

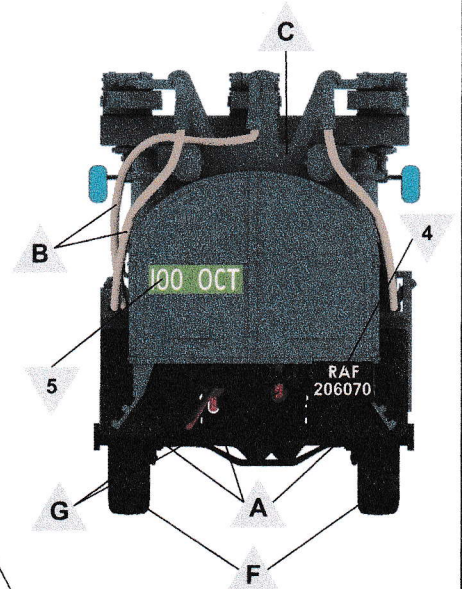
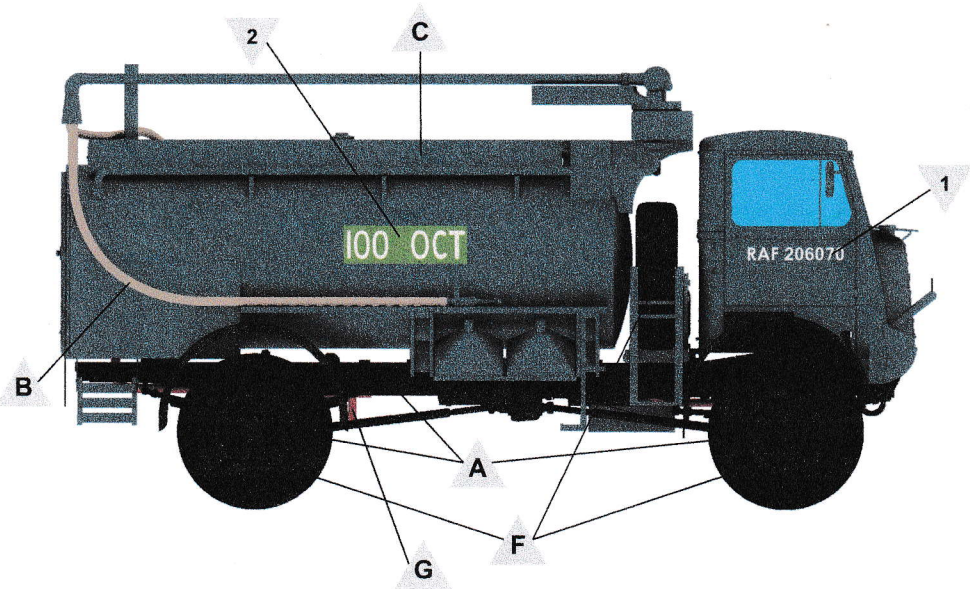
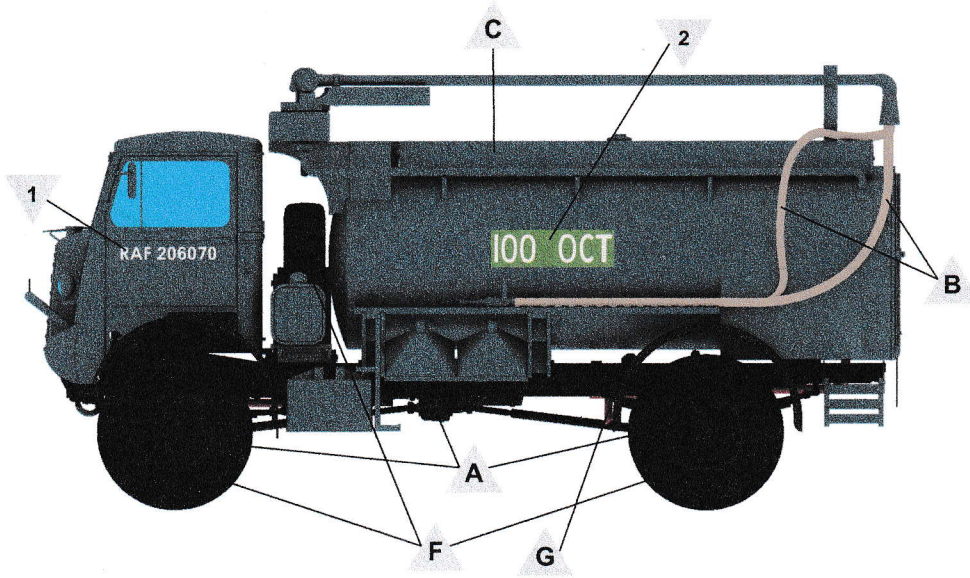

Tablice rejestracyjne nałożyć na przygotowane wcześniej płytki o wymiarach 20x4 mm i 12x8 mm.
Registration plates please apply on earlier prepared sheets with dimensions 20x4 mm & 12x8 mm.

MALOWANIE I KALKOMANIE
COLOURS AND DECALS

RAF Bedford QL Refueller powojenny, późna wersja z bomami
Niezidentyfikowana zamorska jednostka RAF, lata
pięćdziesiąte
RAF Bedford QL Post-War Refueller, late version with booms
Unidentified RAF overseas unit, 1950's

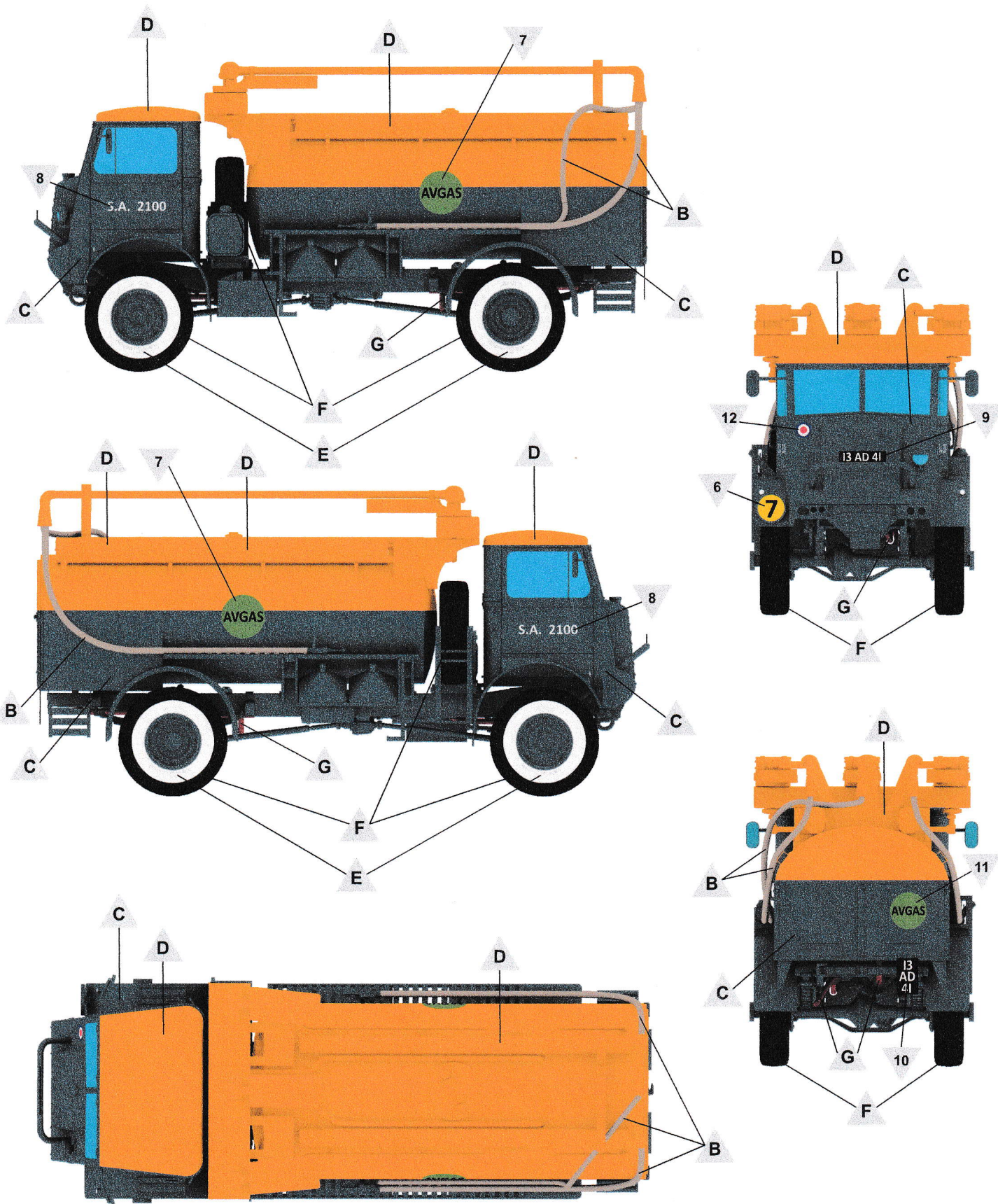

Tablice rejestracyjne nałożyć na przygotowane wcześniej płytki
o wymiarach 13x3 mm i 6x10 mm.
*Registration plates please apply on earlier prepared sheets
with dimensions 13x3 mm & 6x10 mm.*