

MIKOYAN GUREVICH

MIG-17F FRESCO C

/LIM-5 /SHENYANG J-5

INSTRUCTIONS FOR:

A.MIG-8508 MIG-17F/LIM-5, U.S.S.R.-G.D.R.

A.MIG-8509 MIG-17F/LIM-5, Poland-Cuba-Angola

A.MIG-8510 MIG-17F Shenyang J-5, Vietnam-China-North Korea

A.MIG-8511 MIG-17F, Egypt-Syria

A.MIG-8512 MIG-17F/LIM-5, U.S.S.R.-G.D.R. Premium Edition

A.MIG-8513 MIG-17F/LIM-5, Poland-Cuba-Angola Premium Edition

A.MIG-8514 MIG-17F Shenyang J-5, Vietnam-China-North Korea Premium Edition

A.MIG-8515 MIG-17F, Egypt-Syria Premium Edition

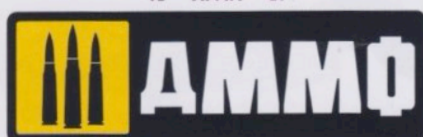
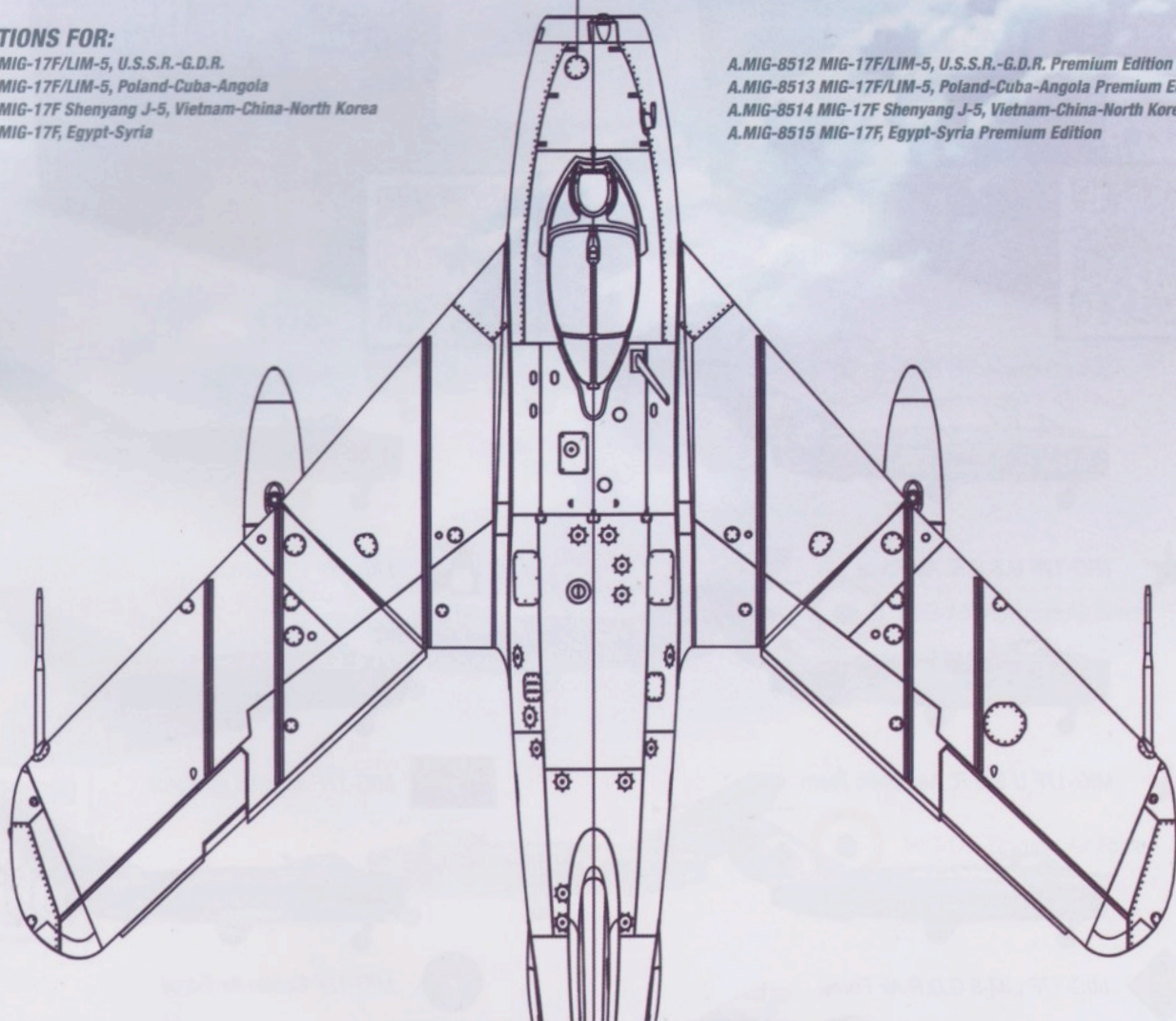

by **MIG Jimenez**

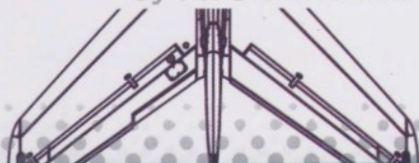

MIKOYAN GUREVICH MIG-17F FRESCO C

The Mikoyan-Gurevich MiG-17 was one of the legendary post-war Soviet fighters. It was the second Soviet-produced jet fighter after the MiG-15, and predated other mythical Soviet fighters such as the MiG-19 and MiG-21. The overall design was based on the MiG-15 and featured new wing, a 20% longer fuselage, and a more powerful VK-1 engine which incorporated an afterburner with the F version.

The MiG-17 entered service in 1951 with the initial model MiG-17A (NATO reporting name: Fresco A); and just two years later in 1953, the MiG-17B (Fresco B) was already in operation. Next was the most widespread and well-known variant, the MiG-17F (Fresco C), began to enter service.

The MiG-17 is one of the most iconic aircraft of the Cold War. It is also one of the most numerous-produced military aircraft in history and used by a larger number of countries than any other. Besides the Soviet Union, it was also manufactured under license in Poland as the Lim-5, and in China under the designation Shenyang J-5.

This kit could not have been made without the collaboration of Laurent Stern and Vinicius Pompeo.



MIG-17F U.S.S.R. Air Force



MIG-17F U.S.S.R. Aerobatic Team



MIG-17F LIM-5 G.D.R. Air Force



MIG-17F LIM-5 G.D.R. Air Force



MIG-17F LIM-5 Polish Air Force



MIG-17F Angolan Air Force



MIG-17F Cuban Air Force



 MIG-17F Shenyang J-5
North Vietnamese Air Force



 MIG-17F Shenyang J-5
North Vietnamese Air Force



 MIG-17F Shenyang J-5
People's Liberation Army Air Force



 MIG-17F Shenyang J-5
People's Liberation Army Air Force



 MIG-17F Shenyang J-5
Korean People's Air Force





 MIG-17F Egyptian Air Force



 MIG-17F Egyptian Air Force



 MIG-17F Syrian Air Force



READ THIS BEFORE BEGINNING YOUR MODEL!

1. This scale model is intended for hobbyists 14 years and older.
2. Carefully read all instructions for this kit and suggested finishing and painting products (not included with this product) before you begin assembly of this scale model.
3. Adult supervision may be required when using hobby knives, abrasives, and any tools not included with this kit during assembly.
4. This kit includes small parts and plastic bags that can be a dangerous choking hazard. Keep out of reach of children.

ICONS



DRILL REMOVE x2 SET OPTIONAL USE SLOW DRY USE INSTANT DRY NOT GLUE ULTRA GLUE BEND

HOW TO ASSEMBLE THIS KIT

Carefully read the instructions for each step before beginning the assembly.

- Separate the kit pieces from the sprue using a blade while resting the sprue on a cutting board. Remove the remaining sprue with a fine file.
- Dry fit and test for proper alignment of photoetched pieces before applying Slow Dry Cyanoacrylate A.MIG-8013 which offers the necessary work time for accurate placement. Lightly sand the contact surface of the parts to be joined to improve adhesion. For assembly of plastic parts, use Black Slow Dry Cyanoacrylate A.MIG-8034 which allows you to easily see correctable flaws. Dry time can be rapidly increased using Activator A.MIG-8037 used to accelerate cyanoacrylate dry time.
- Permanently join plastic pieces with styrene glue Extra Thin Cement A.MIG-2025 or Medium Dense Cement A.MIG-2039.
- For the assembly of pieces that require some flexibility such as tool clamp supports and handles, we recommend using Ultra Glue A.MIG-2031 to create joints more resilient to manipulation and handling during assembly.
- For simple corrections, use Arming Putty Acrylic type A.MIG-2039 or Arming Putty Classic A.MIG-2040 to level any gap or step between pieces. Let the putty dry and level the area with fine files and sandpaper.



PARTS

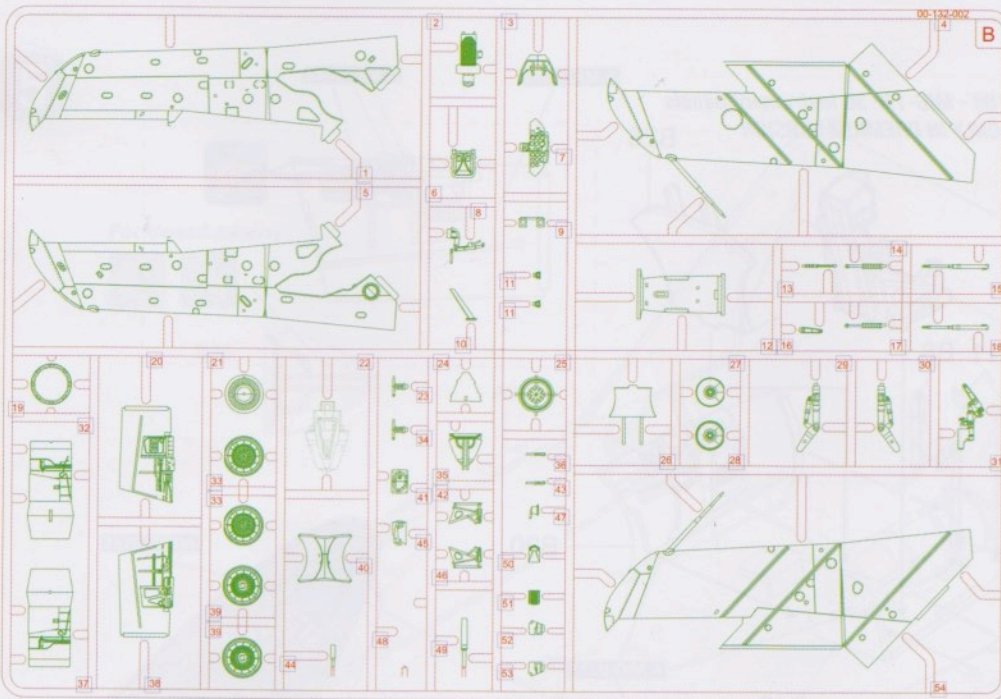
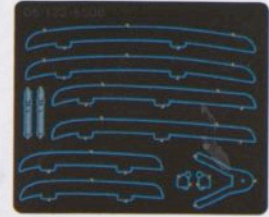
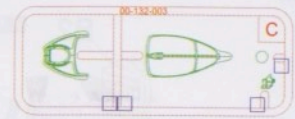
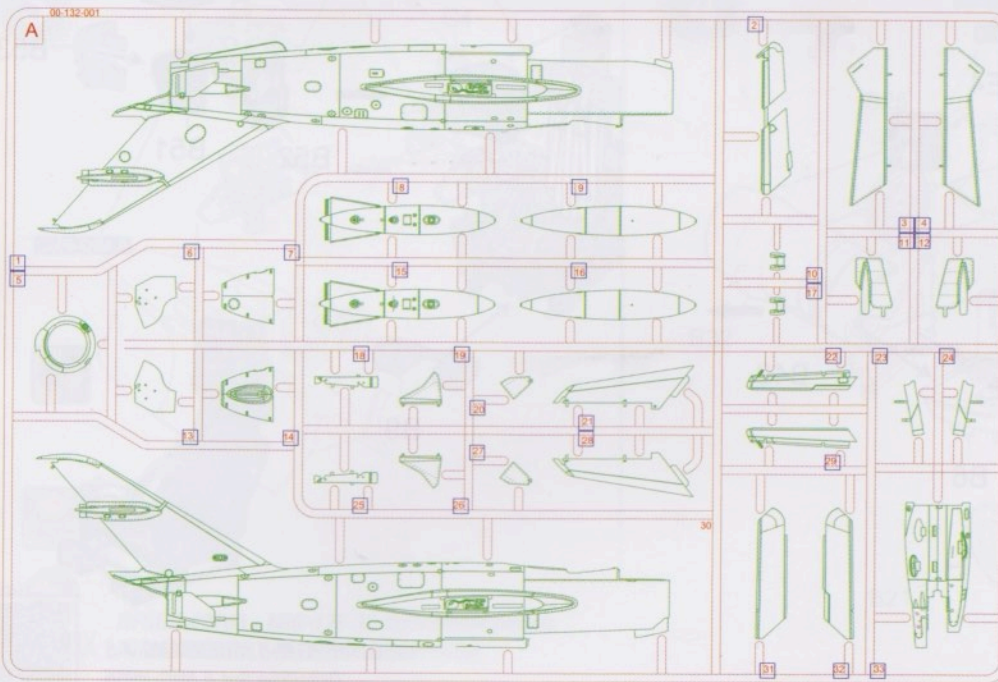

AMMO COLORS

A.MIG-2318 A-STAND AIRFRAME ALUMINIUM
 A.MIG-2302 A-STAND DARK ALUMINIUM
 A.MIG-2310 A-STAND MAGNESIUM
 A.MIG-2316 A-STAND DULL ALUMINIUM
 A.MIG-2306 A-STAND CHROME FOR PLASTIC

A.MIG-0032 SATIN BLACK
 A.MIG-0054 SIGNAL GREEN
 A.MIG-0271 AIR SUPERIORITY BLUE
 A.MIG-0046 MATT BLACK
 A.MIG-0195 SILVER
 A.MIG-0033 RUBBER & TIRES
 A.MIG-0093 CRYSTAL RED

A.MIG-0092 CRYSTAL GREEN
 A.MIG-0206 DARK GREEN
 A.MIG-0076 RED BROWN
 A.MIG-0128 LIGHT BLUE
 A.MIG-0049 RED
 A.MIG-0103 MEDIUM BLUE
 A.MIG-0223 TURQUOISE GREEN

1

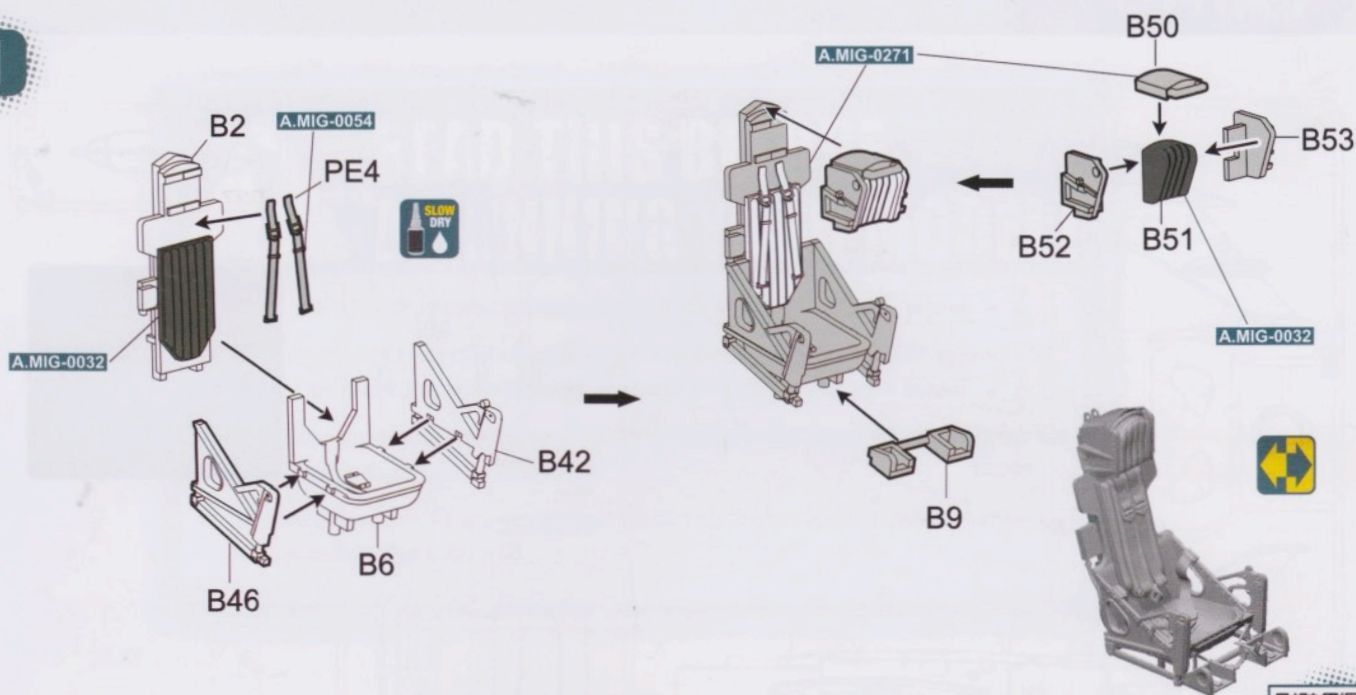

MIG-17F / LIM-5 / SHENYANG J-5
Detailing Set A.MIG-8955



2



RFSQS-48186 - MIG-17F 3D Instrument panels
INCLUDED ONLY IN PREMIUM VERSION

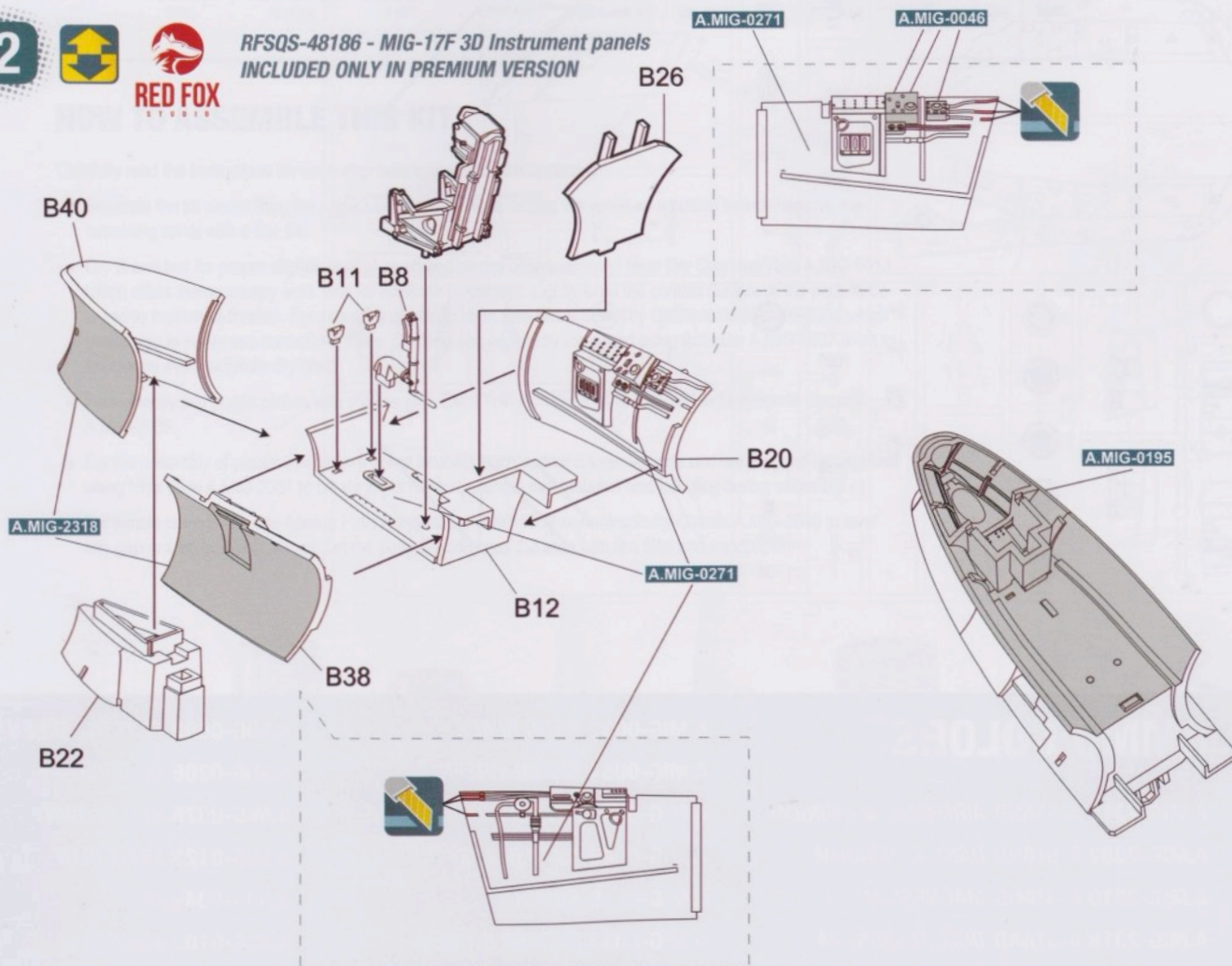

3

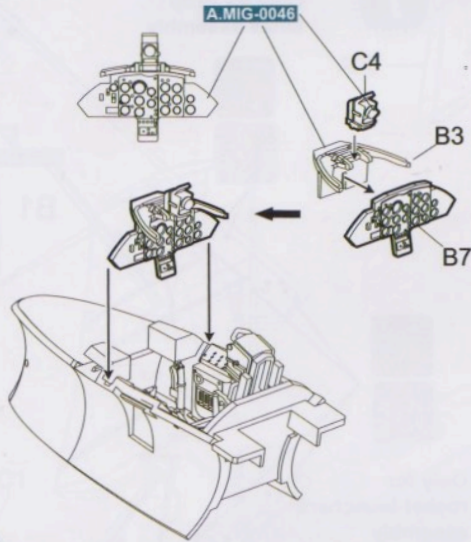

4

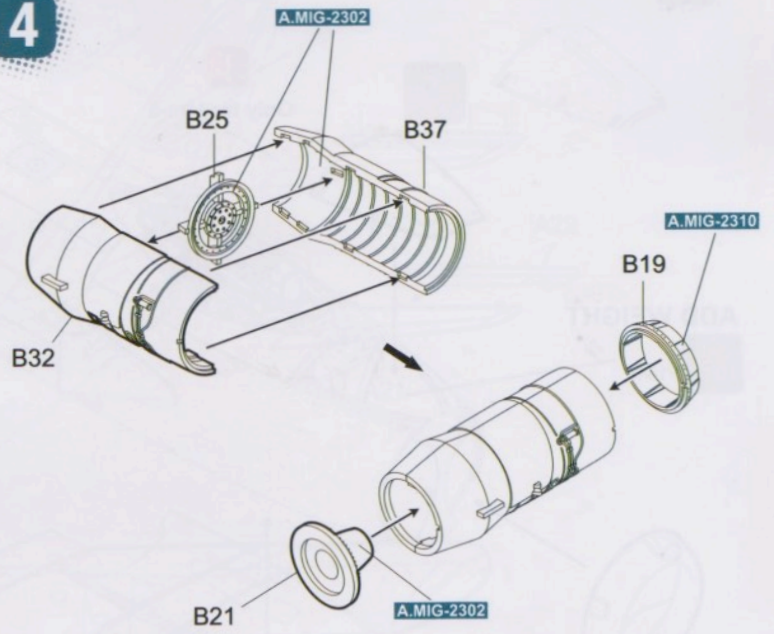

RED FOX

RFSQS-48186 - MIG-17F 3D Instrument panels
INCLUDED ONLY IN PREMIUM VERSION

5

For closed canopy

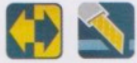

B35

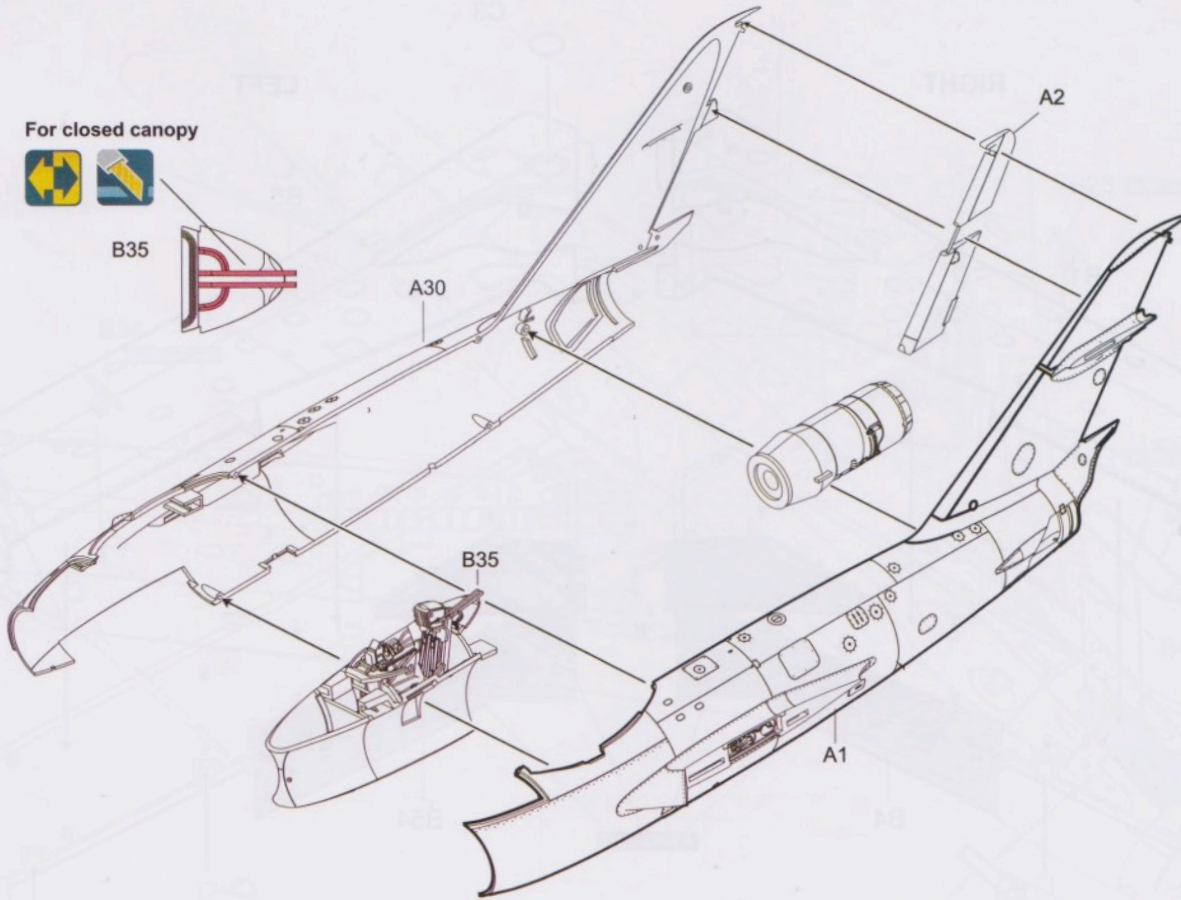

6

A14



Only for Lim-5

A7

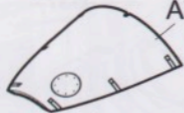

ADD WEIGHT



/15ml



A5

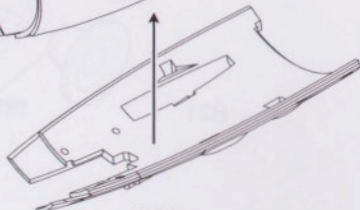

A33

7

Only for drop tanks assembly



B1



Only for rocket-launchers assembly



Only for drop tanks assembly

B5

RIGHT

LEFT

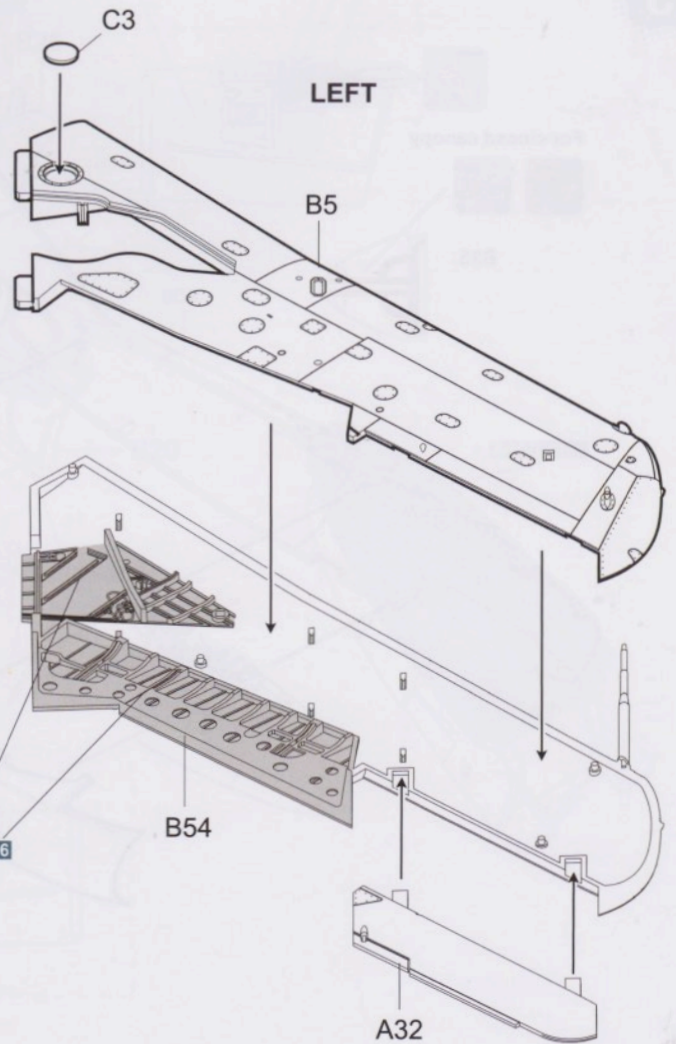
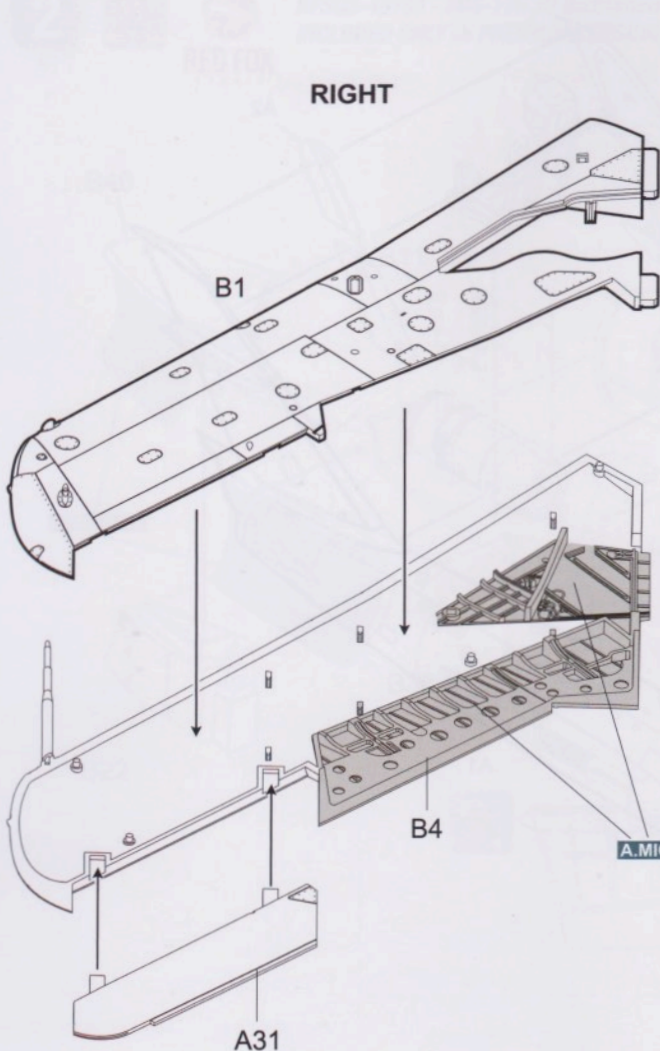

A.MIG-2316

8

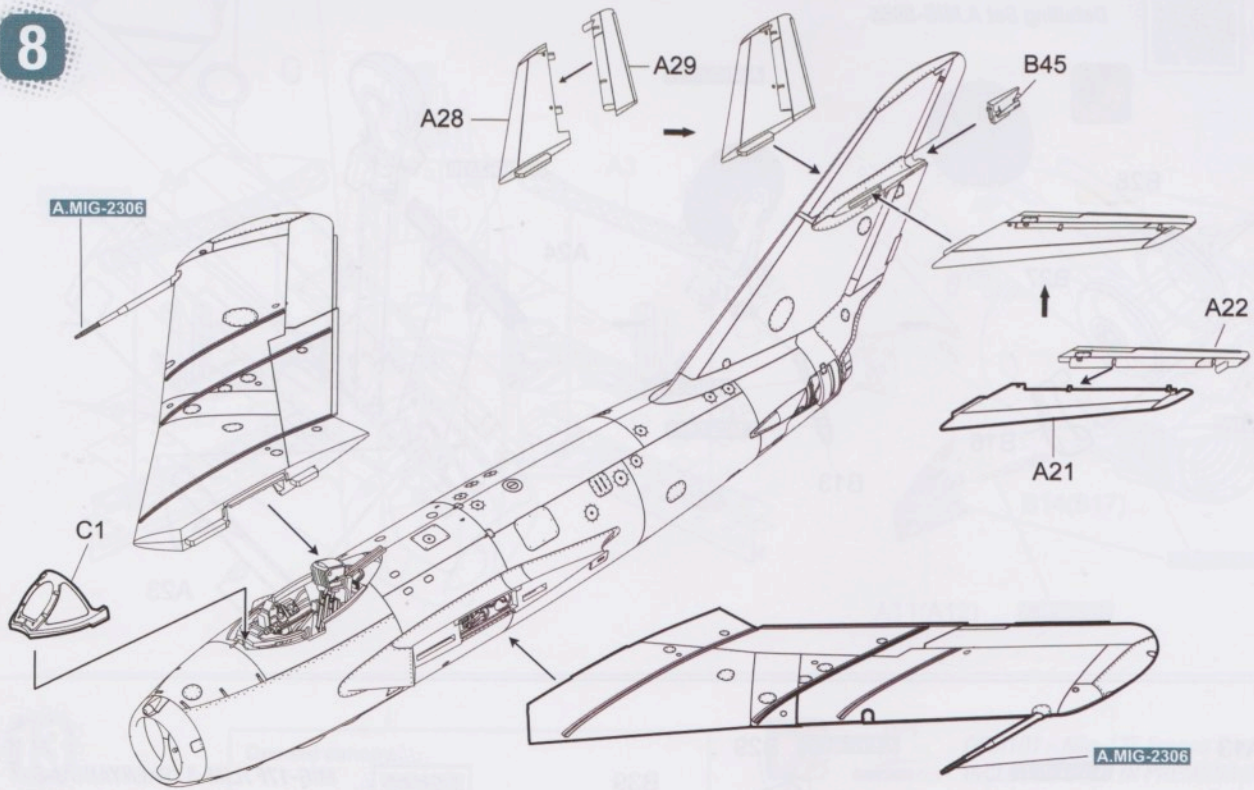

9



10



MIG-17F / LIM-5 / SHENYANG J-5
Detailing Set A.MIG-8955

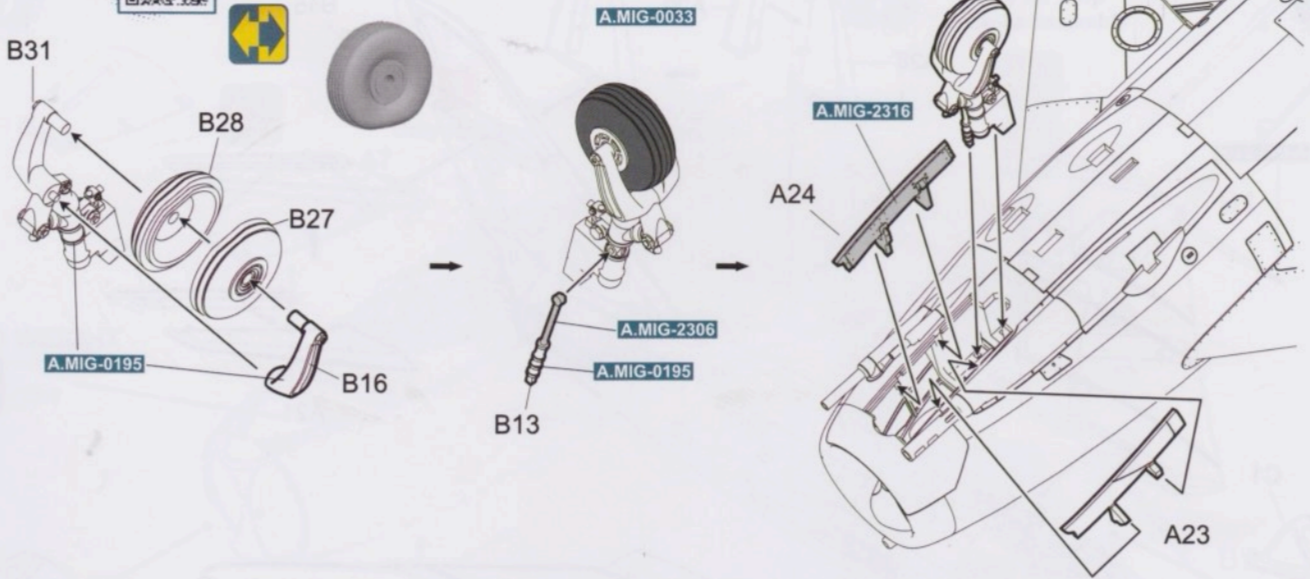

11



MIG-17F / LIM-5 / SHENYANG J-5
Detailing Set A.MIG-8955

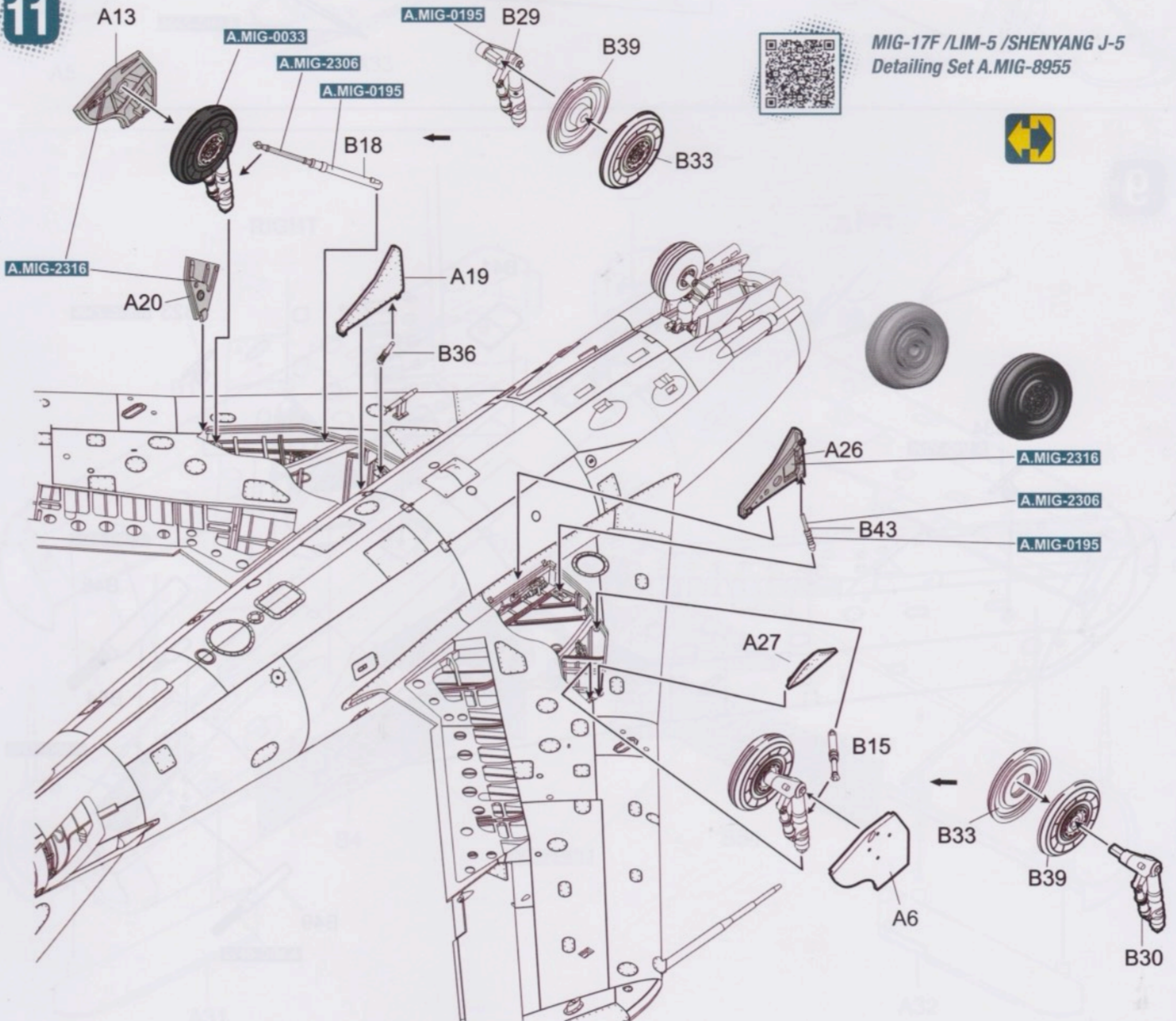

12

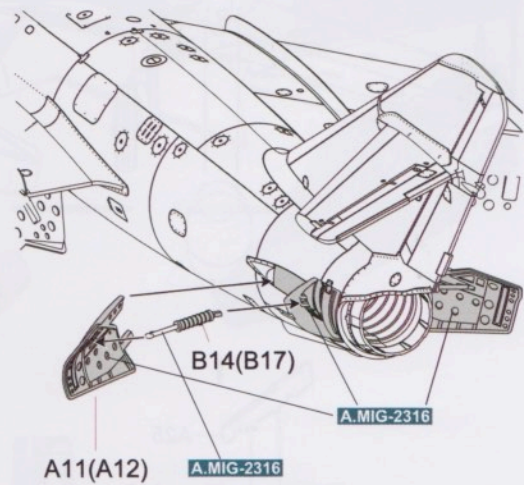
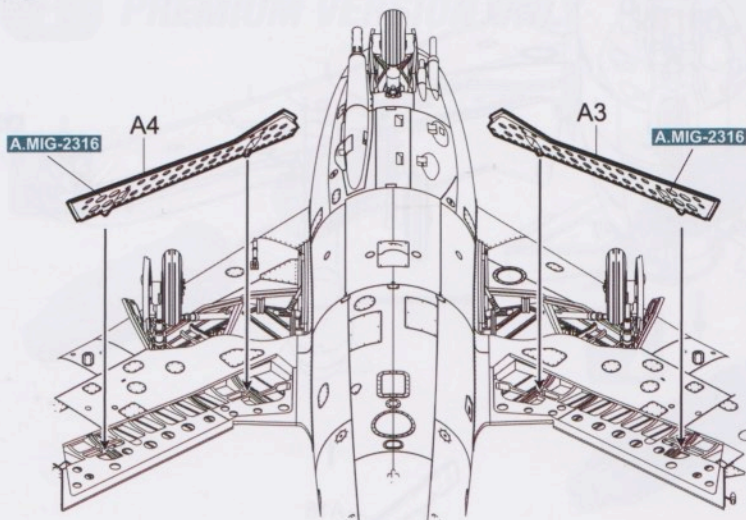

13

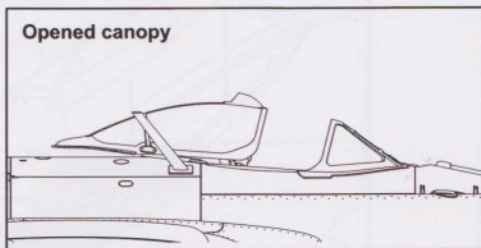

GCM101 - Mig-17F Fresco Canopy Mask
INCLUDED ONLY IN PREMIUM VERSION

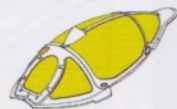

For closed canopy

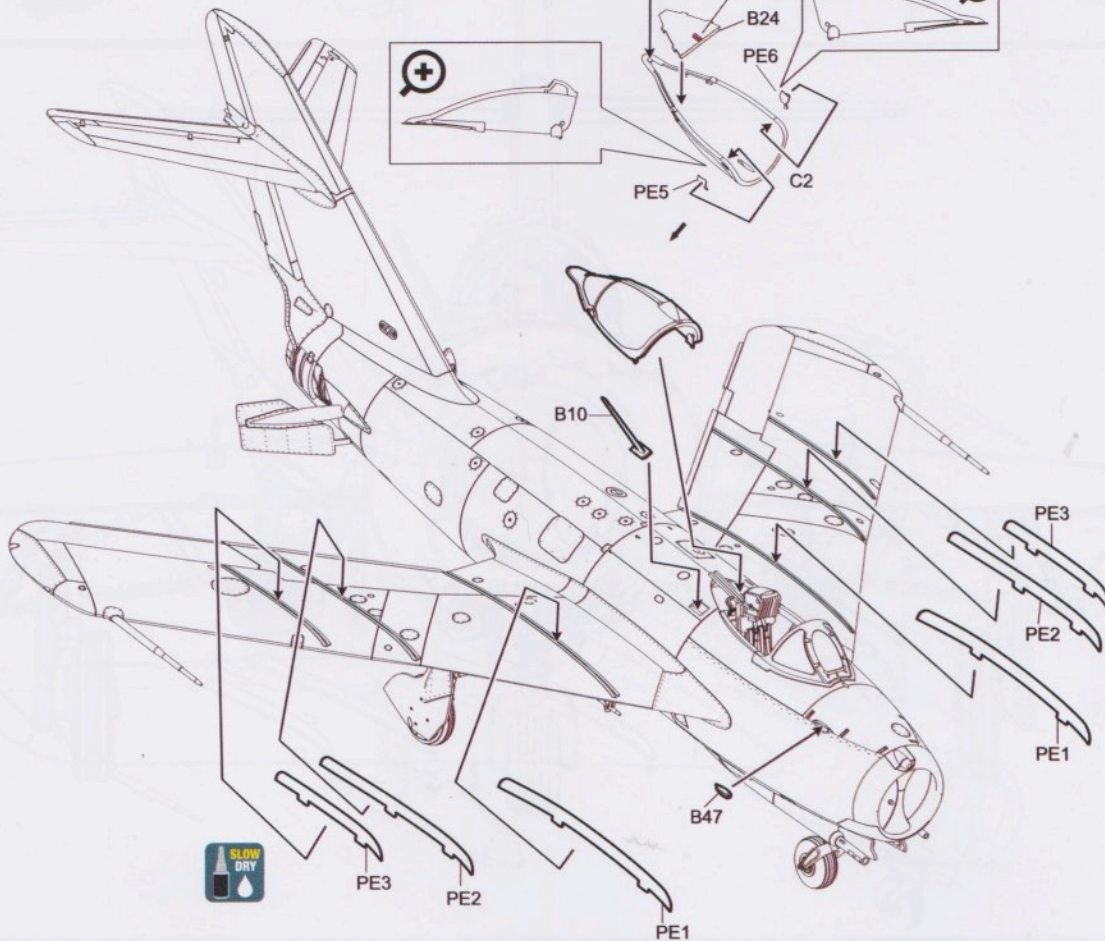
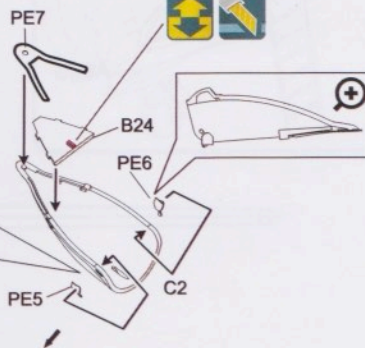
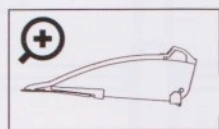

A.MIG-0093

A.MIG-0092

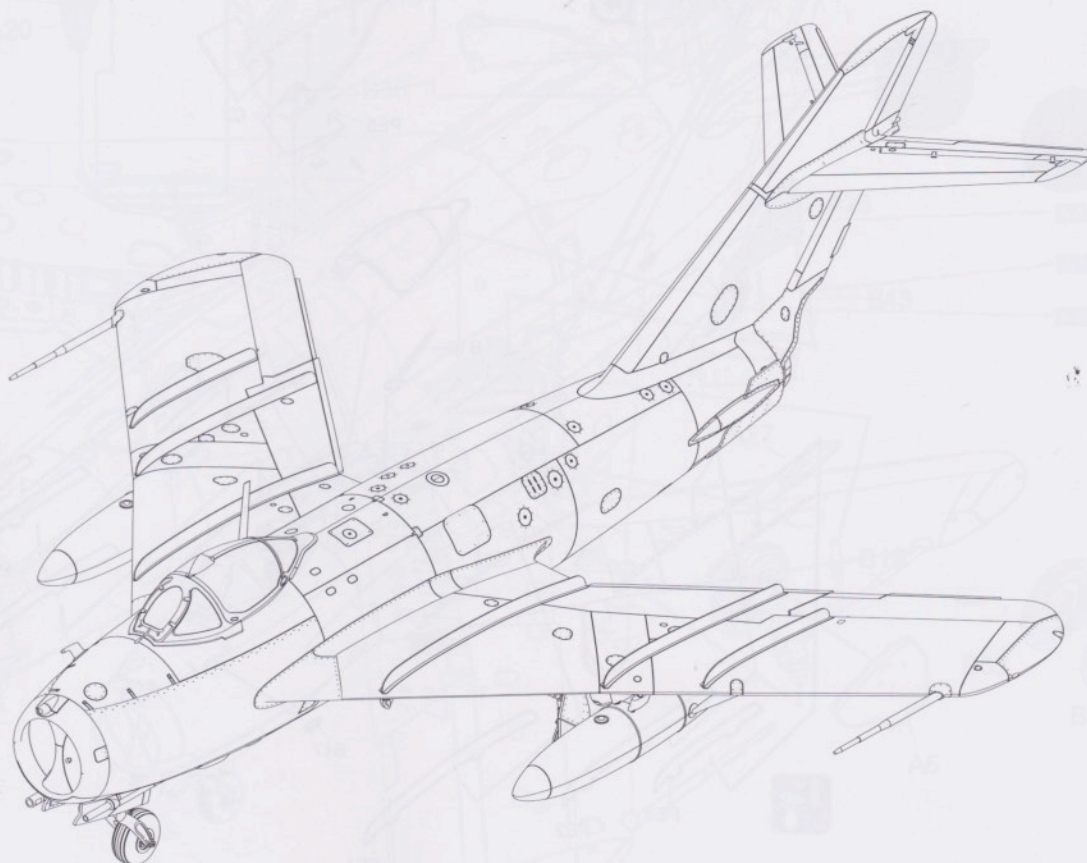
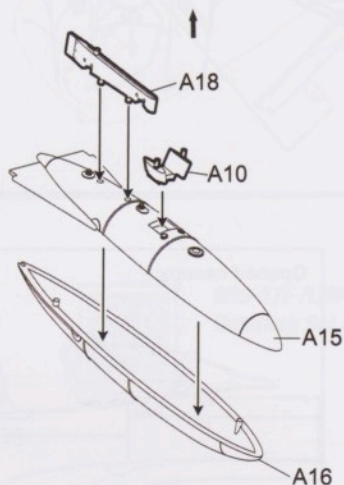
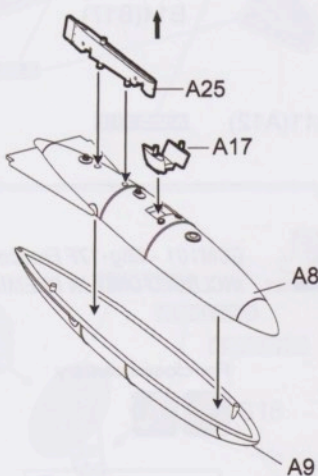
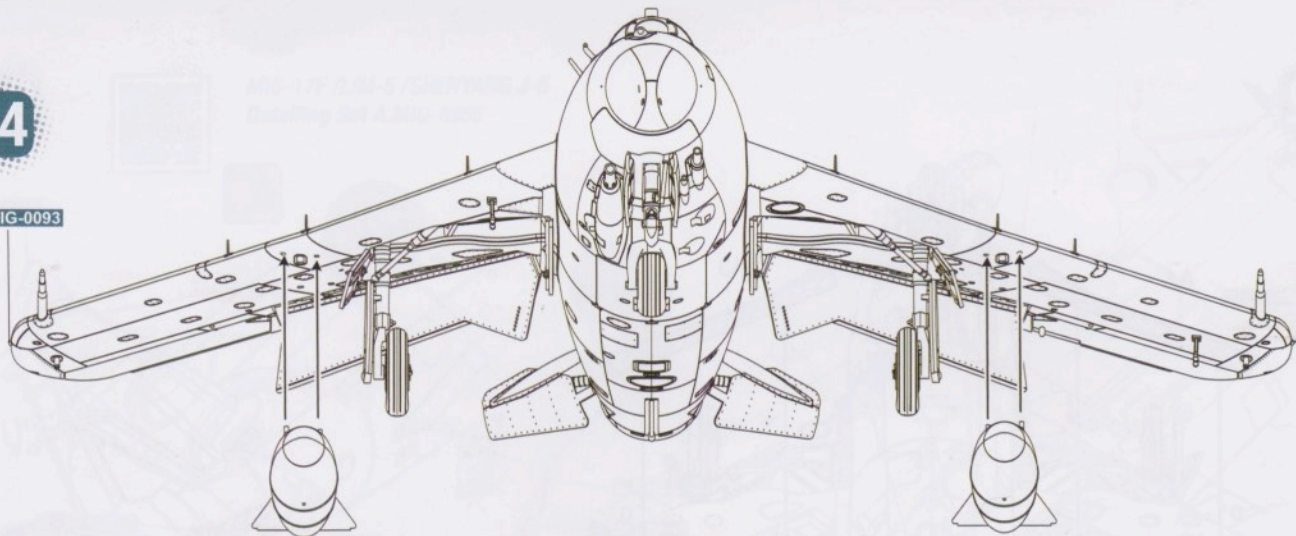



**INCLUDED IN
PREMIUM VERSION ONLY**

MIG-17F / LIM-5 / SHENYANG J-5
Detailing Set A.MIG-8955

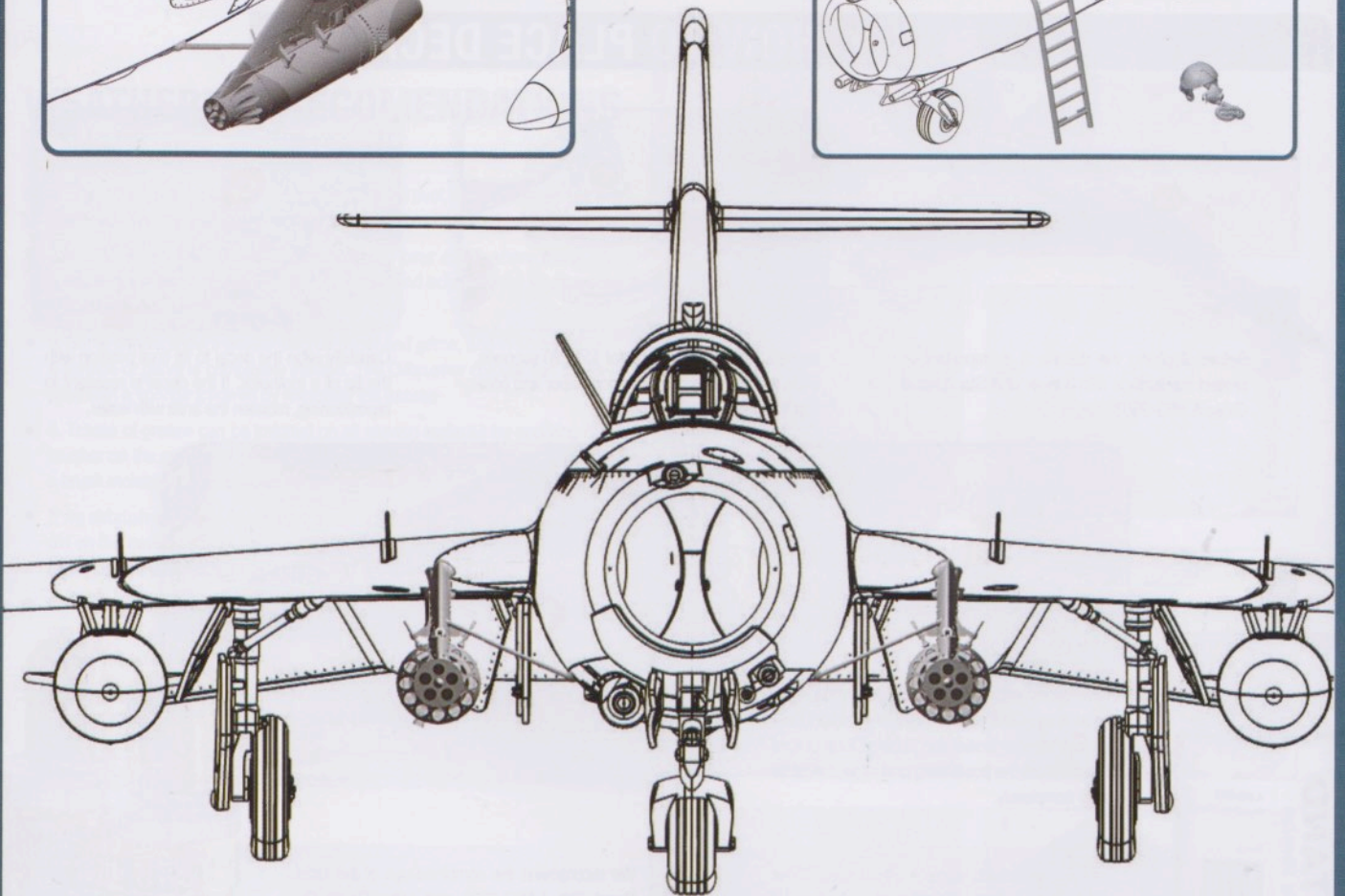
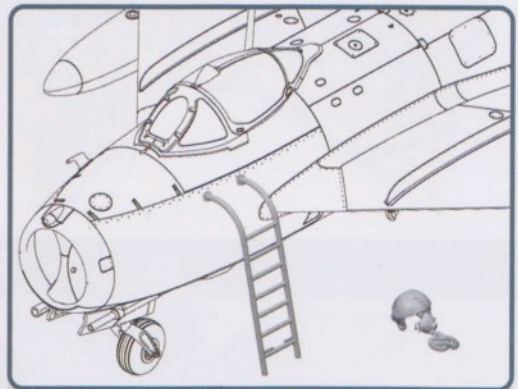
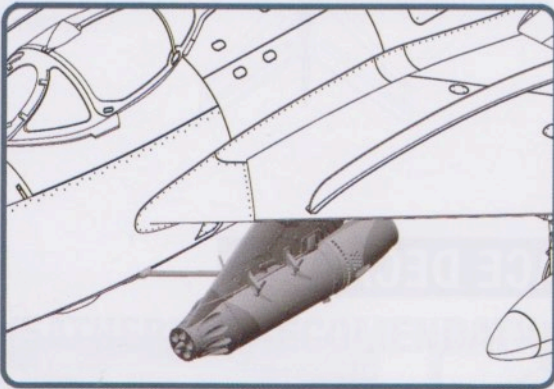
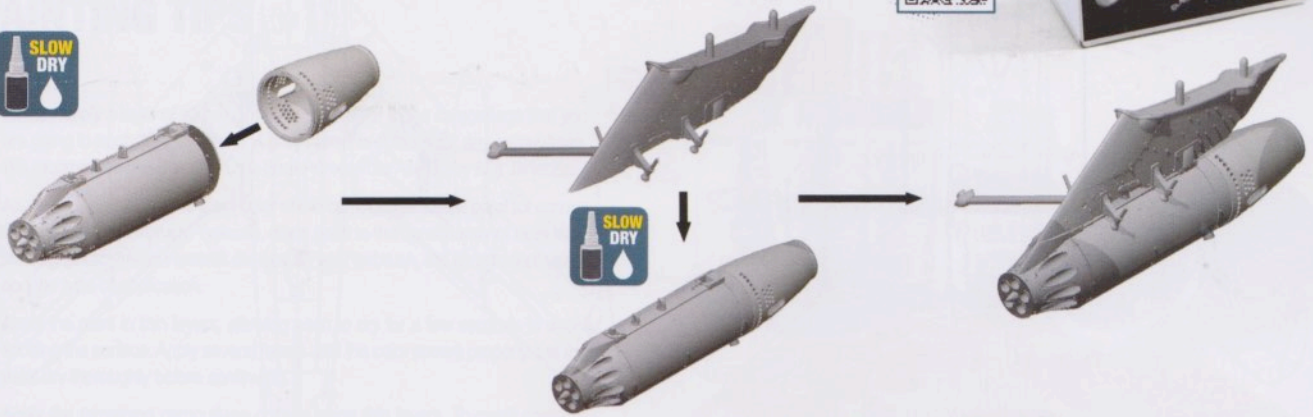

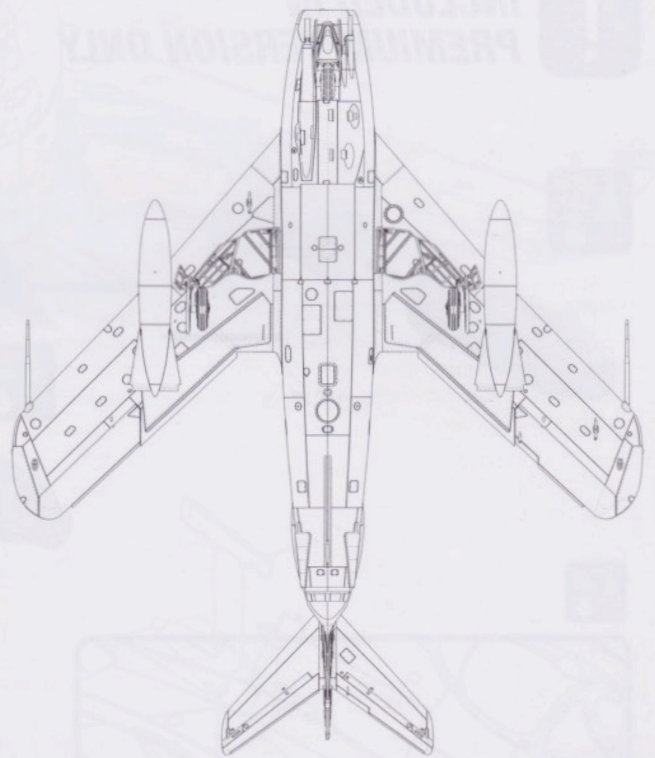
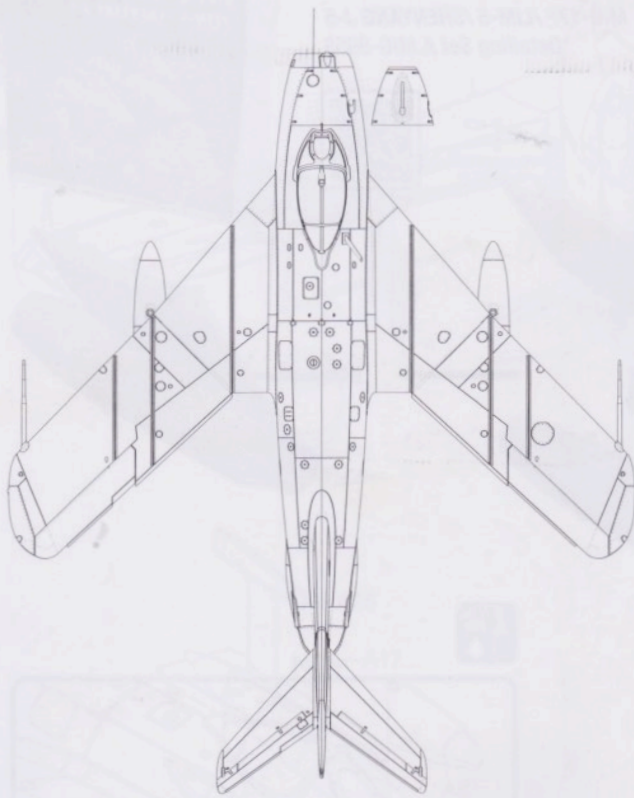

HOW TO PLACE DECALS



Before applying the decals, it is important to protect the surface with a layer of A-Stand Aqua Gloss A.MIG-2503.



Immerse the decal in water for 15 to 20 seconds. Slide the decal from the backing paper and position the decal using a brush.



Carefully align the decal to its final position with the tip of a toothpick. If the decal is resistant to repositioning, moisten the area with water.



Press gently with a cloth or absorbent paper to dry excess water and remove any air bubbles that can appear under the decal. Once placed do not disturb the positioning and allow the decal to dry completely.



For the best results, apply A-Stand Aqua Gloss A.MIG-2503 before and after the process of placing the decals to improve adaptation to the surface and facilitate the following steps.

We recommend the combined use of the Ultra Decal Set A.MIG-2029 and Ultra Decal Fix A.MIG-2030 products for perfect adhesion and surface conformity of your decals.



PAINTING TIPS

- Always apply a layer of primer using a color similar to the camouflage that you are going to apply to your model. A gray primer is suitable for any camouflage. We recommend using acrylic One-Shot Primer from AMMO by Mig Jimenez.
- Apply the base coat of the main color of the camouflage. Dilute paint for correct flow through the airbrush. Typically, dilute paint to the consistency of skim milk, although exact measurements depend on your airbrush, the air pressure used, and the type of application.
- Apply the paint in thin layers, allowing each to dry for a few seconds to avoid flooding the surface. Apply several layers until the color covers properly. Let the paint dry thoroughly before continuing.
- Apply the remaining camouflage colours using thin layers. To mask complex compound features, use Camouflage Masking Putty A.MIG-8012. For masking straight and curved surfaces, AMMO Masking Tape is ideal. To mask periscopes, windows, and other small details we recommend Ultra Liquid Mask A.MIG-2032.



WEATHERING RECOMENDATIONS

1. The PLW enamel product was applied over all rivet and panel lines with a fine brush, usually a tone darker than the base colour is used.
2. Small amounts of Oilbrusher were blended over areas where more dirt tends to accumulate on the real aircraft. Brown and ochre are the tones most commonly used for this.
3. Some panels show a greater degree of dirt and grime, and in some cases, a surface or panel is completely stained. The Oilbrusher colours can be applied with a sponge followed by removing the excess.
4. Traces of grease can be imitated on all moving surfaces by applying Oilbrusher on the seam and dragging it back in the direction of the air flow with a brush moistened with enamel thinner.
5. An airbrush was used to paint the areas with the greatest accumulations of dirt on the lower surfaces using various shades of brown and black, applied highly diluted with Transparator in order to achieve a subtle effect.
6. To simulate traces of hydraulic fluids, the appropriate Oilbrusher colour can be used by applying a drop of oil colour and dragging it towards the trailing edge with a flat brush.
7. The engine parts were emphasized and slightly weathered at the same time by adding a dark wash over the metallic surfaces.
8. To weather airplane wheels in a subtle way, a light pigment tone was applied in small quantities for an accurate effect.

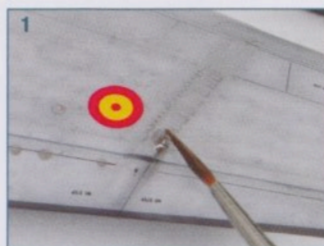

MIG-17F



A.MIG-8508: MiG-17F/LIM-5, U.S.S.R.-G.D.R. 1/48

A.MIG-8512: MiG-17F/LIM-5, U.S.S.R.-G.D.R. 1/48 PREMIUM EDITION
(Includes MiG-17F detailing Set A.MIG-8955)



A.MIG-8509: MiG-17F/LIM-5, Poland-Cuba-Angola 1/48

A.MIG-8513: MiG-17F/LIM-5, Poland-Cuba-Angola 1/48
PREMIUM EDITION (Includes MiG-17F detailing Set A.MIG-8955)



A.MIG-8510: MiG-17F Shenyang J-5, Vietnam-China-North Korea 1/48

A.MIG-8514: MiG-17F Shenyang J-5, Vietnam-China-North Korea 1/48
PREMIUM EDITION (Includes MiG-17F detailing Set A.MIG-8955)



A.MIG-8511: MiG-17F, Egypt-Syria 1/48

A.MIG-8515: MiG-17F, Egypt-Syria 1/48 PREMIUM EDITION
(Includes MiG-17F detailing Set A.MIG-8955)

A.MIG-6054
MIG-17F / LIM-5 / SHENYANG J-5
MODELLER'S VISUAL GUIDE



A.MIG-8955
MIG-17F / LIM-5 / SHENYANG J-5
DETAILING SET



MIG-17F



A.MIG-8510

Painting and Marking Guide

A.MIG-0051 Gray Green

A.MIG-0271 Air Superiority Blue

A.MIG-0195 Silver

A.MIG-0130 Sand Yellow

A.MIG-0068 Dark Green

A.MIG-0231 Light Blue

www.ammo.es

MIG-17F Shenyang J-5 (Chinese built MiG-17F)

Vietnamese Popular Air Force

Viet Nam - 1968. PIMA Air & Space Museum, USA - 2023

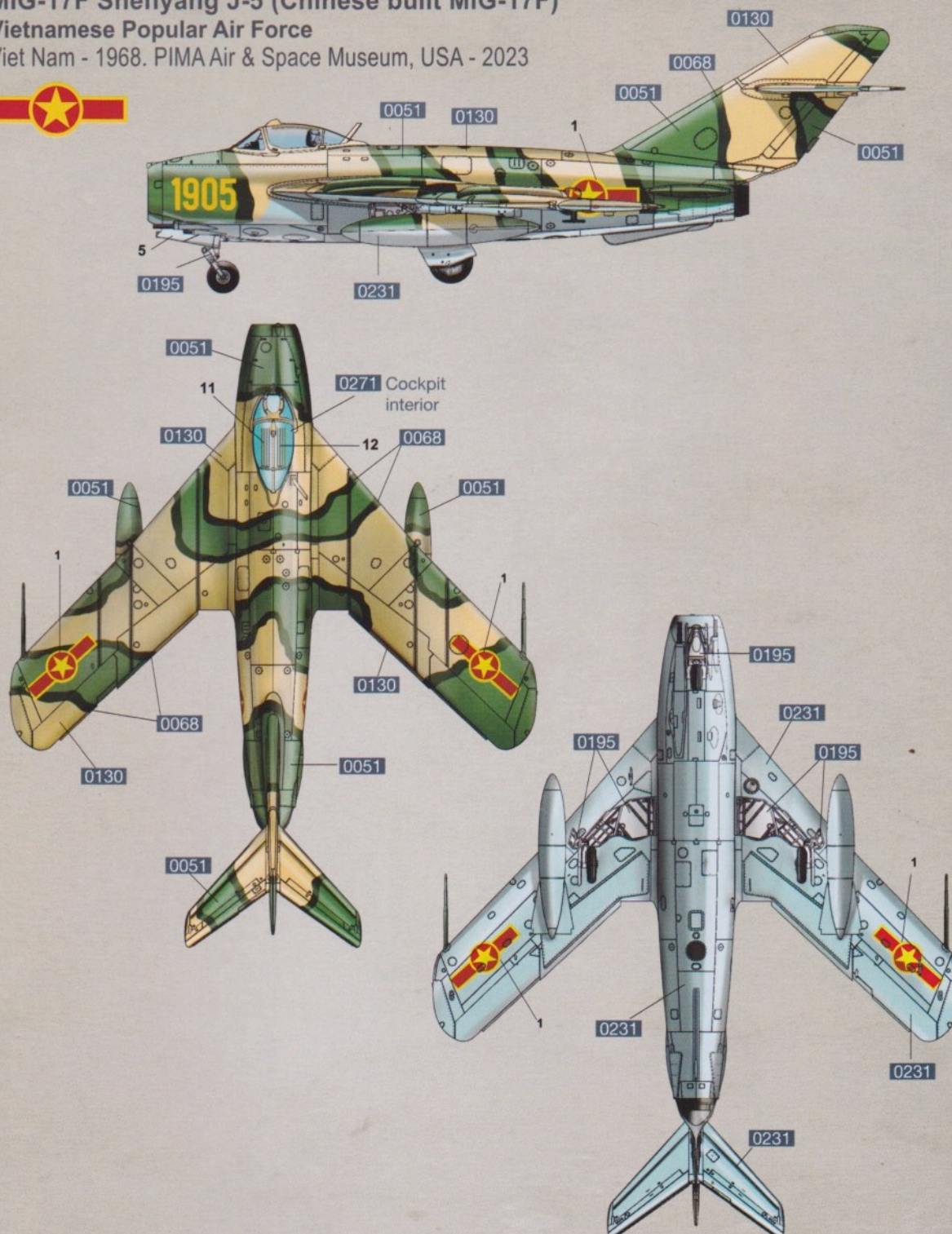

MIG-17F



A.MIG-8510

Painting and Marking Guide

A.MIG-2318

A-Stand Airframe
Aluminium

A.MIG-0271

Air Superiority
Blue

A.MIG-0195

Silver

www.ammo.es

MIG-17F Shenyang J-5 (Chinese built MiG-17F)
Popular Liberation Army Air Force
China - 1962

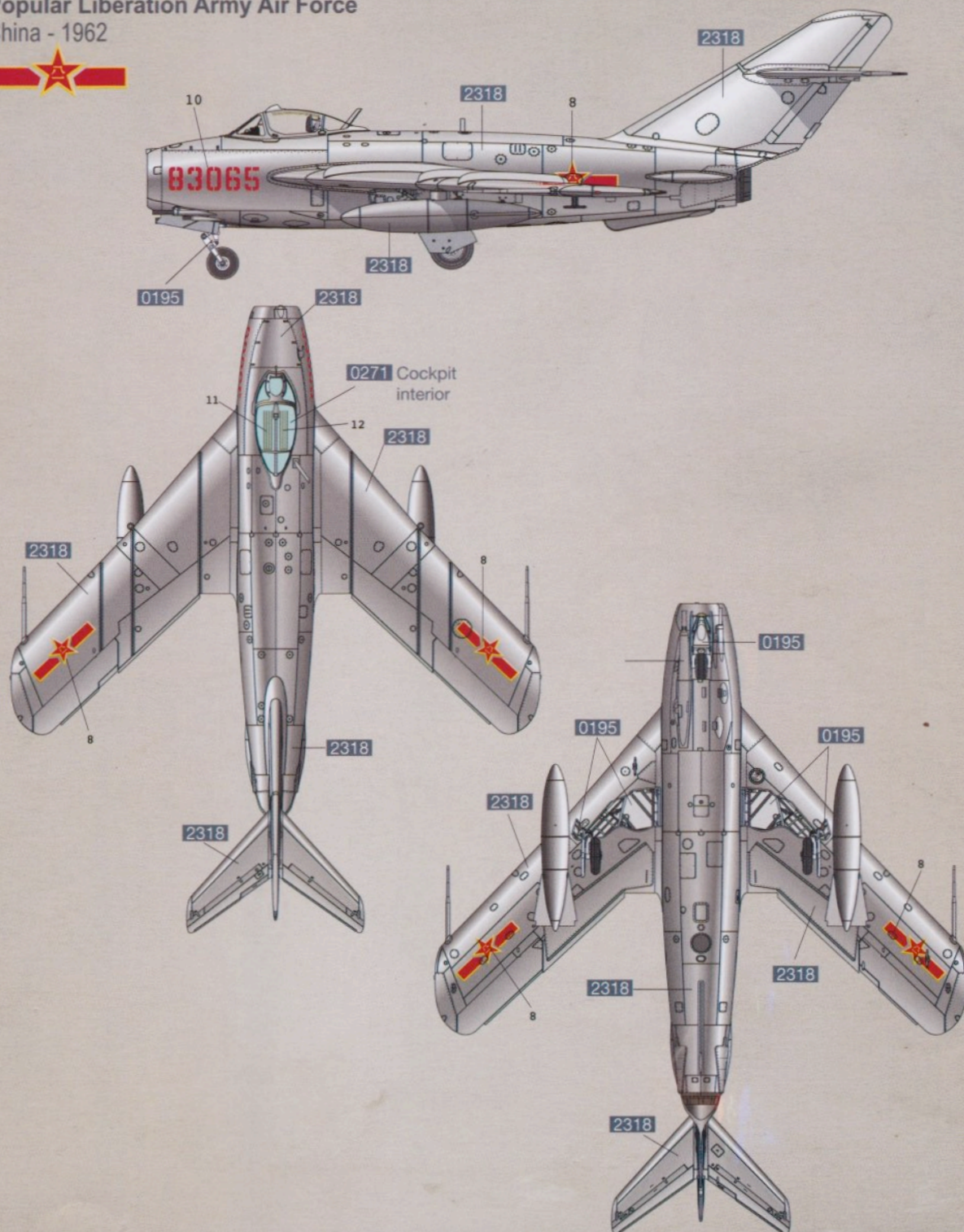

MIG-17F



A.MIG-8510

Painting and Marking Guide

- A.MIG-0249 Light Blue
- A.MIG-0271 Air Superiority Blue
- A.MIG-0195 Silver
- A.MIG-0209 Light Grey
- A.MIG-0086 Dark Blue

www.ammo.es

MIG-17F Shenyang J-5 (Chinese built MiG-17F)
Popular Liberation Army Air Force
China

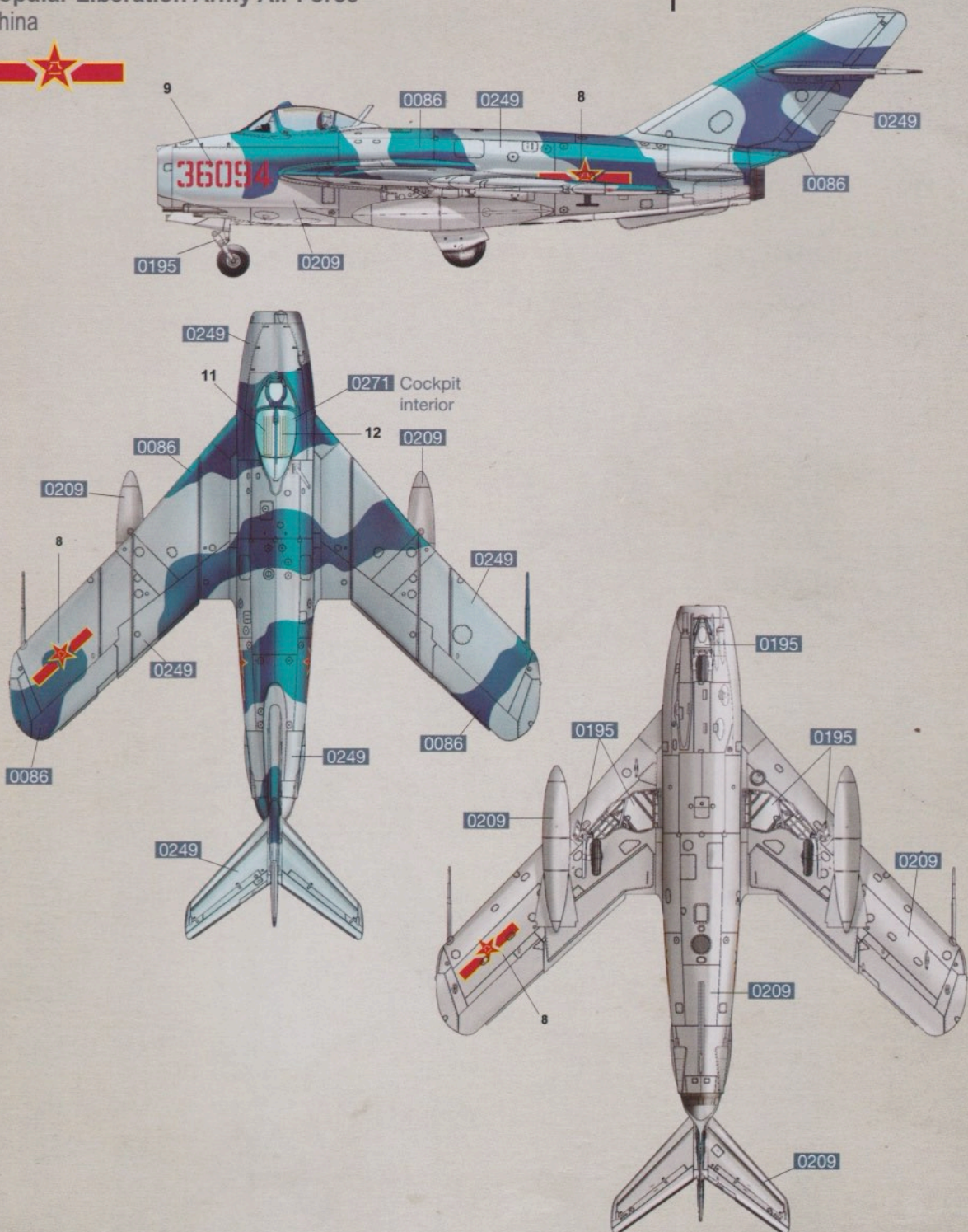

MIG-17F



A.MIG-8510

Painting and Marking Guide

A.MIG-2318

A-Stand Airframe
Aluminium

A.MIG-0271

Air Superiority
Blue

A.MIG-0195

Silver

A.MIG-0209

Light Gray

www.ammo.es



MIG-17F Shenyang J-5 (Chinese built MiG-17F)

Korean People's Army Air Force

North Korea - 2018

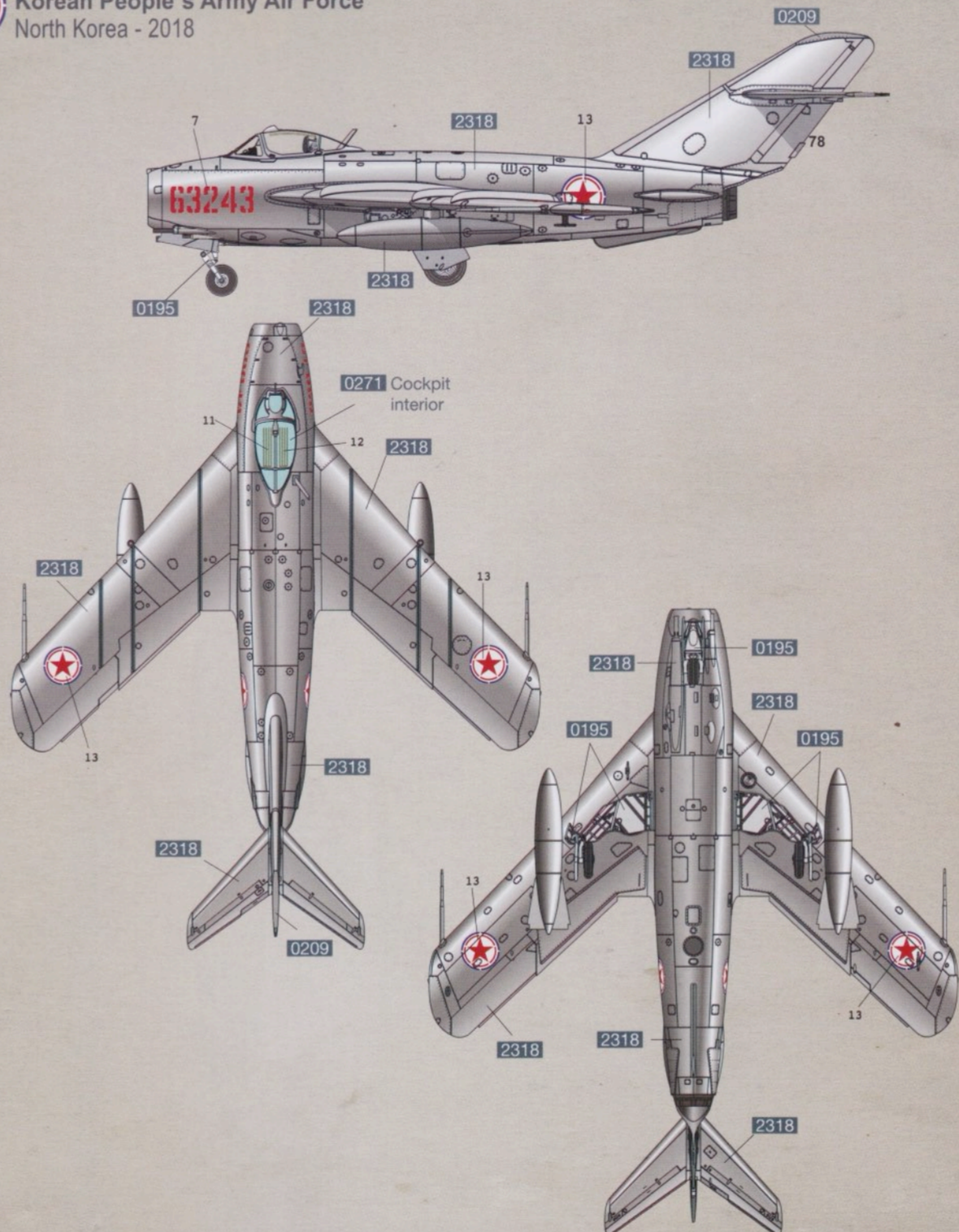

MIG-17F



A.MIG-8510

Painting and Marking Guide

- A.MIG-0080 Medium Green
- A.MIG-0206 Dark Green
- A.MIG-0271 Air Superiority Blue
- A.MIG-2318 A-Stand Airframe Aluminium
- A.MIG-0195 Silver

www.ammo.es

MIG-17F Shenyang J-5 (Chinese built MiG-17F)
Flown by aces Le Hai and "Colonel Tomb" Nguyễn Tuân.
932nd Fighter Regiment, VPAF. Tho Xuan - Viet Nam - 1969

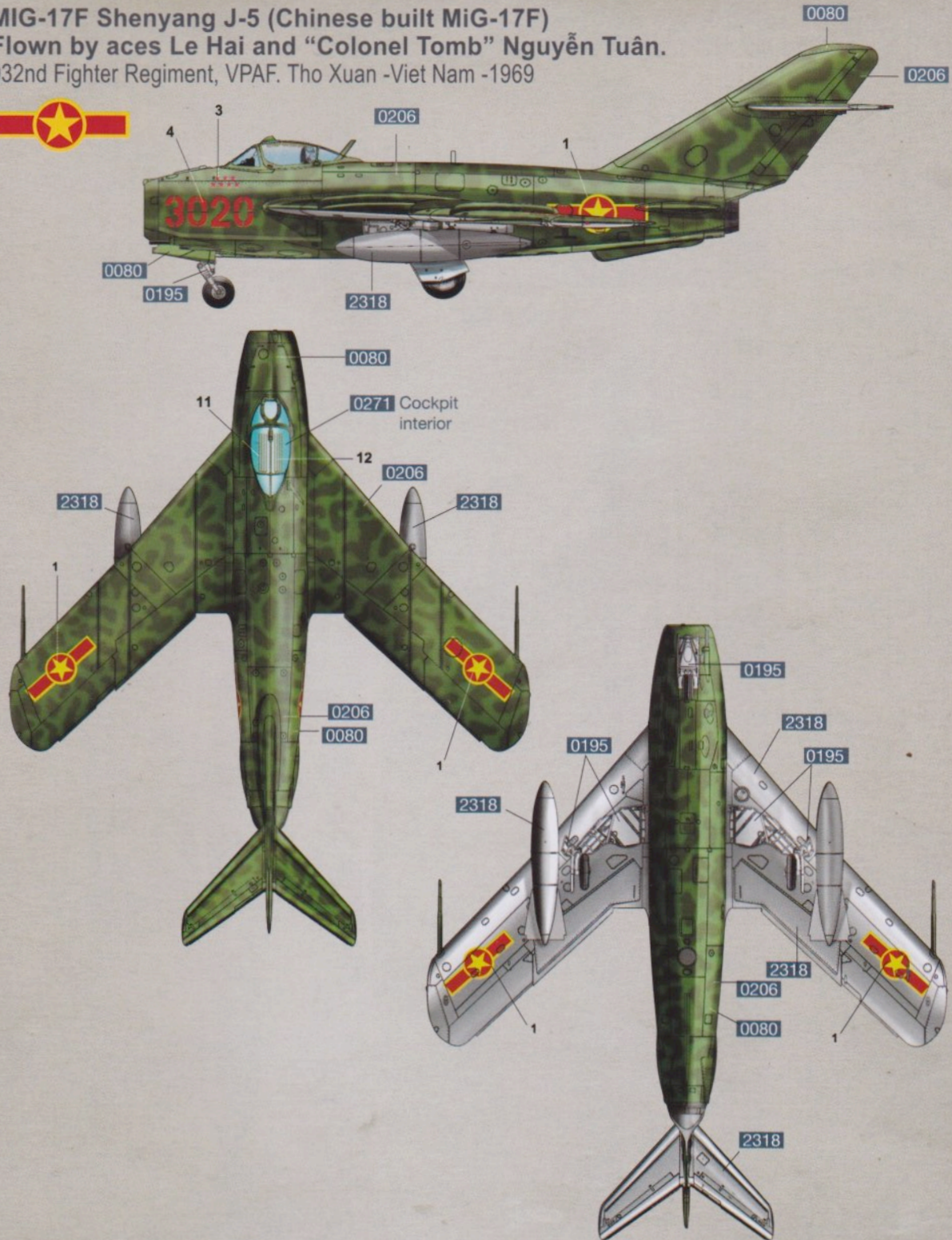

MIG-17F



A.MIG-8510

Painting and Marking Guide

- A.MIG-0206 Dark Green
- A.MIG-0271 Air Superiority Blue
- A.MIG-2318 A-Stand Airframe Aluminium
- A.MIG-0195 Silver

www.ammo.es

Shenyang J-5 (Chinese built MiG-17F)
 Flown by ace Ngo Duc Mai.
 923rd Fighter Regiment, VPAF. Hanoi - Viet Nam - 1967

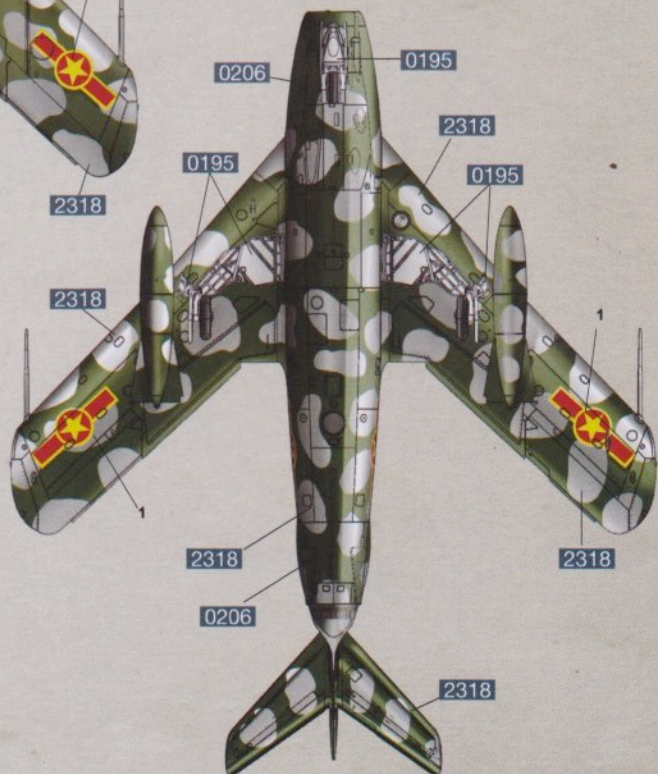
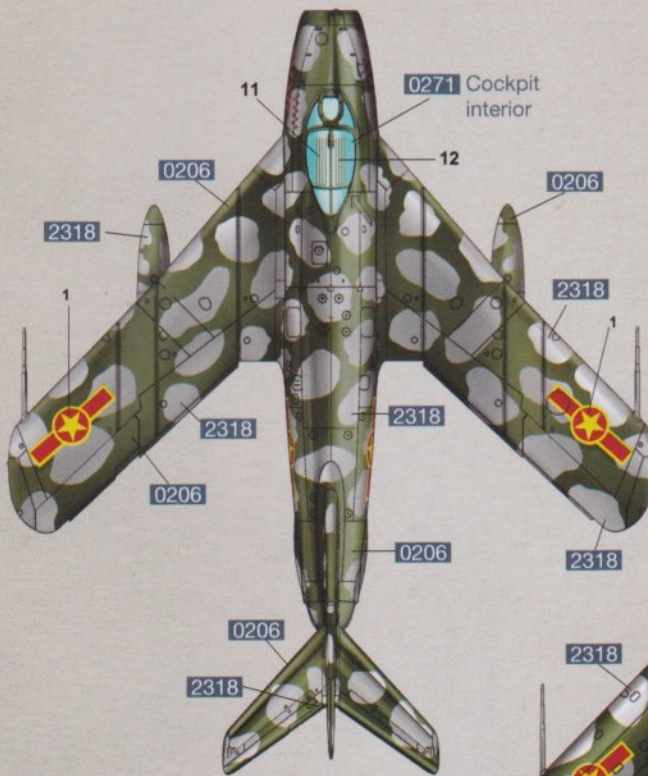
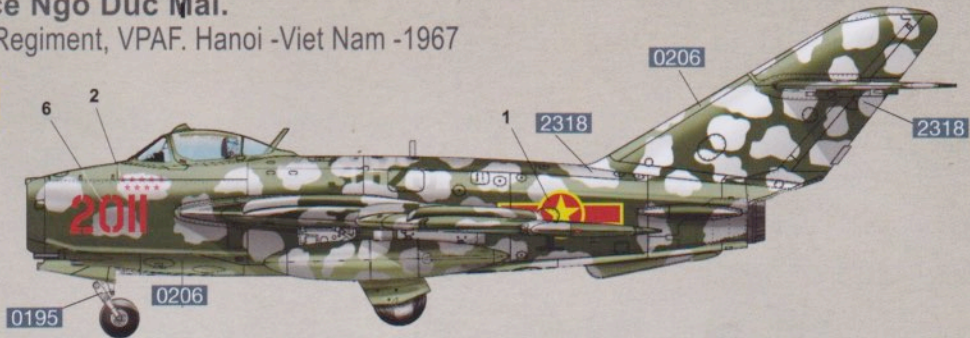

QUICK SET 3D ACRYLIC INSTRUMENT PANELS

MiG-17F FRESCO

SCALE 1/48 RFSQS-48186 Recommended kit AMMO

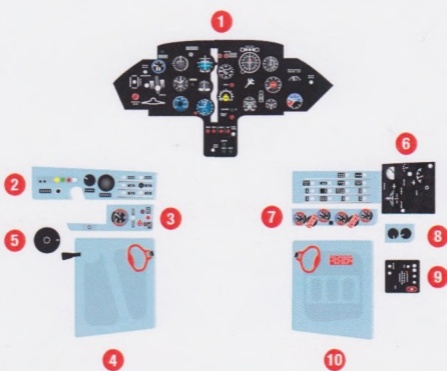

ASSEMBLY INSTRUCTION

ORIGINAL KIT PARTS: B7, B20, B38

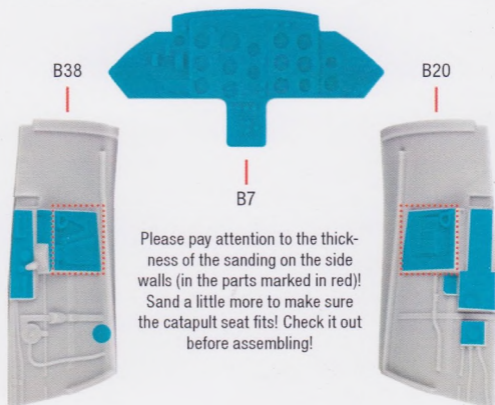

ATTENTION! The blue parts are not smooth! Please sand them first!

Attention! The Quick Set 3D acrylic parts must not be cut with scalpel, they break easily! Handle with care!

The parts can be glued together with PVA glue or Cyanoacrylate. The upgrade parts can also be washed with enamel or acrylic paint. Usable varnish types: ester, white spirit, nitro, lacquer and acrylic-based. Durable UV resistant surface. Maximal bendability, tolerance 5 degrees.

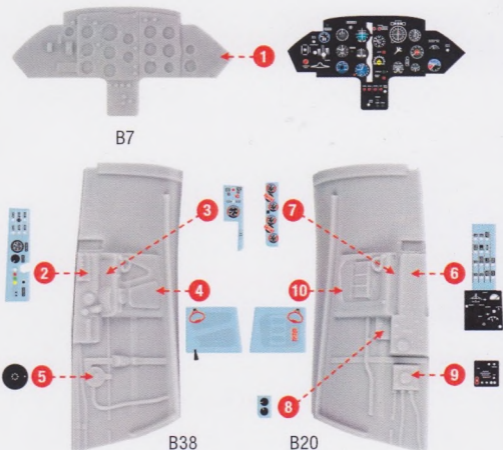

Recommended interior color A.MIG-271