

ACADEMY

HOBBY MODEL KITS

TA980



미육군 자주포 전차 M-18 헬캣

1/35 SCALE

M-18 HELLCAT

U.S. ARMY GUN MOTOR CARRIAGE

【 TECHNICAL SPECIFICATION 】

CREW : 5 men

DIMENSIONS

- *Length overall : 262 in.
- *Hull length : 214 in.
- *Width : 113 in.
- *Height : 101½ in.
- *Clearance : 14¼ in.

WEIGHT

- *Loaded : 37,557 pdrs.
- *Empty : 35,526 pdrs.

GROUND PRESSURE : 11.9p.s.i.

ARMOR

- *Turret Front : 1 in.
- *Turret Sides & Rear : ½ in.
- *Hull front, Sides, Rear : ½ in.
- *Hull Top : ½ in.
- *Hull Floor : ¼ in.

ARMAMENT

- *1×76mm M1/M1A1 Gun/
- *1×12.7mm Cal.50 MG

AMMUNITION : 45 / 840 rounds

PERFORMANCE

- *Max speed : 55 miles/h
- *Trench crossing : 74 in.
- *Fording depth : 48 in.
- *Max gradient : 60 %
- *Range : 105 miles
- *Turning radius : 33 ft.

TRACK : T-69 Steel 14.38 in.,
Pitch 5.11 in.

SUSPENSION

- *Torsion bar
- *Road wheels 26 in.×4½ in.

ENGINE

Continental R-975 C1 340hp
/C4 400hp 9cylinder aircooled

TRANSMISSION : Torqmatic 3FIR

FUEL : 170 U.S.gallons

PRODUCTION

A Total of 2,507 vehicles in July
1943 until March 1945.

【 성능 및 제원 】

승무원 : 5명

길 이

- *전장 : 665.48 cm
- *차체장 : 543.56 cm
- *전폭 : 287.02 cm
- *전고 : 257.65 cm
- *지상고 : 36.2 cm

중 량

- *전투 중량 : 17톤
- *차체 중량 : 16.1톤

접지압 : 0.83 kg/cm²

장 갑

- *포탑 전면 : 2.54 cm
- *포탑 측,후면 : 1.27 cm
- *차체 전,측,후면 : 1.27 cm
- *차체 상면 : 0.8 cm
- *차체 하면 : 0.64 cm

무 장

- *7.5 cm M1/M1A1 주포 1문/
- *1.27 cm Cal.50 기관총 1정

탄 약 : 포탄45 / 기총탄840발

기동성

- *최대 속도 : 88 km/h
- *초호(超壕) 반경 : 188 cm
- *도하 수심 : 122 cm
- *행동 거리 : 168 km
- *선회 반경 : 1000 cm

캐터필러 : T-69 철제 36.5 cm,
피치 12.9 cm

서스펜션

- *토션 바 식
- *전륜 66.04 cm×11.43 cm

엔 진

콘티넨탈 R-975 C1 340마력
/C4 400마력 9기통 공냉식

트랜스미션 : 토오코맥틱 3FIR

연료적재량 : 643.45 리터

생 산

1943년 7월부터 1945년 3월
까지 총 2,507대 생산.

#1375

■ 조립하기전에

- 제품을 조립하기전에 설명서를 끝까지 잘 읽어본다.
- 부품을 자를때에는 칼이나 니퍼로 깨끗이 잘라준다.
- 접착하기전에 부품을 맞추어 확인한 후 접착한다.
- 접착제를 사용할 곳과 사용하지않는 곳에 주의하고 너무 많이 바르지 않도록 한다.
- 에나멜 페인트나 접착제를 사용할때에는 창문을 열어 환기를 시키고 화기를 멀리한다.

■ 직매점 겸A/S센터

■ A/S센터

■ 총판점 겸A/S센터

삼선교:742-9293, 대치동:552-9293, 용산:706-9293, 양재동:575-9997

본사:908-7000(교환147), 동대문:745-9293

안양아카데미:(0343)58-5591, 양천아카데미:691-7108,

강남아카데미:522-1577, 노원아카데미:907-0940,

대구아카데미:(053)744-9293, 부산아카데미:(051)293-7449

♣고객상담문의:080-969-7000

1

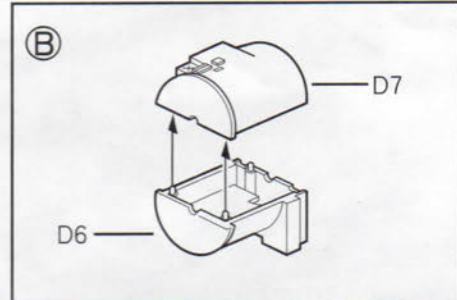
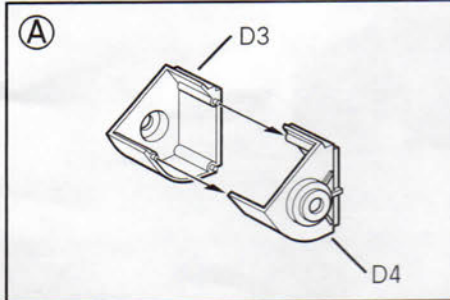

● → 접착한다. CEMENT ● - - - - - → 접착금지. DO NOT CEMENT
※ ()는 반대쪽 부품 번호임. () is opposite number.

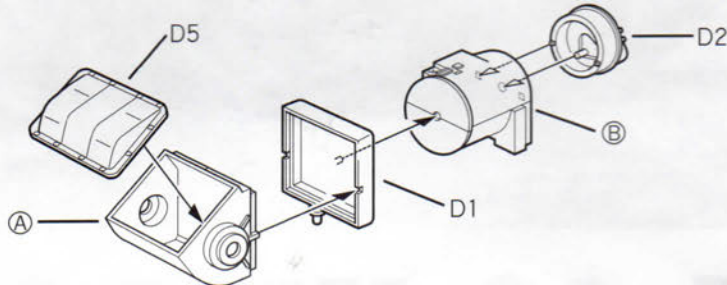

▶무광백색 Flat White

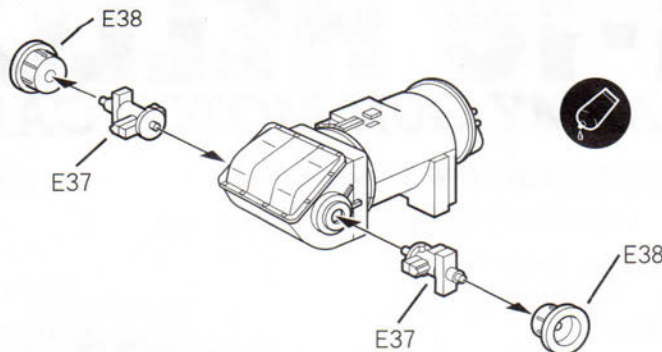

2

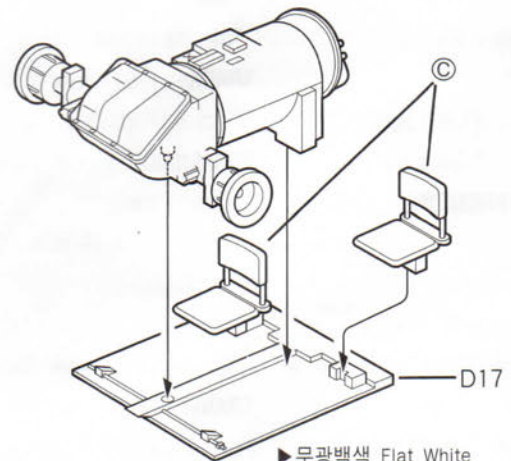
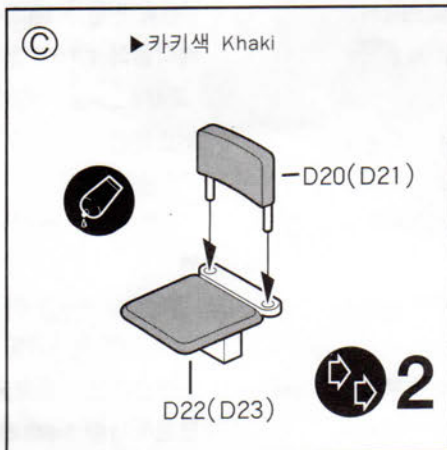

▶무광백색 Flat White

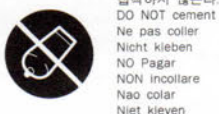

3

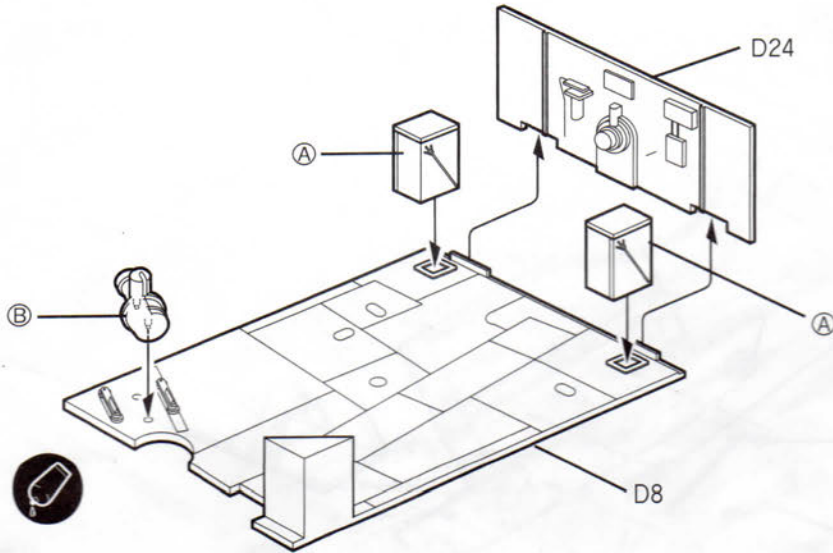
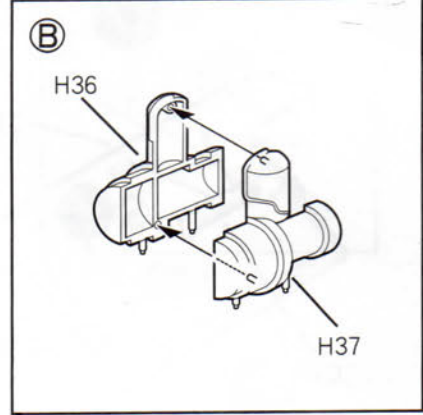
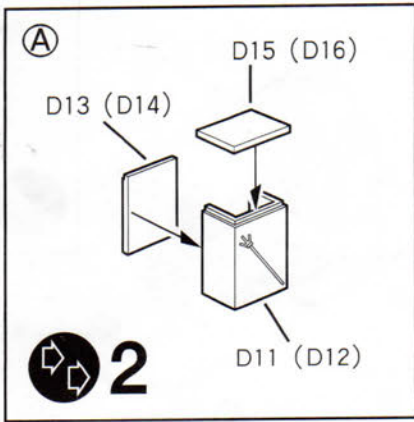

4

▶ 차체 내부색 Hull Interior
 전체 무광백색 Overall Flat White

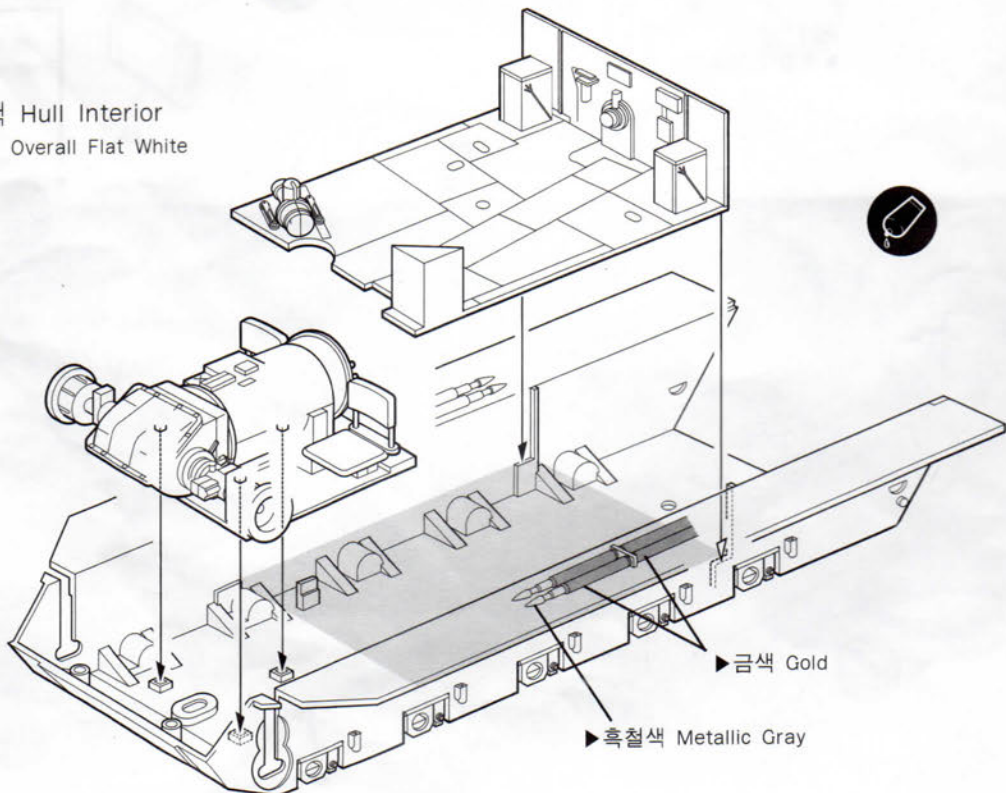

5

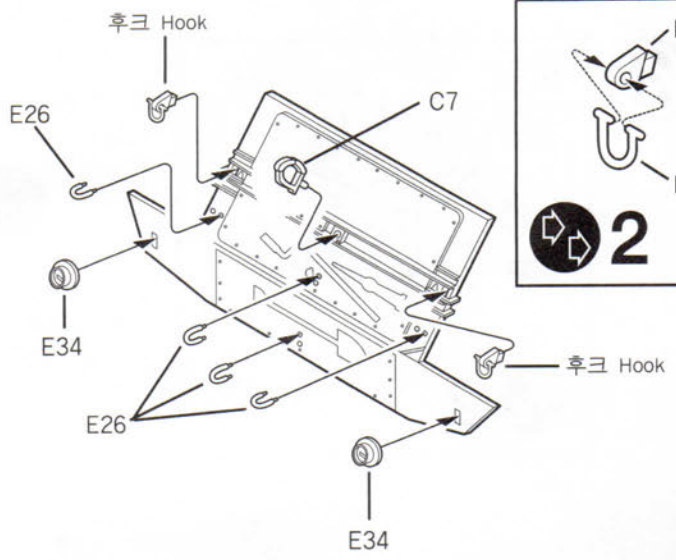
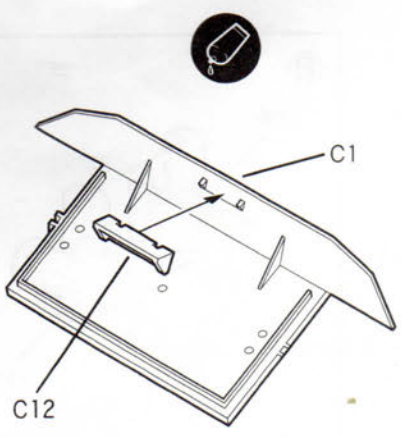

후크 HOOK

2

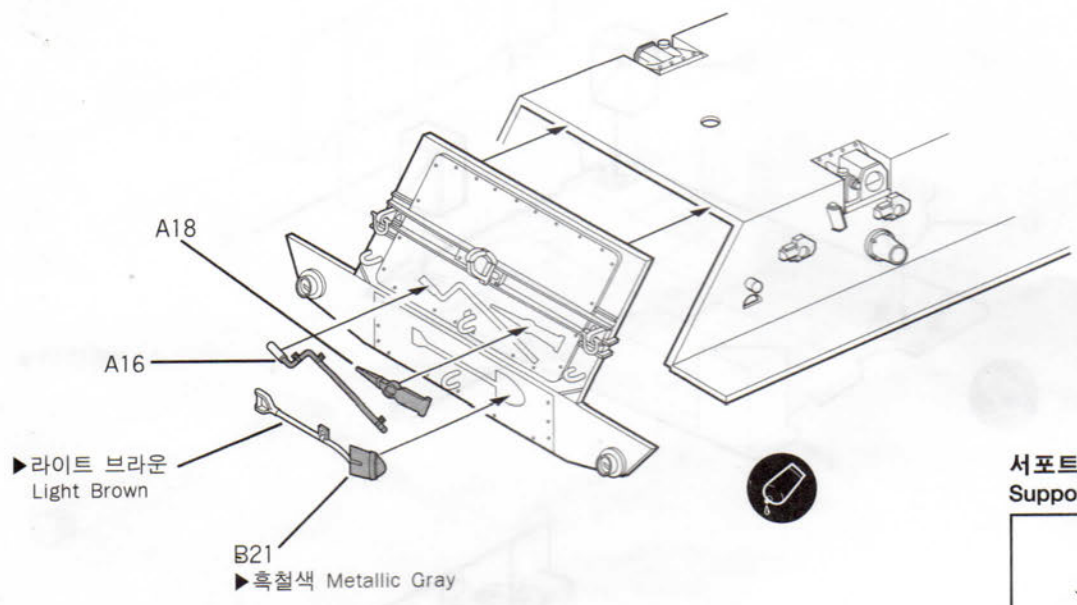

서포트 롤러 Support Roller

8

6

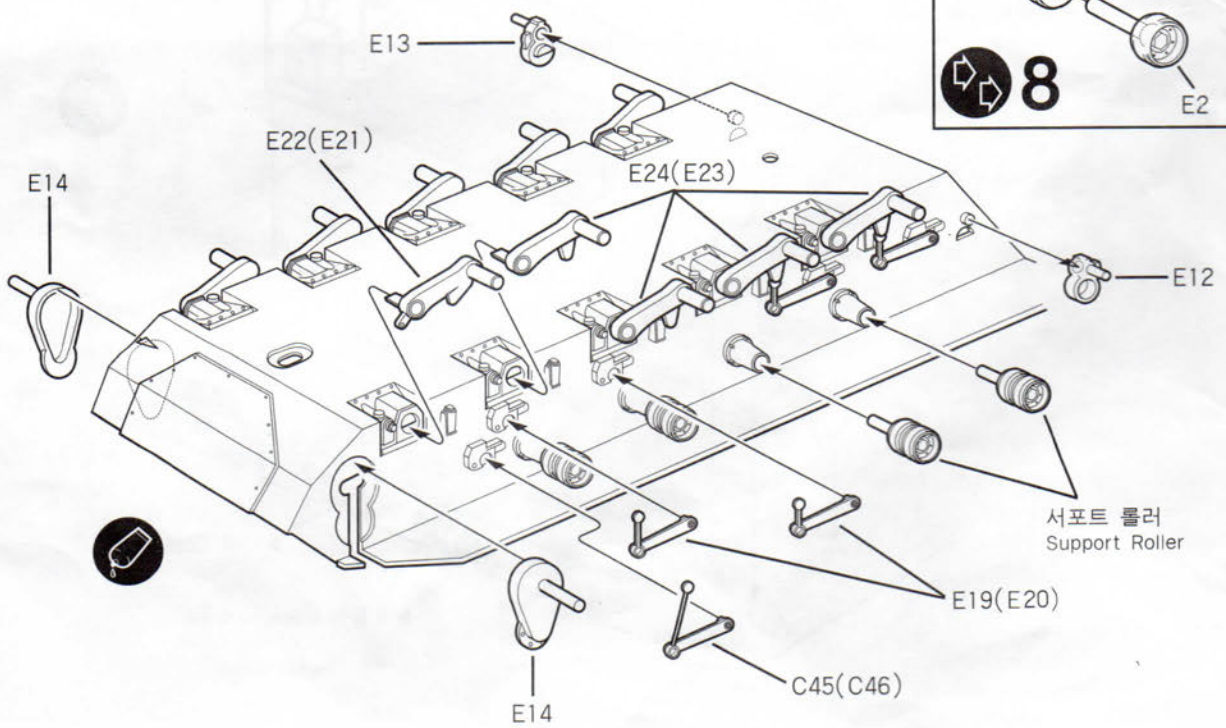

7

① 전문 Road Wheel

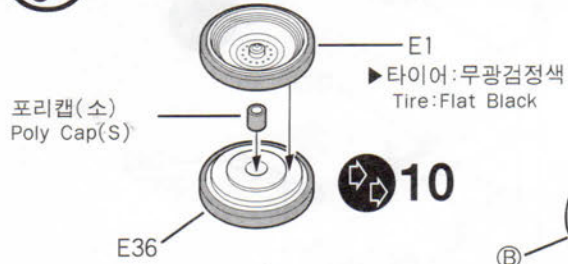

② 아이들러휠
Idler Wheel

2

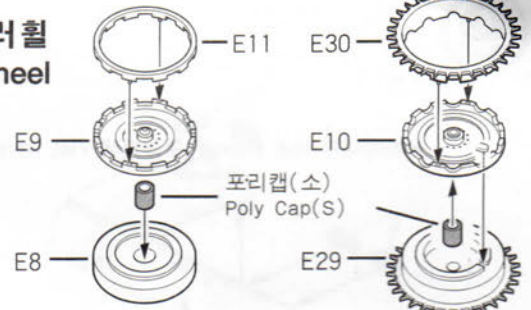

③ 기동륜
Drive Sprocket

2

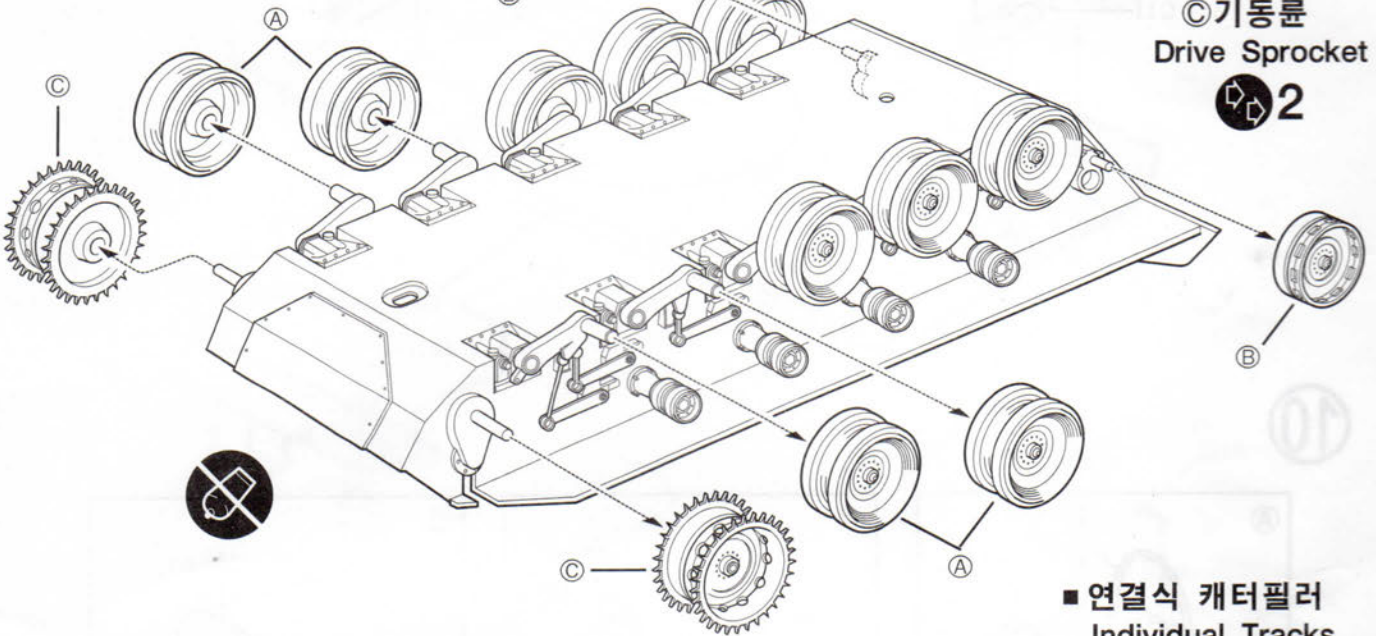

■ 연결식 캐터필러
Individual Tracks

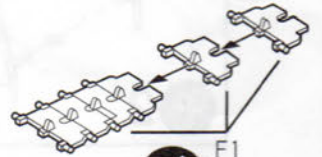

8

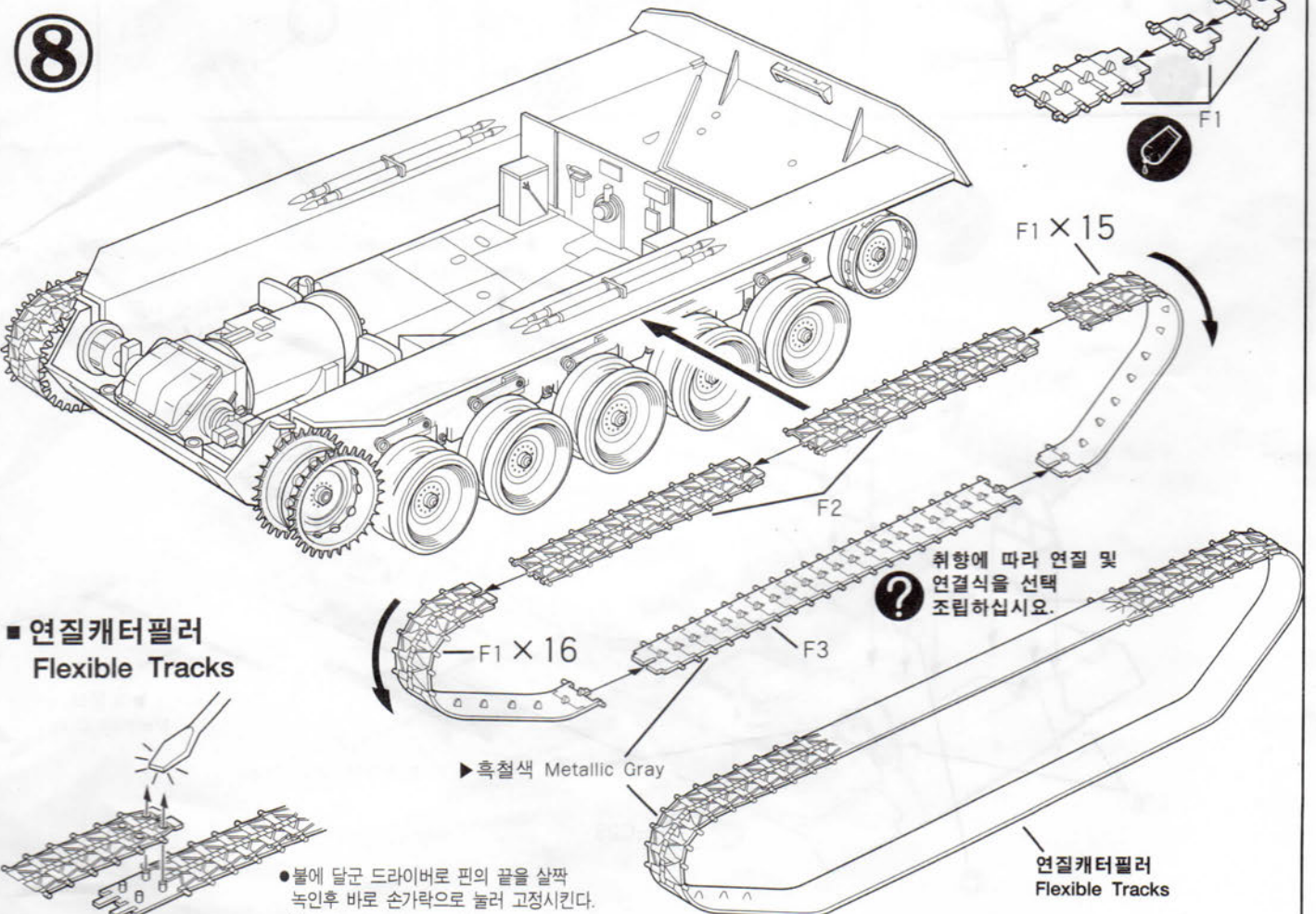

■ 연결캐터필러
Flexible Tracks

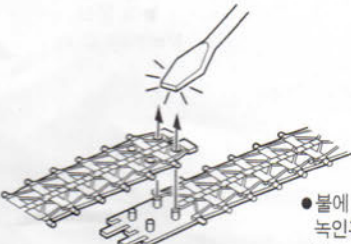

9

▶차체내부 Hull Interior: 무광백색 Flat White

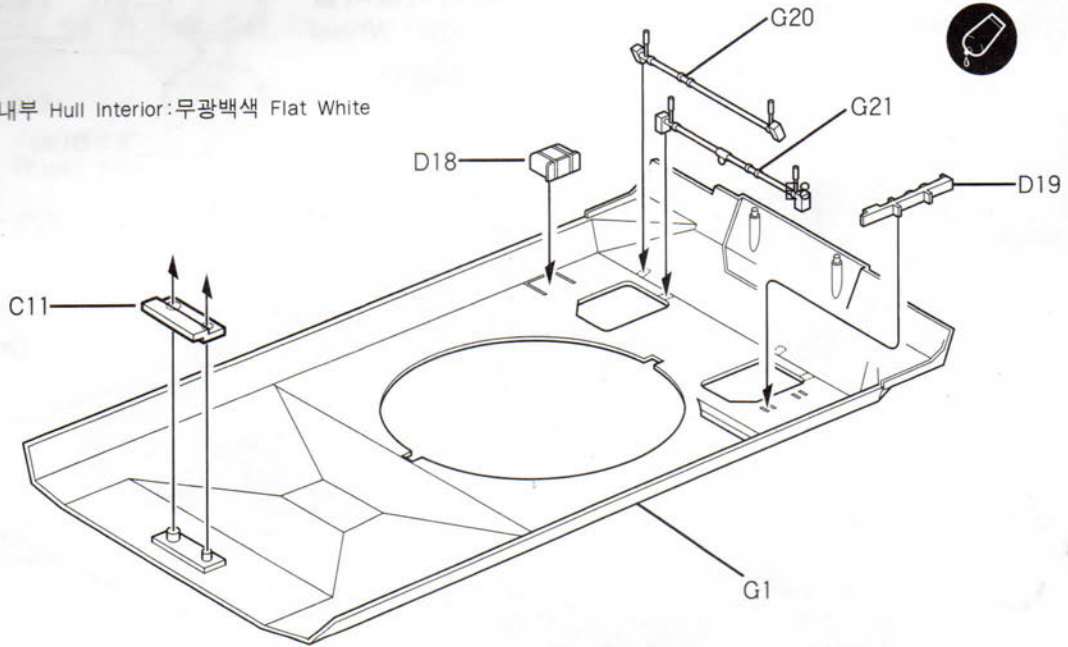

10

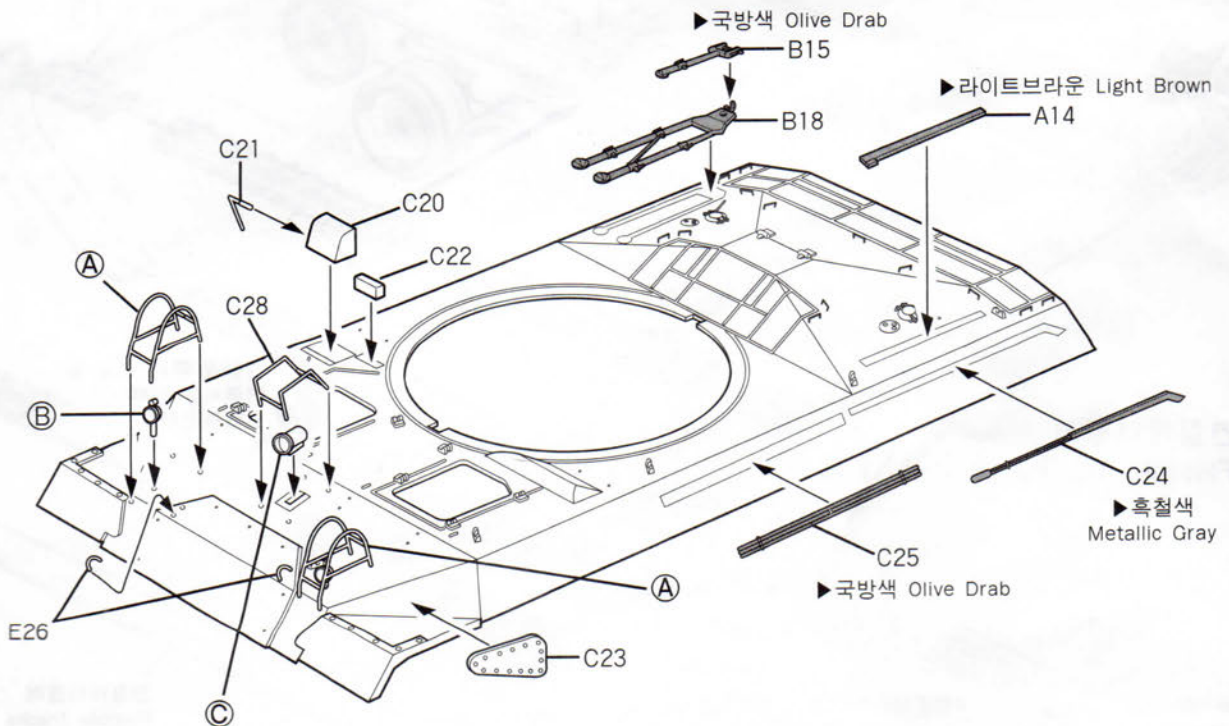
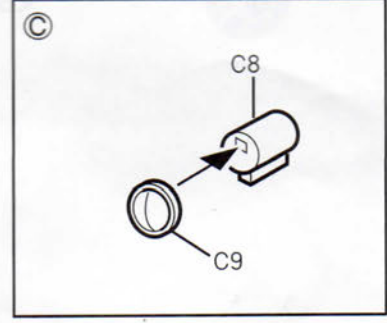
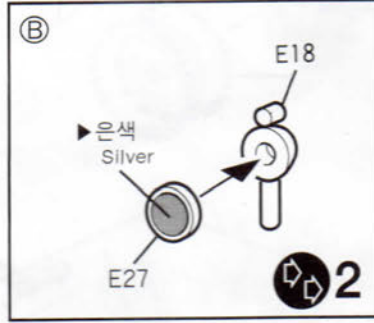
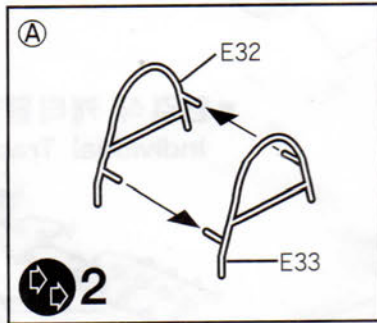

11



개폐 선택한다.
Choice to open
or closed position.

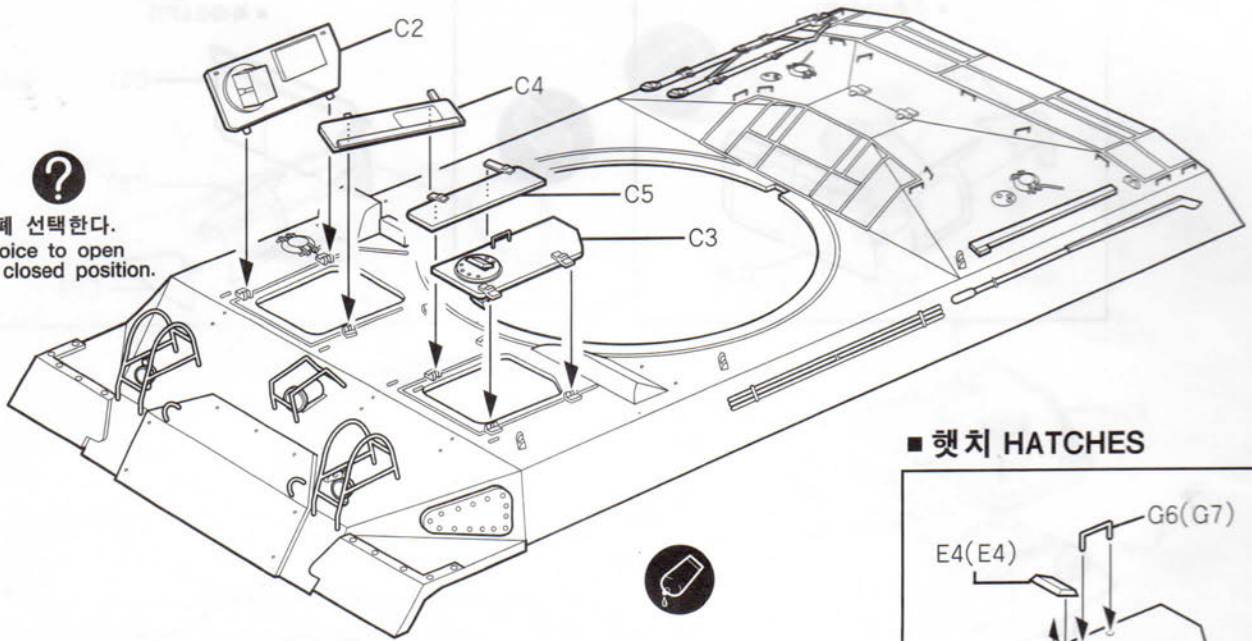

■ 햇치 HATCHES

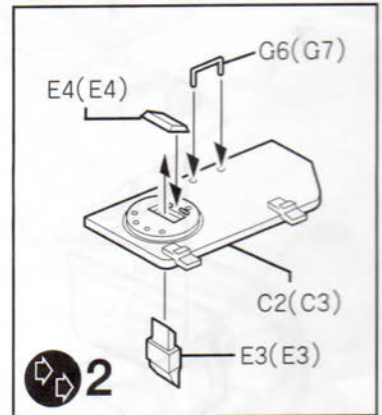

12

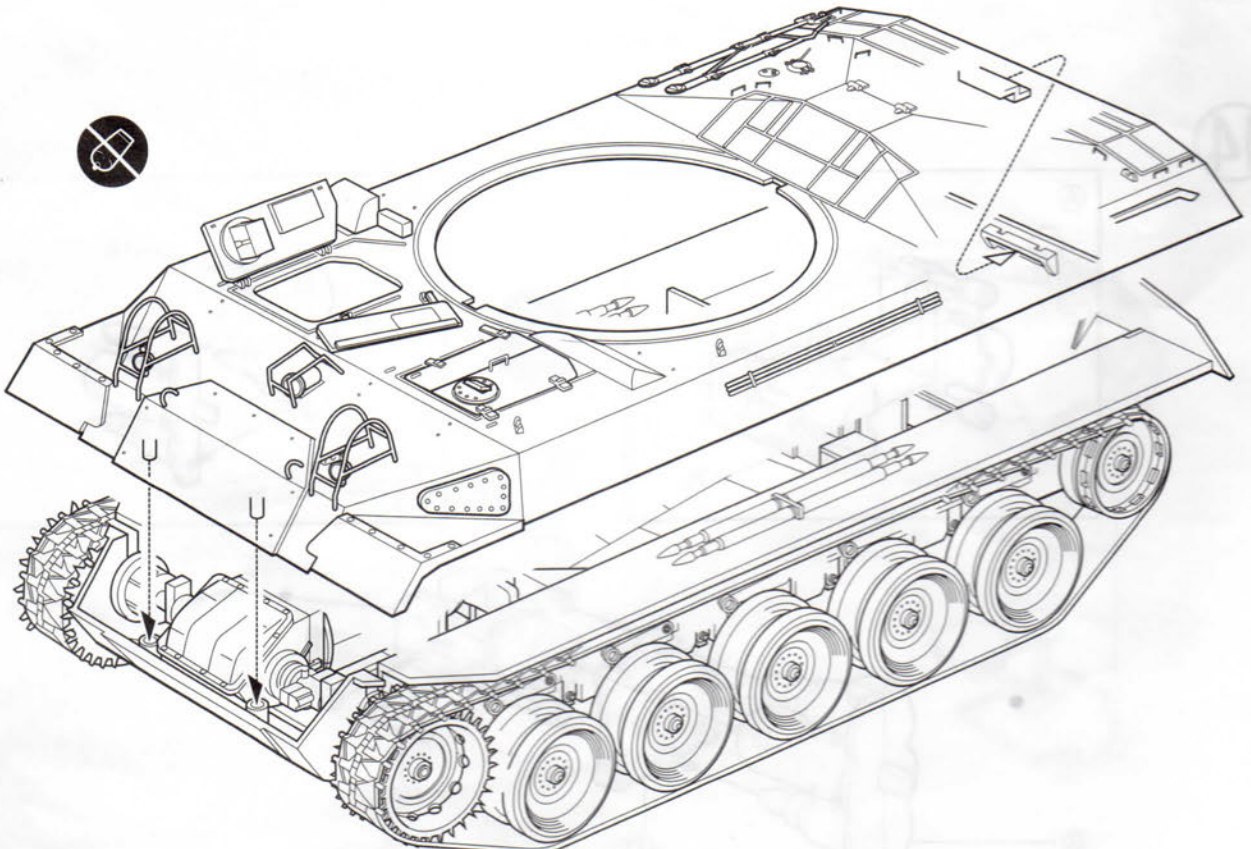

13

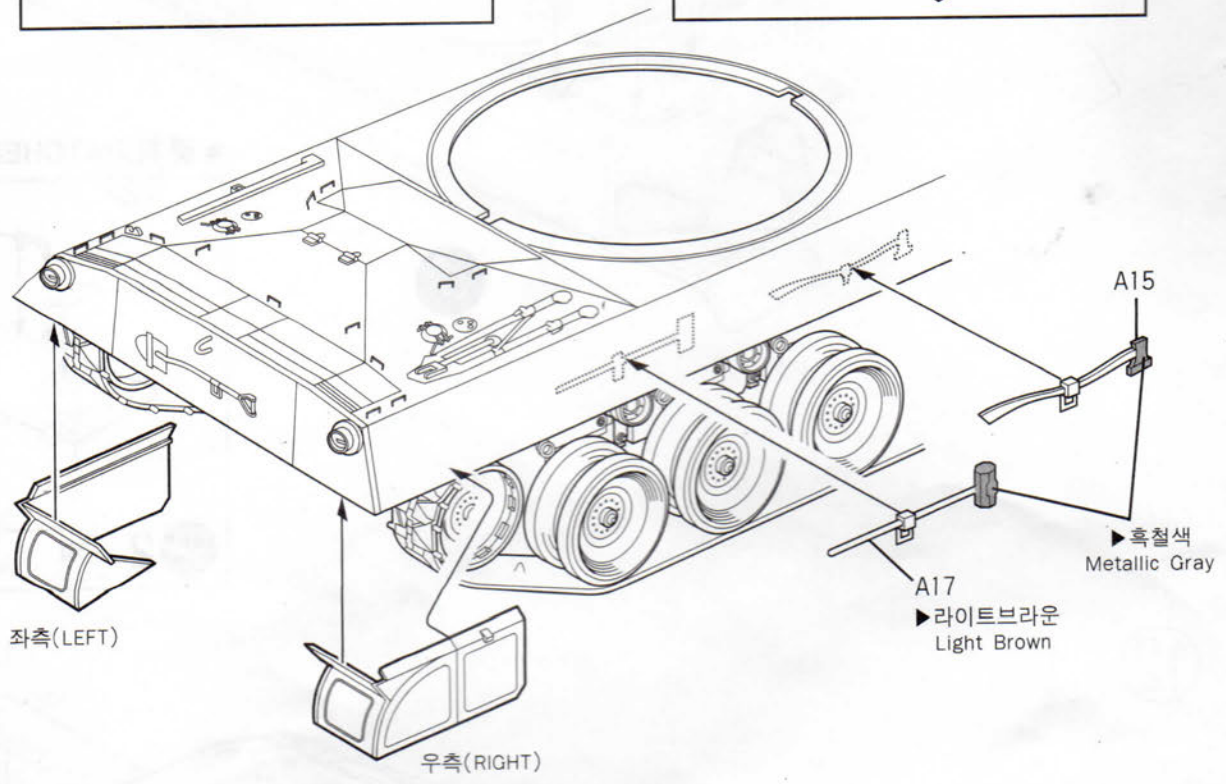
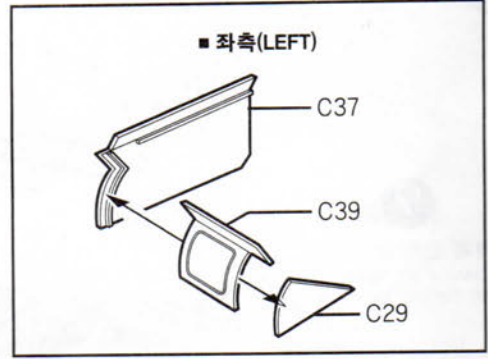
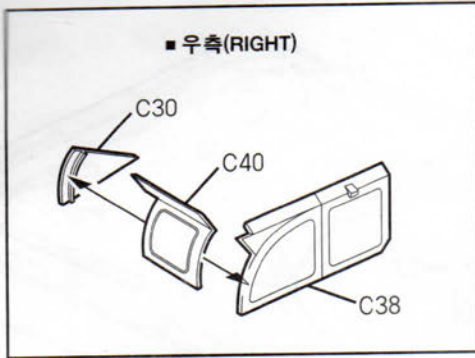

14

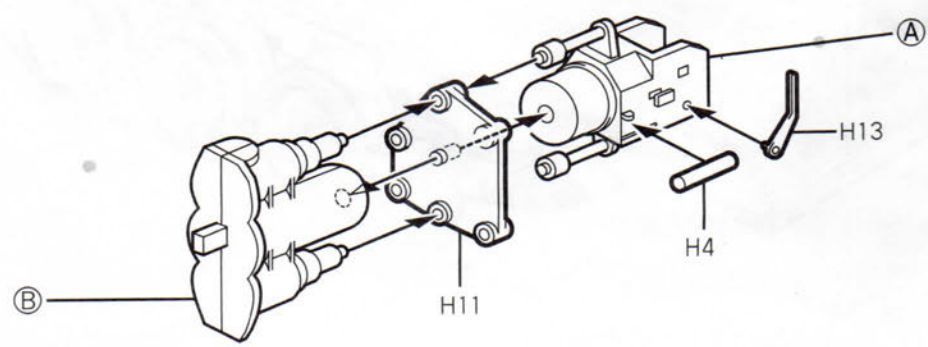
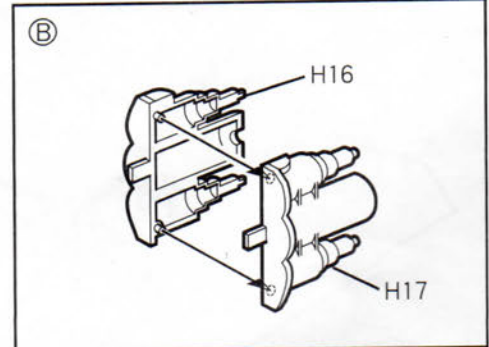
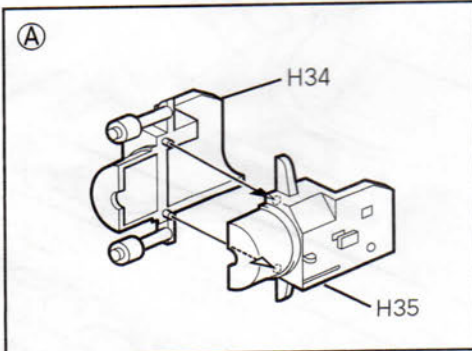

15

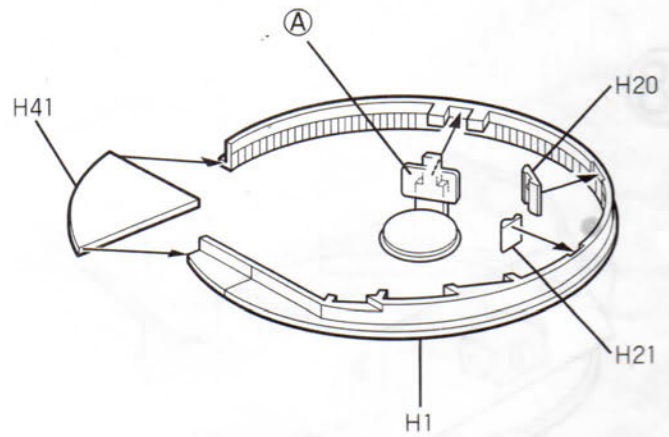
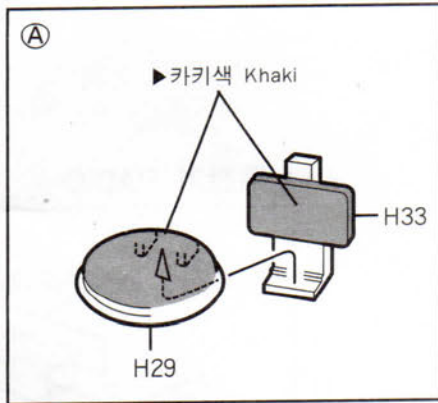
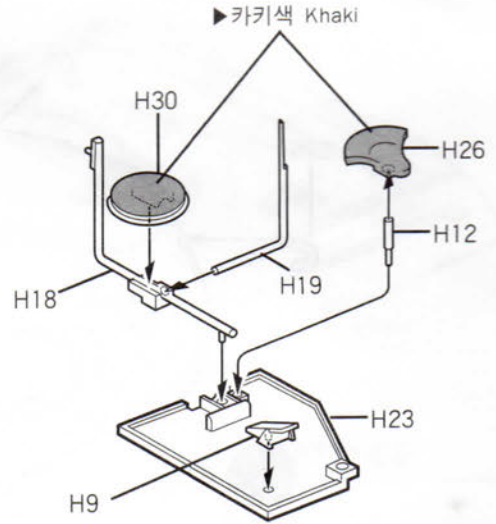
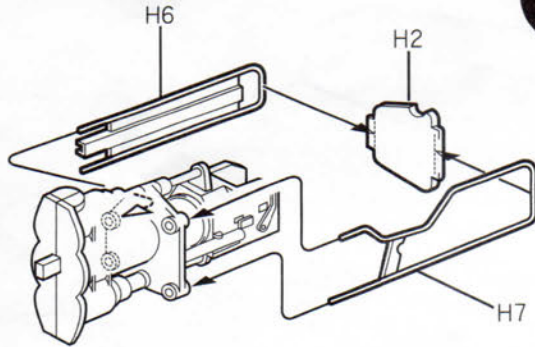

16

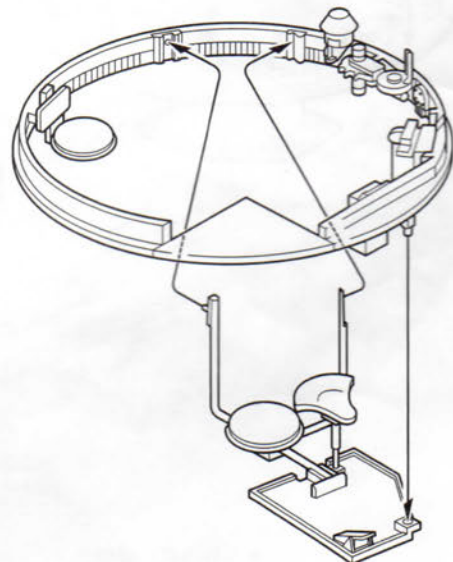
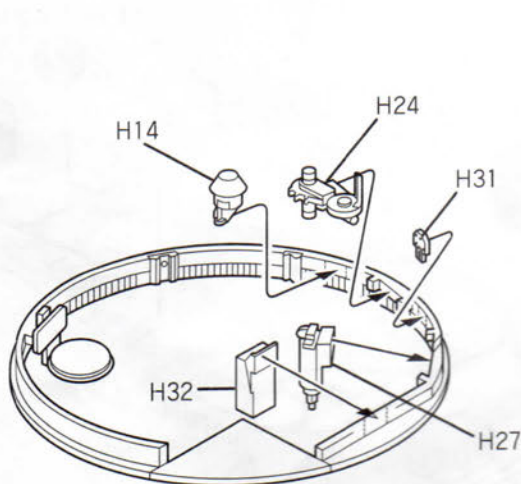

▶전체: 국방색
Overall: Olive Drab

17

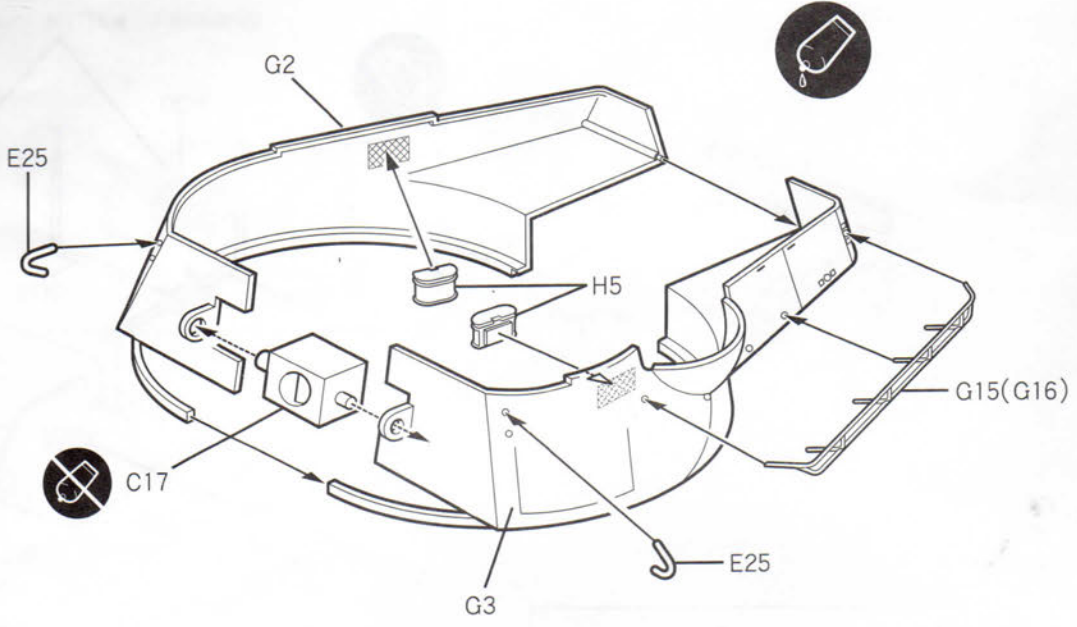

18

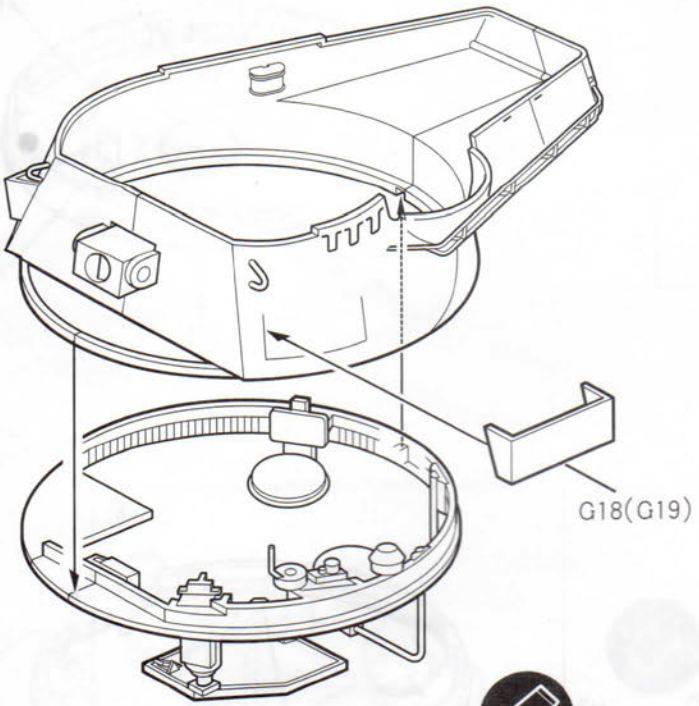

■ 무전기 RADIO

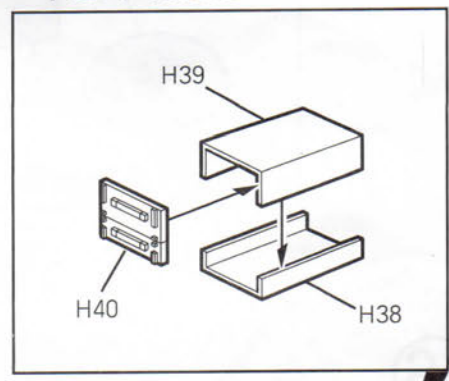

선택 조립한다.

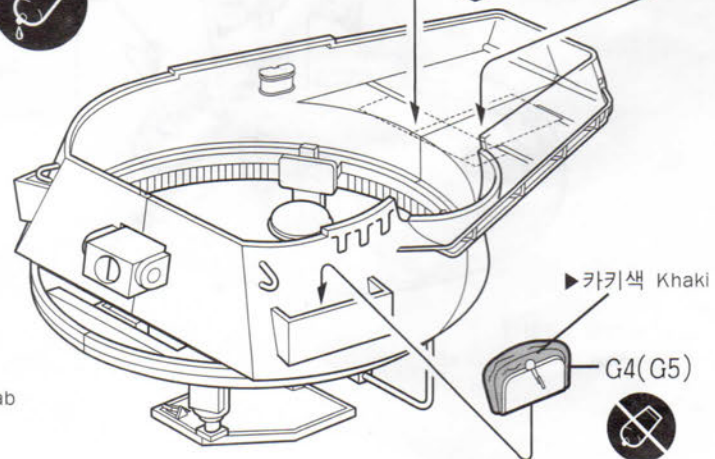
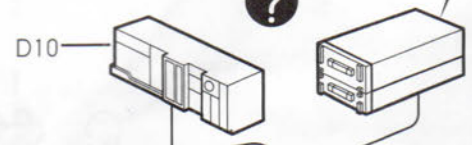

▶ 포탑내측: 국방색
Turret Interior: Olive Drab

▶ 카키색 Khaki

19

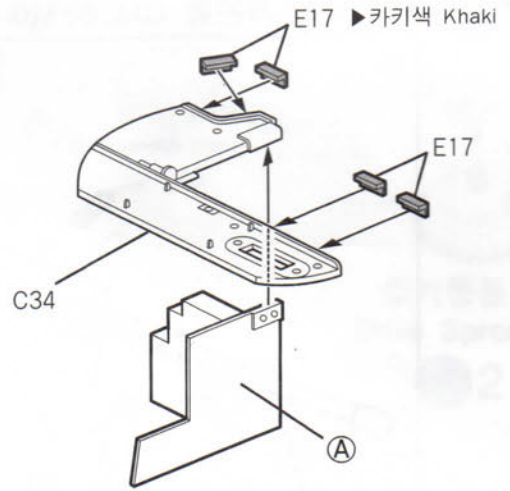
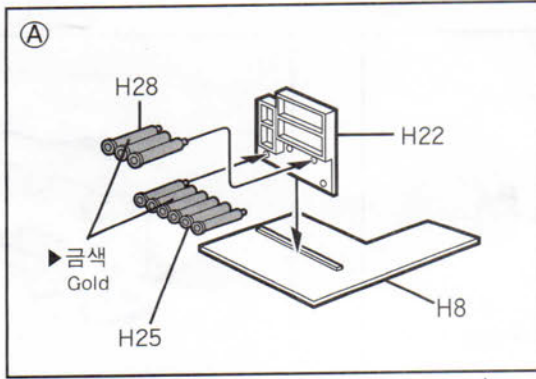

20

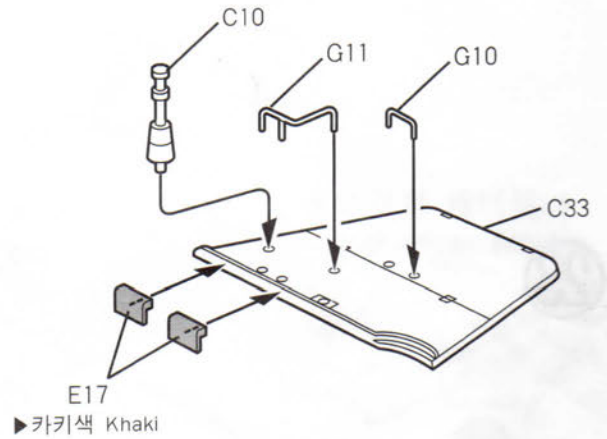
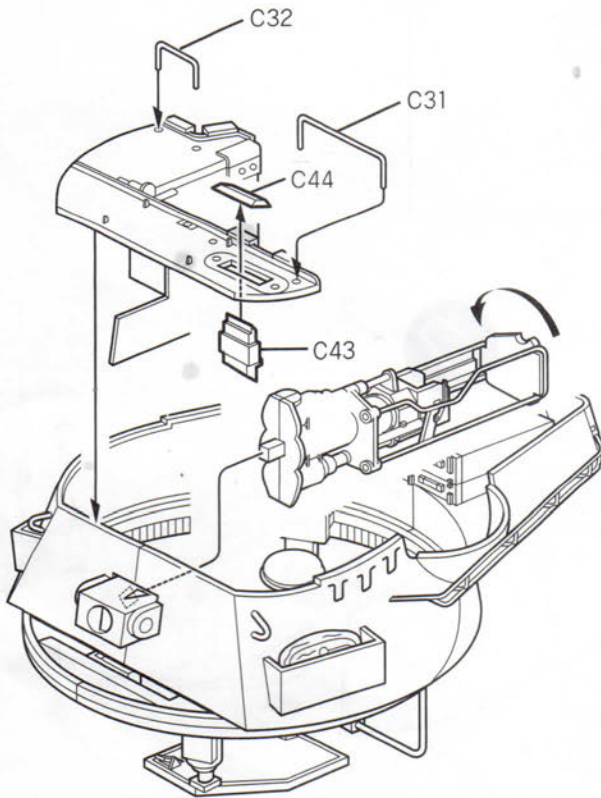

21

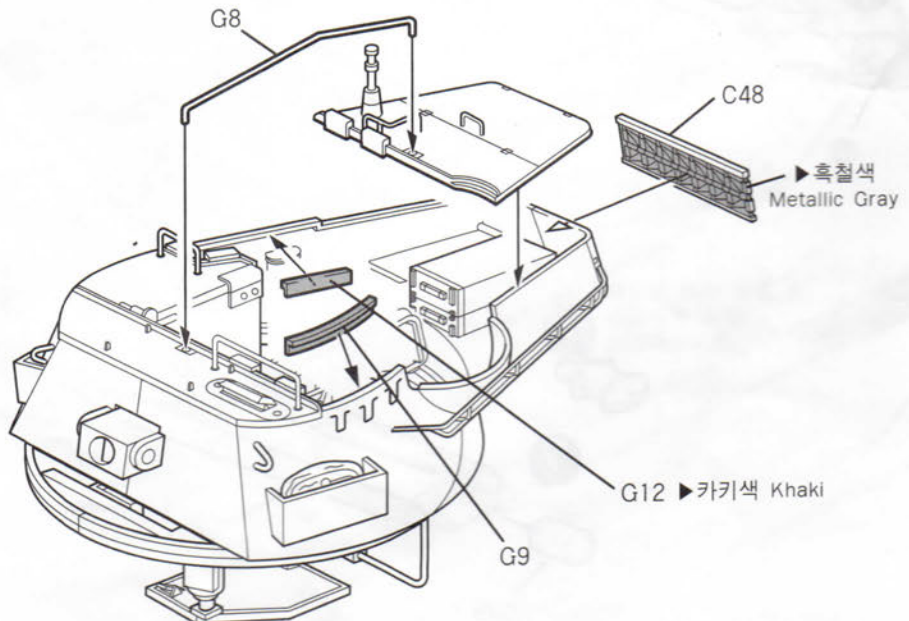

22

■ CAL.50 기관총 CAL.50 MG

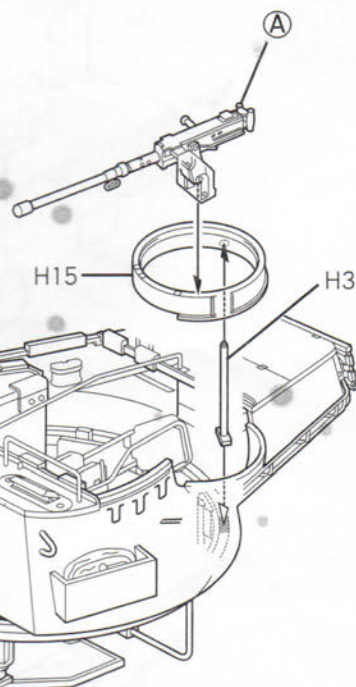
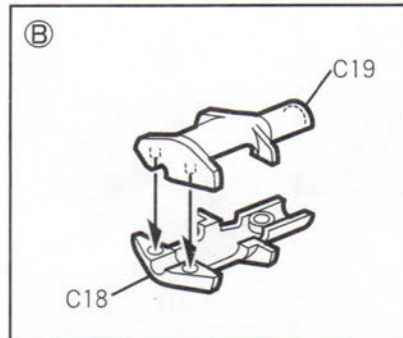
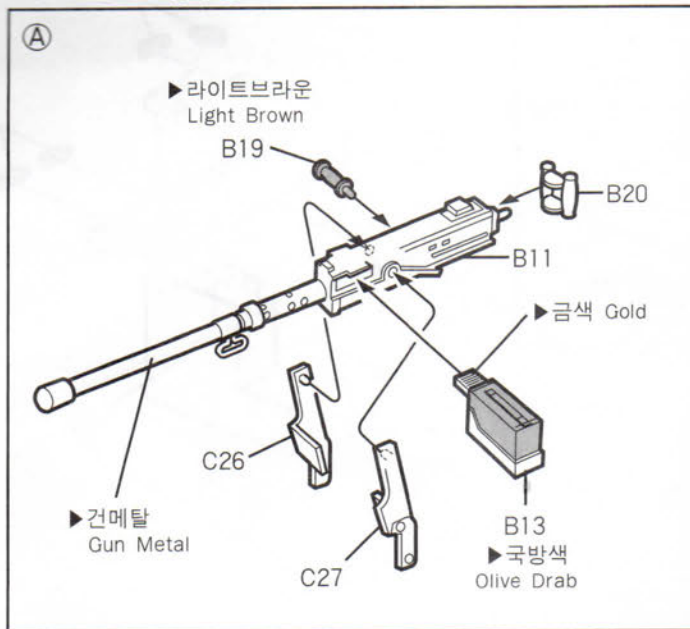

23

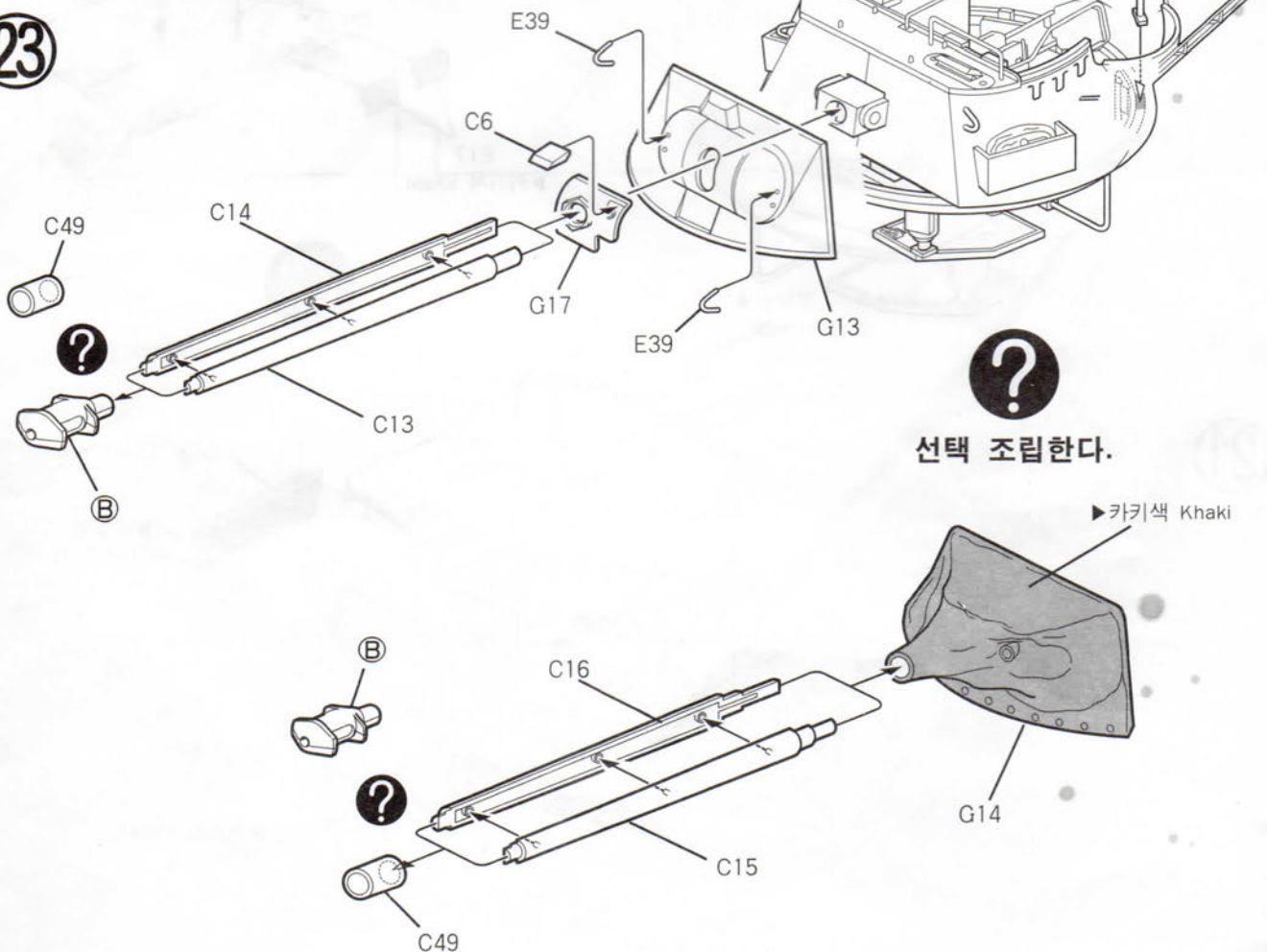

24

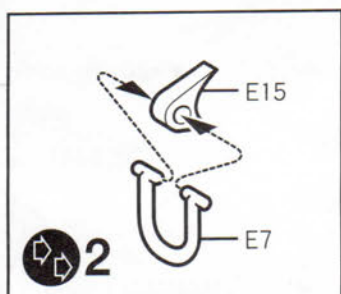

■ 후크 A HOOK A



선택 조립한다.

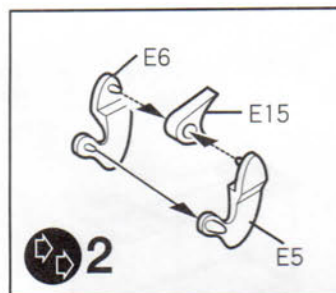

■ 후크 B HOOK B

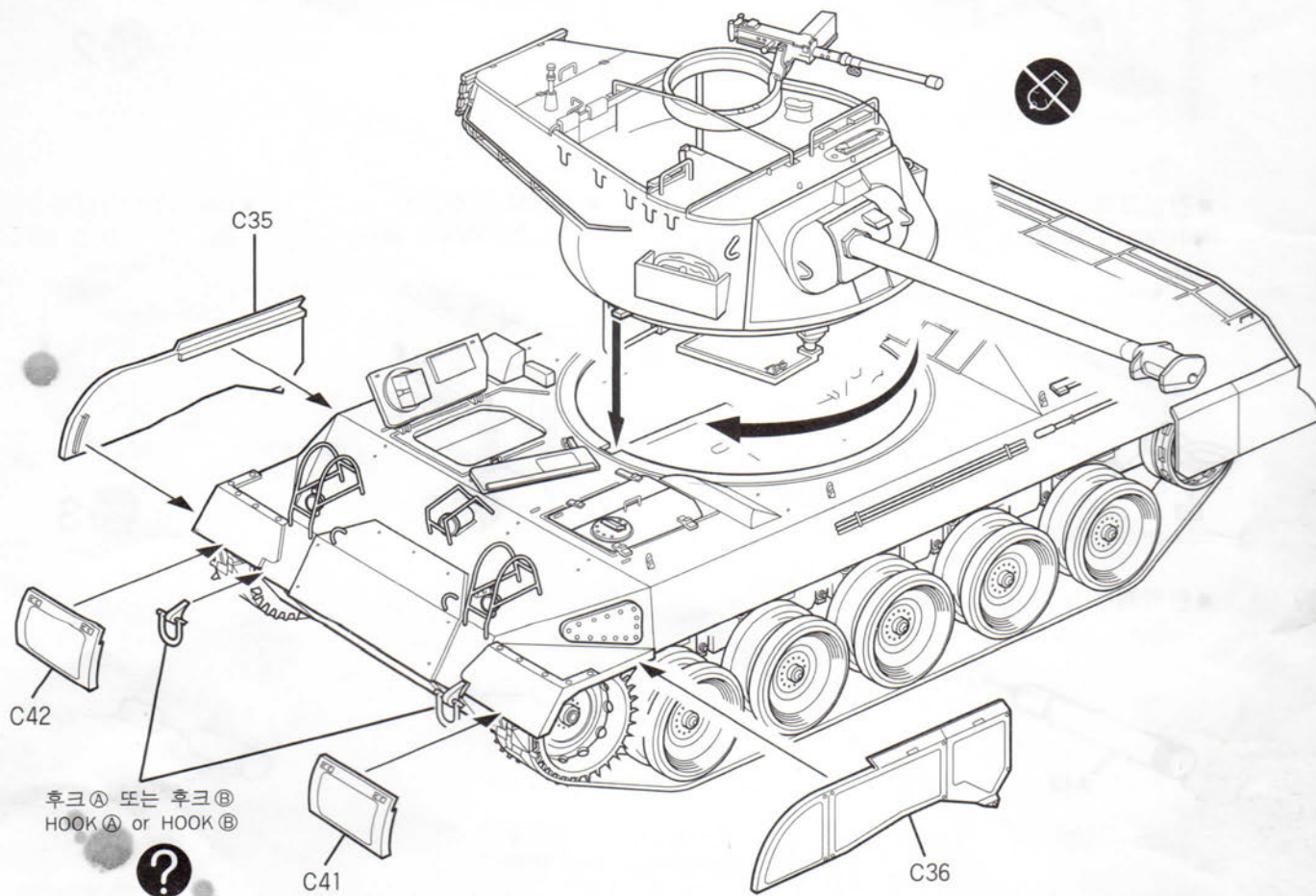

후크 A 또는 후크 B
HOOK A or HOOK B

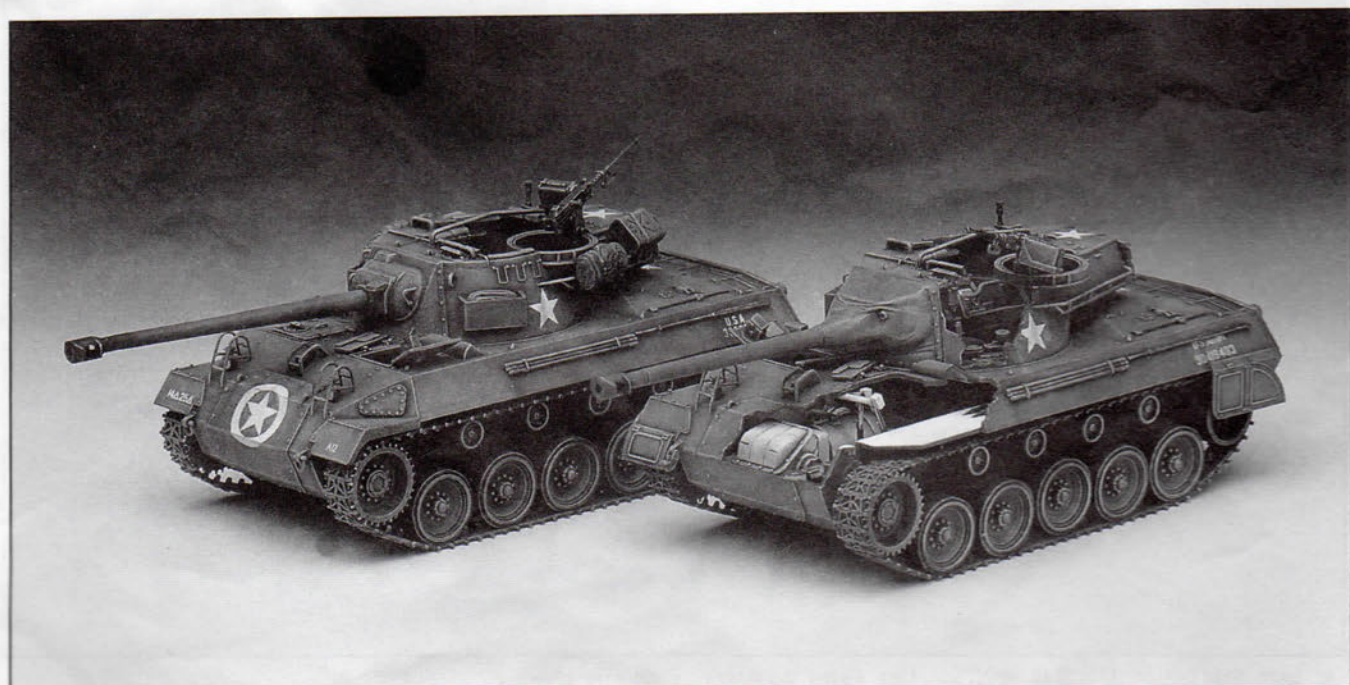

25

■ 75mm 탄약상자
75mm AMMO BOX

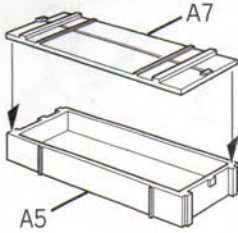

■ 76mm 탄약상자
76mm AMMO BOX

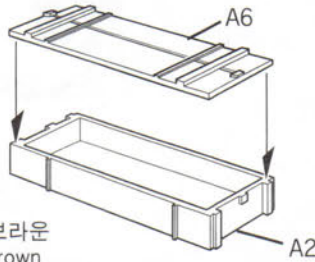

▶ 라이트브라운
Light Brown

■ 제리캔 JERRY CAN

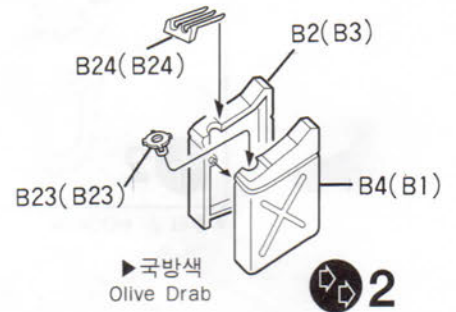

▶ 국방색
Olive Drab

2

■ 견인고리
TOWING HOOK

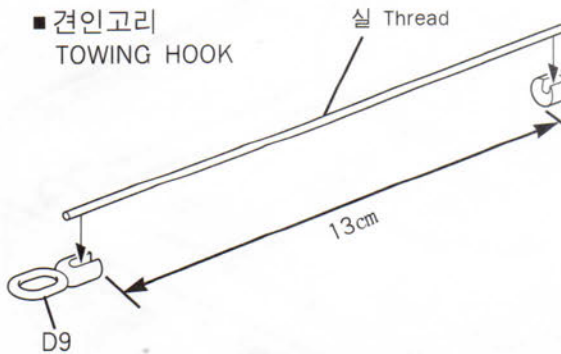

■ CAL.50 탄약상자
CAL.50 AMMO BOX

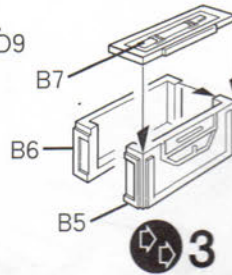

3

■ CAL.30 탄약상자
CAL.30 AMMO BOX

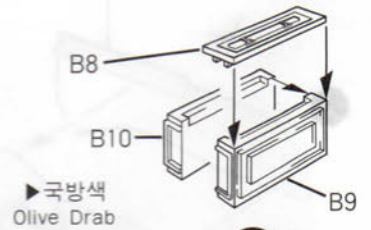

▶ 국방색
Olive Drab

3

■ 탄약케이스 AMMO TUBES

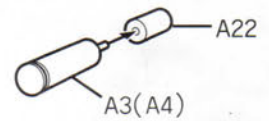
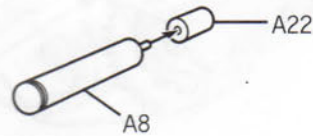
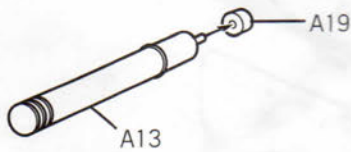

▶ 무광검정 또는 국방색
Flat Black or Olive Drab



* 남은 악세서리는 자유롭게 붙인다. Use Extra Accessories as you Like.

색칠 및 전사지 붙이기(Painting and Decal Placement)

■ 1944년 9월 프랑스 France on September 1944

■ 차체색:국방색
Body Color:Olive Drab

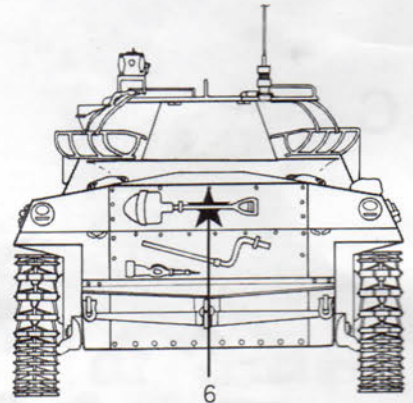
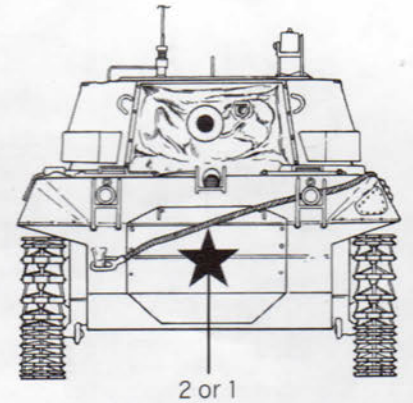
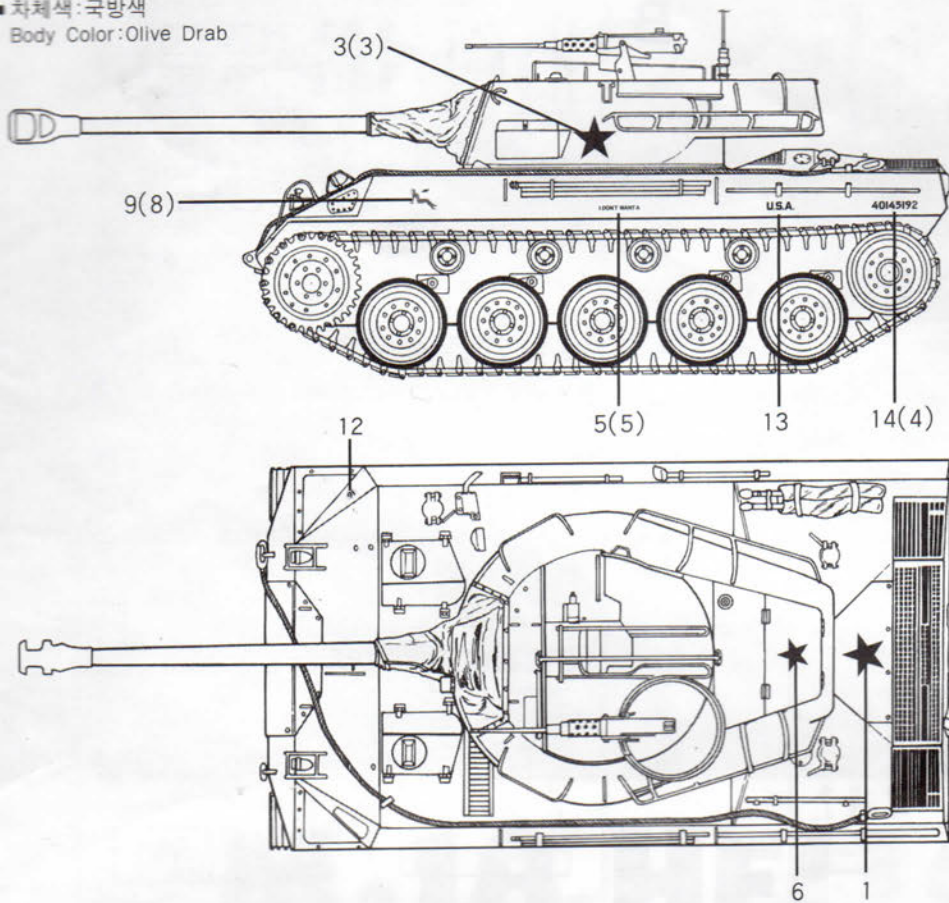

■ 1944년 12월 독일 Germany on December 1944

■ 차체색:국방색
Body Color:Olive Drab

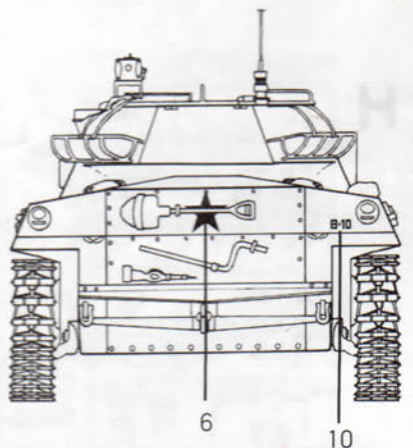
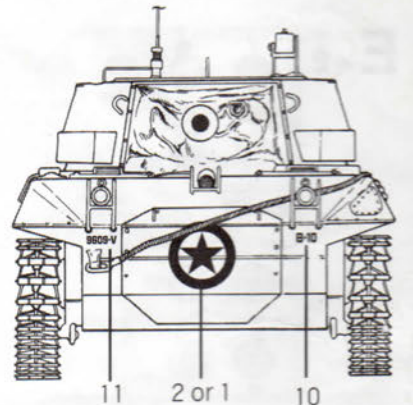
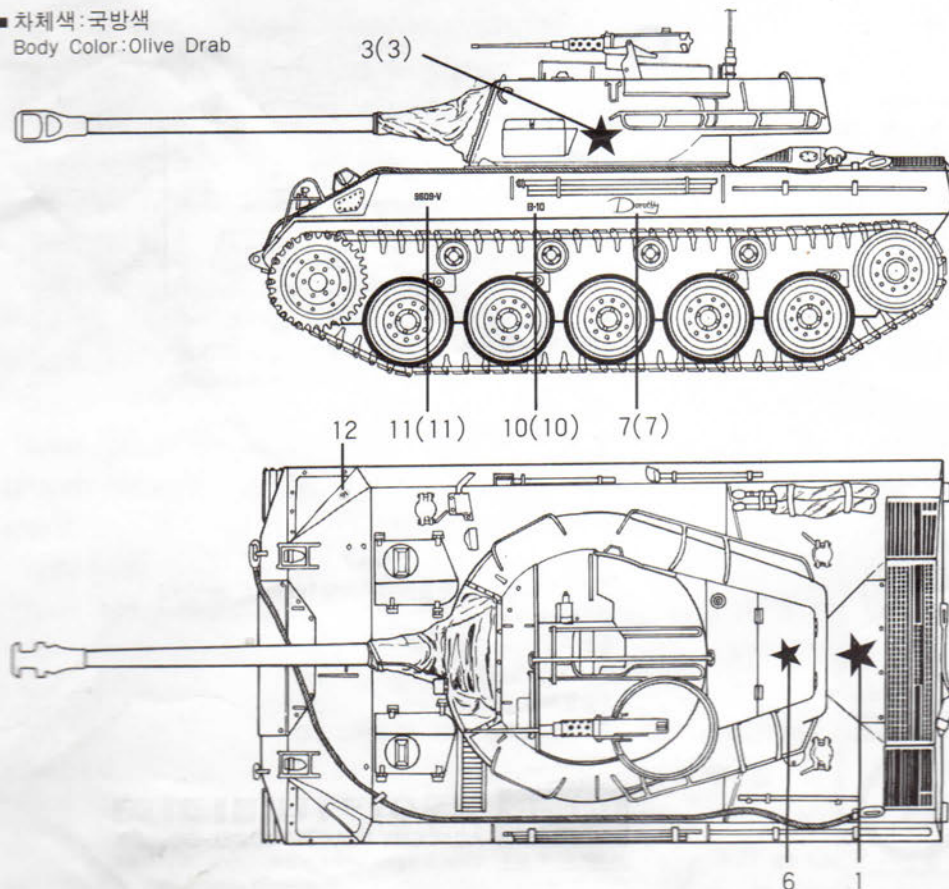

부품도 Parts Locating Diagram

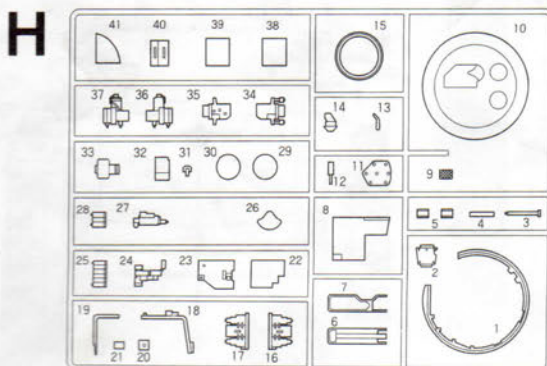
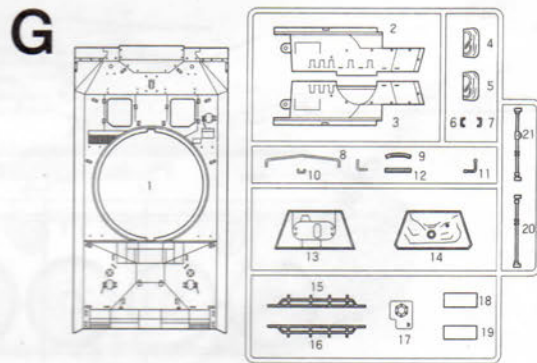
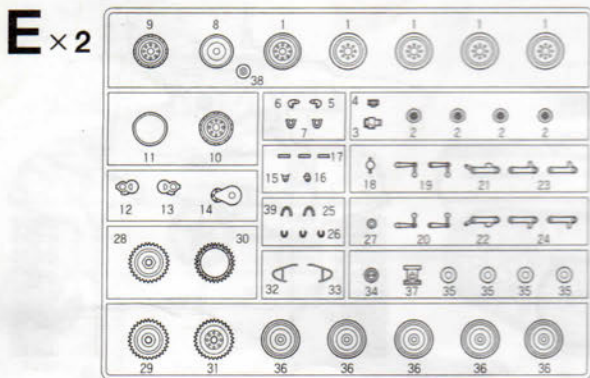
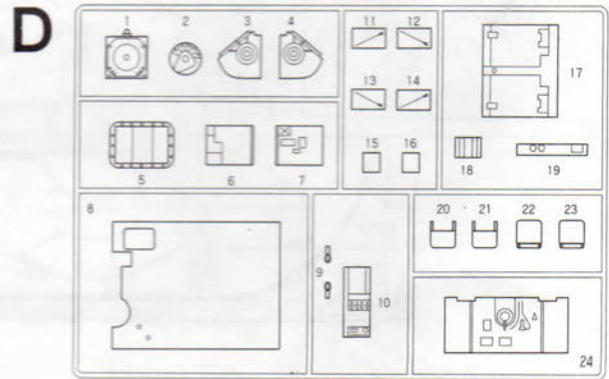
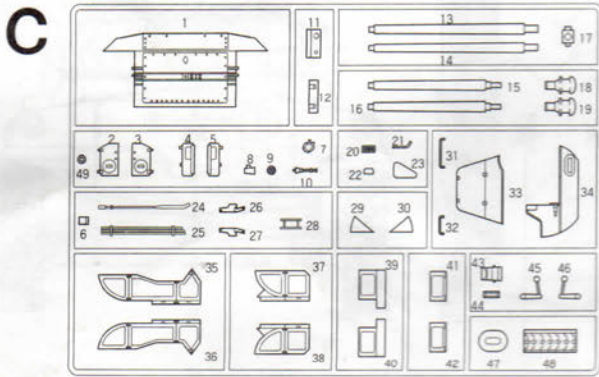
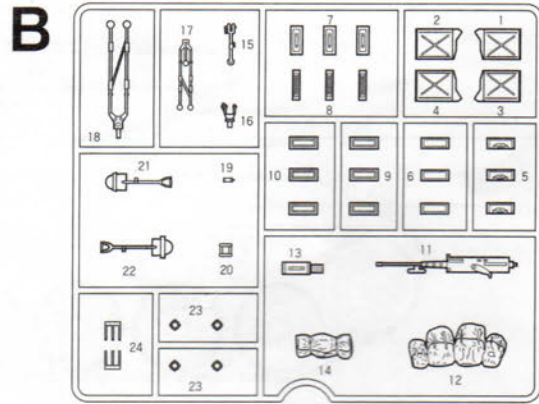
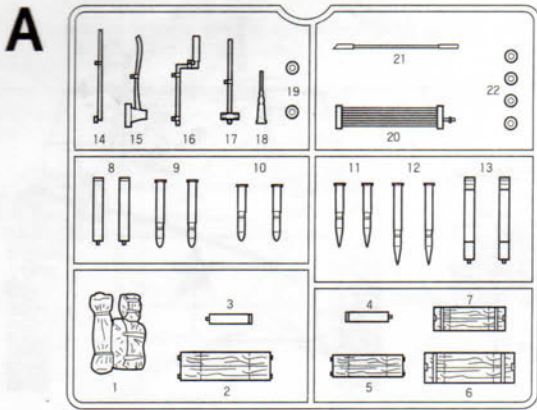

- 하체 Lower Hull × 1
- 연질캐터필러 Flexible Track × 2
- 연결식캐터필러 (F부품) Individual Tracks (F part) × 2
- 실 Thread × 1
- 폴리부품 Poly Cap × 1
- 전사지 Decal × 1

※ 불필요부품 Unused Parts
E21 × 1, E22 × 1, E28, E31, H10, C47

ACADEMY (주) 아카데미과학
ACADEMY PLASTIC MODEL CO., LTD.
HOBBY MODEL KITS 273-64, Suyu-dong, Kangbuk-gu, Seoul, Korea FAX: 82-2-997-3003