

1/35 Russian Artillery Tractor Komsomoletz T-20 Late Assembly Guide

this kits offers option to build either T20 Mod.1938 Late or T20 Mod.1940

Go through assembly guide before you start your work. Images in rows one by one show usually one small assembly step

Heat up PE parts with lighter before use, brass will soften and become easy to bend and work with Tamiya Super Thin Glue or Gunze Mr. Cement are recommended for plastic parts, let the glue work for a few seconds, then push parts together, melted plastic will fill the gaps between parts. You can also melt sprue frame and use it as an amazing filler for small works, or use this glue to wash out tiny seam lines on little parts or make texture on some parts etc.

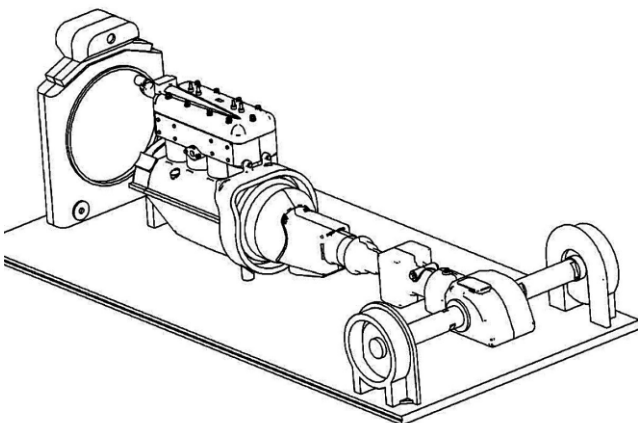
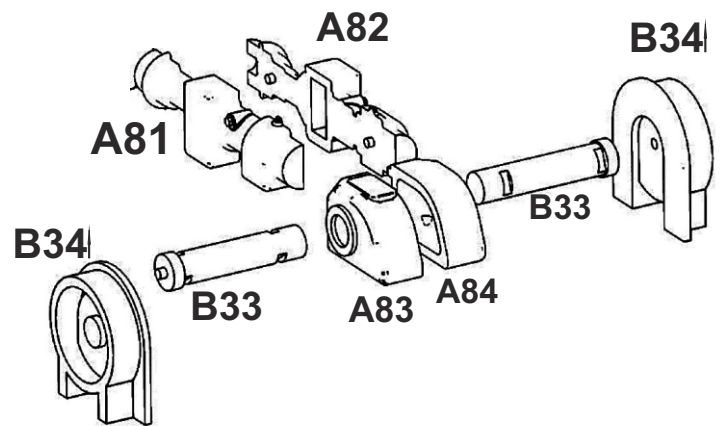
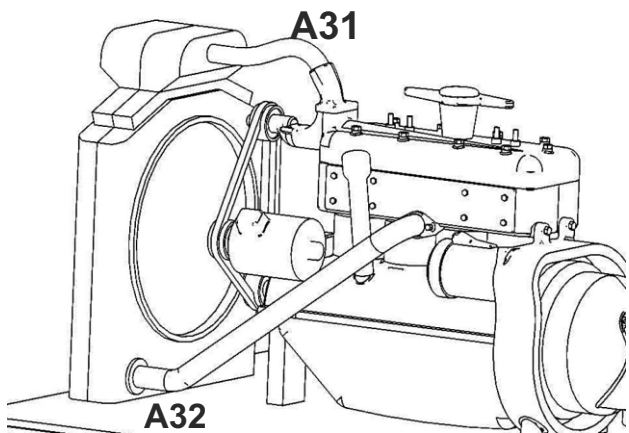
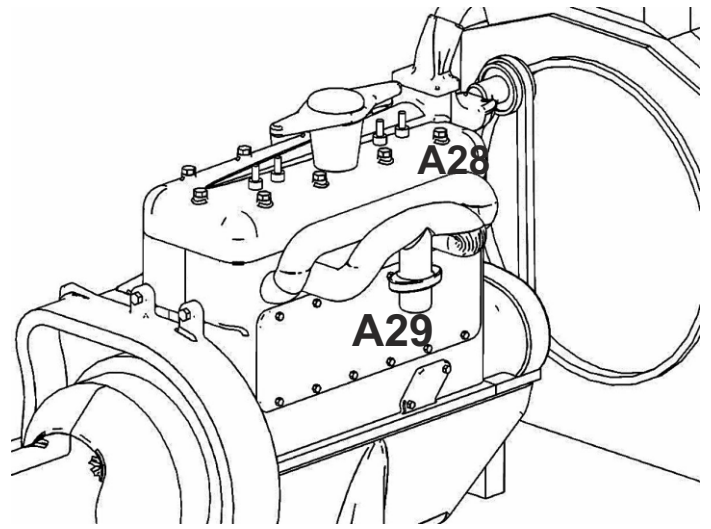
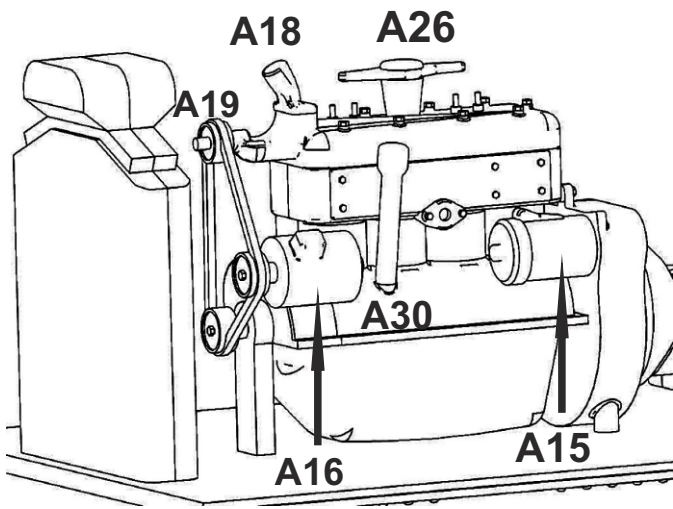
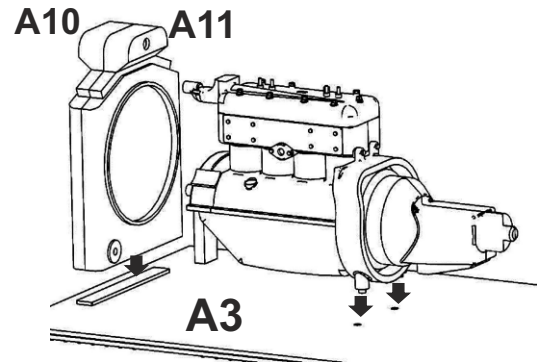
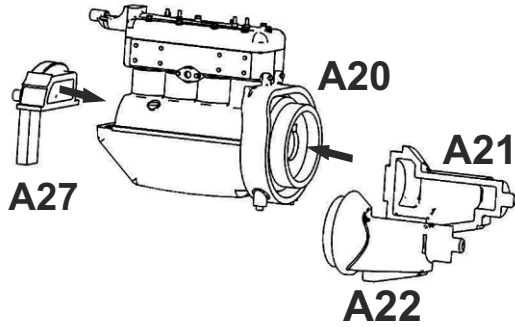
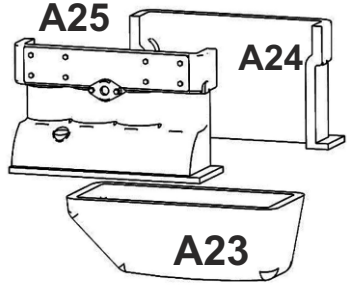
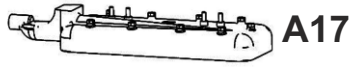

K24

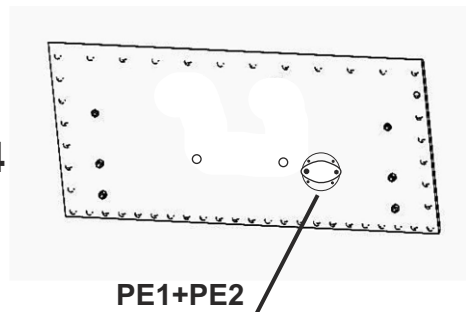

PE1+PE2

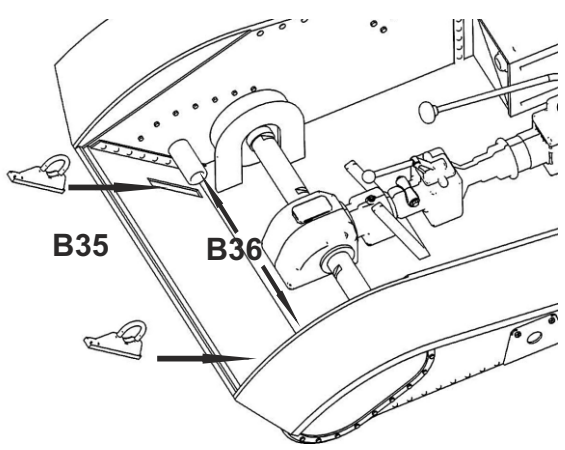
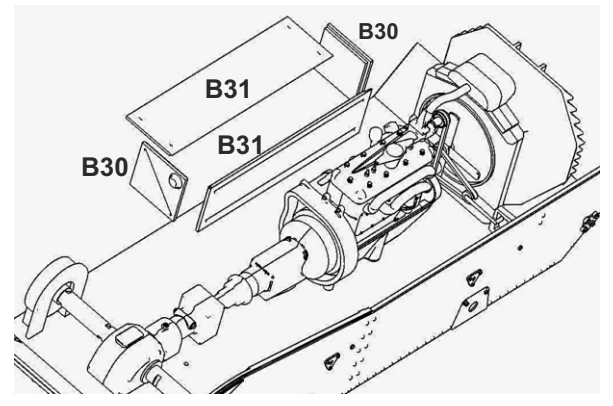
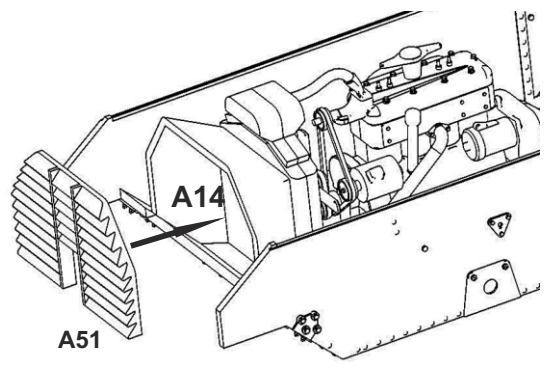
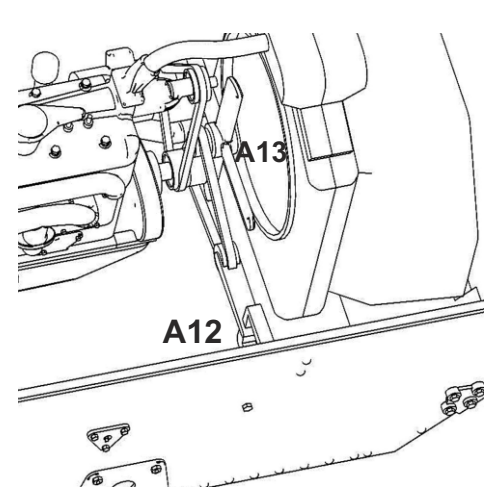
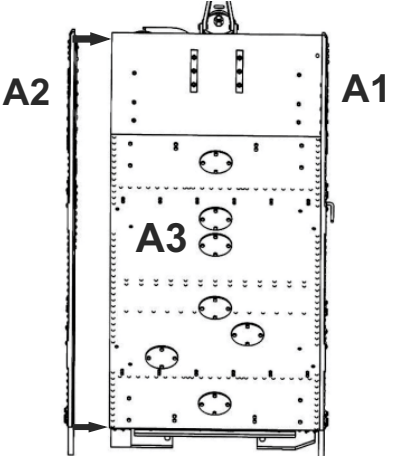
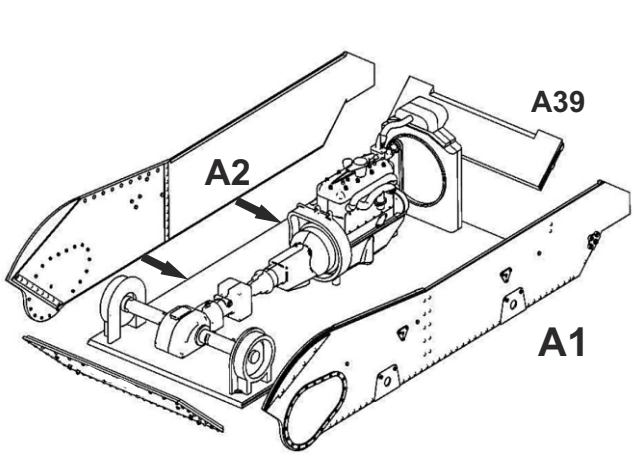

use K17 for 1938 late or K12 for 1940 variant

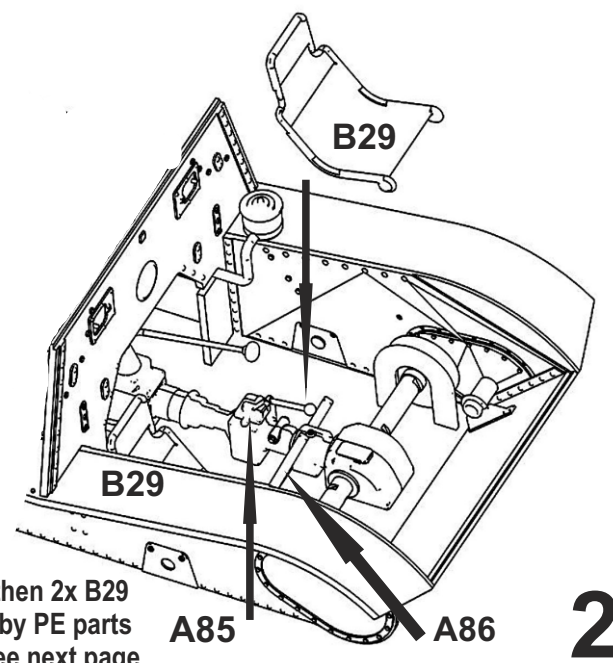
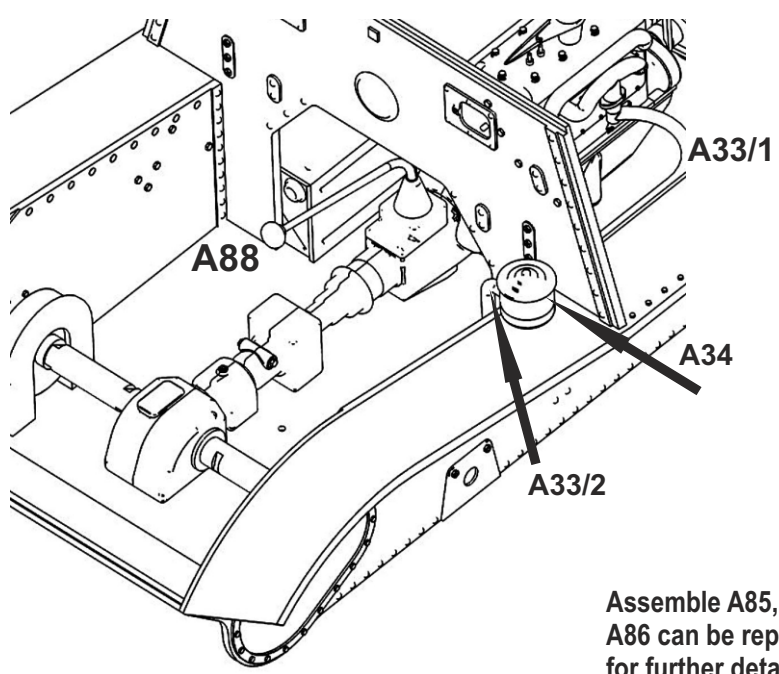
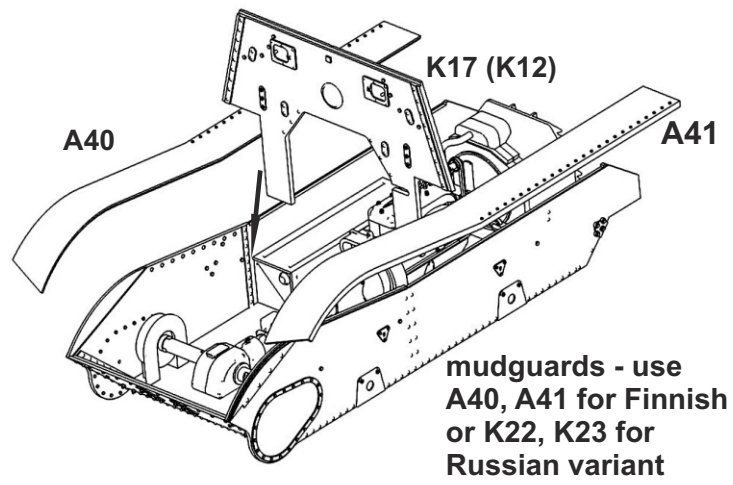

Assemble A85, A86, then 2x B29
A86 can be replaced by PE parts for further details - see next page

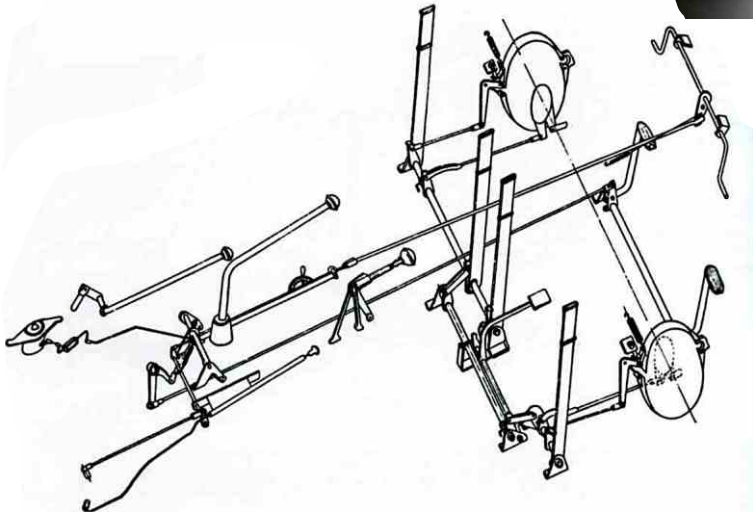
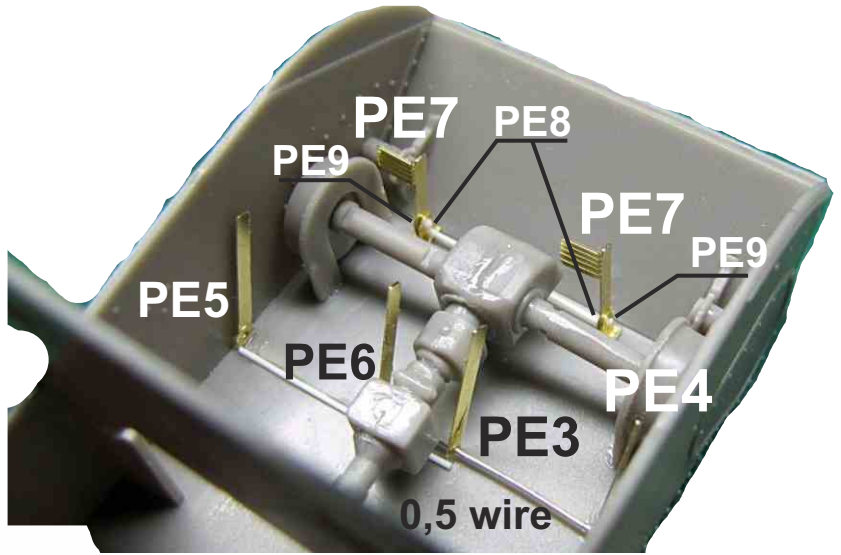
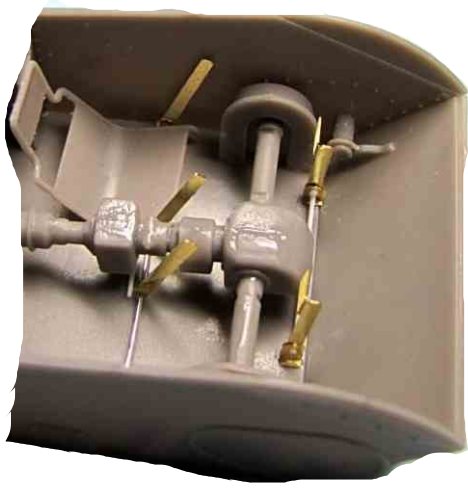

Interior diagram

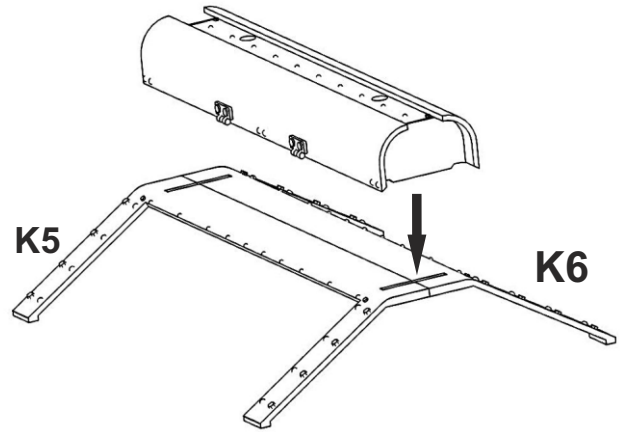
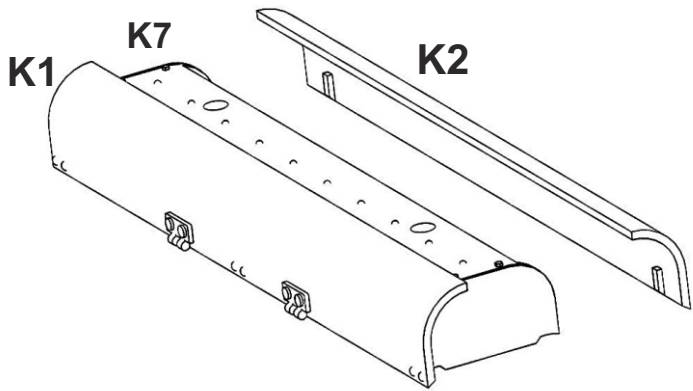

assemble K20, K21 first, then place engine cover

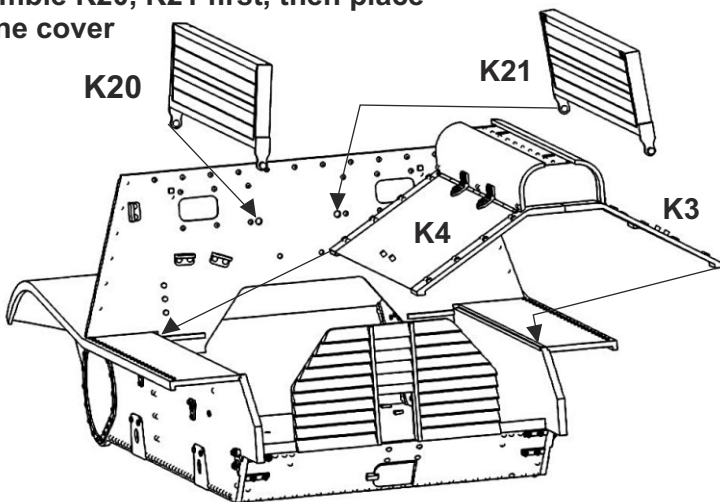

Benches can be assembled in any position required

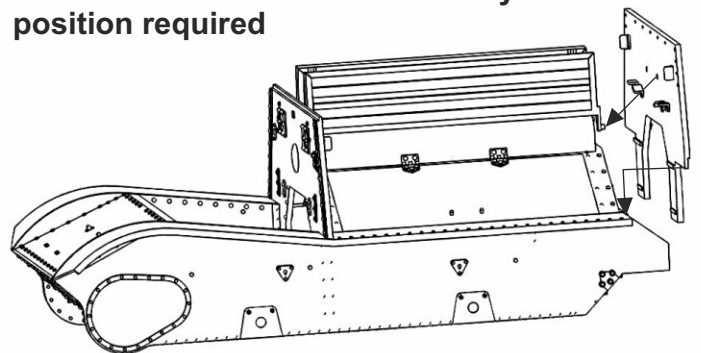

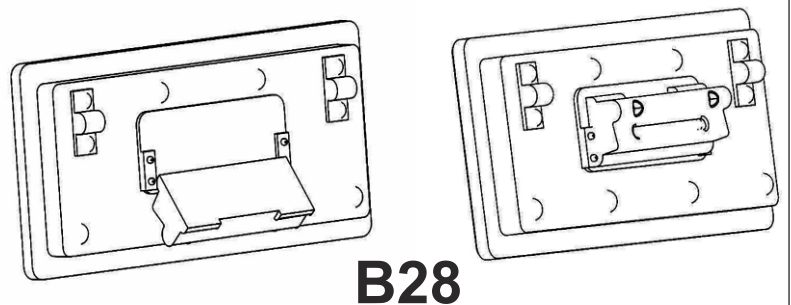
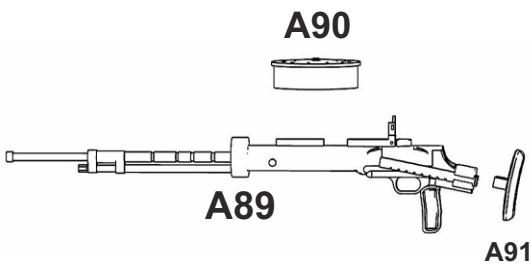
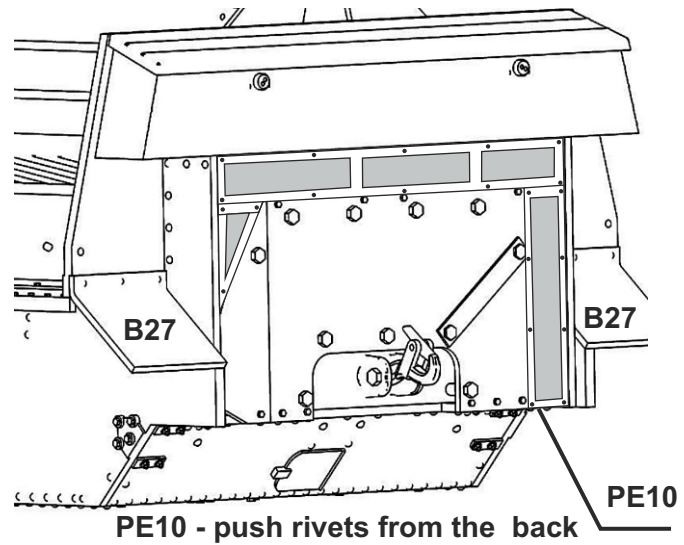
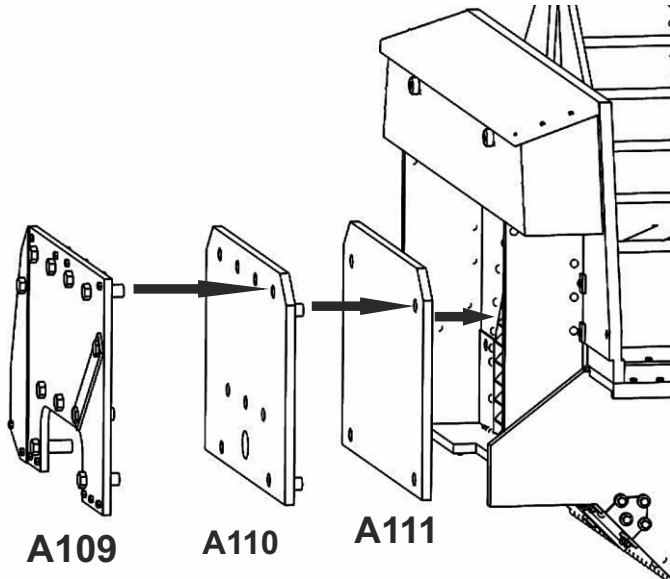
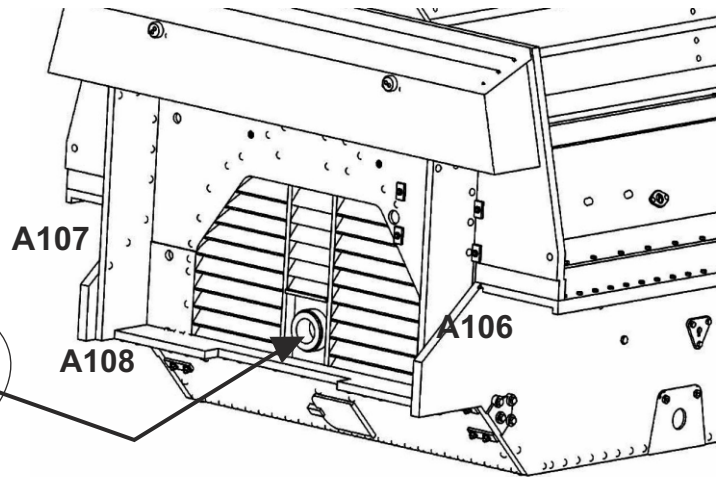
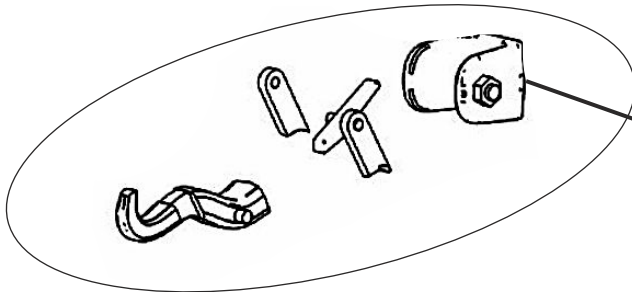
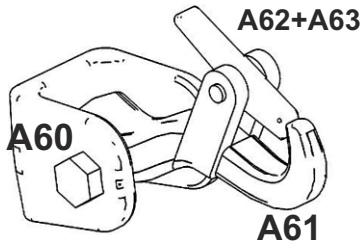
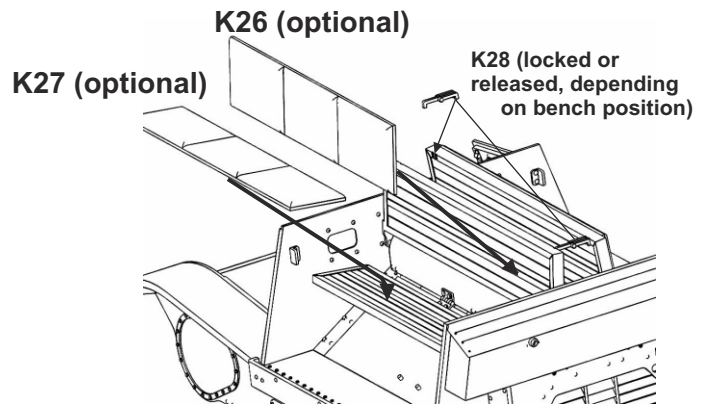
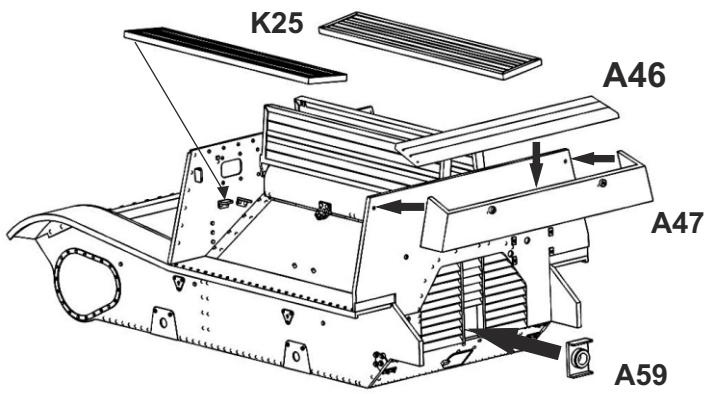

INNER SHUTTERS B28 CAN BE ASSEMBLED EITHER OPEN OR CLOSED

Some parts are different for Mod.1938 Late and Mod.1940 options.
 Note - parts used only for Mod.1940 are written in brackets ()

K10 A92 K9 A93 A95 K11 (K15)

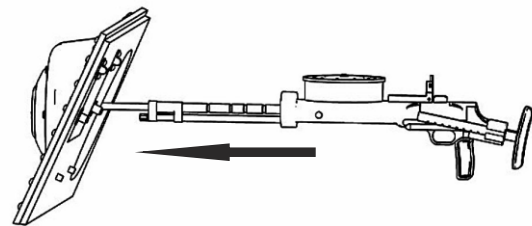
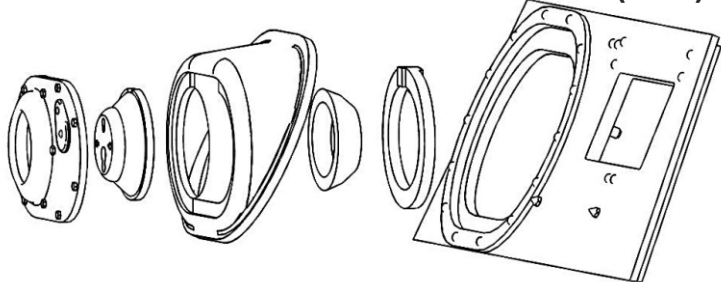

MAIN SHUTTERS CAN BE ALSO ASSEMBLED CLOSED IN ANY OPEN POSITION

- in that case SET B32 ACCORDINGLY

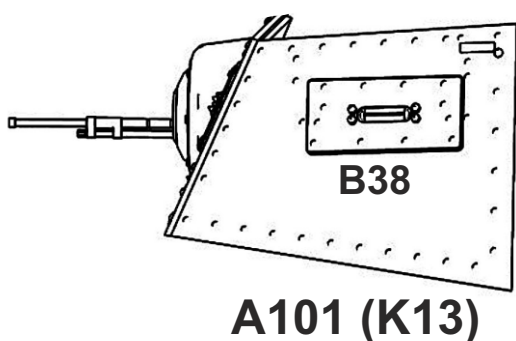
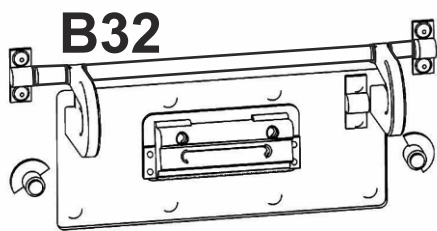

“XX”

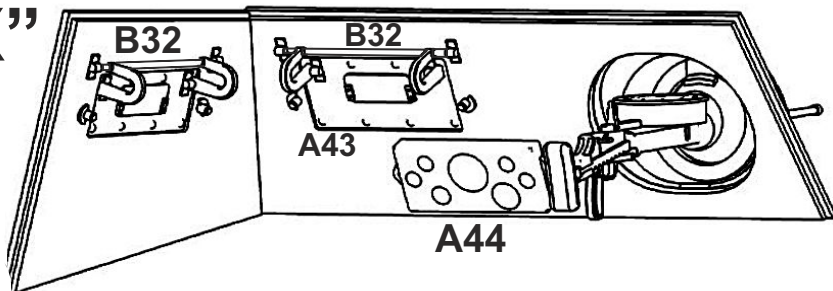

Assemble A42 before you place “XX”

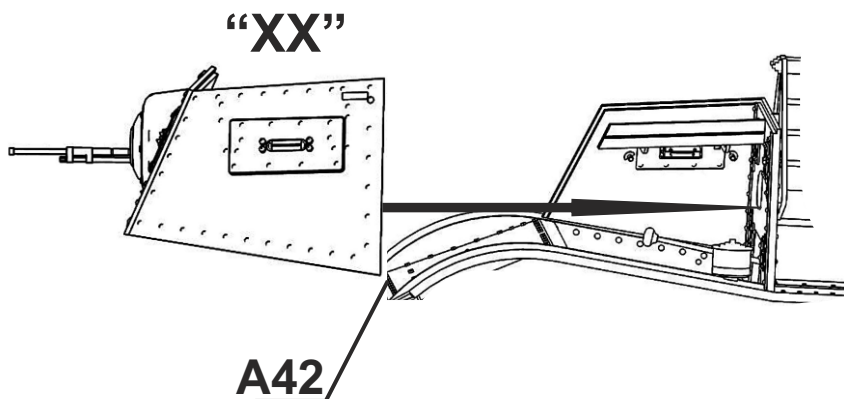
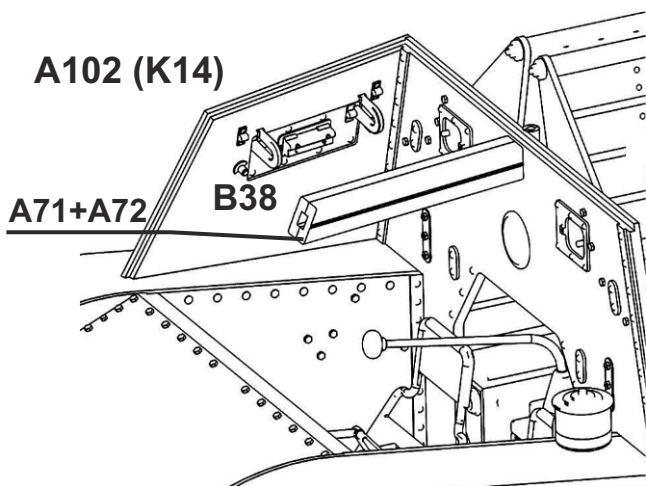

Russian tractors were painted in Russian green, no further marking shown in photos, just one source mentioned Russian Red Star on the front hull.
 Captured tractors in German service had mostly original Russian paint, some sources mention tractors painted in Panzer Grey
 Finnish service tractors were painted in dark green, often in combination with lighter green

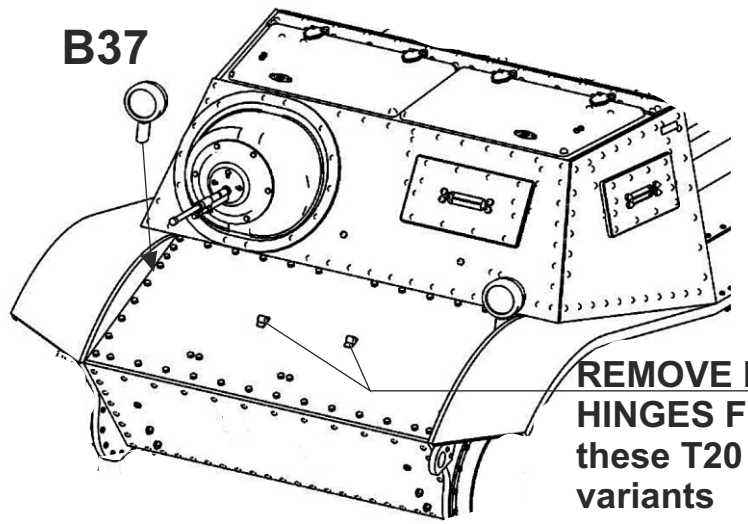
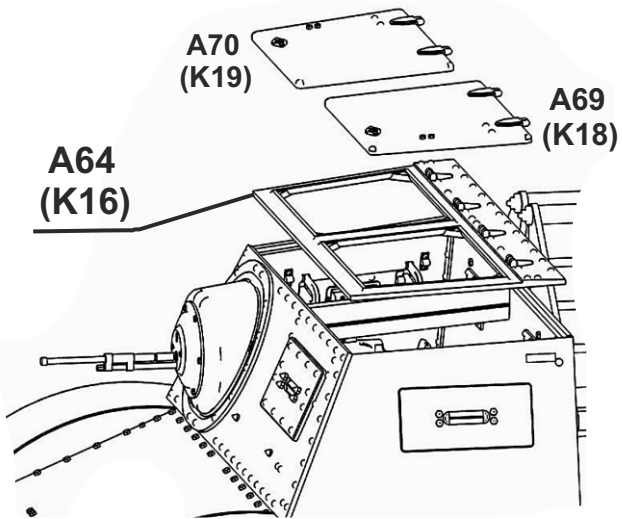

REMOVE both HINGES FOR these T20 variants

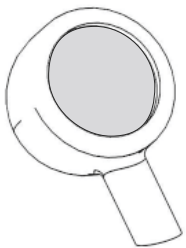

Paint lights inside in silver, then apply drop of thick clear varnish to make glass. Depending on varnish used, you might need to repeat it a couple times

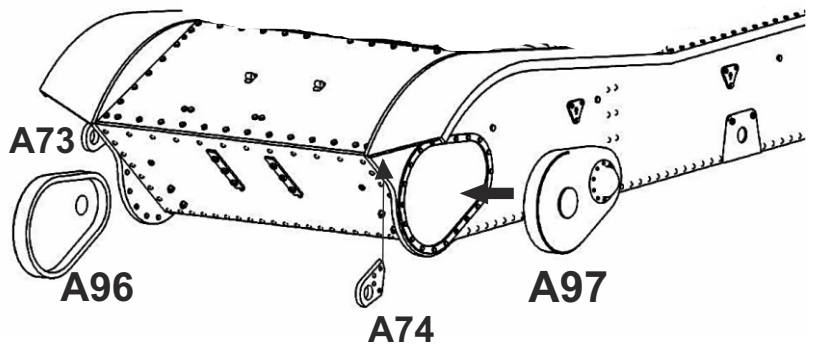
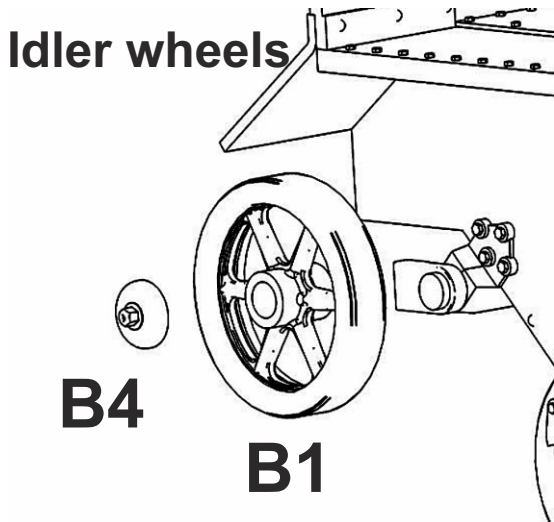
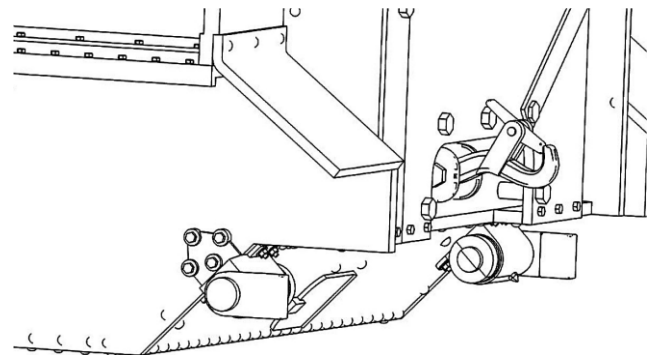
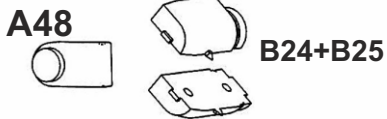
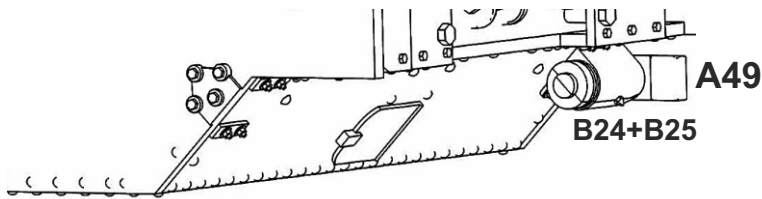

Make 4 bogies, 2+2 have very same parts

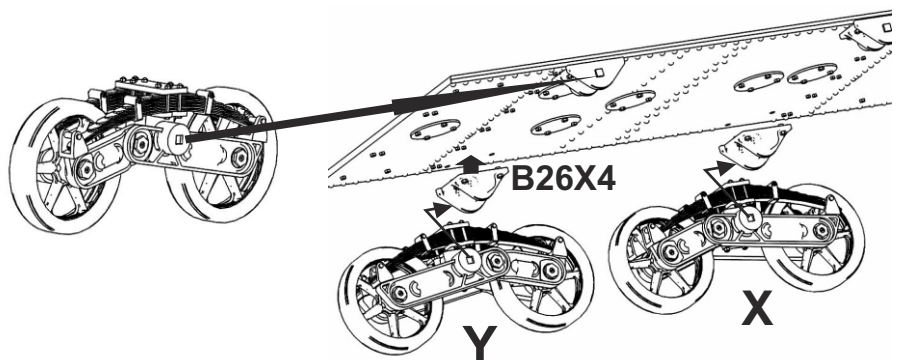
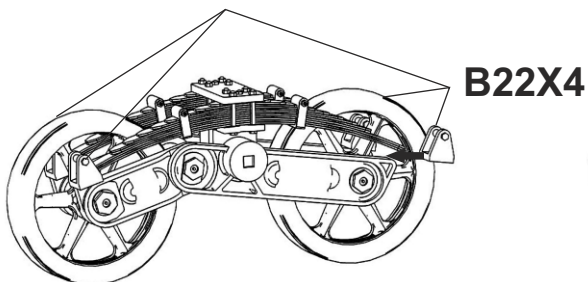
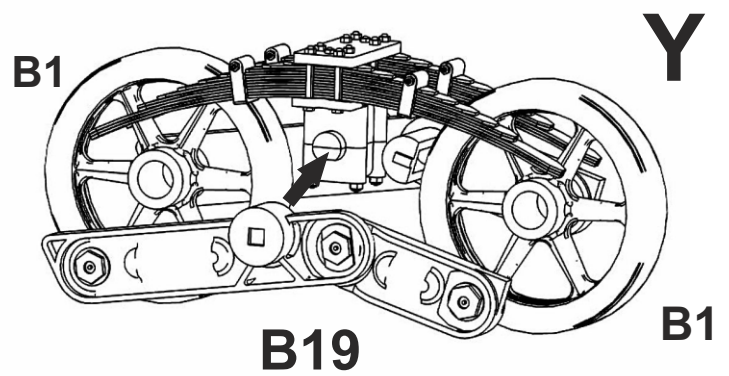
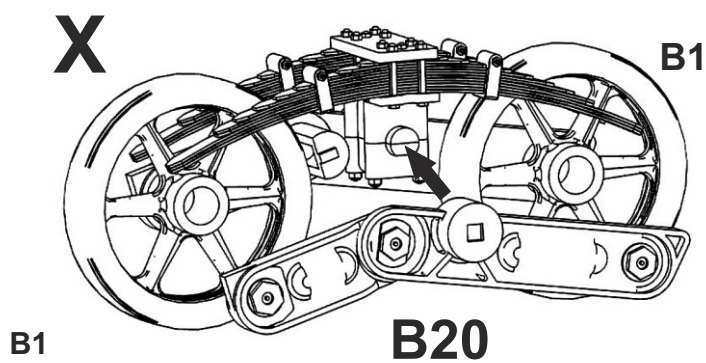
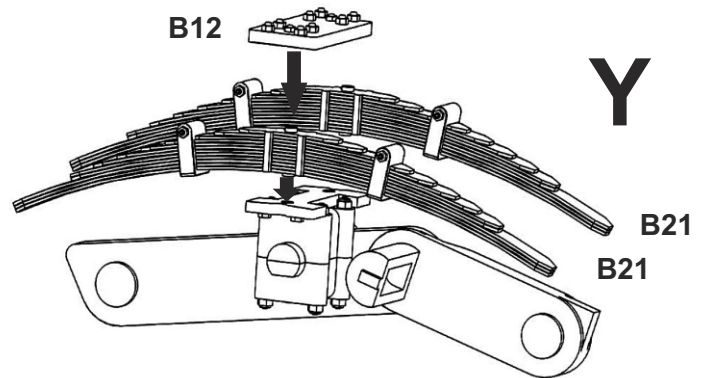
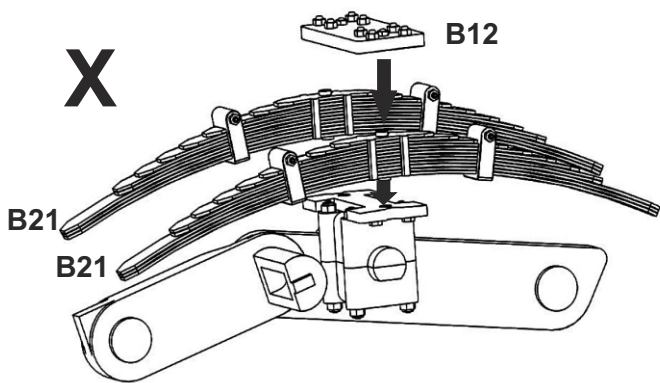
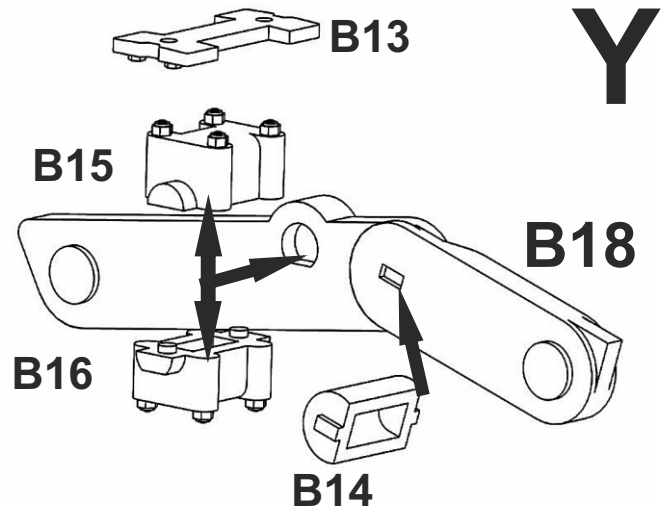
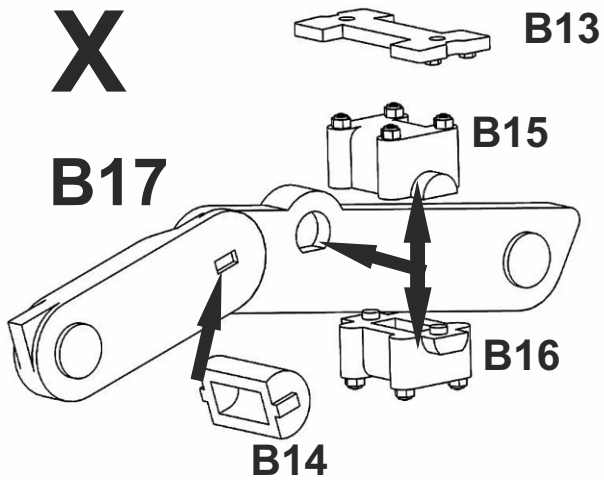

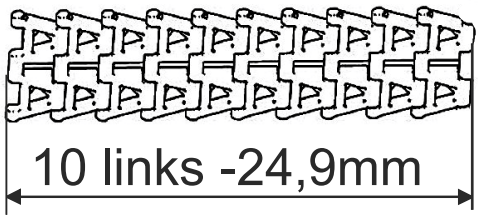
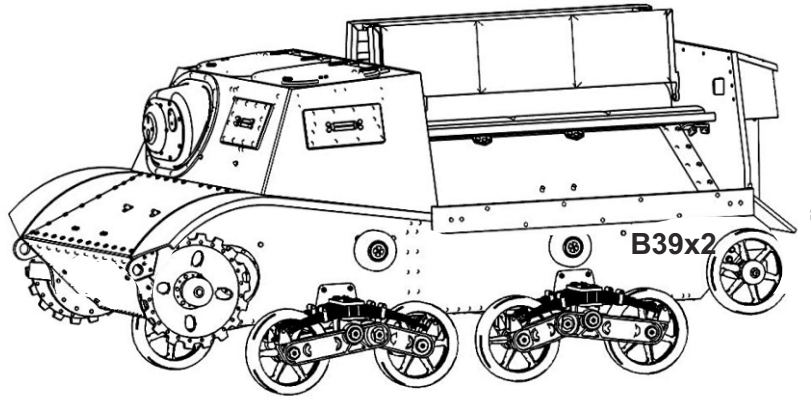
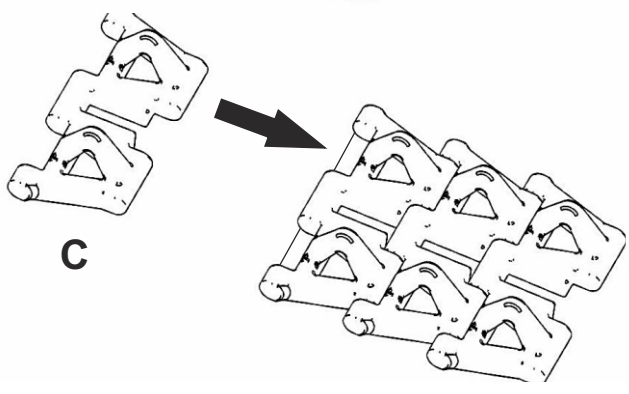
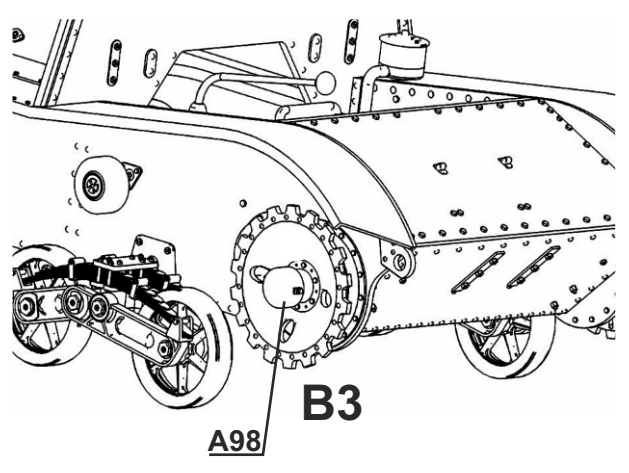
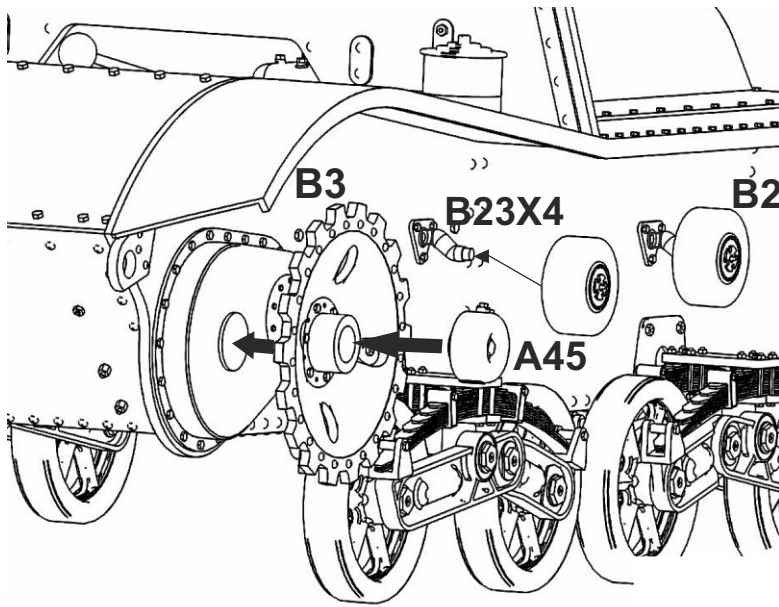

Keep checking length of the tracks during assembly, do not leave gaps between links

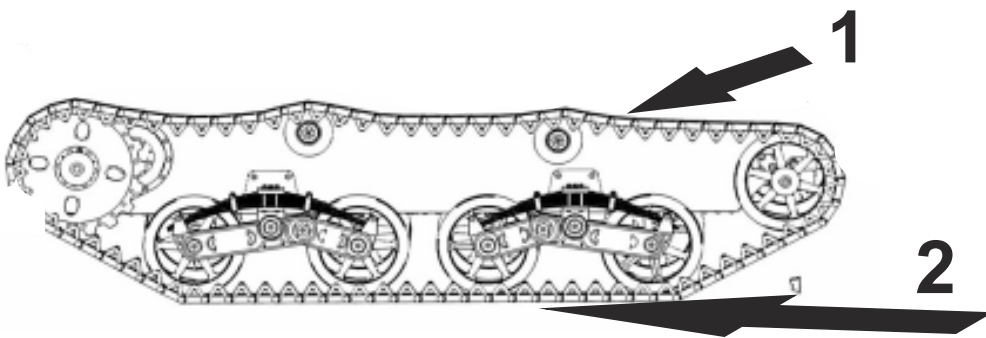

it is easier to assemble top first and then bottom

Track assembly, 78 links per track, tractors had trouble with falling tracks often, some references mentioned that a tracks were sometimes shortened to 77 links to improve this issue

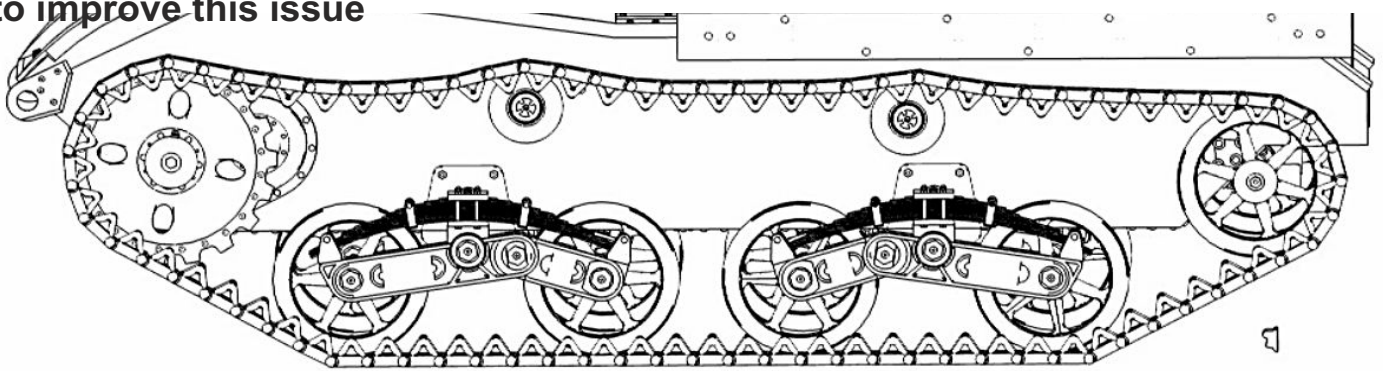

Besides Mod.1937 Late and Mod.1940 this kit contains also all the parts to build 2 early options, Mod.1937 and Mod.1938 Early (Russian and Finnish service). In case of interest in these you can download assembly guide for early variants here: http://mirror-models.websnadno.cz/35200/t20_early_assembly_guide_updated.pdf