

A-20J/K Havoc

"last bomber version"

Kit No. 72564

1/72

HISTORIE

Ⓒ A-20G byla první opravdu masově vyráběnou verzí Havocu pro letectvo US Army. Oproti starším verzím byla redukována osádka na dva členy, přid' byla zaplechována a byla do ní soustředěna zesílená hlavňová výzbroj. První výrobní bloky A-20G-1 až G-15 dostaly výzbroj čtyř kanonů M1 a dvou kulometů ráže 12,7 mm a měly ještě původní provedení nekrytého střeliště. Protože došlo k nárůstu hmotnosti, a kanony M1 se při delších dávkách zasekávaly, nebylo s výkony prvních A-20G letectvo US Army spokojeno. Dvěšestpadesát kusů této verze dostal Sovětský svaz. U ostatních strojů byly kanony nahrazeny kulomety. Nejpozději od výrobního bloku A-20G-20 byly dodávány Havocy standardně s šesti kulomety ráže 12,7 mm v přídí a s do rozšířeného trupu instalovanou střeleckou věží Martin se dvěma kulomety ráže 12,7 mm. Další bloky byly shodné.

Na základě bitevní verze A-20G byla pro evropské bojiště vyráběna bombardovací verze A-20J. Ta se vrátila k prosklené přídí s pracovištěm navigátora-bombometčíka. Tyto letouny byly používány i jako vedoucí stroje pro formace A-20G.

Protože hmotnost Havoců neustále rostla, poslední verze vyráběné závodem v Santa Monica dostaly silnější variantu motorů R-2600-29. Kromě motorů se od A-20G a A-20J neodlišovaly. Bitevní verze s motory R-2600-29 dostala označení A-20H, bombardovací pak A-20K.

A-20G nasadilo letectvo US Army jak na evropském, tak pacifickém bojišti. V Pacifiku gunshipy A-20G zúčastnily bojů na N. Guinei, Filipínách, Palauských ostrovech, Tchaj-wanu a Okinavě. V Evropě se americké A-20 posledních verzí dostaly do bojů na Sicílii a Itálii, ale zejména byly masově nasazeny nad západní Evropou ze základen ve Velké Británii. Mimo letectvo US Army používalo Havocy verzí A-20J a K RAF. To je nasadilo pod označením Boston Mk.IV (A-20J) a Boston Mk.V (A-20K) hlavně v Itálii. S Havocy také operovala 342. peruť Svobodných Francouzů Lorraine bojující v rámci RAF. Sovětský svaz dostal Havocy A-20G jak prvních tak i pozdějších výrobních bloků a intenzivně je nasadil v rámci sovětského letectva i leteckých jednotek sovětského námořnictva. RAAF převzalo dvacet devět strojů A-20G. A-20G doplnily starší stroje Havoc/Boston u 22. sq. RAAF. Při těžkém japonském náletu 23. 11. 1944 byla část strojů zničena. Zbylé A-20G byly vráceny US Army a 22. sq. RAAF byla přezbrojena na Beaufighters. Brazílie dostala v rámci zákona Lend-Lease třicet jedna kusů A-20K, které sloužily až do poloviny padesátých let.

Technická data: rozpětí: 18,69 m, délka: 14,81m, max. rychlost: 490 km/h u země/ 510 ve výšce 3050 m, dostup: 7230 m, dolet 1610 km s 900 kg pum.

HISTORY

Ⓒ A-20G was the Havoc's first mass produced version for the USAAF. Compared to earlier versions the crew was reduced to only two members and the solid nose contained boosted armament. The early production blocks from A-20G-1 to G-15 were equipped with four 20 mm M1 cannons and two 12.7mm machine guns and early enclosed dorsal gunner's station with flexible mounted machine guns. Thanks to the weight increase and the M1 cannons jamming the USAAF was not satisfied with the early aircraft performances. 250 aircraft of the early batch were eventually given to the USSR under Lend-Lease. The rest of the already produced aircraft armament changed from cannon to machine guns. From A-20G-20 the aircraft were delivered with six nose mounted 12.7 mm machine guns and electrically driven Martin turret with two 12.7 mm machine guns mounted into widened dorsal position. The subsequent production blocks were the same.

Bomber version A-20J intended for European Theatre was based on A-20G. This version received the glazed nose section for navigator-bombardier. These aircraft were also used as A-20G formation leaders.

Since the Havocs' weight increased constantly the last produced versions in Santa Monica received more powerful R-2600-29 engines. Engines were the only difference from A-20G. The ground attack version with R-2600-29 engines was designated A-20H and bomber version A-20K.

USAAF deployed A-20Gs to both European and Pacific theaters. Gunships A-20G in Pacific participated in fights over New Guinea, Philippines, Palau Islands, Thai-Wan and Okinawa. In Europe, the late versions of US Havocs participated in fights over Sicily and Italy but were mainly deployed over Western Europe from their bases in Great Britain. Except USAAF were A-20J and K Havocs used by RAF that deployed them under its own designation Boston Mk.IV (A-20J) and Boston Mk.V (A-20K) mainly over Italy. Havocs were also operated by Free French 342nd Squadron Lorraine under RAF. USSR received A-20Gs of early as so the later production blocks and assigned them to both air force units and navy units. RAAF received twenty nine A-20Gs. The Gs completed the early version of Havocs / Bostons in RAAF 22 Squadron. Several machines were destroyed during heavy Japanese air raid on November 23, 1944. The remaining A-20Gs were returned to USAAF and RAAF 22 Squadron was re-equipped with Beaufighters. Under Lend-Lease, 31 A-20K were delivered to Brazil where served up to the 1950s.

Technical Data: Wing span: 18.69m, Length: 14.81m, Max. Speed: 490kmh at sea level / 510kmh at 3050m, Service Ceiling: 7230m, Range: 1610km with 900kg bomb load

KIT PARTS

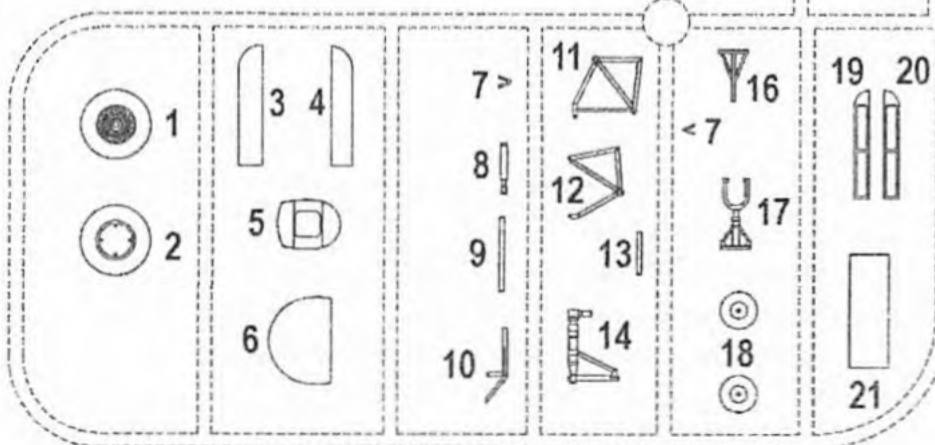
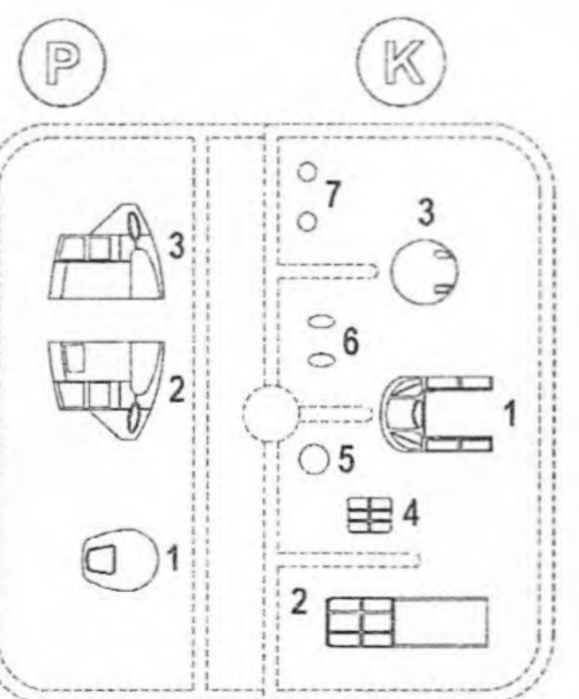
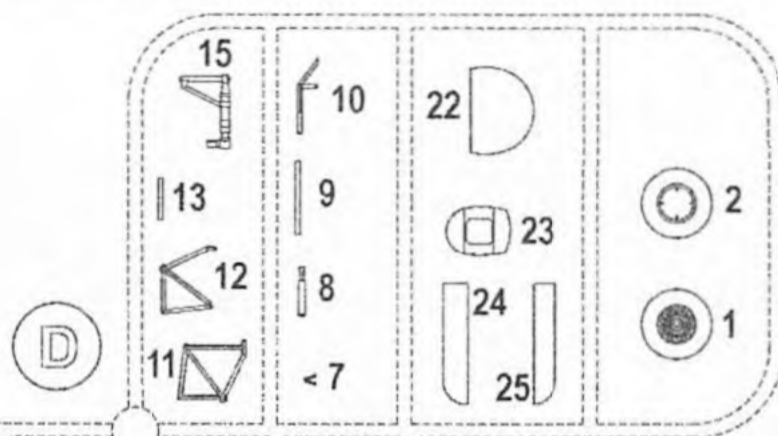
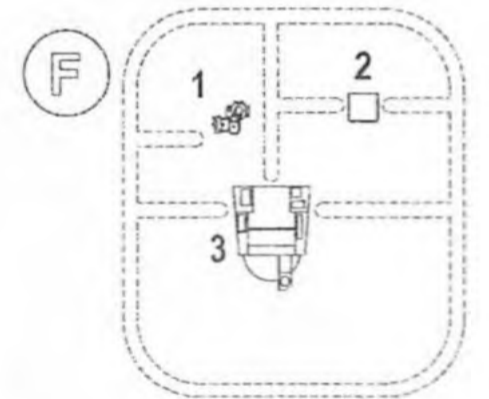
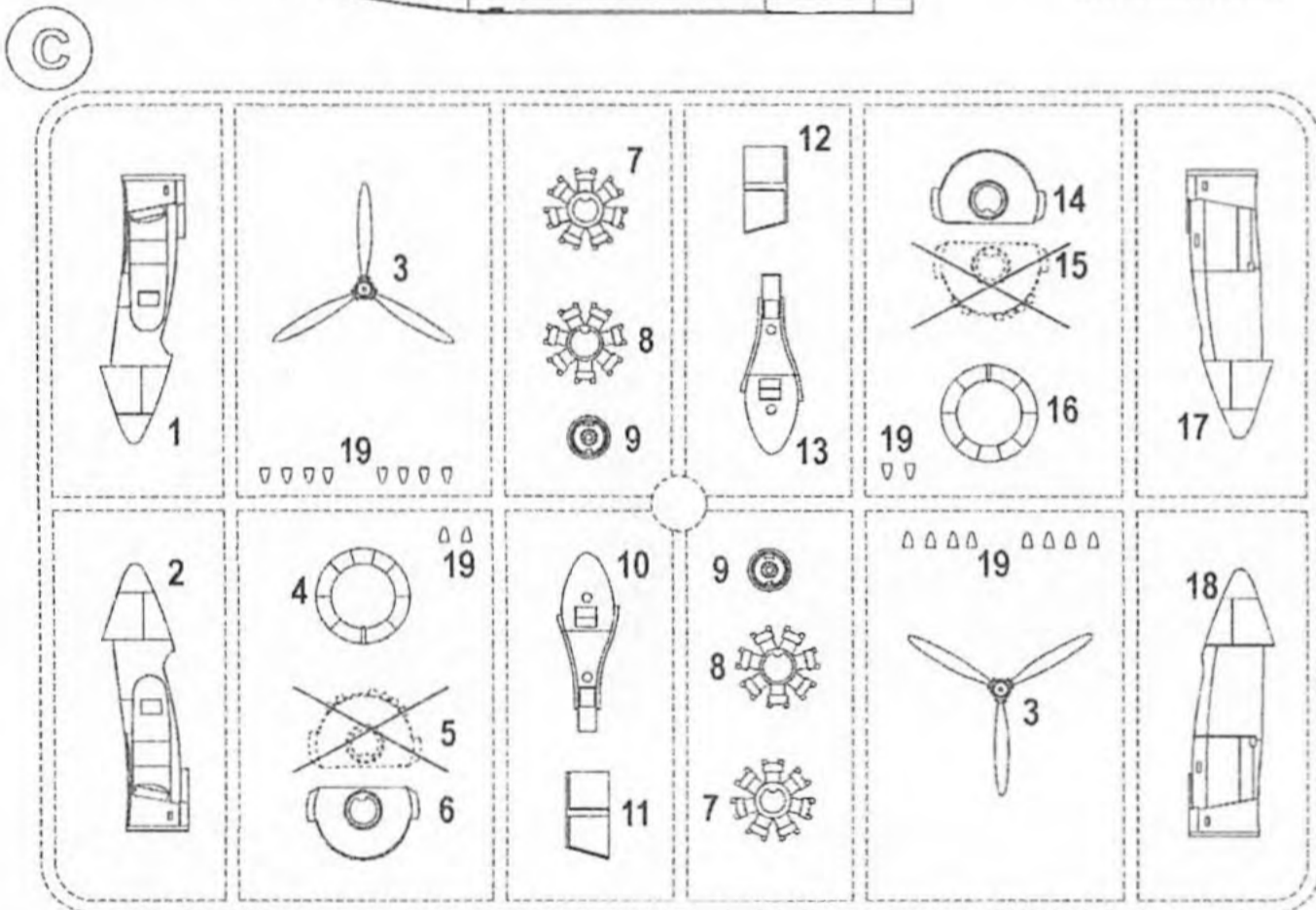
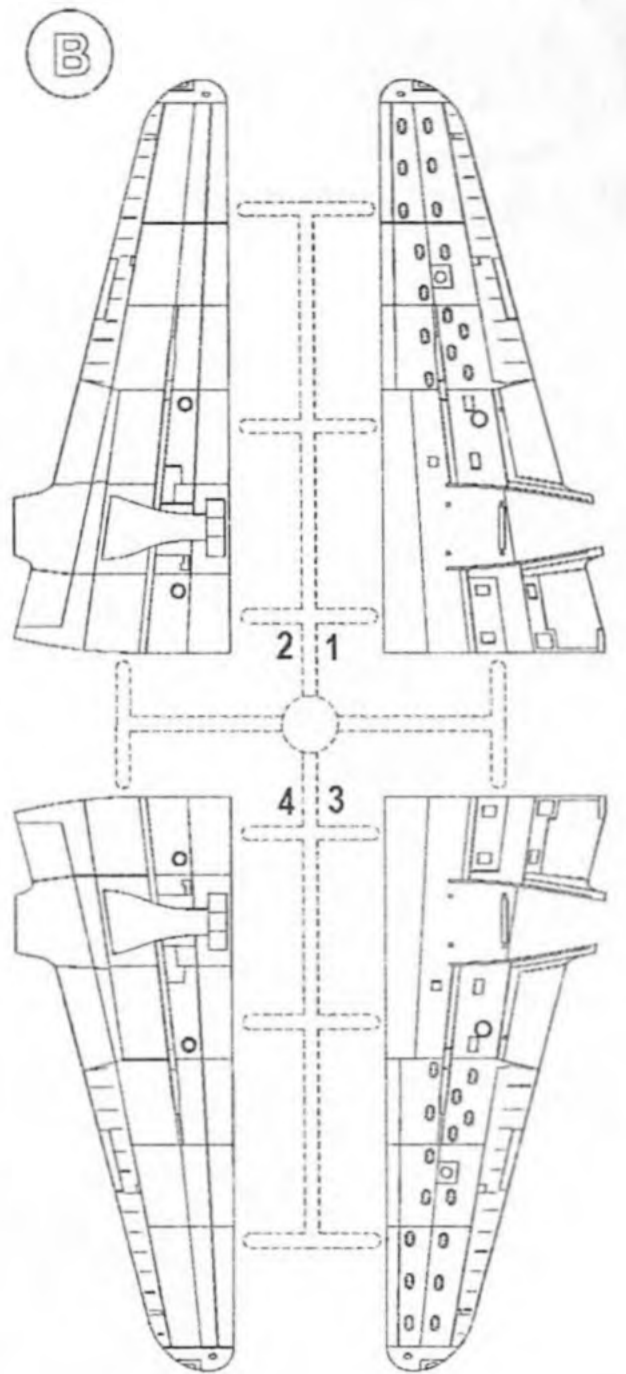
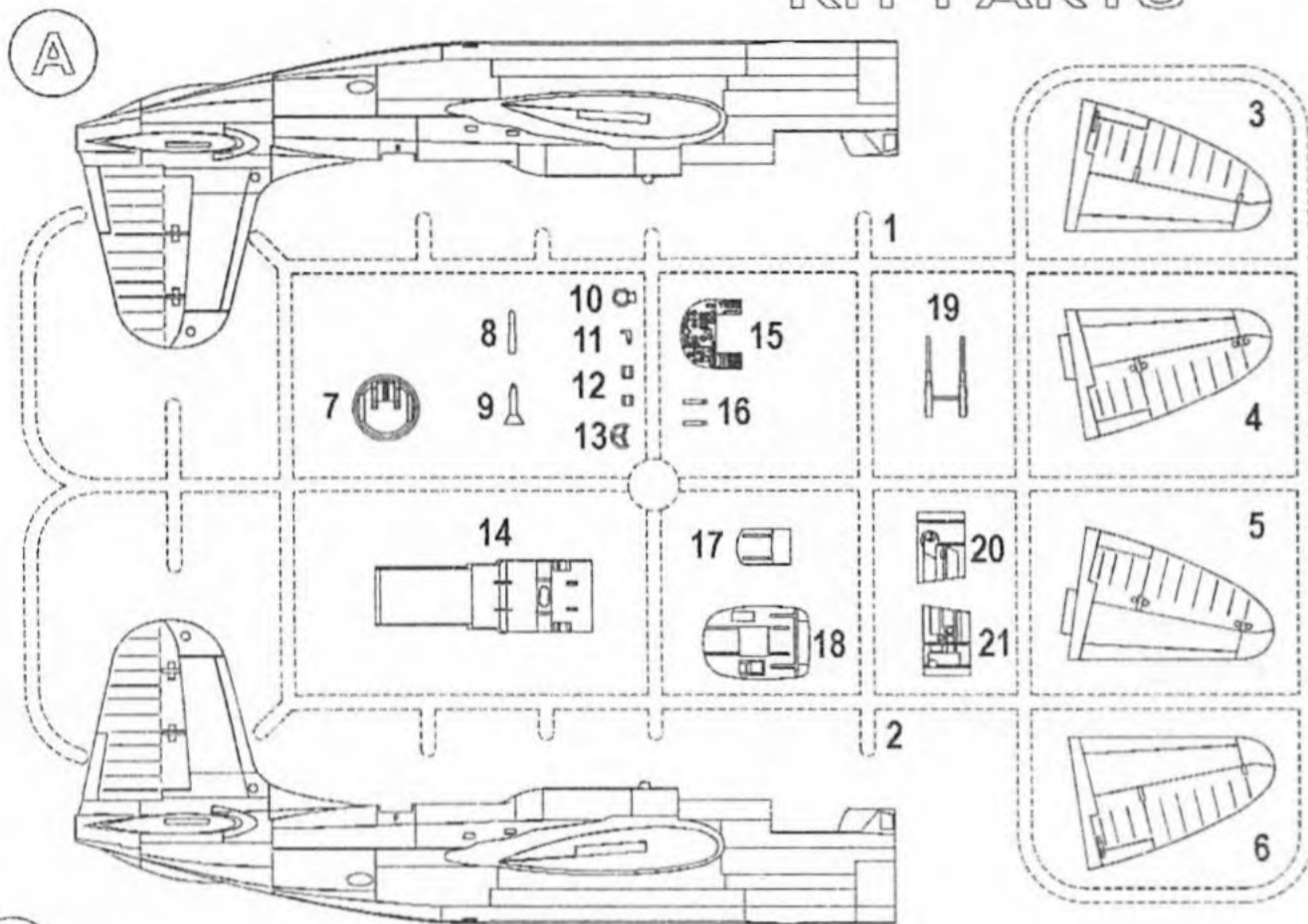

SYMBOLS

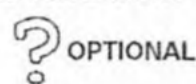

WEIGHT



CUT OFF



SCRATCH BUILD

ASSEMBLY

STEP
1

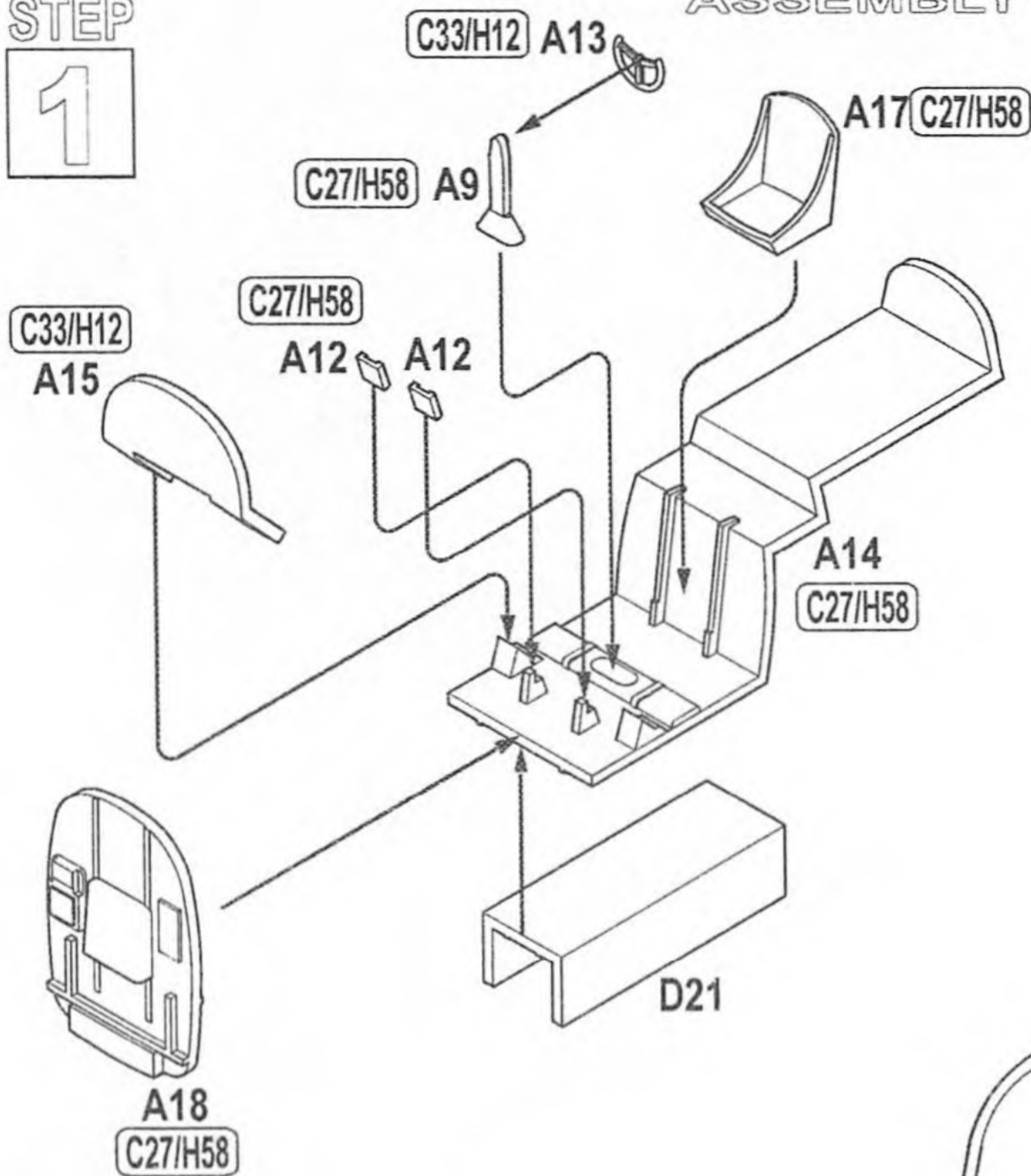

STEP
2

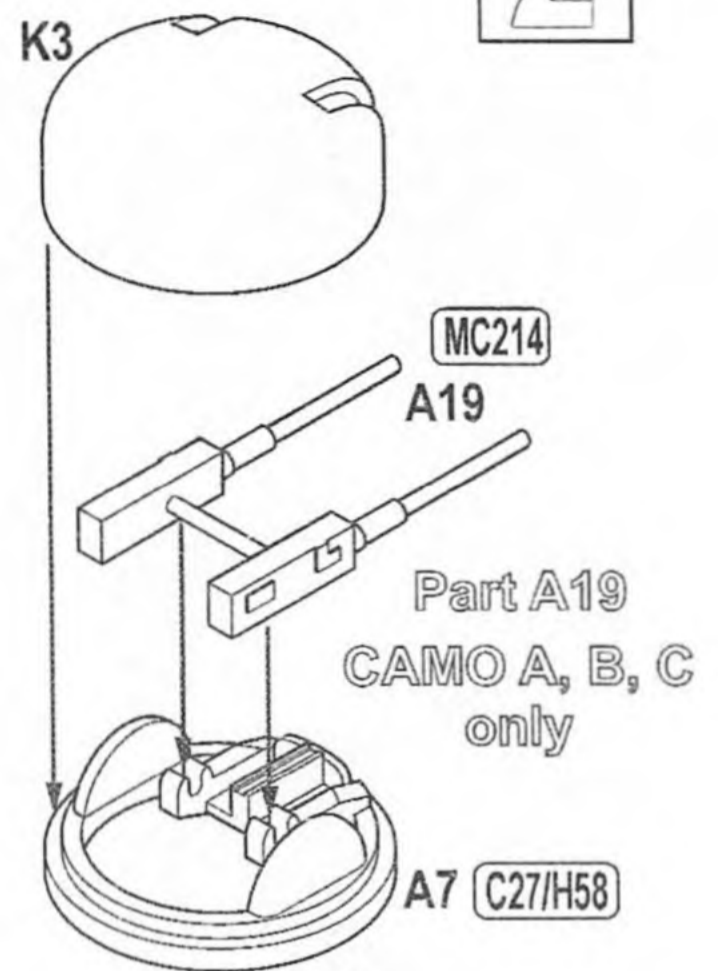

Díly A20 a A21 pečlivě začistěte a vlepte tak, aby přesně zapadly do vybrání v polovinách trupu. Na dílu A21 odřízněte roh dle obrázku.
Carefully clean parts A20 and A21 so they fit in recesses in the fuselage halves. Cut the corner of part A21 according to the drawing.

STEP
3

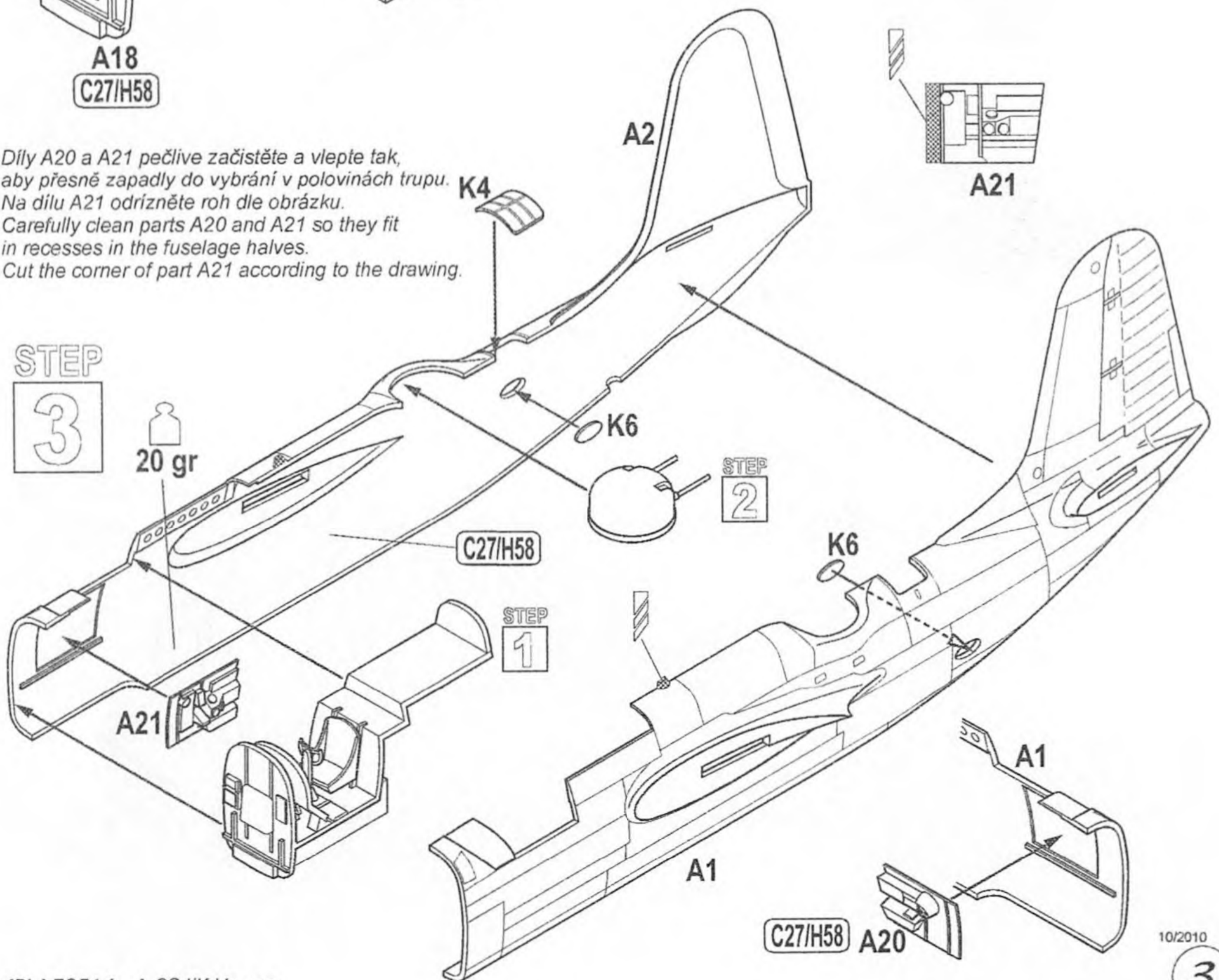

ASSEMBLY

STEP
5

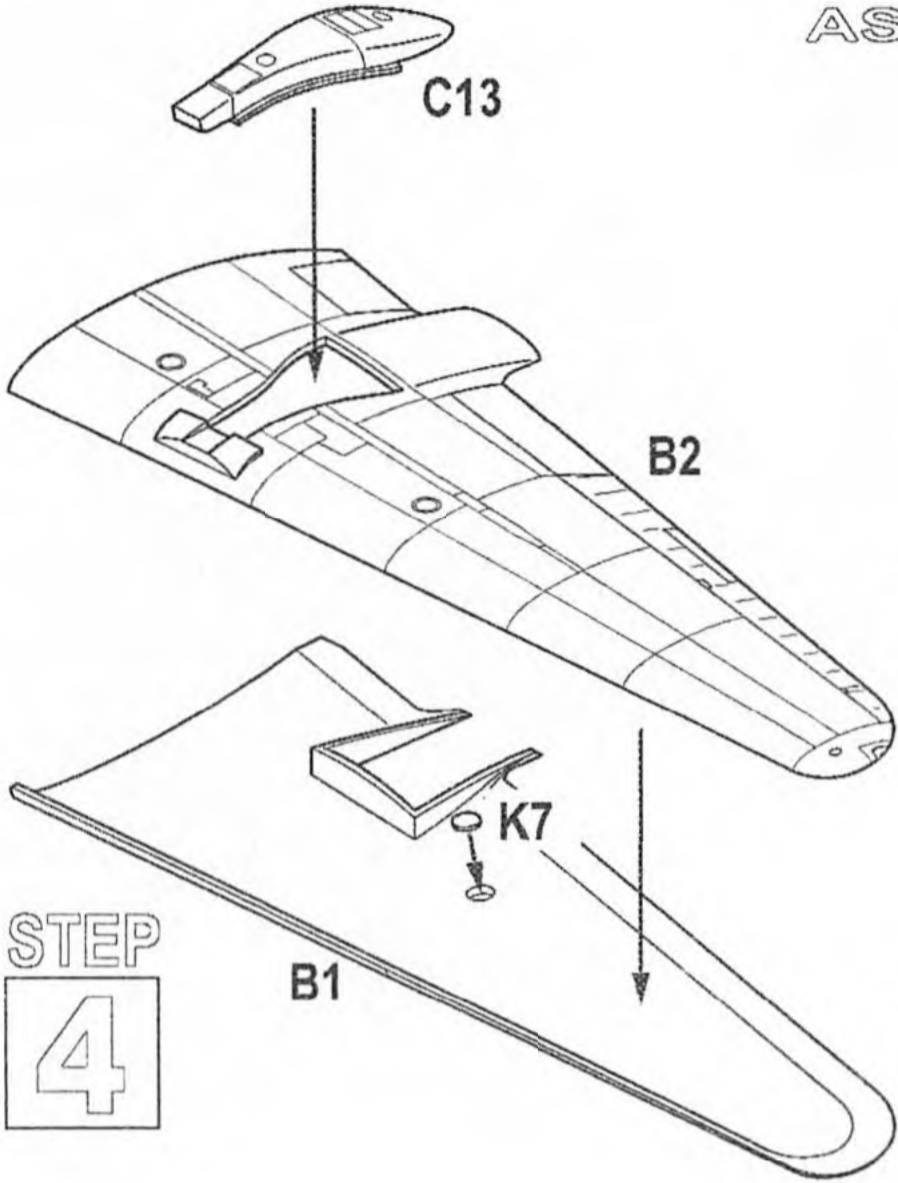

STEP
4

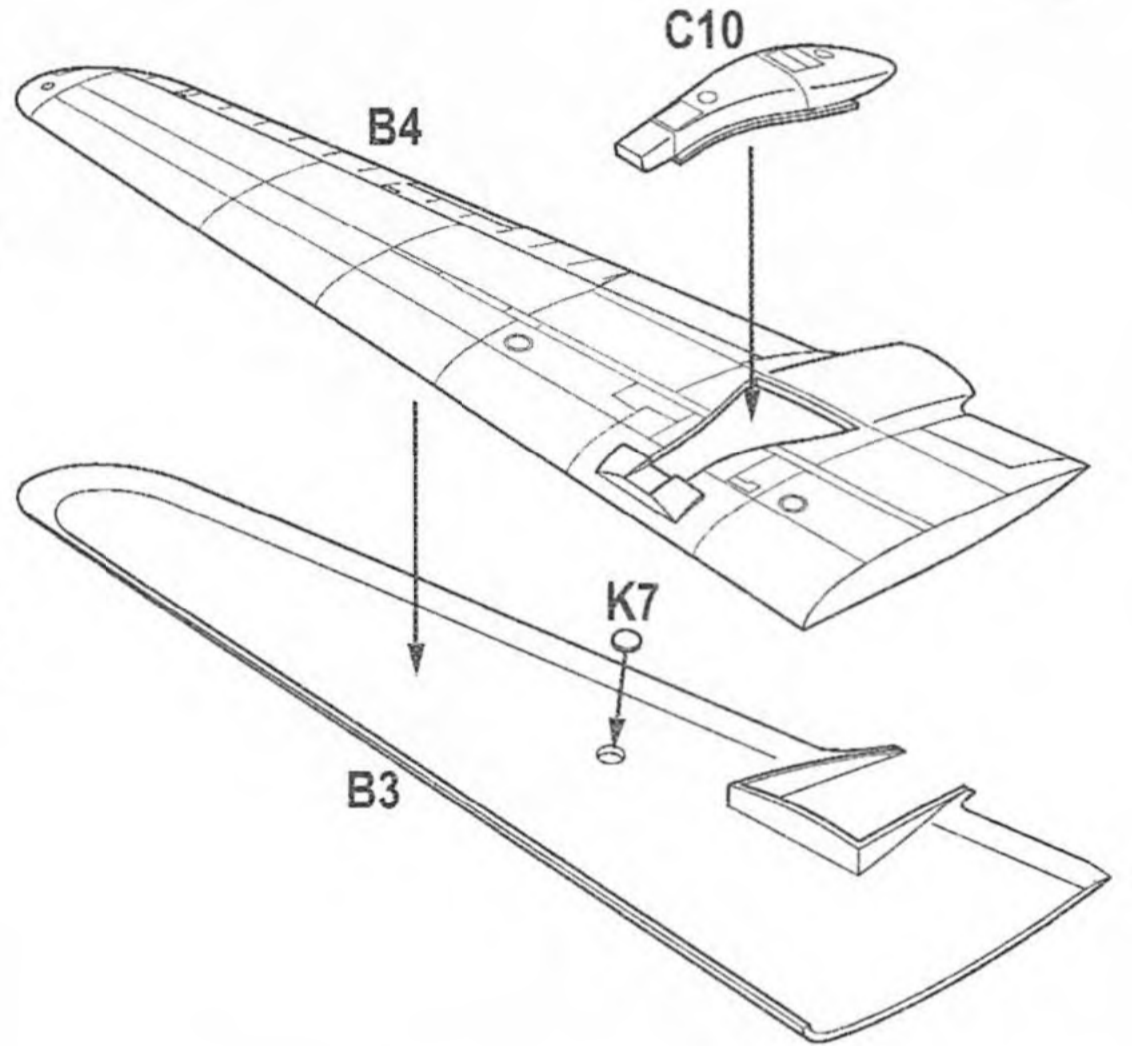

STEP
6

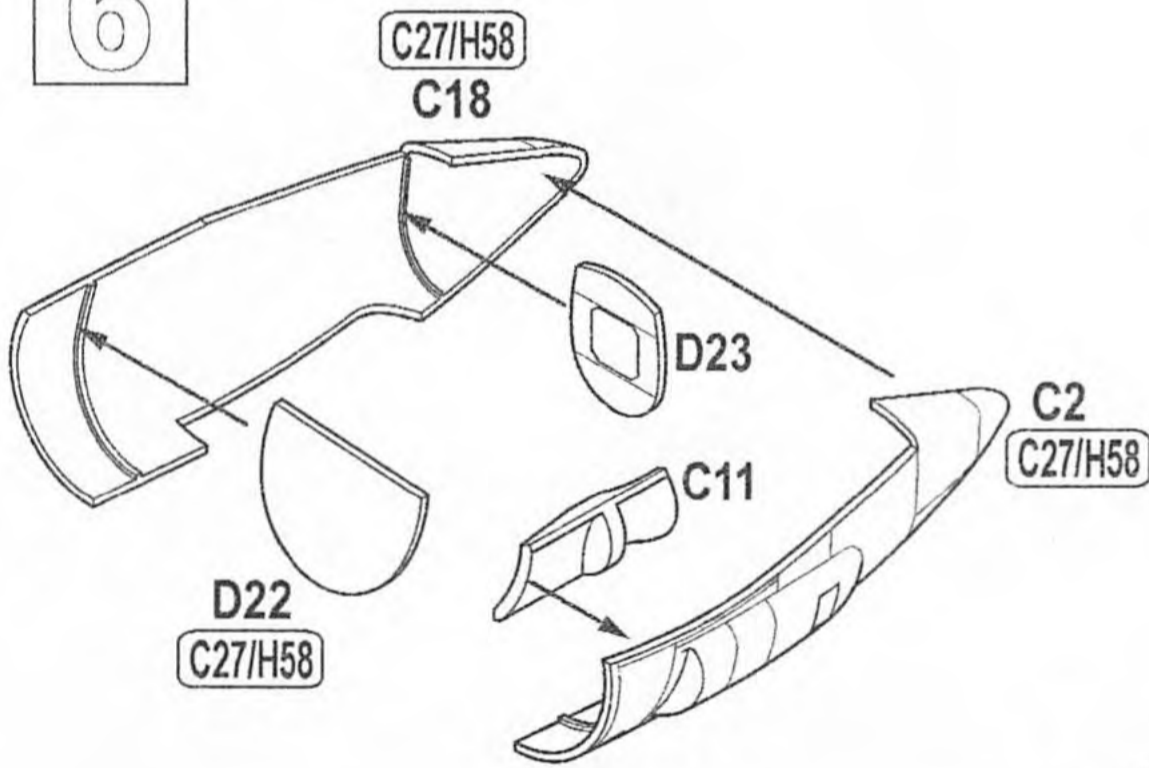

STEP
7

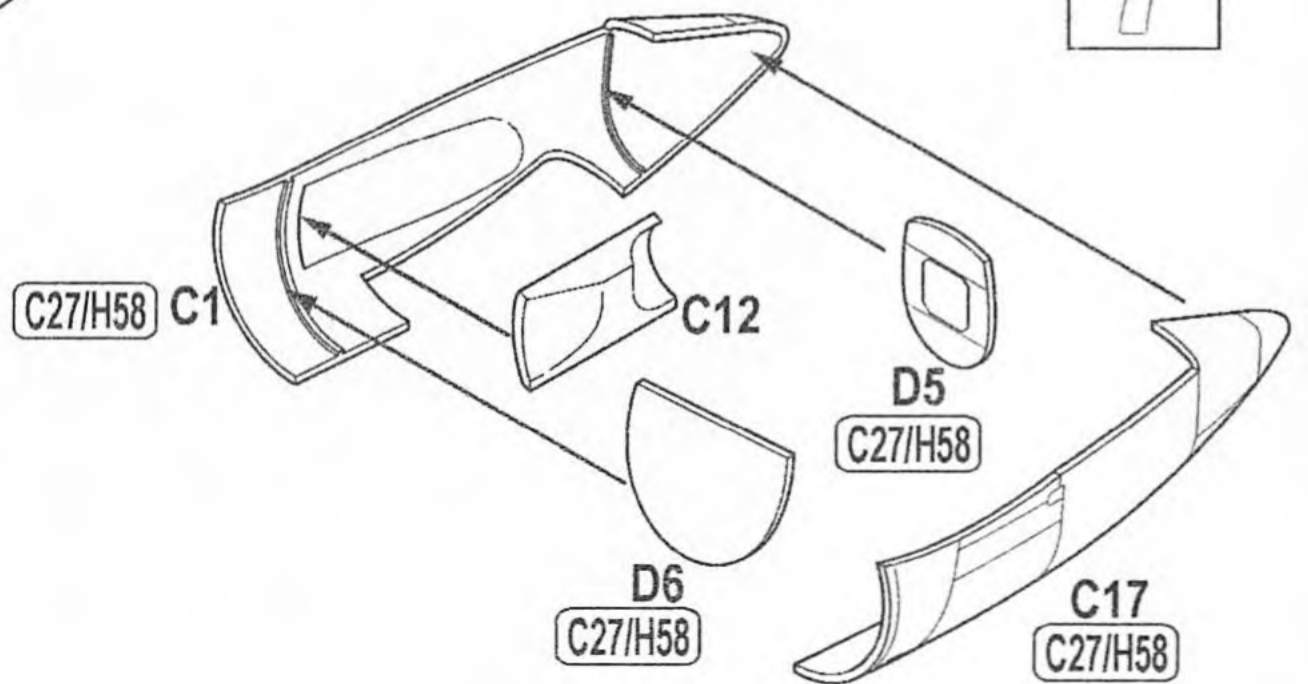

ASSEMBLY

STEP
8L

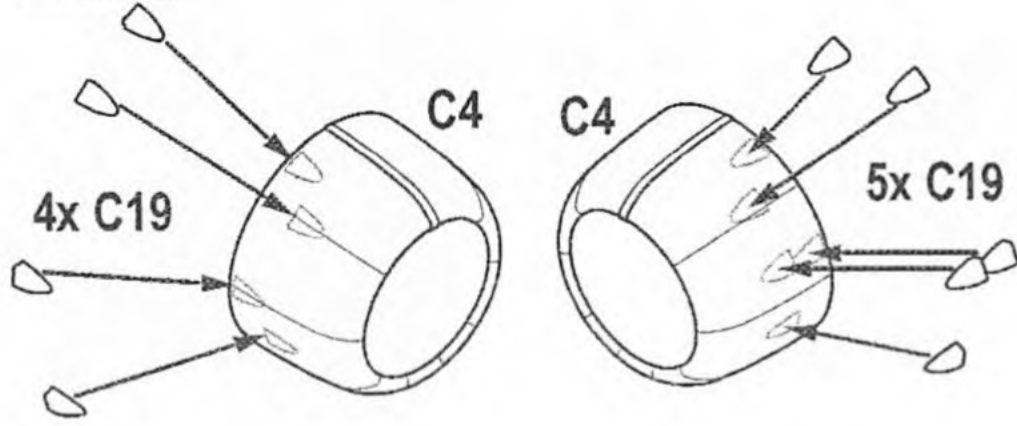

STEP
8R

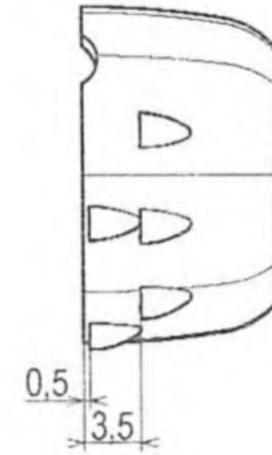
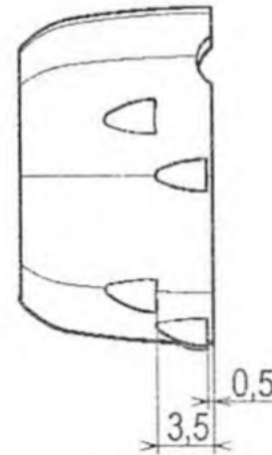
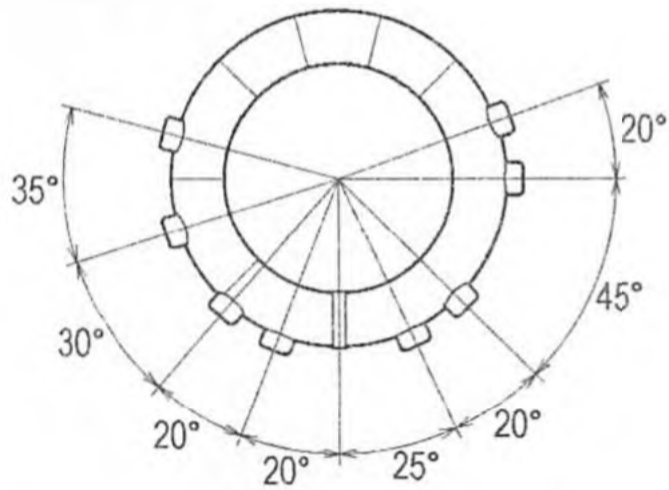
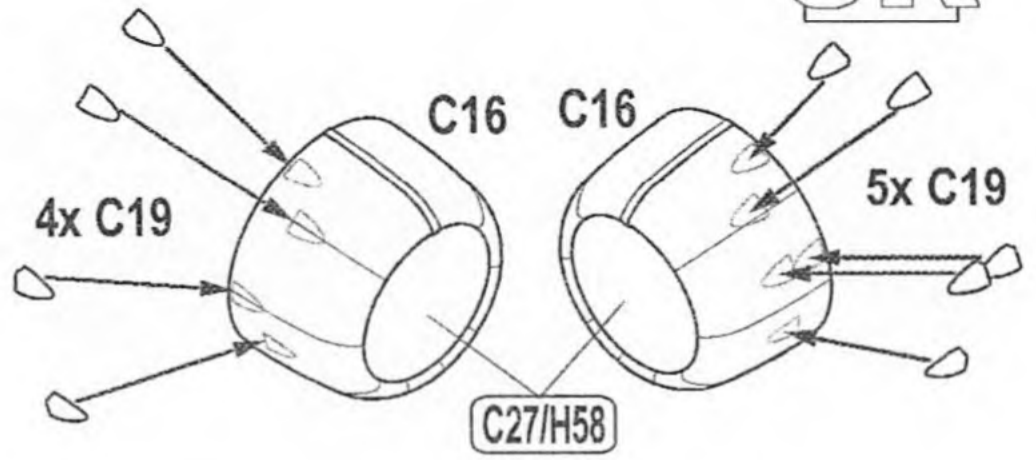

STEP
9

? CAMO A, B, D

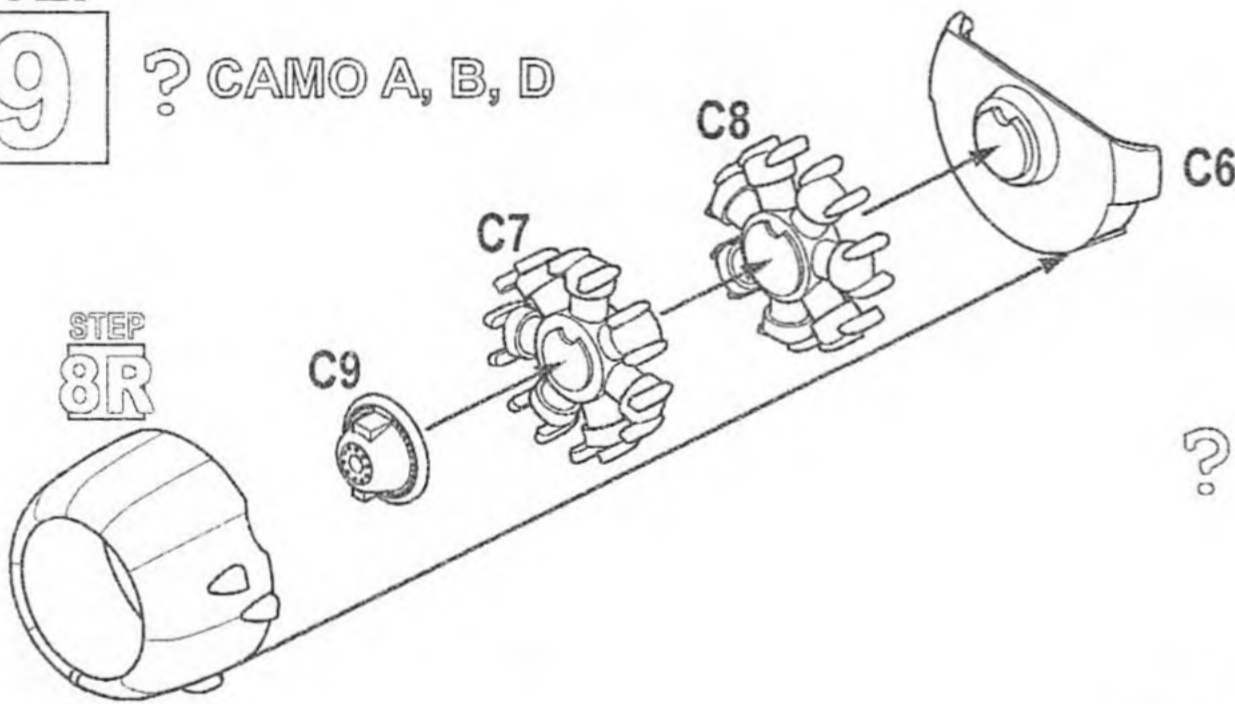

STEP
8R

? CAMO A, B, D

STEP
10

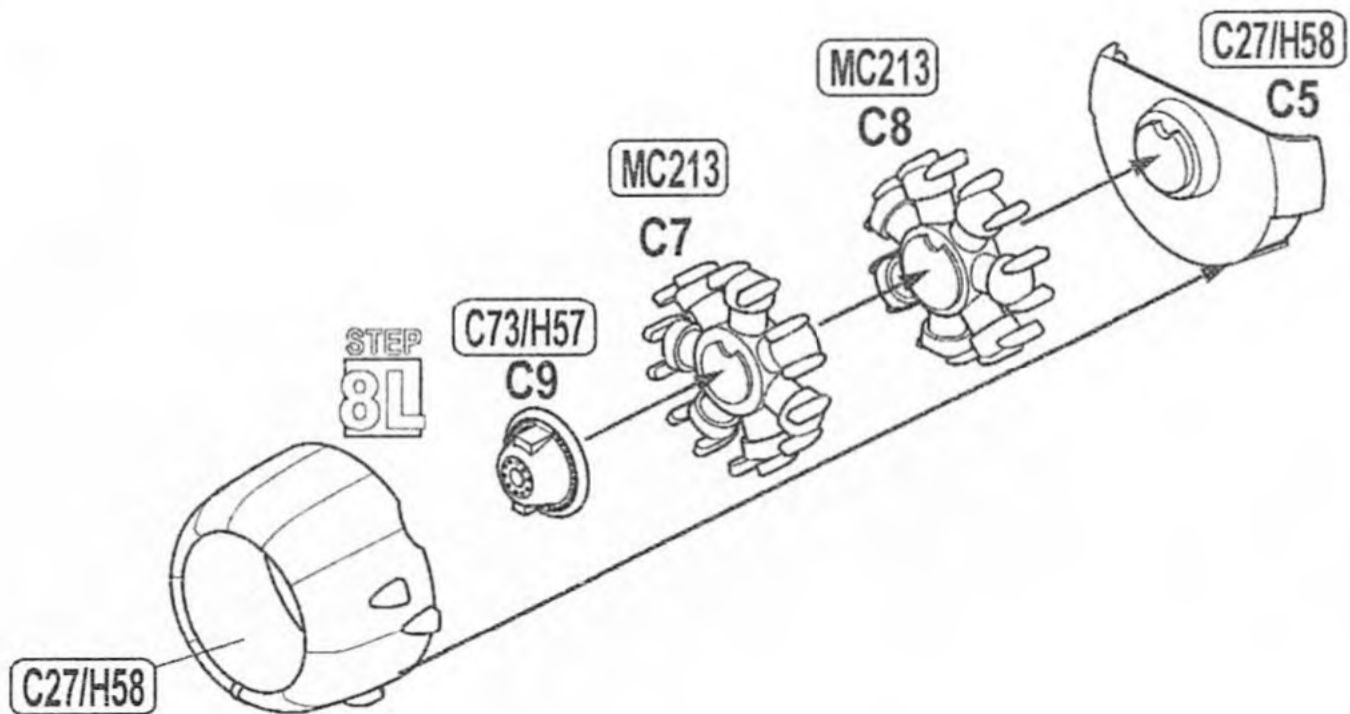

STEP
11

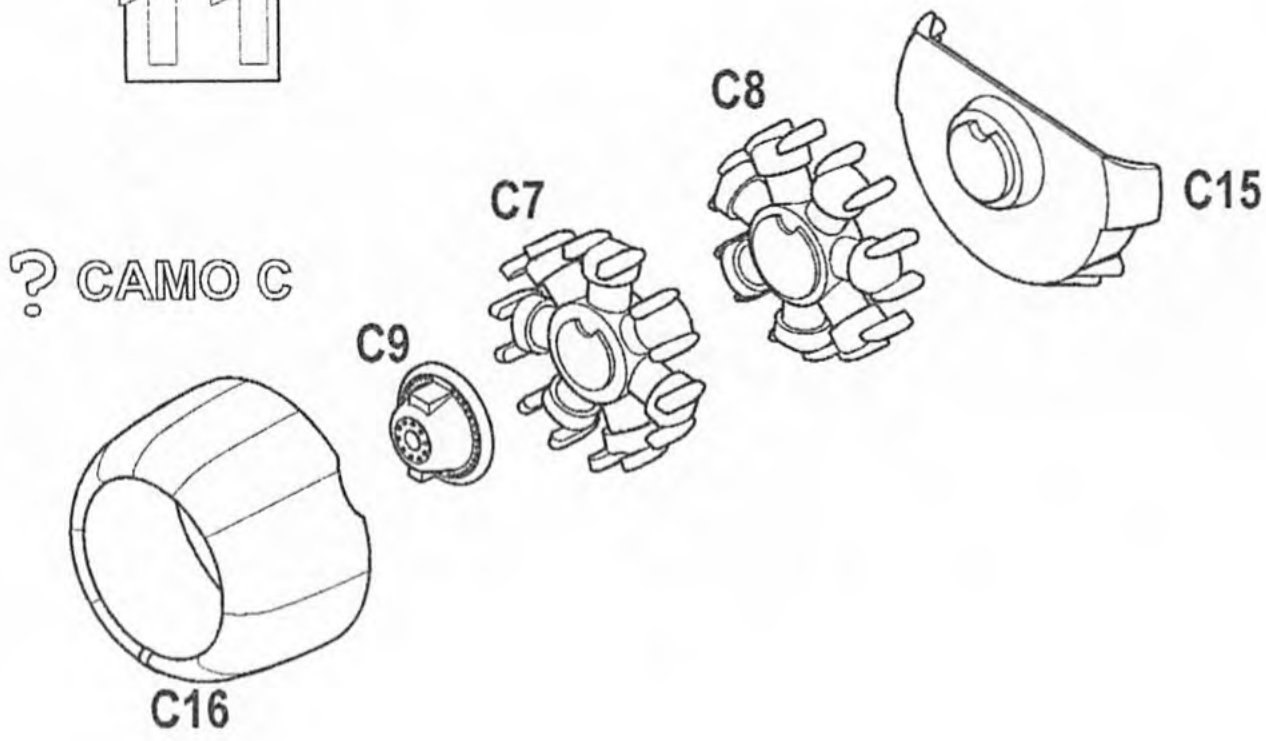

STEP
12

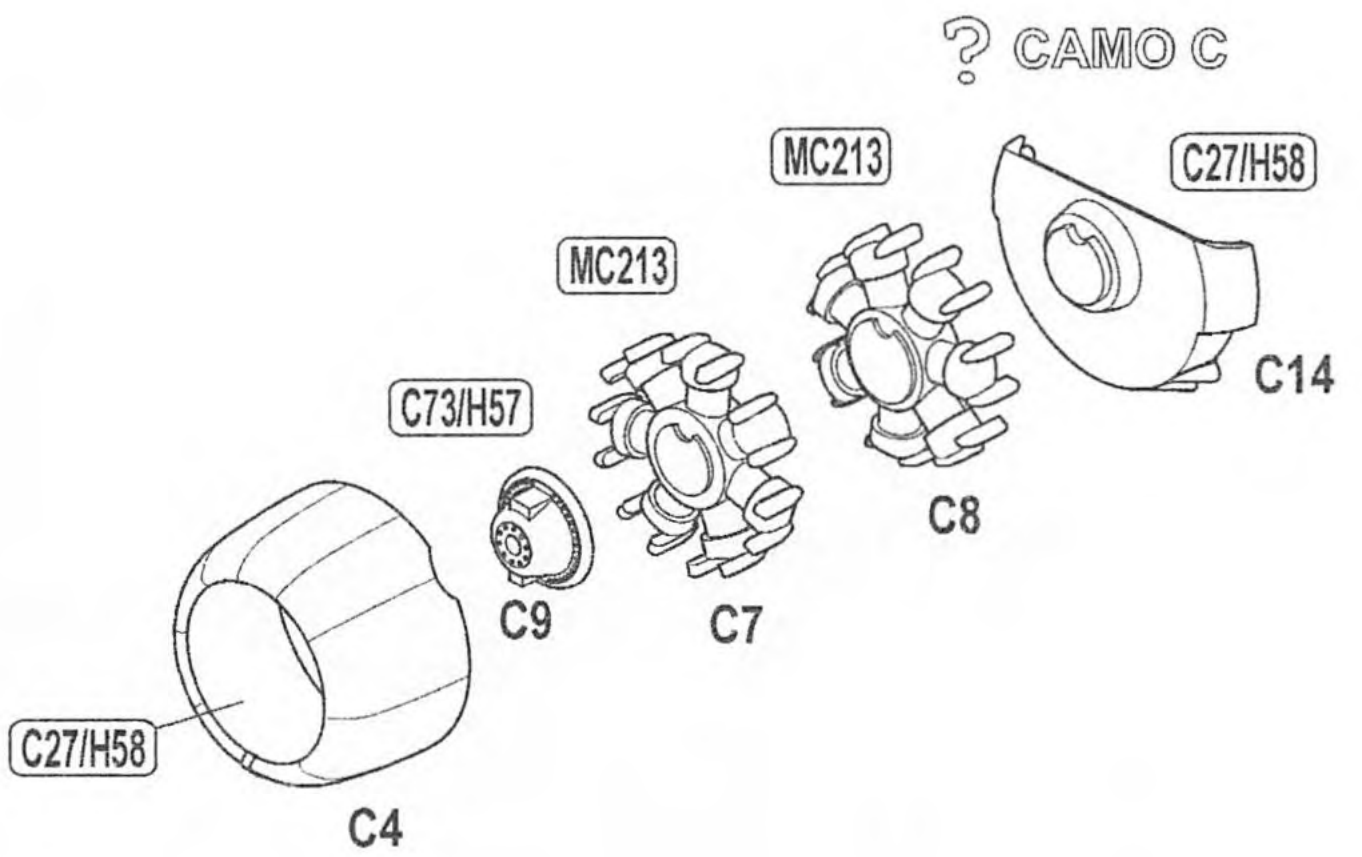

STEP
13

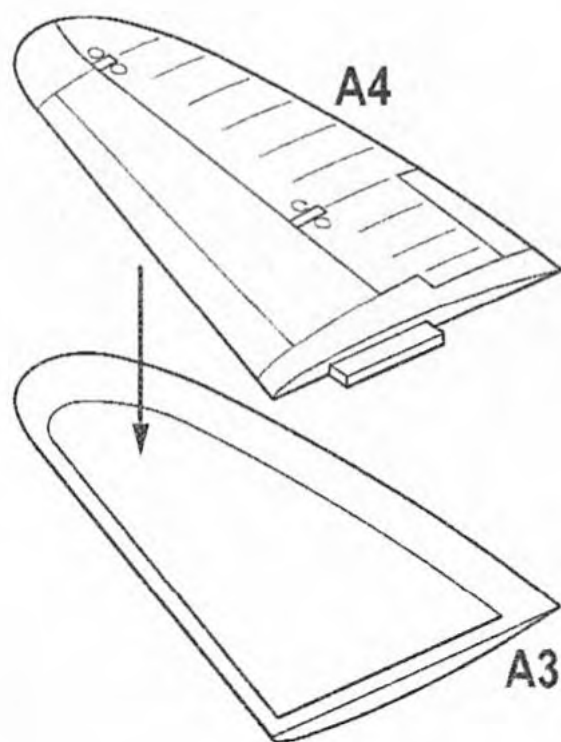

STEP
14

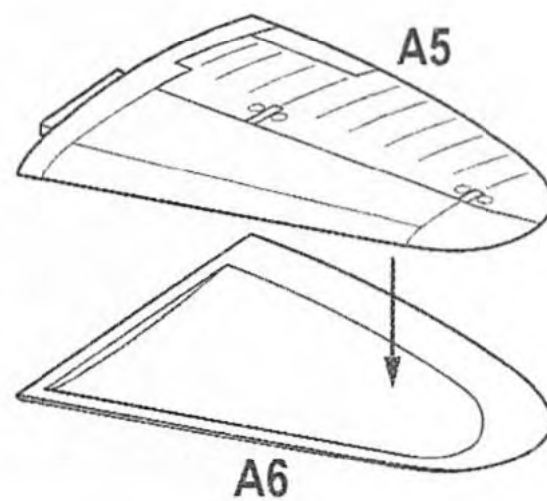

STEP 15

ASSEMBLY

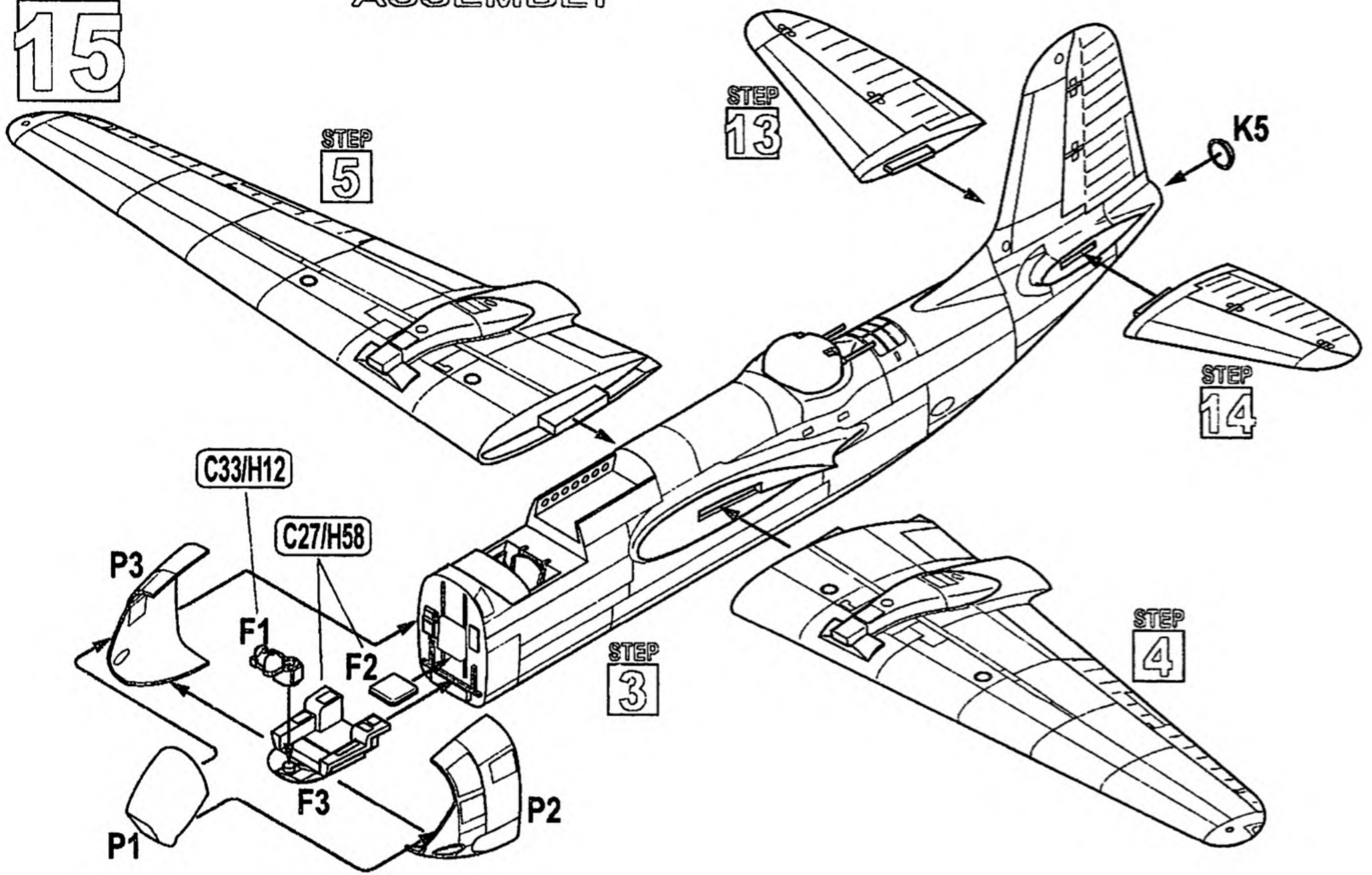

STEP 16

C27/H58

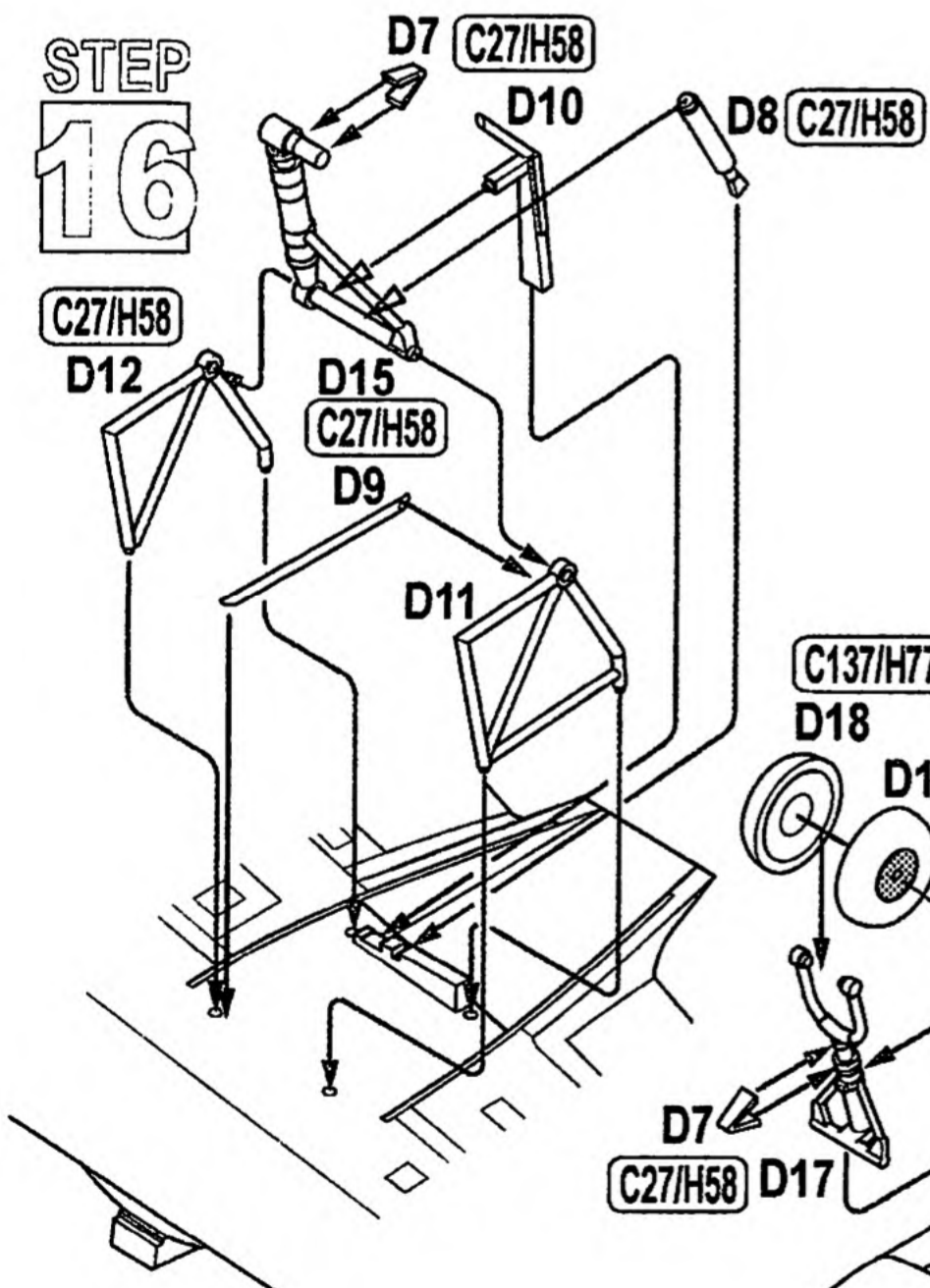

STEP 17

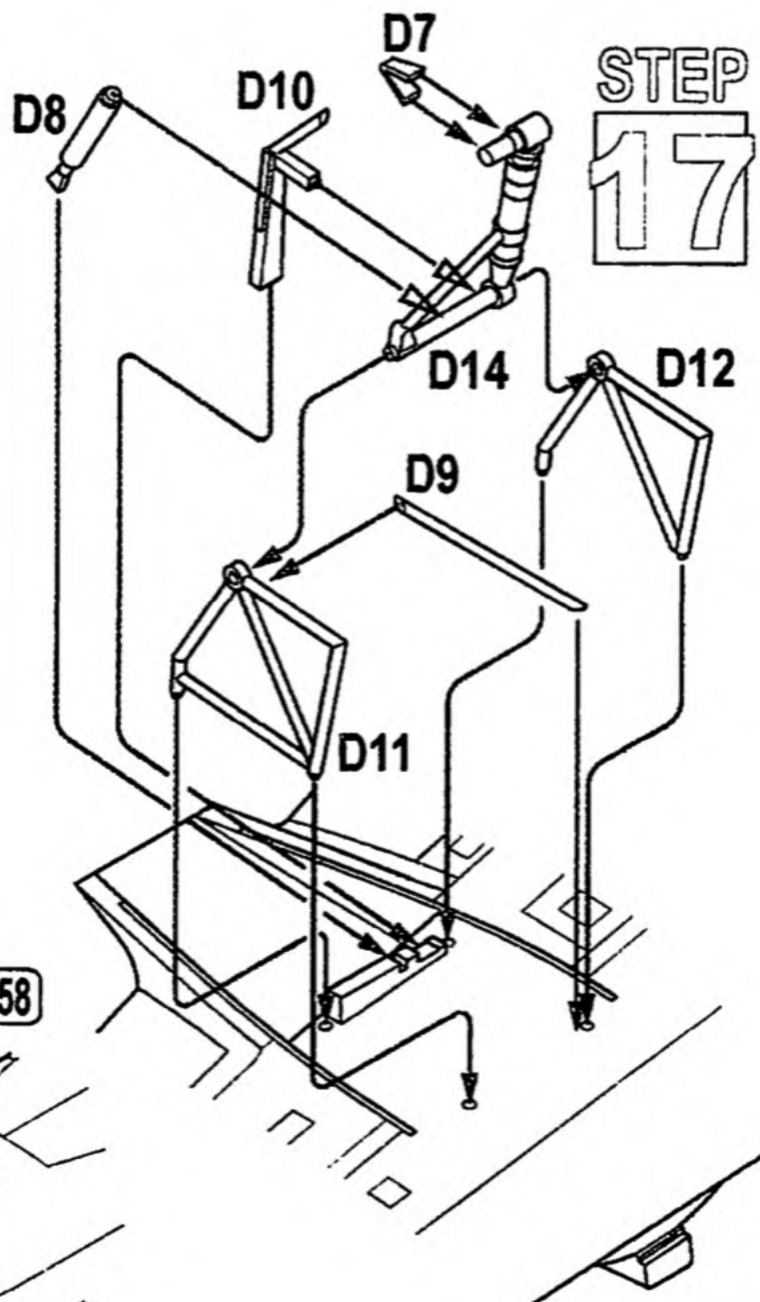

STEP 18

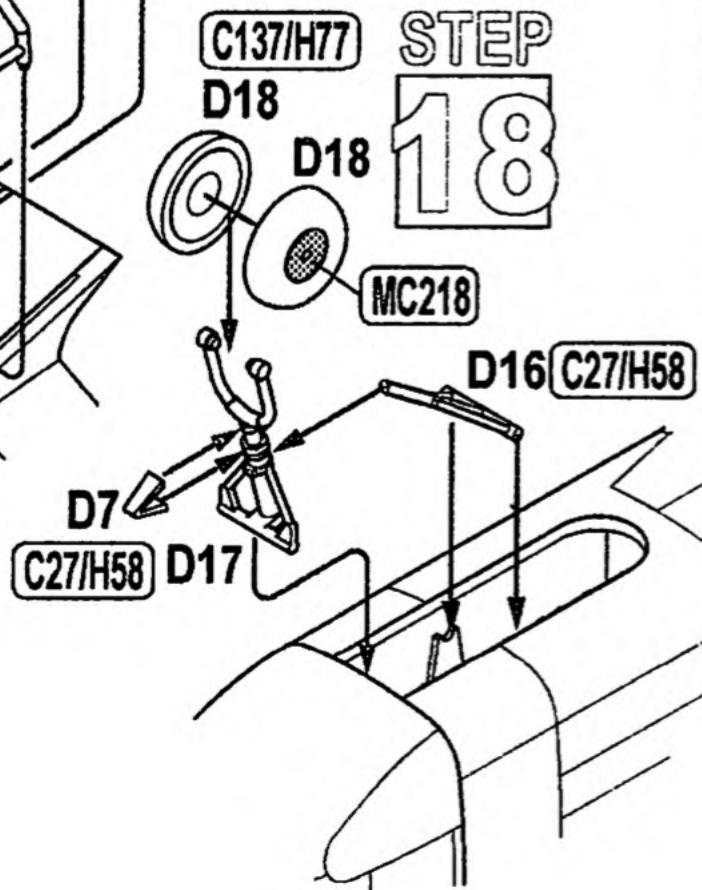

STEP 19

ASSEMBLY

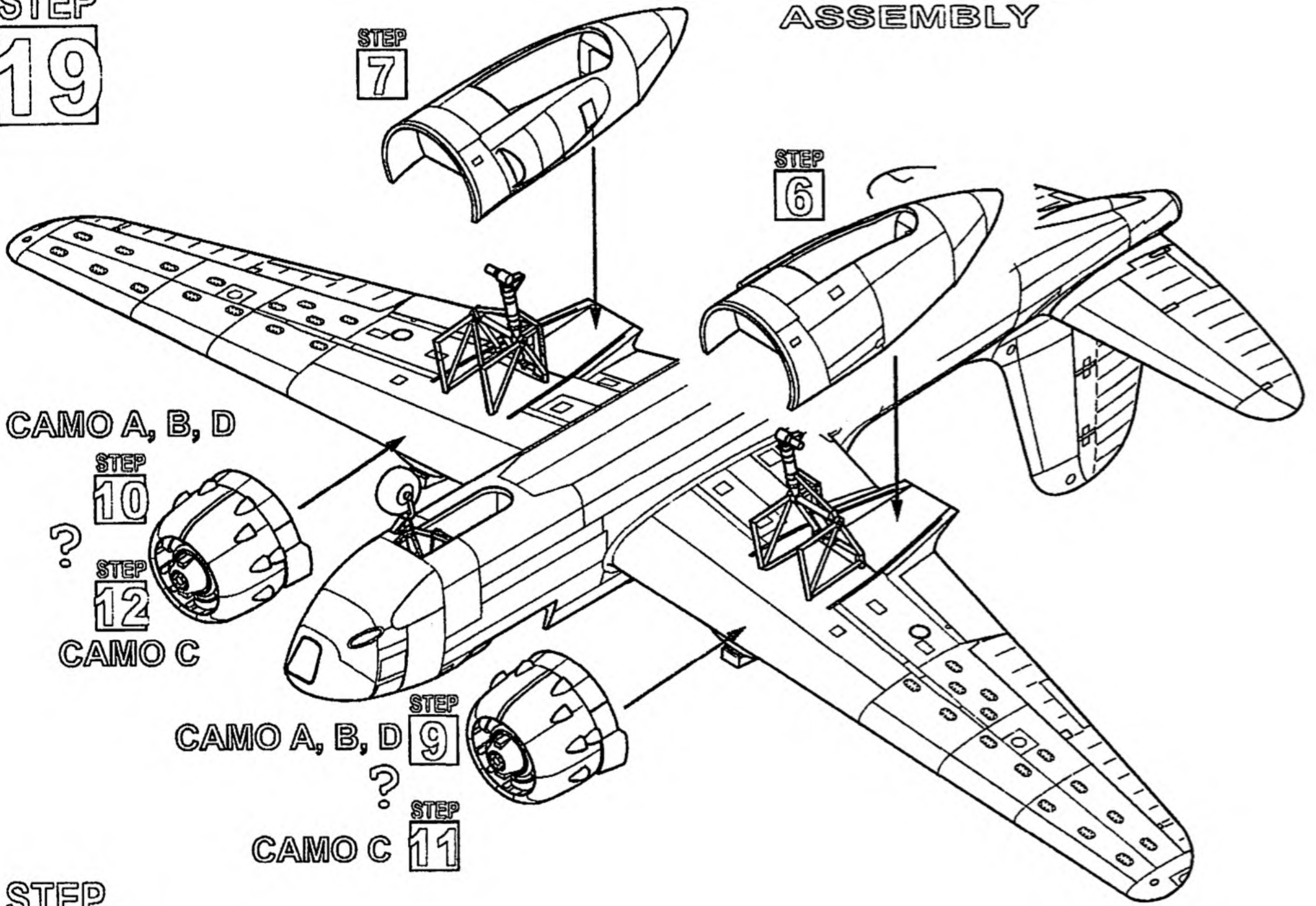

STEP 20

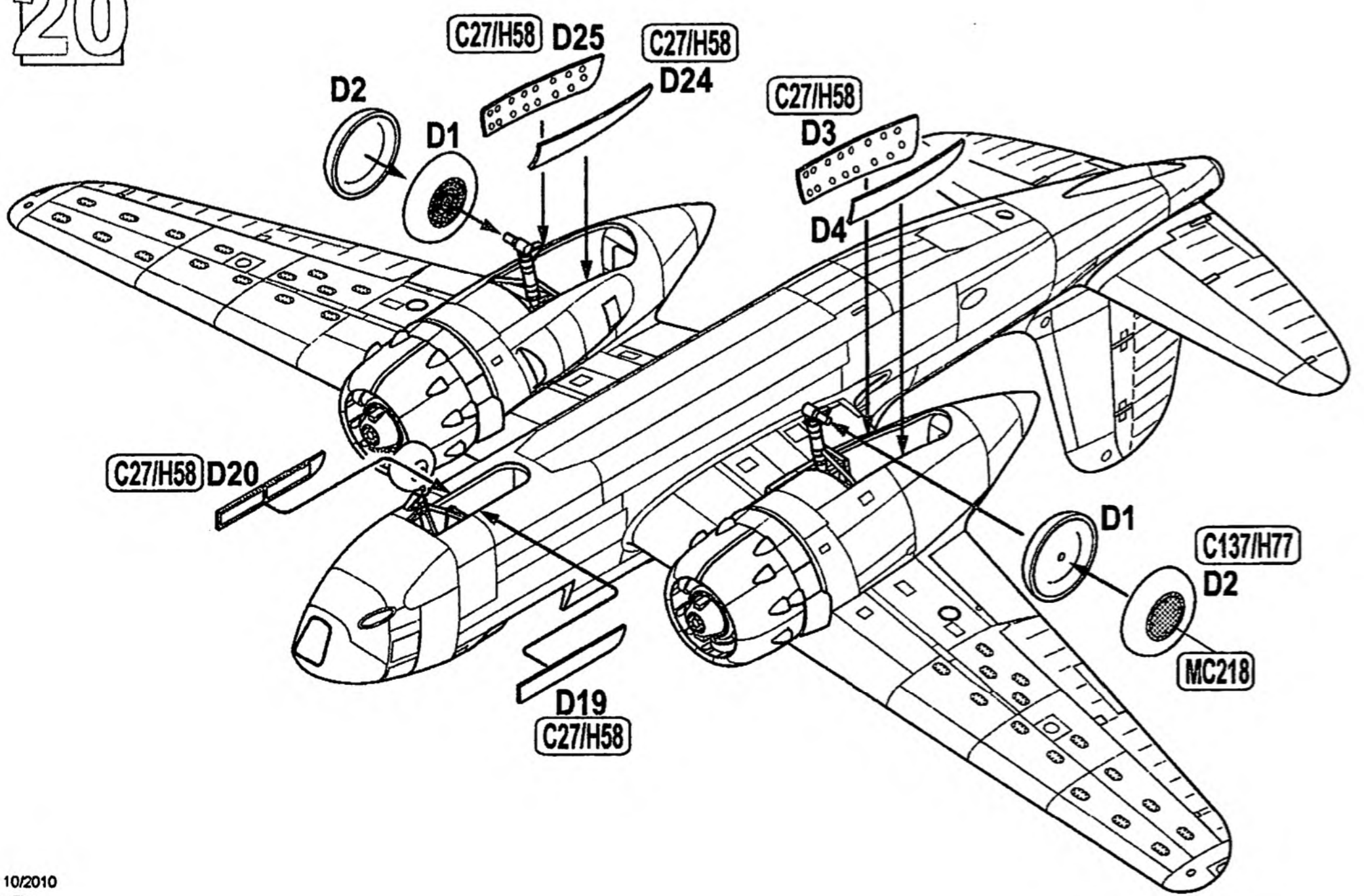

10/2010

STEP
21

ASSEMBLY

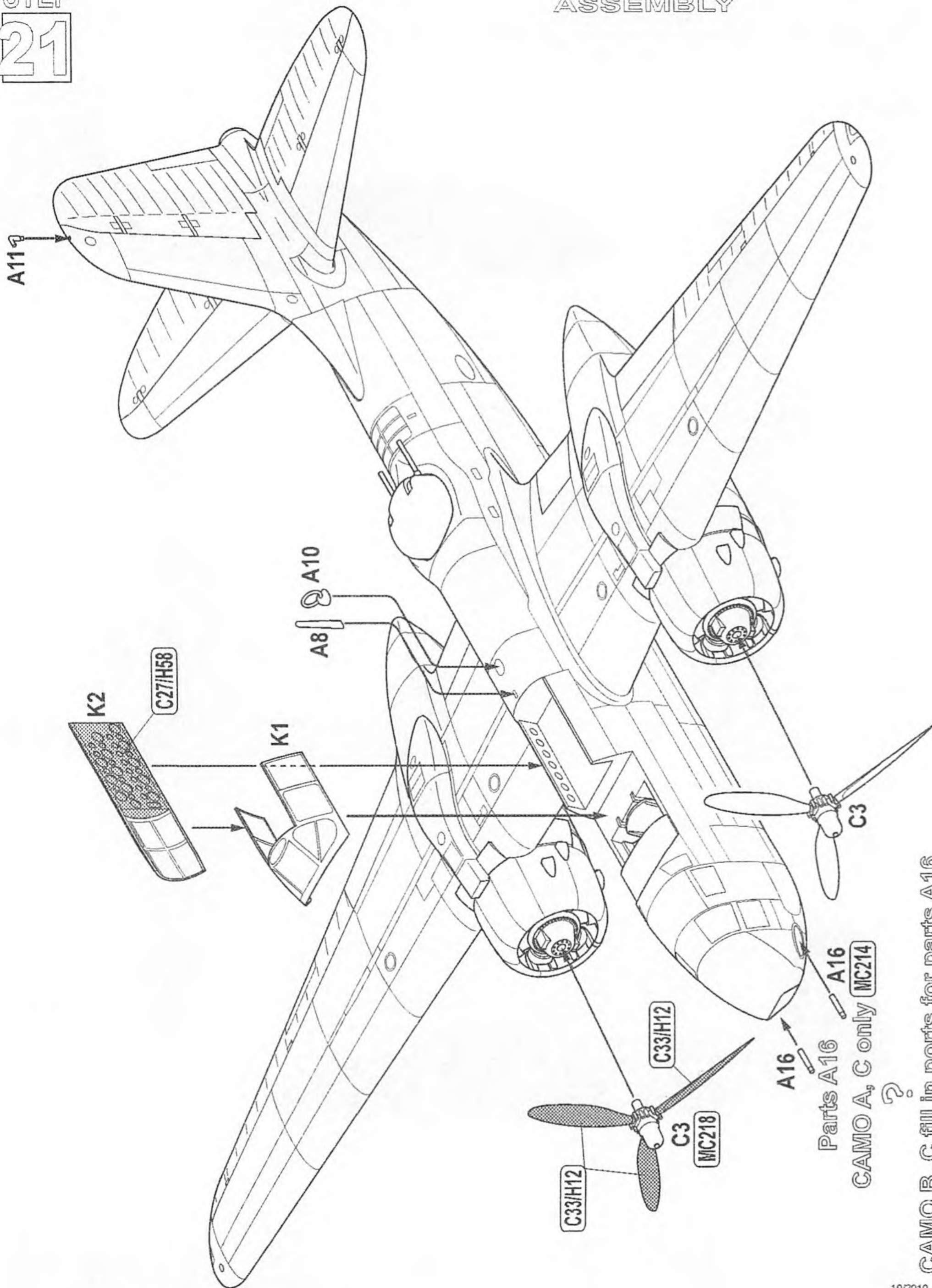

Parts A16
CAMO A, C only MC214
?
CAMO B, C fill in ports for parts A16

A-20K, 43-4613/ 7X-T, "Helen", 645. bombardovací squadrona, 410. bombardovací skupina, základna Coulommiers, Francie. počátek roku 1945. Tento stroj byl celý kamuflován lesklou černou barvou Jet Black (ANA 622) pro noční operace. Kormidlo bylo pravděpodobně při opravě použito z jiného stroje a je kamuflováno barvami Olive Drab a Medium Green. Trupové znaky byly patrně přestříkány lehce šedou, aby se snížila jejich viditelnost.

A-20K, 43-4613, "Helen", 645 BS, 410 BG, Coulommiers airbase, France, early 1945. This machine was painted overall in Jet Black (ANA 622) for night operations. The rudder seems to be replacement from another aircraft originally painted in Olive Drab and Medium Green. The fuselage national insignias were most likely toned down by Light Grey over spraying.

CAM. A

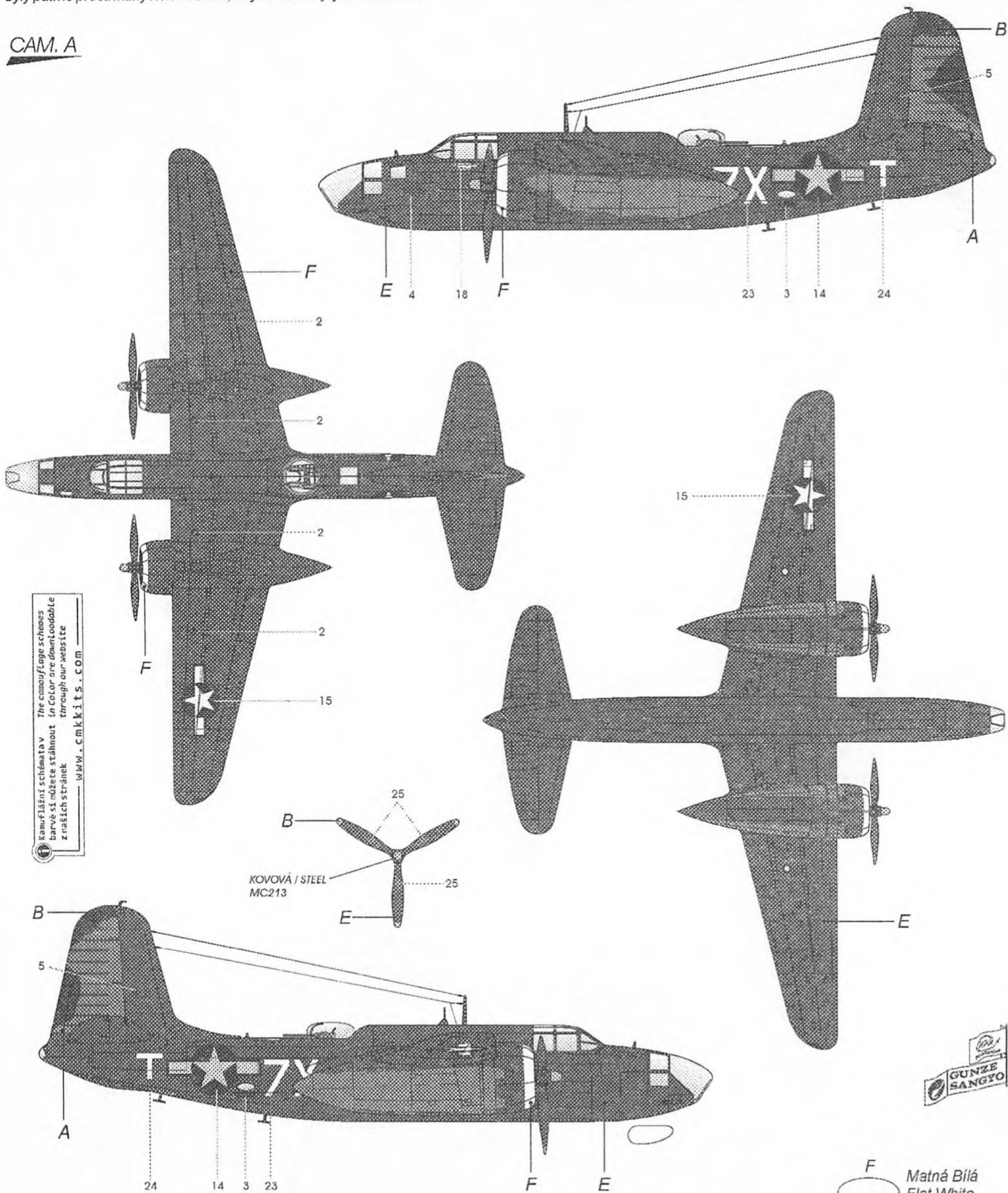

Kamuflažní schémata v barvě si můžete stáhnout z našich stránek www.cmkkits.com

- | | | | | | |
|--|---|---|--|--|---|
|  <p>A Olivová 41
Olive Drab 41
H52 / C12</p> |  <p>B Střední zelená 42
Medium Green 42
H302 / C302</p> |  <p>C Světle šedá 43
Neutral Grey 43
H53 / C13</p> |  <p>D Žlutá
Yellow
H329 / C329</p> |  <p>E Matná Černá
Flat Black
H12 / C33</p> |  <p>F Matná Bílá
Flat White
H11 / C62</p> |
|--|---|---|--|--|---|

A-20J, 43-9913/8U-A, "Maxine", 646. bombardovací squadrona, 410. bombardovací skupina, květen 1944. Tento stroj patřil veliteli squadrony a byl ozdoben modrými doplňky na motorových krytech a vrtulových nábojích. Obrazec nad jménem "Maxine" představuje stát Texas. Tento stroj byl později ztracen při bojové akci.

A-20J, 43-9913/8U-A, "Maxine", 646 BS, 410 BG, May 1944. The squadron commander's machine sported blue squadron colour front parts of the engine cowlings and propeller hubs. The shape above the name "Maxine" represents State of Texas. This machine was later lost during mission.

CAM. B

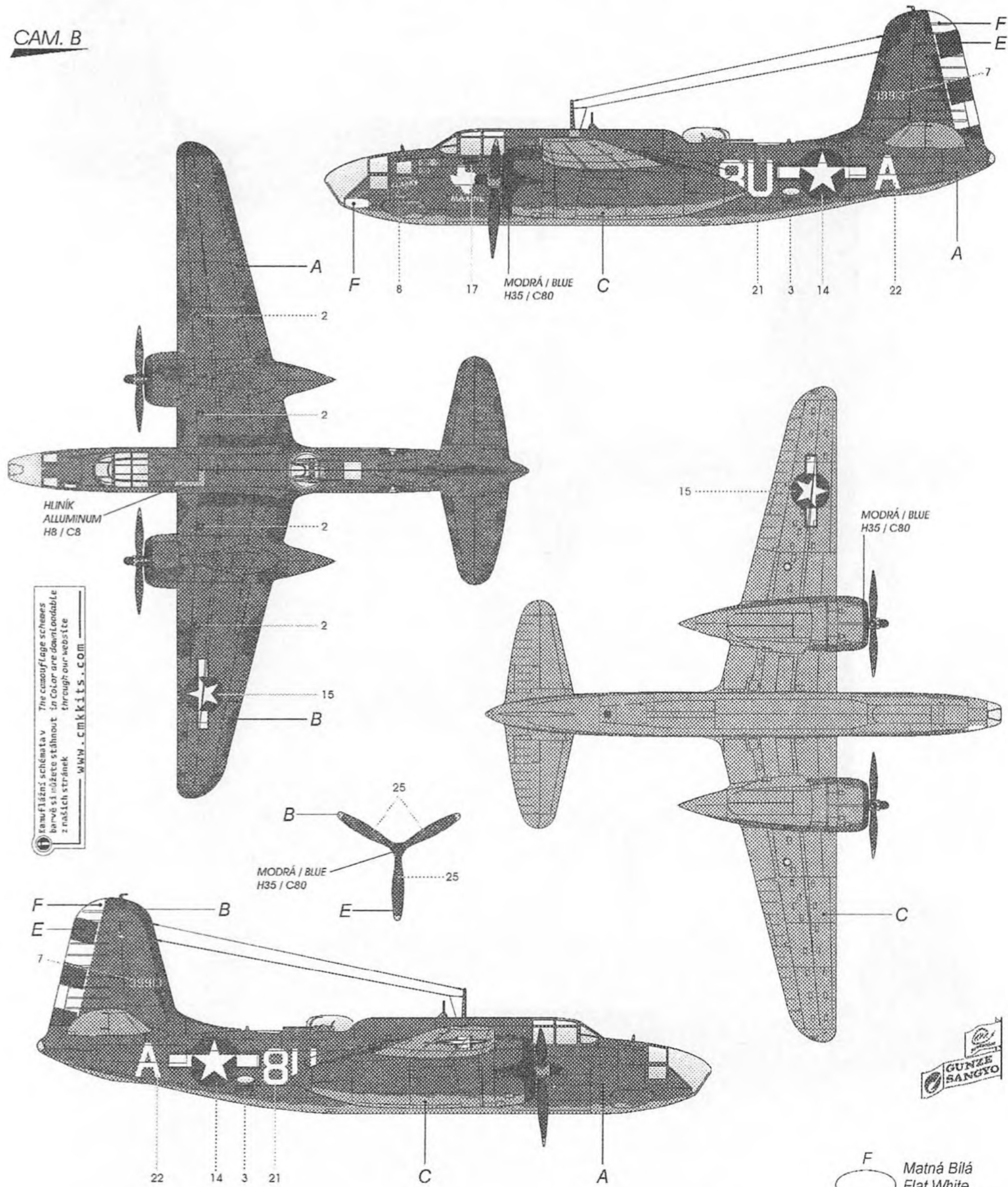

Kamufážní schémata v
 barvě si můžete stáhnout
 z našich stránek
 WWW.CMKKITS.COM

- | | | | | | |
|---|---|--|--|--|---|
|  <p>A
Olivová 41
Olive Drab 41
H52 / C12</p> |  <p>B
Střední zelená 42
Medium Green 42
H302 / C302</p> |  <p>C
Světle šedá 43
Neutral Grey 43
H53 / C13</p> |  <p>D
Žlutá
Yellow
H329 / C329</p> |  <p>E
Matná Černá
Flat Black
H12 / C33</p> |  <p>F
Matná Bílá
Flat White
H11 / C62</p> |
|---|---|--|--|--|---|

A-20J, 43-9639/18, "Princess Ruthie", 84. bombardovací squadrona, 47. bombardovací skupina, Itálie, 1944. Stroj patřil původně 86. Bombardovací squadroně, což dokládá prosvítající původní číslo pod "bílou 18" na ocasní ploše.

A-20J, 43-9639/ 18, "Princess Ruthie", 84 BS, 47 BG, Italy, 194. The machine originally belonged to the 86 BS since the original tail code still shows through the new "White 18".

CAM. C

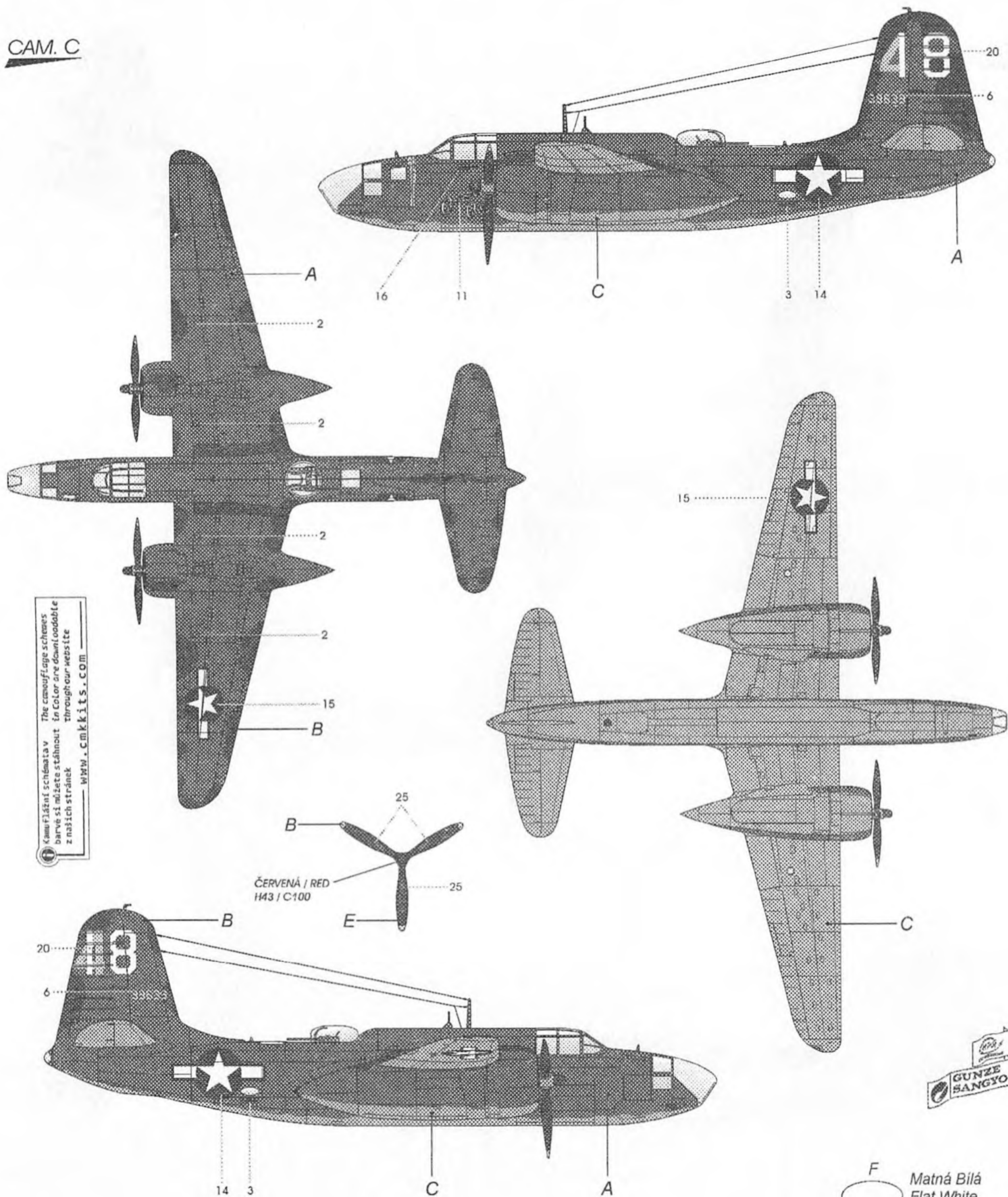

Kamufážní schémata v The camouflage schemes barvy si můžete stáhnout in Color are downloadable z našich stránek through our website WWW.CMKKITS.COM

- A**

 Olivová 41
 Olive Drab 41
 H52 / C12
- B**

 Střední zelená 42
 Medium Green 42
 H302 / C302
- C**

 Světle šedá 43
 Neutral Grey 43
 H53 / C13
- D**

 Žlutá
 Yellow
 H329/ C329
- E**

 Matná Černá
 Flat Black
 H12/ C33
- F**

 Matná Bílá
 Flat White
 H11/ C62



R-20 "Bororós" (A-20K, ex-USAAF 44-390), ser. no. 6080, 1°/10° GAv, Cumbica, FAB (Brazilské vzdušné síly), 1952 - 1954. Nevyzbrojený stroj byl používán k fotografickým akcím. Byl zničen při havárii 22.4. 1954 u Florianópolisu.

R-20 "Bororós" (A-20K, ex-USAAF 44-390), ser. no. 6080, 1°/10° GAv, Cumbica, FAB (Brazilian AF), 1952 - 1954. The aircraft was stripped of all armament and served for photo-reconnaissance purposes. It was destroyed during emergency landing near Florianópolis on April 22, 1954.

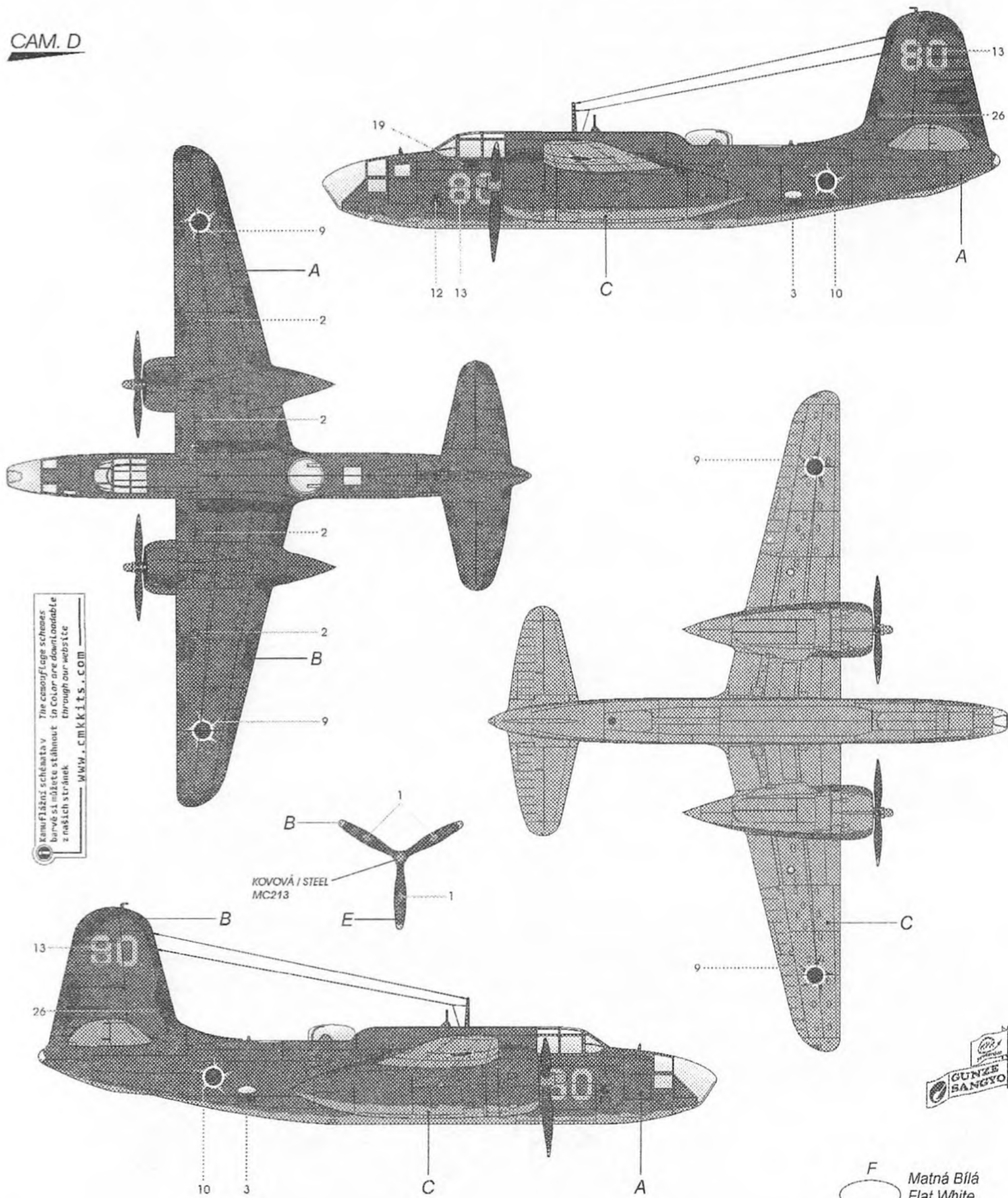
CAM. D

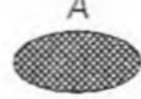
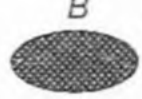
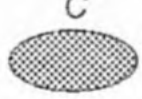
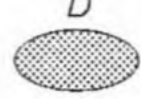
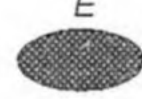

Kamufliážní schémata v The camouflage schemes
 barvy si můžete stáhnout in color are downloadable
 z našich stránek through our website
 www.cmkkits.com

- | | | | | | |
|---|---|---|--|--|---|
|  <p>A Olivová 41
Olive Drab 41
H52 / C12</p> |  <p>B Střední zelená 42
Medium Green 42
H302 / C302</p> |  <p>C Světle šedá 43
Neutral Grey 43
H53 / C13</p> |  <p>D Žlutá
Yellow
H329 / C329</p> |  <p>E Matná Černá
Flat Black
H12 / C33</p> |  <p>F Matná Bílá
Flat White
H11 / C62</p> |
|---|---|---|--|--|---|



1/72

**Special
HOBBY**

limited run plastic kits

High quality injected plastic kits - short run/ Vstřikované modely - limitovaná série

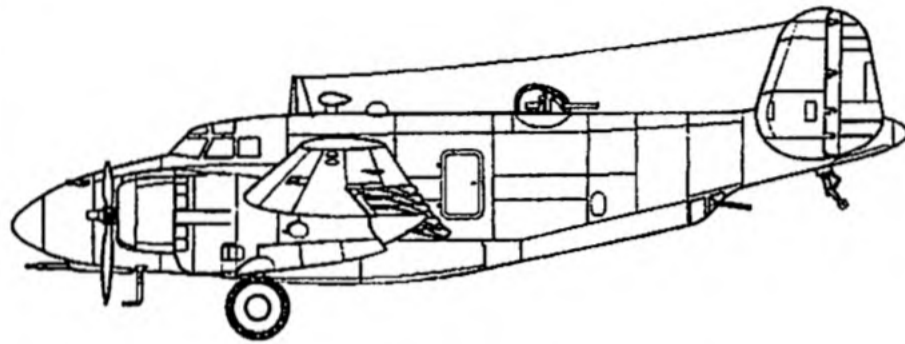

SH72093 PV-2 Harpoon U. S. NAVY

1/72

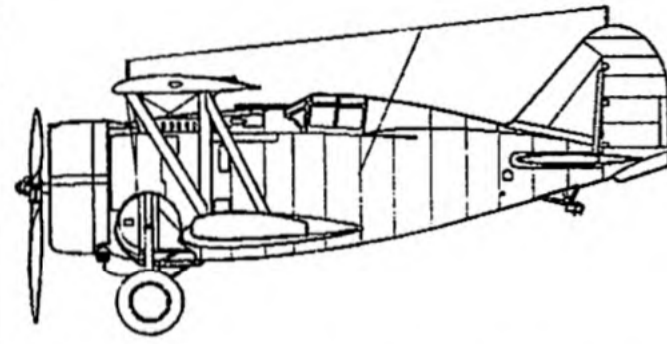

SH72106 F3F-2 "Flying Barrel"

1/72

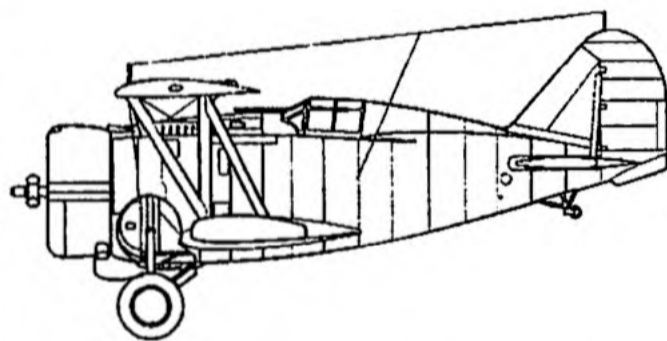

SH72109 F3F-2 "Last U.S. NAVY Biplane Fighter" 1/72

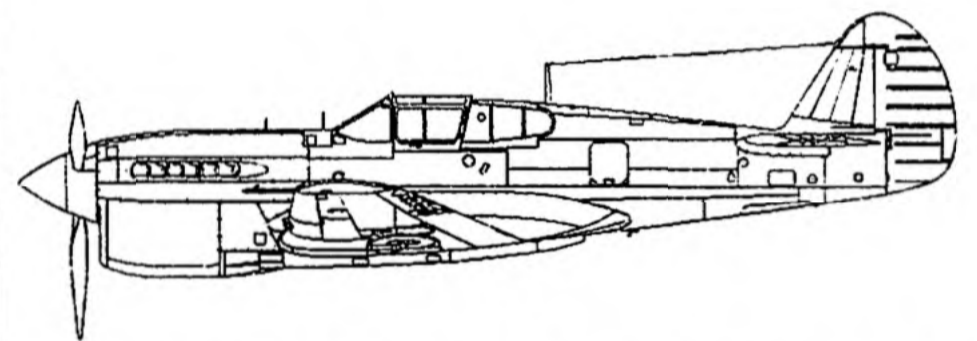

SH72149 P-40F Warhawk "Guadalcanal Hawks" 1/72

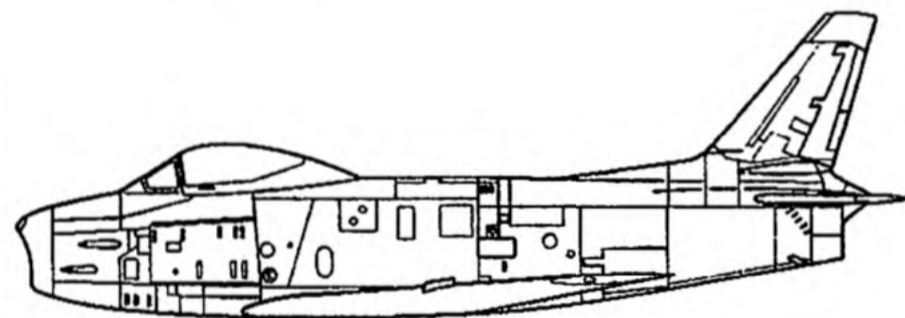

SH72120 F-86H Sabre Hog

1/72

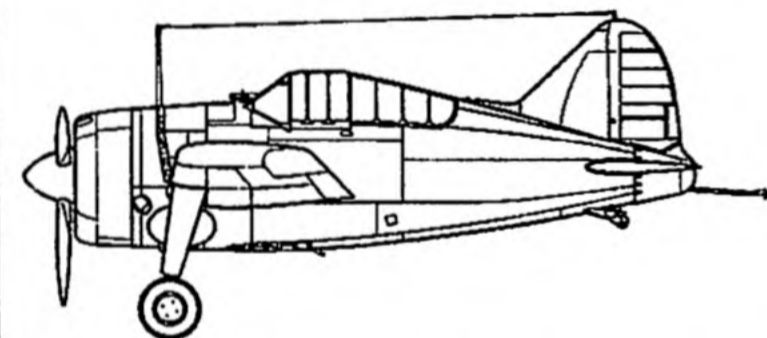

SH72133 F2A-2 Buffalo "Yellow Wing"

1/72

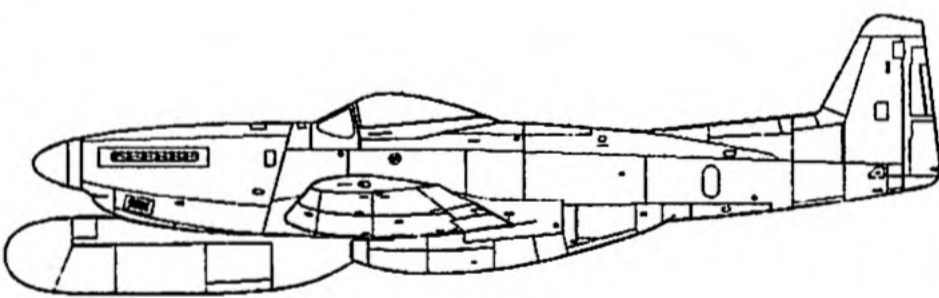

SH72200 F-82G Twin Mustang

1/72

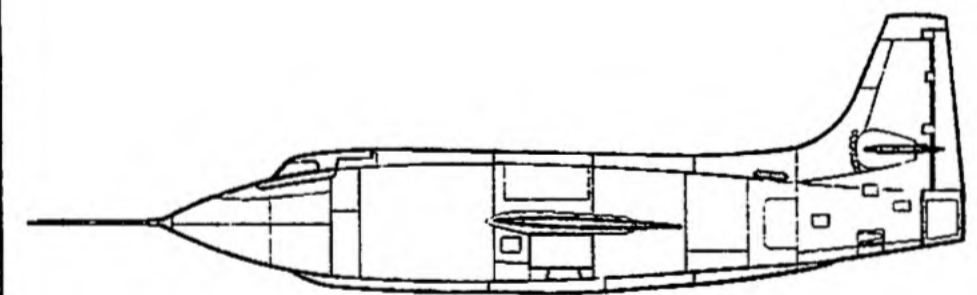

SH72158 X-1E "Last Model"

1/72

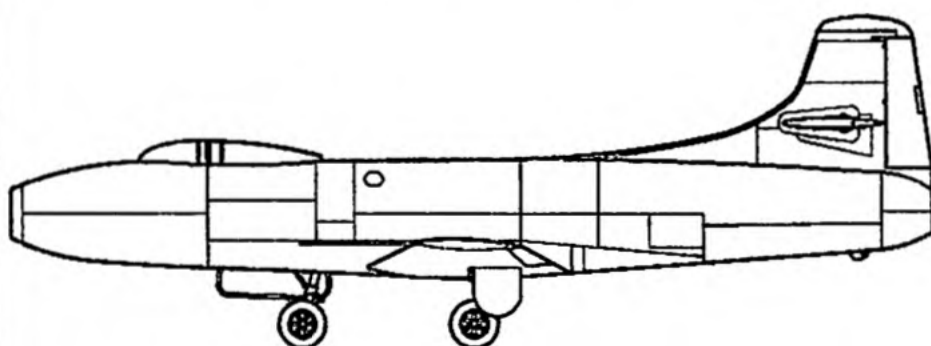

SH72159 D-558-1 Skystreak

1/72

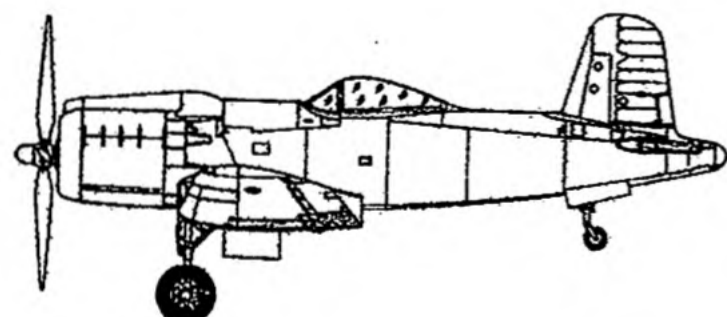

SH72166 F2G-1/2 Super Corsair Racer

1/72

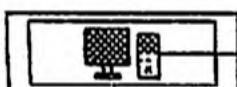

Navštivte naše stránky a e-shop www.cmkkits.com

Visit an official website and e-shop at www.cmkkits.com

