

RAF Victor K2 Detail Set

If you can get hold of a copy - Aeroguide No.11 on the Victor, is one of the best in this excellent series, and will give you both a photographic and a painting reference for many of the parts supplied in this set.

The part numbers on the sketches that are encircled relate to kit part numbers - whilst all other numbers refer to parts in this set.

It is important to note that there on the etched fret some items are only fitted in the context of our Victor B1/K1 set, and obviously, any reference to these items on the constructional drawings should be ignored. Before adding any detail, the resin-moulded inner wing leading edge/intake units should be fitted, converting the kit as shown in the diagram. Otherwise, there is no set order to the remainder of the assembly.

Air Brakes - Parts 47 & 48 should be laminated back to back, as should parts 49 & 50. They are replacements for the main sections of kit part 33. You should remove all but 1mm of kit part 33 on each side of the central pivotal section. The two etched sub-assemblies should then be fitted to the rear faces of the remaining 1mm extensions on kit part 33, noting that the parts with the square cut-outs [47 & 49] are fitted facing rear-wards - opposite to the configuration of kit part 33 [prior to modification]. The tags on the outer ends of the etched units being fitted to kit parts 8 & 9, after etched overlays [51] have been fitted over the central sections of these parts.

The etched FOD guards supplied can be added into these resin mouldings. If you wish they could be used as a diorama item beside your model, perhaps placed in one of the airfield bins supplied in our RAF Diorama Set. For the complete range of RAF ground support equipment marketed by Flightpath, make sure you have our latest catalogue.



Trefacwn Fach,
Llanrhian,
St. Davids, Pembrokeshire,
SA62 6DP, Wales, UK

www.djparkins.com

These instructions refer to the use of Airwaves [ex-DB Productions] ejector seats but there are alternatives, available from Aeroclub, which will do equally as well.

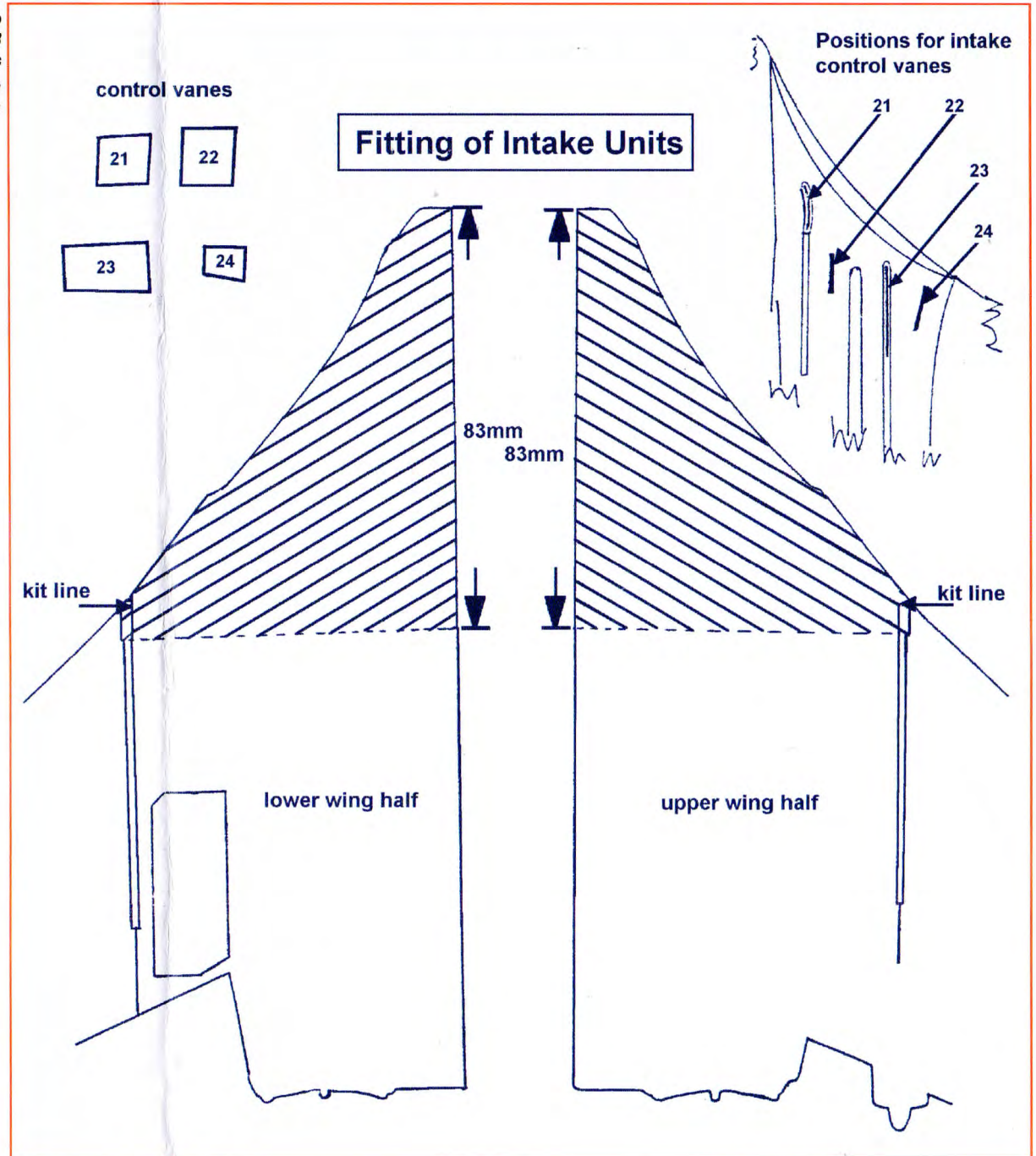

Cockpit Canopy - it may be best to discard the moulded canopy altogether, and to reglaze our etched framing using thin acetal material - glued to the inside

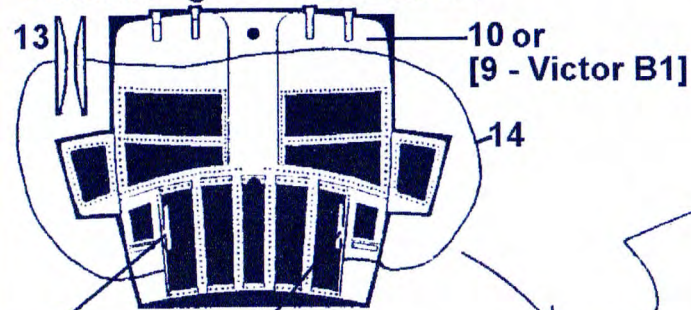

add part 11 [12 on other side]

replacement Pitot Head casting - later period



Flight/Groundcrew Intercom Lead [18] - used for communications during start-up. The socket for this lead is marked on the kit moulding

fit parts 19, or 20 [K.2 later period only] as a replacement to the nose transparency for a current Victor

3 [added to top section of part 4]

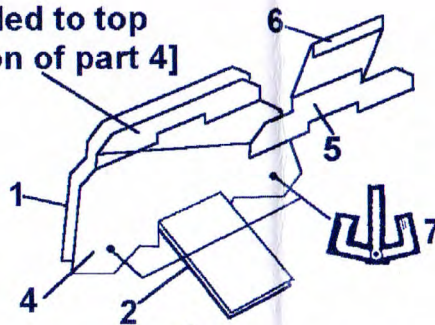

Cockpit - it is recommended that the kit ejector seats are replaced with the [ex-DB Conversions] Mk.3/4 seats. Firing Handles are supplied for these [parts 8]



Access Ladder - to replace kit part 34

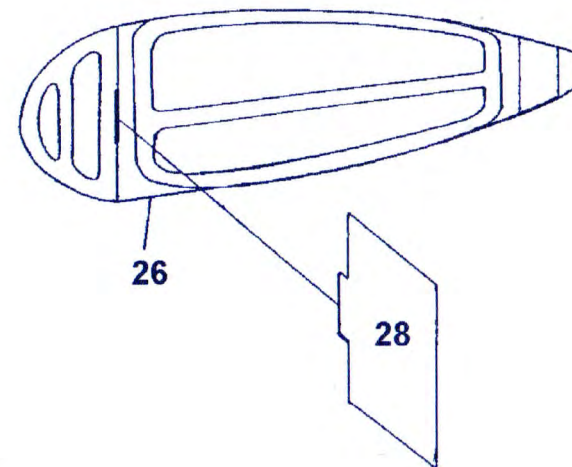
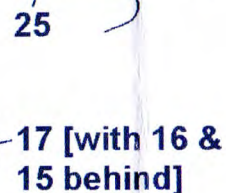

Fod Guard assys.- Mk.2 only
These can be fitted into resin intakes if desired - part 27 is Starboard unit

Note - Parts 30 are etched vortex generators - to replace the moulded items in the kit

Tanker Versions Only

Hose Drum Unit - note that kit parts 10/11 [when joined] are totally wrong in cross-section, and if using our rear fascia for this part, you will have to 'build out' the unit accordingly. The 'scrunched-up' drogue basket [42] should be fitted inside the tunnel formed by joining kit parts 10/11 - using the folded back tag on the bottom of the part

54 is provided as an etched-through alternative to part 53 - this can be glazed from behind with coloured glazing

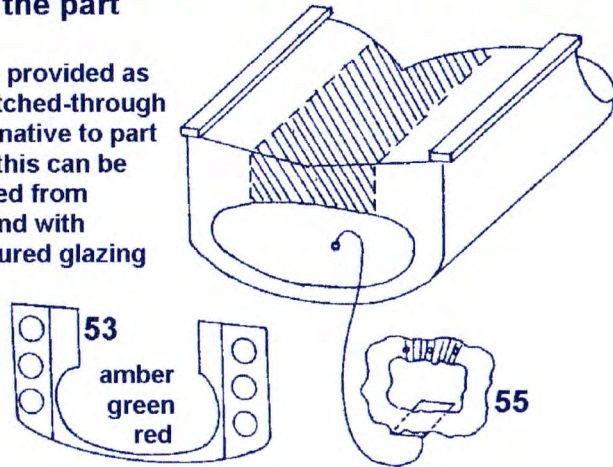

Refuelling Pods

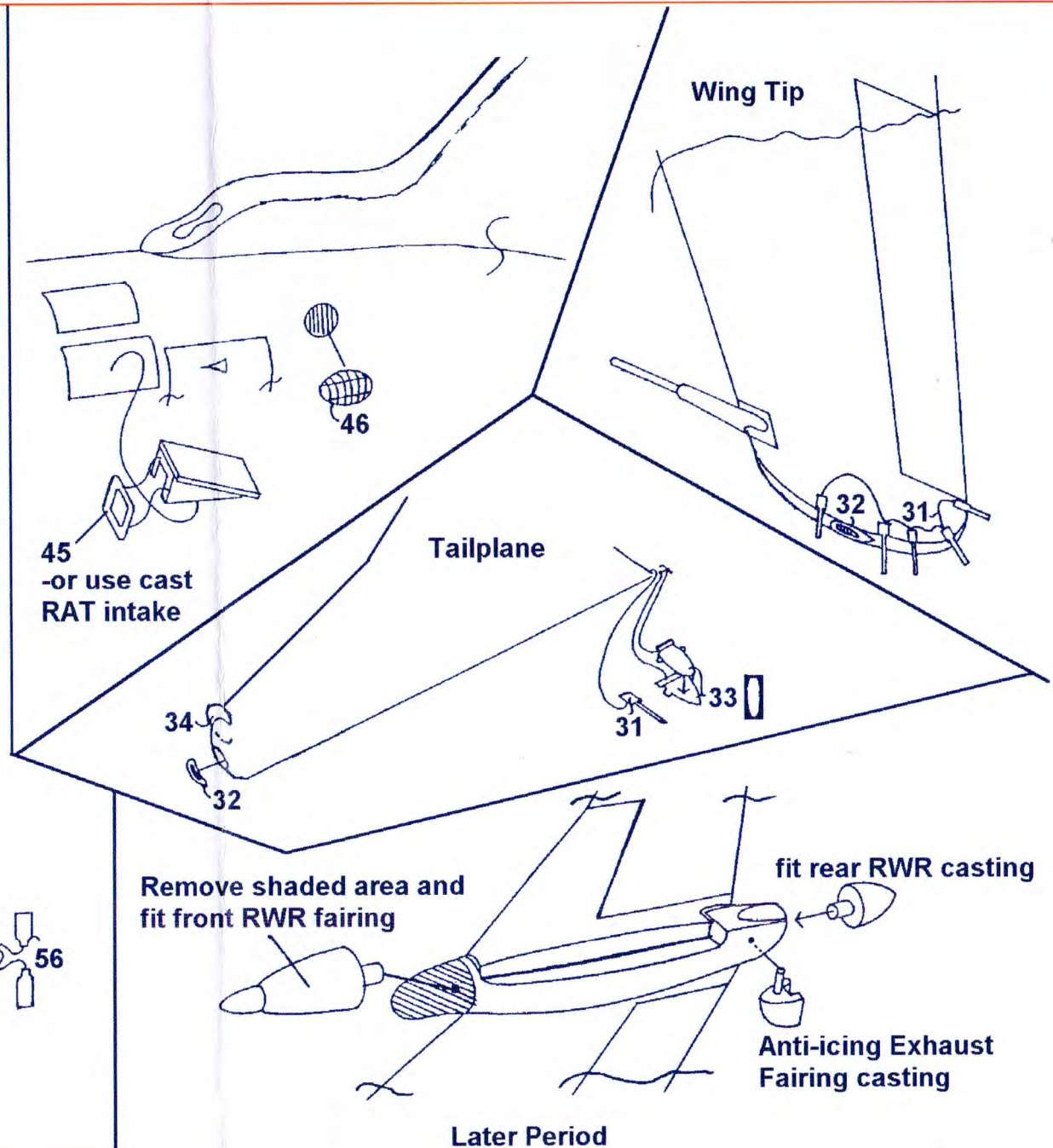
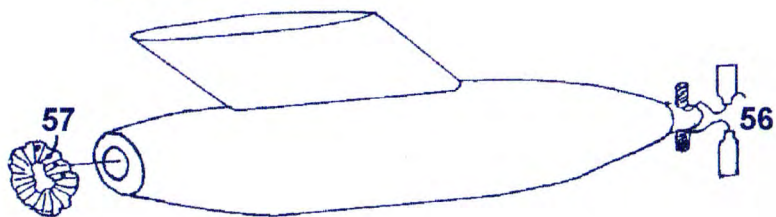

Parts 37/38 - replaces kit part 24

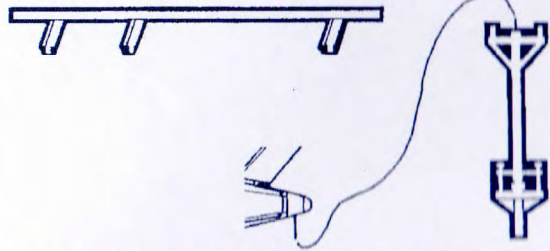

Compass Alignment Rod [52] - this is fitted into underside of rear fuselage whilst performing compass swings

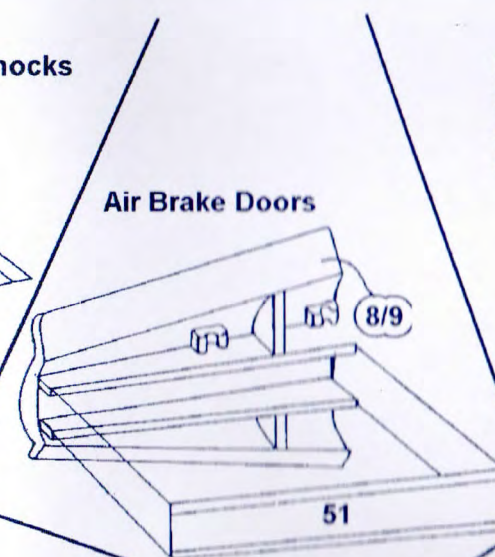
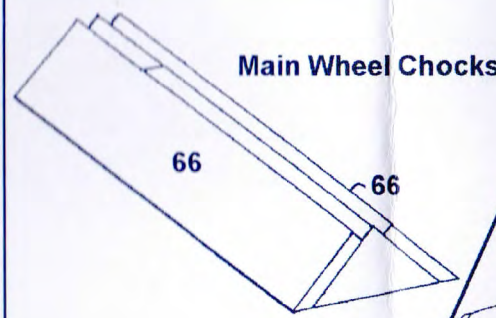

Main Undercarriage - starboard unit illustrated - mirror image for port side. Remove shaded areas from kit parts 15 & 20

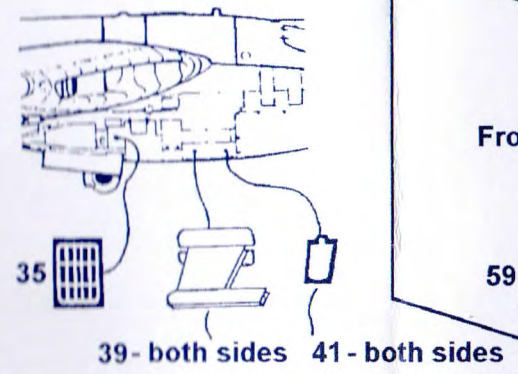
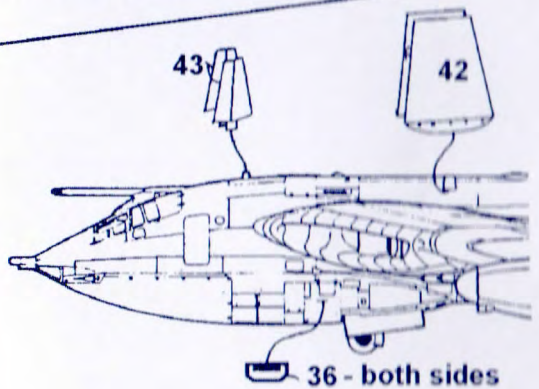
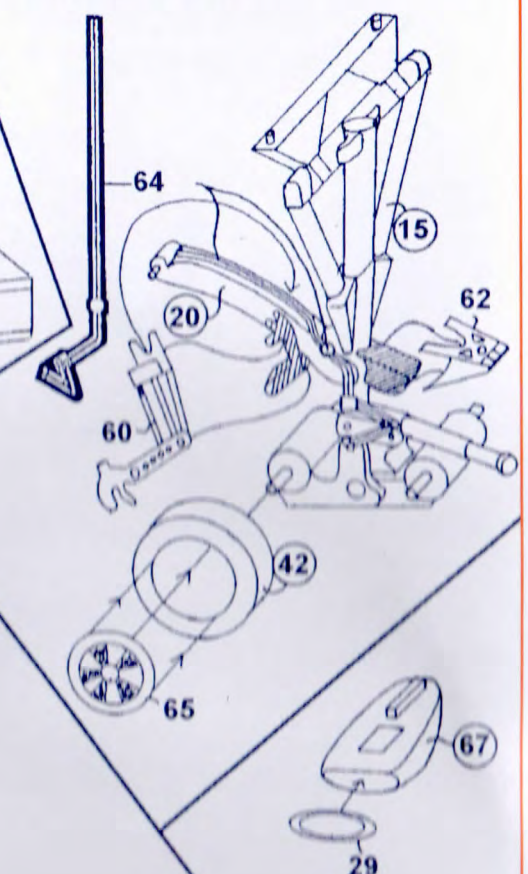

Front Undercarriage

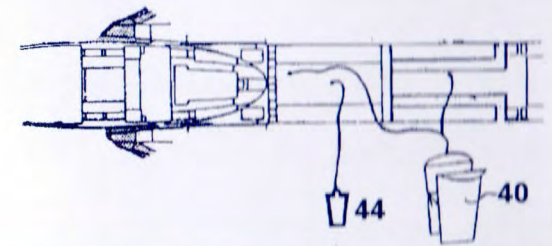
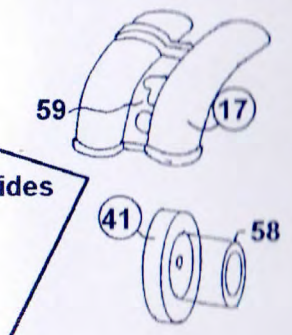

Victor K2 Photo Walk-Round on following two pages
Several shots relate to parts in this set - others do not - all should be useful

Photographs are Copyright - David J. Parkins

