

# GERMAN 50TON TYPE SSys Köln FLATCAR SCHWERER PLATFORMWAGEN

ドイツ軍用シムス50ケトン  
大型平台貨車  
德國50噸SSYS平板運輸車

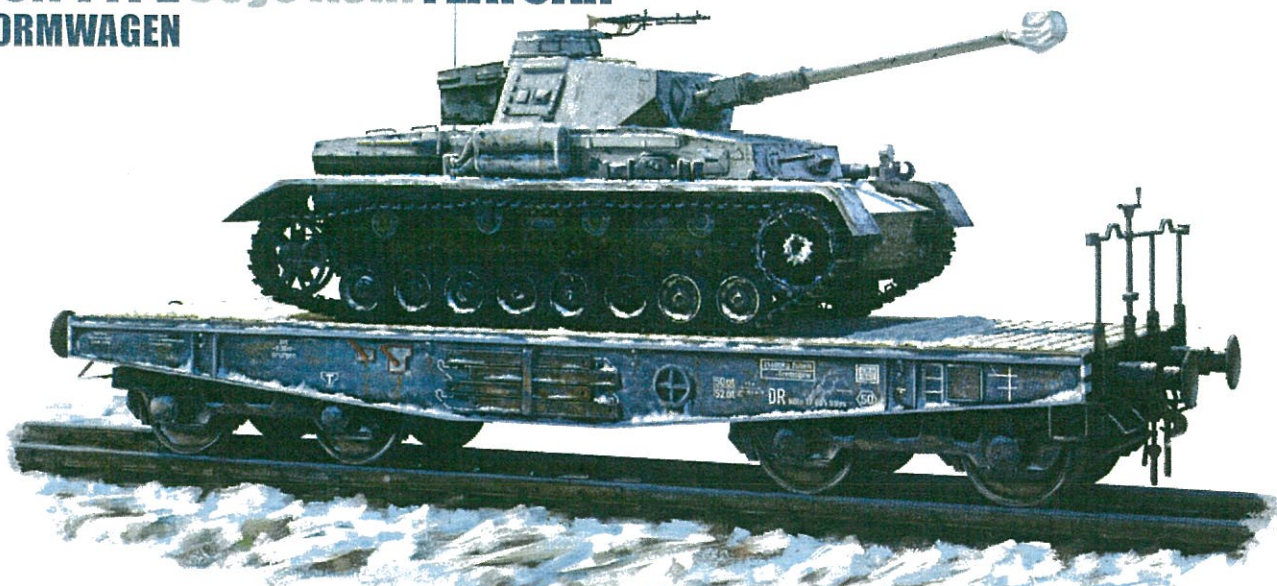

Germany has maintained a well-developed railway network since the late 19th century. This railway network had supported Prussian and German operations since the Pruden War (1864) and even the German General staff had taken railway capacity into account in planning many campaigns. By the time of World War II, in addition to troops and basic logistics, German railways had to transport all kinds of large-scale military equipment, especially the armored units that served as the main force in the blitz and later defensive operations. It can be said that the domestic and occupied areas of the railway during World War II Germany is the basic guarantee of logistics and combat effectiveness. At the end of the war, the Allied bombardment destroyed all the railways in Germany, and the defeat of the German army was inevitable. In this sense, the German armored units of the railway transport is the basic premise of its combat effectiveness.

During World War II, the standard flat trains common in the German army were roughly divided into three categories: light (under 30 tons) two-axle railway wagons; 40-50 ton TSSys four-axle flat trains; and 80-ton SSyms six-axle flat trains. Generally speaking, during World War II, the bearing weight of railway wagons was about 15 tons, and the Ommr bearing capacity of those two axles was 30 tons. The four-axis SSys load is 60 tons (50 tons is the upper limit), the six-axis SSyms load is 90 tons (80 tons is the upper limit), can carry 56 tons of TIGER, 72 tons of KING TIGER, 78 tons of ELEPHANT.

德意志地區從19世紀後期開始就壹直保有發達的鐵路網絡。這個鐵路網絡從普丹戰爭（1864年）開始就壹直支撐著普魯士和德國的戰爭行動，甚至德軍總參謀部在謀劃許多戰役時，都要把鐵路運力作為相當重要的考慮因素。到了二次大戰的時候，除了兵員和基本的後勤之外，德國鐵路還要承擔各種大型化軍事裝備的運輸，尤其是作為閃擊戰和後期防禦戰主力的裝甲部隊。可以說，國內和占領區的鐵路是二戰期間德國後勤和戰鬥力的基本保證。到了戰爭後期，盟軍的狂轟濫炸把德國境內的鐵路破壞殆盡，德軍的失敗也就不可避免。從這個意義上講，德軍裝甲部隊的鐵路運輸是其戰鬥力發揮的基本前提。

二戰期間，德軍常見的標準化平板列車大概分為三類：輕型（30噸以下）的兩軸鐵路貨車；40-50噸級別的SSys四軸平板列車；還有80噸級別的SSyms六軸平板列車。壹般而言二戰時期鐵路貨車的軸承重大概是15噸左右，那兩軸的Ommr承重是30噸，四軸的SSys承重是60噸（壹般裝50噸是上限），六軸的SSyms承重是90噸（壹般裝80噸是上限），可以運載56噸的虎式，72噸的虎王，78噸的象式。

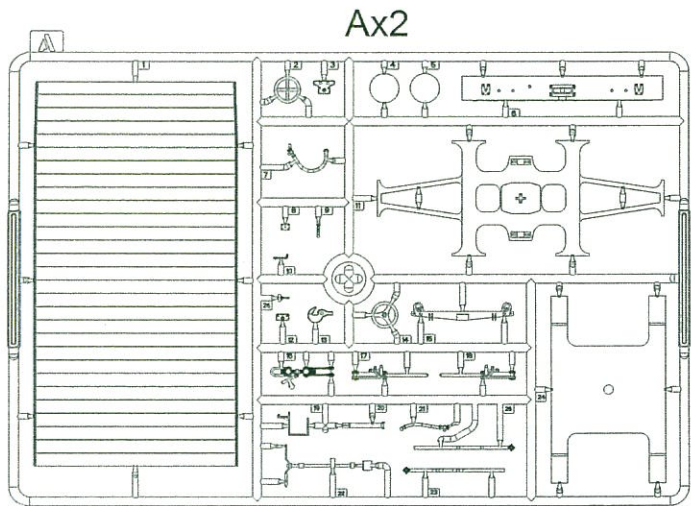

Ax2

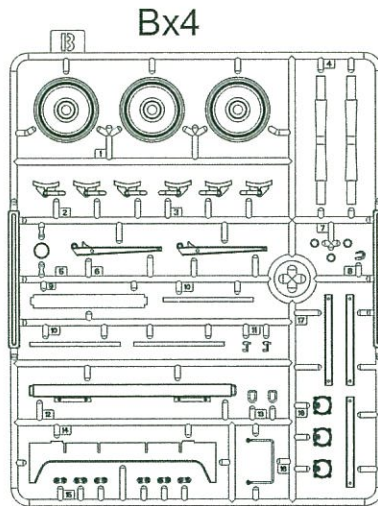

Bx4

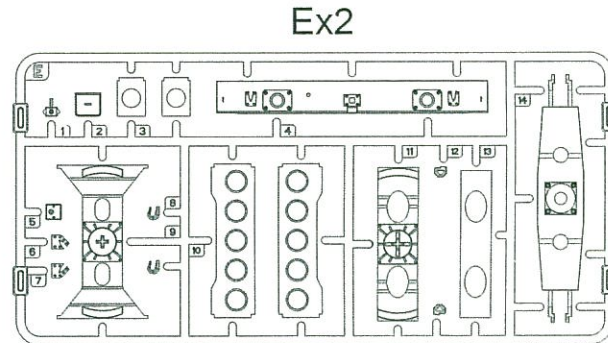

Ex2

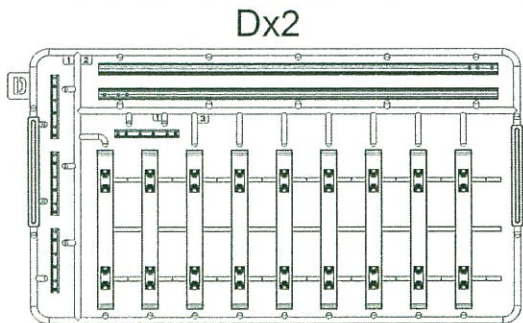

Dx2

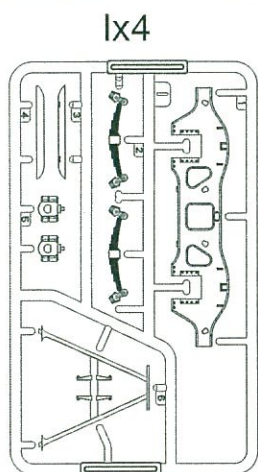

lx4

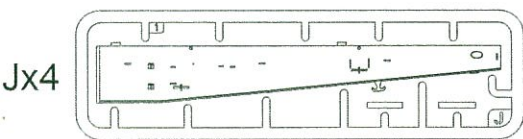

Jx4



Decal

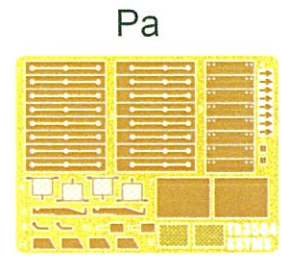

Pa



Pb

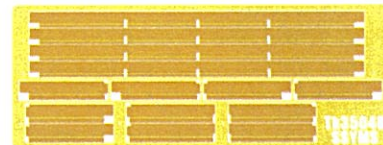

仅银橡胶叶及更高版含这套蚀刻片  
PE in silver version and above

Meaning of Icons

图示含义 アイコンの意味

- |  |  |  |   |
|--|--|--|---|
|  <b>FILL HOLE</b><br>填平孔洞<br>穴を埋めてください |  <b>OPEN HOLE</b><br>钻出孔洞<br>穴を開けてください      |  <b>OPTIONAL</b><br>可选择使用<br>どちらか選択してください   |  <b>REMOVE</b><br>切除<br>切り取ってください    |
|  <b>BE CAREFUL</b><br>小心注意<br>注意してください |  <b>APPLY DECAL</b><br>贴出水贴<br>デカールを貼ってください |  <b>DO NOT CEMENT</b><br>不用粘接<br>接着しないでください |  <b>INSTANT GLUE</b><br>速干胶<br>瞬間接着剤 |



Wax2

仅铁橡胶叶及更高版  
含这套蚀刻片

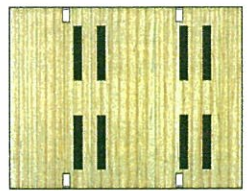

Wb

Wooden deck in iron version and above

1

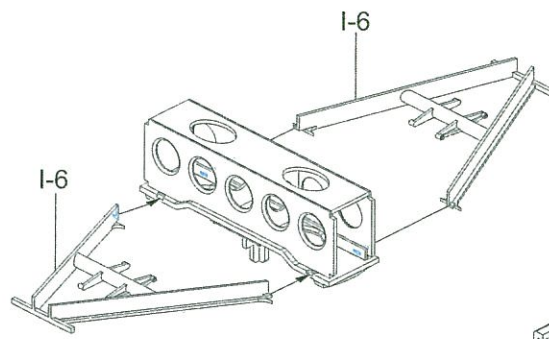
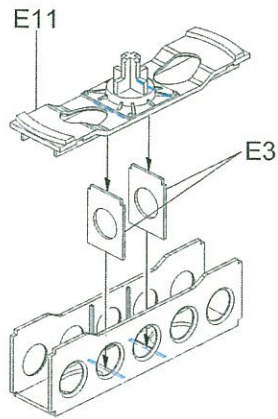
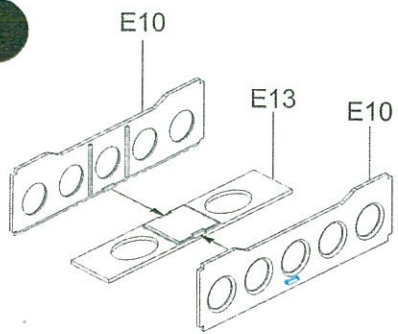

! 剎車片分左右  
Keep this side outside

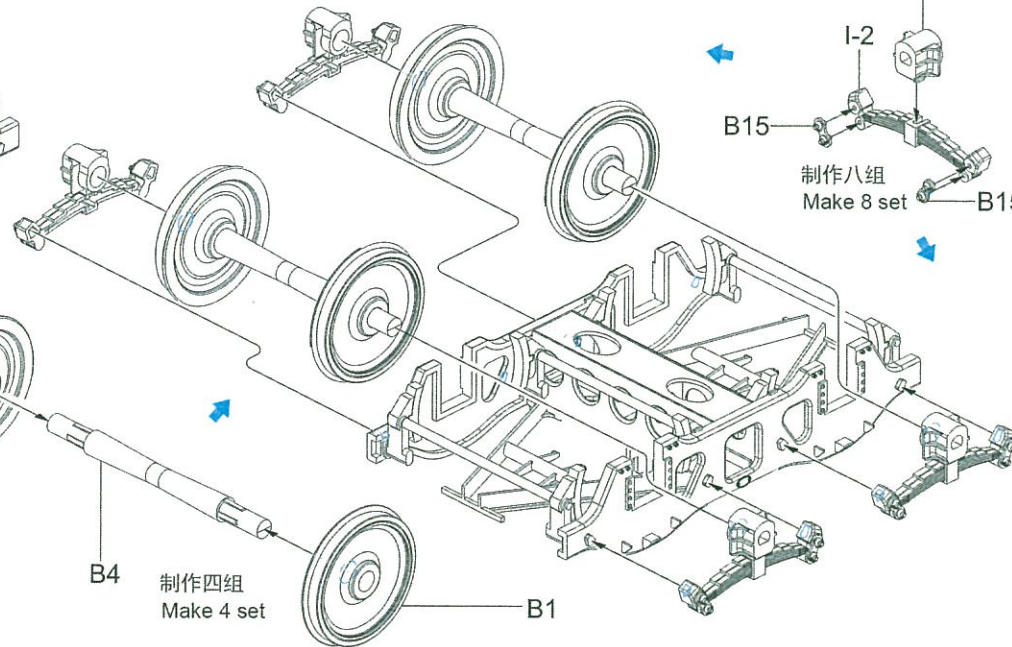
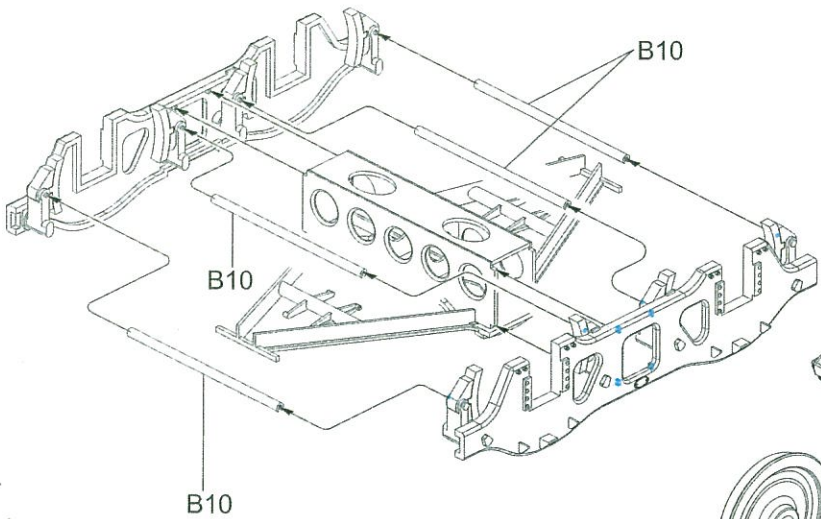
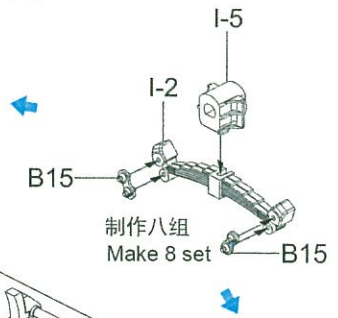
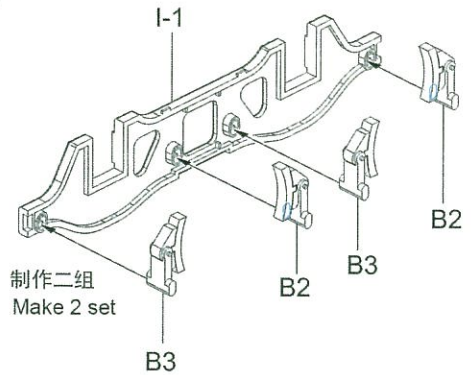

2

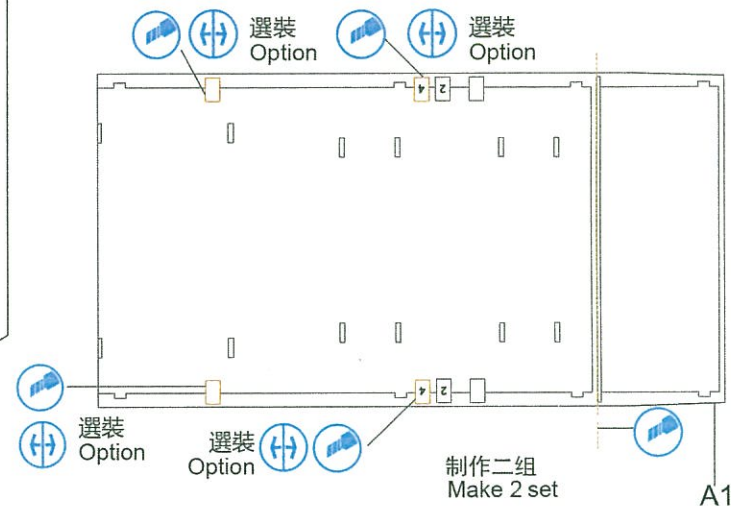
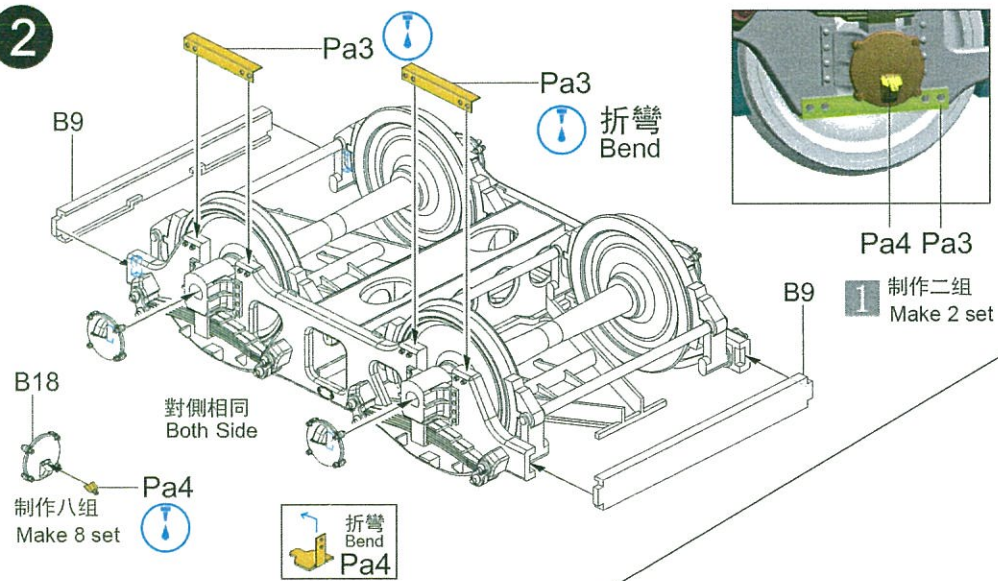

3

普通版 Normal Version

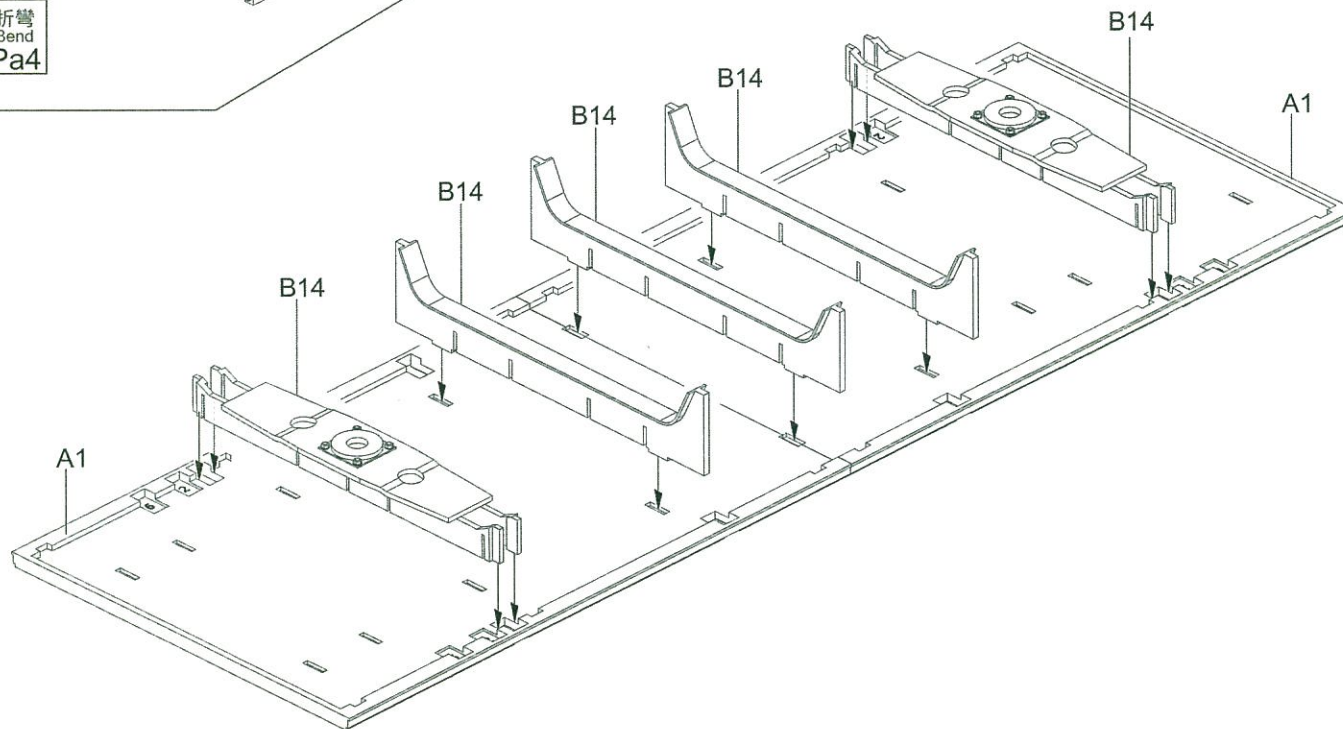

4

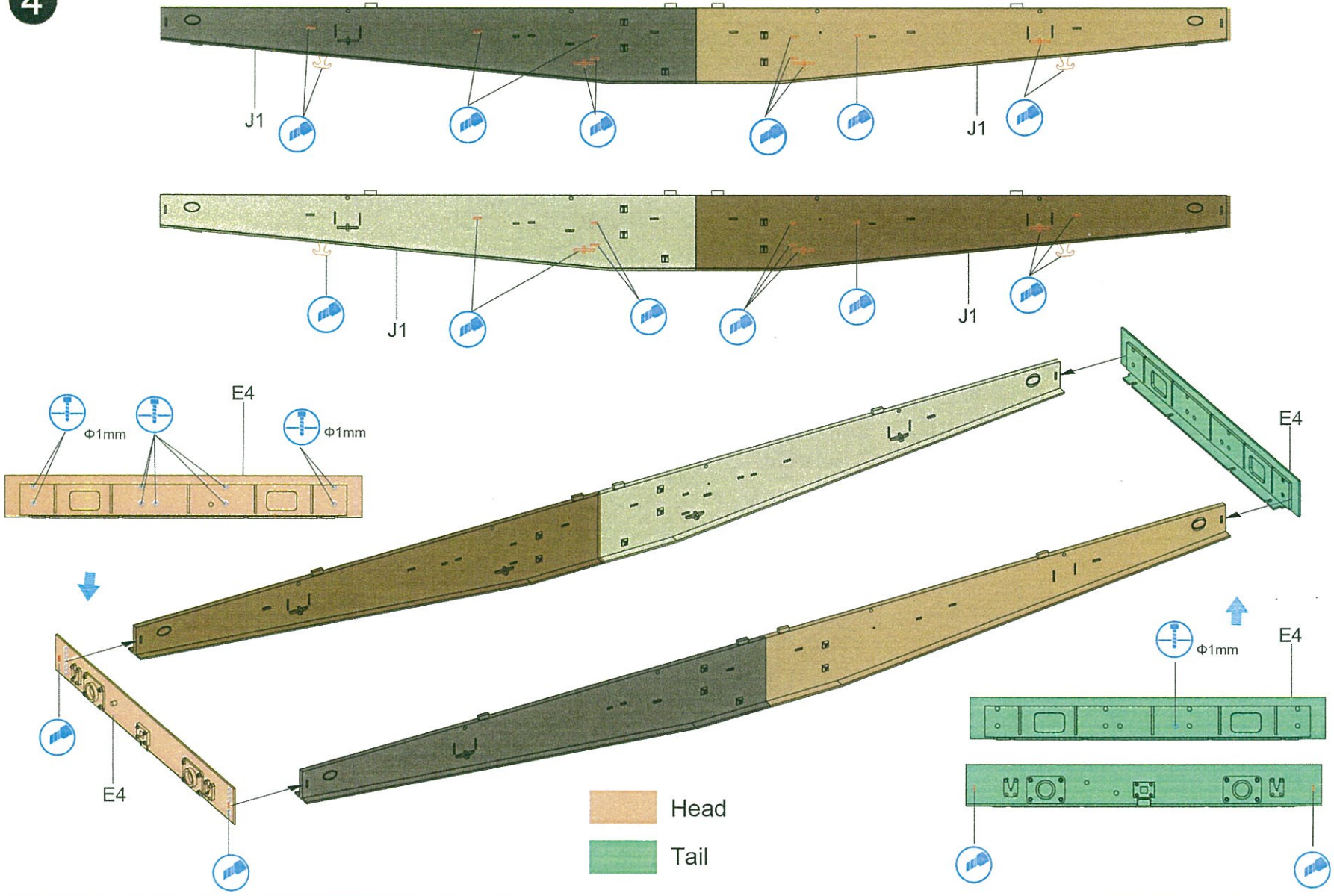

5

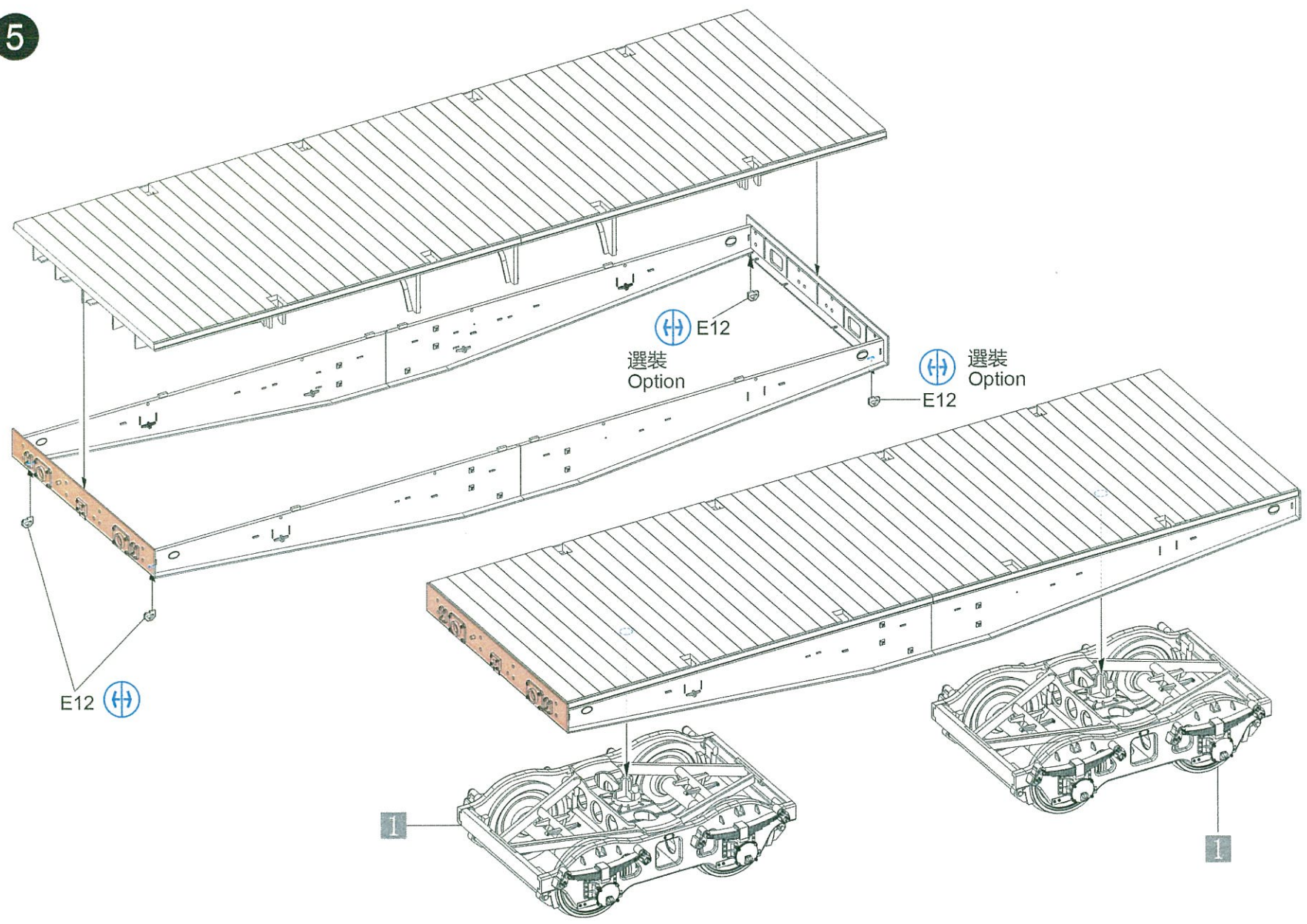

6

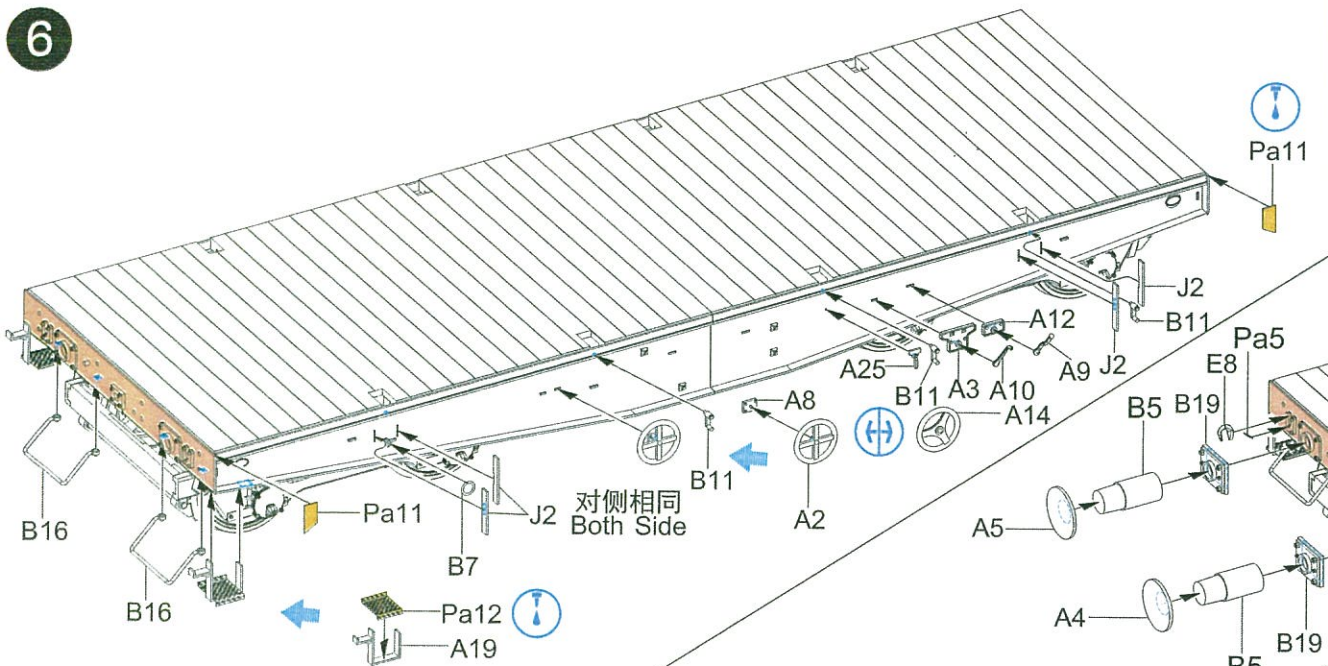

7

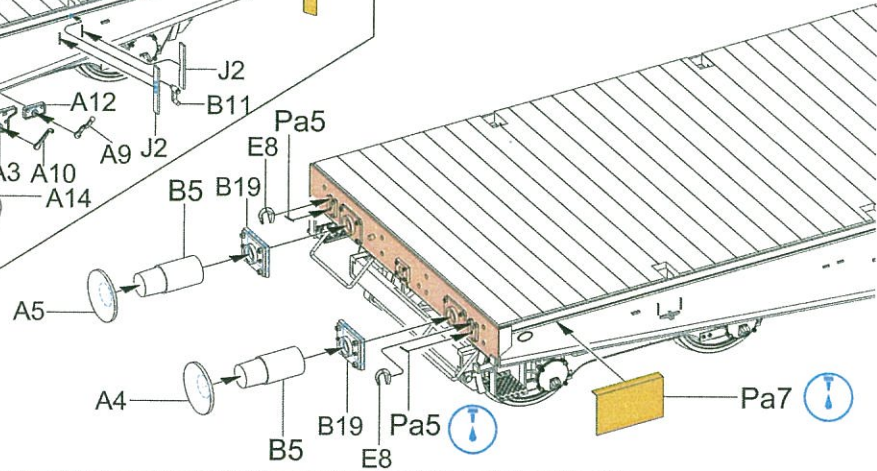

8

Hook Position I

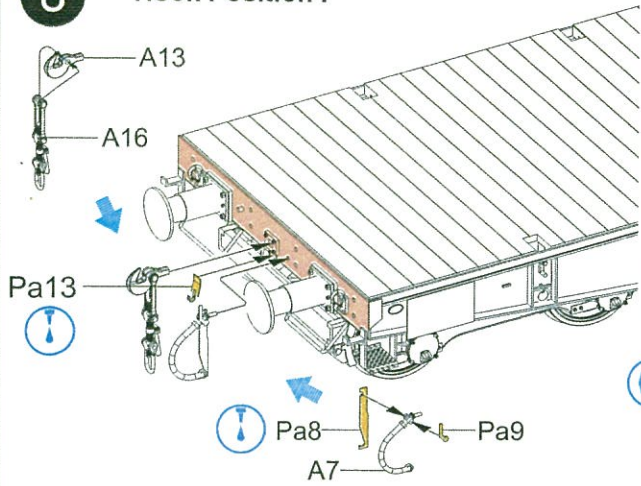

Hook Position II

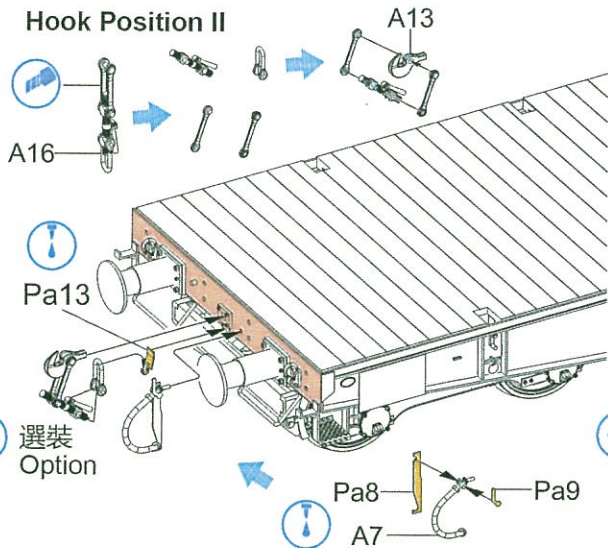

Hook Position III

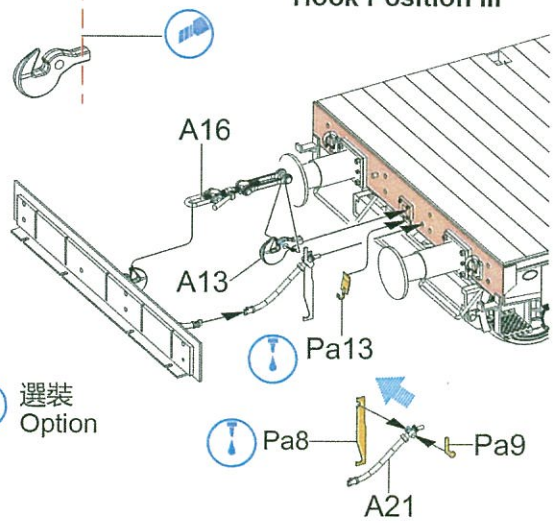

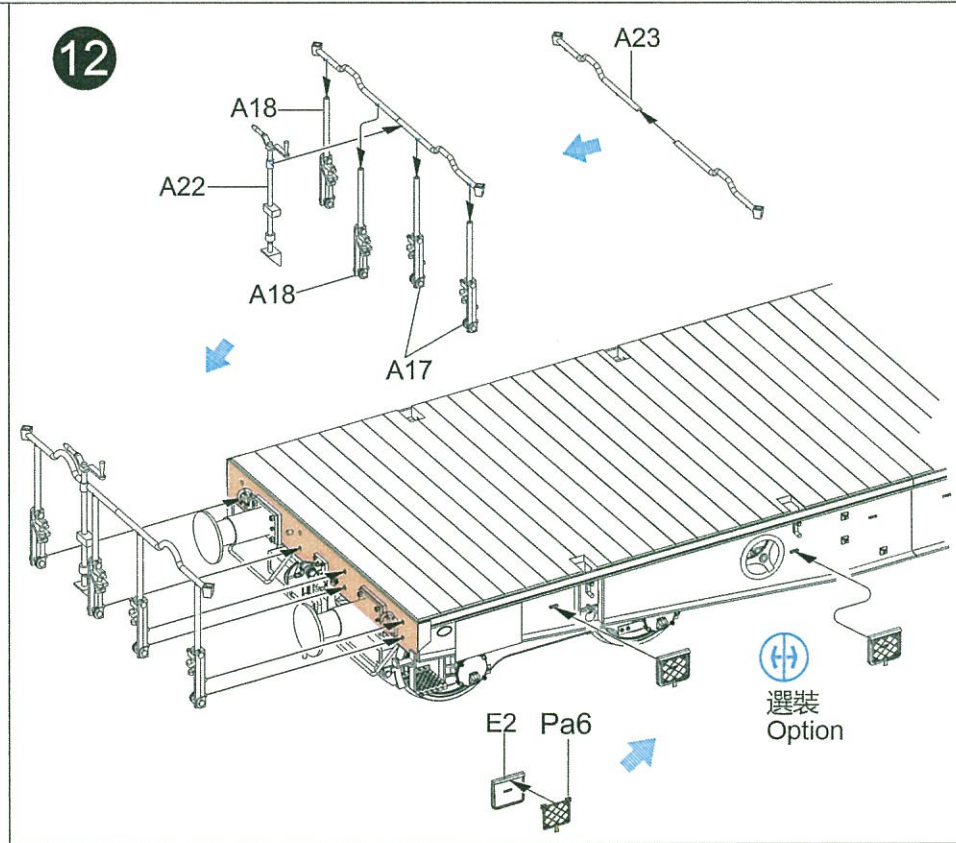
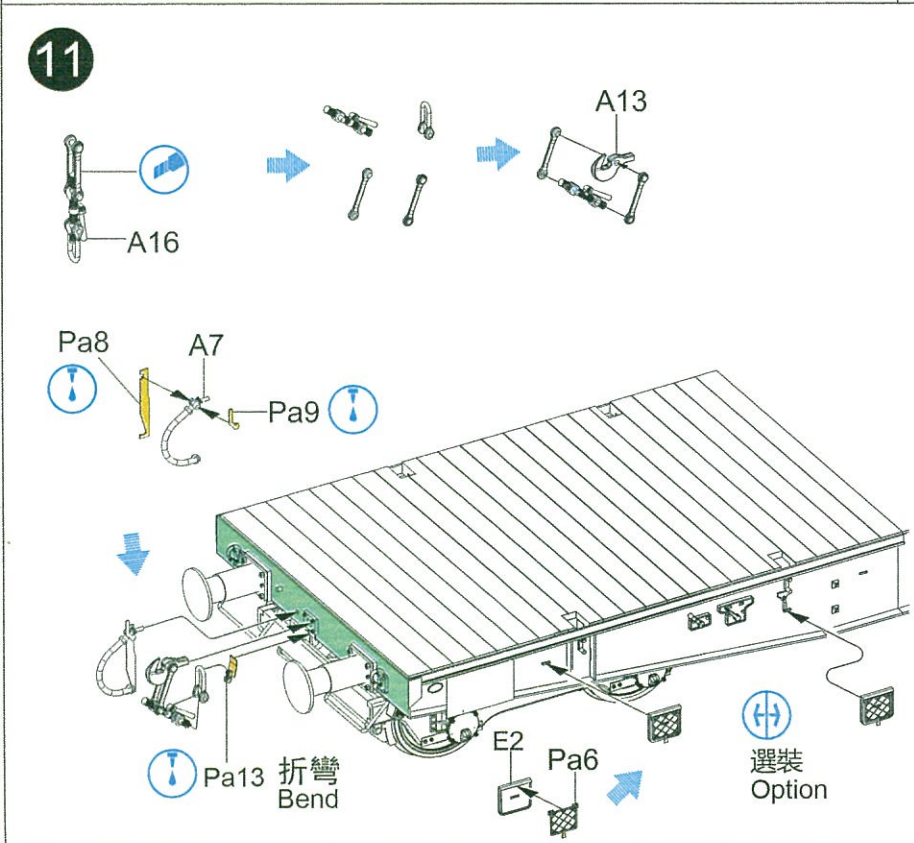
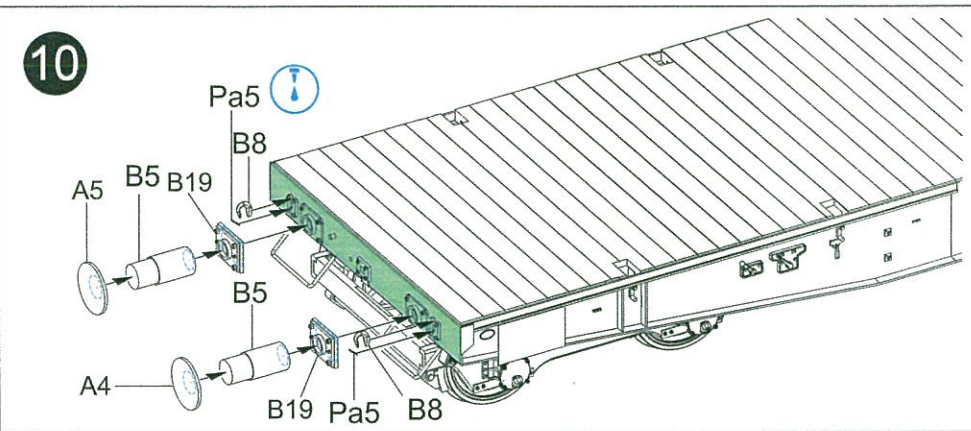
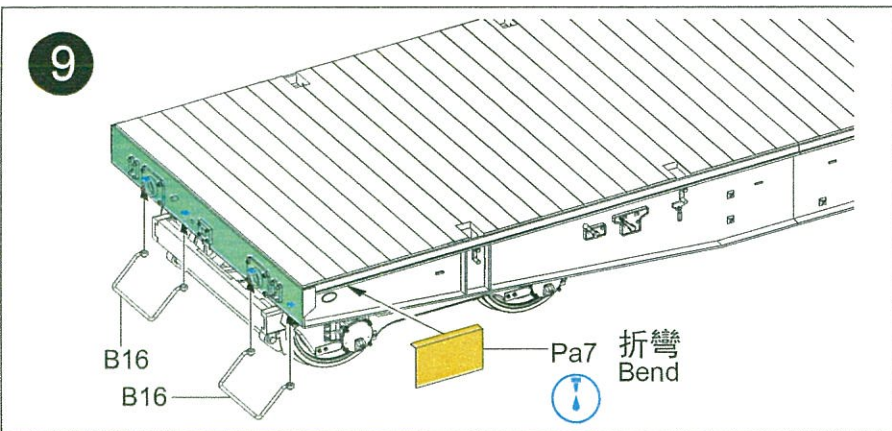



13

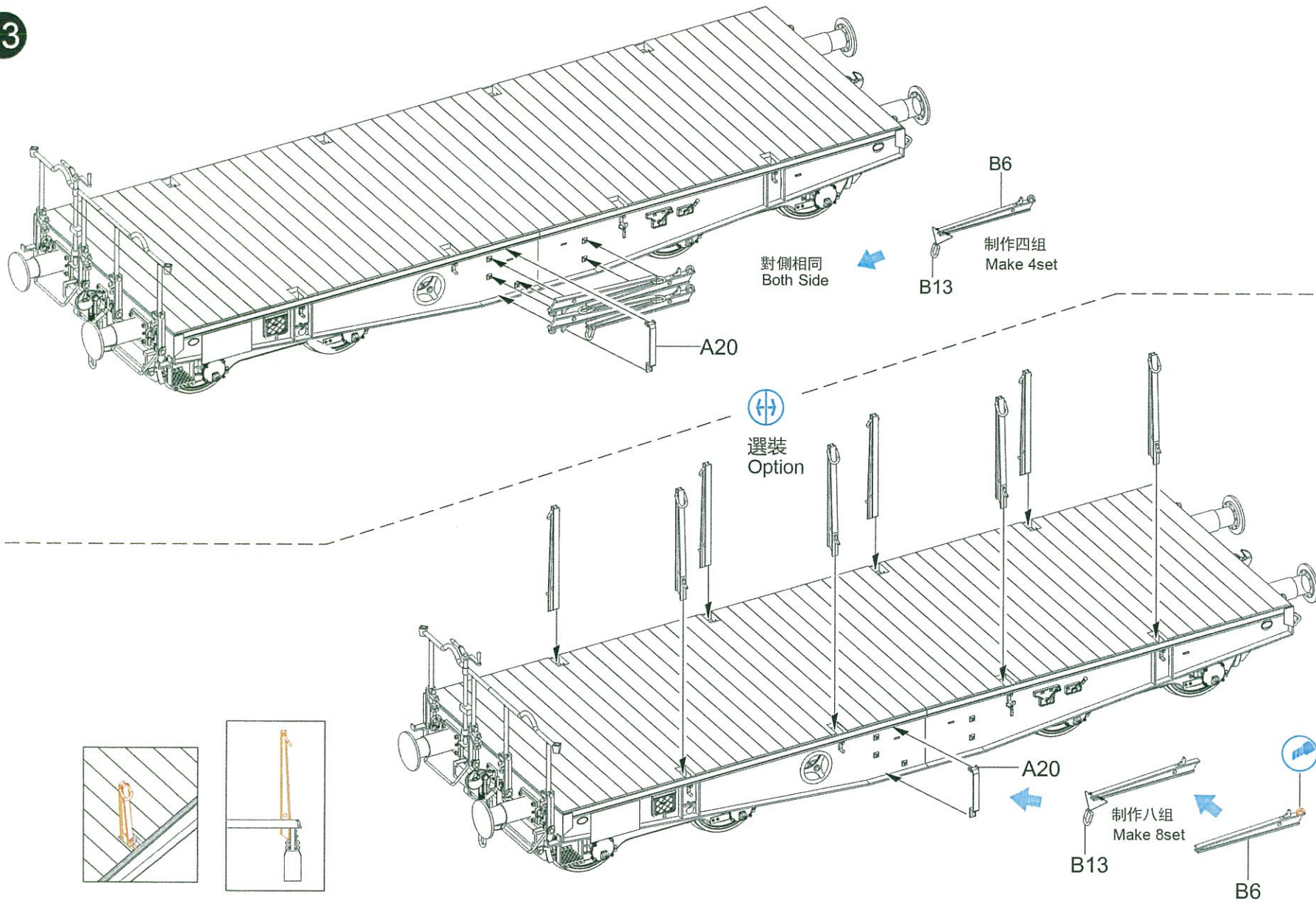

**14** 铁橡胶叶版  
Iron Version(TK3504-I)  
option for transporting cargos.

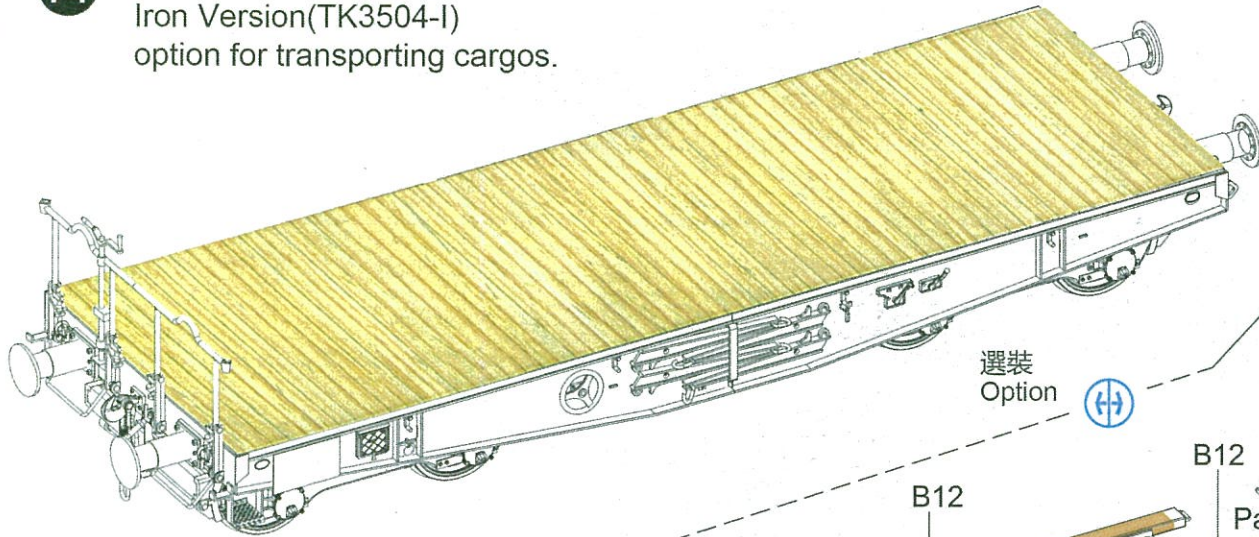

**15** 铁橡胶叶版  
Iron Version(TK3504-I)  
option for transporting AFV.

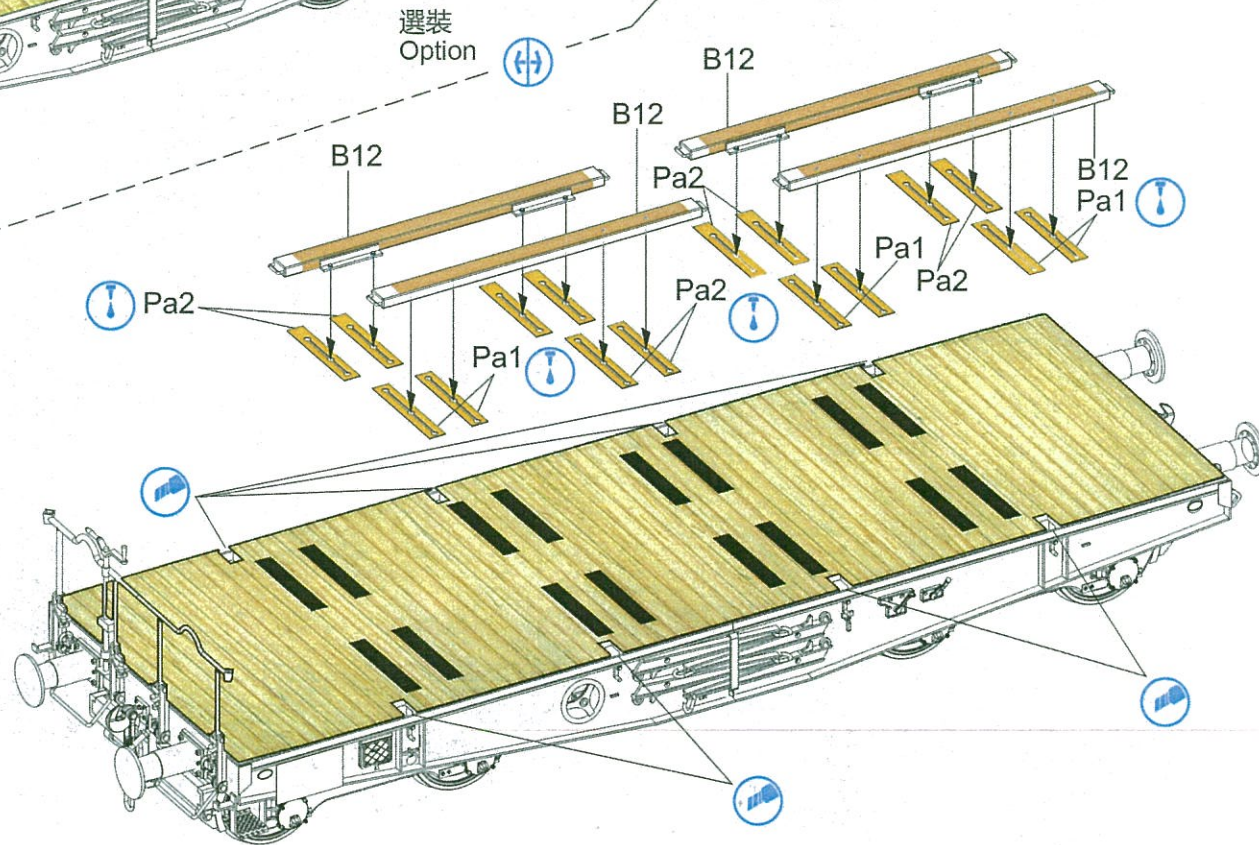

仅铁橡胶叶及更高版本赠送木甲板  
Wooden deck is include in  
TK3504-I, TK3504-S,  
TK3504-G



**T-MODEL**