

Kit No. 72557

## A-20B Havoc "MTO"

1/72

### HISTORIE

ⒸZ Americké letectvo usoudilo v roce 1937, že jednomotorové letouny kategorie Attack přestávají výkonově stačit. Vypsalo proto soutěž na nový dvoumotorový stroj této kategorie. Firma Douglas se stala vítězem této soutěže se svým návrhem model 7B. Původní návrh by postupně upravován, částečně také podle francouzských požadavků. Francie a další evropské země objednaly stroje označované DB-7A. Všechny tyto stroje byly poháněny motory R-1830. Po kapitulaci Francie převzalo další objednávky RAF. RAF tyto stroje pojmenovalo Havoc Mk.I. USAF a RAF požadovaly větší výkony a tak firma Douglas navrhla model DB-7B se silnějšími motory R-2600. Americké letectvo dostalo nejprve malou sérii A-20A Havoc s motory vybavenými turbokompresory a pak velké série verzí A-20B a A-20C. Ty se lišily zejména tvarem prosklení přídě. A-20B měla prosklení stupněné, A-20C šikmé. Tyto stroje odebíralo i RAF, které přidělilo verzi A-20B jméno Havoc Mk.III a verzi A-20C Havoc Mk.IIIA. Dále se tyto stroje dostaly do výzbroje SAAF, RAAF (ex holandské stroje pro Holandskou východní Indii) a Brazílie. V rámci Lend-Lease je dostal i Sovětský svaz. Na základě těchto strojů byly postaveny i noční stíhací verze, americká P-70 a britská Havoc NF Mk.II. Část britských strojů byla přestavěna na variantu Havoc Turbinlite se světlometem v přídě a neúspěšně použita k nočnímu stíhání.

A-20B/C se jako lehké bombardéry a bitevníky velmi osvědčily. USAF je nasadilo hlavně v Africe a Itálii, Britské RAF s Havocy zahájilo tzv. Non-stop ofenzívu, používalo je jako denní bombardéry i k nočním útokům na nepřátelská letiště a jiné cíle (Intrudery). Část strojů nasadilo také v Africe a Itálii. Australské RAAF upravilo své Havocy montáží pevných zbraní do přídě a nasadilo je s velkými úspěchy k bitevním útokům z malých výšek. Dalším vývojem vznikly verze A-20G/H/J/K vyzbrojené střeleckou věží místo hřbetního střeliště. Ty sloužily až do konce druhé světové války.

Rozpětí: 18,69 m, délka: 14,27 m, max. Rychlost: 560 km/h, dolet: 1740 km, dostup: 8800 m., nosnost pum: 940 kg, obranná výzbroj se lišila dle provedení pro USAF nebo RAF.

### HISTORY

ⒸZ In 1937 US Air Force HQ found out that single engined Attack aircrafts' performances are not sufficient. Therefore a competition was issued calling for new twin engined aircraft of the latter category. Douglas Co. won this competition with its Model 7B design. The original design was subsequently modified, partly according to the French requirements, too. France and other European countries had ordered these machines under designation DB7A. All these machines were powered by R-1830 engines. When the France had capitulated the rest orders were taken over by RAF that designated these machines as Havoc Mk.I. Both RAF and USAF had demanded better performances so Douglas Co. designed Model DB-7B powered by R-2600 engines with better output. First off USAF received small batch of A-20A Havocs powered by engines with superchargers and then bigger series of A-20B and A-20C. These versions differed from each other mainly by the nose glazing shape. A-20B had step like glazing but A-20C featured diagonal edge of the glazing. Both versions were also ordered by RAF that designated them Havoc Mk.III and Mk.IIIA respectively. Moreover, these machines were used by SAAF and RAAF (ex-dutch machines foe Dutch East India AF) and Brazil. As a part of the Lend-Lease treaty, also Soviet Union received these machines. Based on these versions the night fighter version, US P-70 and British Havoc NF Mk.II were built. Several British machines were modified into Havoc Turbinlite equipped with searchlight in nose for night fighter missions but without success. A-20B/C proved efficient as light bombers and attack planes. USAF deployed them mainly to Africa and Italy, RAF started with Havocs the so-called Non-Stop offensive; they were used as day bombers and night Intruder missions against enemy airbases and other targets. Several machines were also deployed to Africa and Italy. Australian RAAF modified its Havocs by addition of fixed machineguns into nose and successfully used them as ground attack planes. Further development brought versions A-20G/H/J/K equipped with dorsal turret in place of the original dorsal gunner's position. These versions served until the end of the World War 2.

Wingspan: 18.69 m, length: 14.27 m, Max. Speed: 560 kmh, Range: 1,740 km, Service Ceiling: 8,800 m., Bomb load: 940 Kg; Both USAF and RAF versions differed by defensive armament.



# KIT PARTS

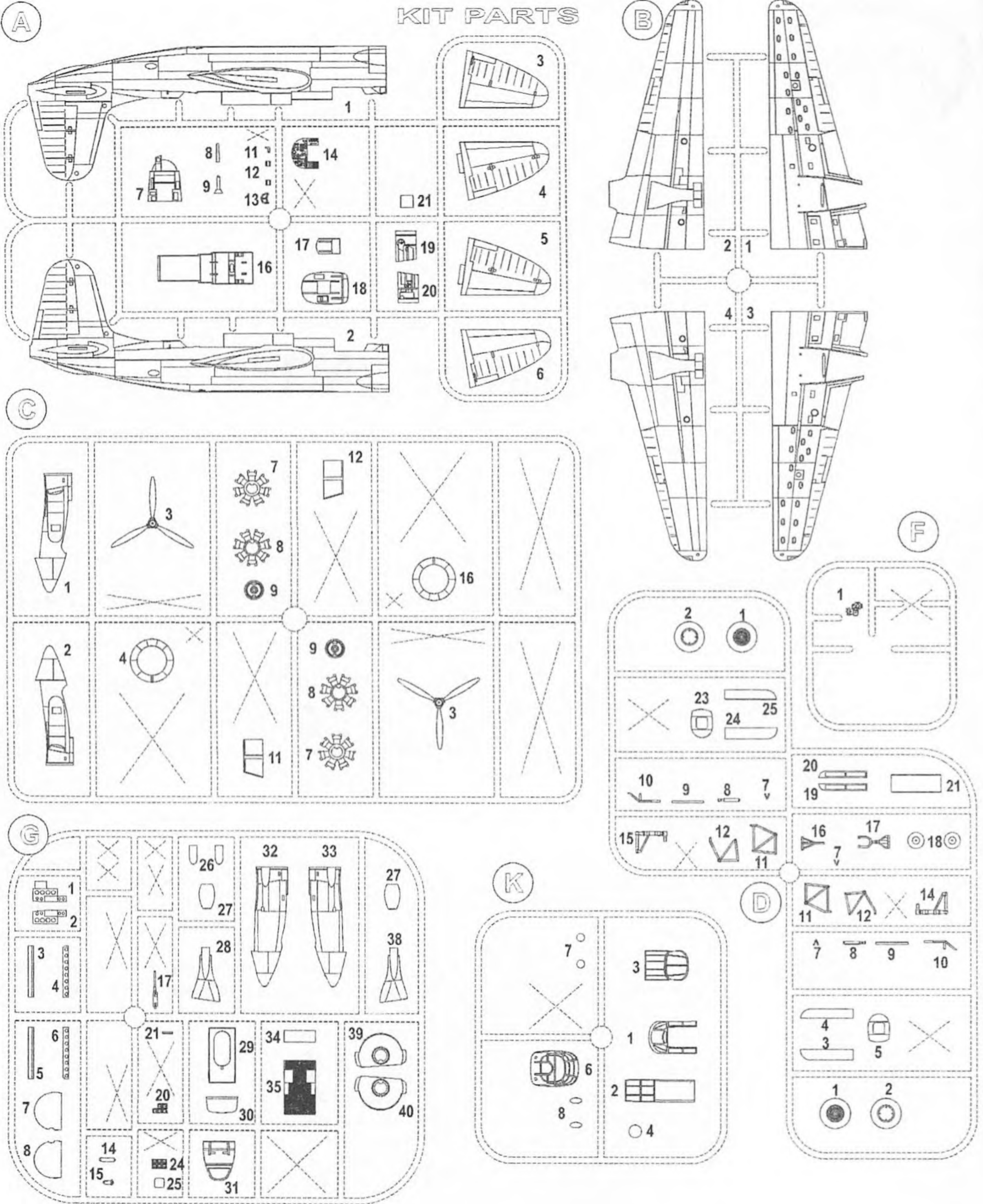

## SYMBOLS

- OPTIONAL
- WEIGHT
- CUT OFF
- SCRATCH BUILD

ASSEMBLY

STEP

1

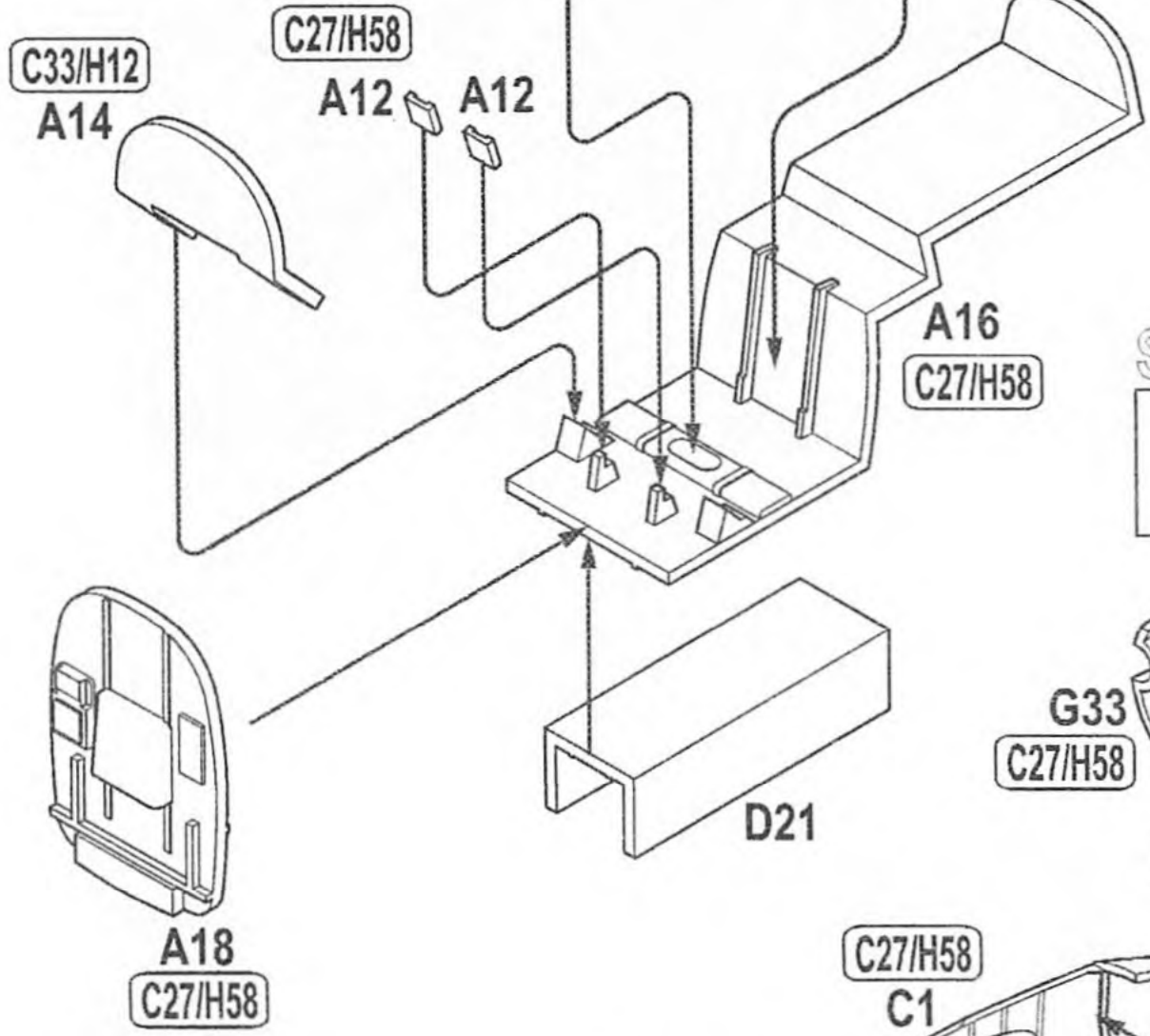

STEP

2

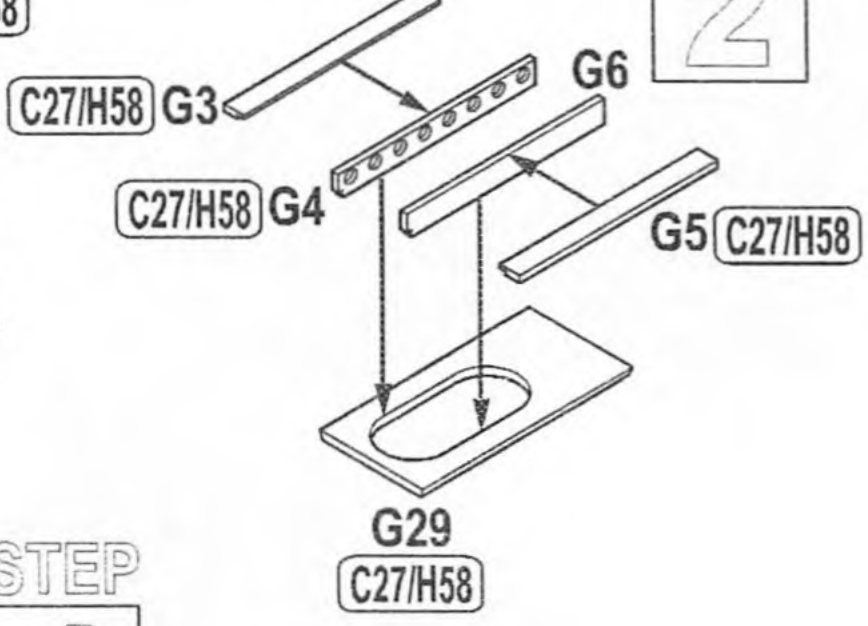

STEP

4

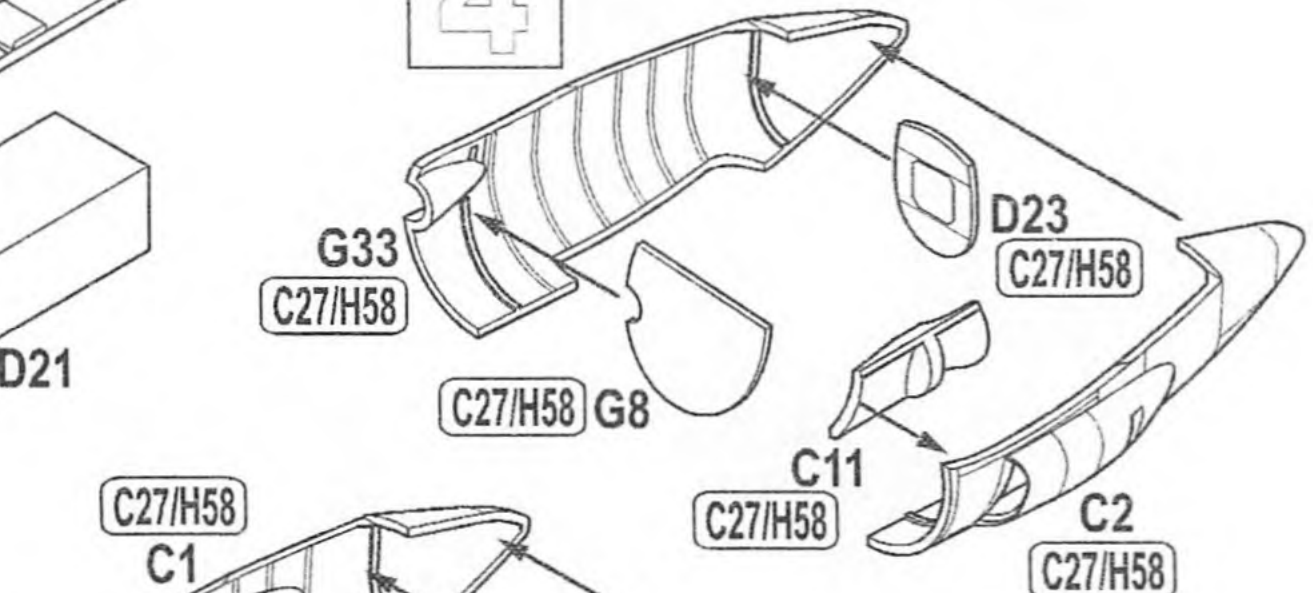

STEP

5

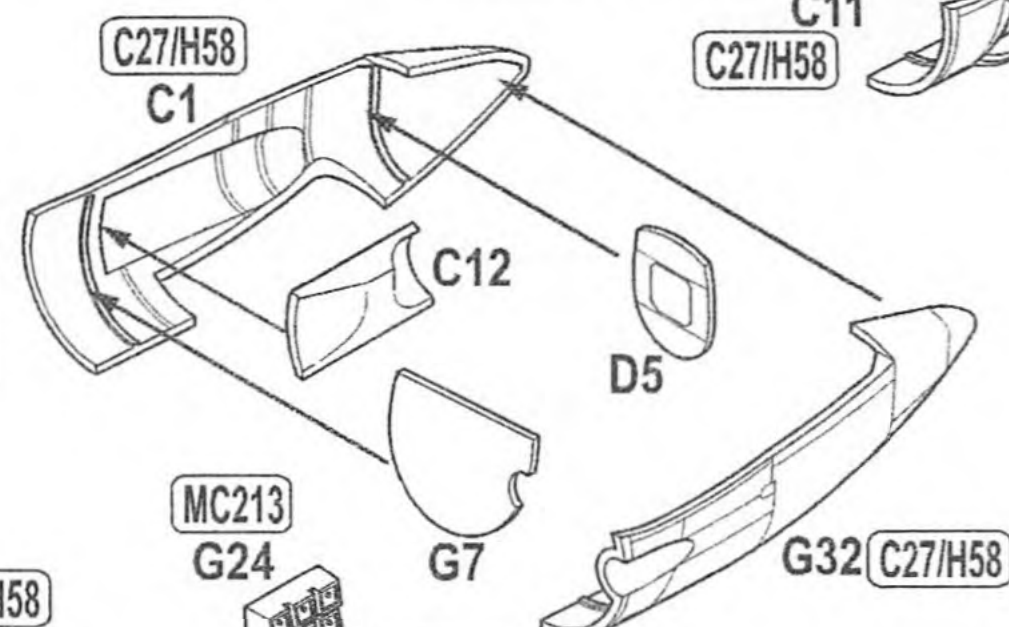

STEP

3

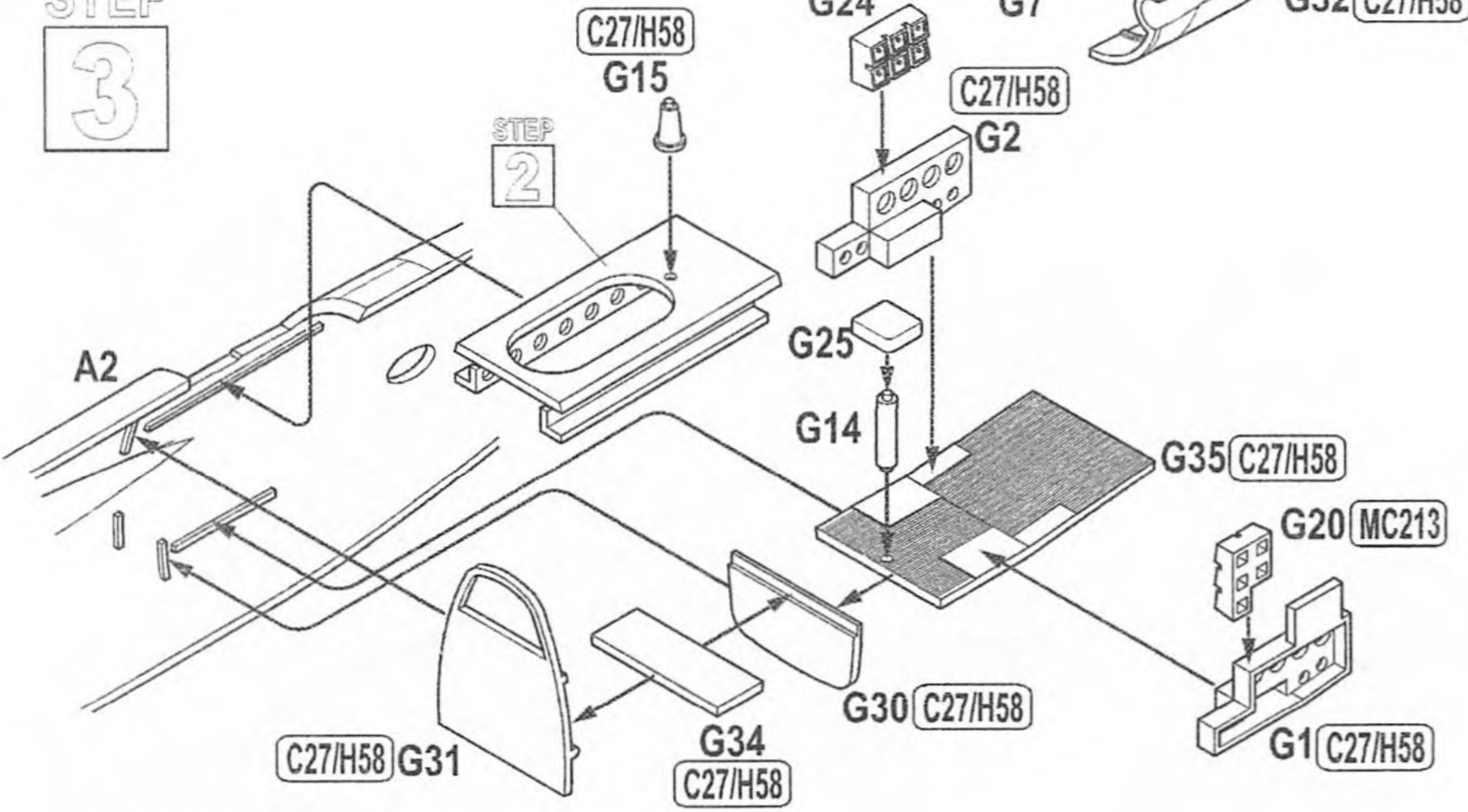



# STEP

# 6

## ASSEMBLY

Díly A19 a A20 pečlivě začistěte a vlepte tak, aby přesně zapadly do vybrání v polovinách trupu.  
 Na dílu A21 odřízněte roh dle obrázku.  
*Carefully clean parts A20 and A21 so they fit in recesses in the fuselage halves.  
 Cut the corner of part A21 according to the drawing.*

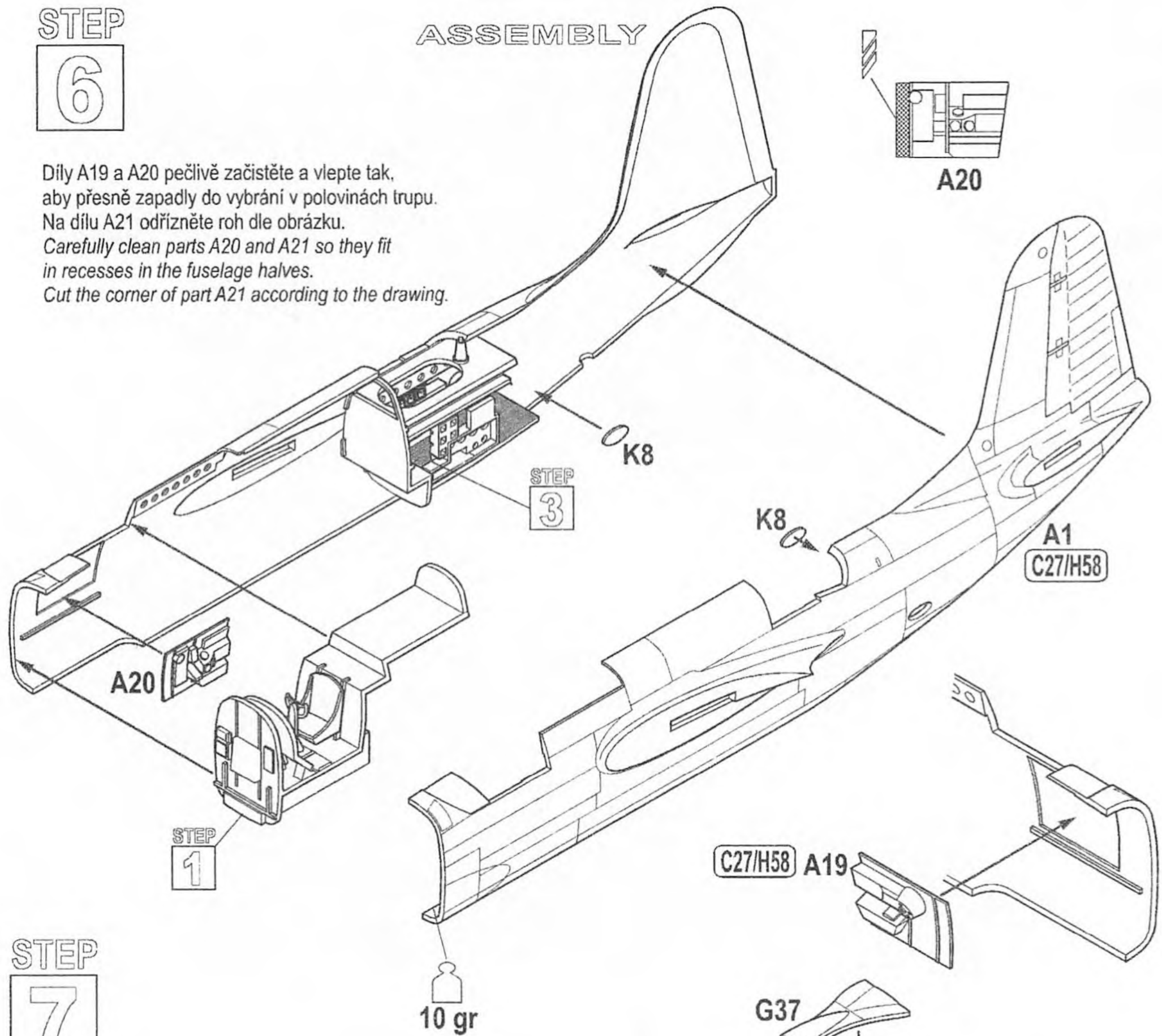

# STEP

# 7

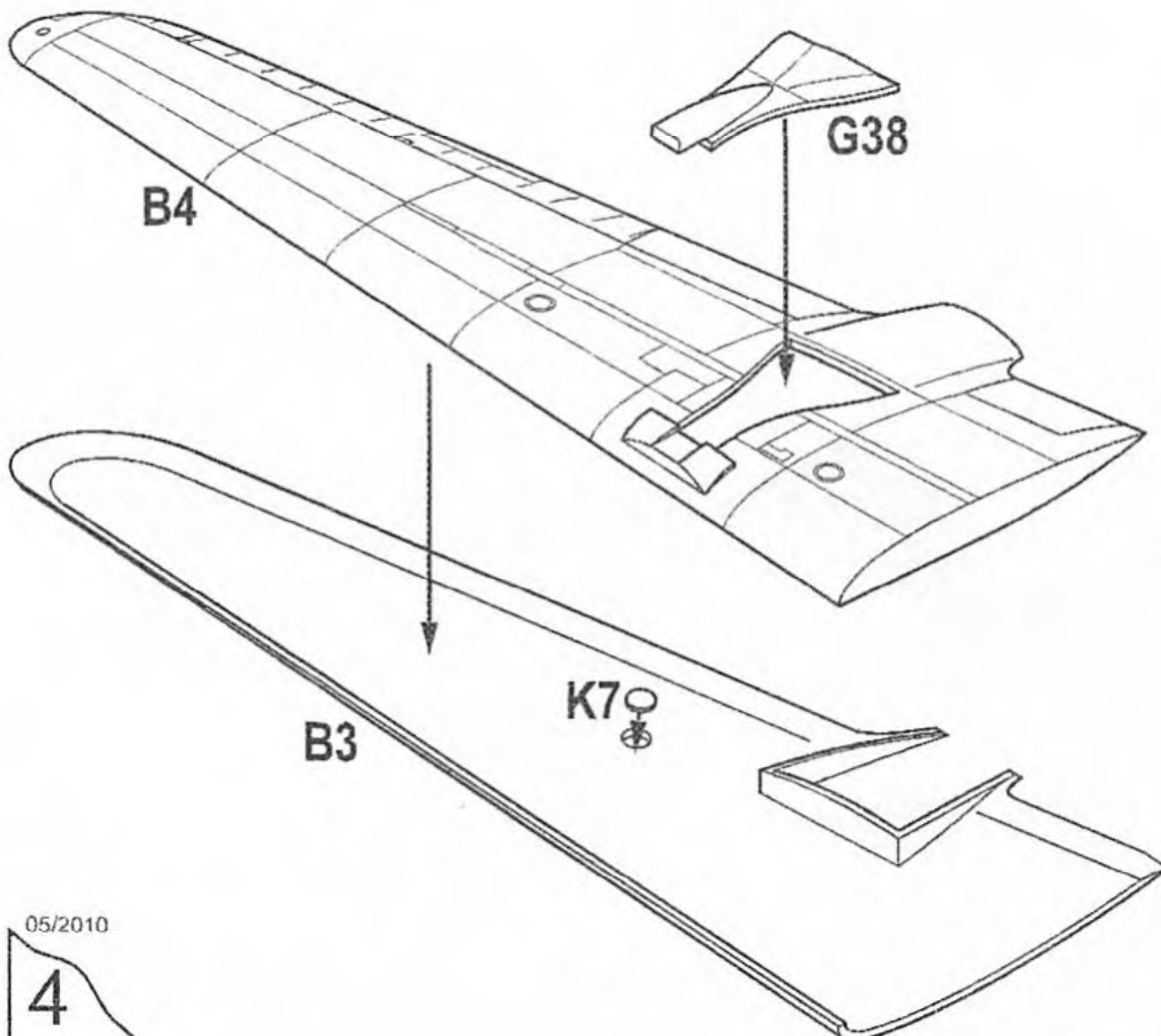

# STEP

# 8

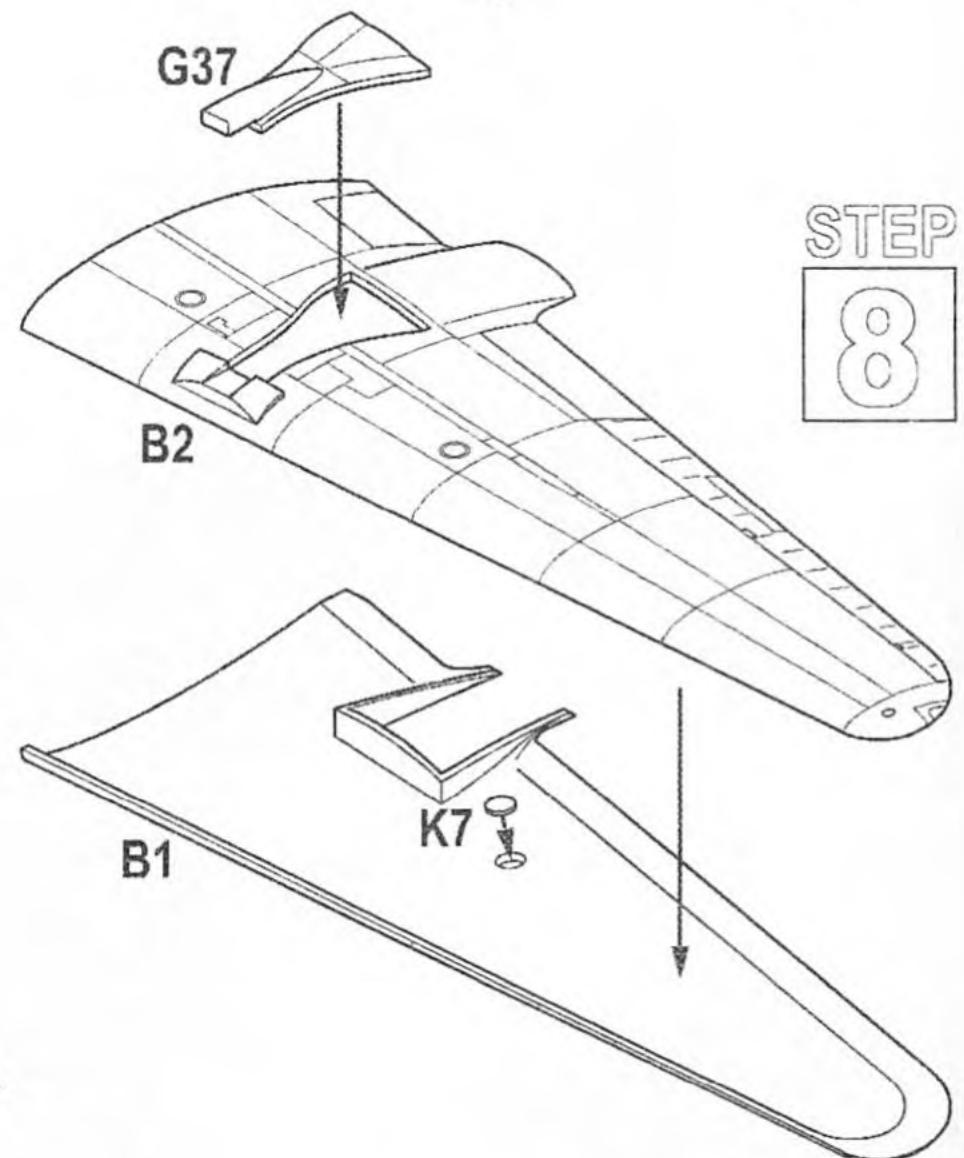

STEP  
9

ASSEMBLY

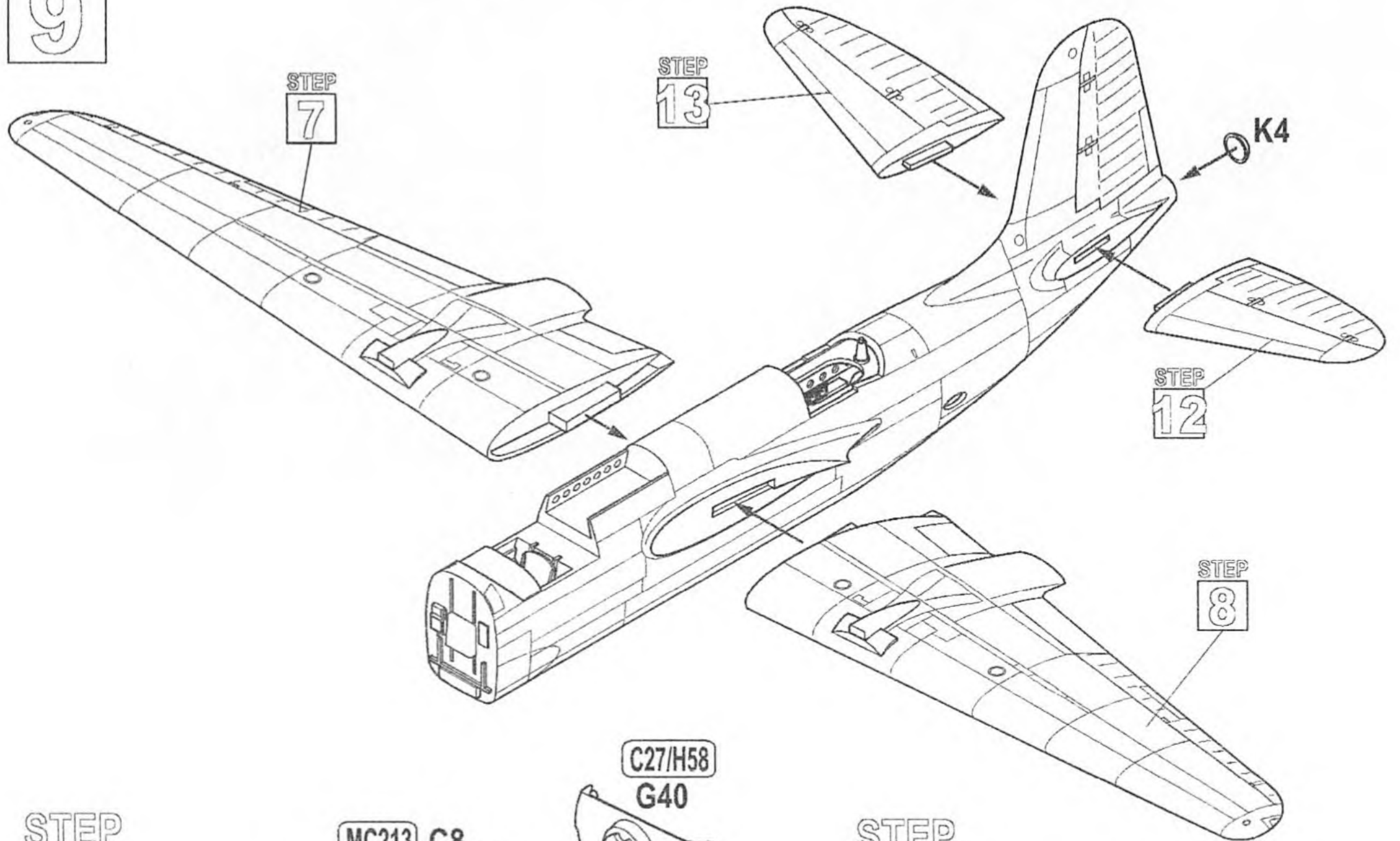

STEP  
10

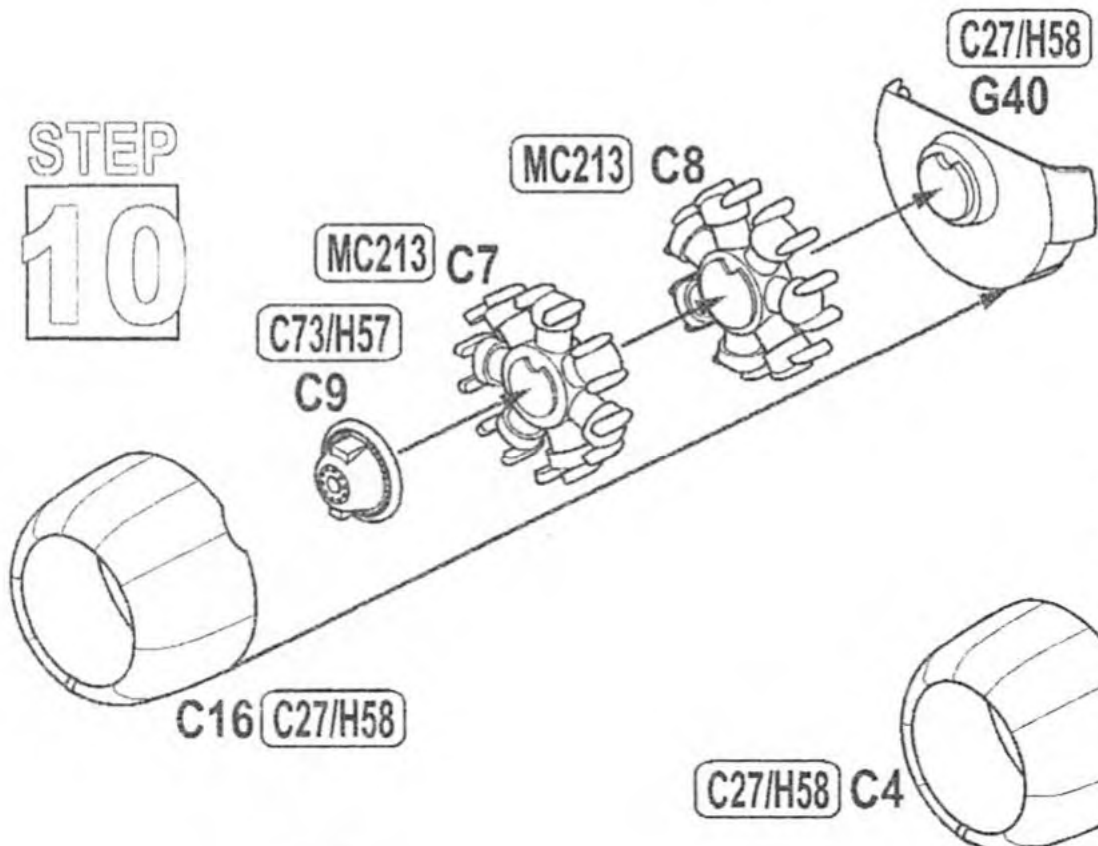

STEP  
11

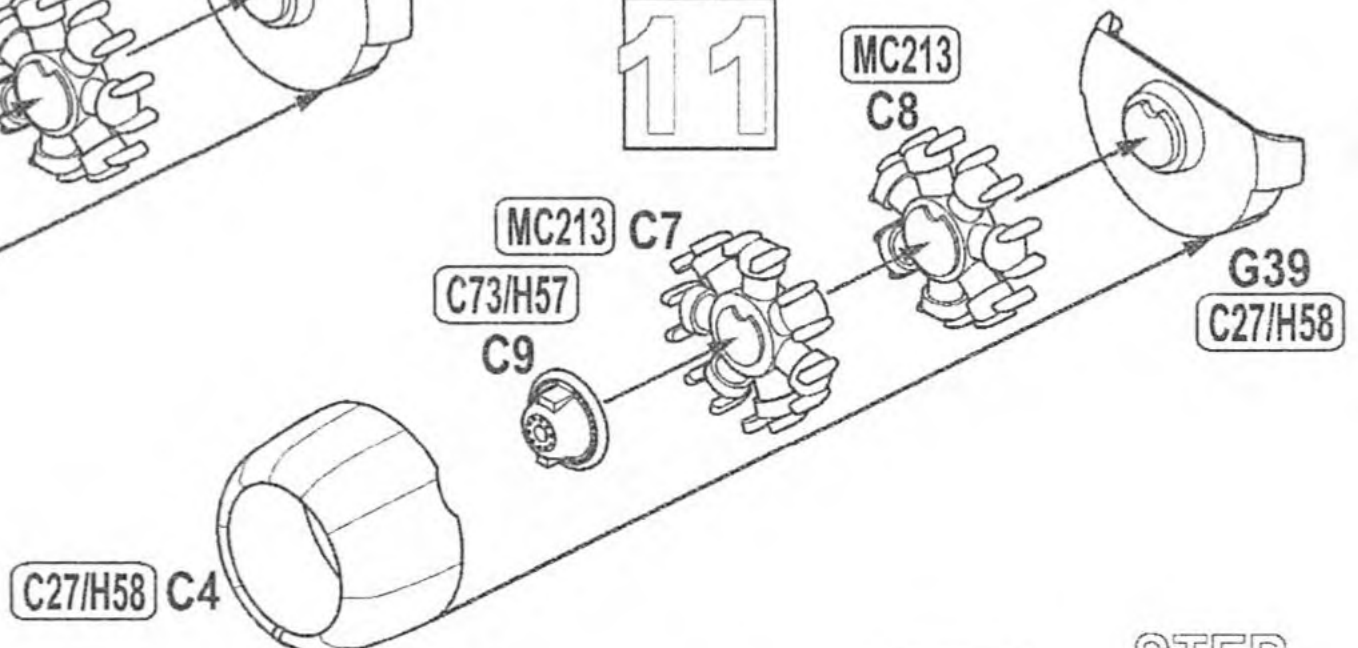

STEP  
12

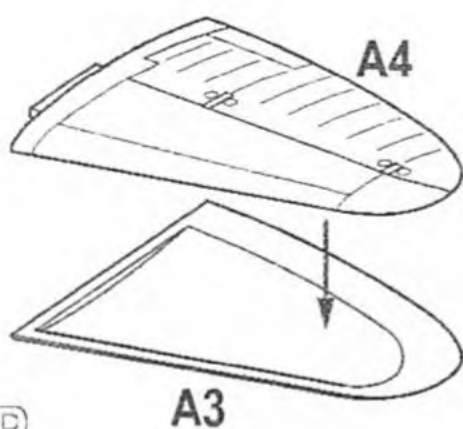

STEP  
13

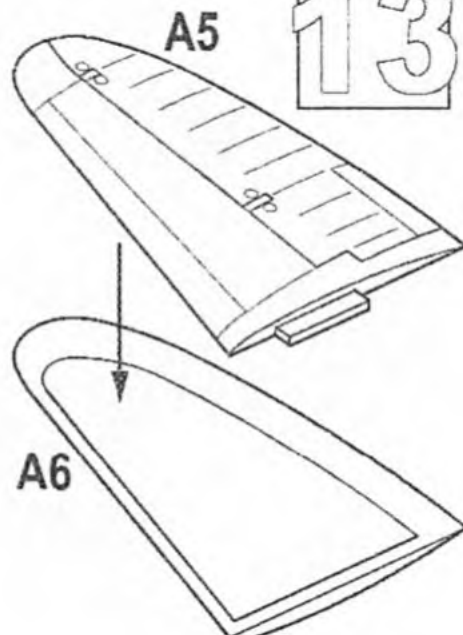

STEP  
14

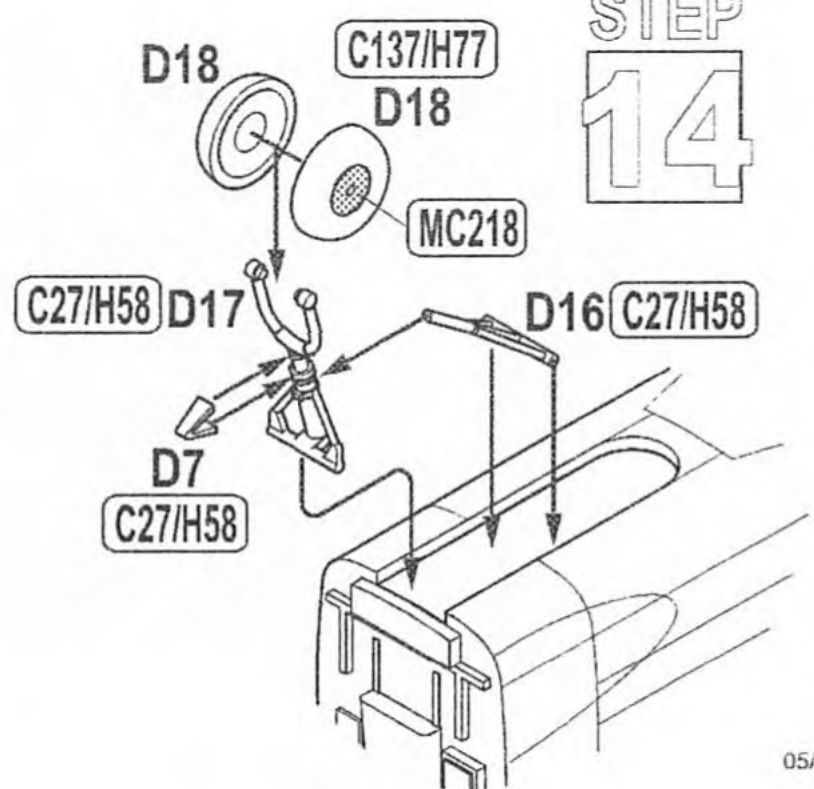



STEP  
15

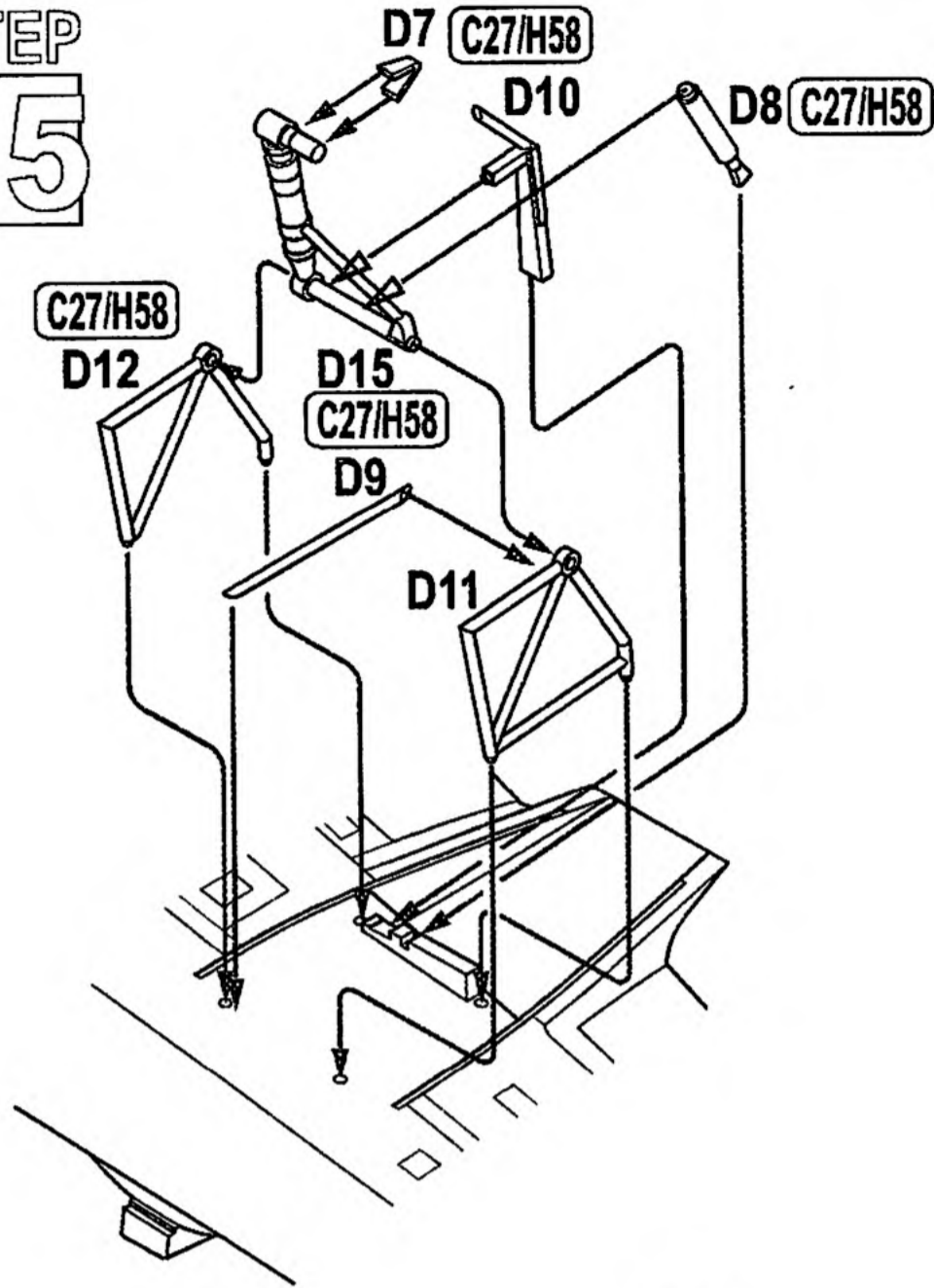

STEP  
16

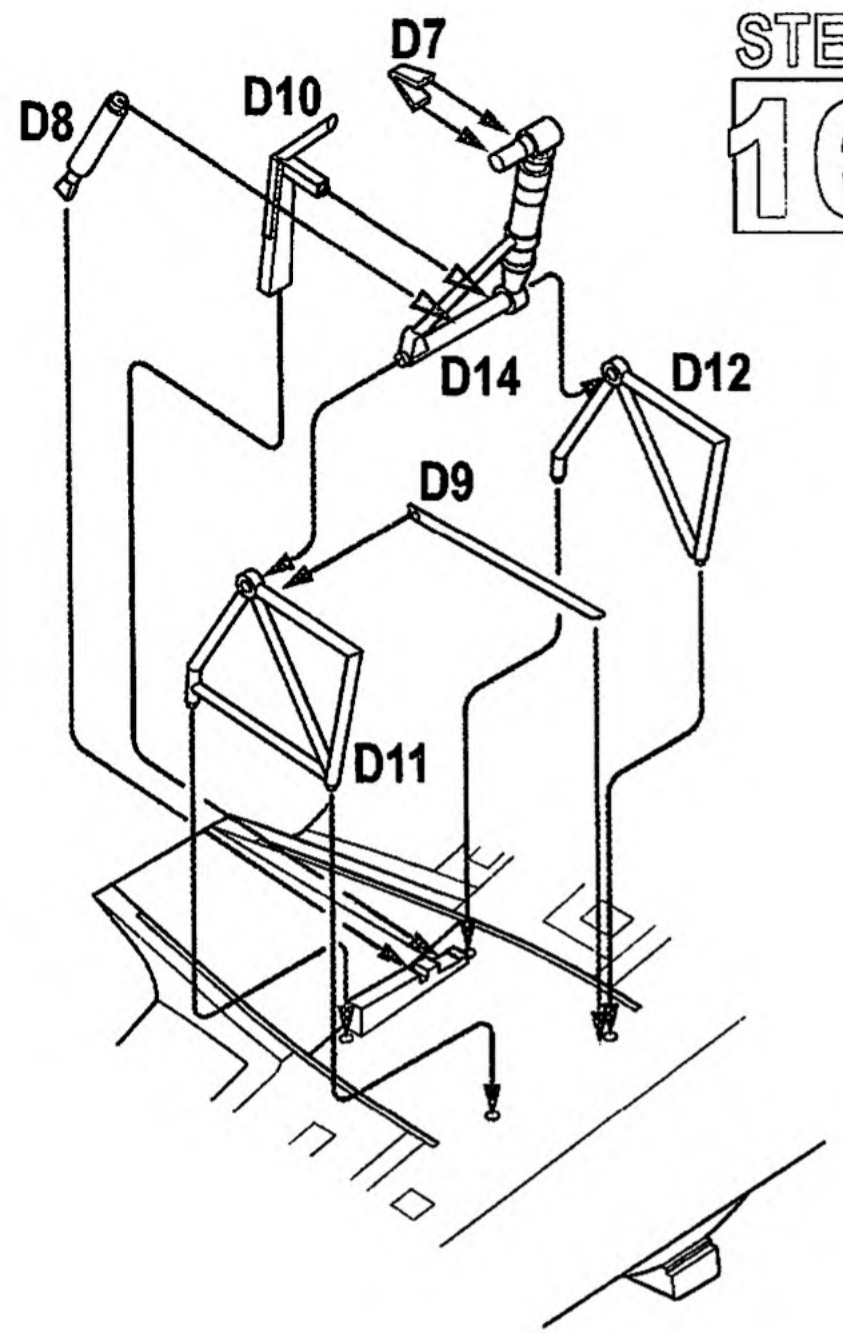

STEP  
17

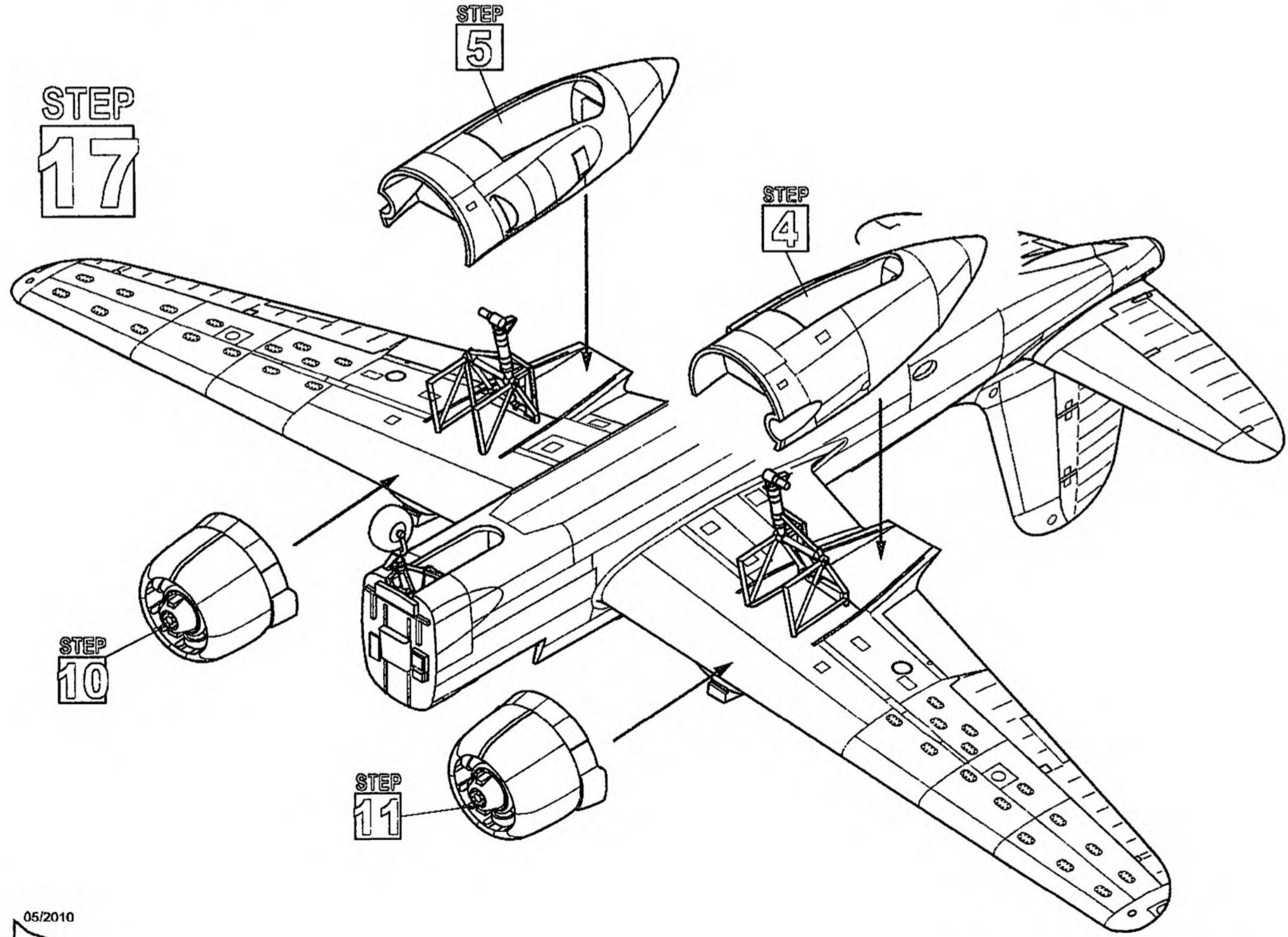

STEP  
18

ASSEMBLY

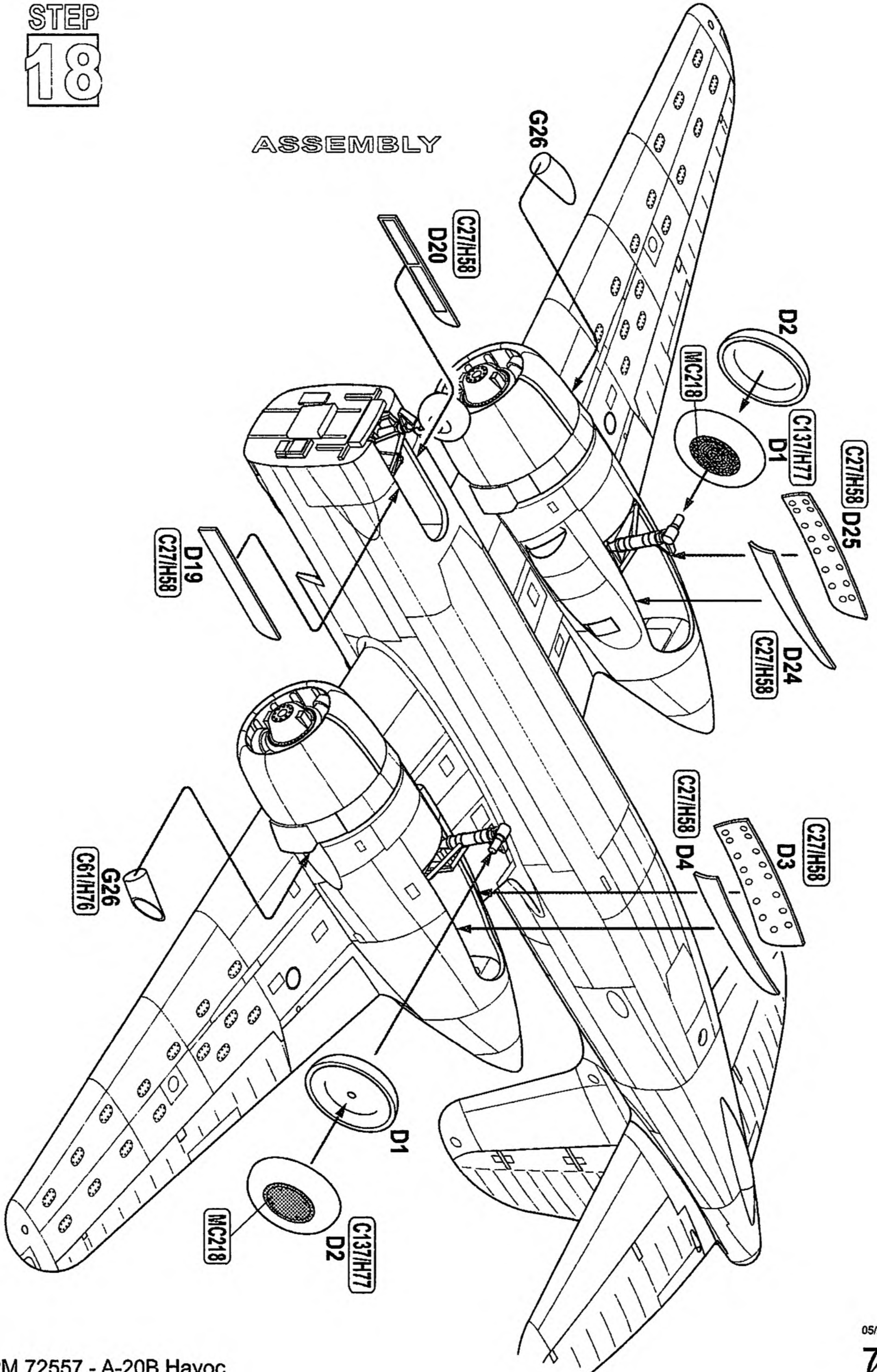

STEP  
19

ASSEMBLY

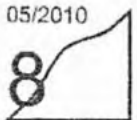
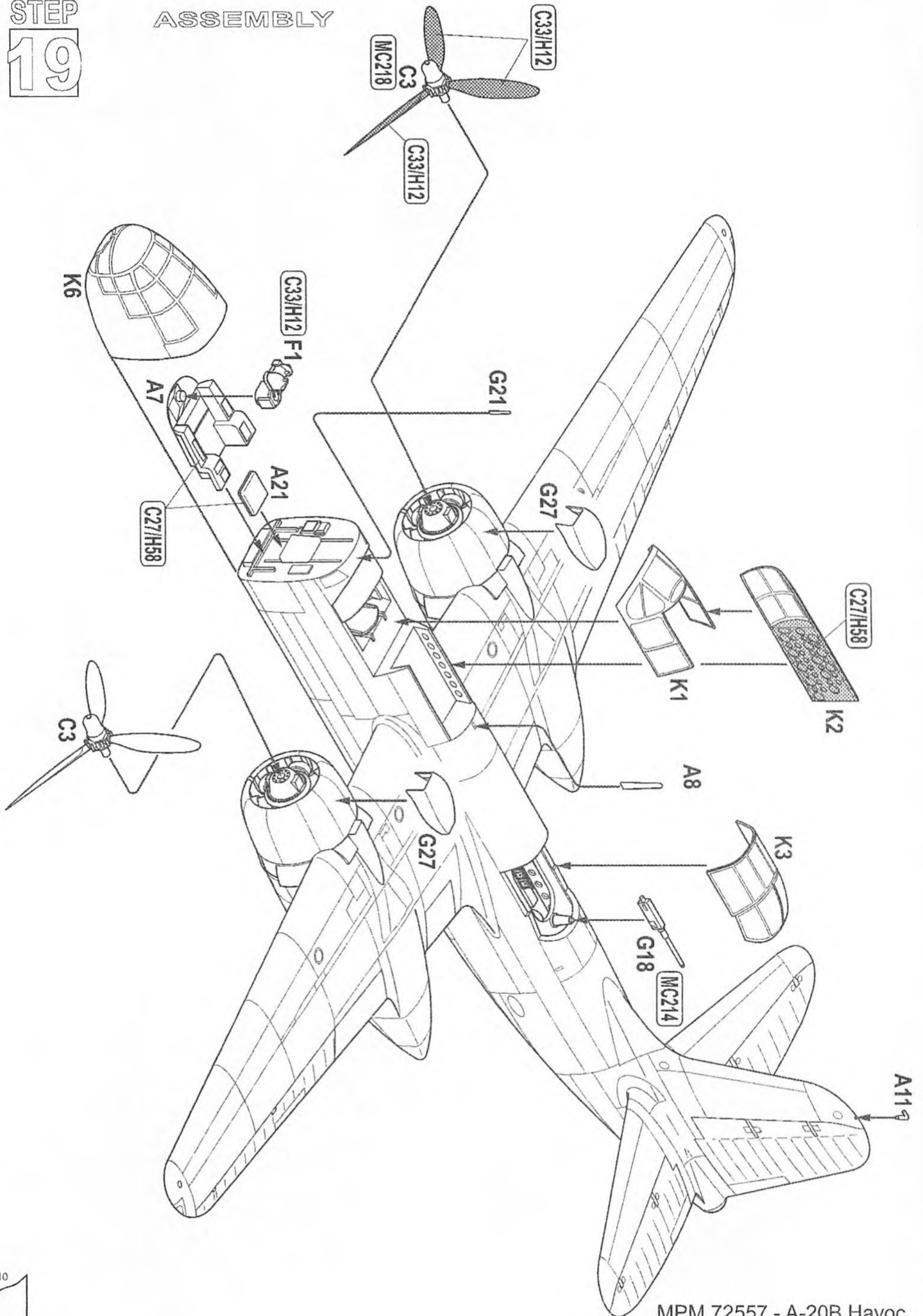



A-20B Havoc, 41-3157/17, 84. bombardovací squadrona, 47. bombardovací skupina, severní Afrika, 1943. Původní předpisová kamufláž Olive Drab/ Neutral Grey byla shora doplněna skvrnami pískové barvy. Křídélka byla v pískové barvě celá. Prosklená předl byla shora částečně zatřena, aby se bombometčík nepekl v africkém slunci.

A-20B Havoc, 41-3157/17, 84th Bomber Squadron, 47th Bomber Group, North Africa, 1943. The original standard camouflage consisting of Olive Drab/ Neutral Grey was on upper surfaces over painted by blotches of sand color. The ailerons were painted by solid layer of sand. The upper glazing of the nose was over painted to partially protect the bombardier from the African sun.

**CAM. A**

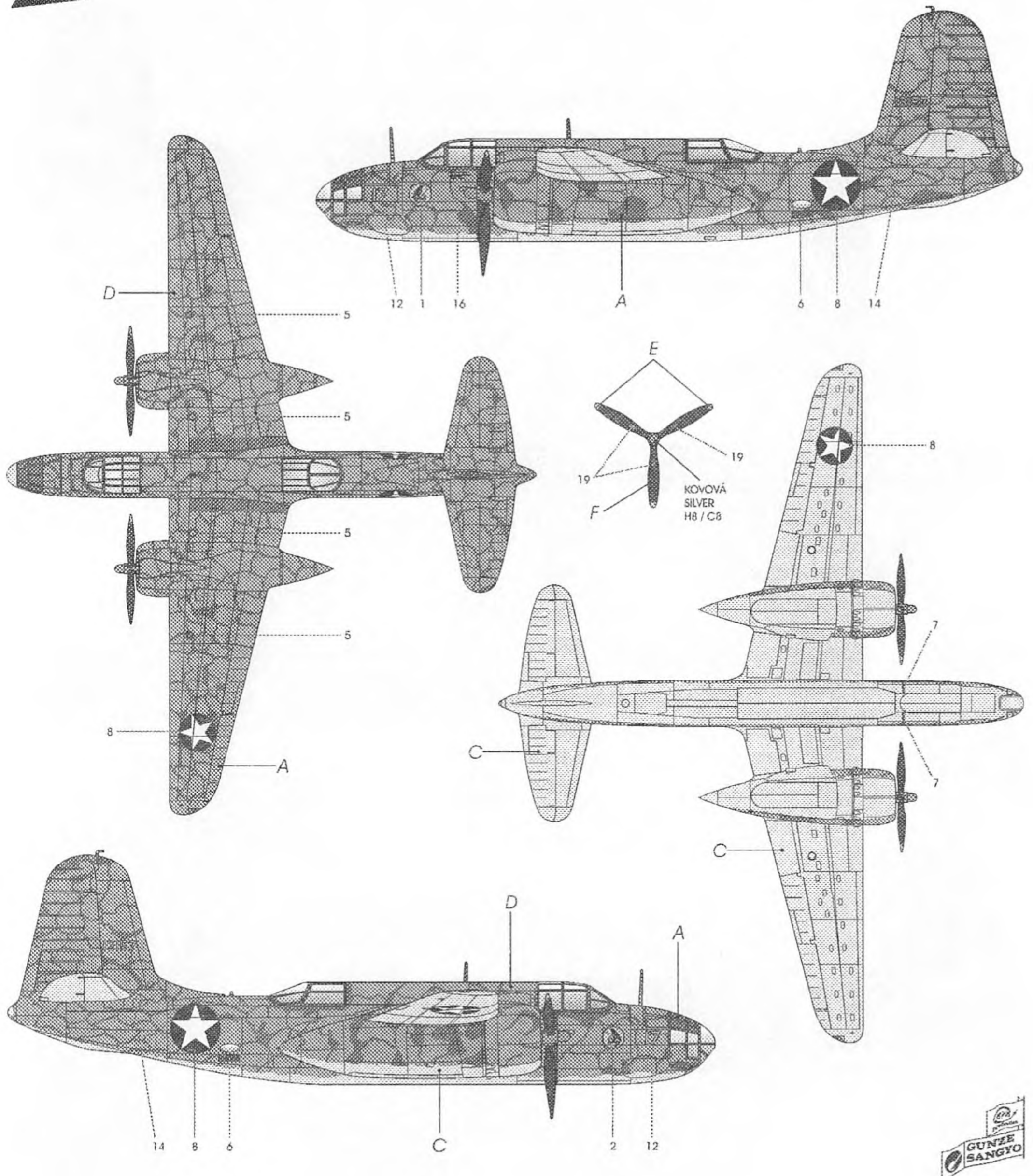

- |   |  |   |                           |                                 |   |
|---|--|---|---------------------------|---------------------------------|---|
|   |  |   |                           |                                 |   |
| A Olivová 41<br>Olive Drab 41<br>H52/ C12 | B Střední zelená 42<br>Medium Green 42<br>H302/ C302 | C Světle šedá 43<br>Neutral Grey 43<br>H53/ C13 | D Písková<br>Sand<br>C346 | E Žlutá<br>Yellow<br>H329/ C329 | F Matná Černá<br>Flat Black<br>H12/ C33 |

A-20B Havoc, 41-3117, „Lady Jean“, 47. bombardovací skupina, Alžír, severní Afrika, prosinec 1942. Předpisová kamufláž a označení byly na ocasních plochách a křídlech doplněny o americké vlajky. V prosinci 1942 „Lady Jean“ nouzově přistála mimo letiště. Poslední den tohoto roku z ní bylo vymontováno použitelné vybavení a byla ponechána svému osudu.

A-20B Havoc, 41-3117, „Lady Jean“, 47th Bomber Group, Algeria, North Africa, December 1942. The standard camouflage and markings were enhanced by the addition of US national flags on the tail fin and wings. Lady Jean emergency landed out of the airfield in December 1942. At the last day of the year the aircraft was stripped off all usable equipment and left to its fate.

**CAM. B**

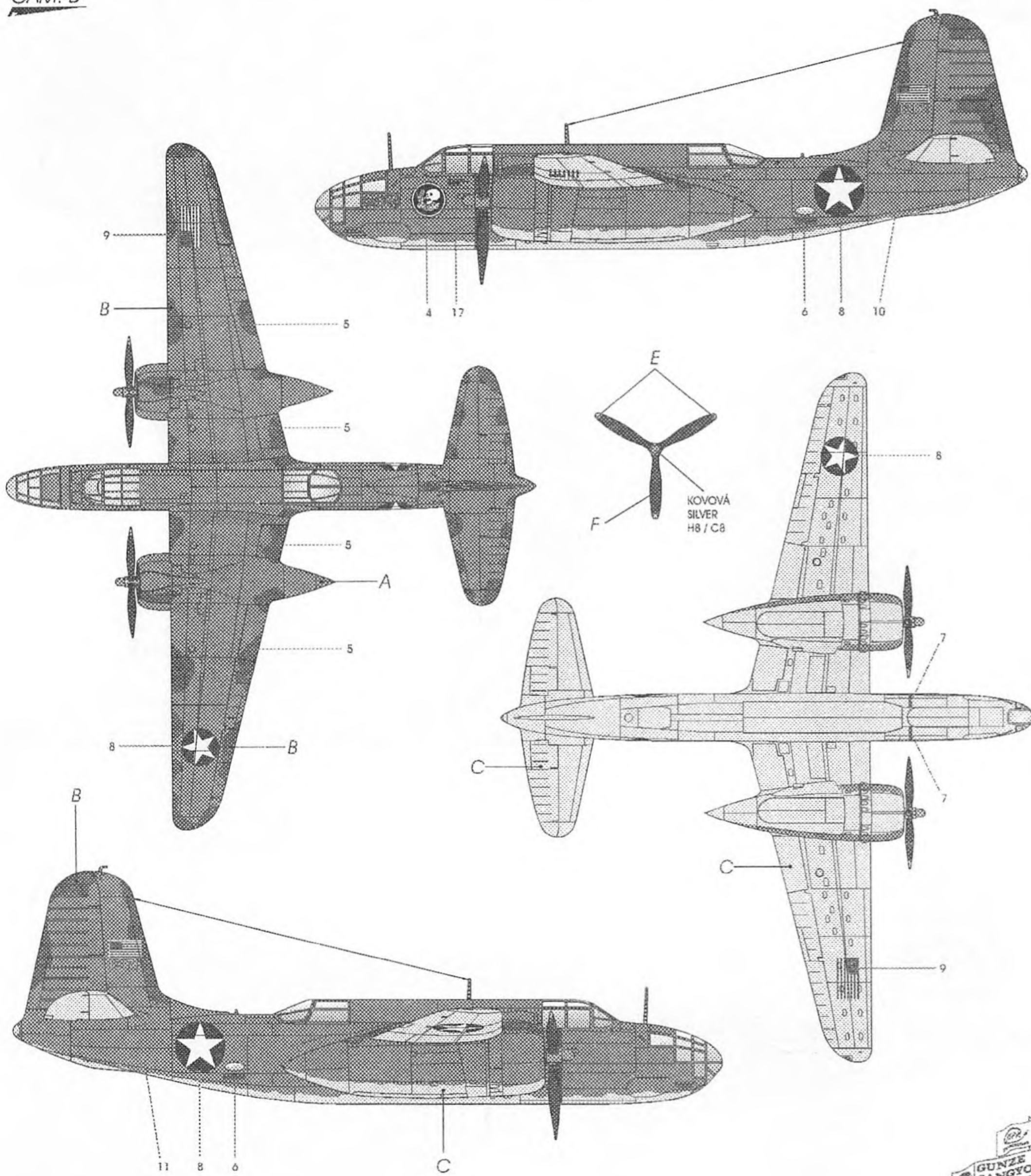

- |          |   |          |  |          |   |          |                         |          |                               |          |                                       |
|----------|---|----------|--|----------|---|----------|-------------------------|----------|-------------------------------|----------|---------------------------------------|
| <b>A</b> | Olivová 41<br>Olive Drab 41<br>H52/ C12 | <b>B</b> | Střední zelená 42<br>Medium Green 42<br>H302/ C302 | <b>C</b> | Světle šedá 43<br>Neutral Grey 43<br>H53/ C13 | <b>D</b> | Písková<br>Sand<br>C346 | <b>E</b> | Žlutá<br>Yellow<br>H329/ C329 | <b>F</b> | Matná Černá<br>Flat Black<br>H12/ C33 |
|----------|---|----------|--|----------|---|----------|-------------------------|----------|-------------------------------|----------|---------------------------------------|





A-20B Havoc, 41-3148/34, „Miss Burma“, 86. bombardovací squadrona, 47. bombardovací skupina, Itálie, 1943. Veterán 47. bombardovací skupiny měl celkový počet náletů uveden na levém boku pod kabinou. Opořebení povrchu odpovídalo dlouhé službě stroje v prašném prostředí.

A-20B Havoc, 41-3148/34, „Miss Burma“, 86th Bomber Squadron, 47th Bomber Group, Italy, 1943. Veteran of 47th BG sported the mission log painted in shape of the bombs on starboard side below the canopy. The weathering corresponded with the long service in harsh and dusty conditions.

CAM. C

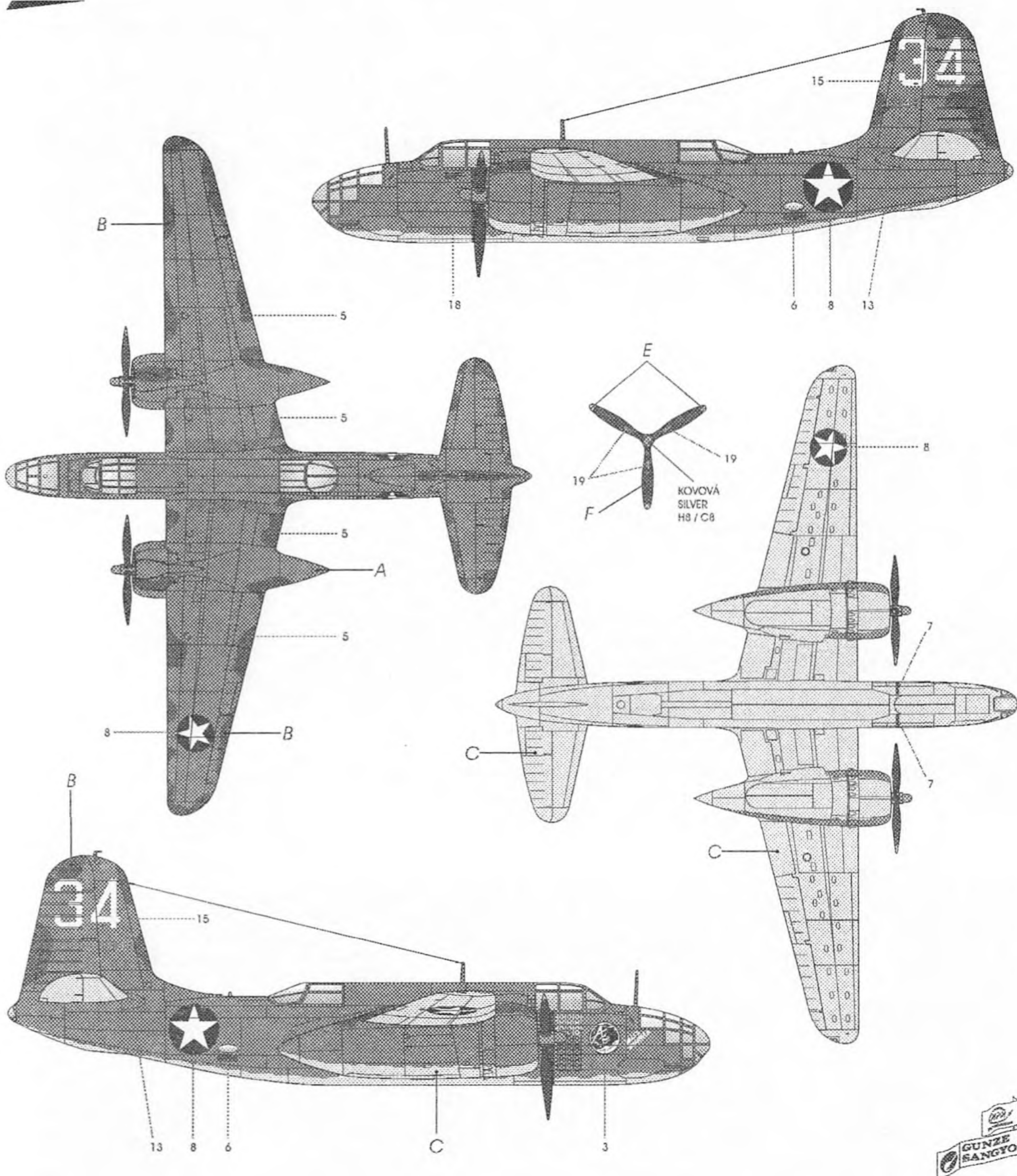

- |   |  |   |                         |                               |                                       |
|---|--|---|-------------------------|-------------------------------|---------------------------------------|
| <b>A</b>                                | <b>B</b>   | <b>C</b>                                      | <b>D</b>                | <b>E</b>                      | <b>F</b>                              |
| Olivová 41<br>Olive Drab 41<br>H52/ C12 | Střední zelená 42<br>Medium Green 42<br>H302/ C302 | Světle šedá 43<br>Neutral Grey 43<br>H53/ C13 | Písková<br>Sand<br>C346 | Žlutá<br>Yellow<br>H329/ C329 | Matná Černá<br>Flat Black<br>H12/ C33 |

72557 Douglas A-20B/C Havoc "MTO"

**Special HOBBY**

**limited run plastic kits**

High quality injected plastic kits - short run/ Vstříkované modely - limitovaná série

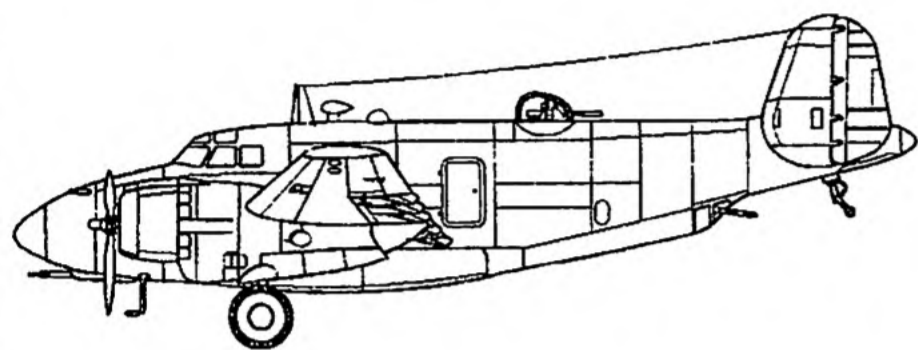

SH72093 PV-2 Harpoon U. S. NAVY

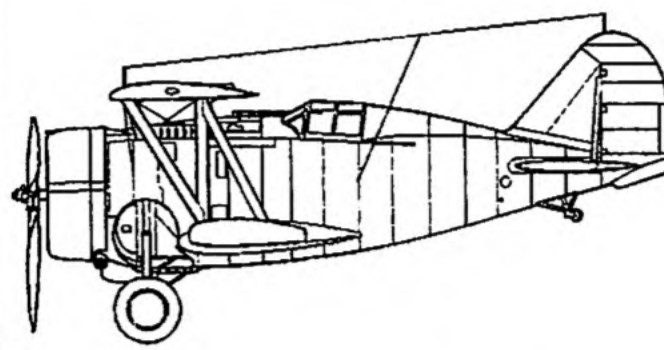

1/72 SH72106 F3F-2 "Flying Barrel"

1/72

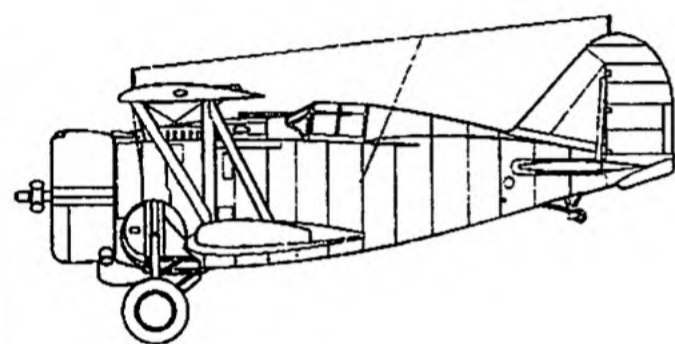

SH72109 F3F-2 "Last U.S. NAVY Biplane Fighter" 1/72

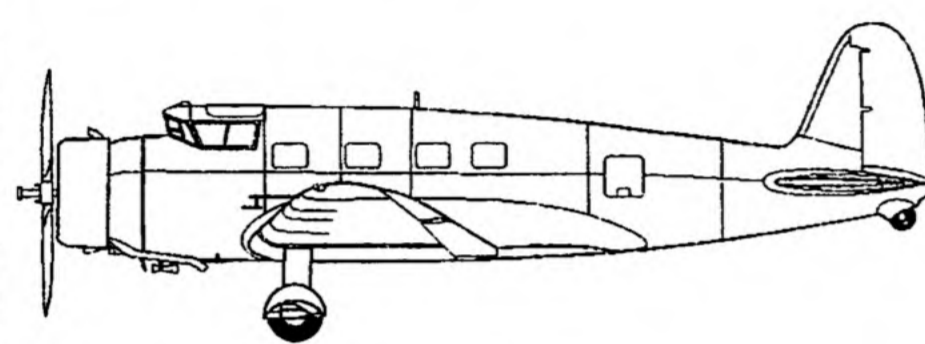

SH72130 Vultee V-1a "Cvillian Version"

1/72

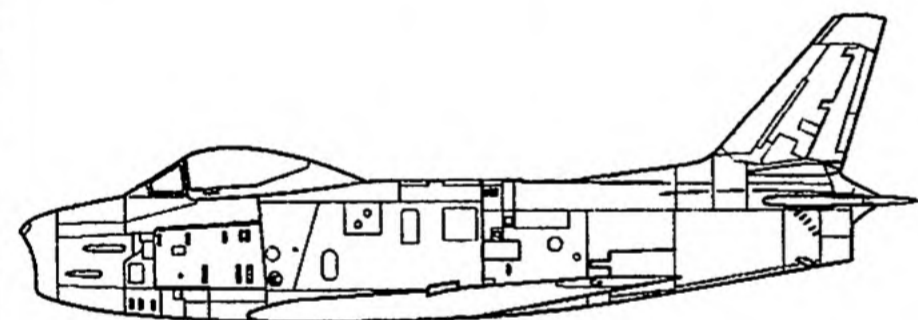

SH72120 F-86H Sabre Hog

1/72

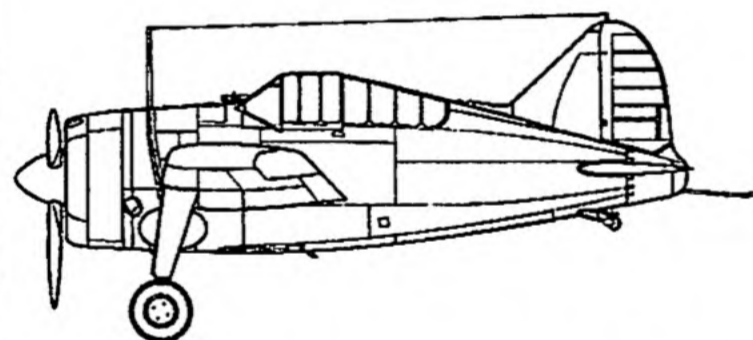

SH72133 F2A-2 Buffalo "Yellow Wing"

1/72

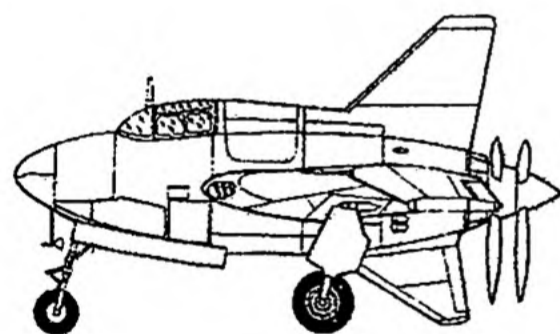

SH72132 Northrop XP-56 II

1/72

*Hi-tech version*

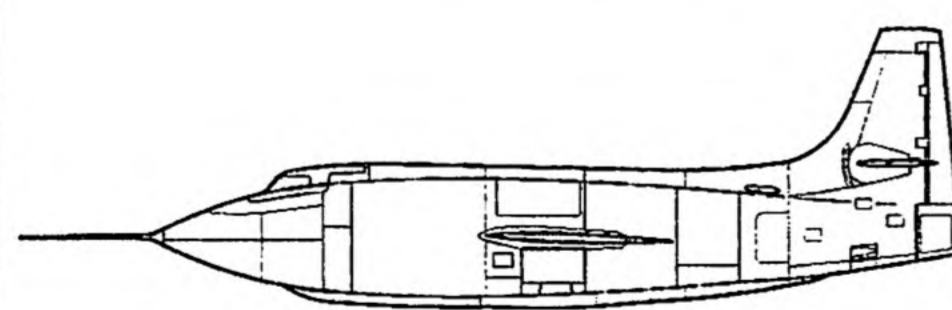

SH72158 X-1E "Last Model"

1/72

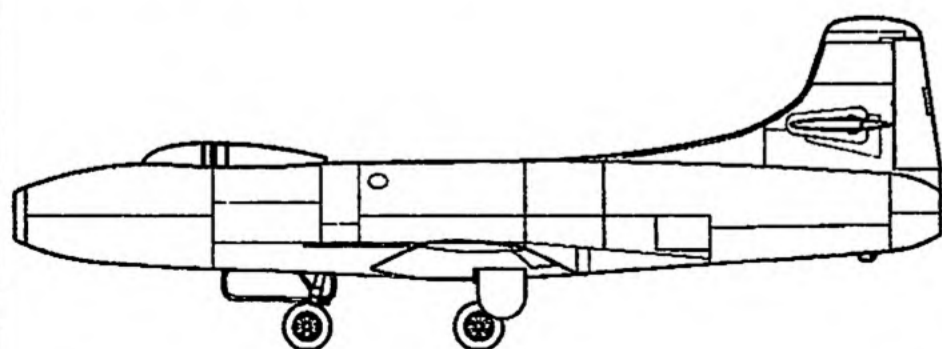

SH72159 D-558-1 Skystreak

1/72

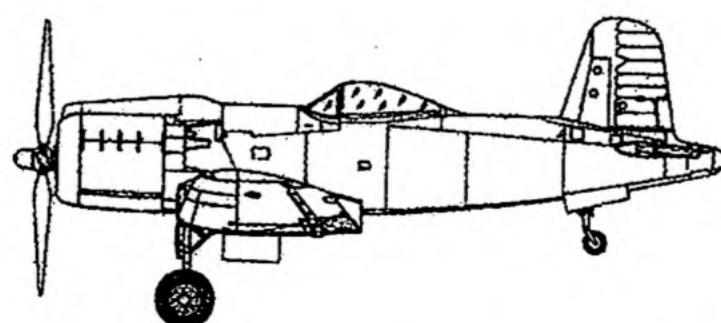

SH72166 F2G-1/2 Super Corsair Racer

1/72

