

Kit Résine
35004
Resin Kit

MASTERS
Productions

CONVERSION GMC 40 mm BOFORS

Echelle : 1/35

Made in France

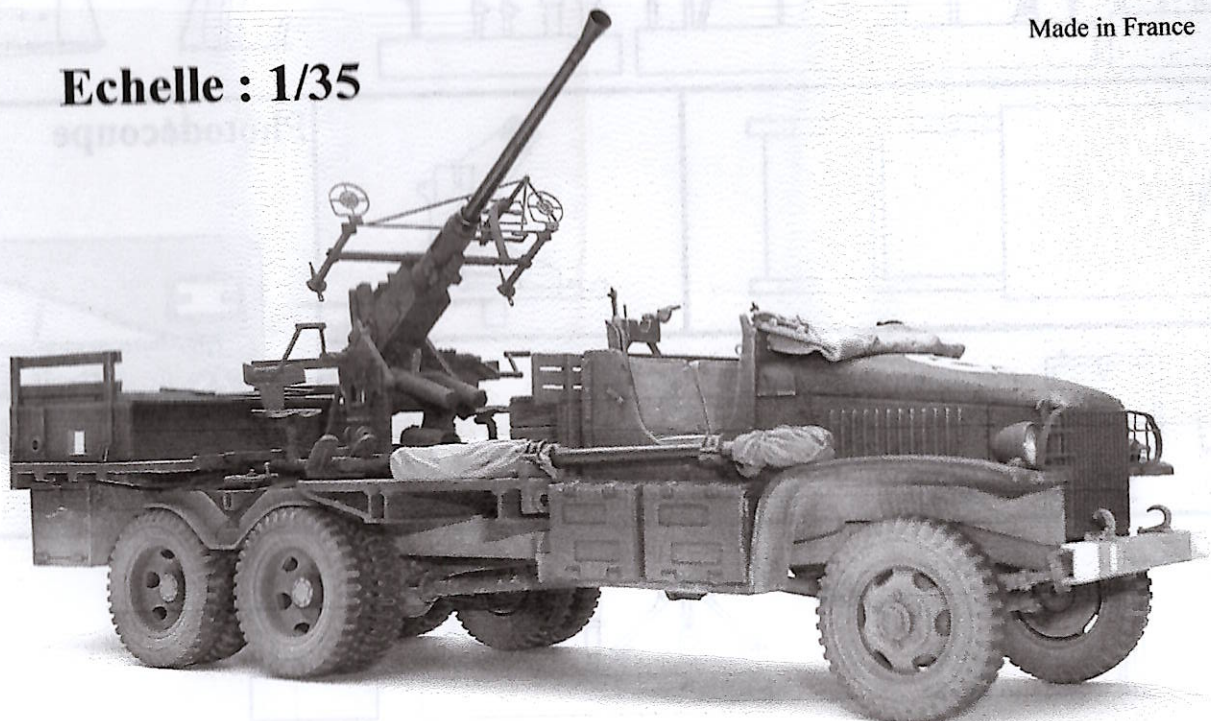

SARL au capital de 7625 Euros
Siège social : 107 rue de Joigny 89300 CHAMVRES Tél : 03.86.91.09.25 Email : mastersproductions@libertysurf.fr

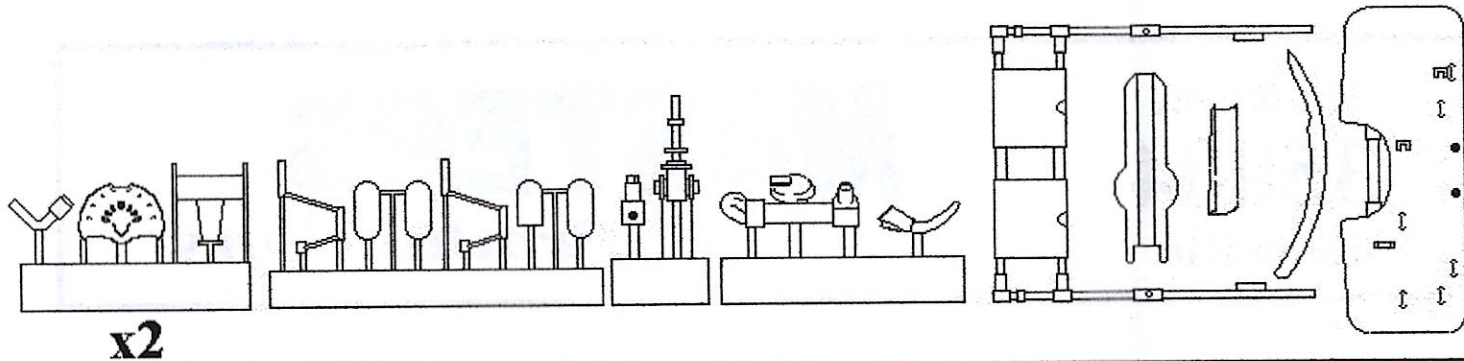

x2

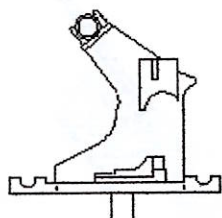
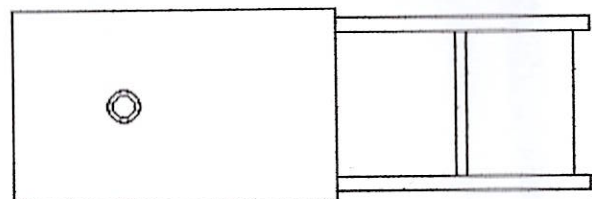
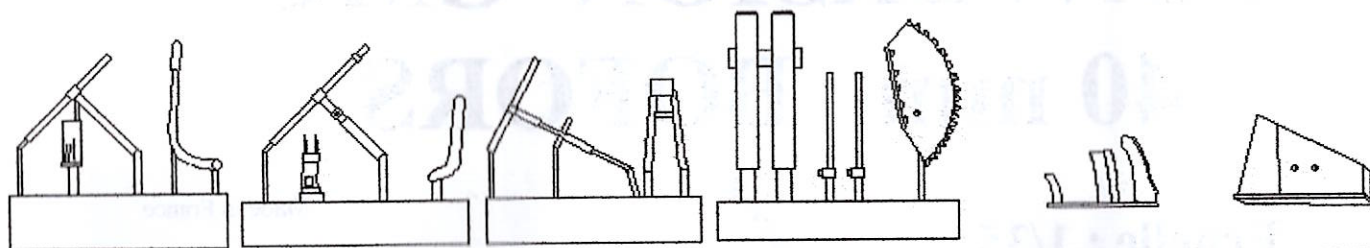
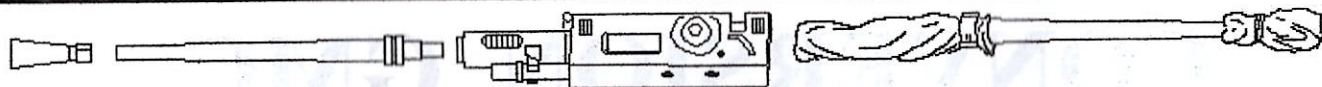

Photodécoupe

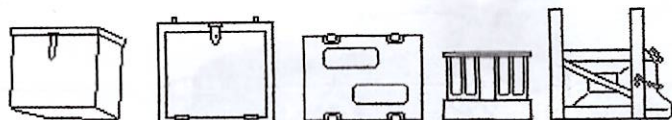
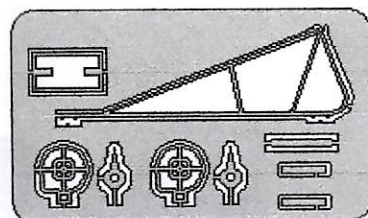

x2

x3

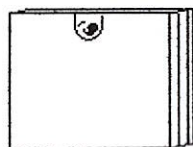

x2

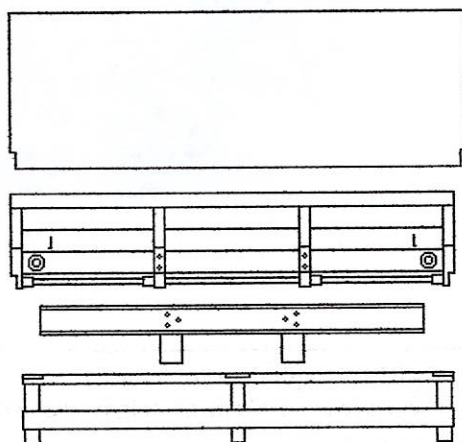
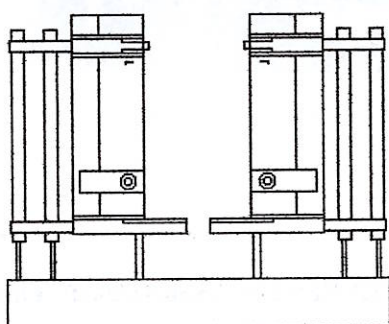
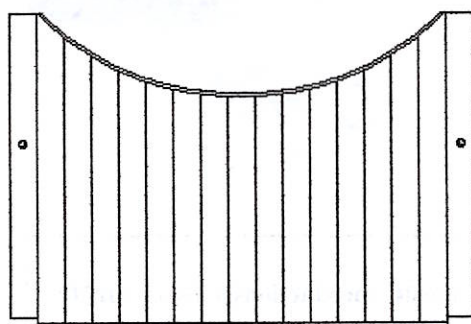
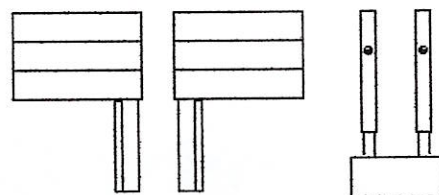
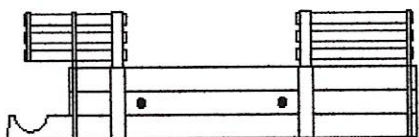
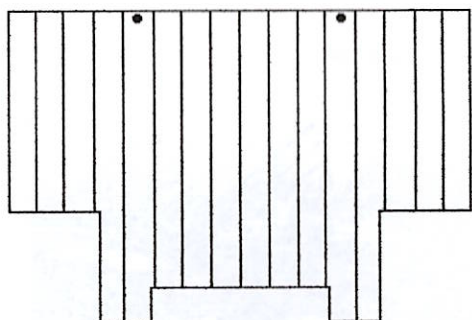
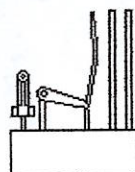
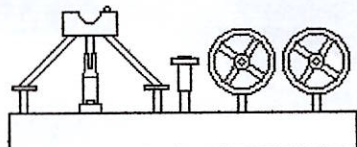

Adaptations sur châssis TAMIYA et ITALERI

Les pièces sont prévues pour le châssis TAMIYA

Supprimer les parties hachurées pour l'adaptation sur châssis ITALERI

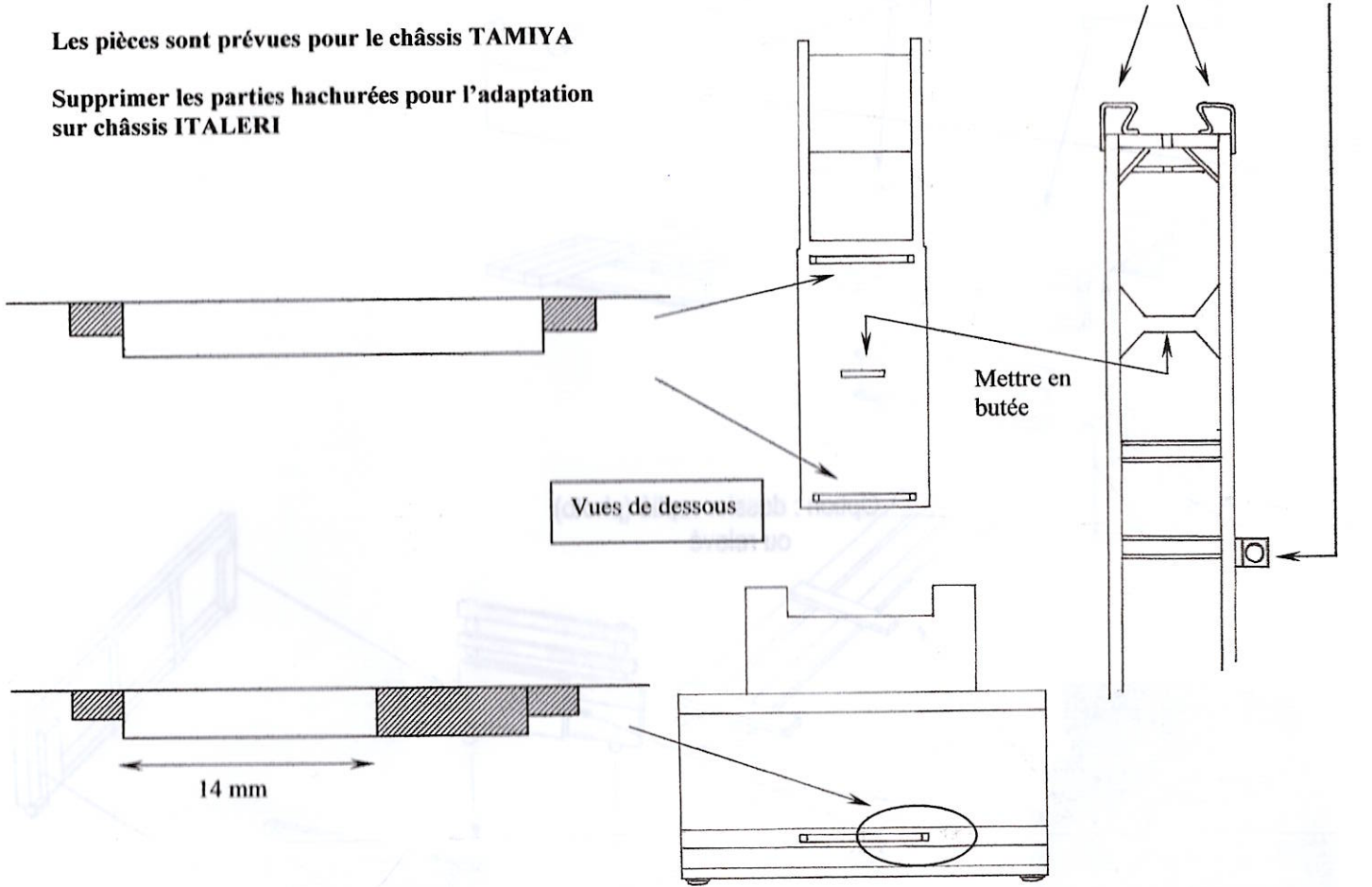

Pour la maquette TAMIYA Mécanisme de direction

Emplacement de la roue de secours

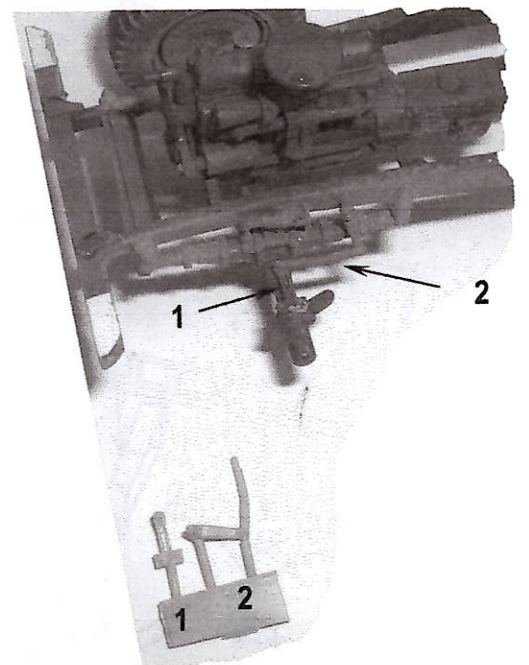
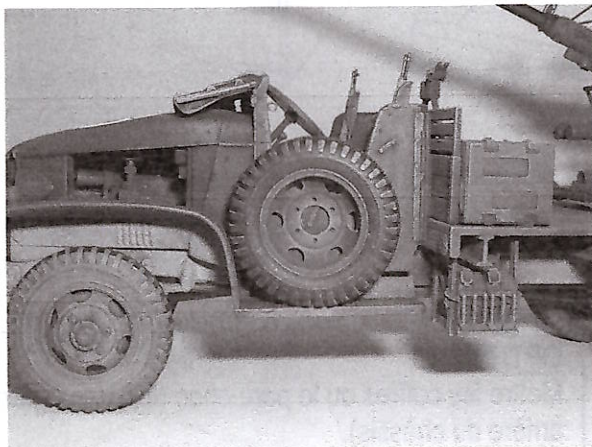

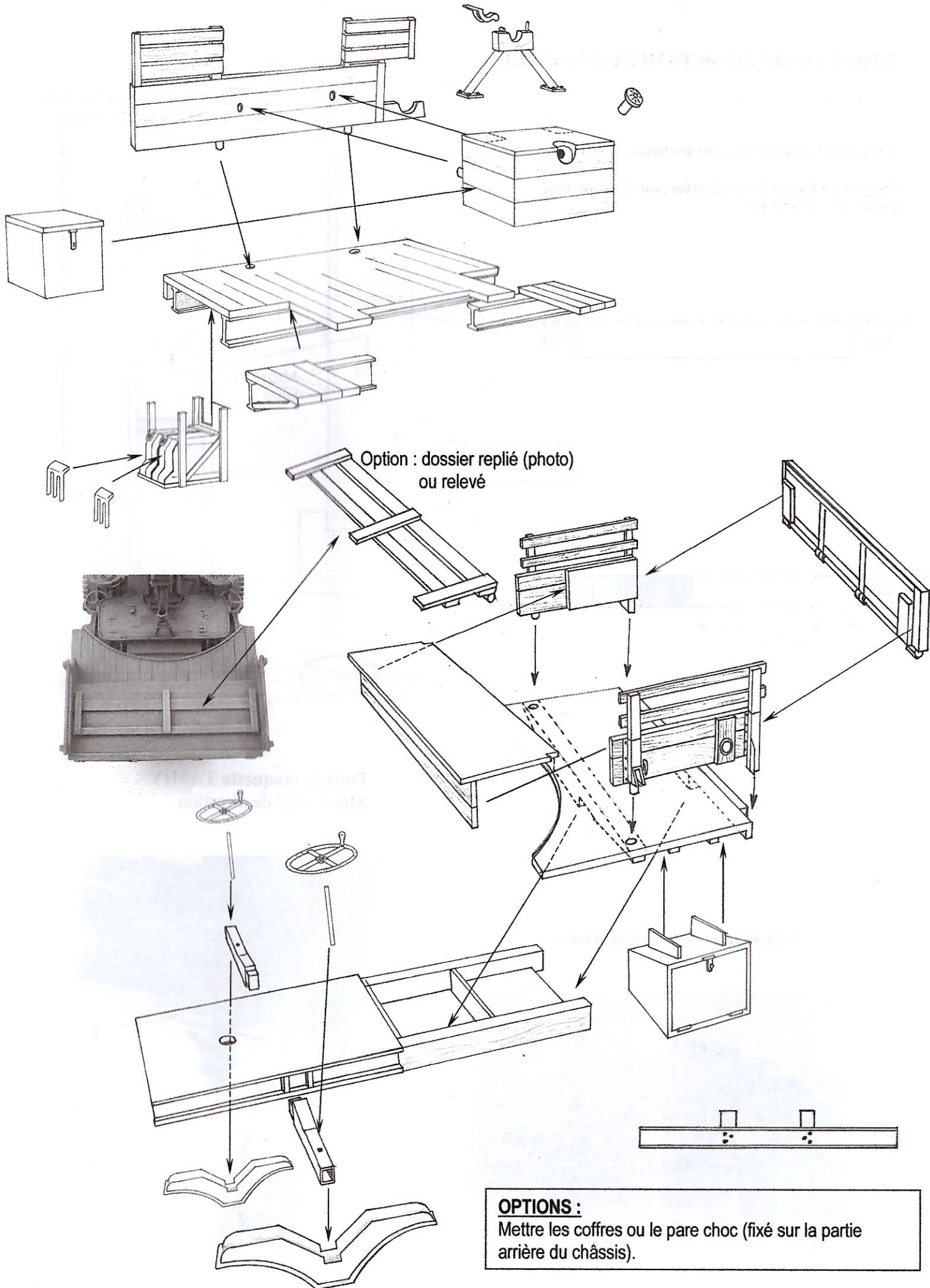

Option : dossier replié (photo)
ou relevé

OPTIONS :

Mettre les coffres ou le pare choc (fixé sur la partie
arrière du châssis).

Montage du système de visée

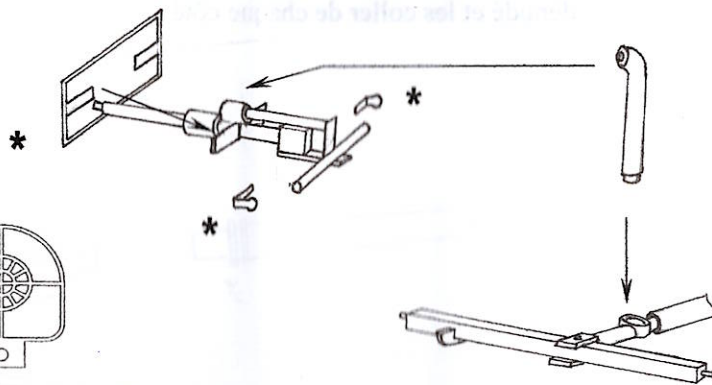
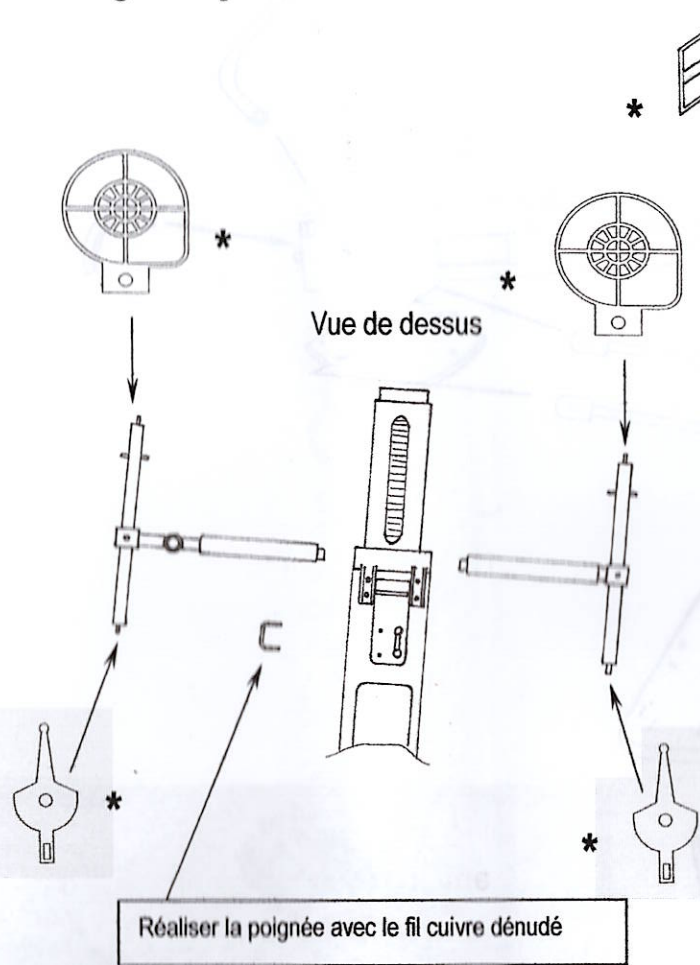

* : Photodécoupe

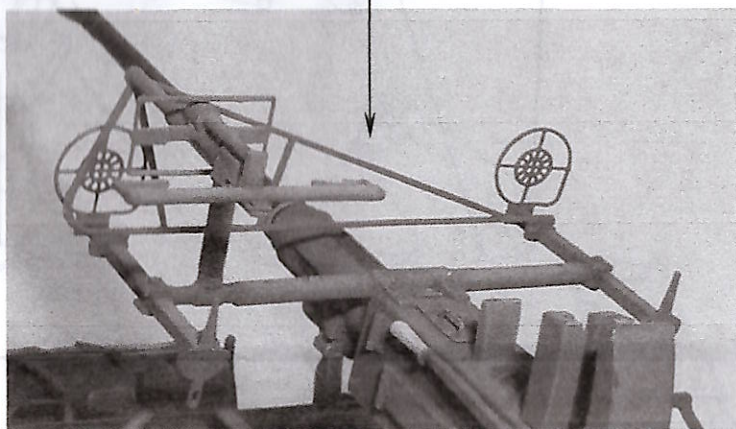
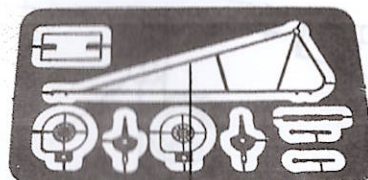

Fixation du canon de rechange

Pare-brise avec bâche.

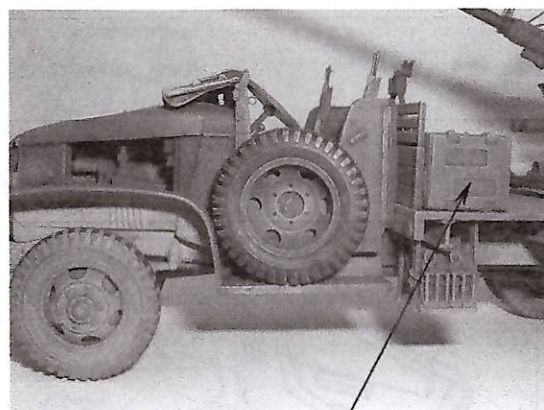
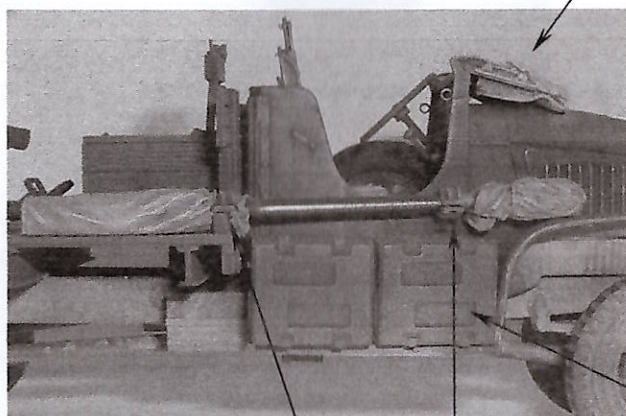

Fixations du canon de rechange.
Coller le collier de fixation sur la carrosserie du GMC.

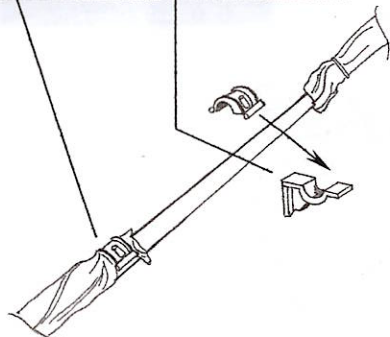

Caisses à munitions

Réaliser 2 poignées avec le fil dénudé et les coller de chaque côté

