

# P-51D Mustang IV

## 1:32 SCALE

## 美国 P-51D “野马” 战斗机

### READ BEFORE ASSEMBLY

- Study and understand these instructions thoroughly before beginning assembly. Make sure all parts are included by comparing them to those shown on pages 2 & 3 of these instructions.
- Remove parts from sprues as needed, and trim excess with a hobby knife. Be careful not to lose small parts.
- Remove photo-etch parts from sprue as needed using a hobby knife or photo etch cutter.
- Apply cement to photo etch parts as shown on instructions. Applying too much cement will restrict the operation of these

movable parts. Apply cement carefully! Removed photo etch parts can have sharp edges. Take care when handling these to avoid injury.

- Apply decals to necessary parts prior to assembly.
- Additional tools recommended(not included):Sprue cutter, Long nose pliers, hobby knife, file, tweezers, pin vise, scissors, cement, sandpaper, soft cloth, glue and paint.

### 装配之前仔细阅读

- 小心用模型锉刀锉平所有零件表面的注射浇口。
- 小心用刀片切下蚀刻片零件，不要遗失小零件。
- 用强力快干胶水粘合蚀刻片零件和金属轴。过量的快干胶水使用可能导致可动零件会粘住，小心涂胶。
- 取蚀刻片时应特别注意安全，防止利边划伤手指。
- 某些零件表面需贴水贴纸，请选择在装配的同时进行。
- 推荐模型工具(自备)：胶水，水口剪刀，长咀钳，刀片，锉刀，镊子钳，钻，剪刀，瞬间快干胶。
- 软布同砂纸同时也应该是必备工具。
- 请使用塑料胶水和油漆，模型内不含。

### 水贴纸的使用:

1. 从水贴纸上剪下印花;
2. 将印花放入温水中浸10秒, 然后放在干净布上。
3. 拿着印花纸板将印花移到模型上;
4. 手指蘸水将印花移到适当的位置;
5. 用软布轻压印花直至水干, 汽泡消失。

### DECAL APPLICATION

1. Cut off decal from sheet.
2. Dip the decal in tepid water 40°C for about 10 sec. and place on a clean cloth.
3. Hold the backing sheet edge and slide decal onto the model.
4. Move decal into position by wetting decal with finger.
5. Press decal gently down with a soft cloth until excess water and air bubbles are gone.



cyanoacrylate glue  
使用强力胶



weight  
配重



make hole  
钻孔



cut / remove  
切除



option  
选择



no cement  
不涂胶水



decal  
贴纸



bend  
弯曲



file / sand  
锉平

部品图  
Parts

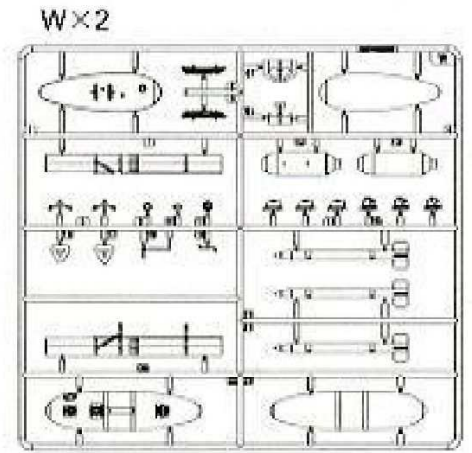
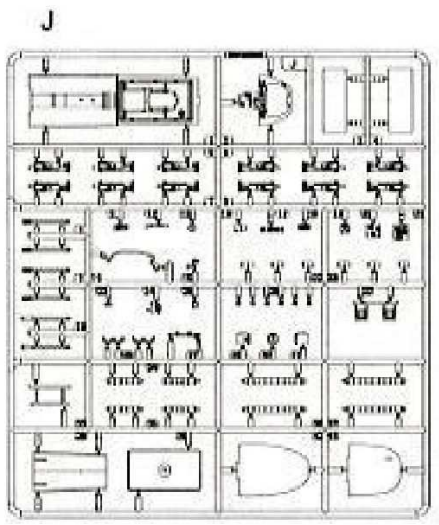
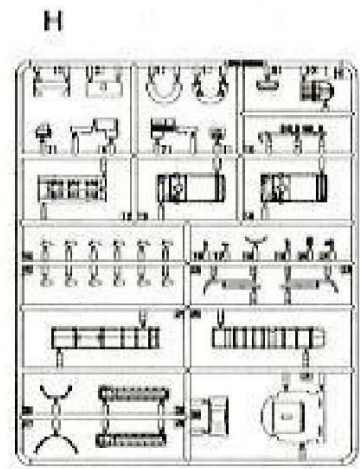
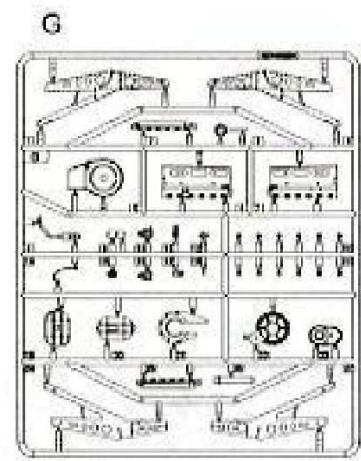
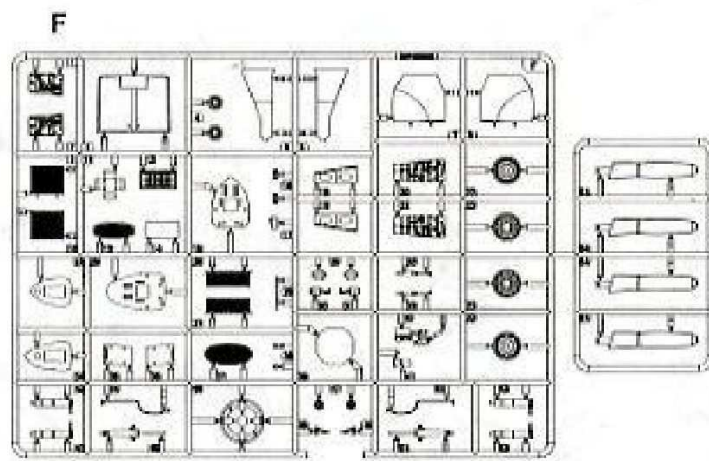
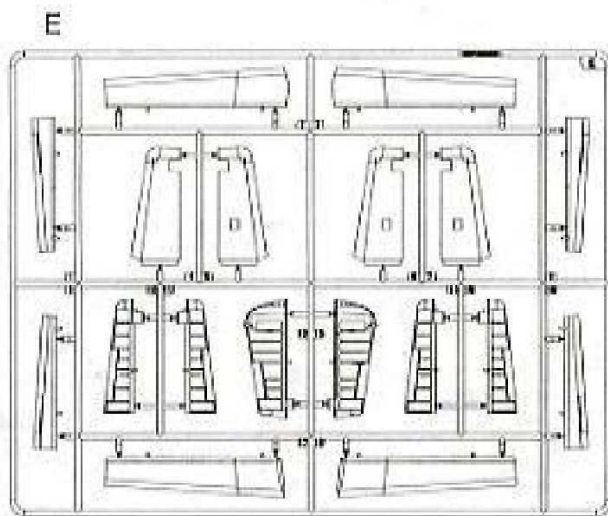

# 部品图 Parts

CX2 含一透明件  
Including a clear part

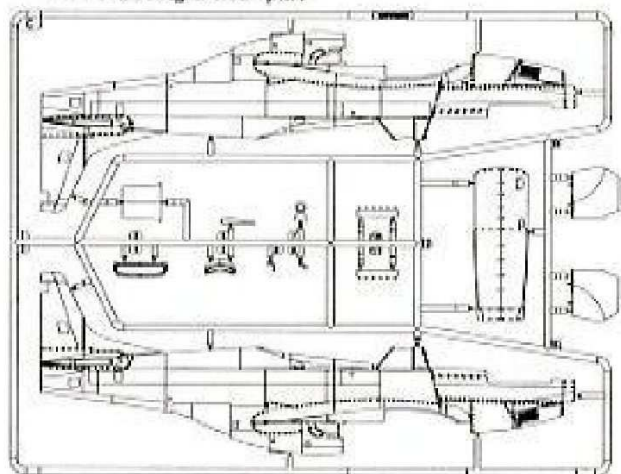

D

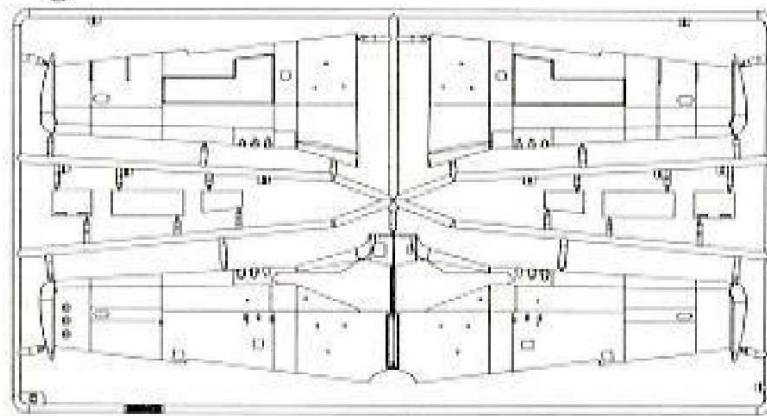

<<主轮胎>>x2  
Main tyre



<<尾轮胎>>  
Tail tyre

L

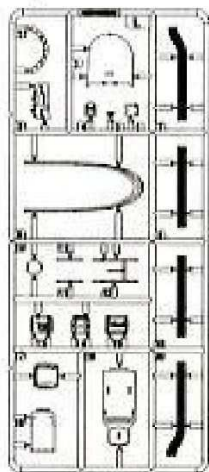

N

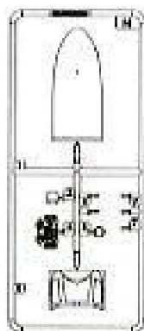

<<蚀刻片>>

Photo etched Parts(PE)

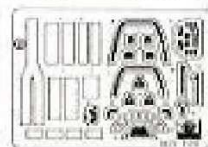

<<水贴>>  
Decal

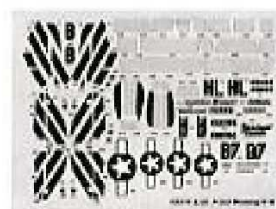

A

<<水贴>>  
Decal

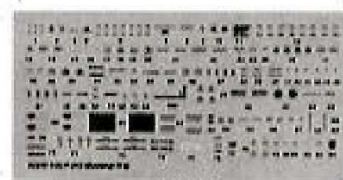

B

<<菲林片>>  
Film Part



02075 1/32 P-BID Modeling IV

不用零件: F7,F8,F25,F34,G3,H14,H15,H19,W7,W16,W17,W20  
Unused Parts:

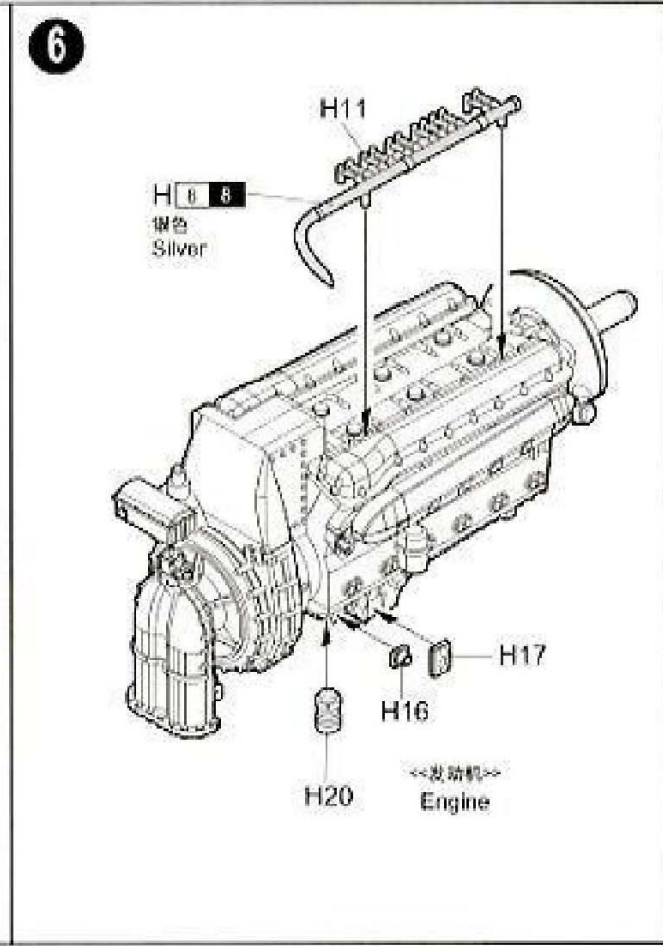
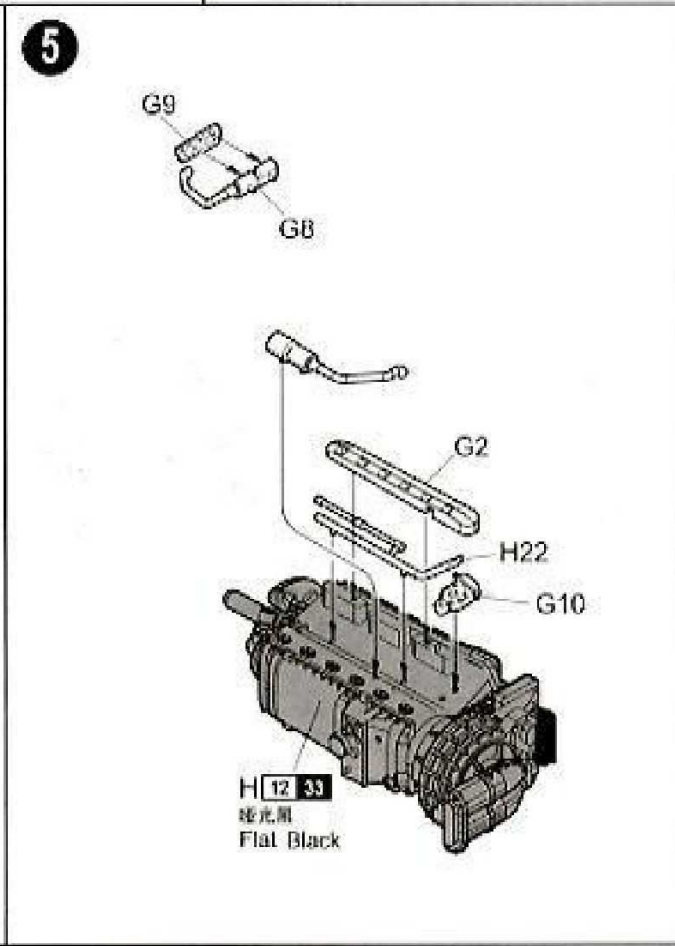
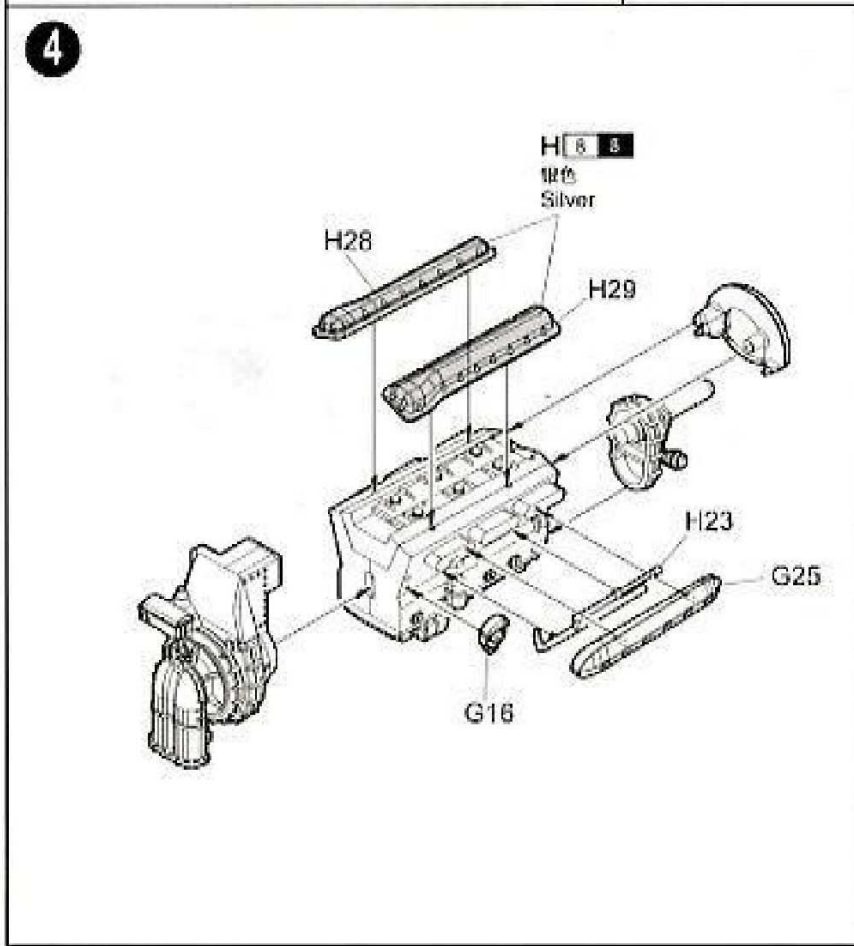
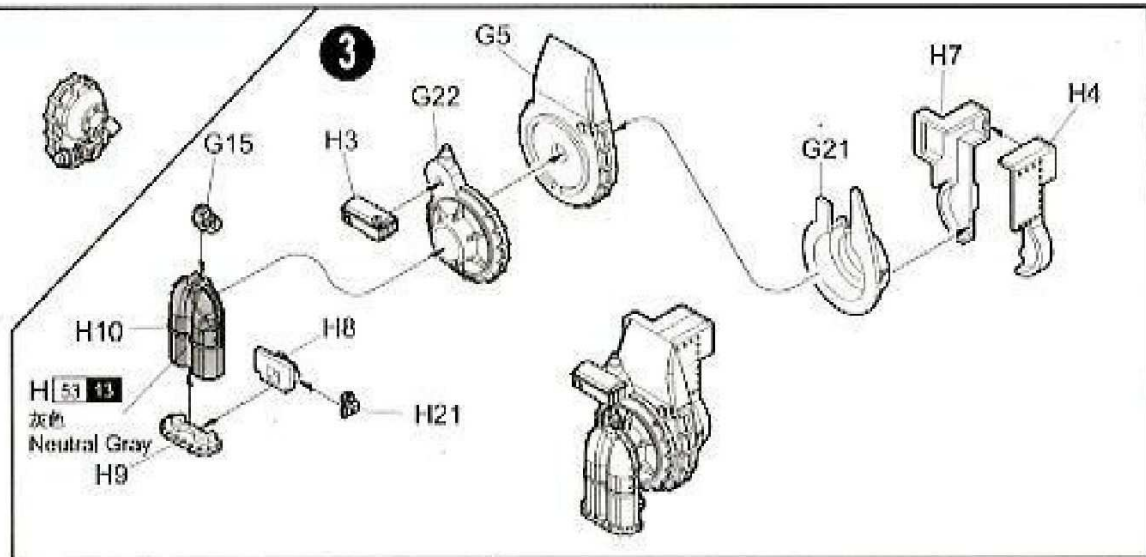
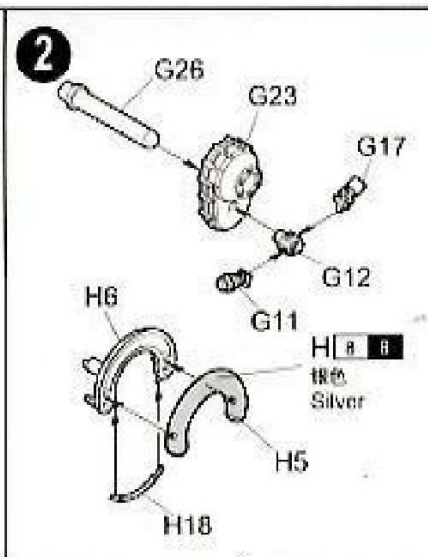
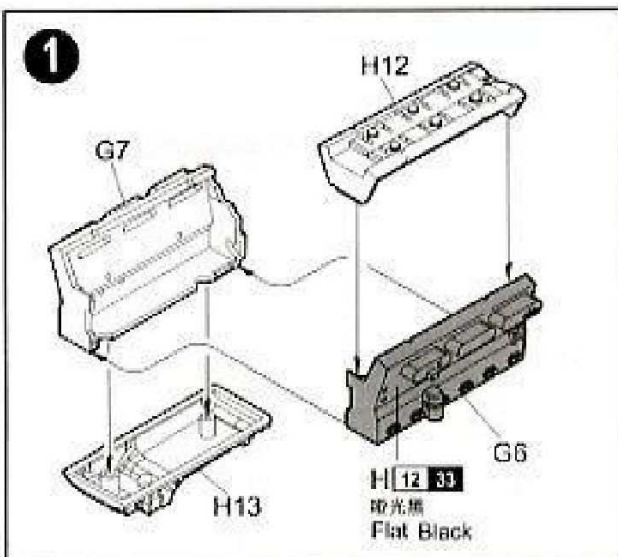

7

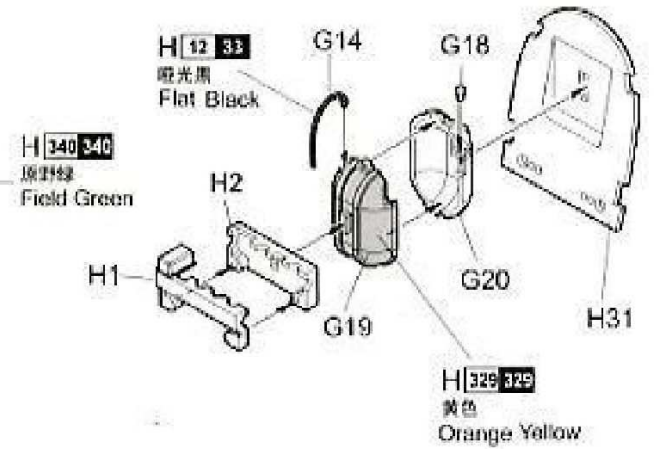
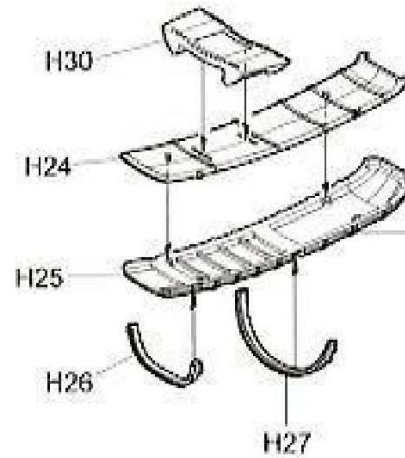
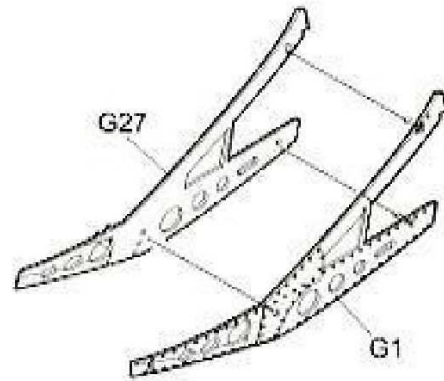
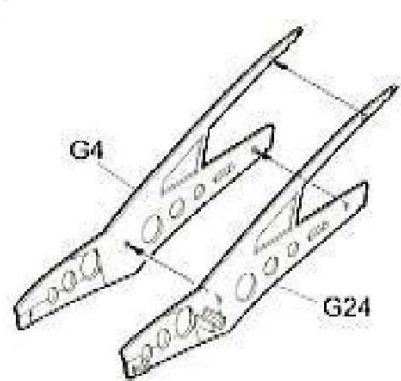

8

H 340 340  
原野绿  
Field Green

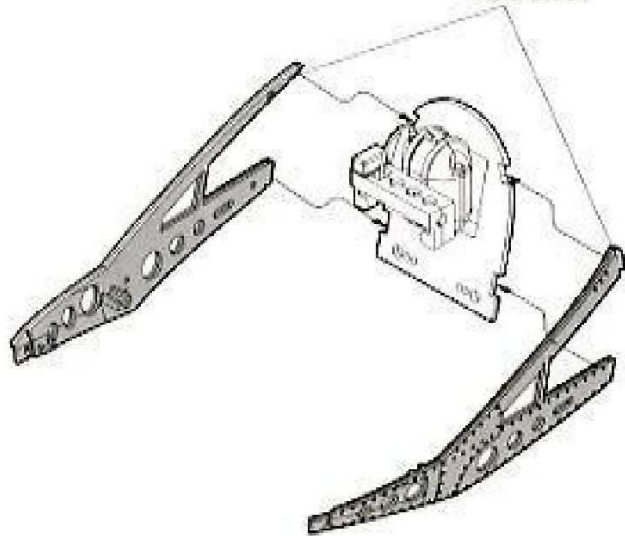

9

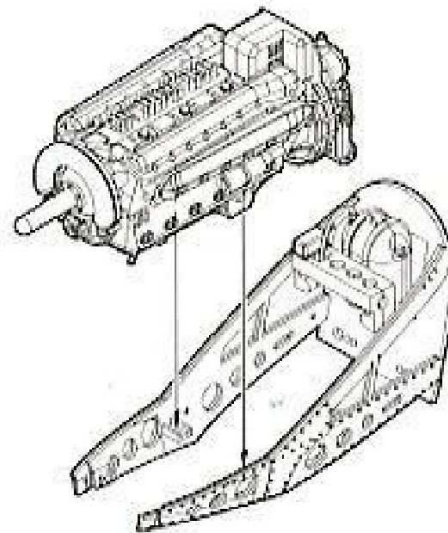

10

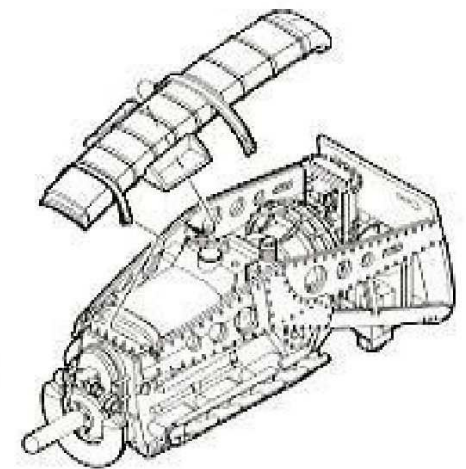

<<发动机>>  
Engine

制作2组  
Make two

H 8 8  
银色  
Silver

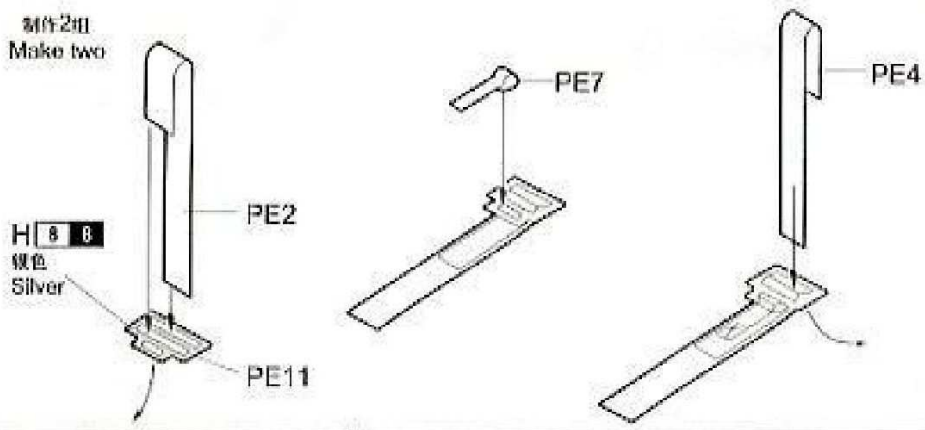

11

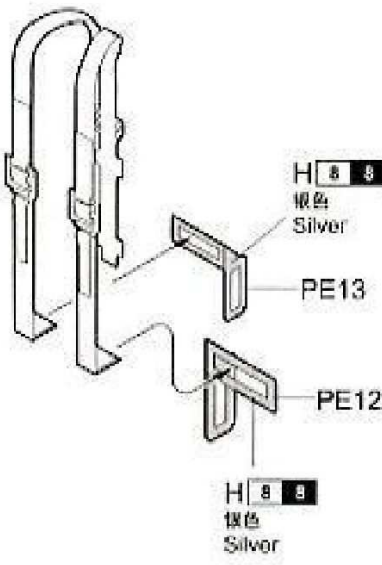
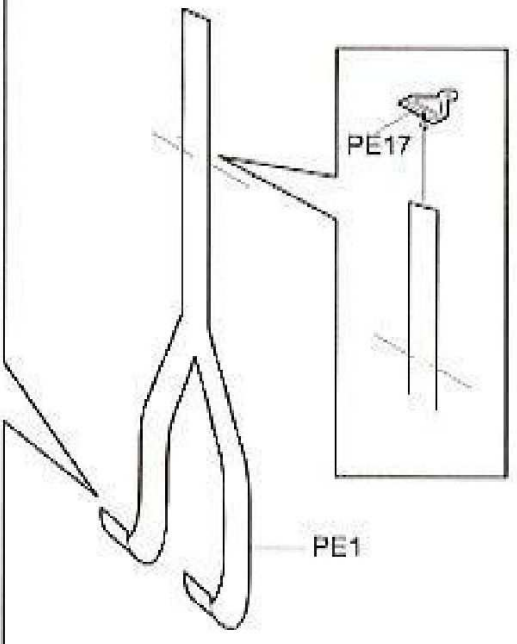
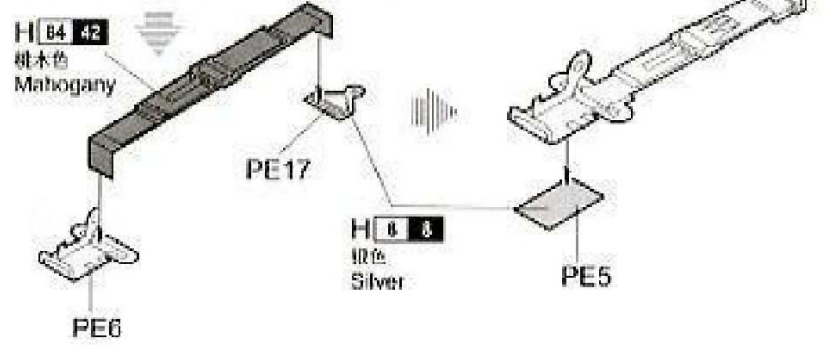
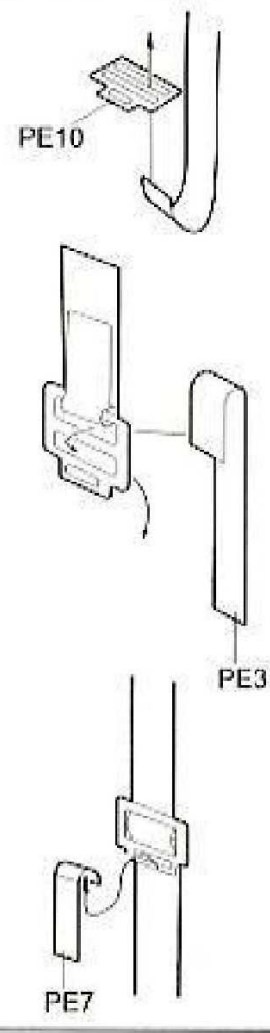
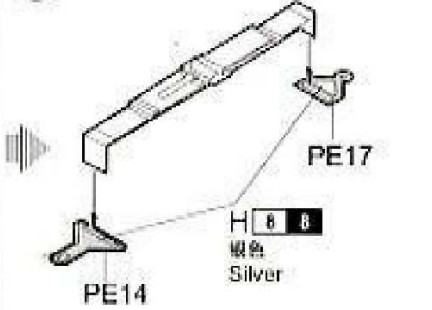

12

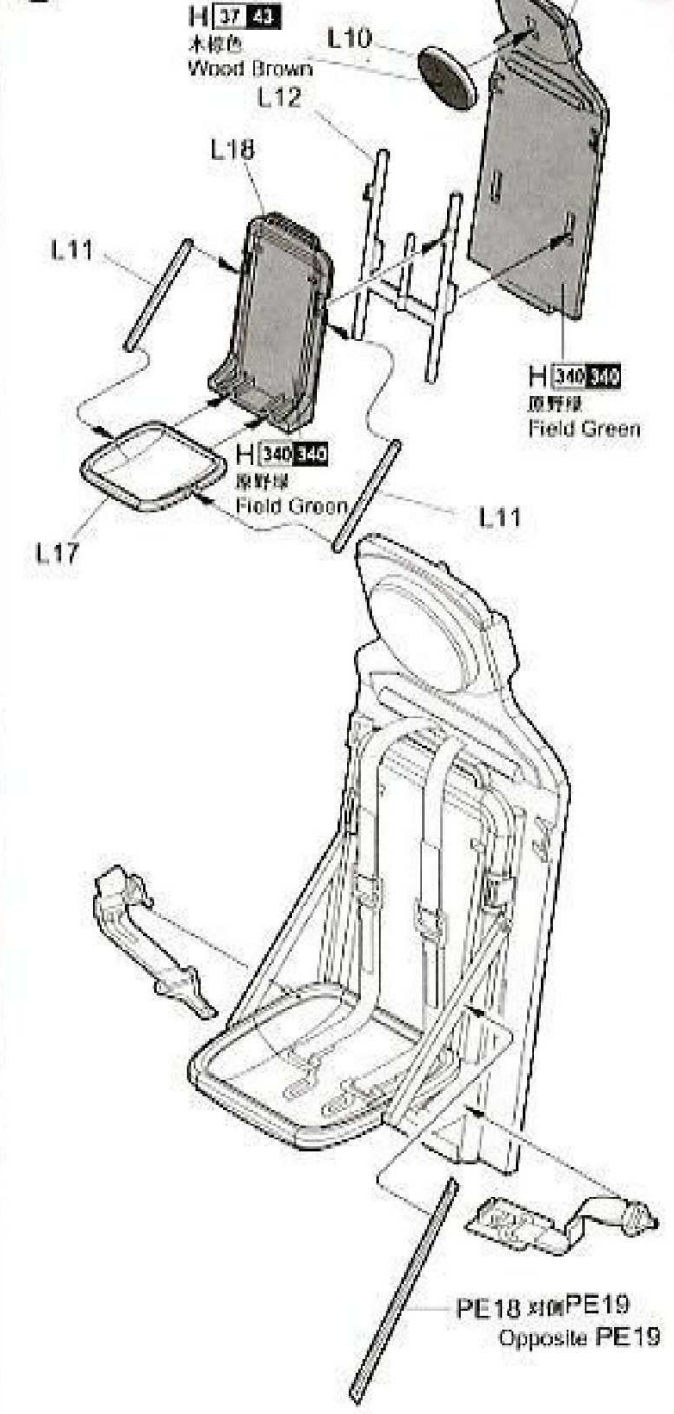

13

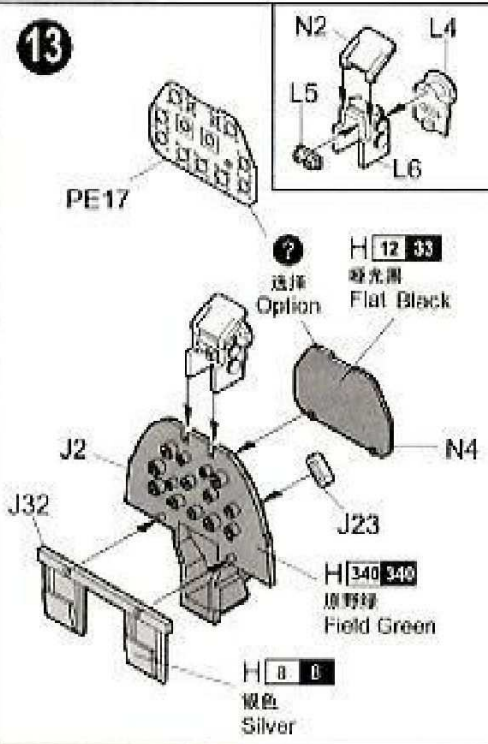

14

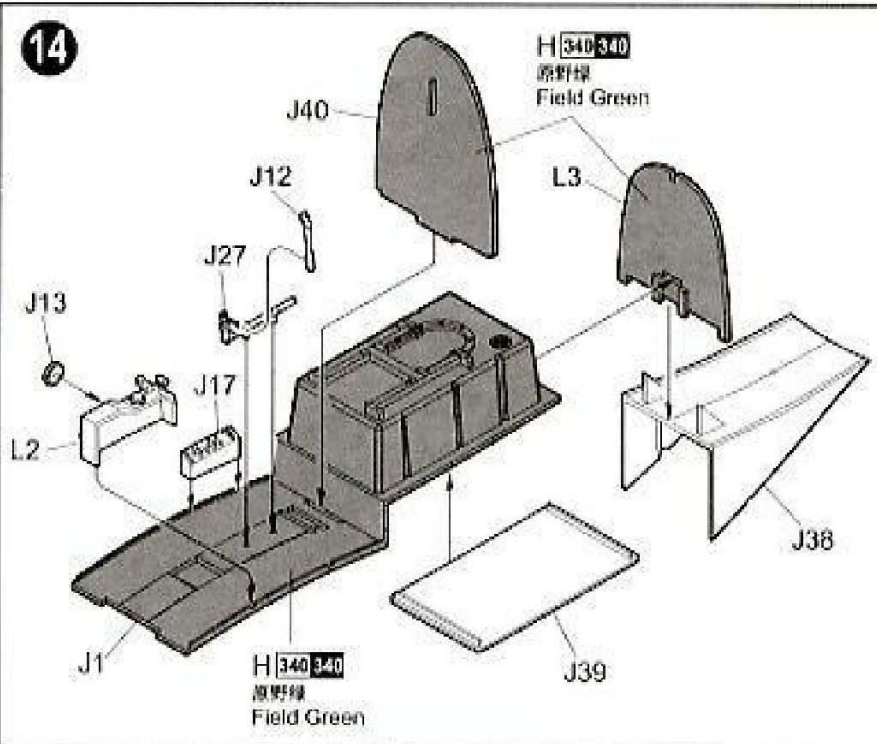

15

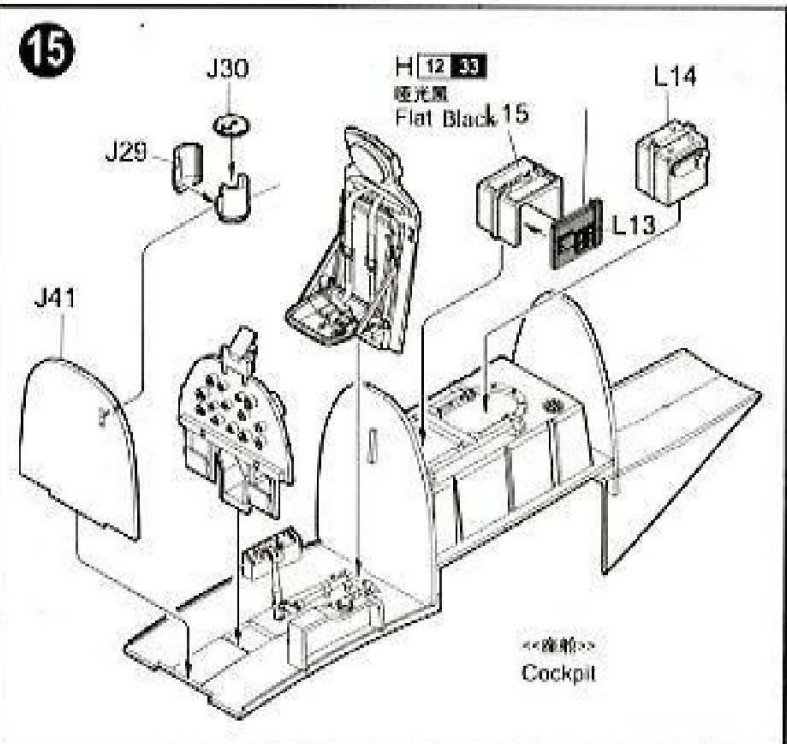

16

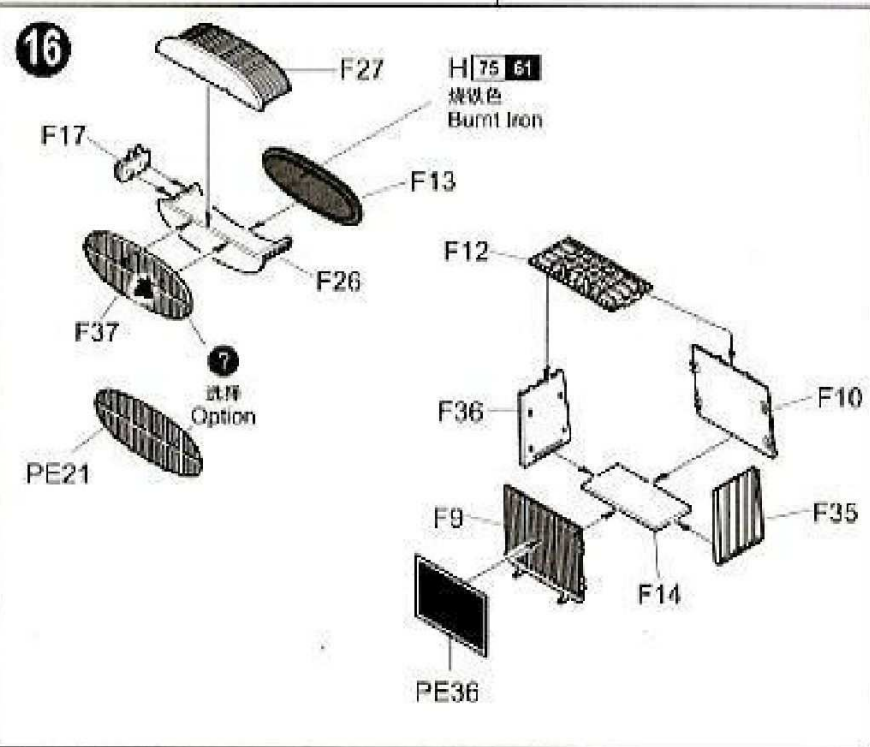

17

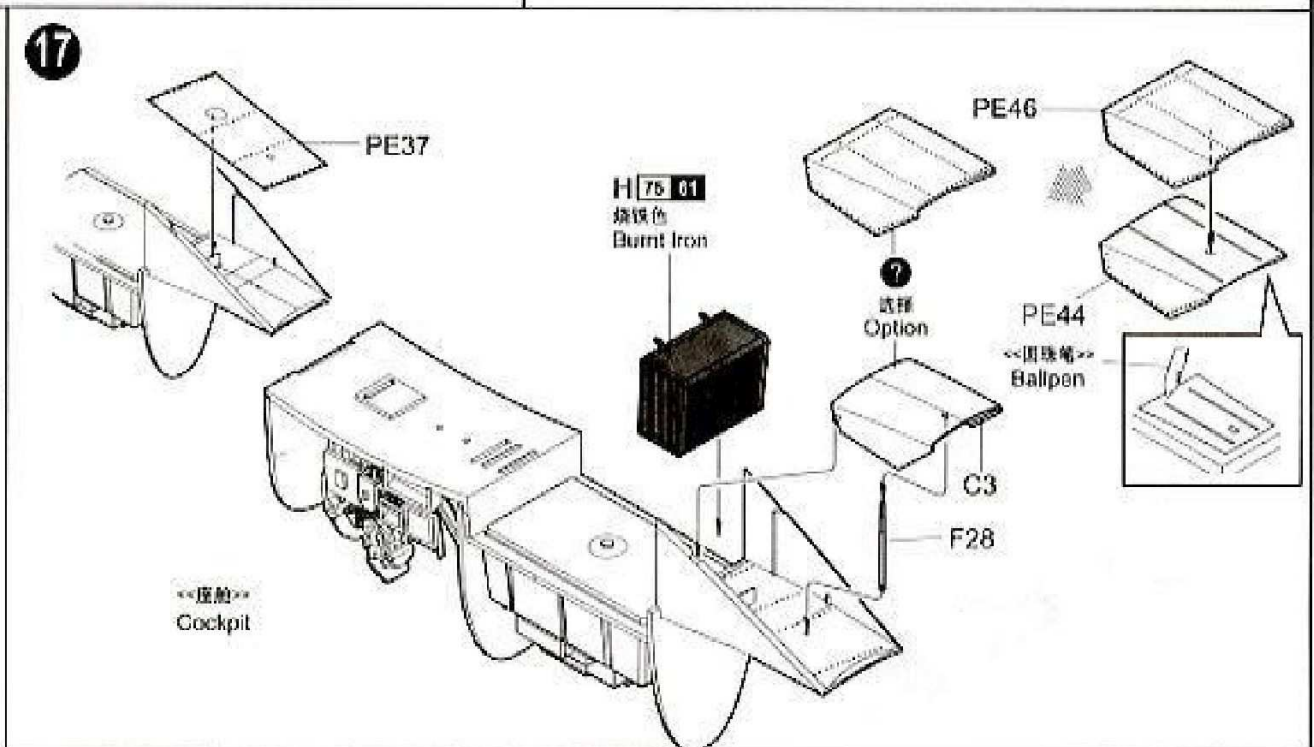

18

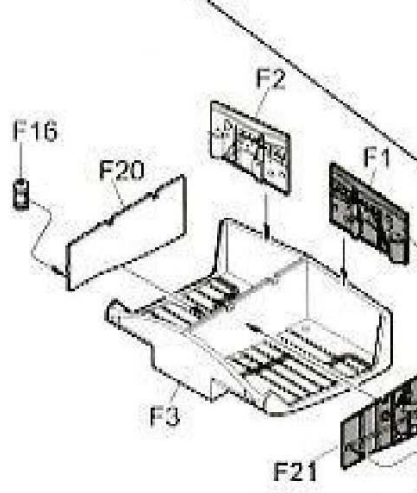
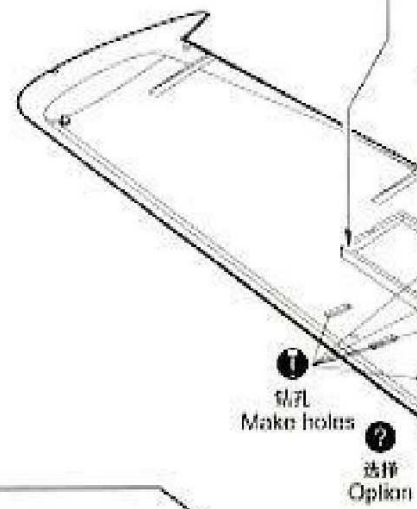
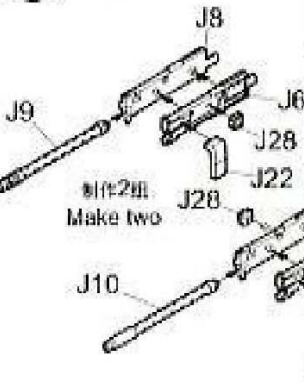

19

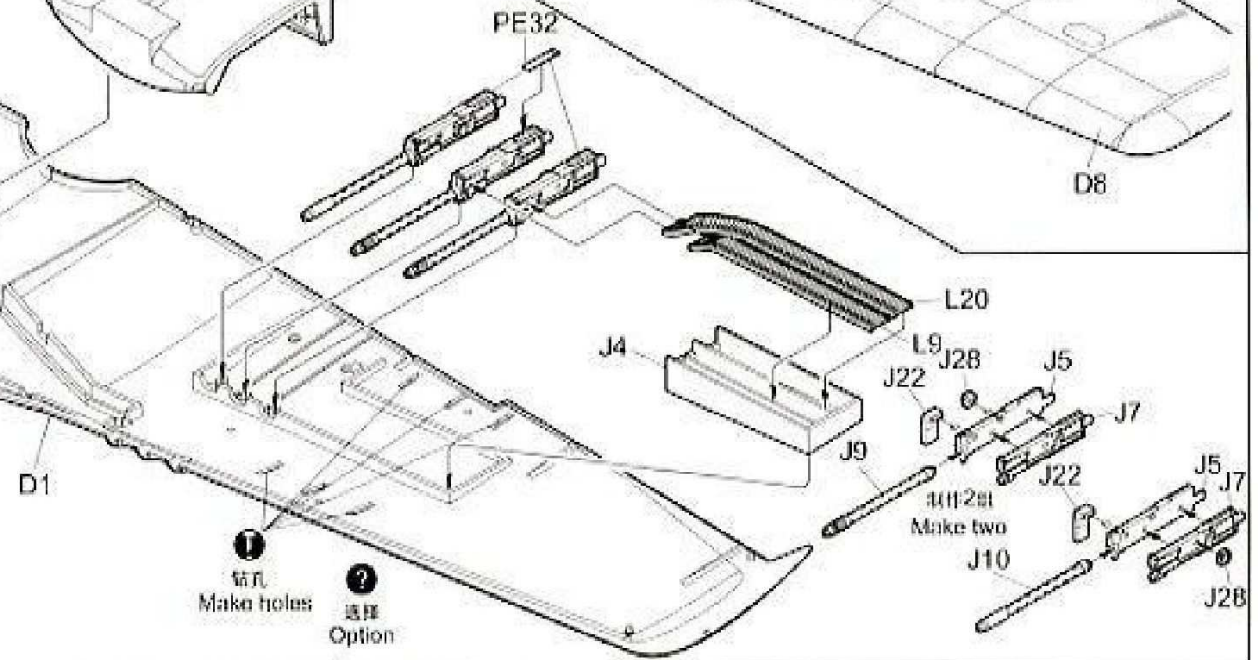
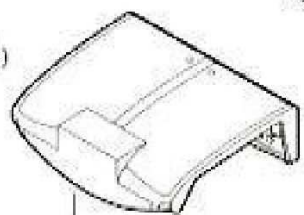
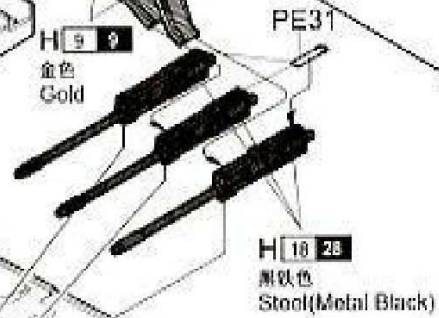
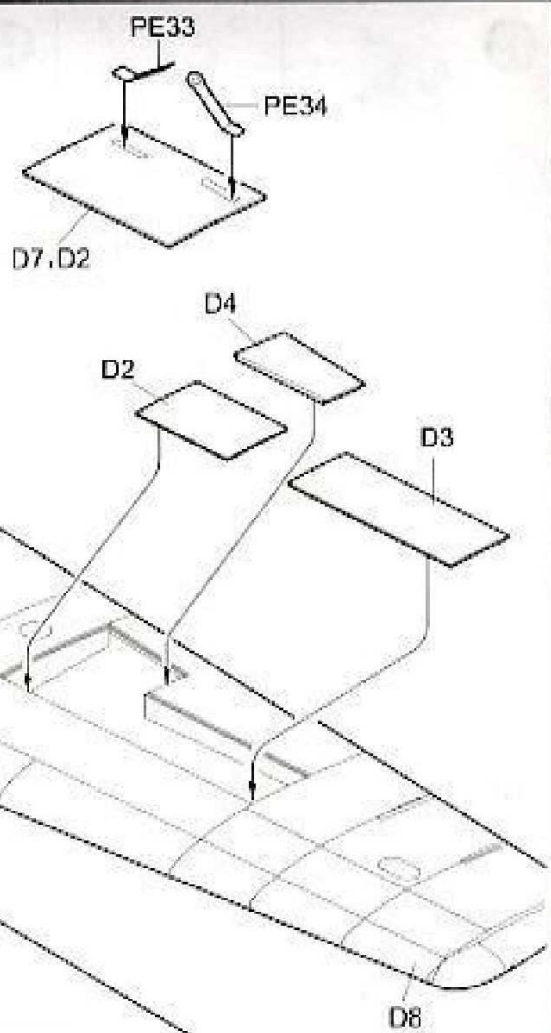
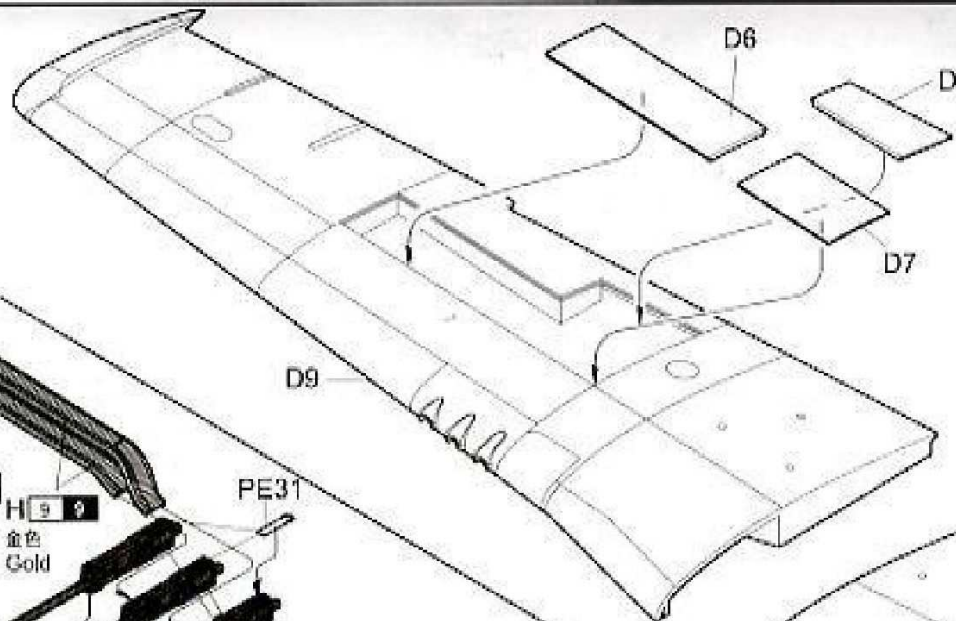



20

PE29(PE30)

PE30

E9

E1

E17

N3

PE30

PE29

E2

PE29

E16

E8

E18

E3

N3

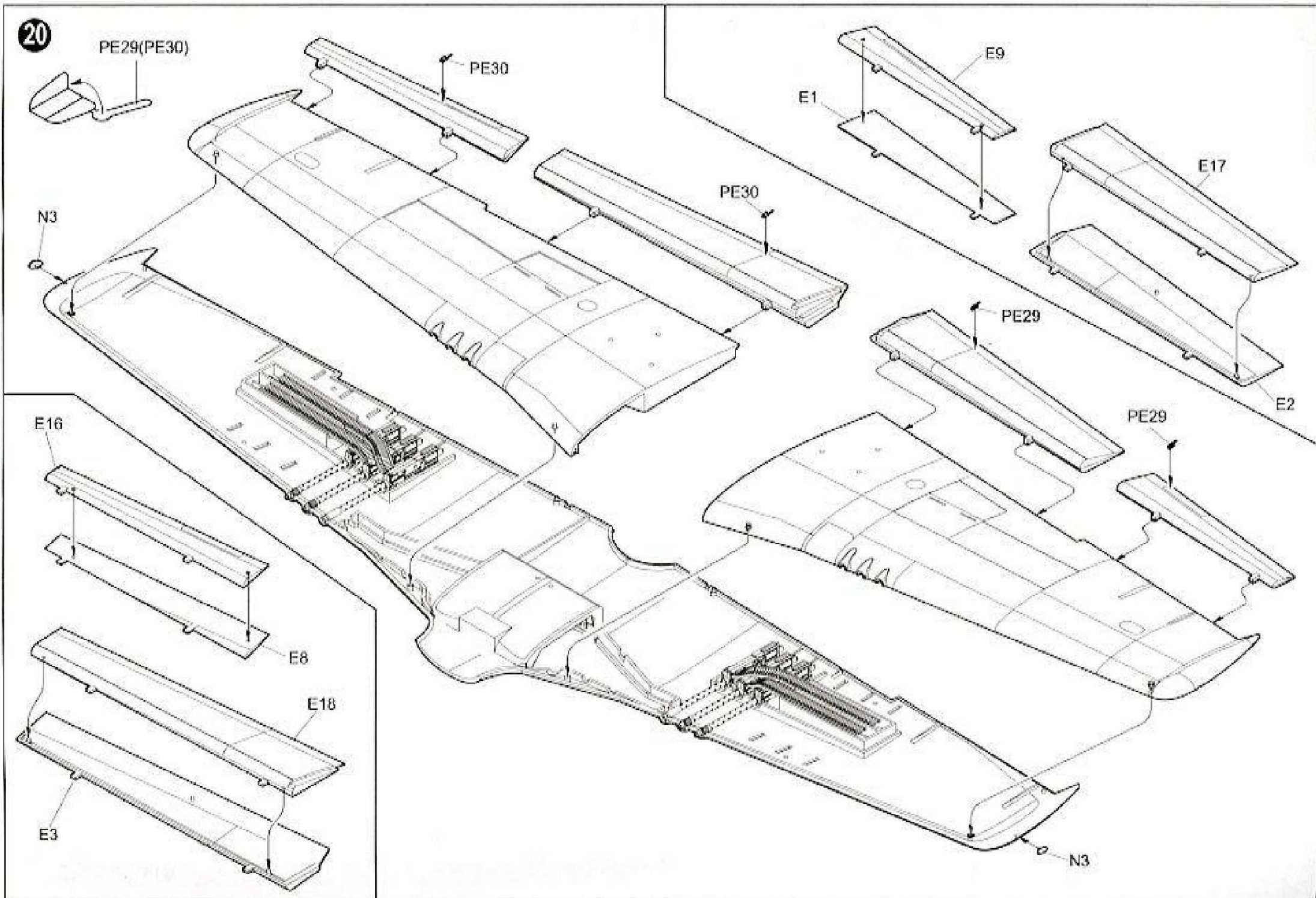

21

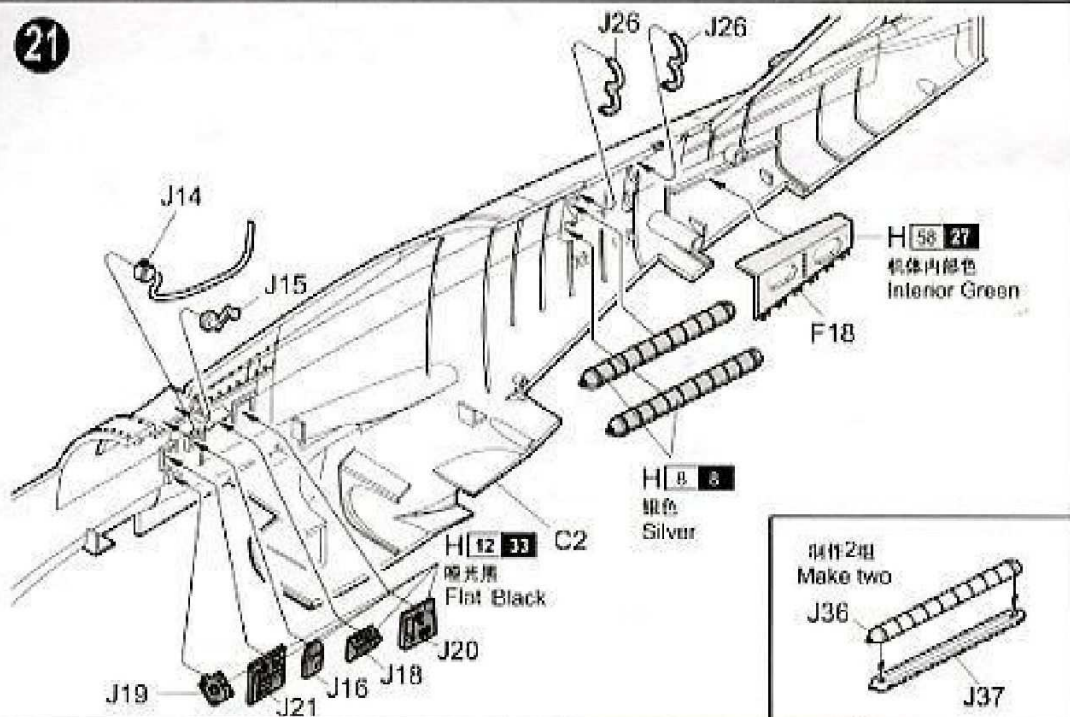

22

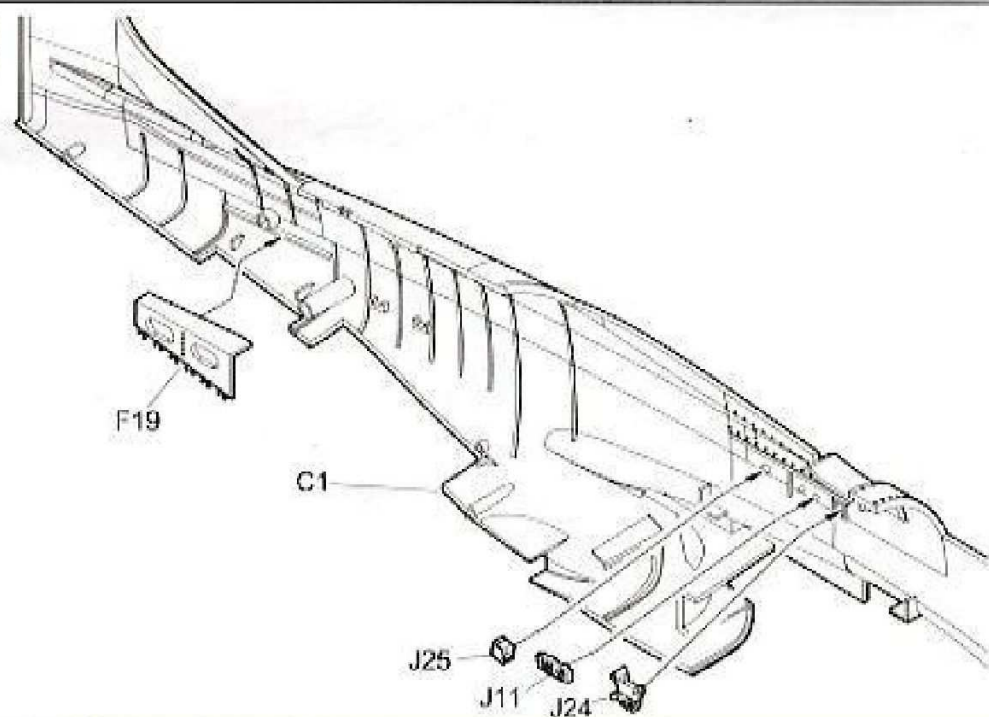

23

右侧水平尾翼  
Right horizontal stabilizer

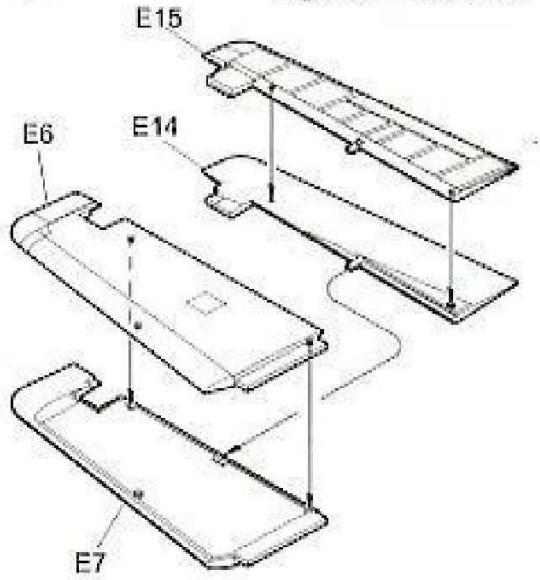

24

左侧水平尾翼  
Left horizontal stabilizer

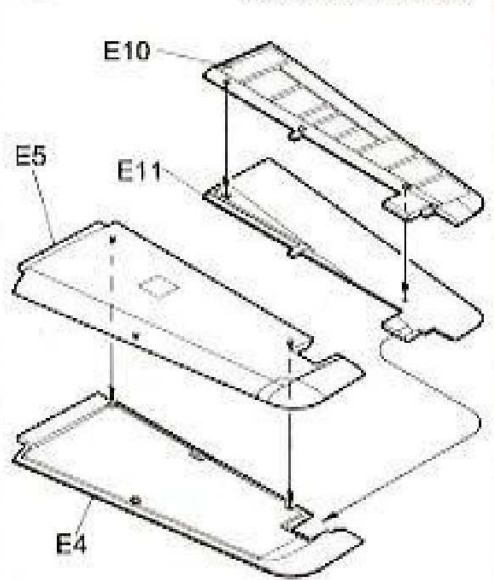

25

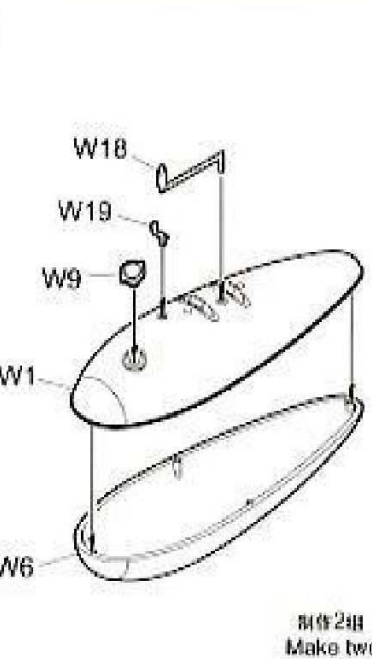

26

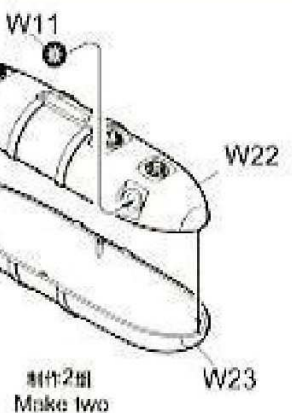

27

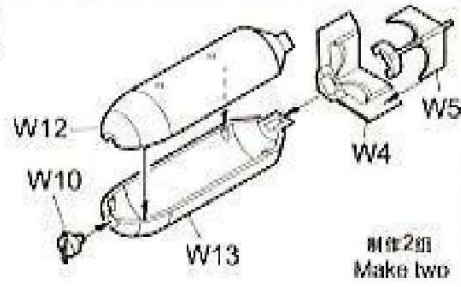

28

29

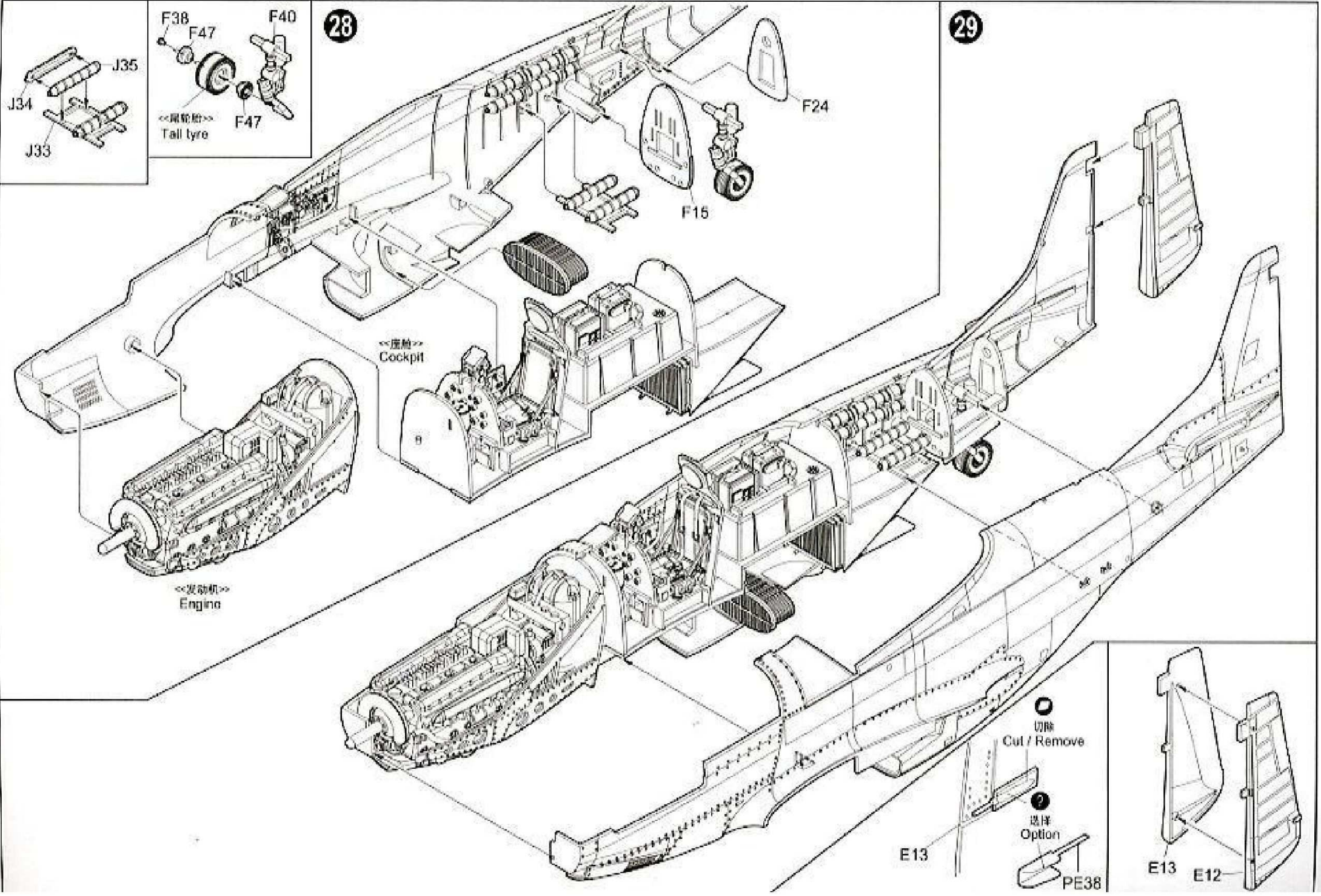

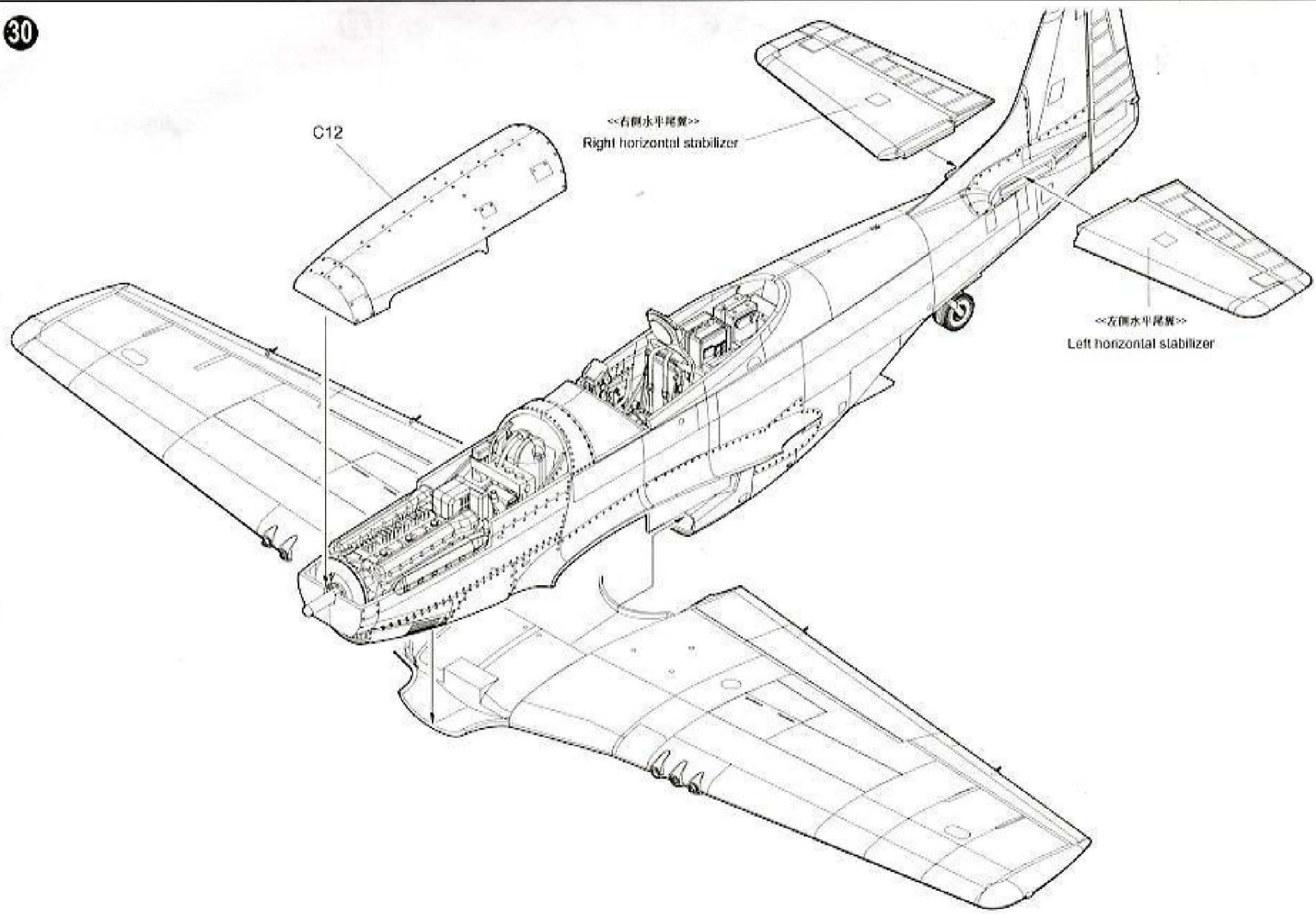

31

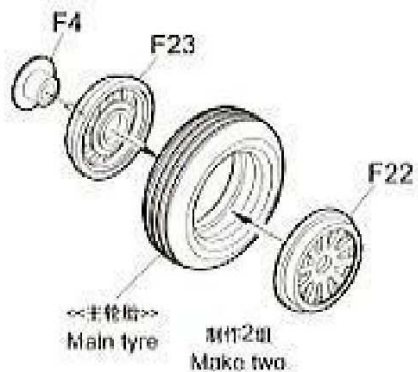

32

<<右侧轮胎盖板>>  
Right gear cabin cover

<<左侧轮胎盖板>>  
Left gear cabin cover

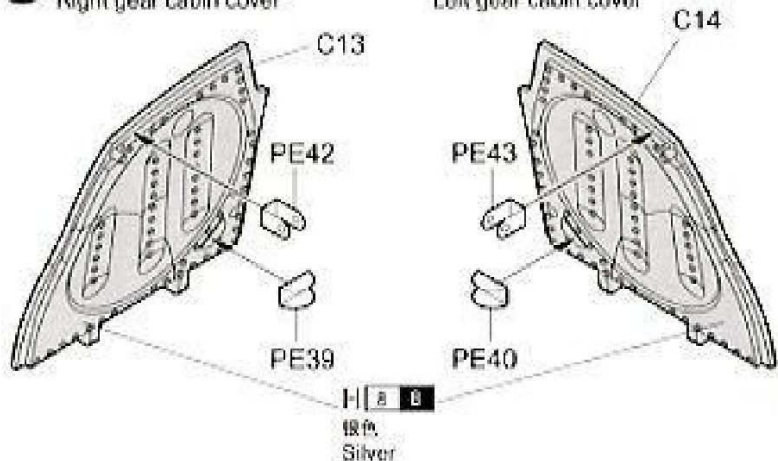

33

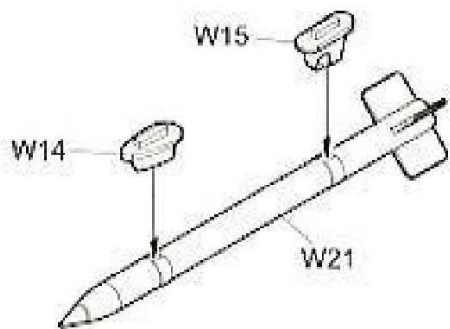

制作6组  
Make six

34

<<右侧车架>>  
Right undercarriage

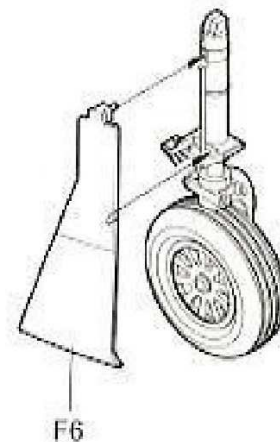
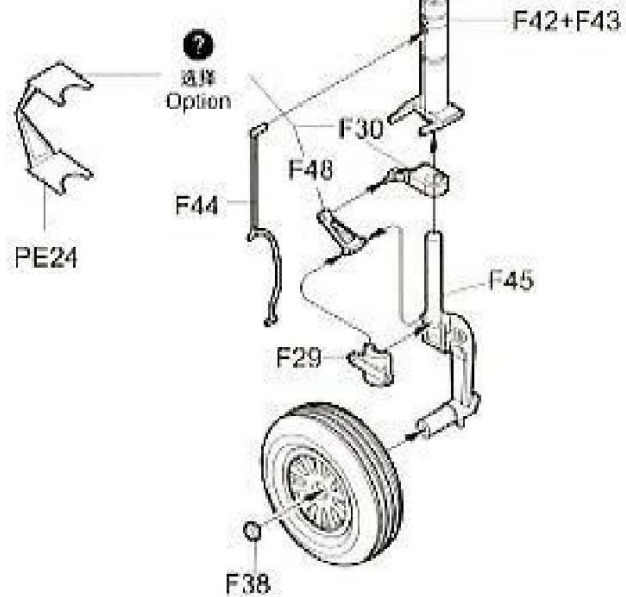

35

<<左侧车架>>  
Left undercarriage

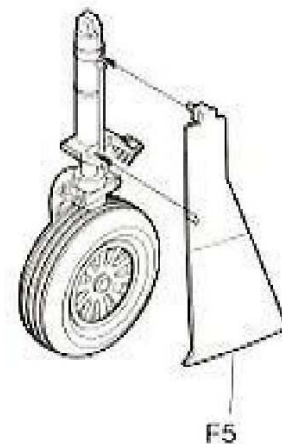
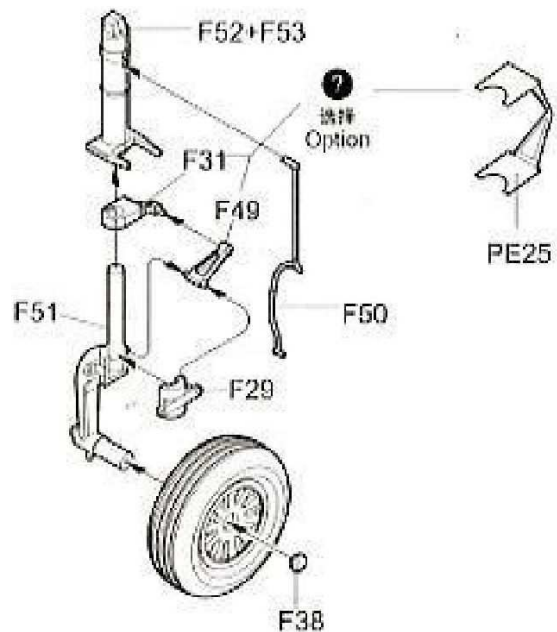

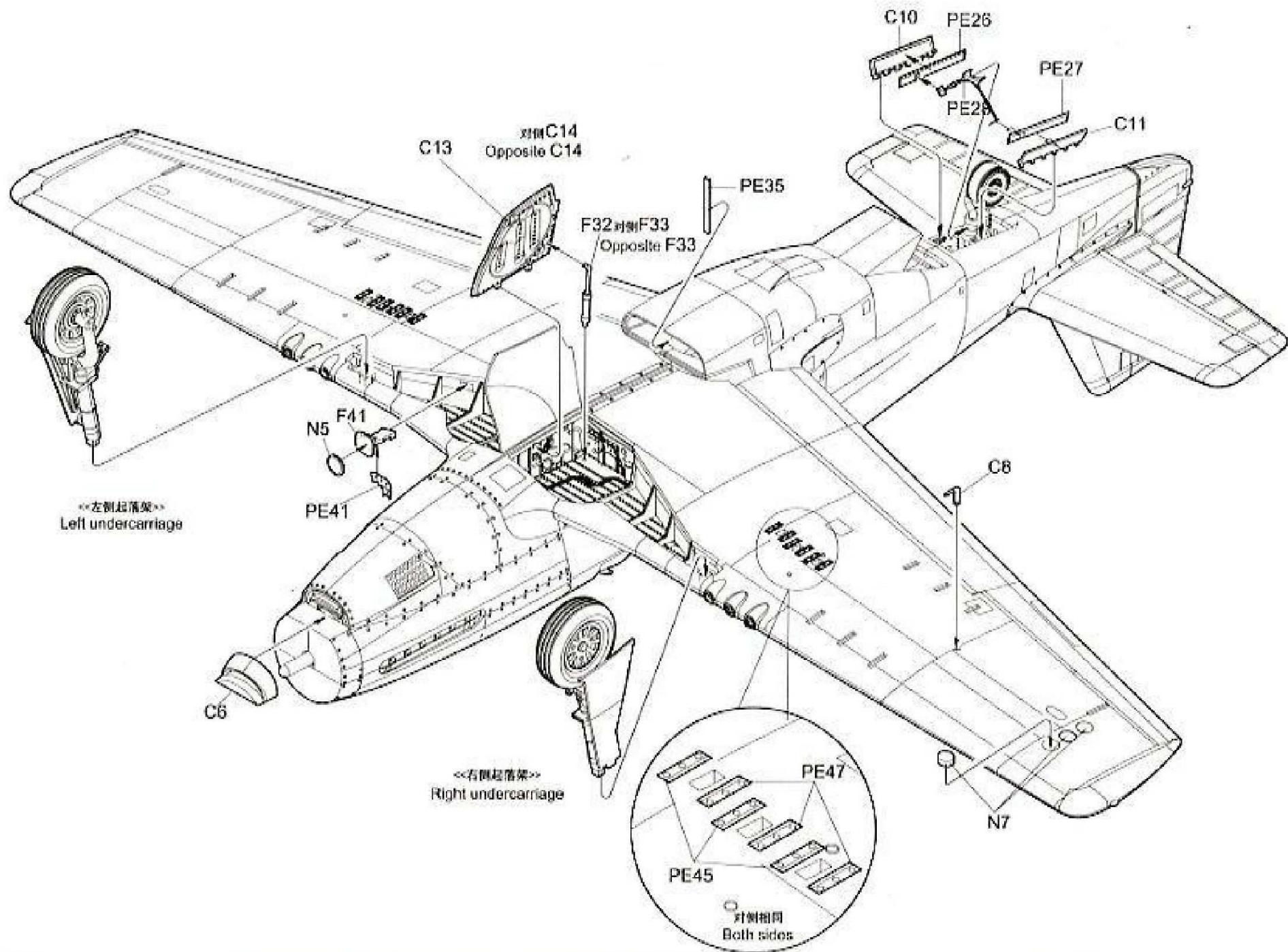

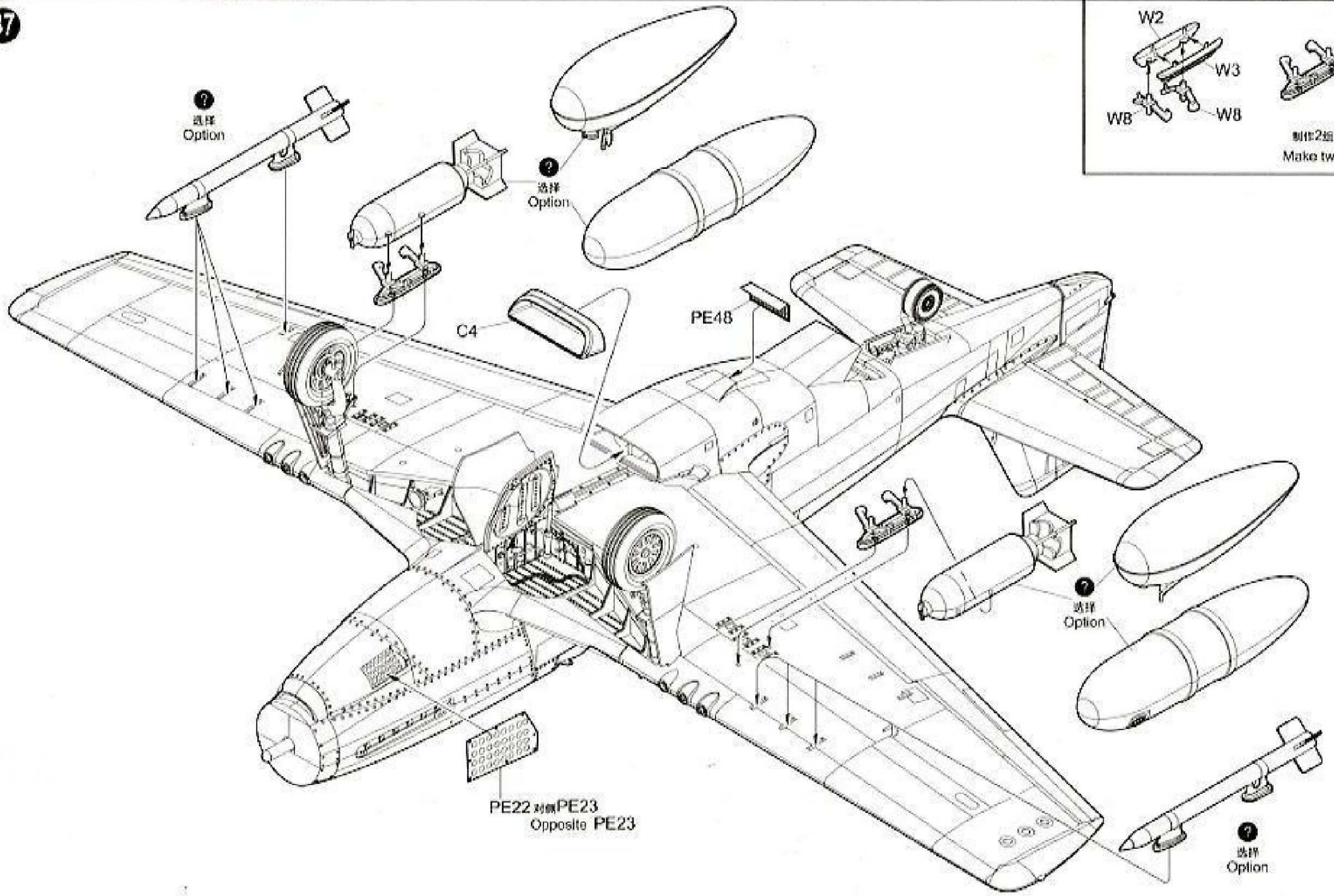

2 Option

2 Option

2 Option

2 Option

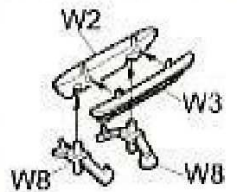

制作2组  
Make two

C4

PE48

PE22 对 PE23  
Opposite PE23

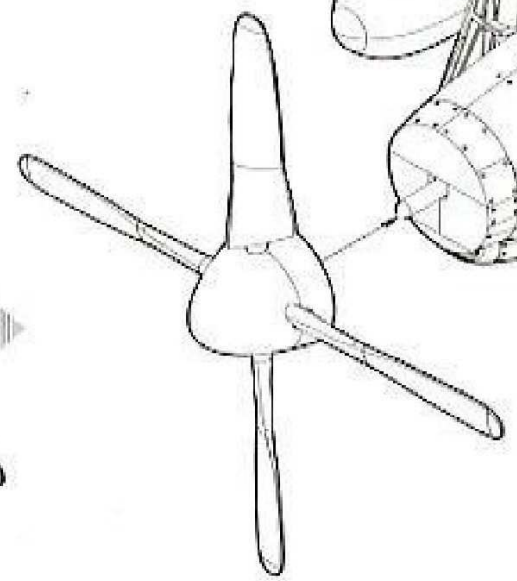
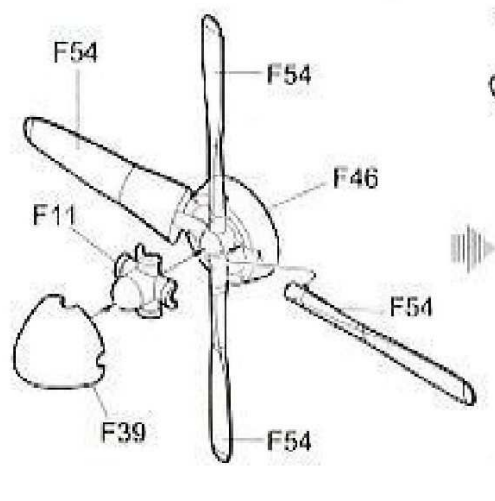
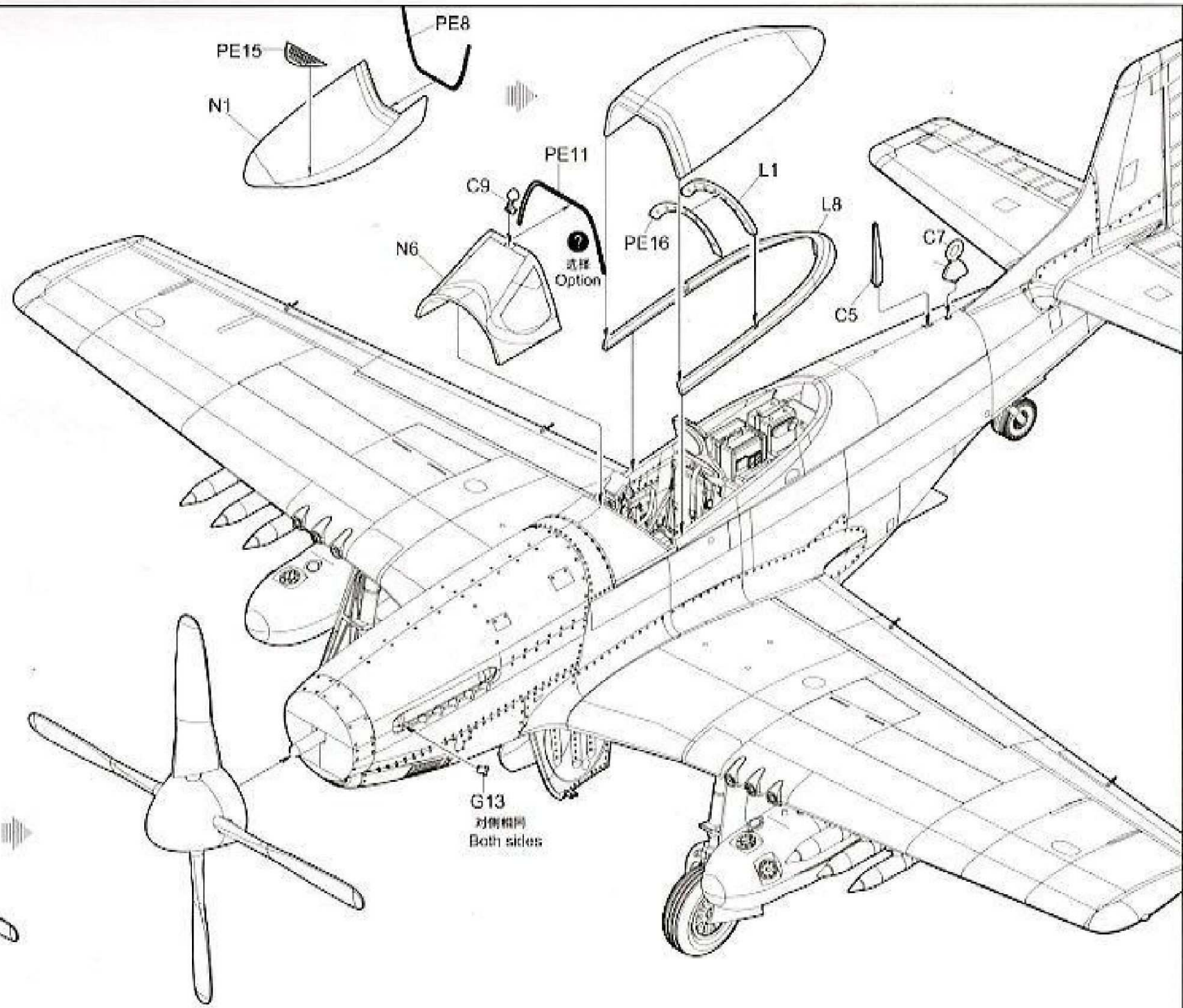

7  
选项  
Option

G13  
对侧相同  
Both sides



涂装同标贴指示  
Painting & Marking guide

Color	Mr.Hobby	Vallejo	Model Master	Tamiya	Humbrol
Grey 灰色	H[22] 13	952	—	—	5
Interior Green 机体内绿色	H[58] 27	—	—	—	—
Red 红色	H[3] 8	908	1503	X7	19
Silver 银色	H[8] 8	997	1546	X11	11
Olive Drab 橄榄色	H[304] 304	887	1711	XF62	155

Color	Mr.Hobby	Vallejo	Model Master	Tamiya	Humbrol
Ira Black 黑色	H[77] 137	—	—	—	—
Insigma Yellow 黄色	H[329] 329	—	1514	X8	188

**A** P-51D 44-15459(HL-B)  
Pilot John J.Voll, of 308 Sqn, 31FG, 306FS, Italy, 1944.

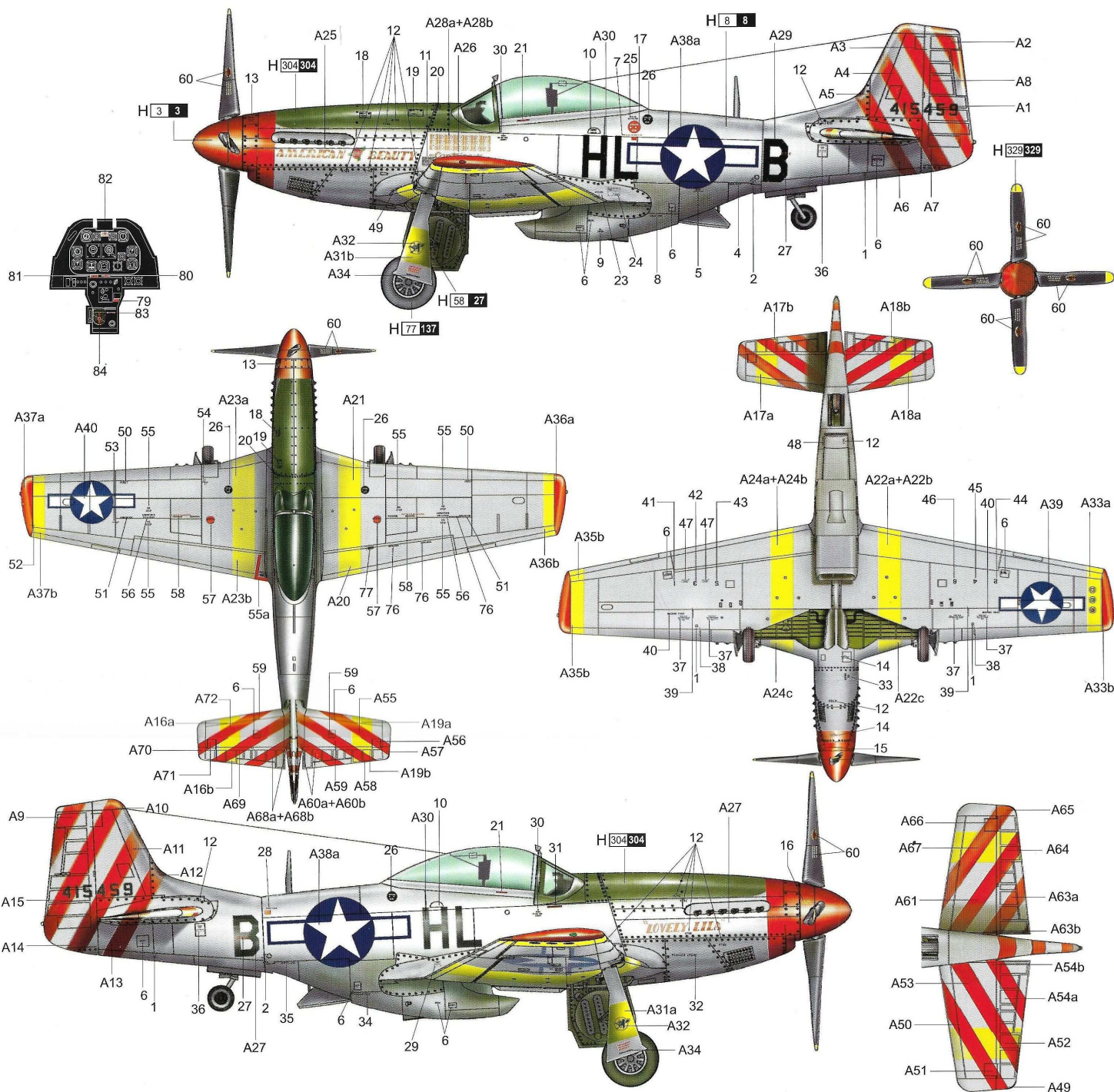

**B** P-51D flown by Wallace Hopkins, Captain 374 FS, France 1944.

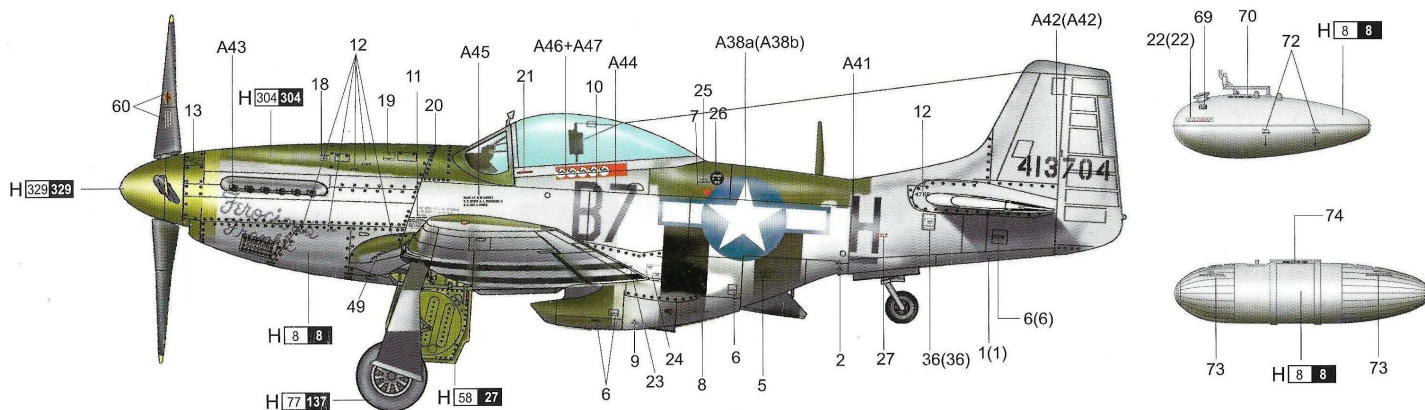

H[ ] AQUEOUS HOBBY COLOR    X Mr. COLOR