

Revell

VIETNAM AIR BATTLE - PHANTOM II vs MIG-21

4747-3800

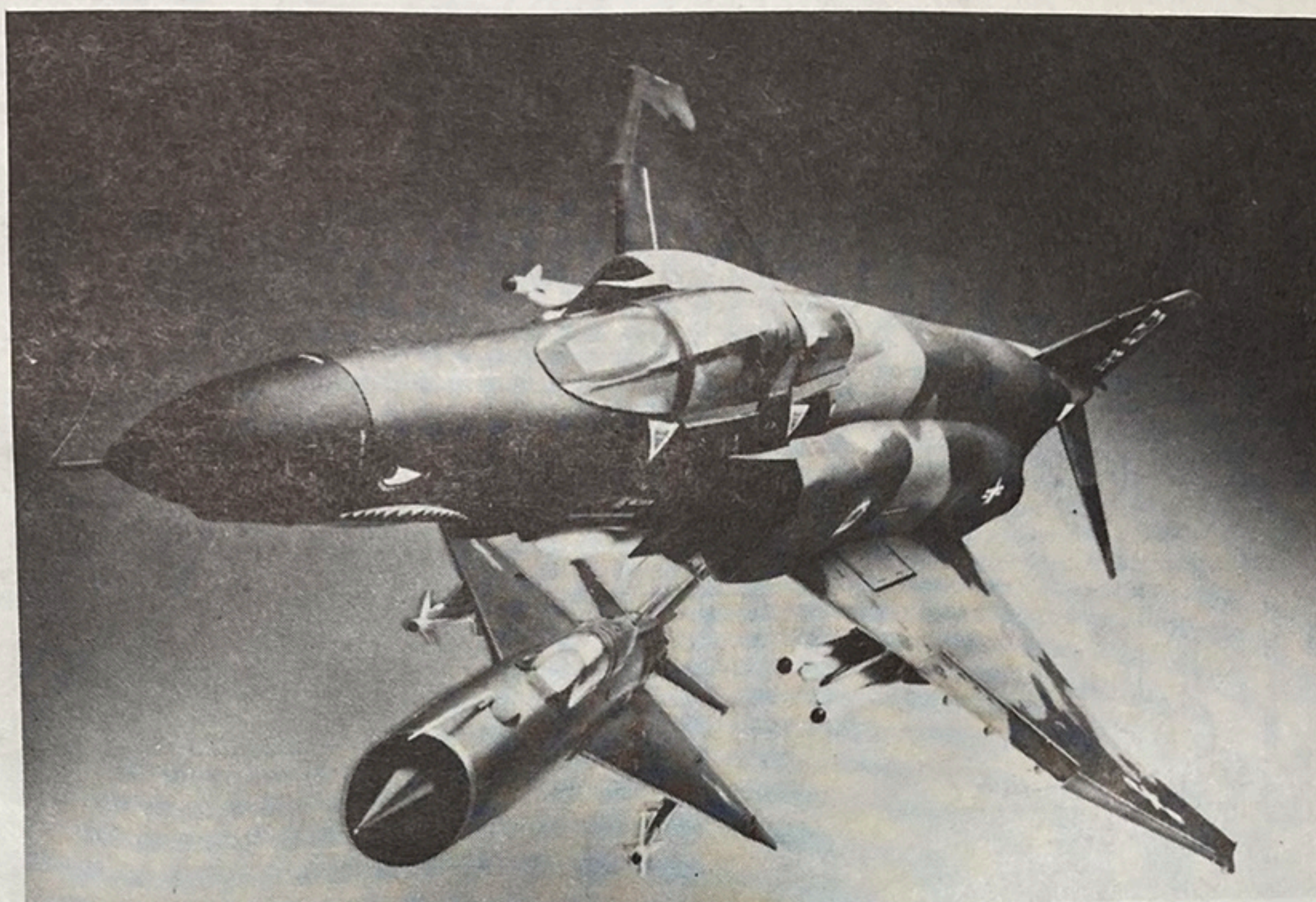

The war in Vietnam was fought largely in the air with the most modern equipment available from the American and Russian arsenals. It was thus inevitable that the McDonnell F-4 Phantom II and the MiG-21 would become antagonists.

Although the Phantom is powered by two engines and MiG-21 only one, both planes have a top speed well above Mach 1.0. The Phantom is a much larger aircraft than the MiG-21 and was used as a multi-role fighter. Both planes are armed with cannons and can use several types of missiles, both of the infrared and radar-homing or guided versions. A second man in the Phantom operates the electronics controlling the radar and weapons, while the MiG pilot must handle the entire operation by himself.

It is unfair to make a direct comparison between the Phantom and MiG-21, although they were used in the same dogfighting role. They both proved to be outstanding fighting machines, leaving it to the proficiency of the pilots to determine the outcome of the battle.

This F-4E Phantom model bears the markings of ace Steve Ritchie, of the 555th TFS, 432 TRW, who was credited with five MiG's, three in an F-4D. North Vietnamese pilots rarely carried their scores on the airplanes they flew since their pilots were seldom assigned to a plane. The markings on this kit are unusual in that most North Vietnamese MiG's were unpainted metal.

ENGLISH: ASSEMBLY DRAWINGS SHOULD BE REVIEWED BEFORE PROCEEDING WITH CONSTRUCTION. A NUMBER IDENTIFIES EACH PLASTIC PART FOR YOUR CONVENIENCE. PAINT SMALL PARTS ON RUNNER BEFORE REMOVING. ALLOW PAINT TO DRY THOROUGHLY BEFORE CONTINUING ASSEMBLY OF KIT. SCRAPE CHROME OR PAINT AT AREA TO BE GLUED. WASH PLASTIC IN MILD DETERGENT SOLUTION. RINSE AND LET AIR DRY FOR BETTER PAINT AND DECAL ADHESION.

FRANCAIS: EXAMINER LES SCHEMAS D'ASSEMBLAGE AVANT DE COMMENCER LA CONSTRUCTION. UN NUMERO IDENTIFIE CHAQUE PIECE DE PLASTIQUE POUR PLUS DE FACILITE. PEINDRE LES PETITES PEICES SUR LE SUPPORT AVANT DE LES ENLEVER. LAISSER LA PEINTURE SECHER COMPLETEMENT AVANT DE CONTINUER L'ASSEMBLAGE

DU KIT. GRATTER LE CHROME OU LA PEINTURE SUR LES SURFACE A COLLER. LAYER LE PLASTIQUE DANS UNE SOLUTION DE DETERGENT LEGERE, RINCER ET LAISSER SECHER A L'AIR POUR UNE MEILLEURE ADHERENCE DE LA PEINTURE ET DES DECALS.

ESPAÑOL: DIBUJOS DE ENSAMBLAJE DEBEN SER REPASADOS ANTES DE SEGUIR CON LA CONSTRUCCION. UN NUMERO IDENTIFICA CADA PARTE DEL PLASTICO PARA SU CONVENIENCIA. PINTA PARTES PEQUENAS DEL KIT ANTES DE QUITARLAS. DEJE SECAR BIEN LA PINTURA ANTES DE SEGUIR EL ENSAMBLAJE. RASPE EL CROMO O LA PINTURA DEL SITIO ANTES DE SER PEGADO. LAVE EL PLASTICO EN UNA SOLUCION SUAVE DETERGENTE, ENJUAGUE, Y DEJE SECAR EN EL AIRE PARA MEJOR ADHESION DE LA PINTURA Y CALCOMANIA.



GLUE
COLLE
PEGA



NO GLUE REQUIRED
LA COLLE N'EST PAS NECESSAIRE
NO NECESITA PEGA



DO IT THIS MANY TIMES
LE FAIRE CE NOMBRE DE FOIS
HAGALO ESTA CANTIDAD DE VECES



OPTIONAL
FACULTATIF
OPCIONAL



APPLY DECALS
COLLER LES DECALCOMANIES
APLICAR CALCAS



SHOWN ASSEMBLED
VU ASSEMBLE
MOSTRADO ARMADO

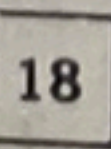

CLEAR
TRANSPARENT
TRANSPARENTE

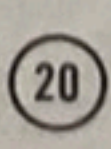

LIGHT OLIVE
OLIVE CLAIR
OLIVA CLARO

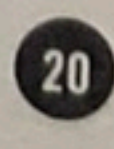

SILVER
ARGENT
PLATA

A MATT BLACK	NOIR MAT	NEGRO MATE	G METALLIC GRAY	GRIS METALLISE	GRIS METALICO
B WHITE	BLANC	BLANCO	H MATT WHITE	BLANC MAT	BLANCO MATE
C FLESH	CHAIR	PIEL	I MATT LIGHT GRAY	GRIS CLAIR MAT	GRIS PALIDO MATE
D OLIVE GREEN	VERT OLIVE	VERDE OLIVA	J MATT OLIVE GREEN	VERT OLIVE MAT	VERDE OLIVA MATE
E MEDIUM GRAY	GRIS MOYEN	GRIS MEDIO	K LIGHT GRAY	GRIS CLAIR	GRIS CLARO
F SILVER	ARGENT	PLATA	L BLUE	BLEU	AZUL

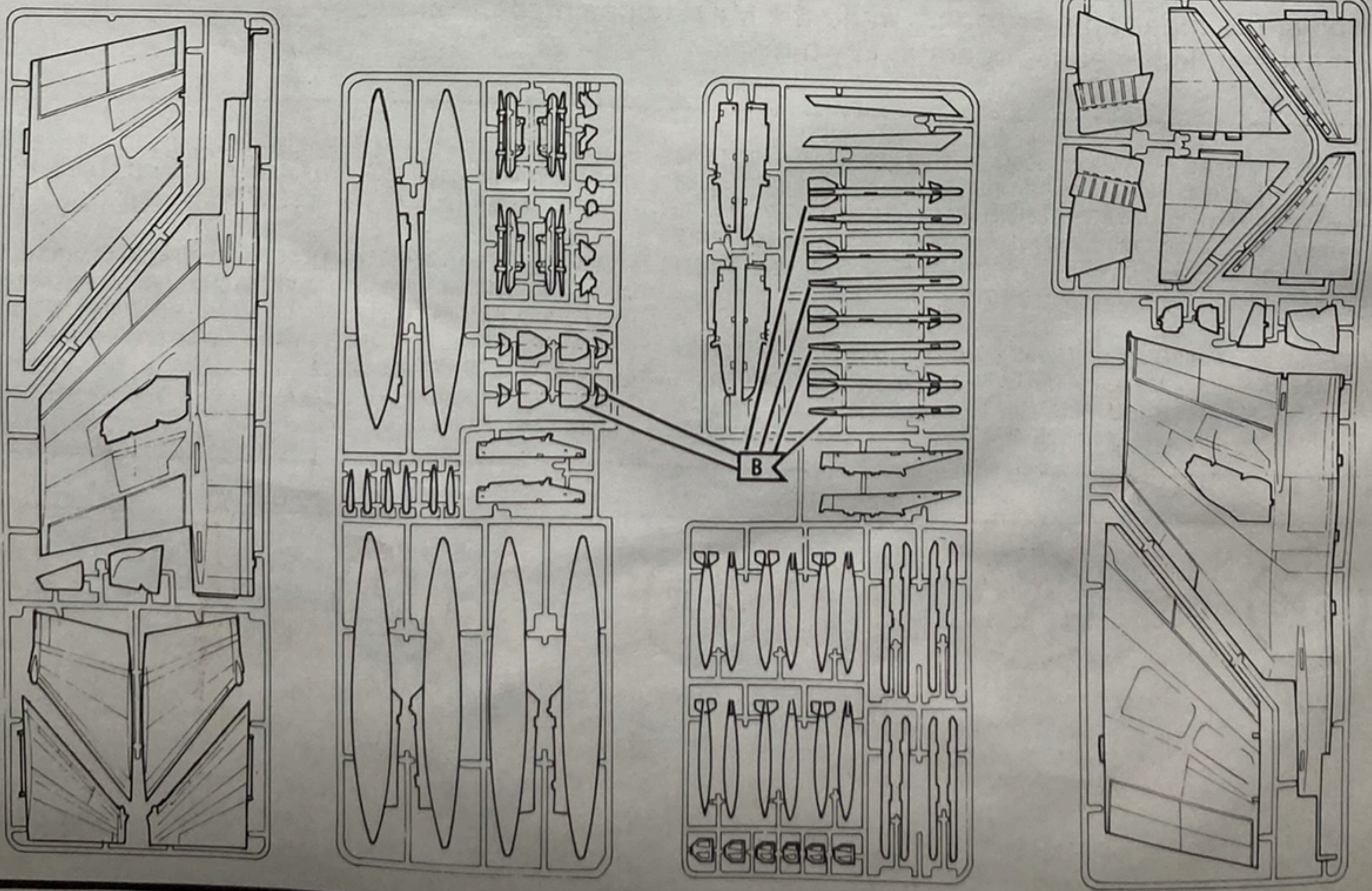
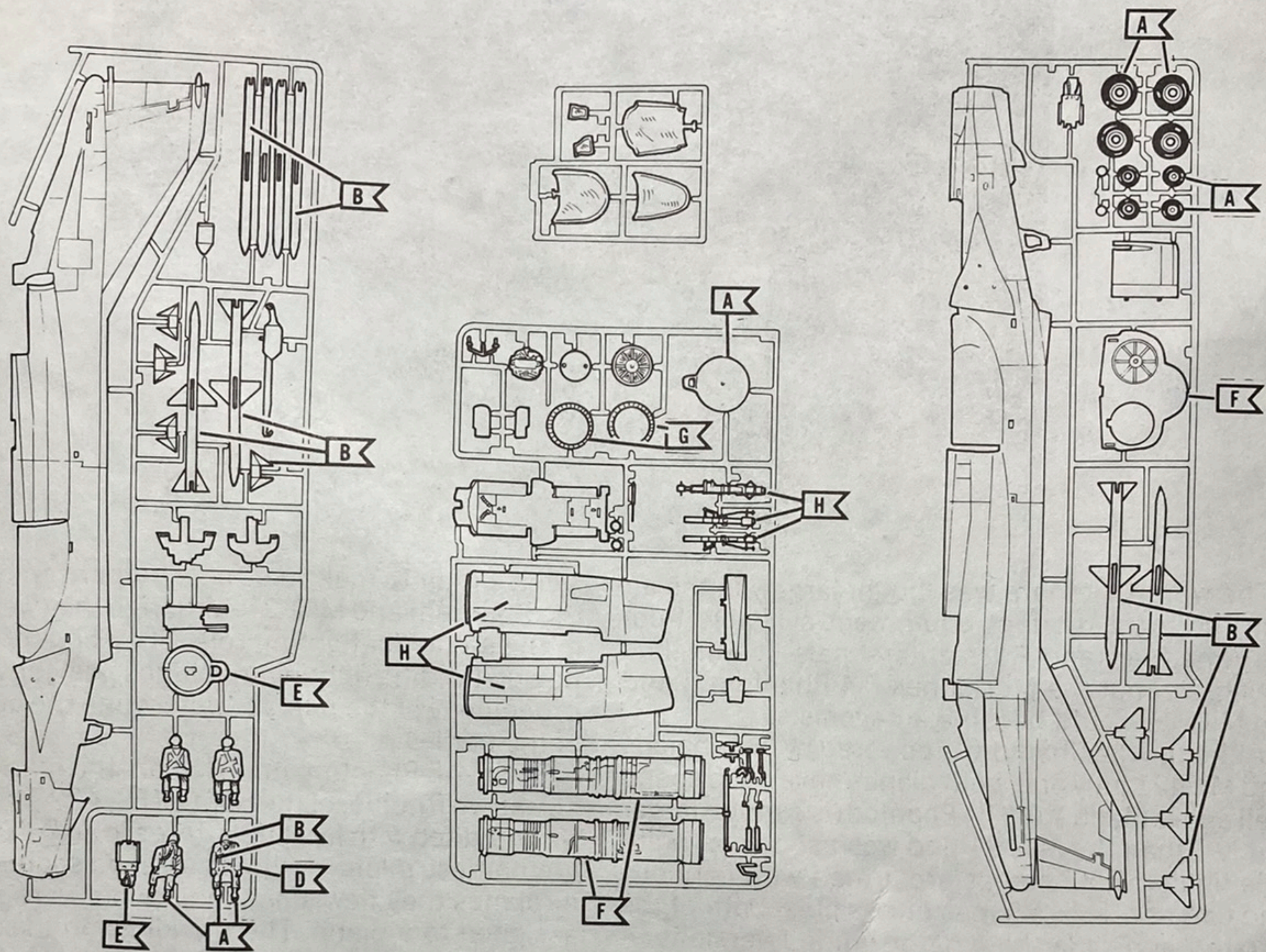

1

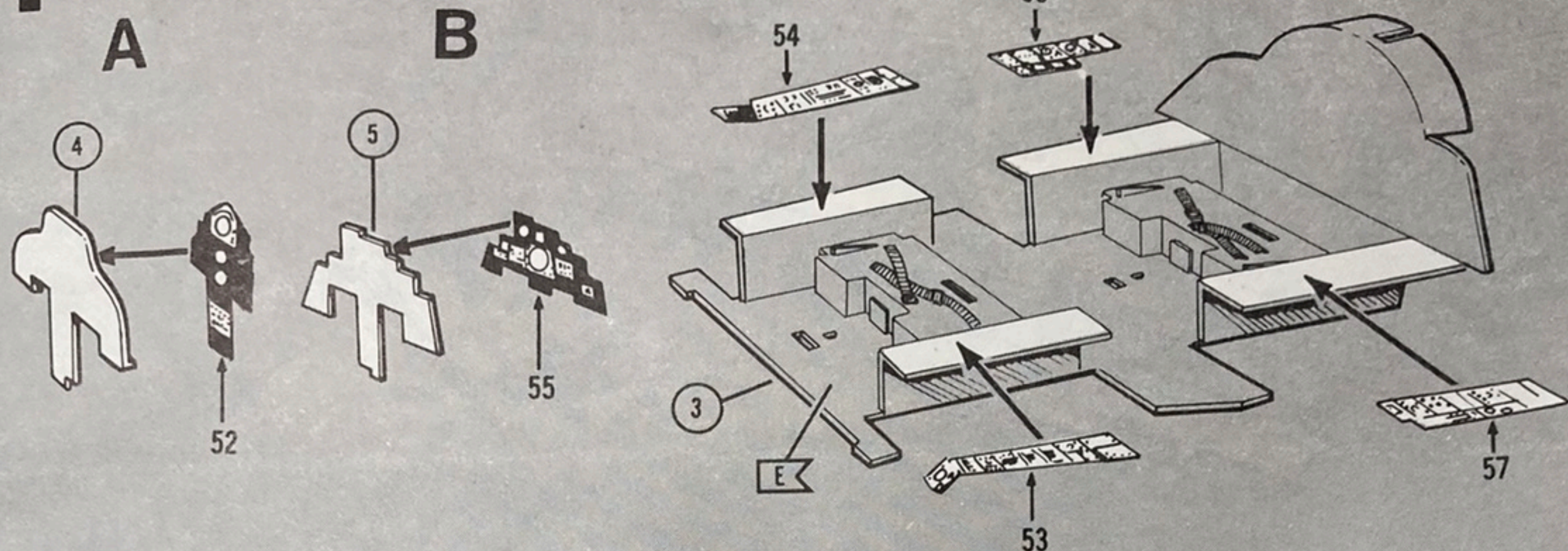

- 3 COCKPIT FLOOR
- 4 PILOT'S INSTRUMENT PANEL
- 5 RADAR OPERATOR'S INSTRUMENT PANEL



52 → (4) 55 → (5) 53 54 56 57 → (3)

2

2 CONTROL COLUMN (2 PARTS)

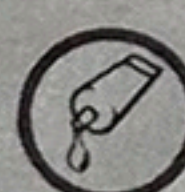
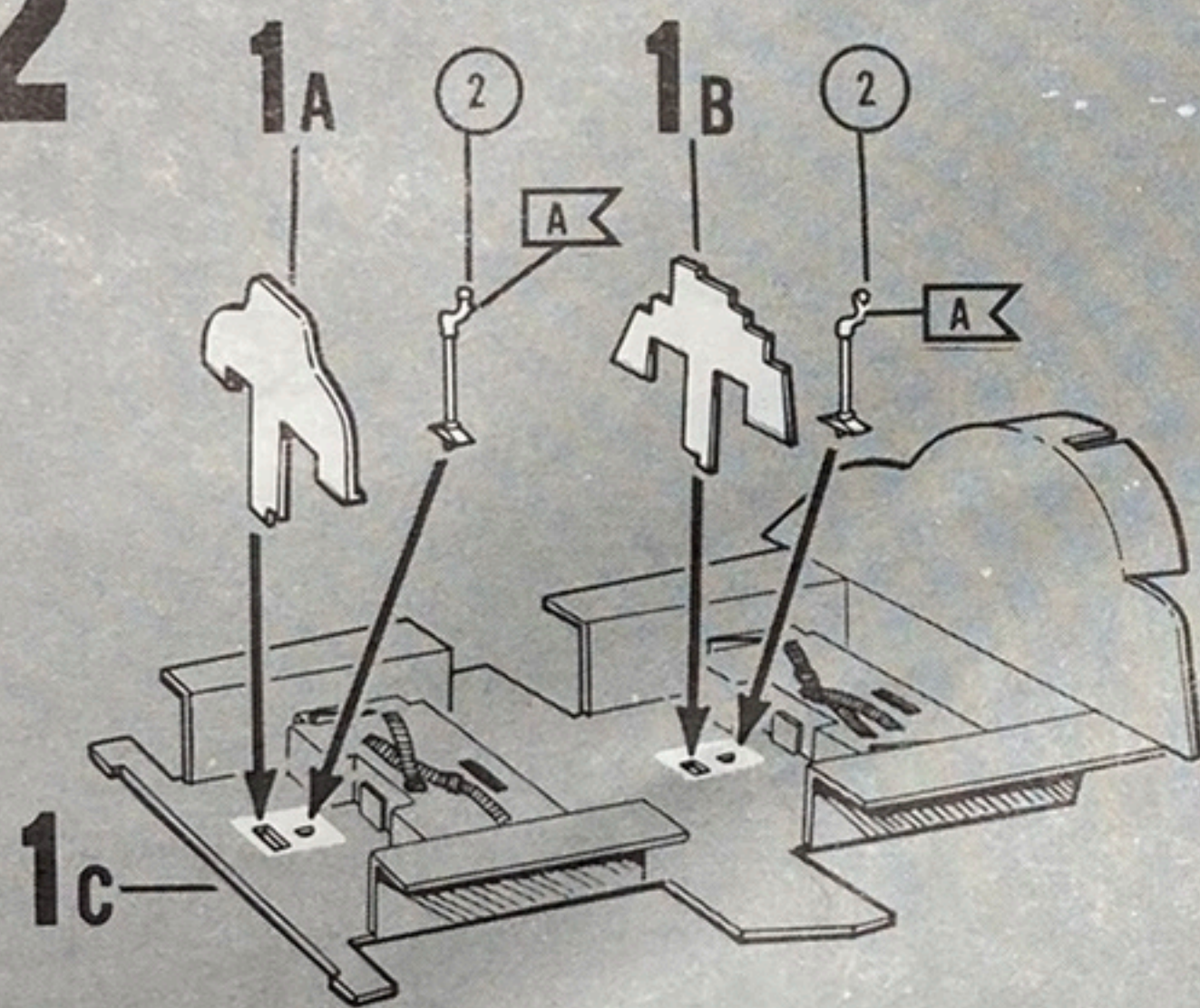

(2X) 2 → 1C (1) 1A-B → 1C

3

6 CREW FIGURE — FRONT HALF (2 PARTS)
7 CREW FIGURE — BACK HALF (2 PARTS)

(2X)

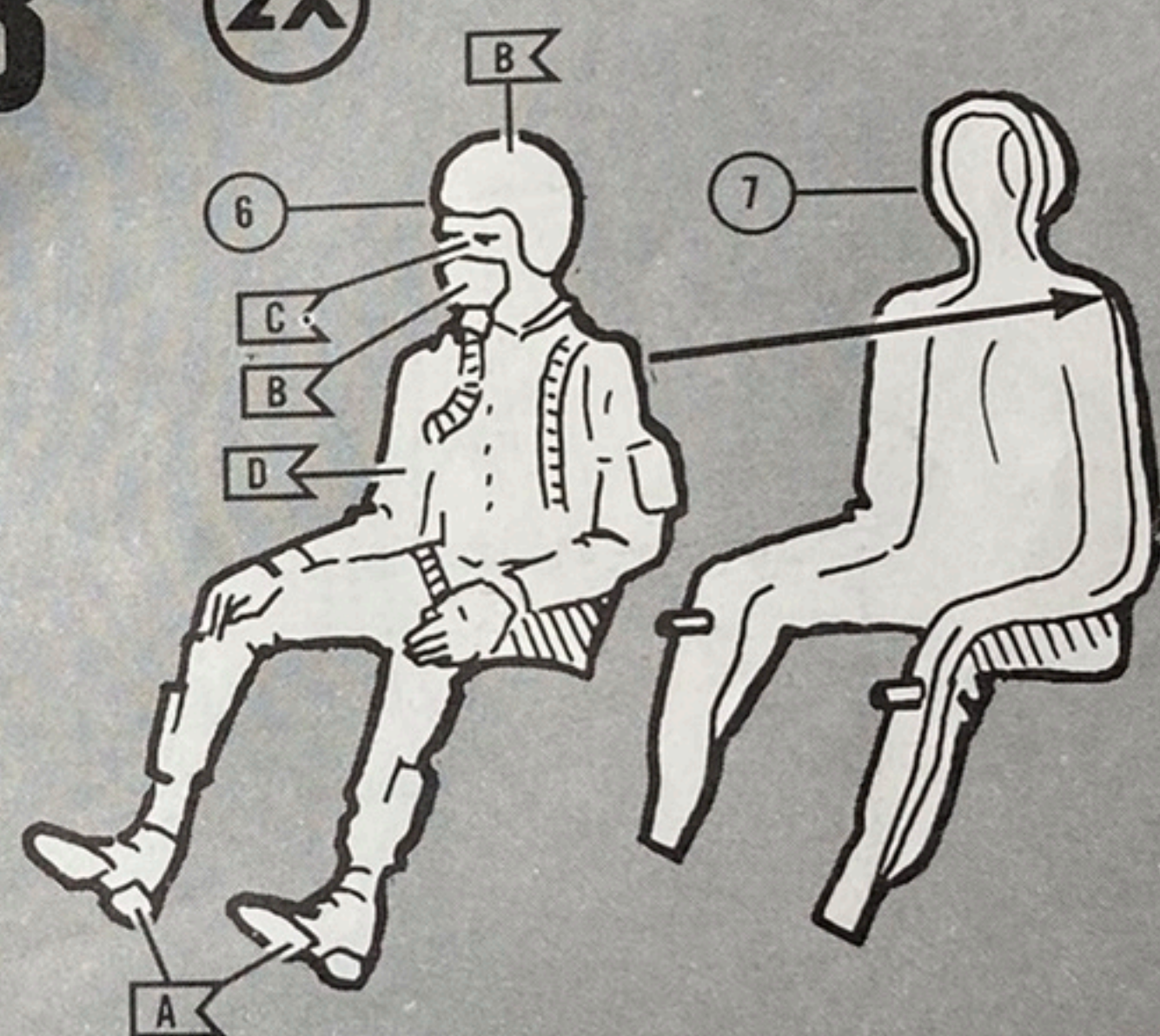

(6) → (7)

4

1 SEAT BACK (2 PARTS)

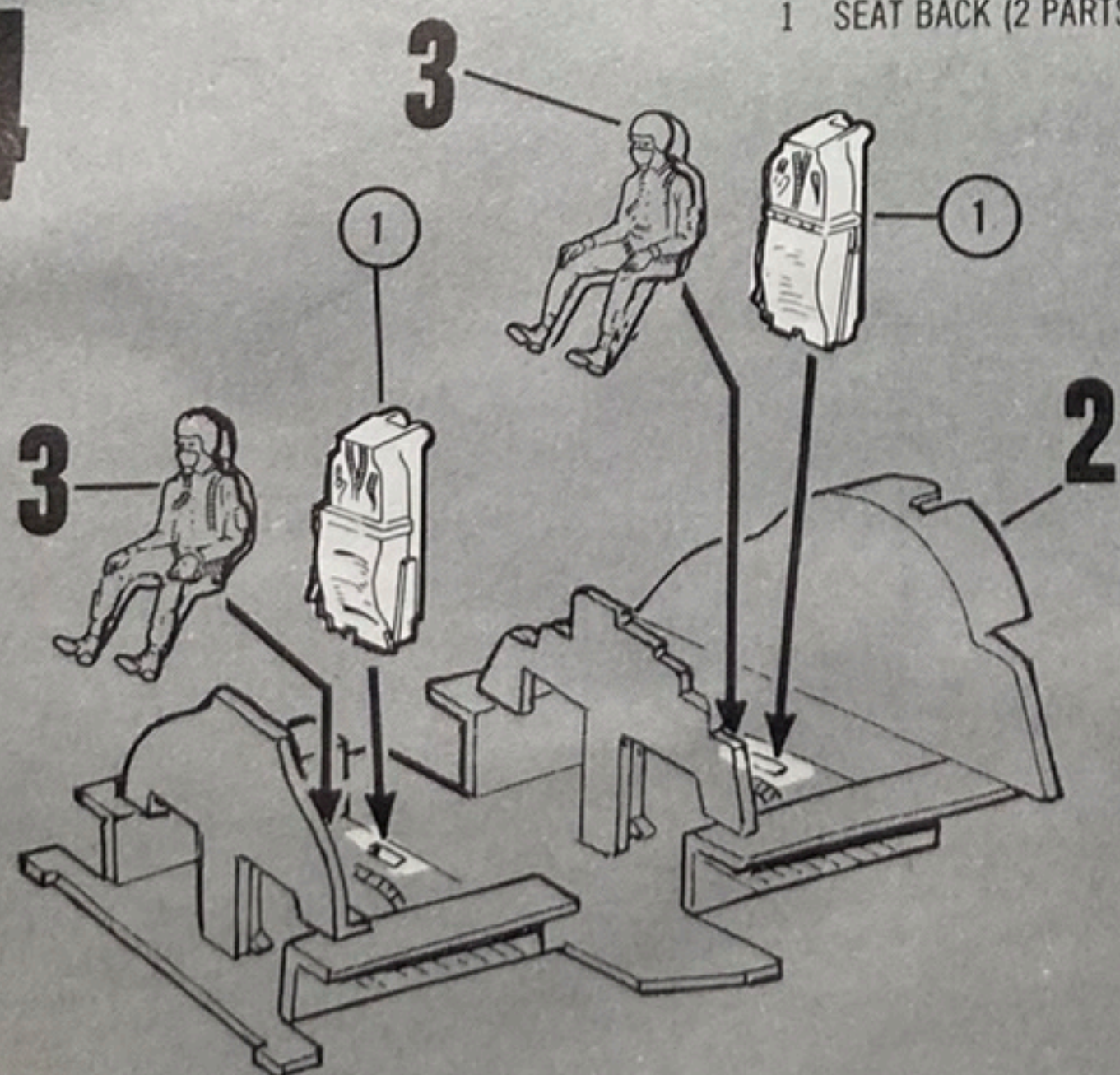

(2X) 1 → 2 (3) 3 → 2

5

8 LEFT ENGINE — LEFT HALF
9 LEFT ENGINE — RIGHT HALF
10 LEFT ENGINE INTAKE
11 ENGINE EXHAUST CONE

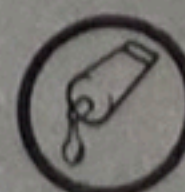
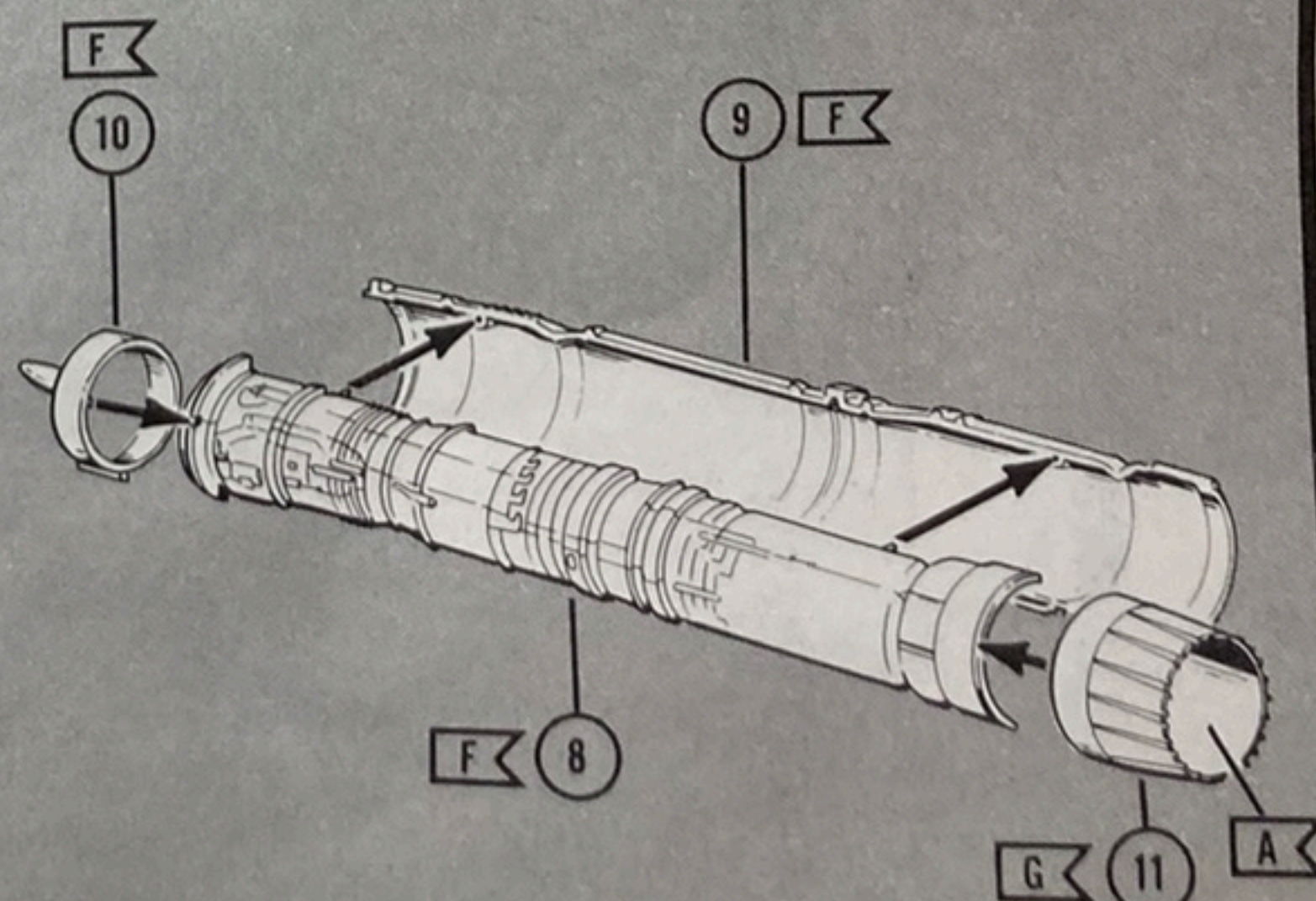

(8) → (9) (10) (11) → (8) (9)

6

Remove
Oter
Rimuovere

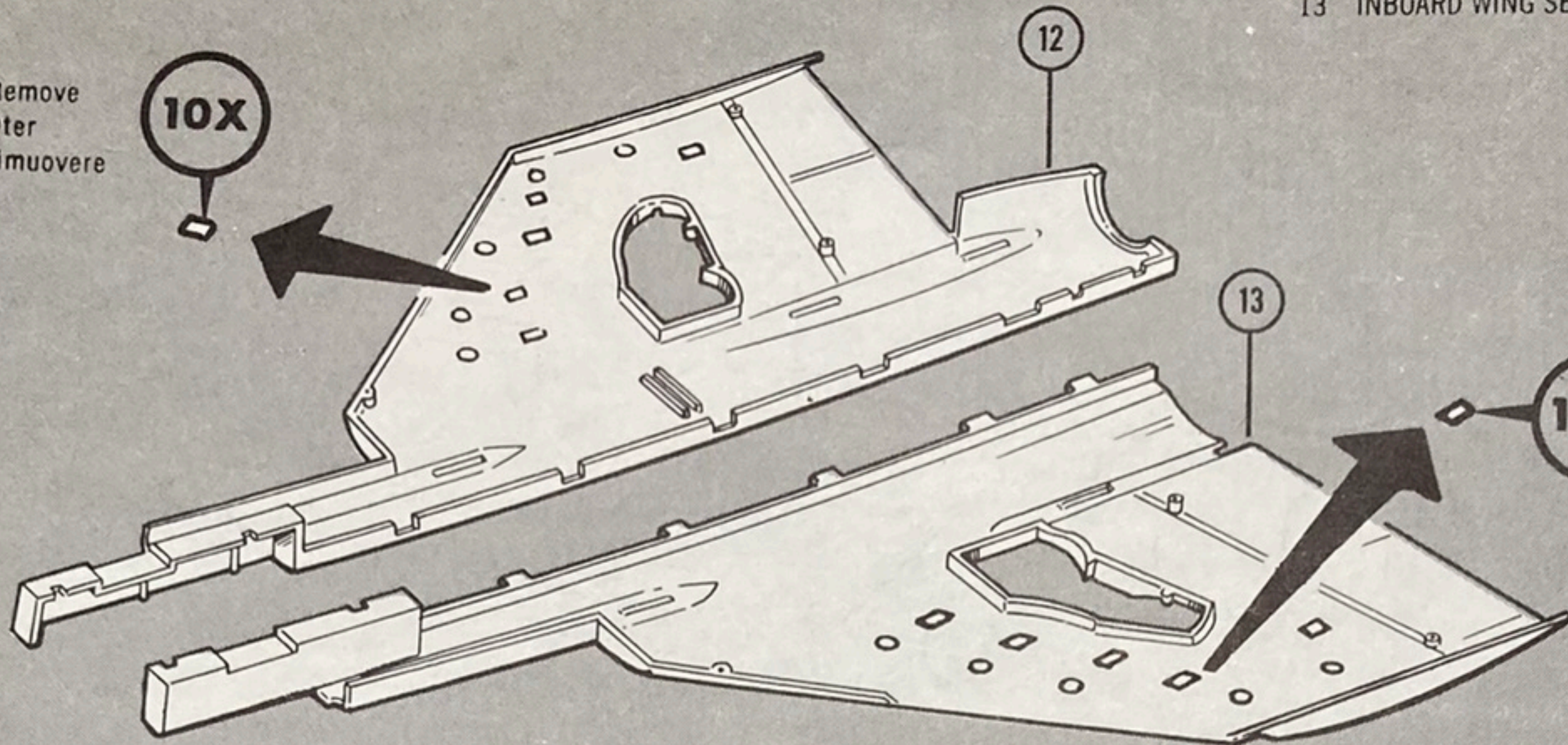

- 12 INBOARD WING SECTION — RIGHT BOTTOM
- 13 INBOARD WING SECTION — LEFT BOTTOM

10X

Remove
Oter
Rimuovere

7

A

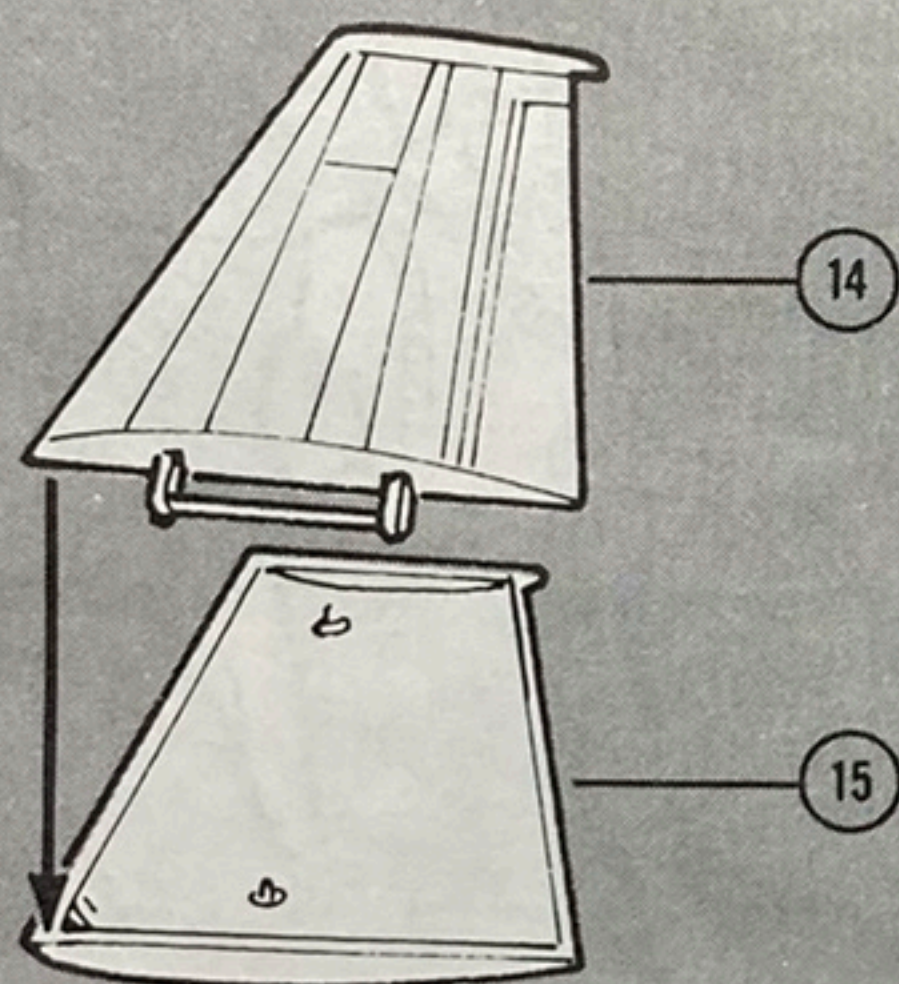

- 14 OUTBOARD WING SECTION — RIGHT TOP
- 15 OUTBOARD WING SECTION — RIGHT BOTTOM

- 17 OUTBOARD WING SECTION — LEFT TOP
- 18 OUTBOARD WING SECTION — LEFT BOTTOM

B

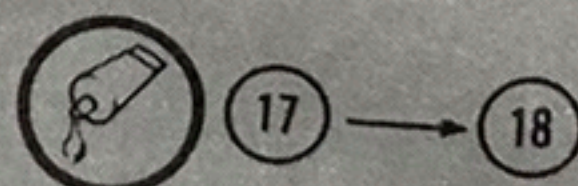
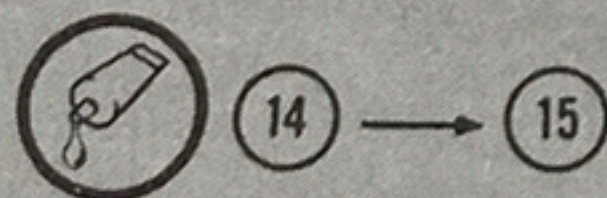
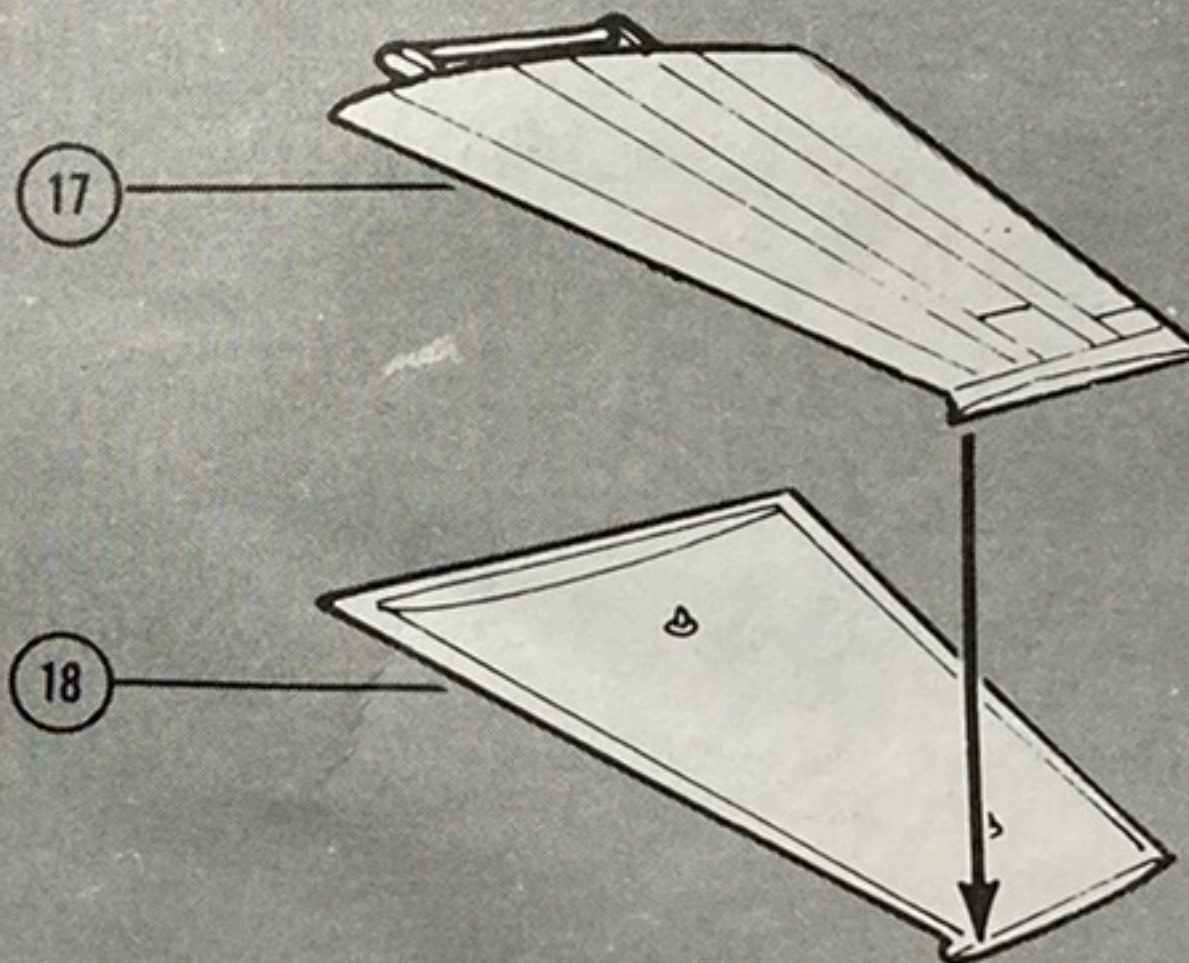

8

A

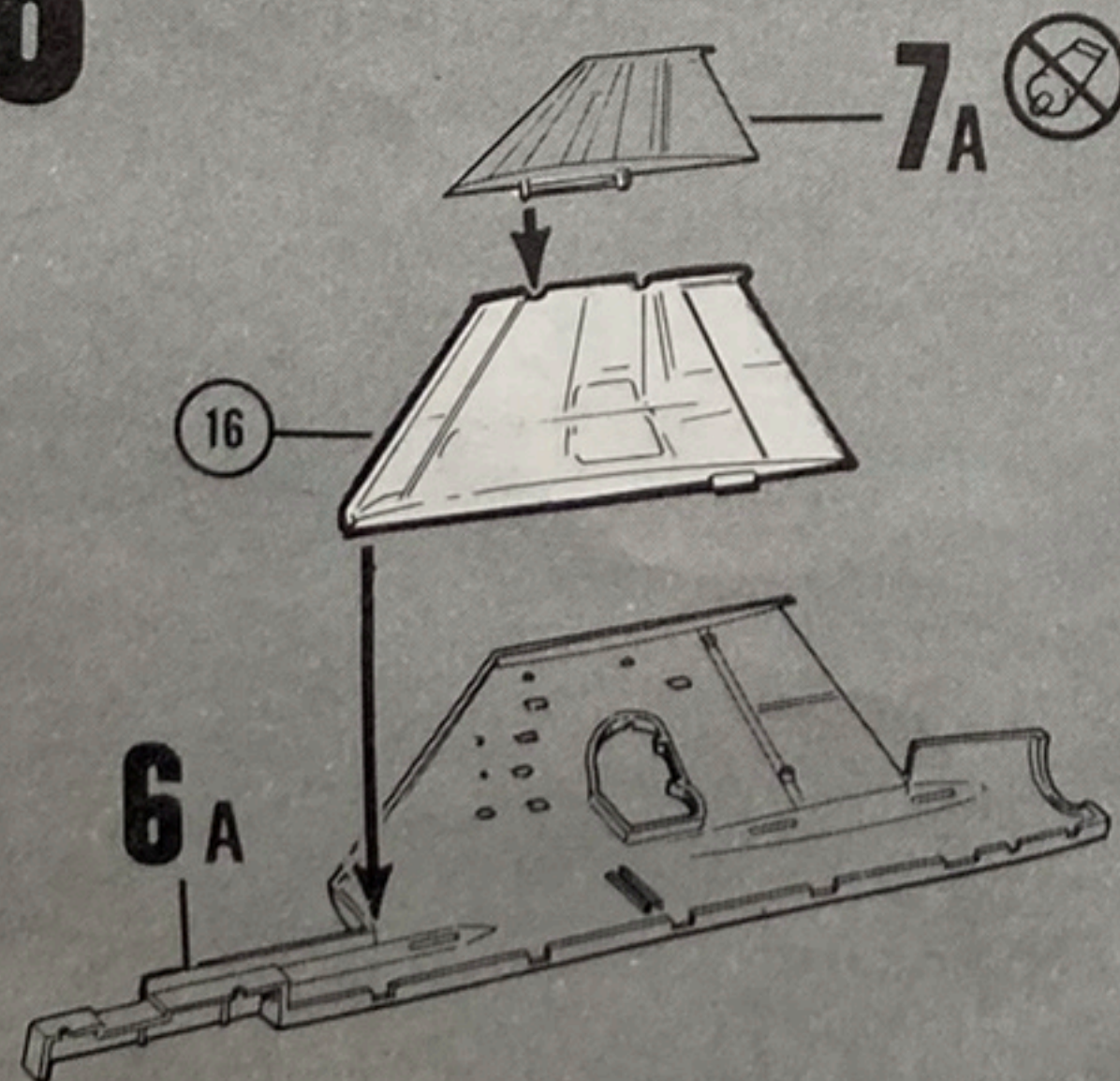

- 16 INBOARD WING SECTION — RIGHT TOP
- 19 INBOARD WING SECTION — LEFT TOP

B

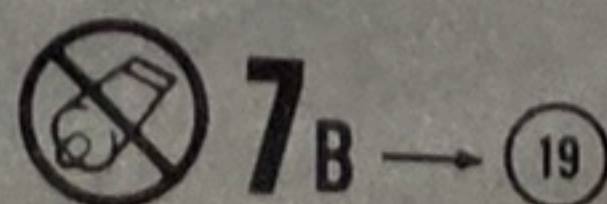
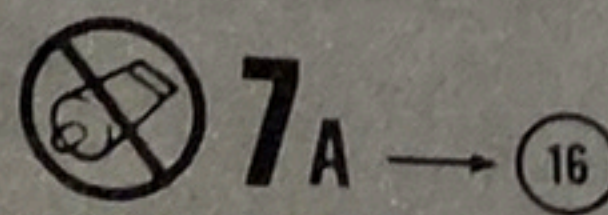
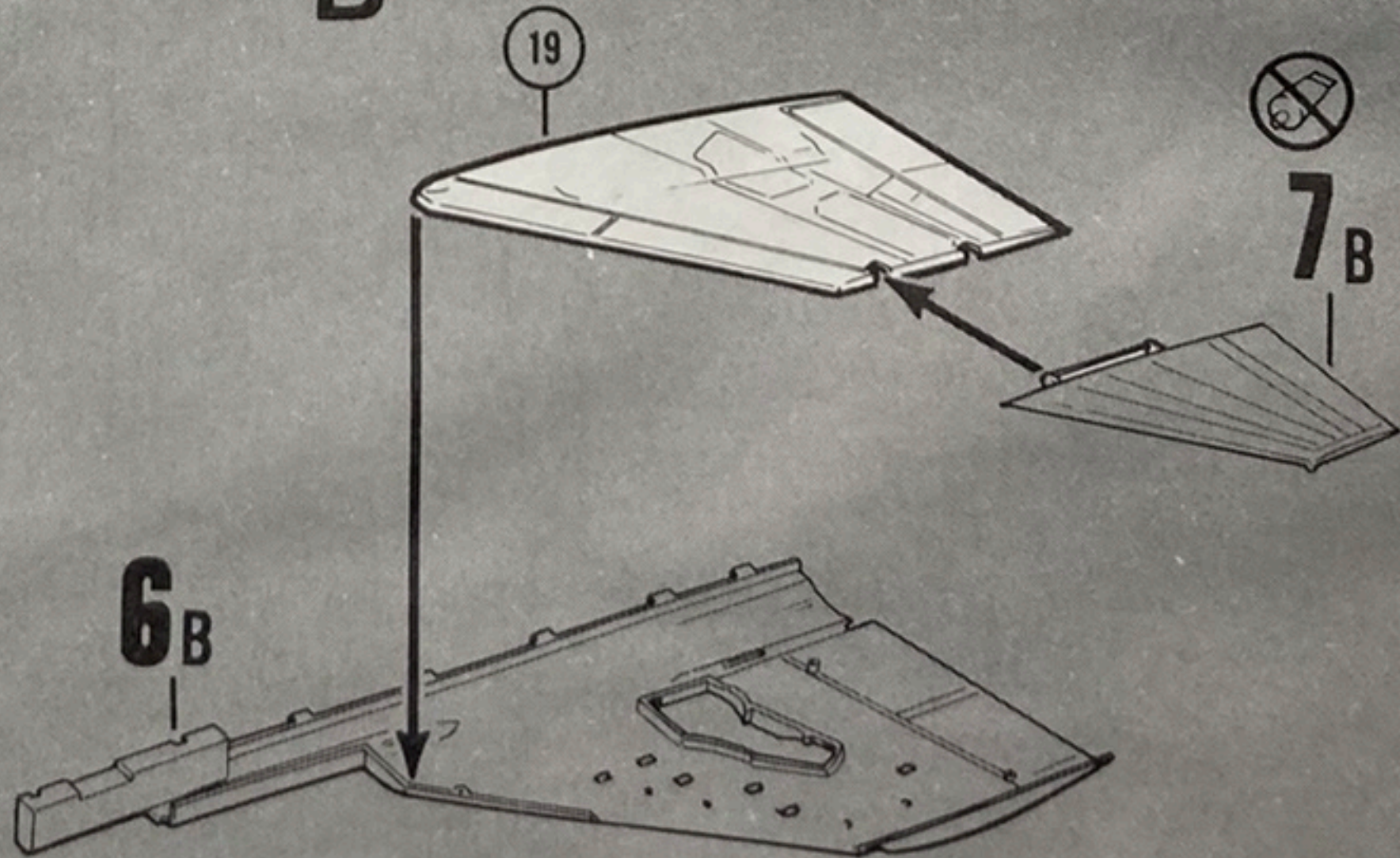

9

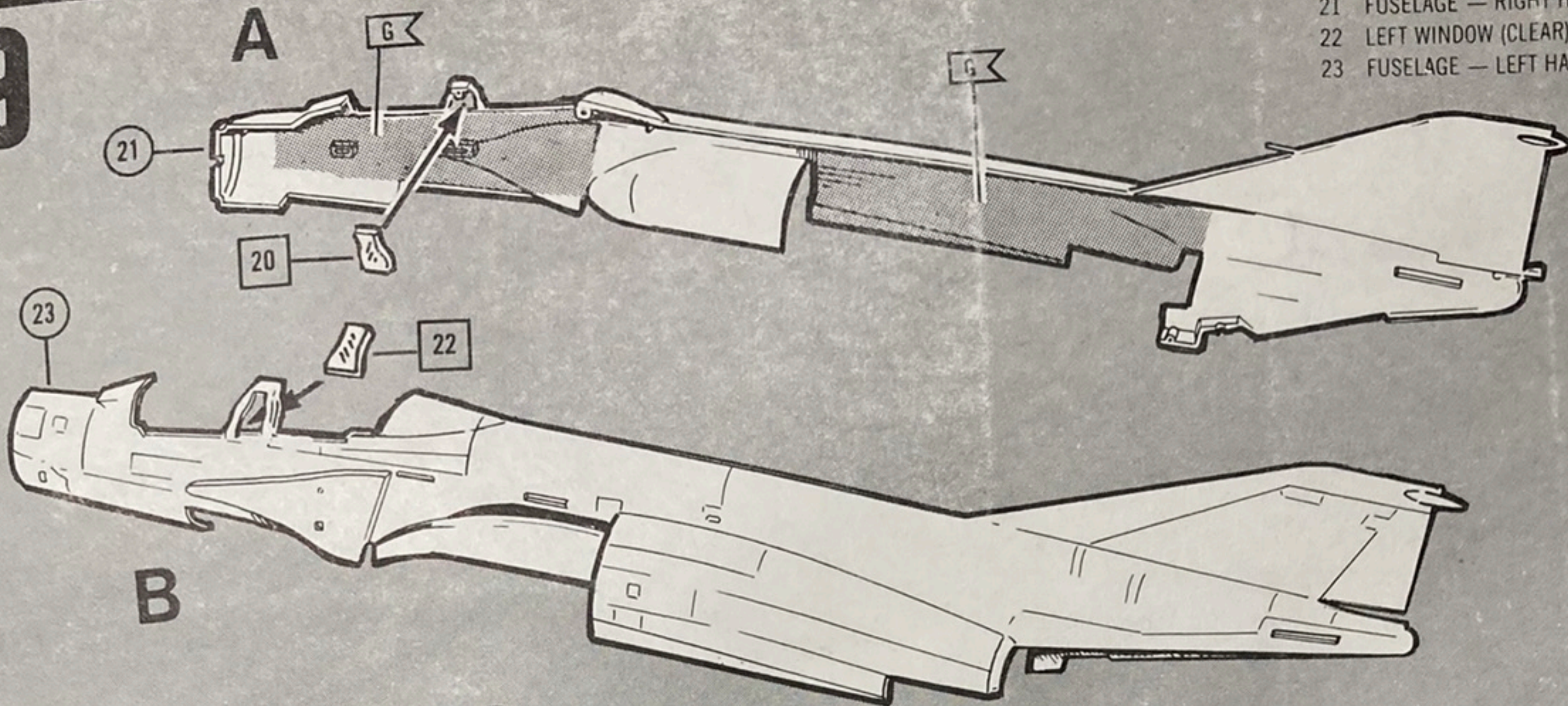

- 20 RIGHT WINDOW (CLEAR)
- 21 FUSELAGE — RIGHT HALF
- 22 LEFT WINDOW (CLEAR)
- 23 FUSELAGE — LEFT HALF



10

- 24 ARRESTING HOOK — LEFT HALF
- 25 ARRESTING HOOK — RIGHT HALF

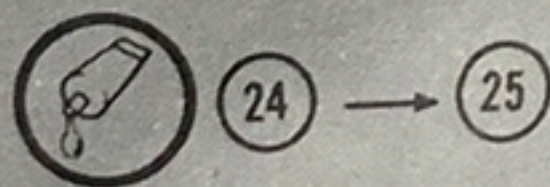
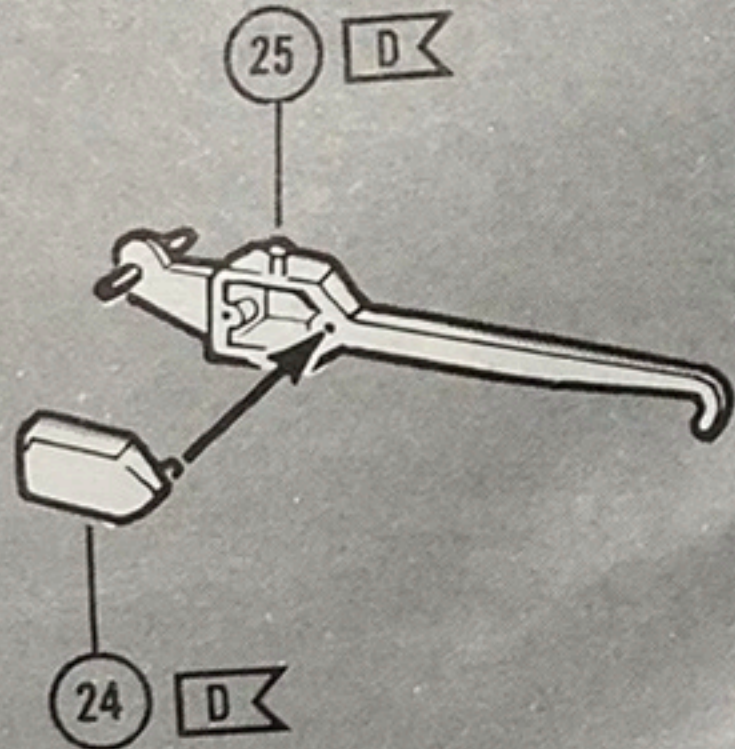

11

- 26 PILOT'S CANOPY (CLEAR)
- 27 RADAR OPERATOR'S CANOPY (CLEAR)
- 28 WINDSHIELD (CLEAR)

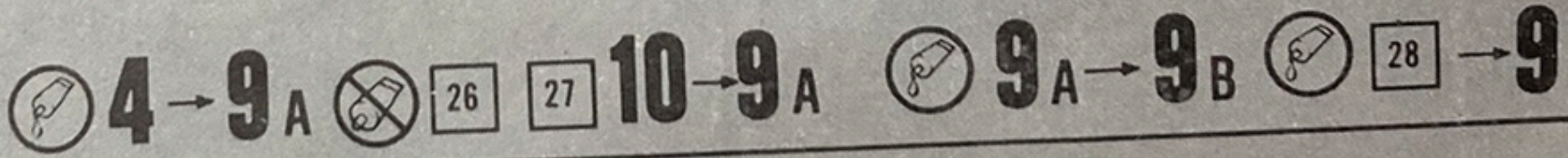
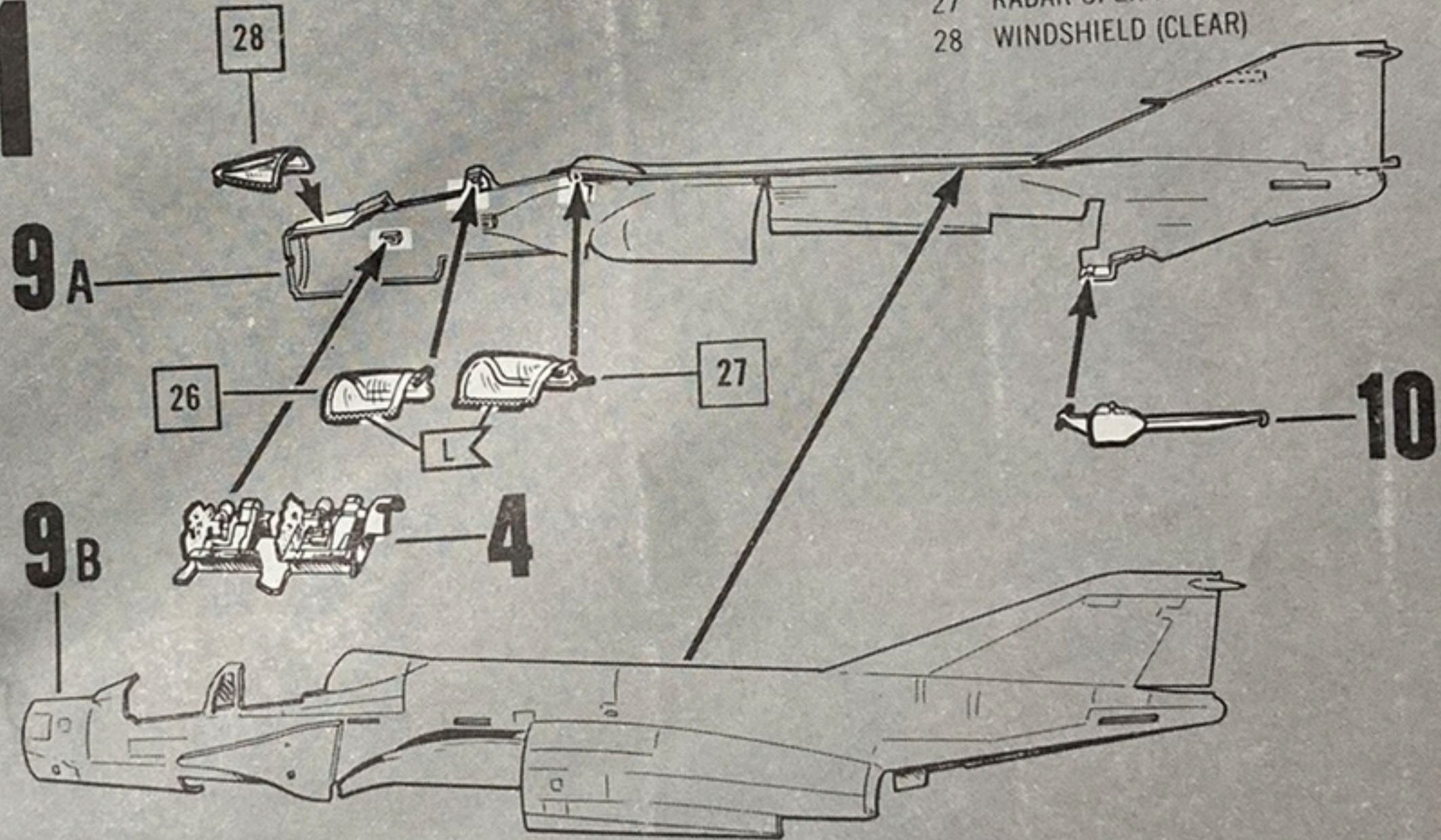

12

- 31 PITOT HEAD (2 PARTS)
- 32 AIR INTAKE DUCT FAIRING — RIGHT
- 33 AIR INTAKE DUCT FAIRING — LEFT

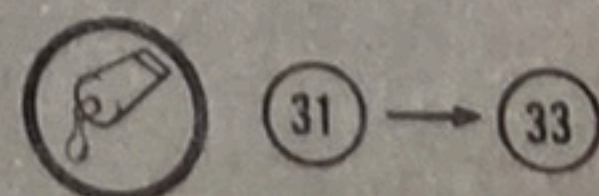
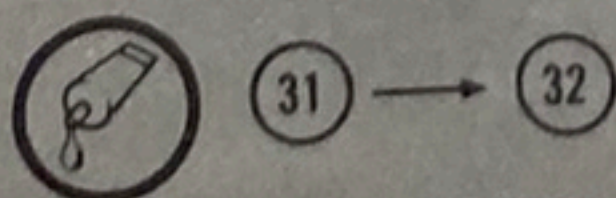
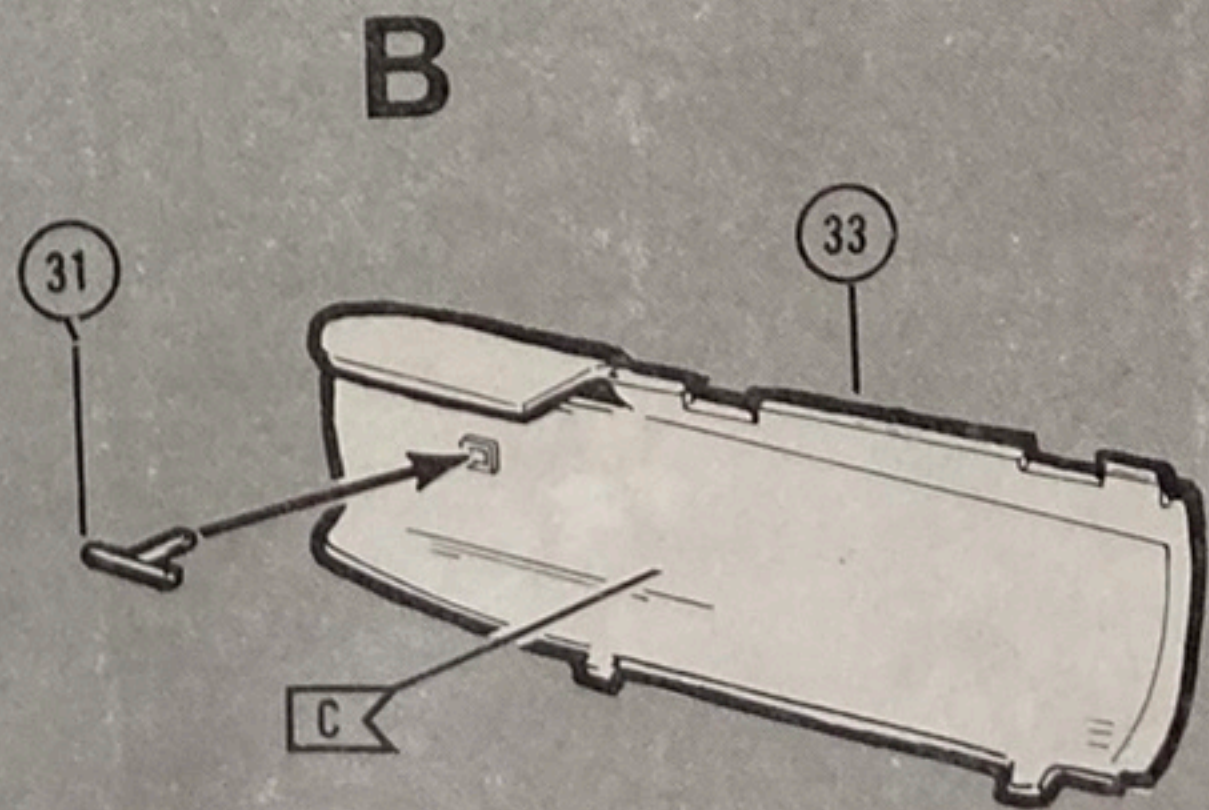
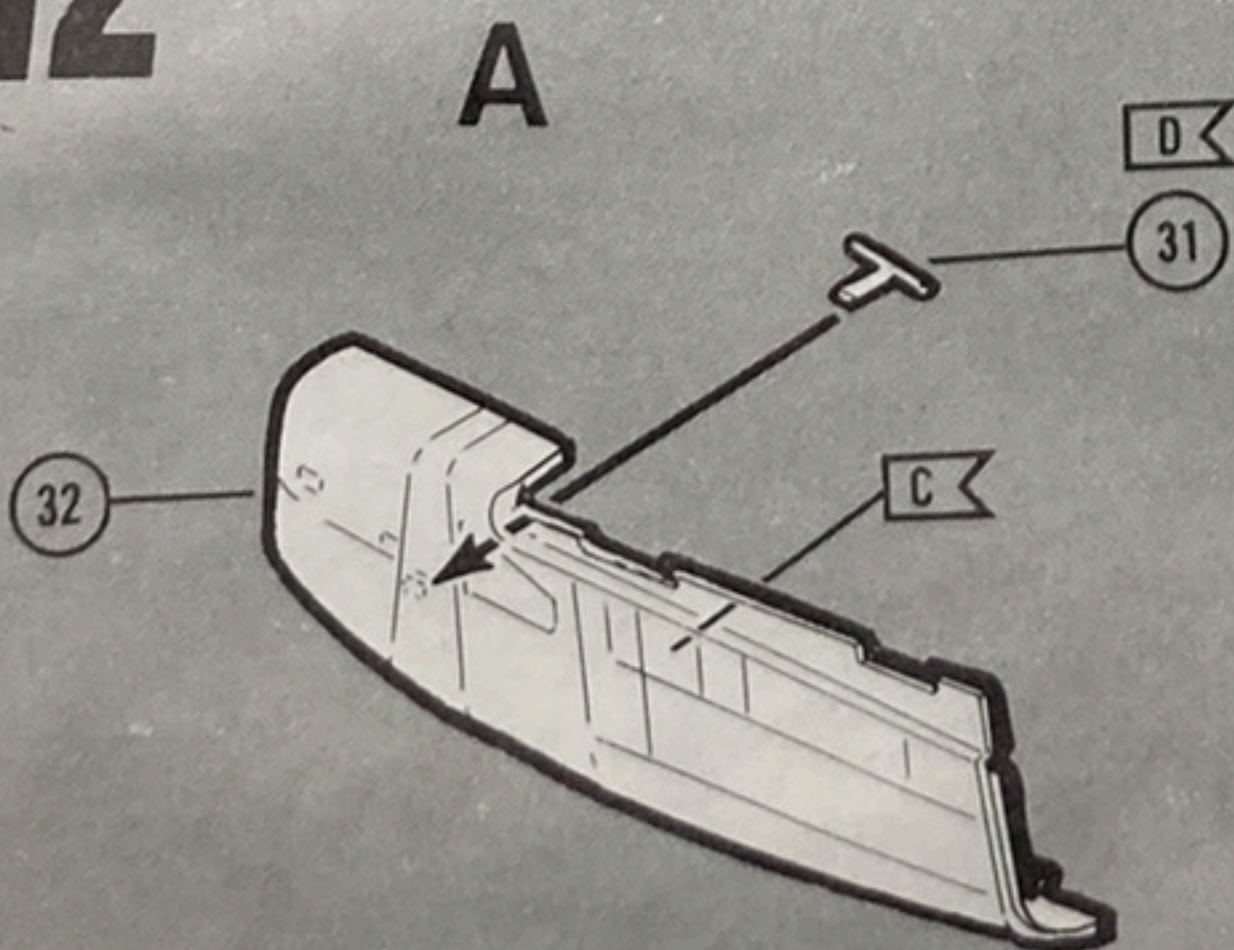

13

- 29 AIR INTAKE RAMP — RIGHT
- 30 AIR INTAKE RAMP — LEFT
- 34 FUSELAGE BULKHEAD

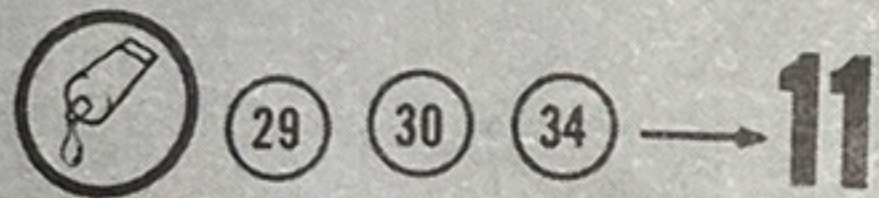
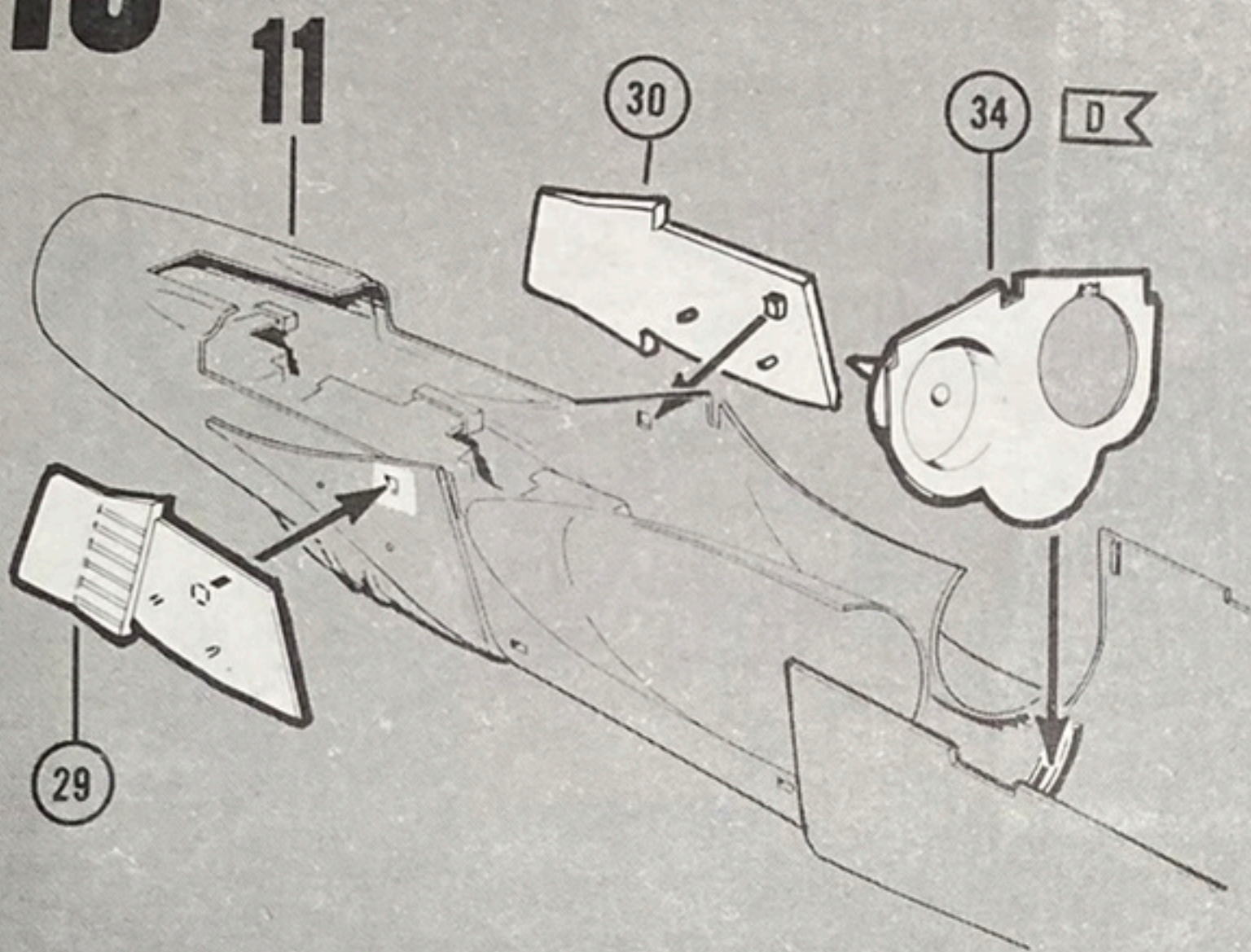

14

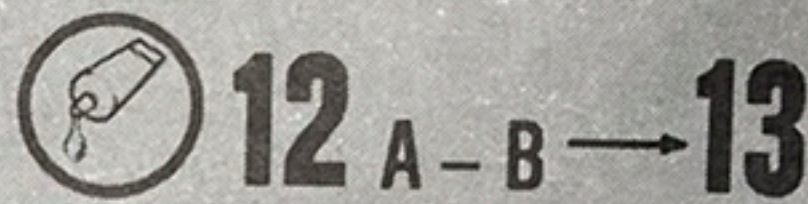
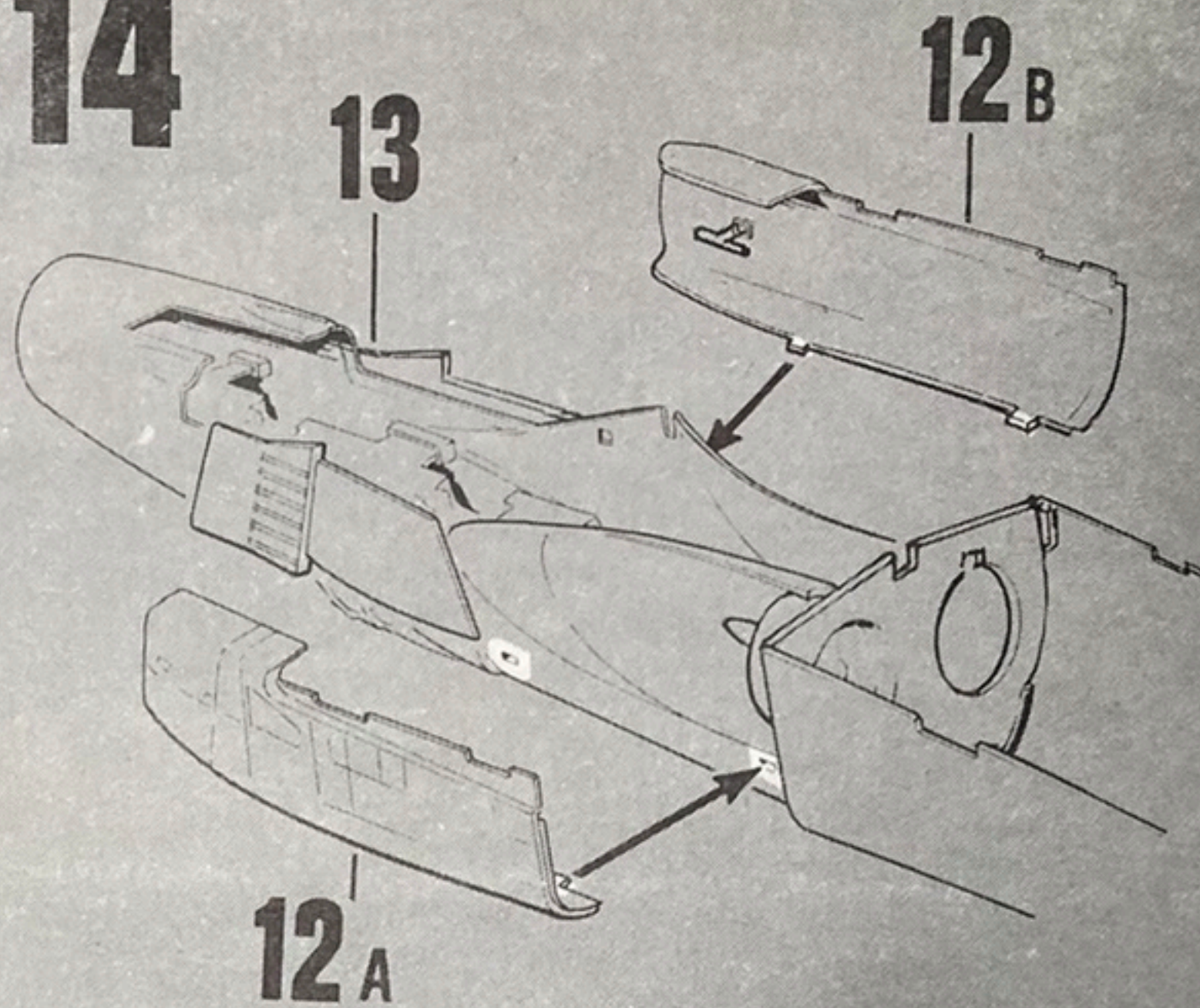

15

A

- 35 MAIN WHEEL — OUTSIDE HALF (2 PARTS)
- 36 MAIN WHEEL — INSIDE HALF (2 PARTS)
- 37 MAIN WHEEL RETAINER (2 PARTS)
- 38 LEFT MAIN GEAR STRUT
- 39 RIGHT MAIN GEAR STRUT
- 40 LEFT MAIN GEAR STRUT DOOR — CENTER
- 41 RIGHT MAIN GEAR STRUT DOOR — CENTER

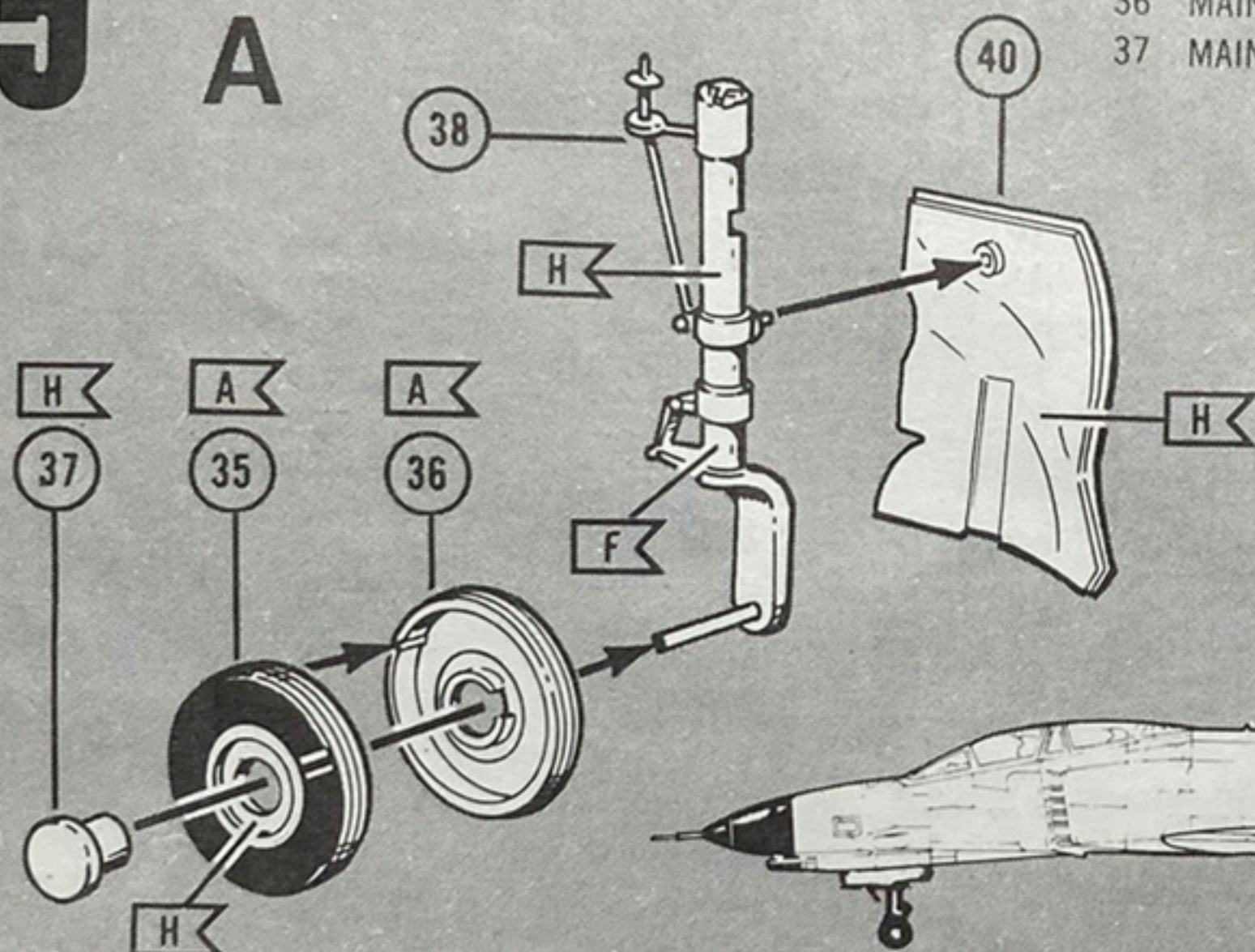

B

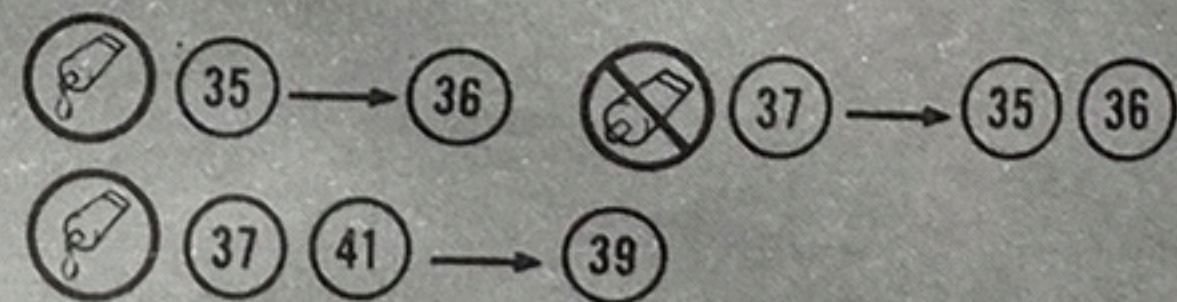
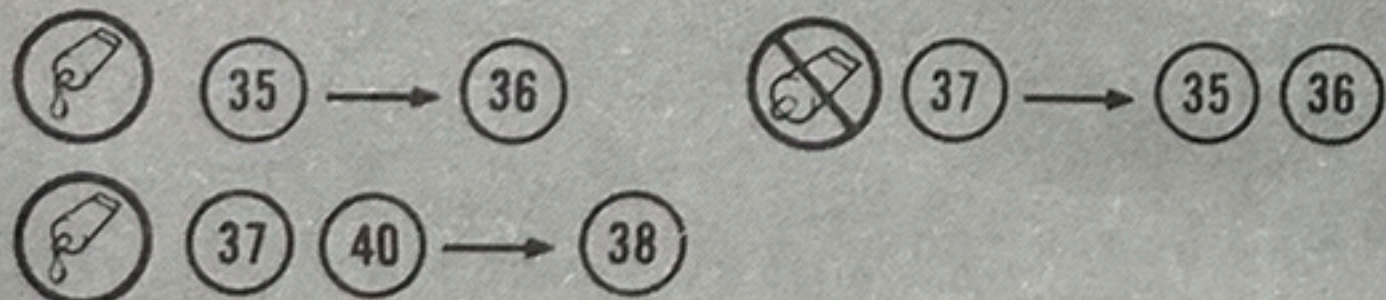
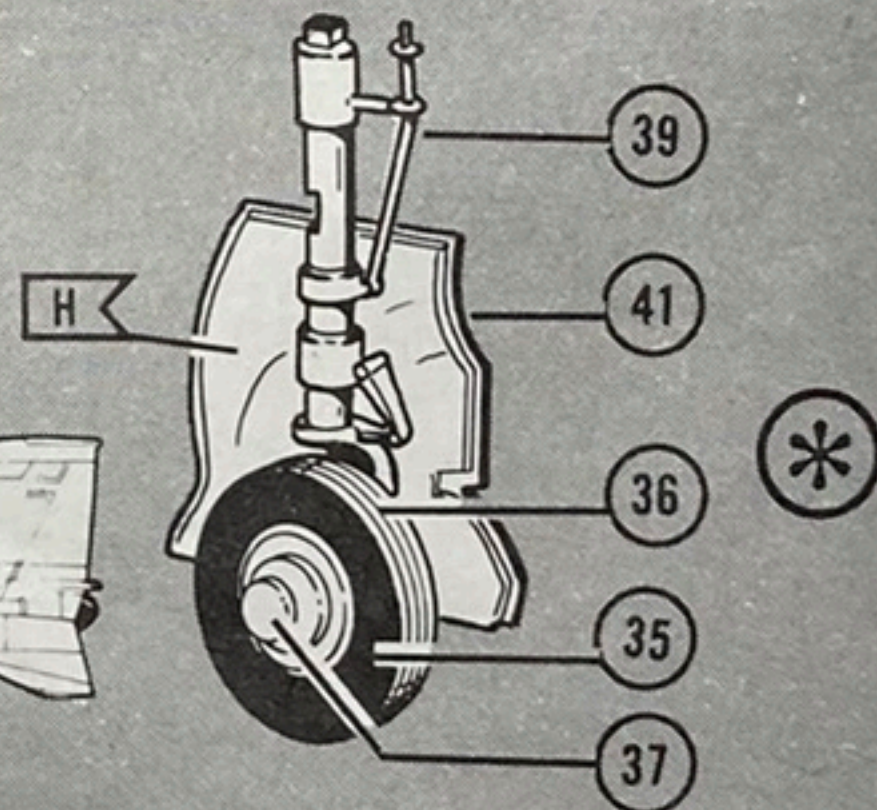

16

- 42 NOSE WHEEL RETAINER (2 PARTS)
- 43 NOSE WHEEL — INSIDE HALF (2 PARTS)
- 44 NOSE GEAR STRUT
- 45 NOSE WHEEL — OUTSIDE HALF (2 PARTS)
- 46 NOSE GEAR YOKE

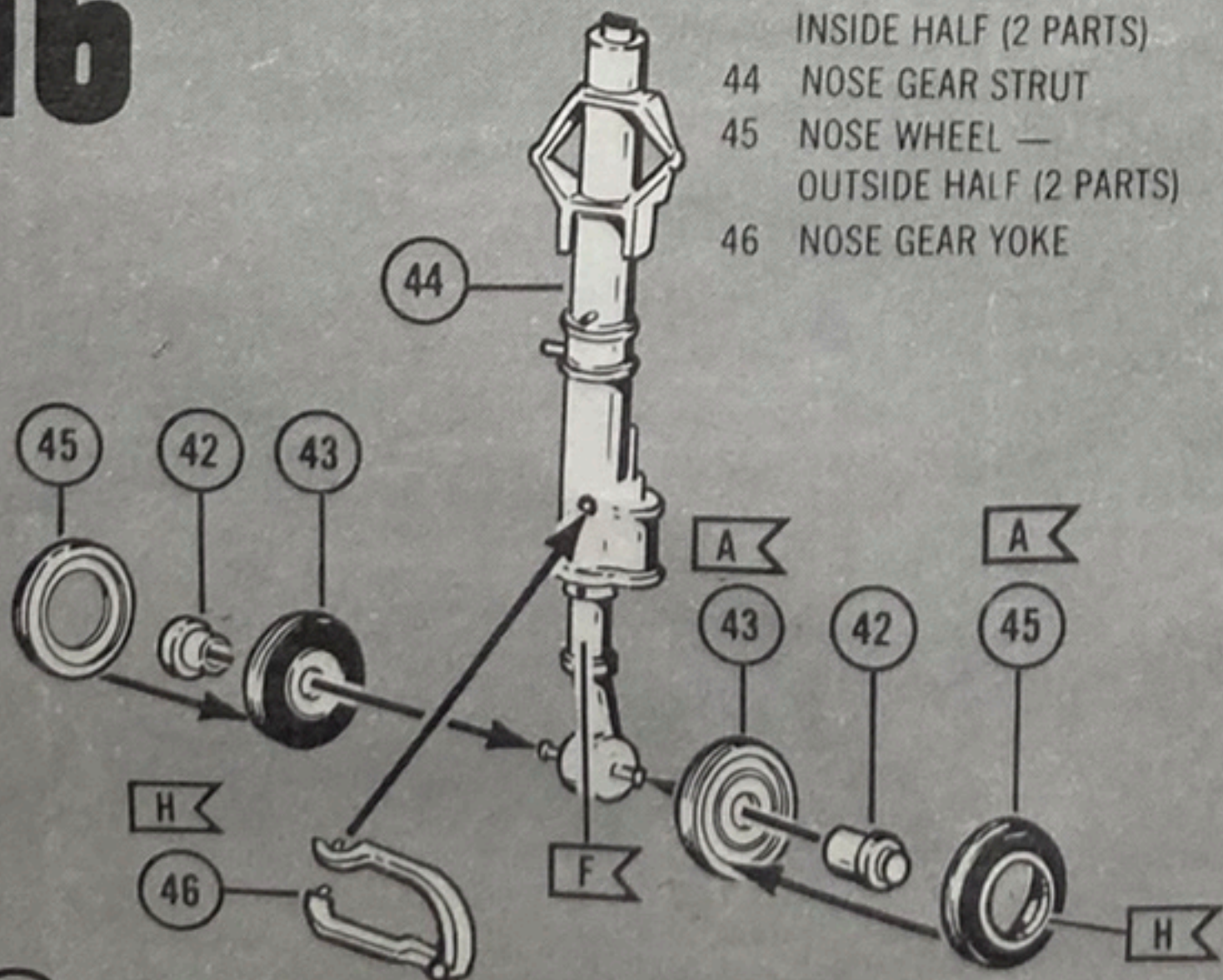

17

4X

- 48 MISSILE BODY — LEFT HALF (4 PARTS)
- 49 MISSILE BODY — RIGHT HALF (4 PARTS)
- 50 MISSILE CENTER FIN (4 PARTS)
- 51 MISSILE TAIL FIN (4 PARTS)

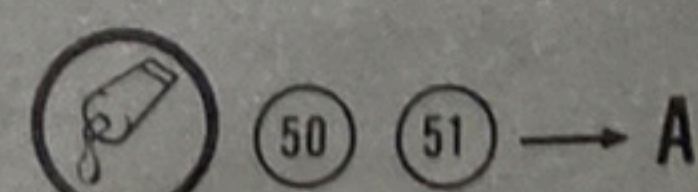
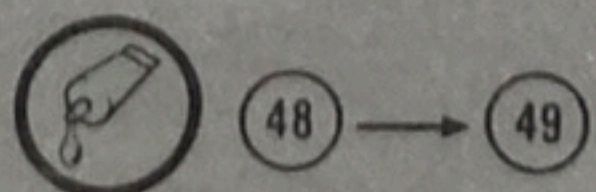
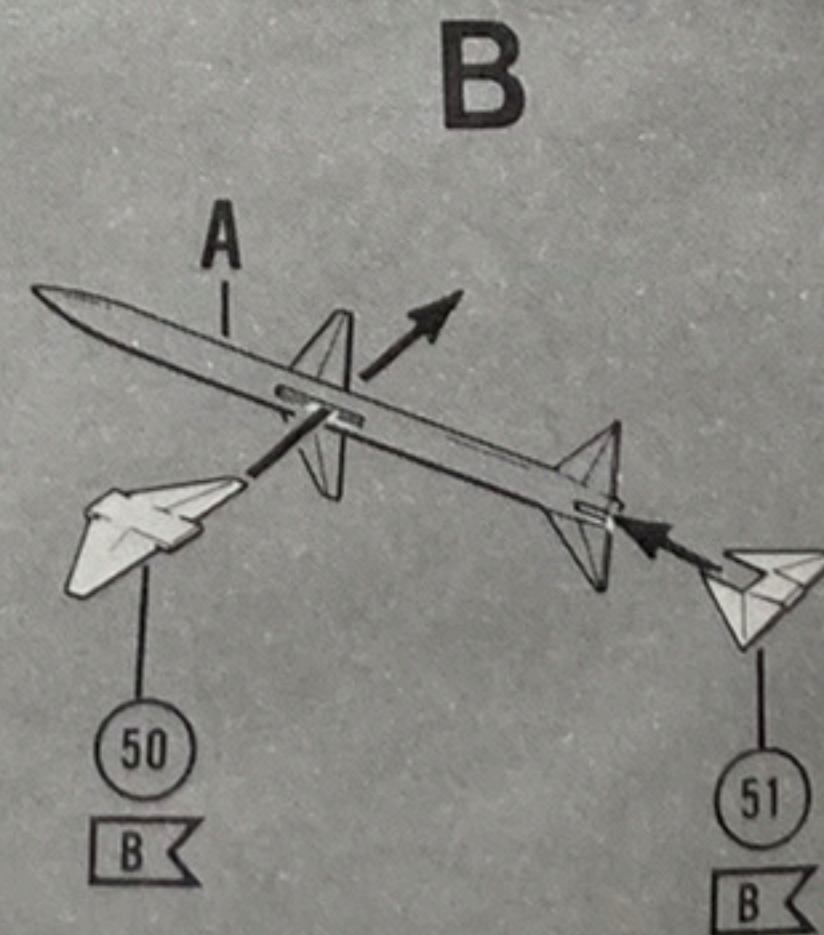
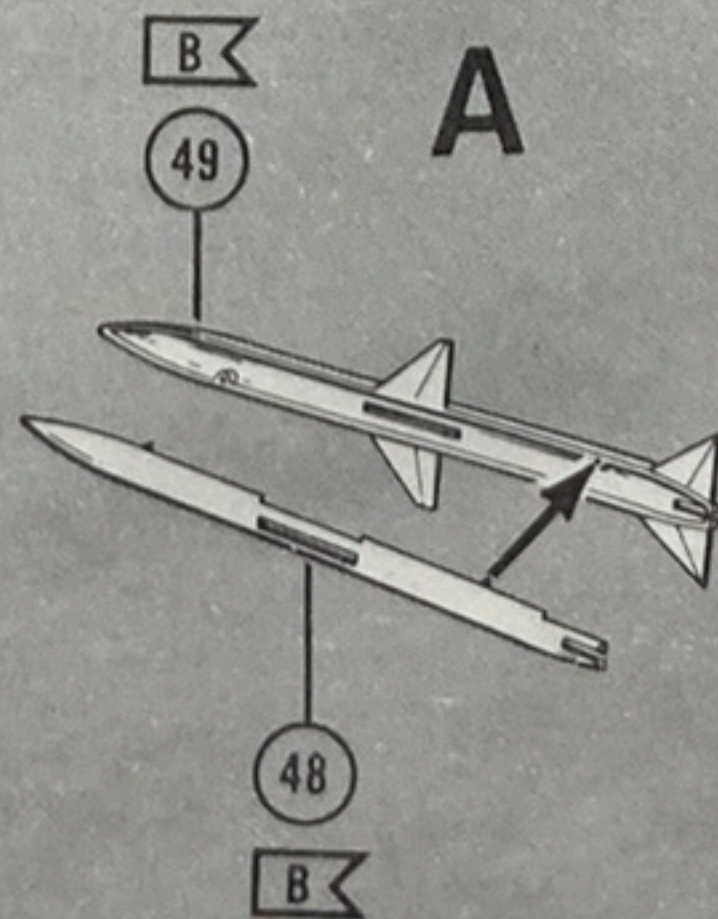

18

- 79 FUSELAGE FUEL TANK — RIGHT HALF
- 80 FUSELAGE FUEL TANK — LEFT HALF

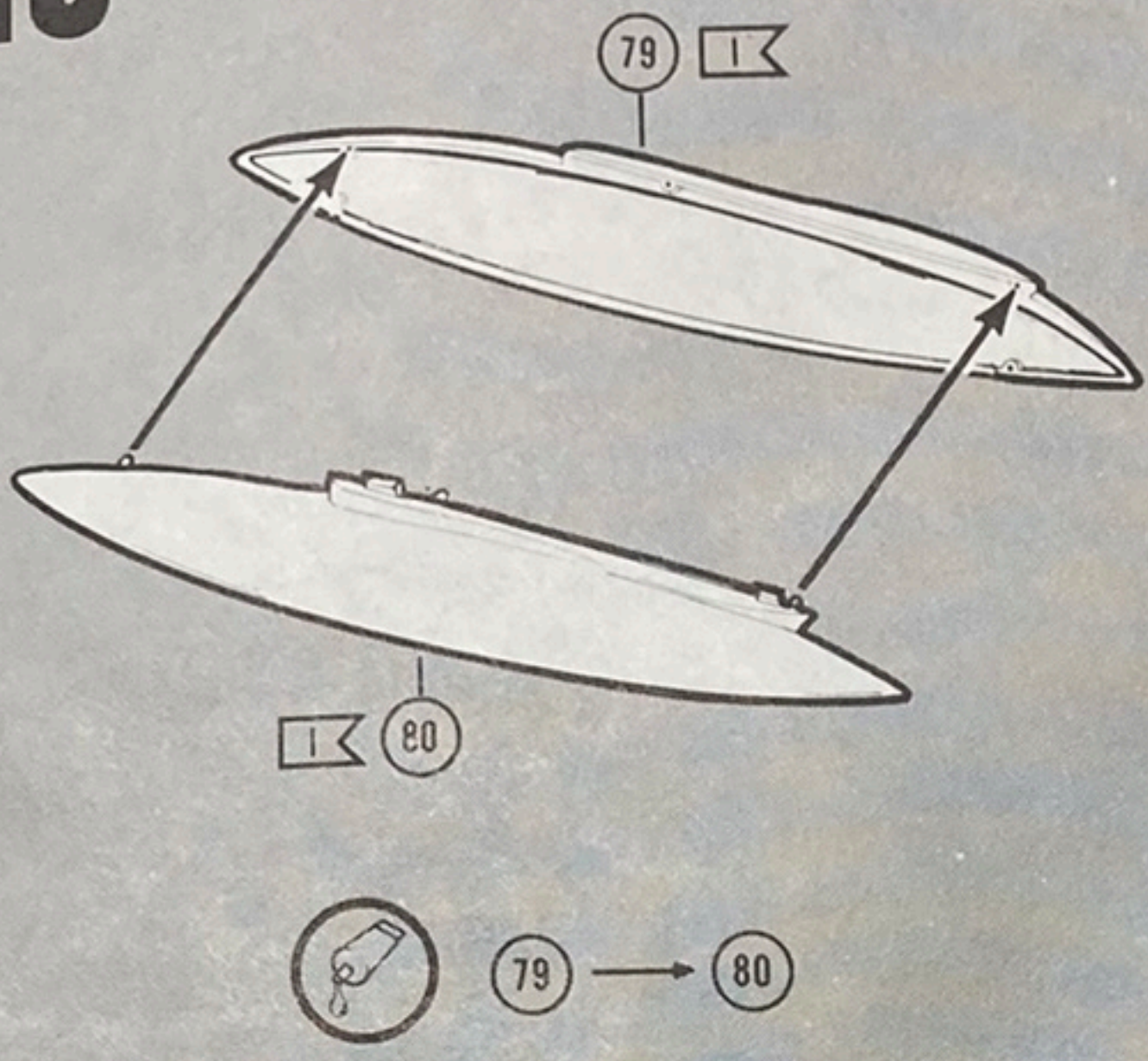

19

- 81 OUTERWING FUEL TANK — RIGHT HALF (2 PARTS)
- 82 OUTERWING FUEL TANK — LEFT HALF (2 PARTS)
- 83 LEFT TANK SWAY BRACE
- 84 RIGHT TANK SWAY BRACE

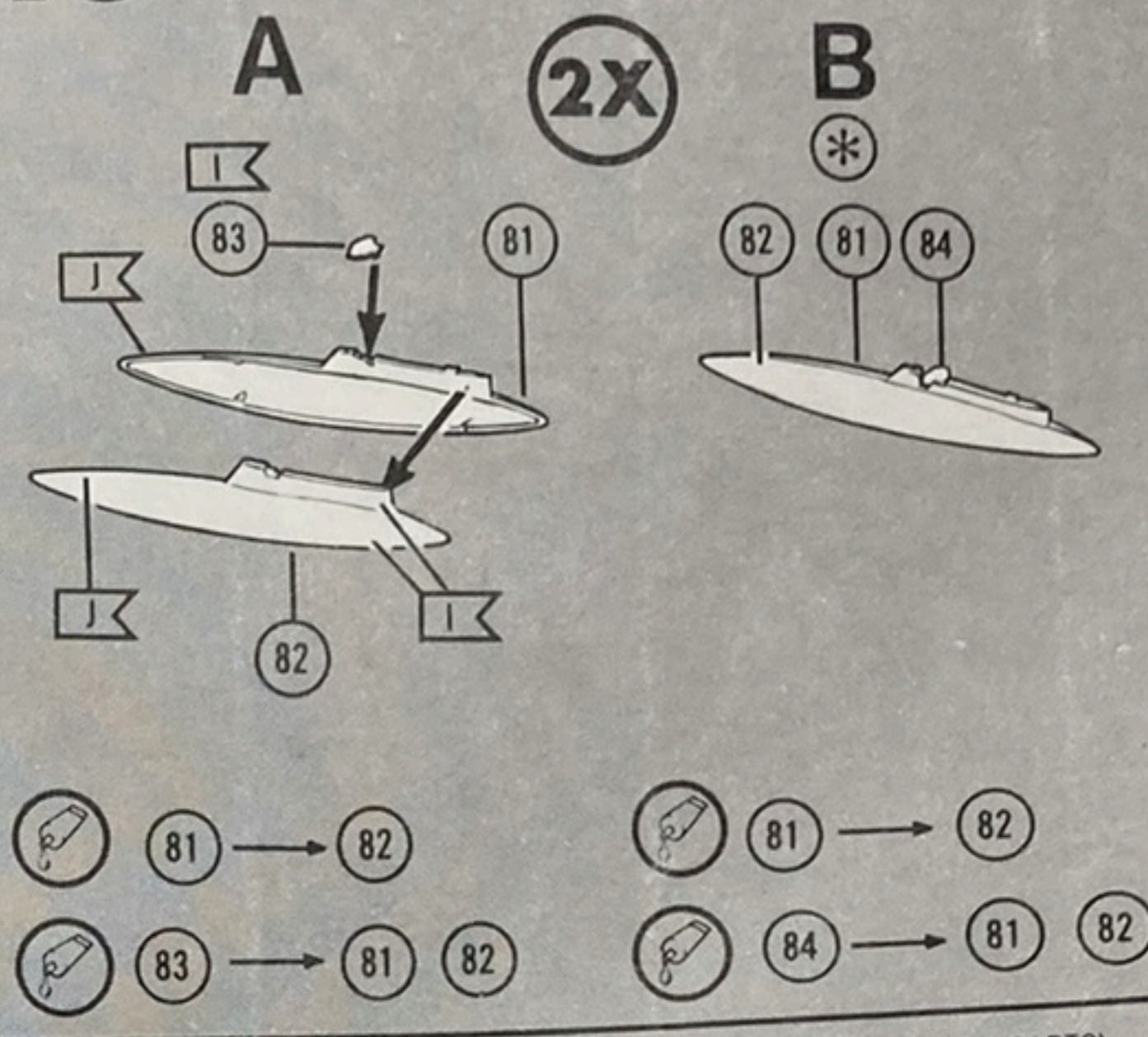

20

- 85 WEAPON PYLON — LEFT HALF (2 PARTS)
- 86 WEAPON PYLON — RIGHT HALF (2 PARTS)
- 87 LEFT PYLON FORWARD SWAY BRACE
- 88 LEFT PYLON REAR SWAY BRACE
- 89 RIGHT PYLON FORWARD SWAY BRACE
- 90 RIGHT PYLON REAR SWAY BRACE



21

- 91 SIDEWINDER FORWARD FIN (4 PARTS)
- 92 SIDEWINDER HALF WITH FIN (4 PARTS)
- 93 SIDEWINDER HALF WITHOUT FIN (4 PARTS)
- 94 SIDEWINDER REAR FIN (4 PARTS)

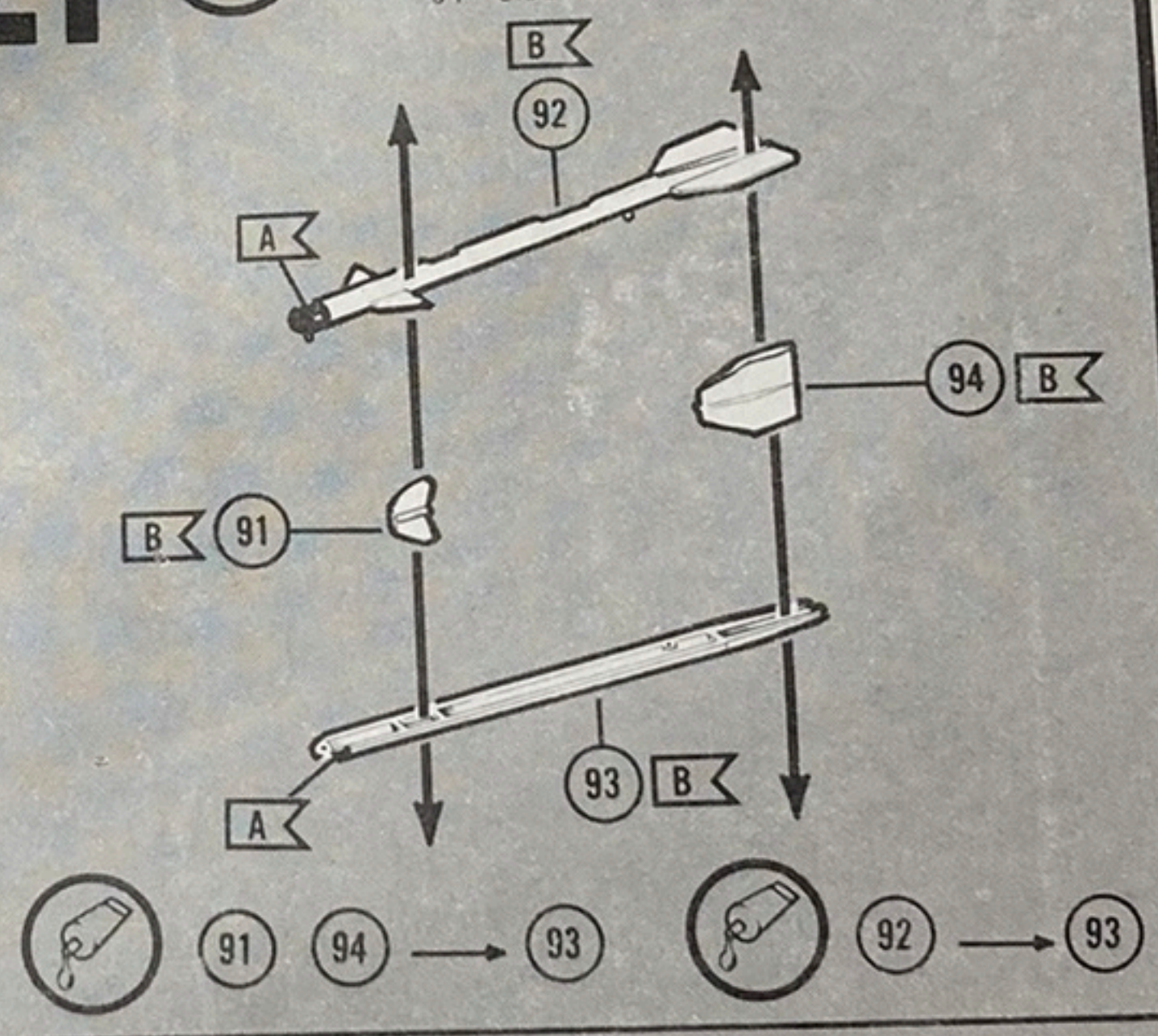

22

- 95 LAUNCHING RAIL — TOP HALF (4 PARTS)
- 96 LAUNCHING RAIL — BOTTOM HALF (4 PARTS)

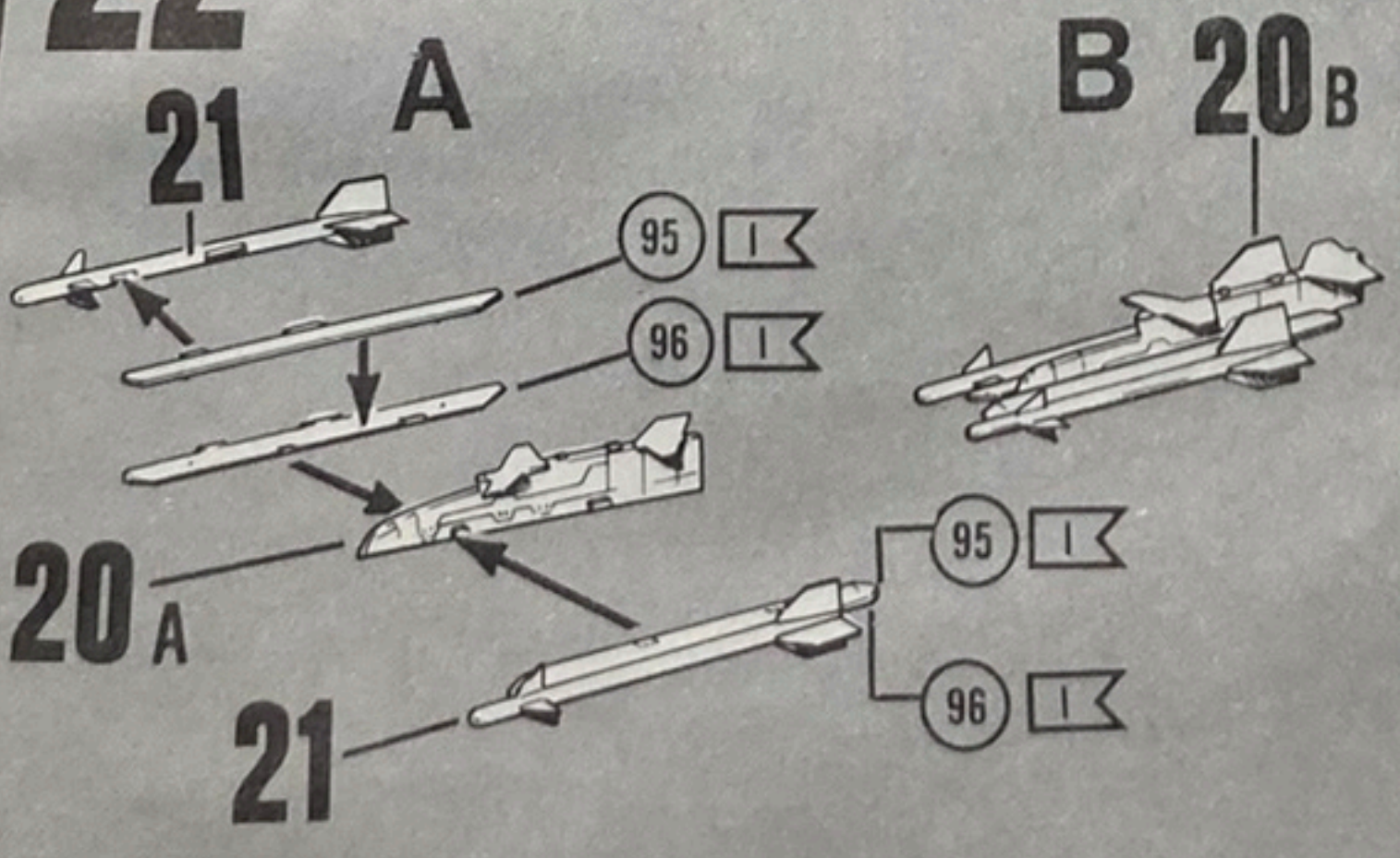

23

- 97 TRIPLE EJECTOR RACK — LEFT HALF (2 PARTS)
- 98 TRIPLE EJECTOR RACK — RIGHT HALF (2 PARTS)

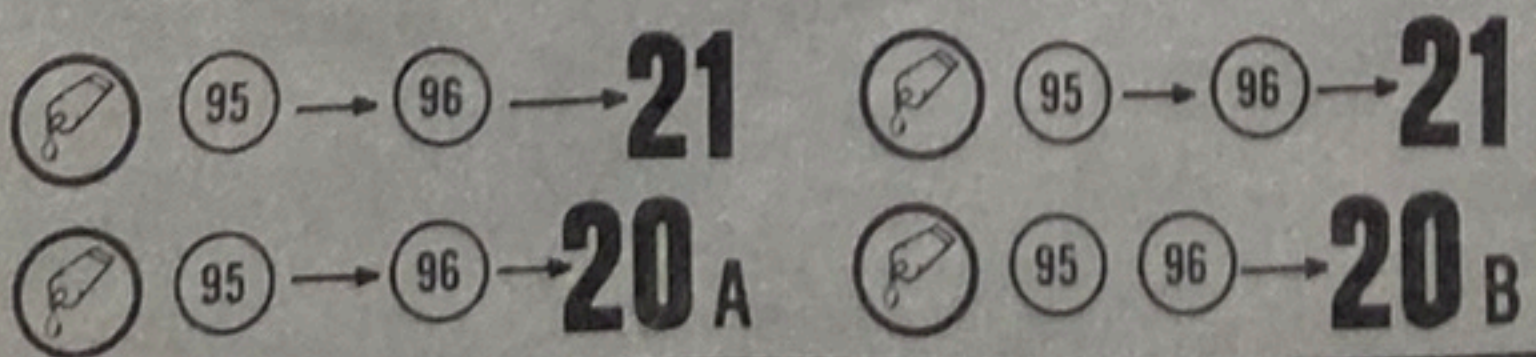
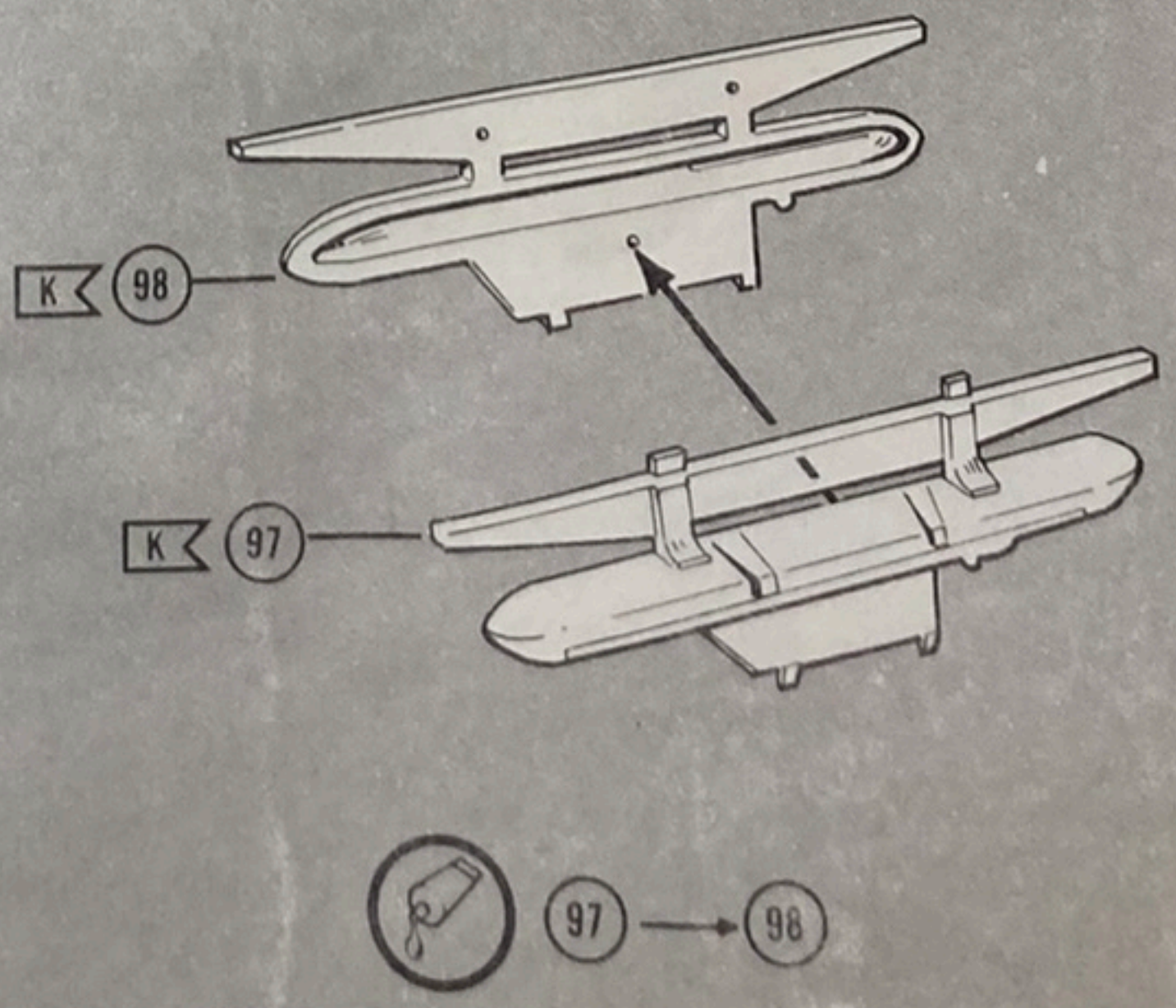

24

- 99 MARK 82 BOMB HALF WITH FINS (6 PARTS)
- 100 MARK 82 BOMB HALF WITHOUT FINS (6 PARTS)
- 101 MARK 82 BOMB TAIL FINS (6 PARTS)

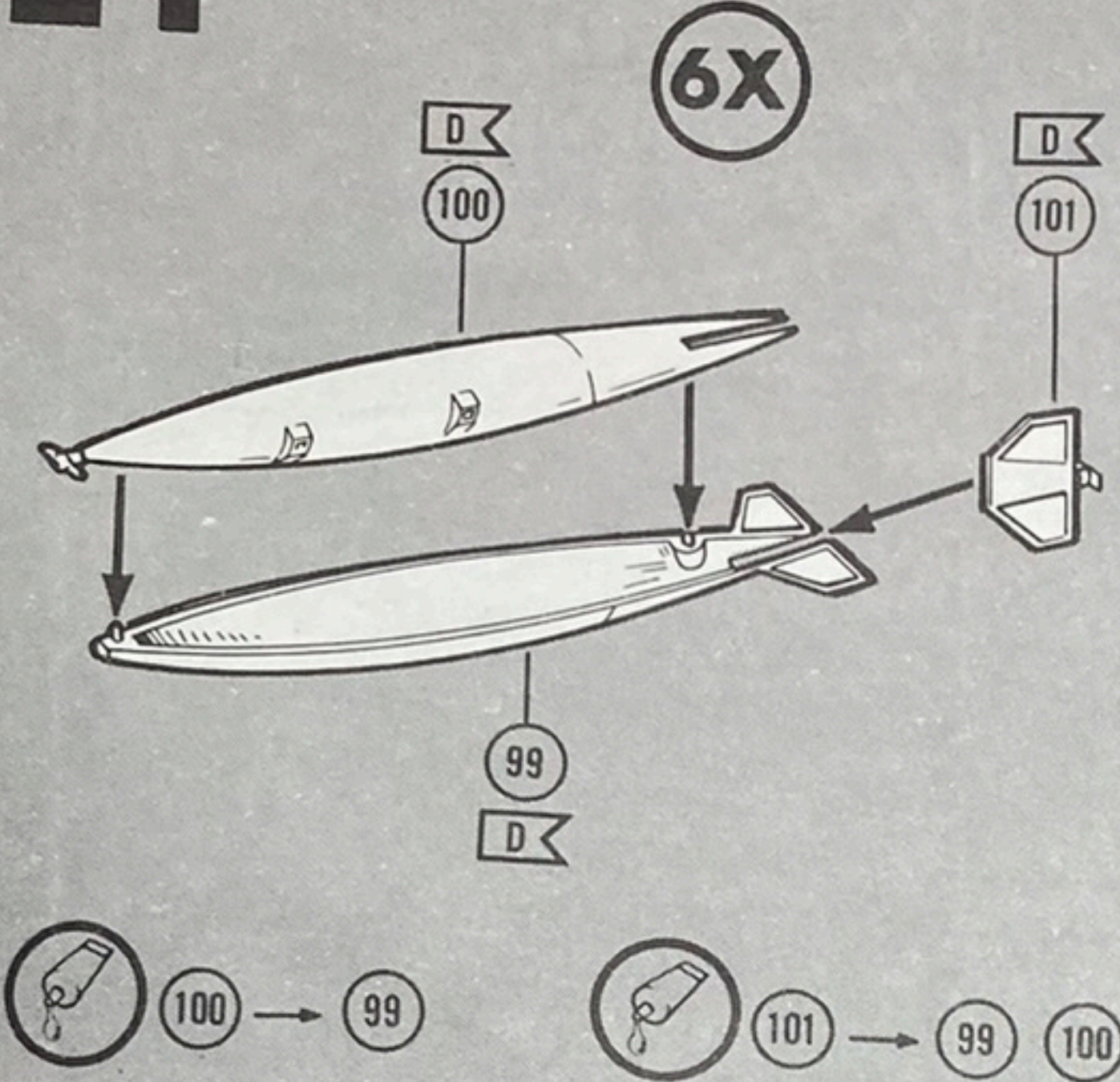

25

2X

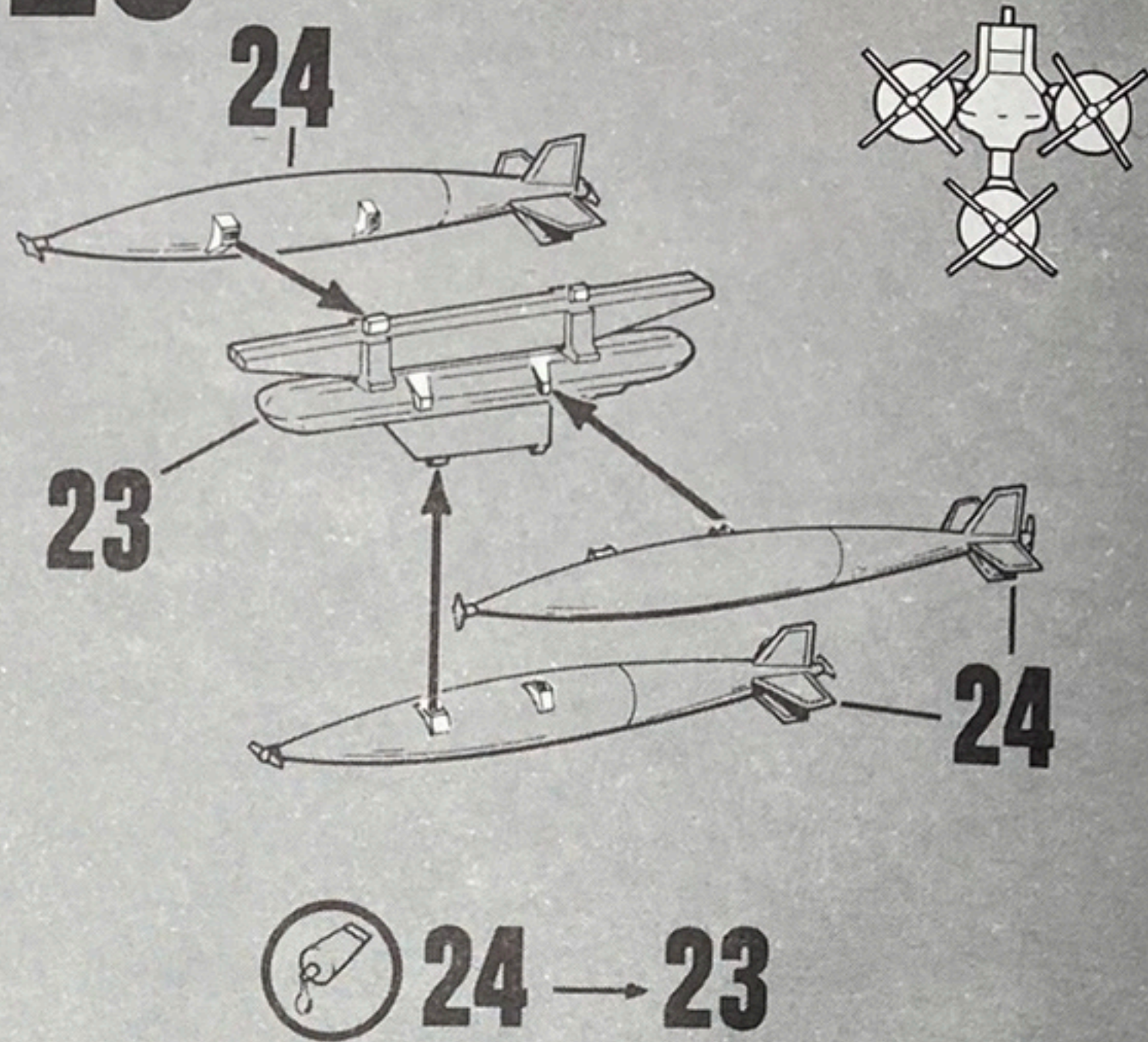

26

11 ENGINE EXHAUST CONE

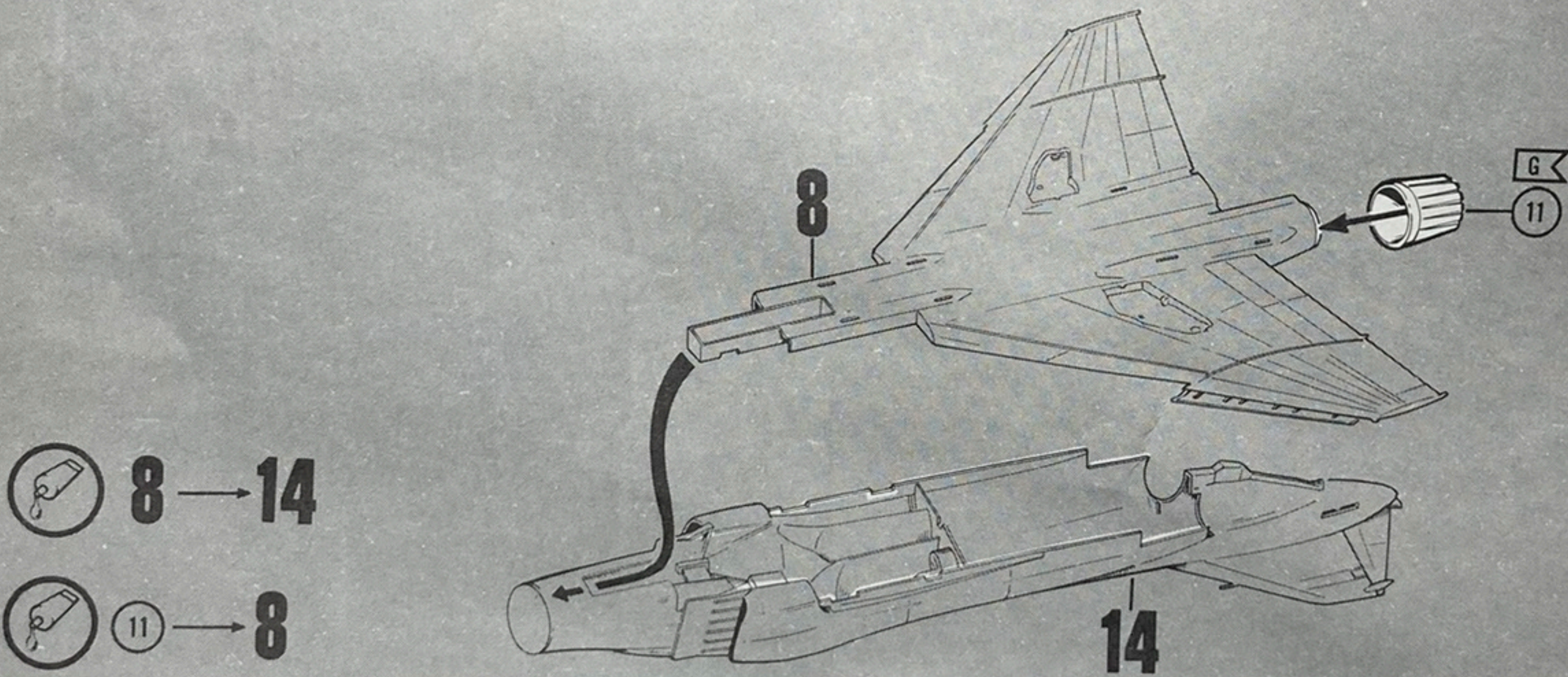

27

(B)

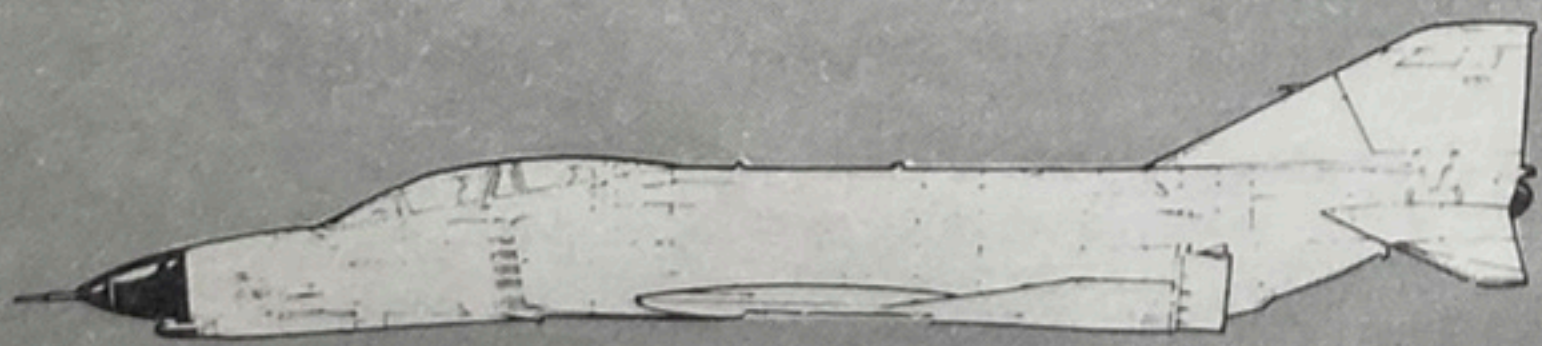

28

(B)

- 40 LEFT MAIN GEAR STRUT DOOR — CENTER
- 41 RIGHT MAIN GEAR STRUT DOOR — CENTER
- 47 NOSE GEAR DOOR — FRONT HALF
- 53 RIGHT MAIN GEAR DOOR — OUTBOARD
- 54 RIGHT MAIN GEAR DOOR — INBOARD
- 56 LEFT MAIN GEAR DOOR — OUTBOARD
- 57 LEFT MAIN GEAR DOOR — INBOARD
- 60 NOSE GEAR DOOR — REAR HALF

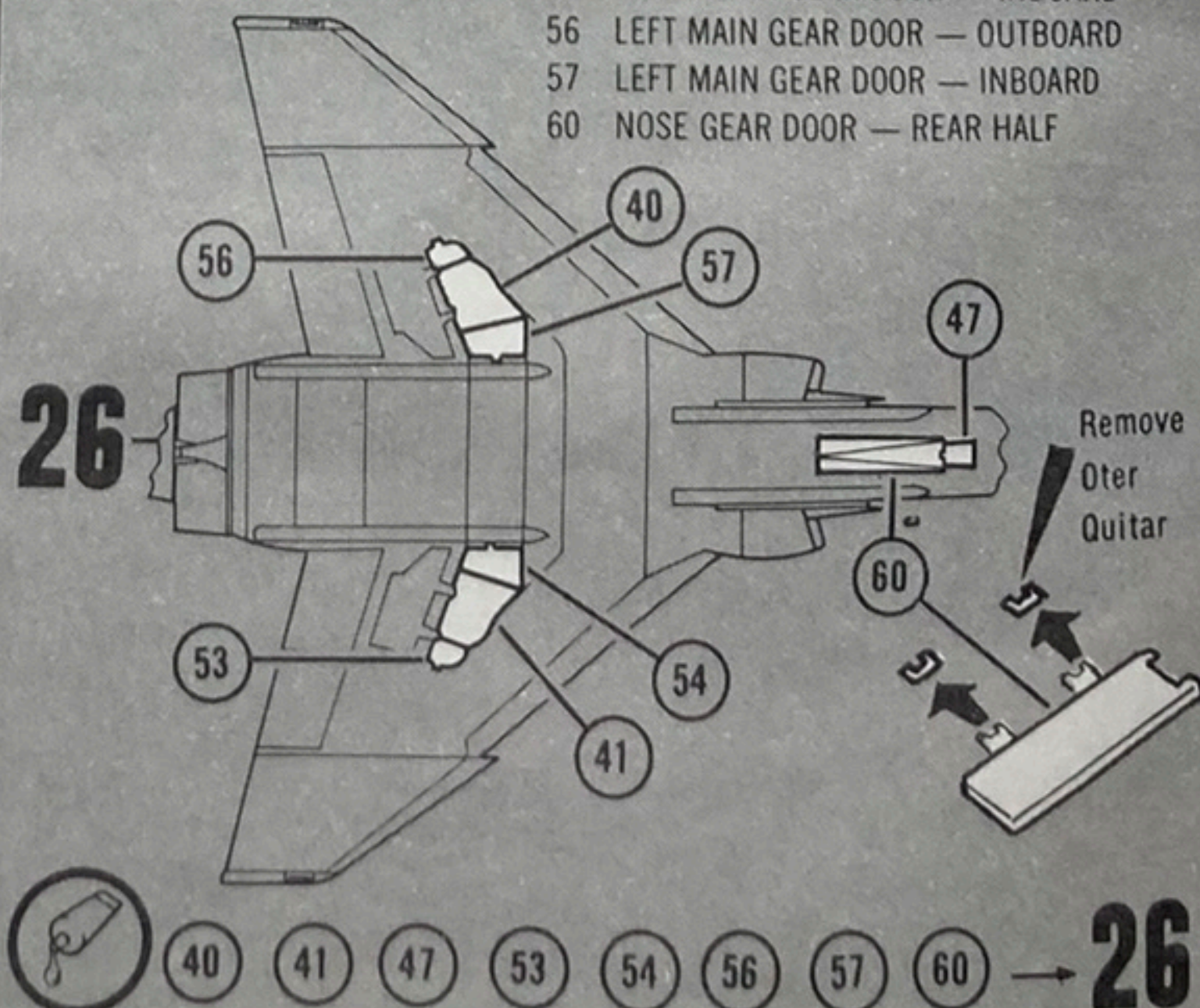

29 (A)

- 58 NOSE GEAR RETRACT LOCK
- 59 NOSE GEAR RETRACT STRUT
- 60 NOSE GEAR DOOR — REAR HALF

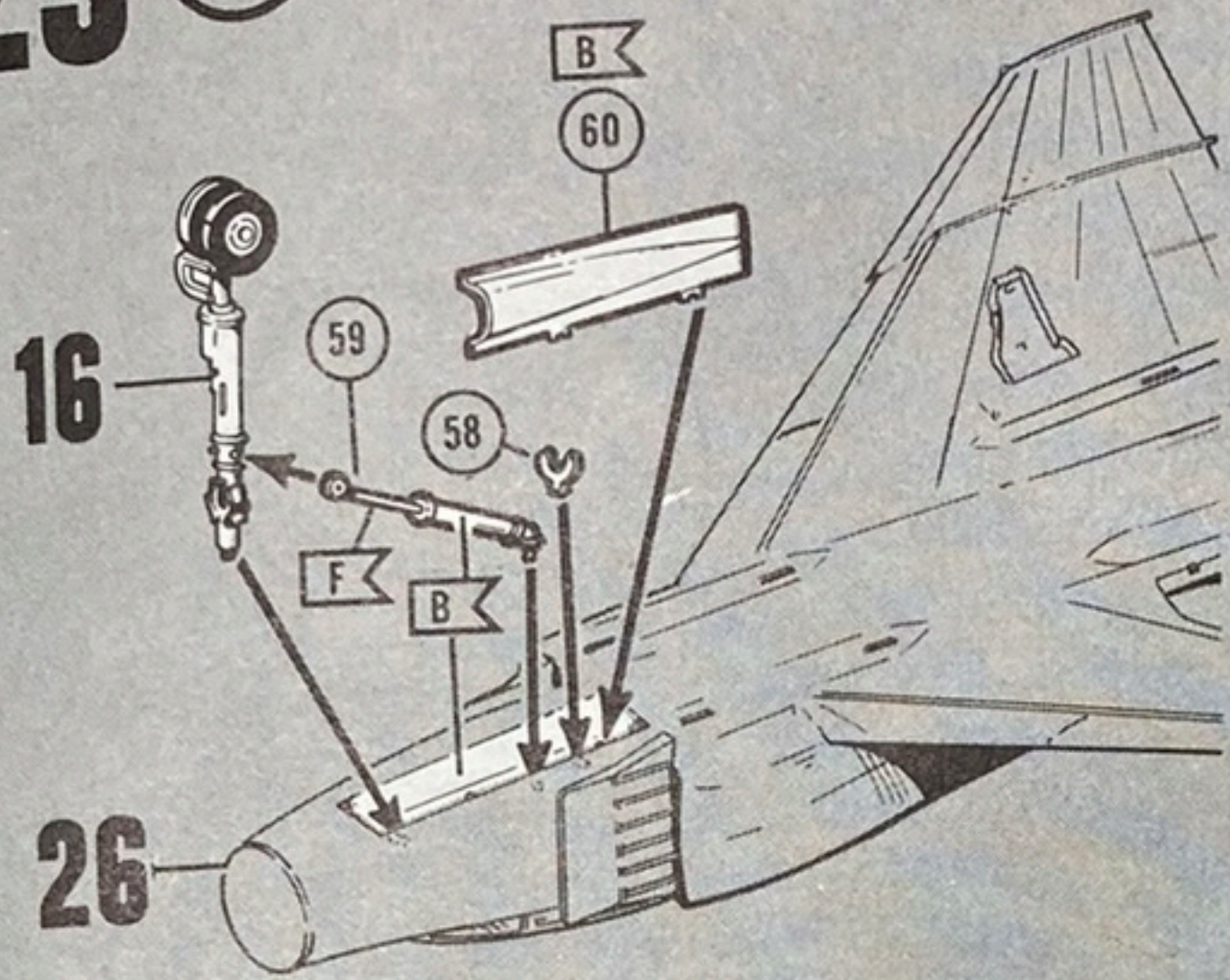

16 → 26 58 → 16 26 59 60 → 26

30

- 55 LEFT MAIN GEAR RETRACT STRUT
- 56 LEFT MAIN GEAR DOOR — OUTBOARD
- 57 LEFT MAIN GEAR DOOR — INBOARD

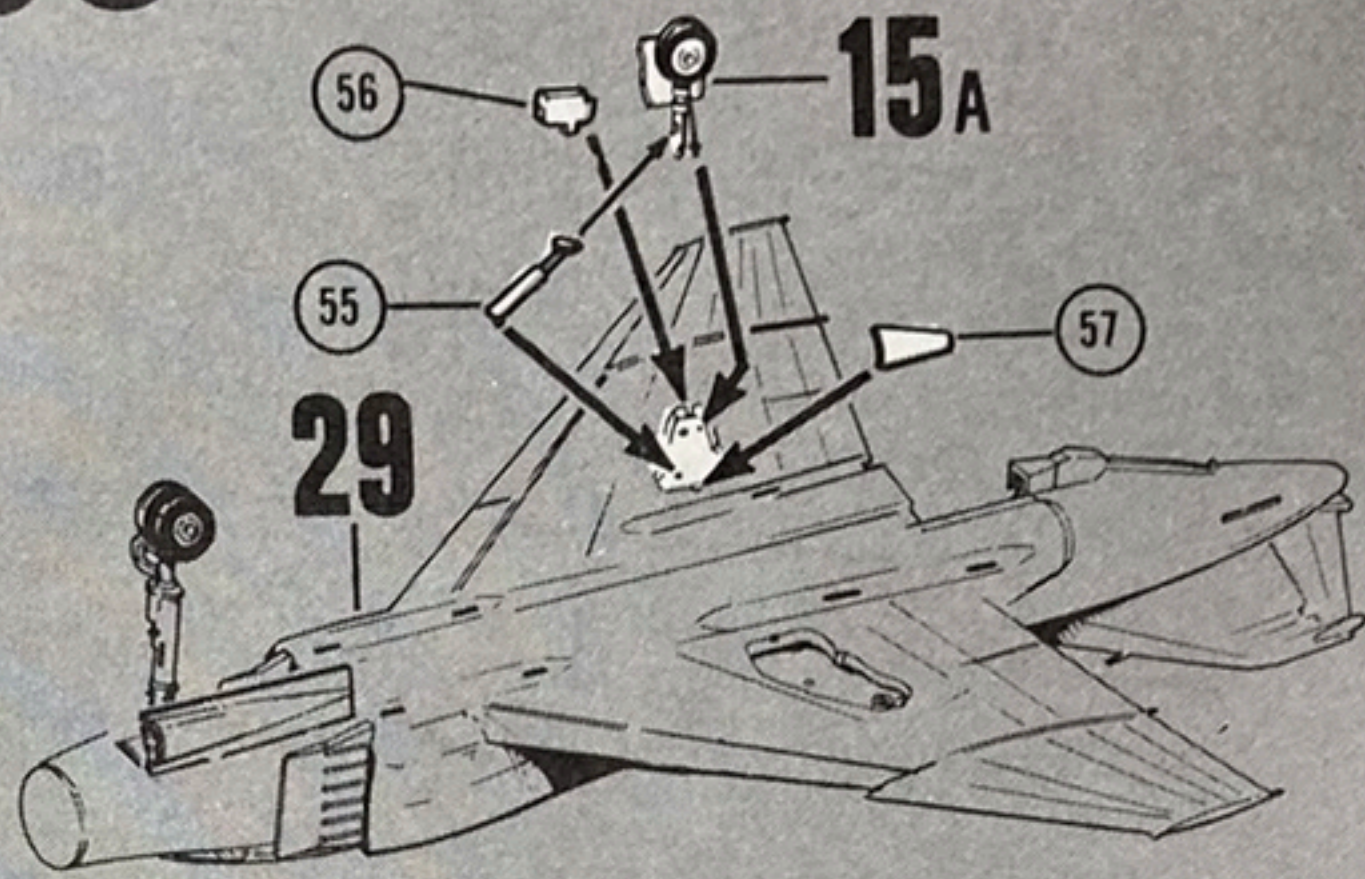

15A → 29 55 → 15A 29 56 57 → 29

31

- 52 RIGHT MAIN GEAR RETRACT STRUT
- 53 RIGHT MAIN GEAR DOOR — OUTBOARD
- 54 RIGHT MAIN GEAR DOOR — INBOARD

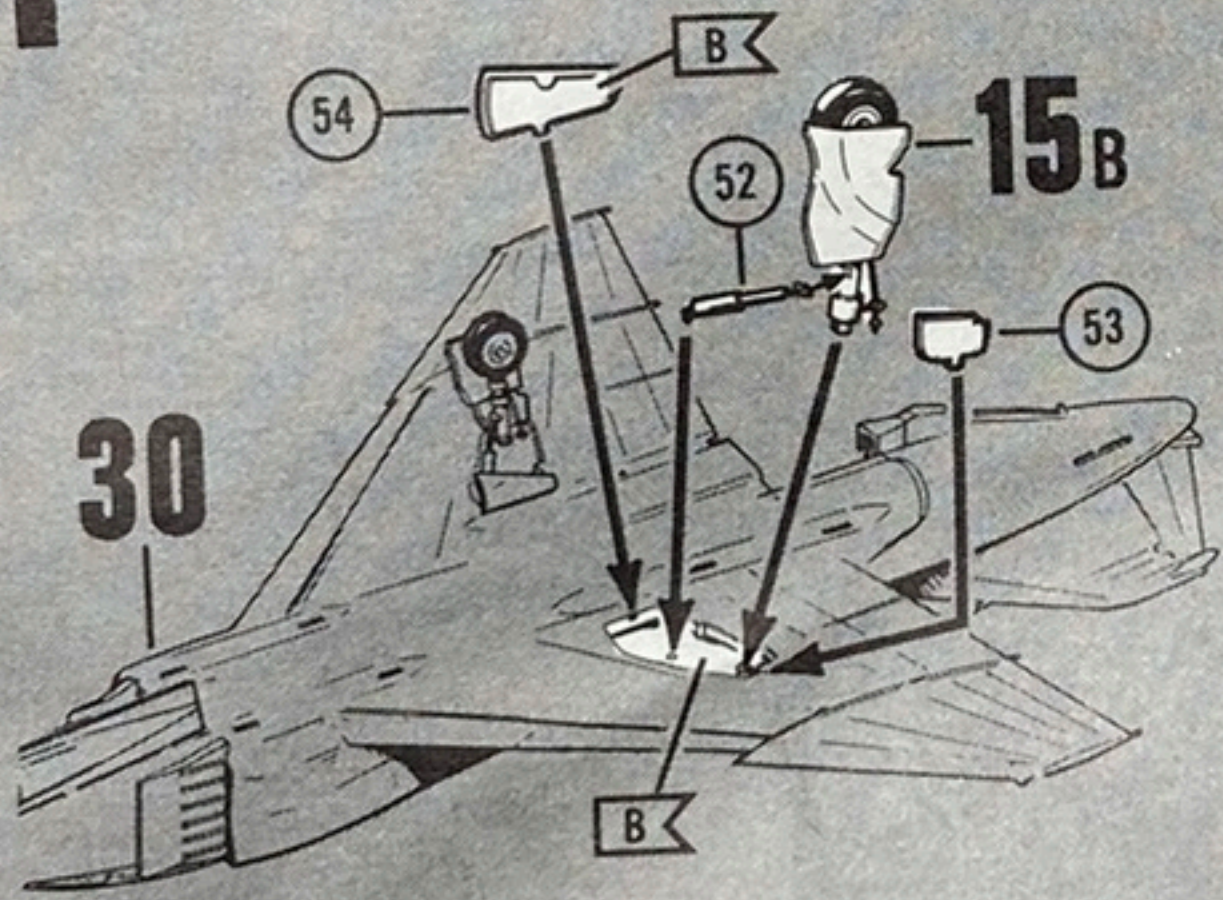

15B → 30 52 → 15B 30 53 54 → 30

32

- 61R RIGHT AIR DUCT FAIRING
- 61L LEFT AIR DUCT FAIRING

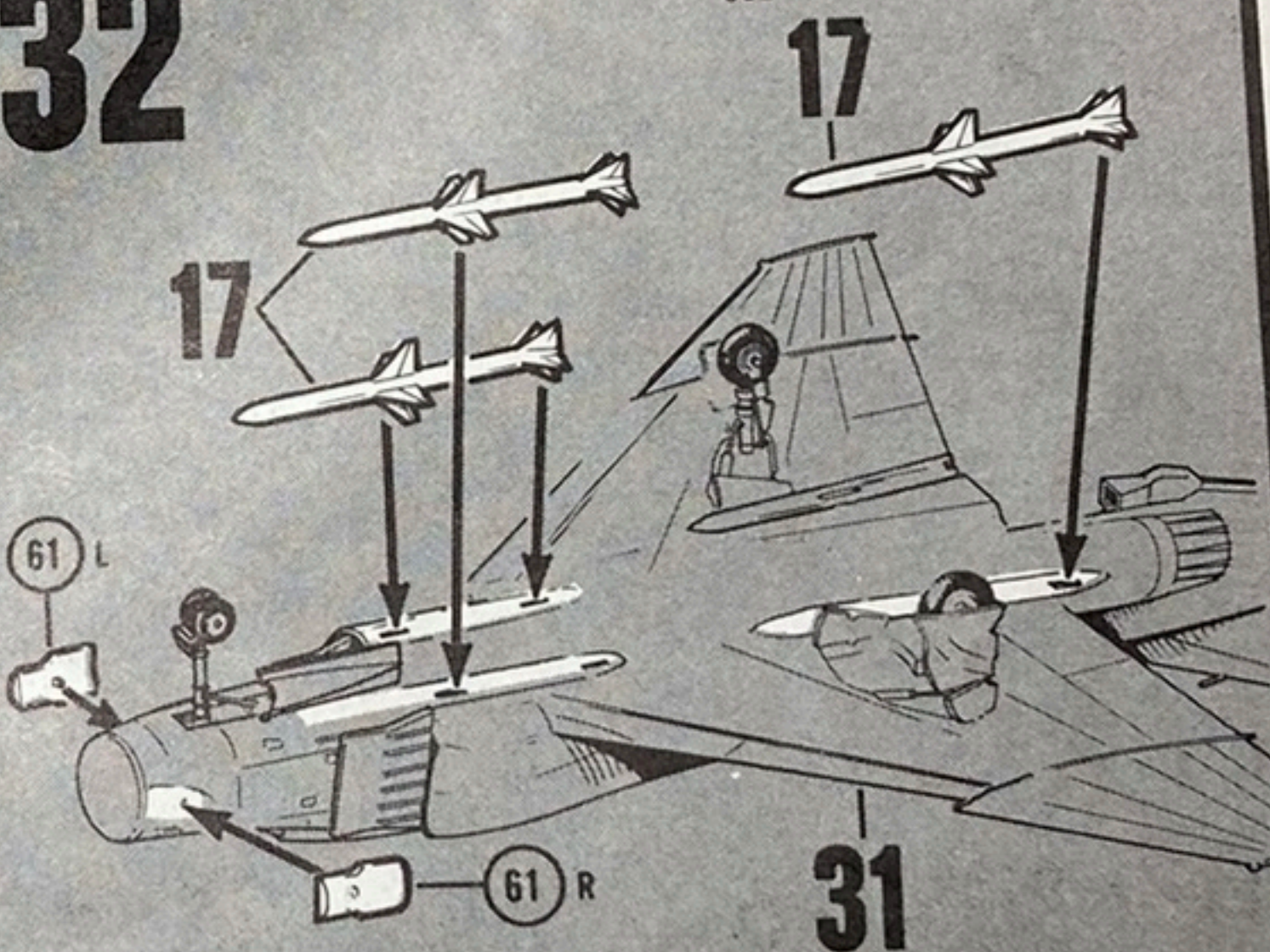

61 L 61 R → 31 3X 17 31

33

- 62 LEFT STABILIZER — BOTTOM
- 63 LEFT STABILIZER — TOP
- 64 RIGHT STABILIZER — BOTTOM
- 65 RIGHT STABILIZER — TOP

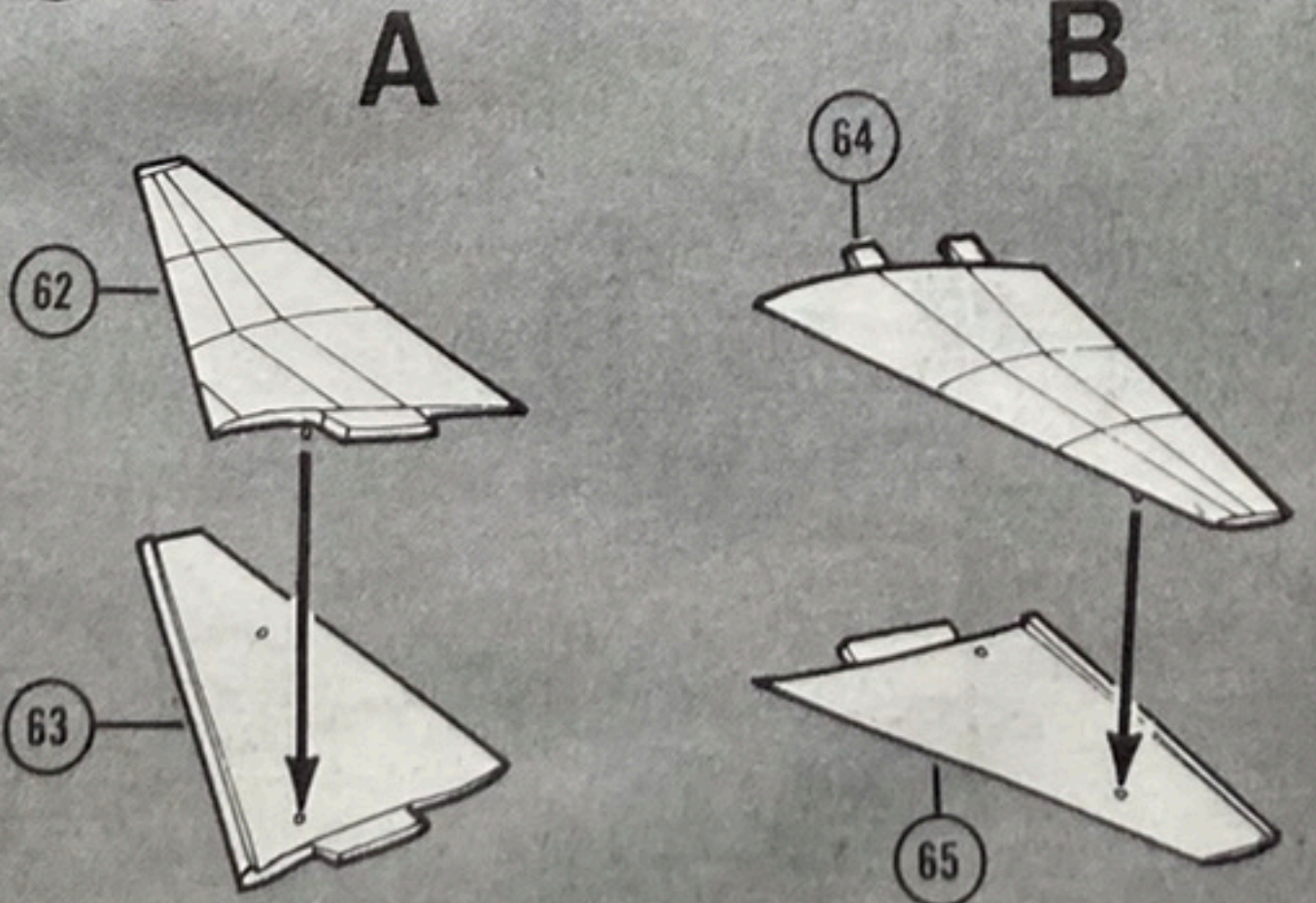

62 → 63 64 → 65

34

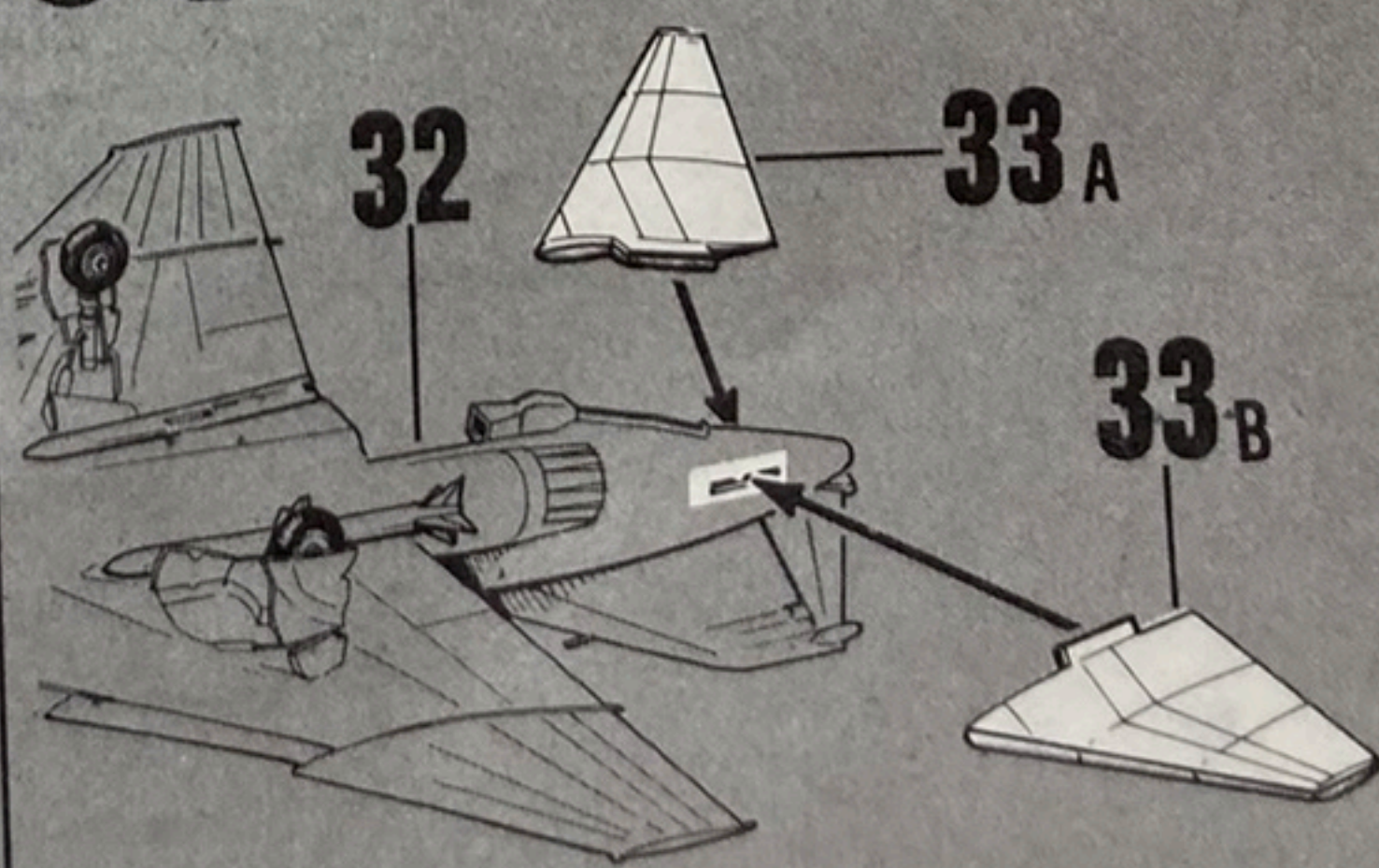

33 A-B → 32

35

- 66 RADAR ANTENNA
- 67 RADAR DISH
- 68 RADAR UNIT
- 72 NOSE EXTENSION

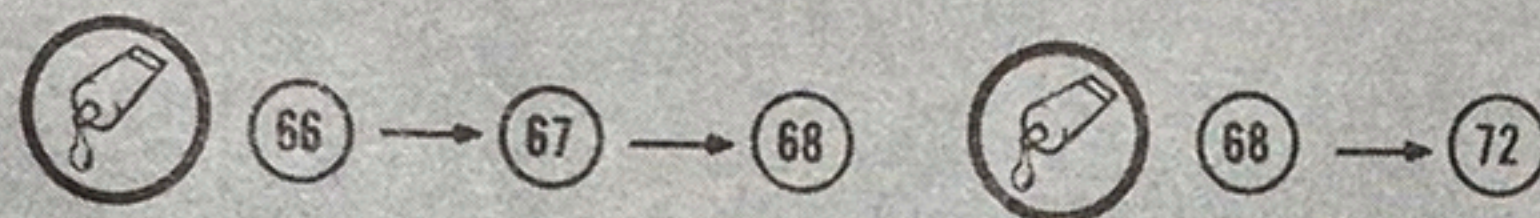
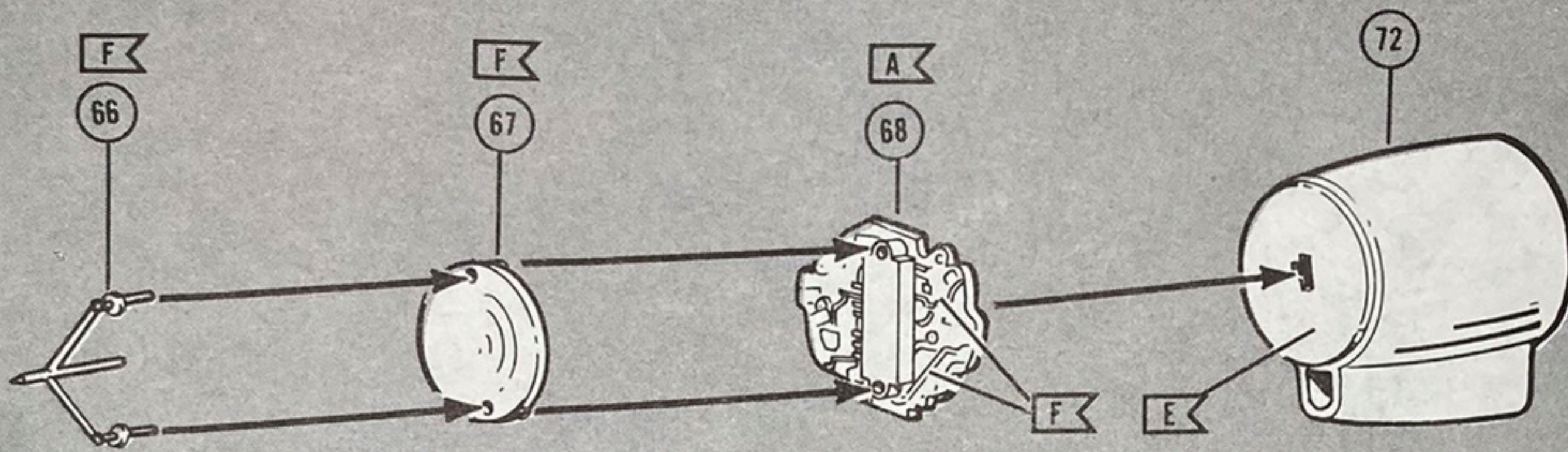

36

- 47 NOSE GEAR DOOR — FRONT HALF
- 73 GUN POD FAIRING

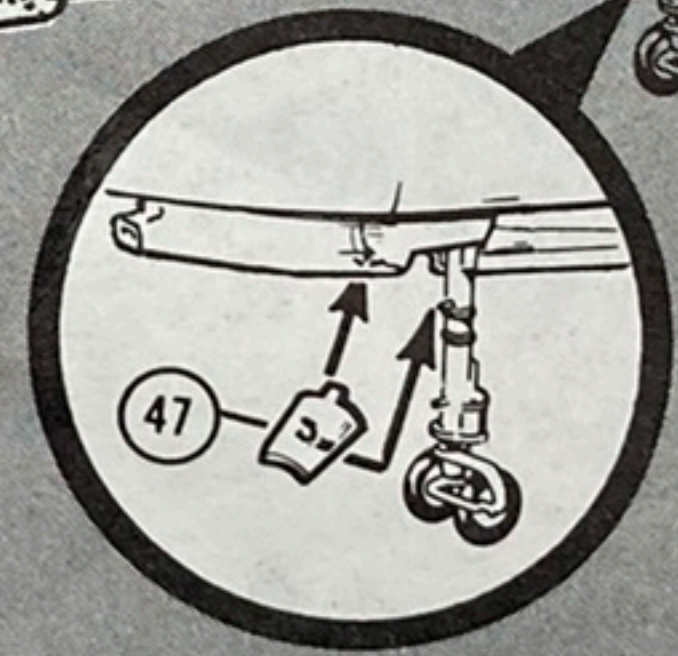
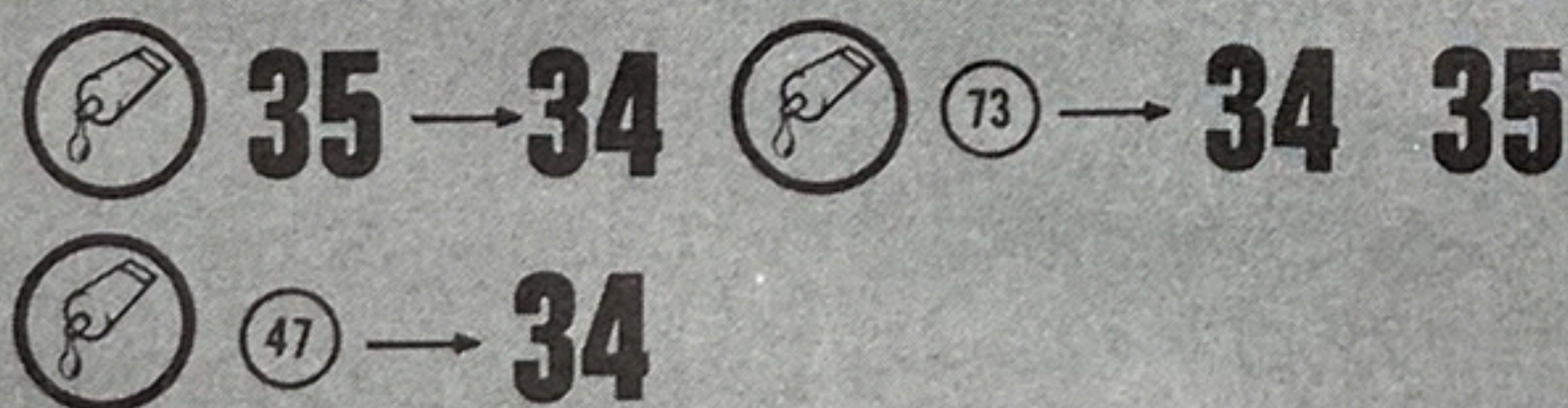
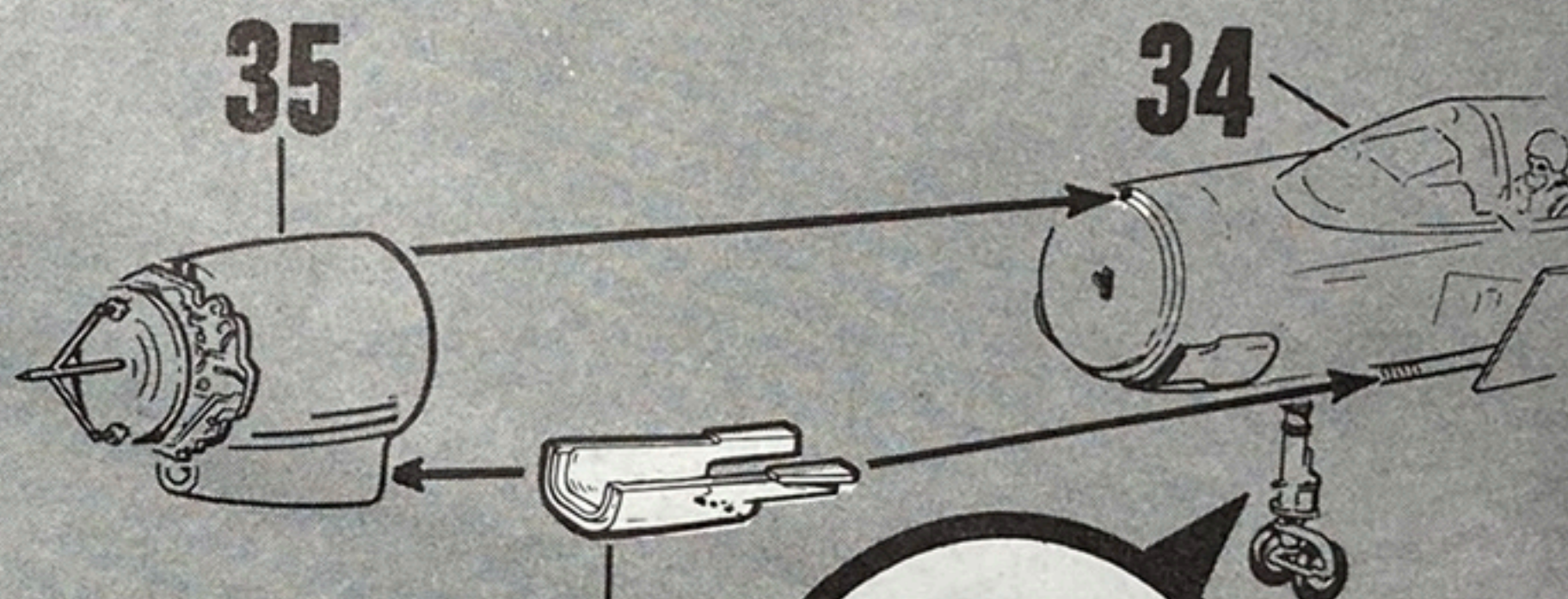

37

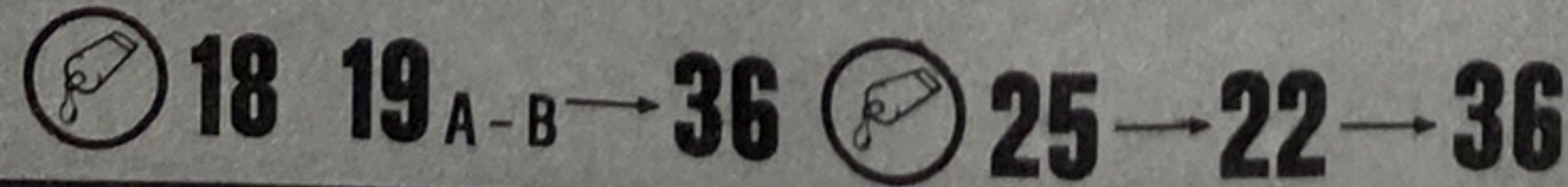
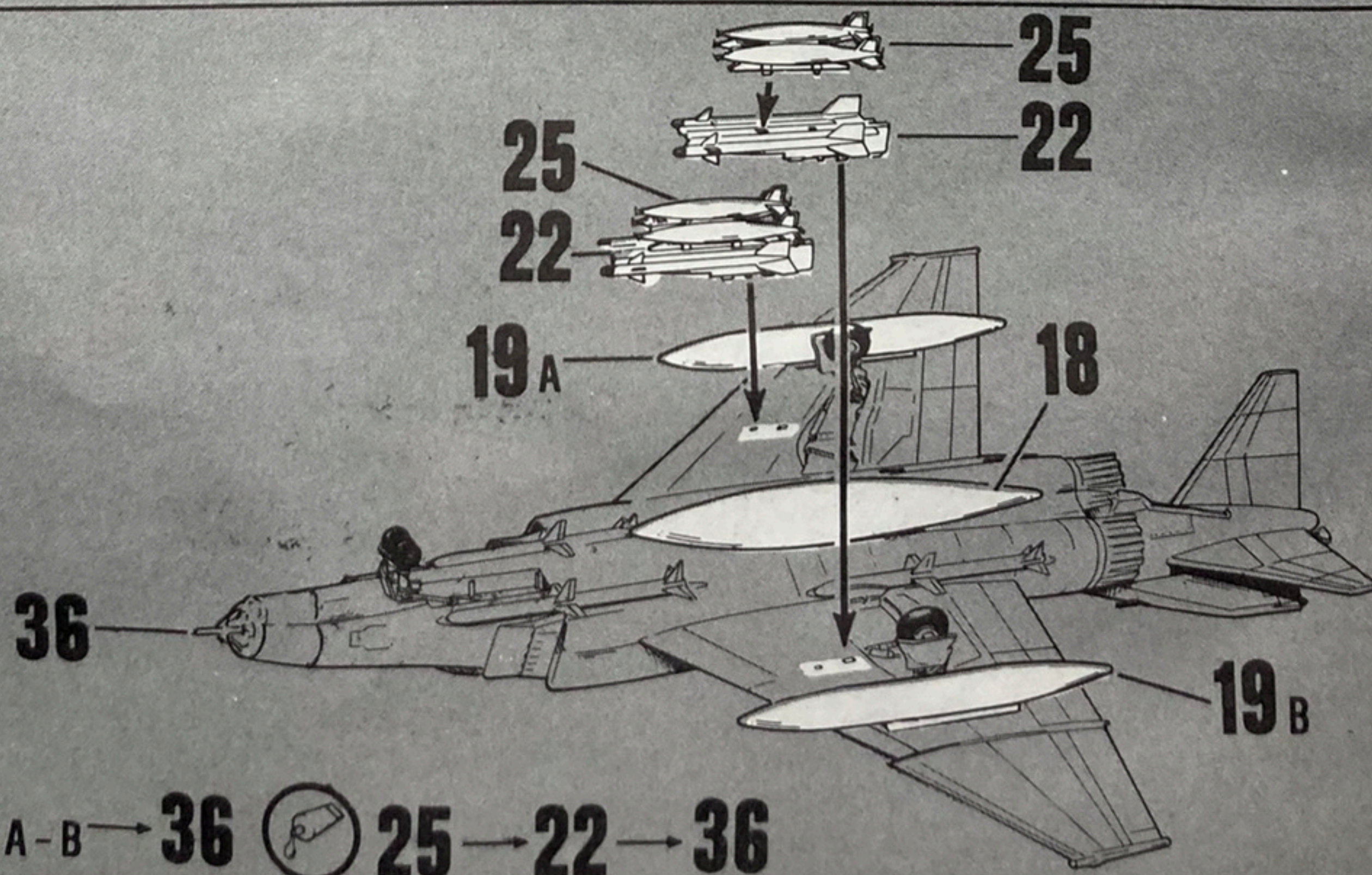

69 RADOME
70 PITOT TUBE

38

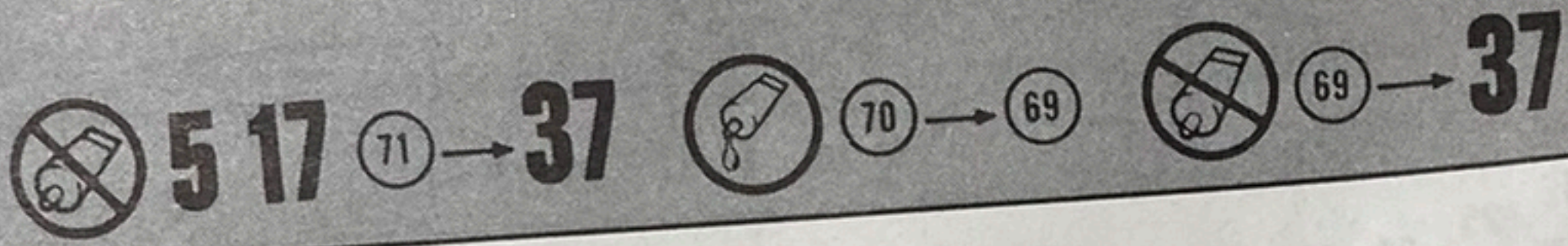
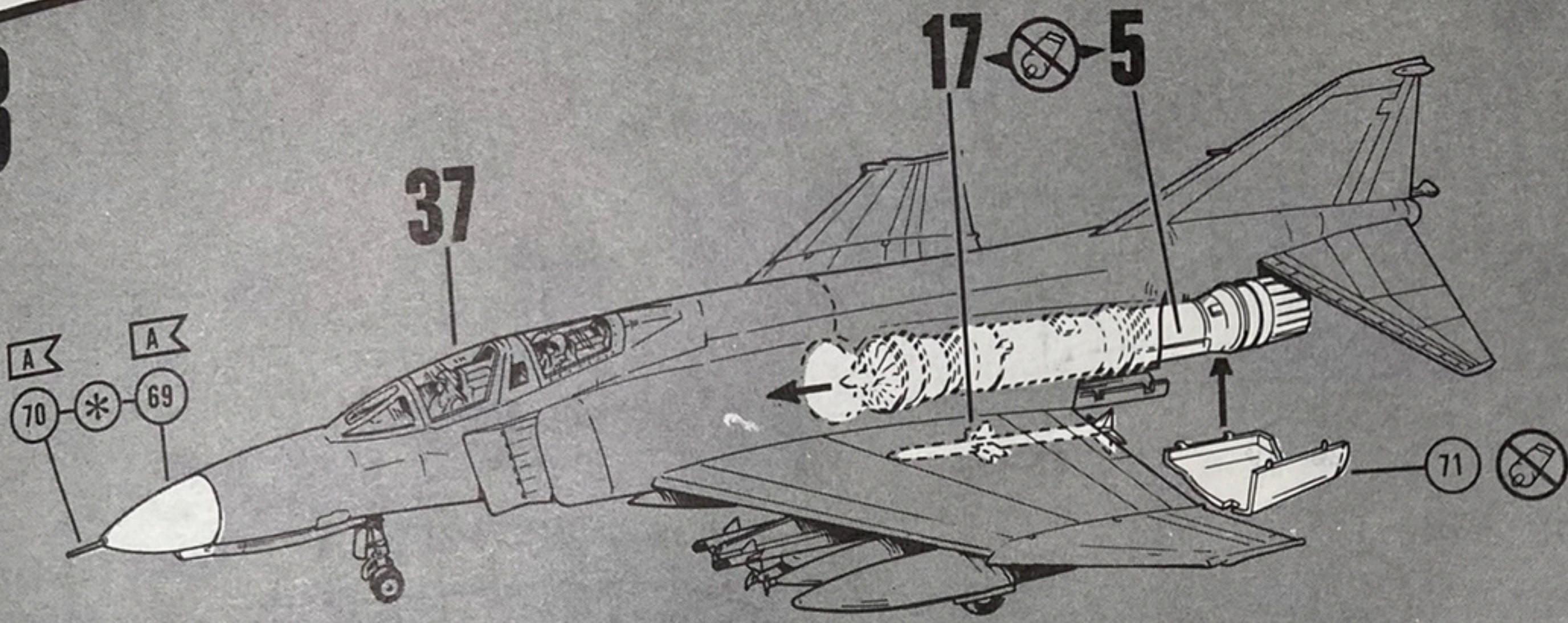

39

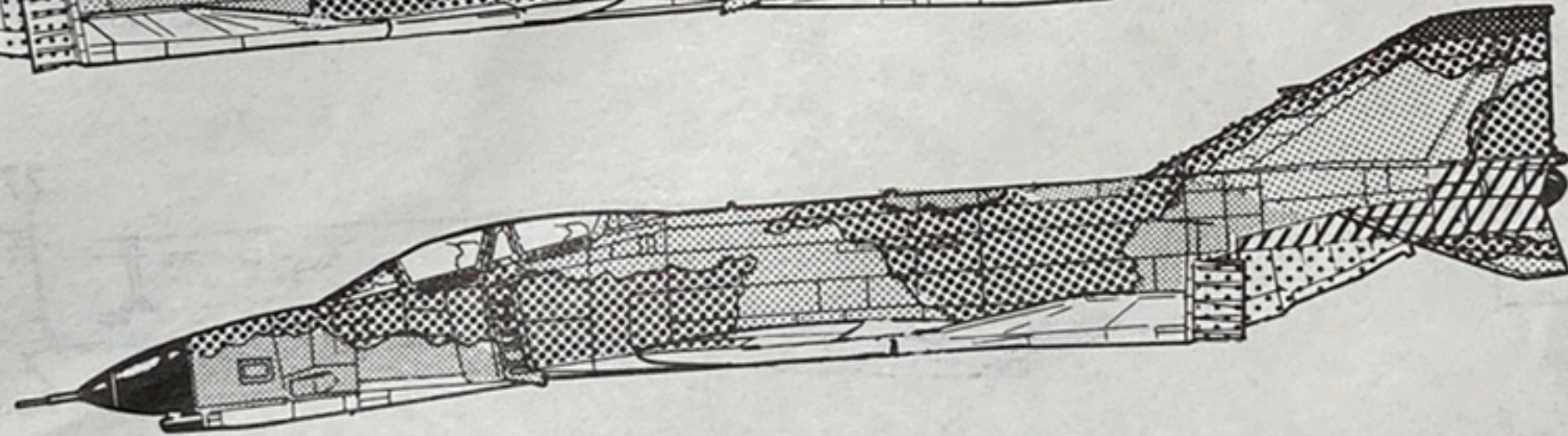
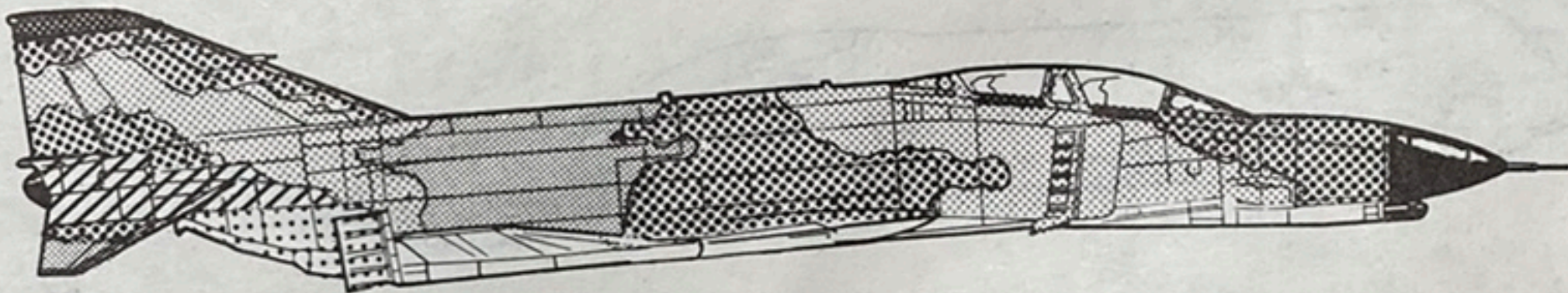

- A
- D
- F
- G
- I
- J
- K
- L

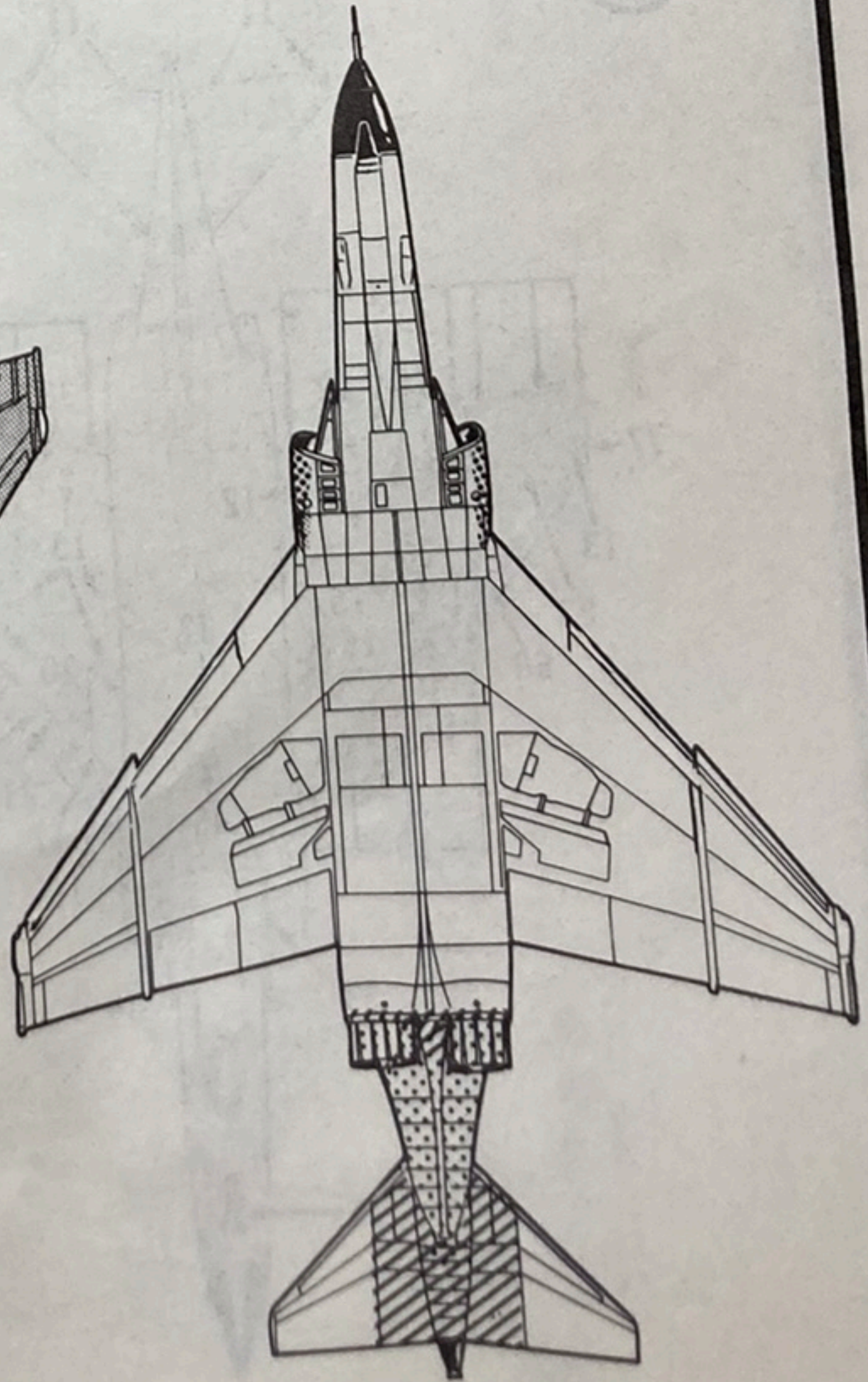
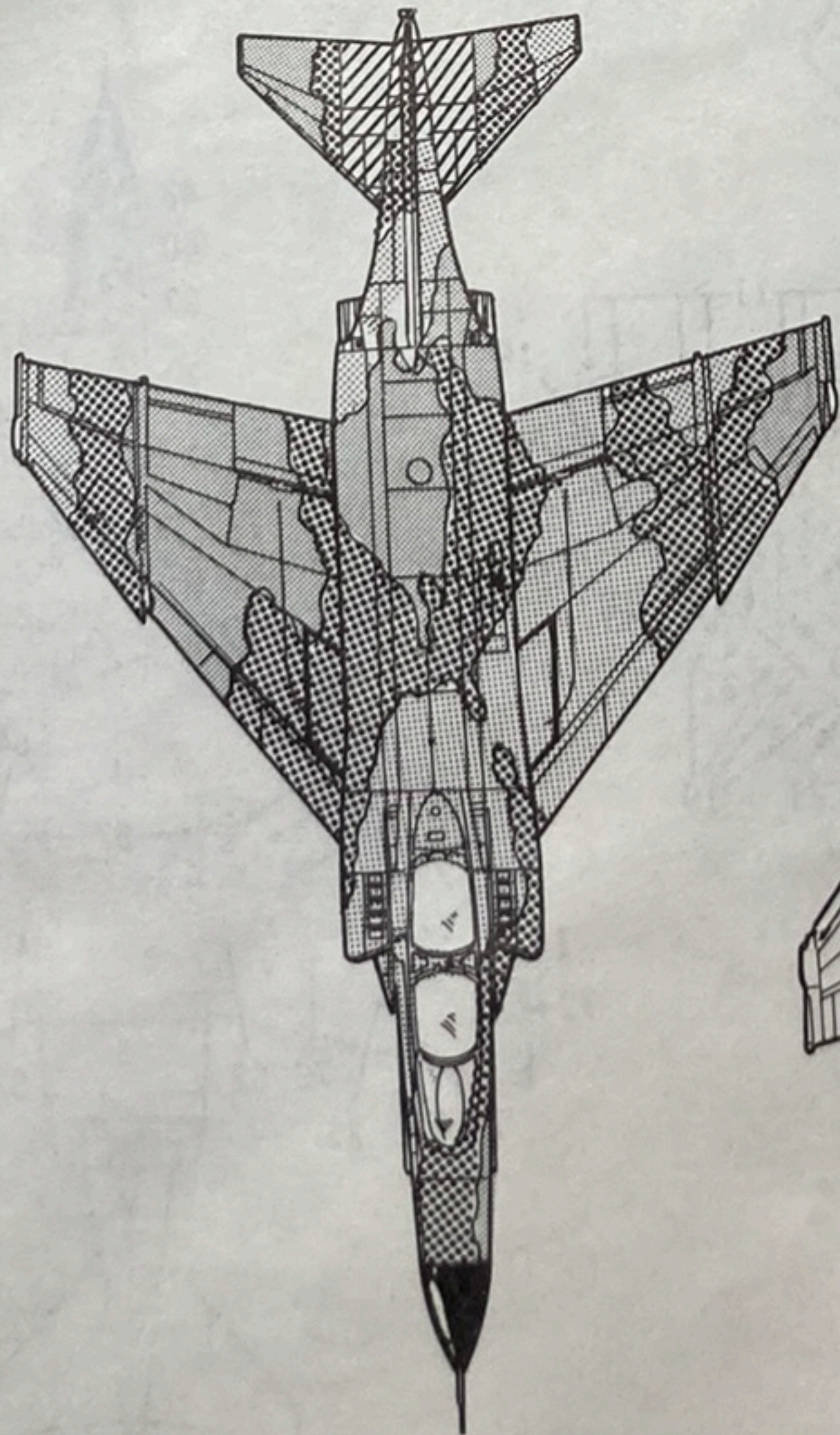

40

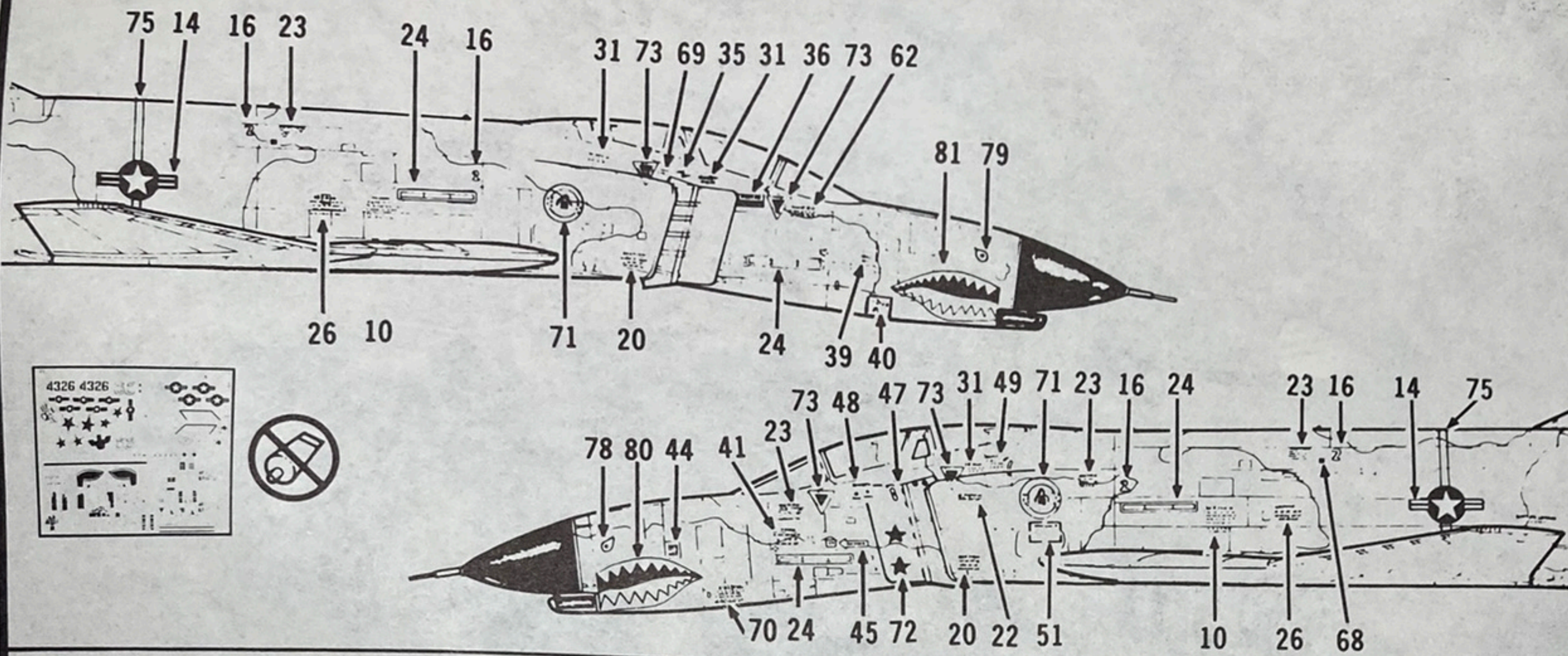

41

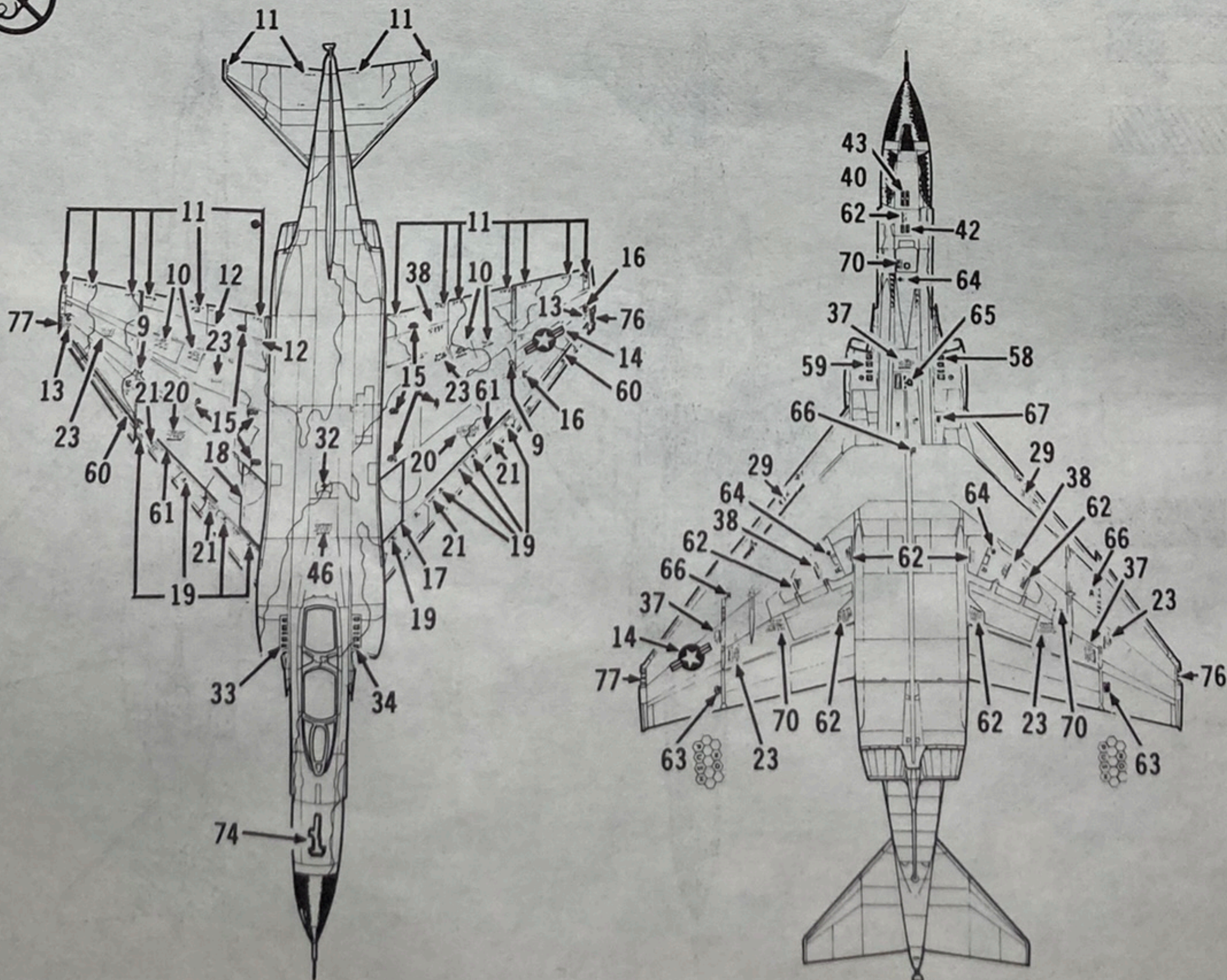
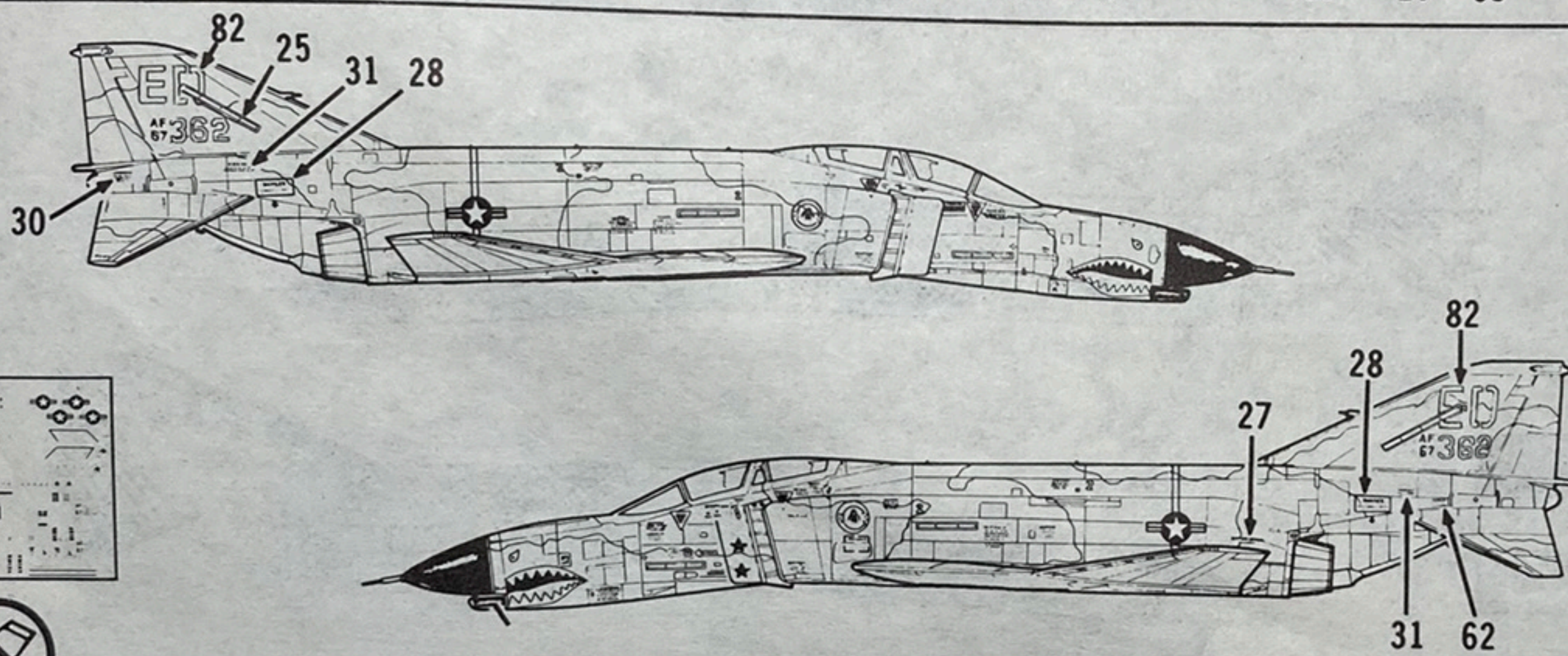

L	MATT DARK GREEN	VERT FONCE MAT	VERDE OSCURO MATE
M	MATT DARK GRAY	GRIS FONCE MAT	GRIS OSCURO MATE
N	MATT TAN	BRUN MAT	TOSTADO MATE
O	BRONZE	BRONZE	BRONZE

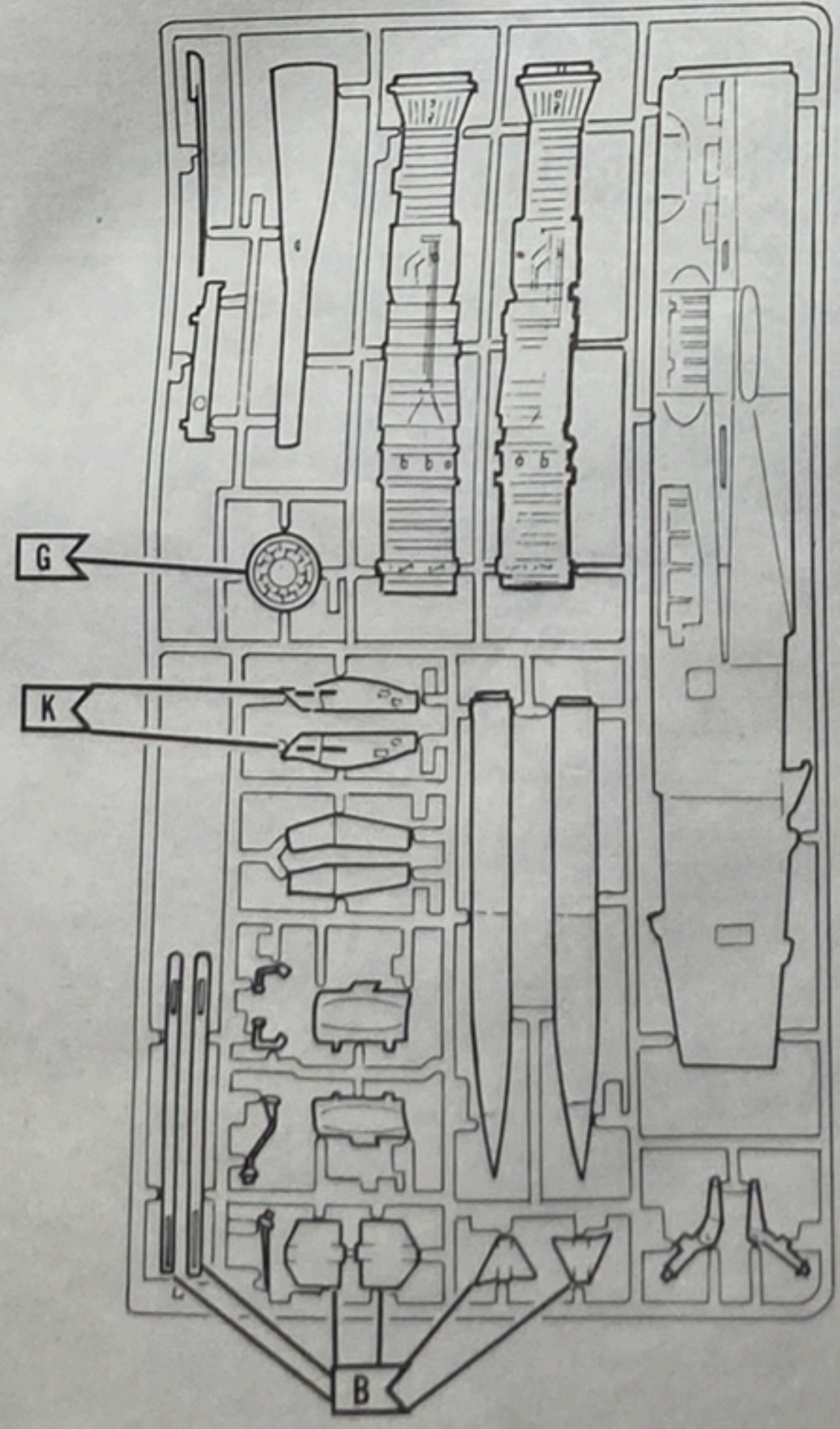
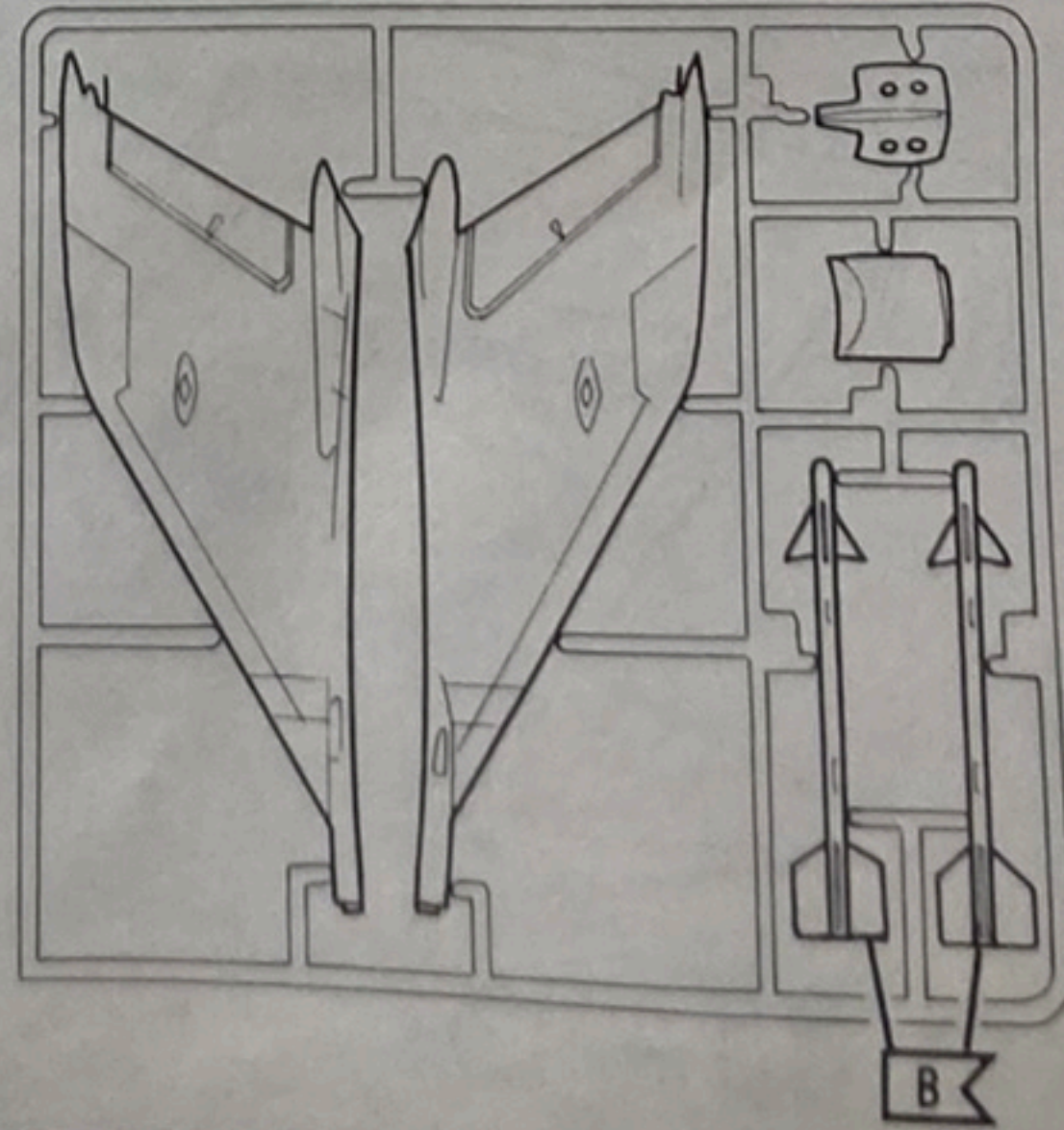
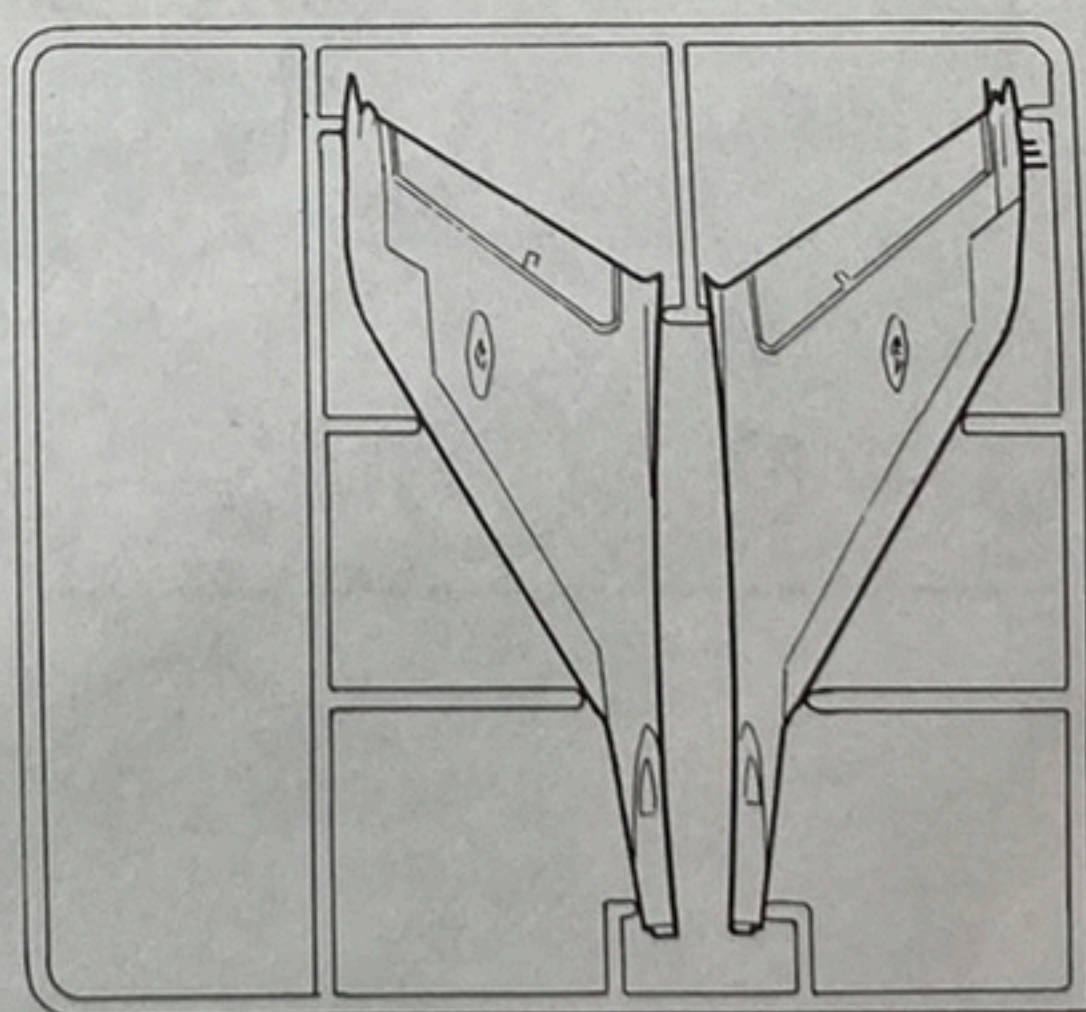
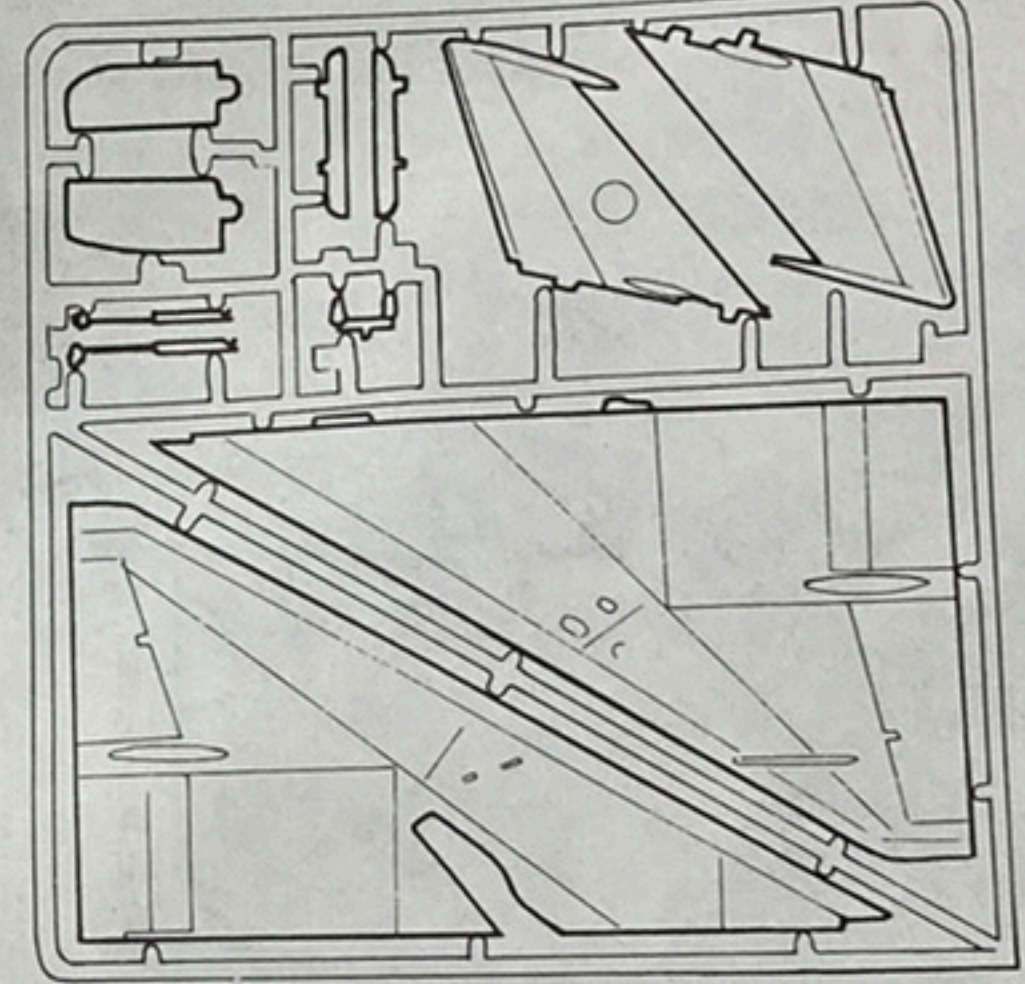
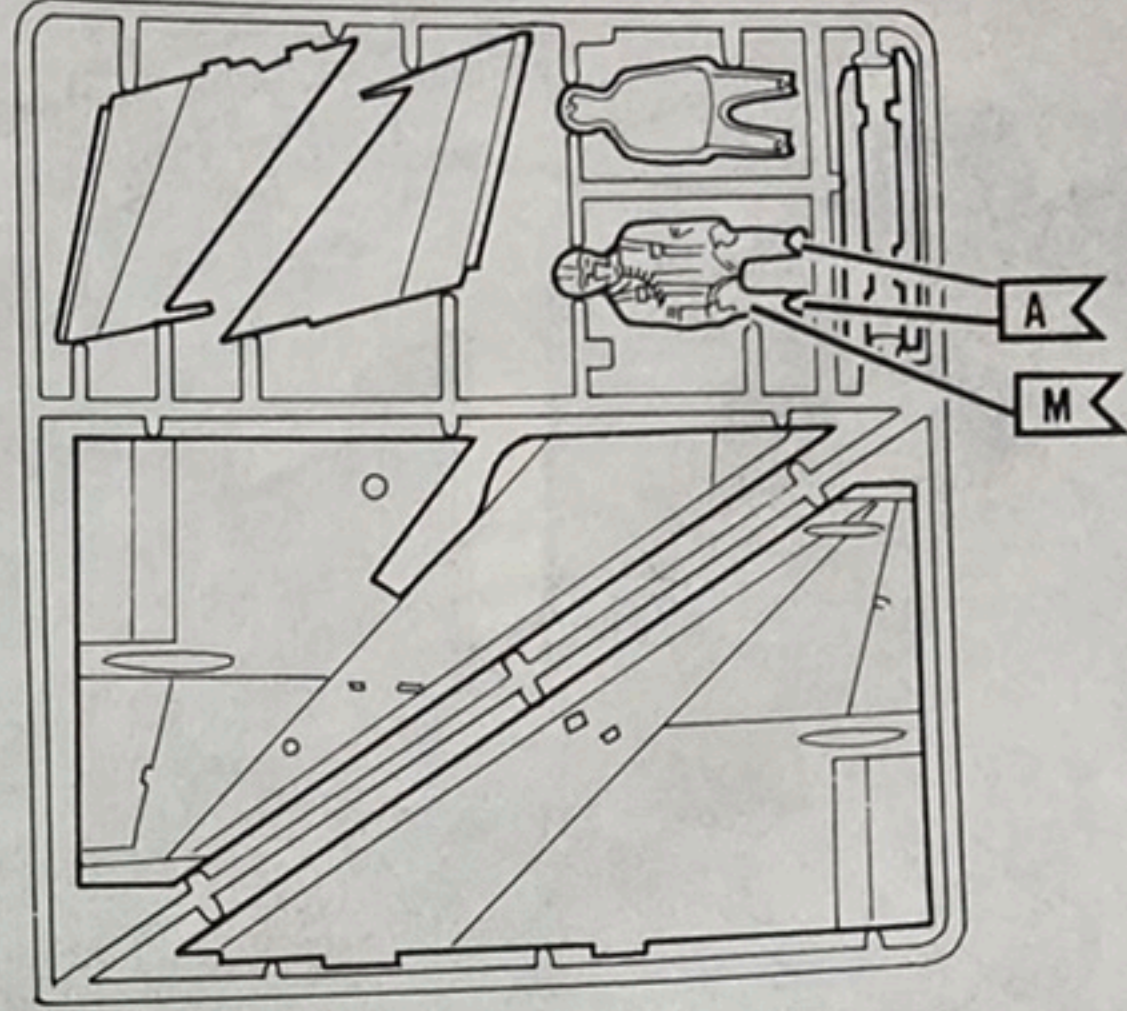
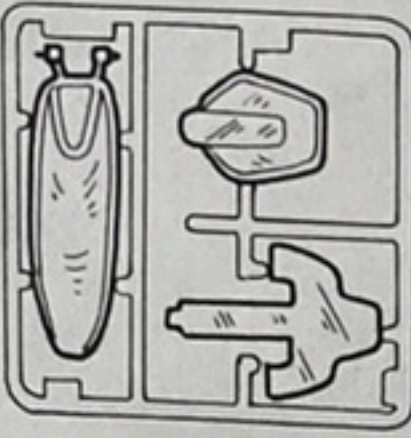
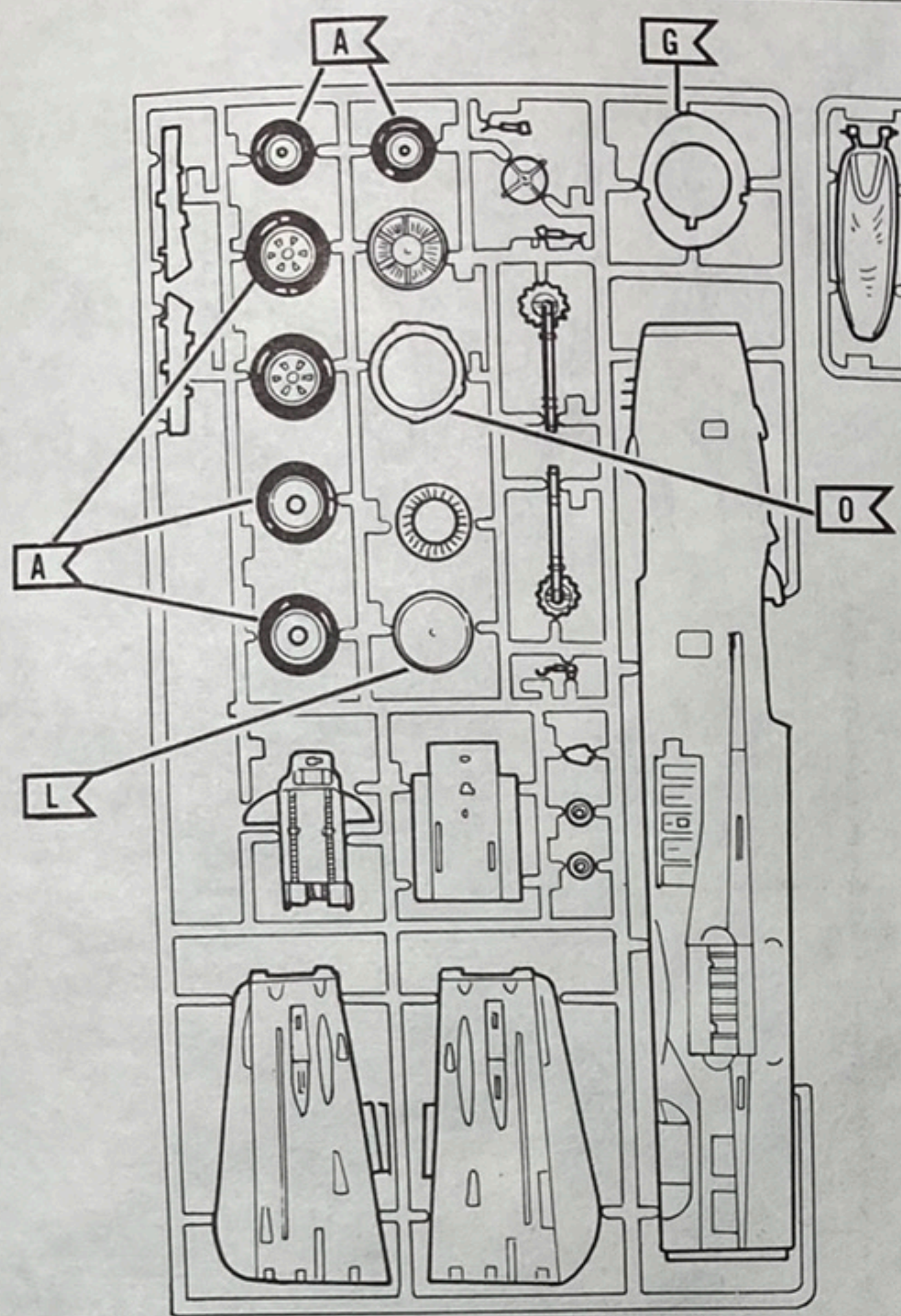

42

13 INSTRUMENT PANEL (CLEAR)

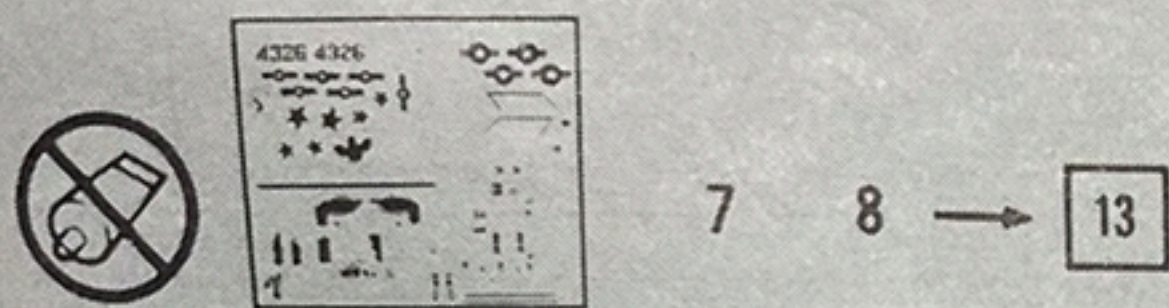
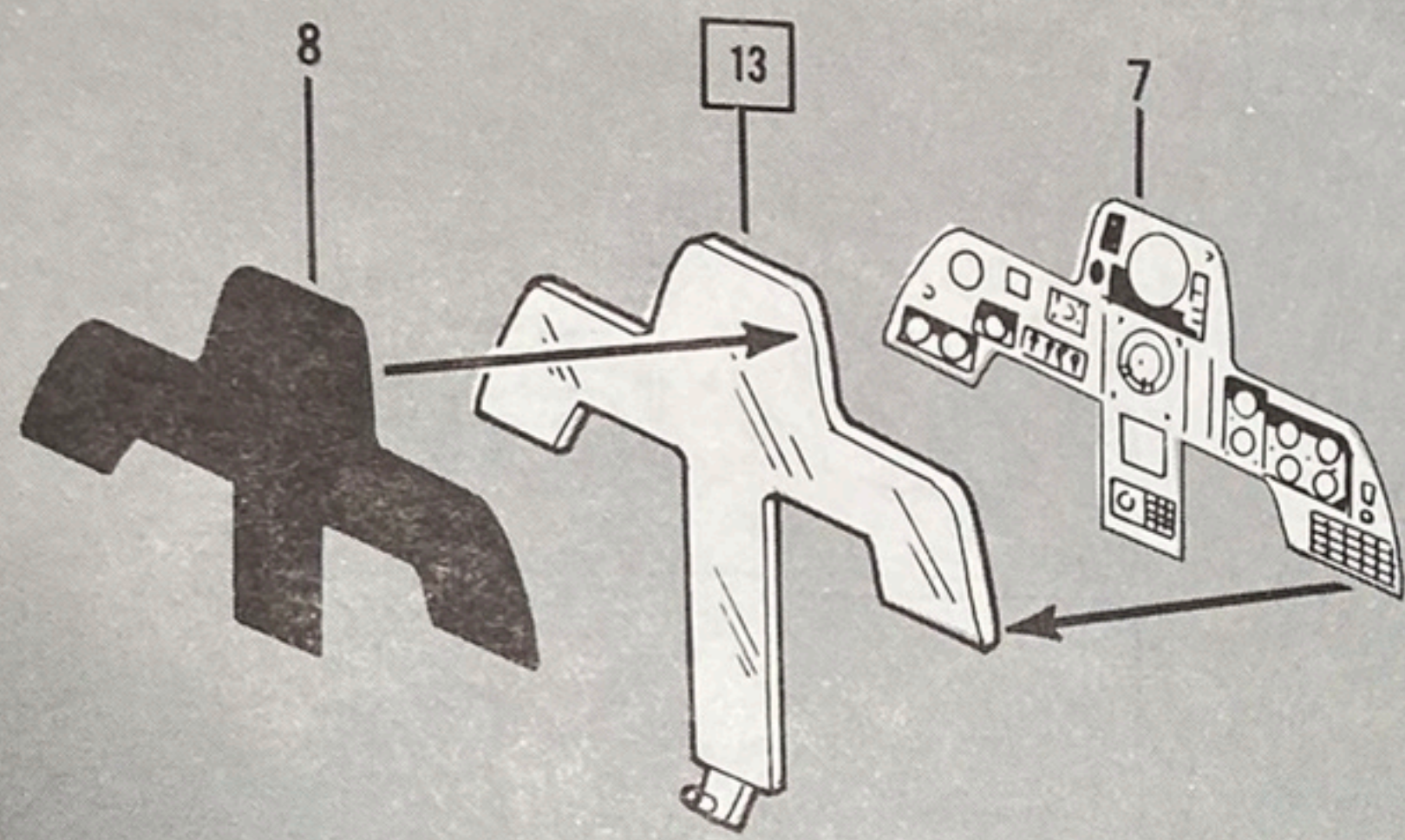

43

9 PILOT — FRONT HALF
10 PILOT — BACK HALF

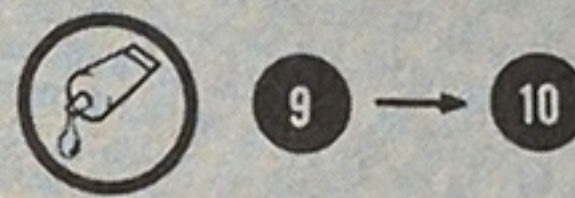
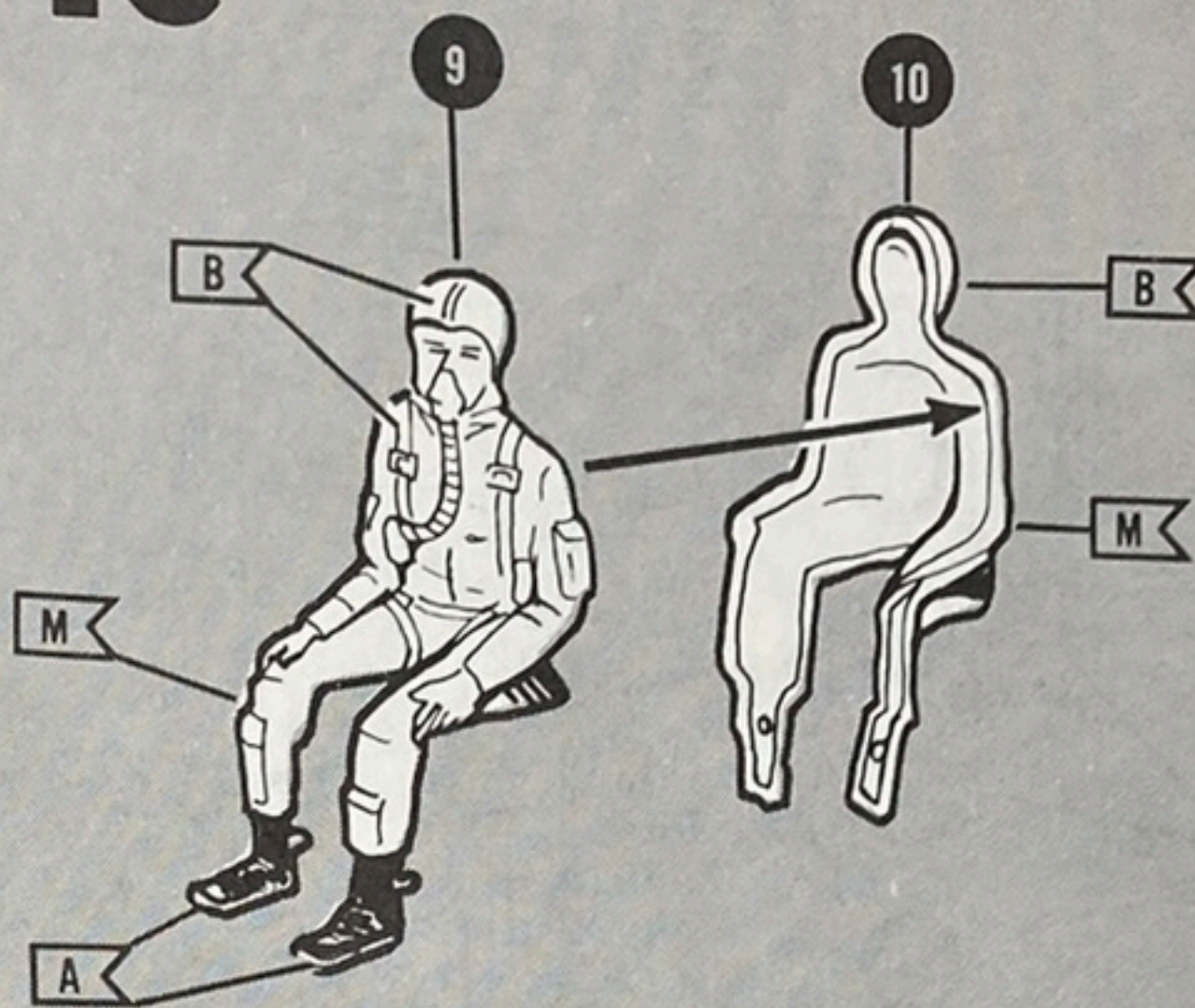

44

6 ARMOUR PLATE
7 PILOT SEAT

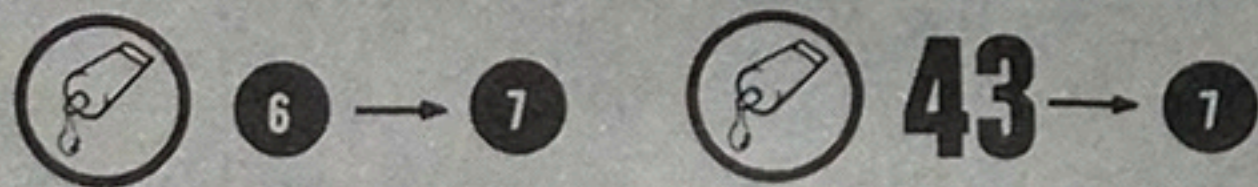
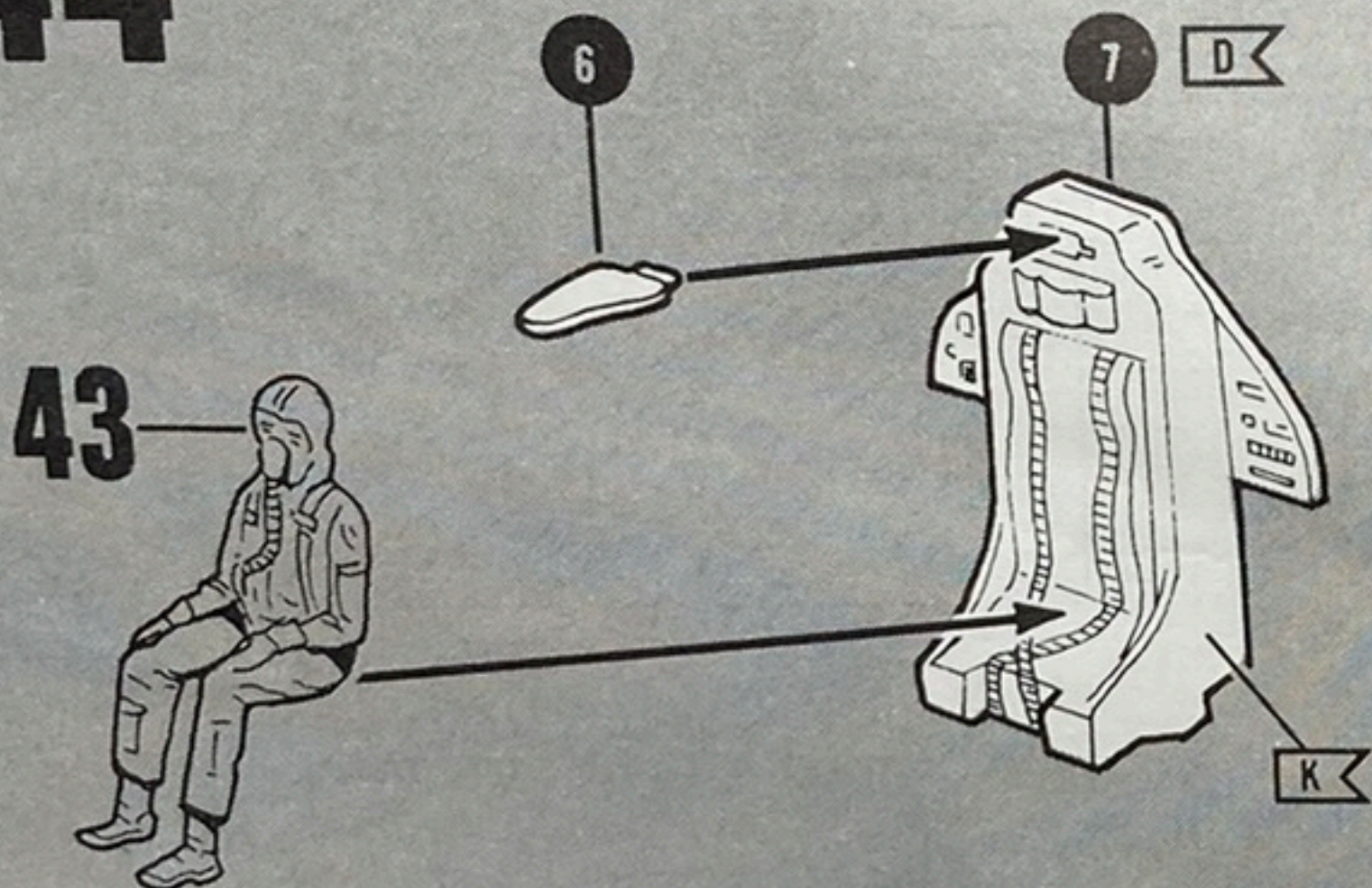

45

8 COCKPIT INTERIOR
11 CONTROL STICK
12 RUDDER PEDALS

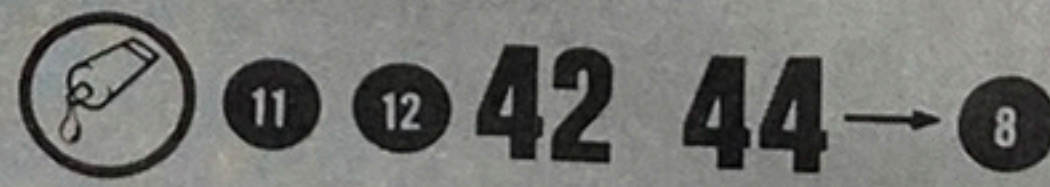
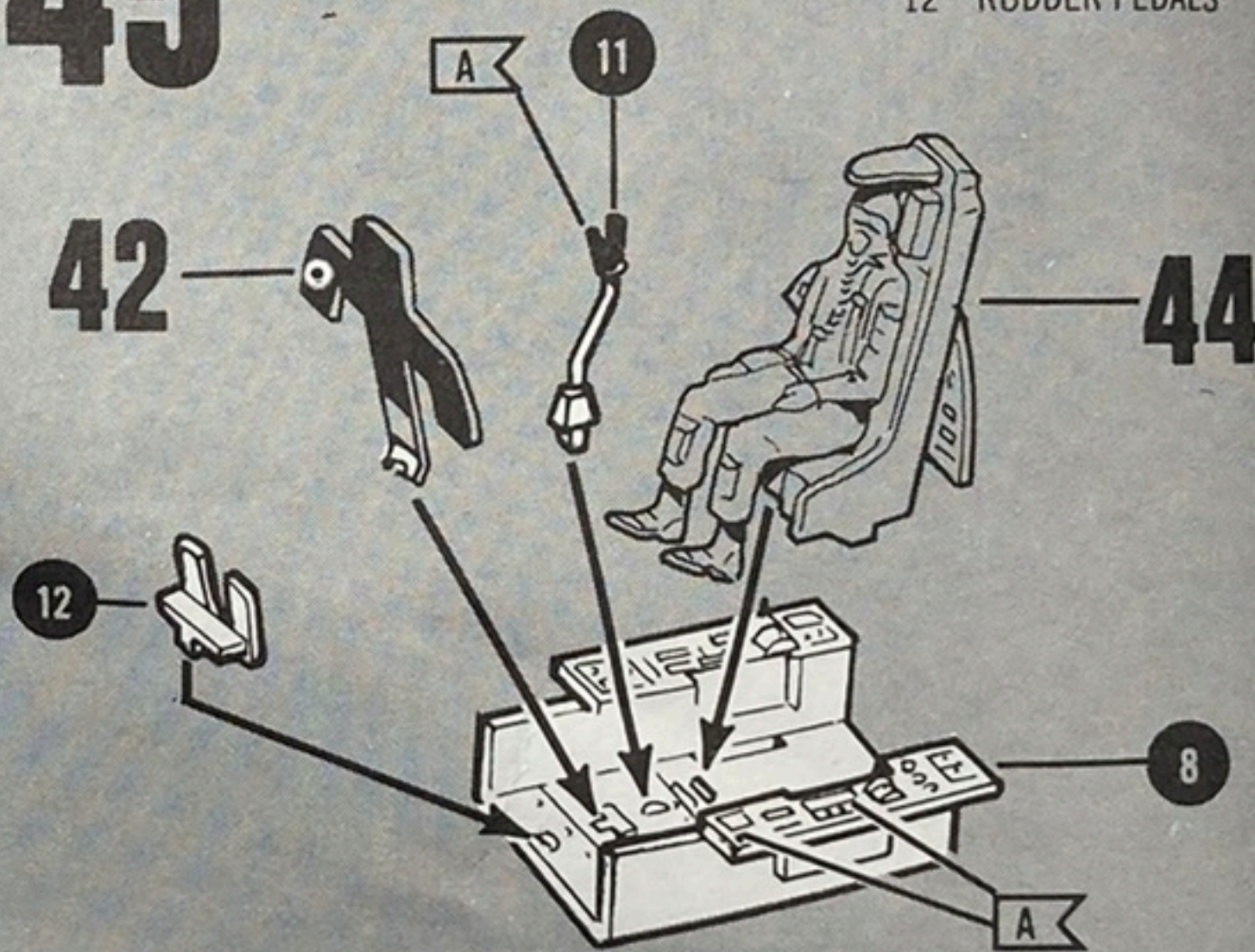

46

26 FORWARD FUSELAGE — RIGHT HALF
27 NOSE CONE
28 TURBOJET BULKHEAD

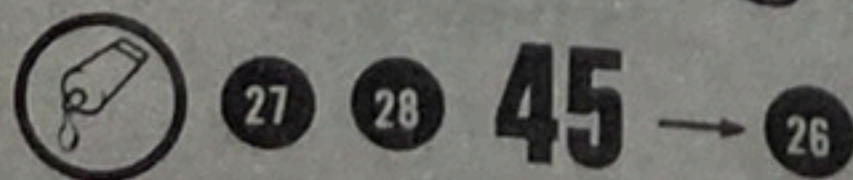
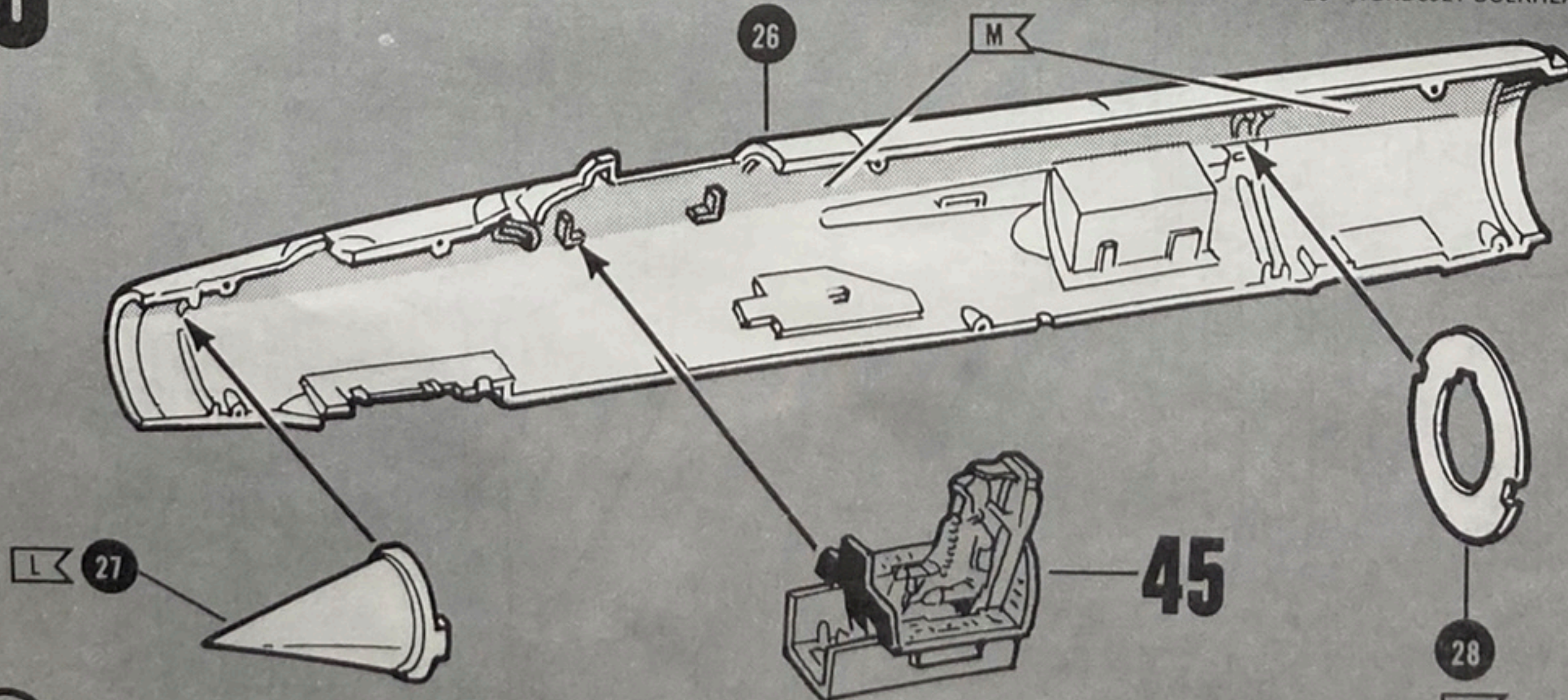

4747-3800

47

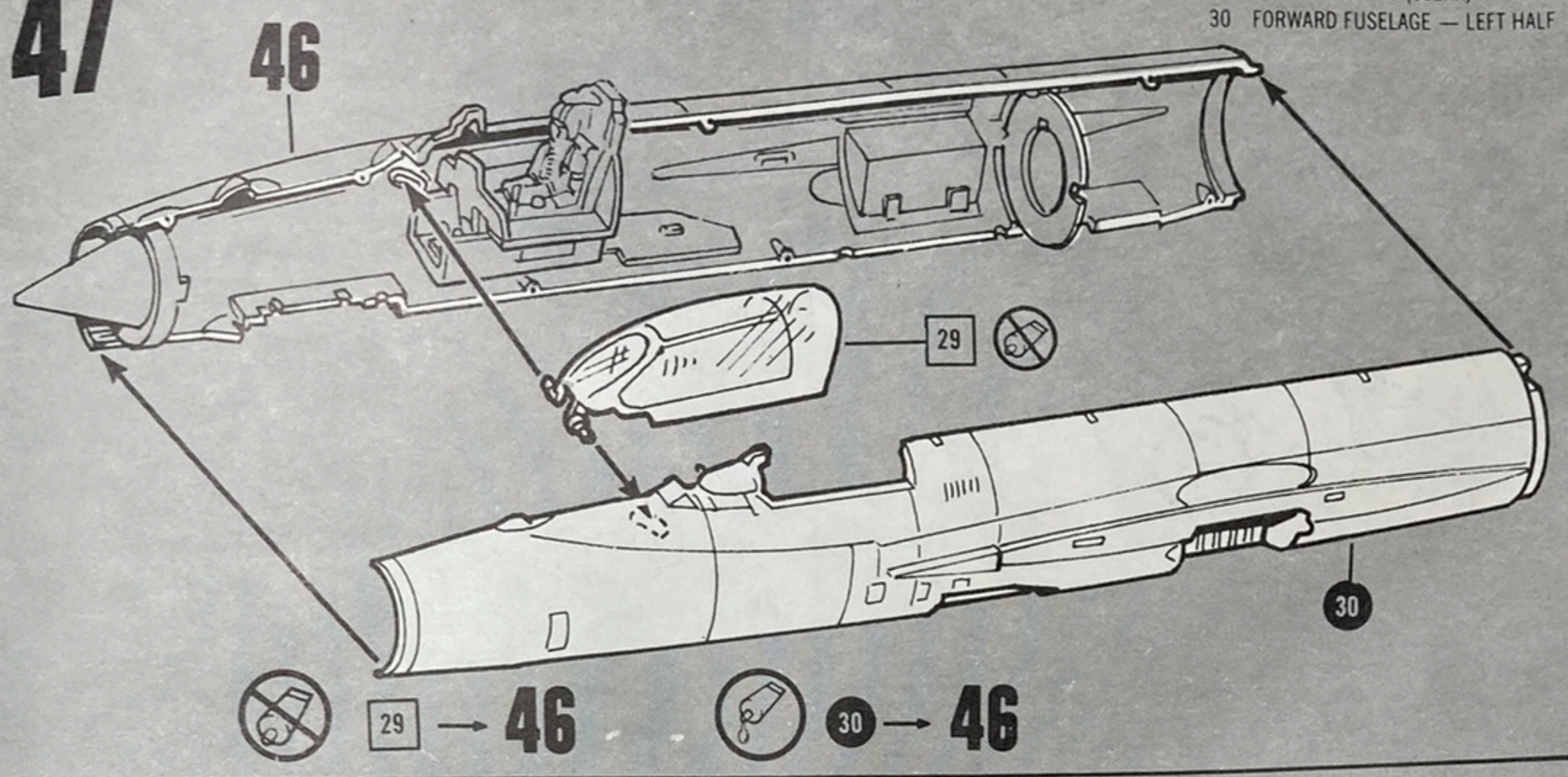

- 29 COCKPIT CANOPY (CLEAR)
- 30 FORWARD FUSELAGE — LEFT HALF

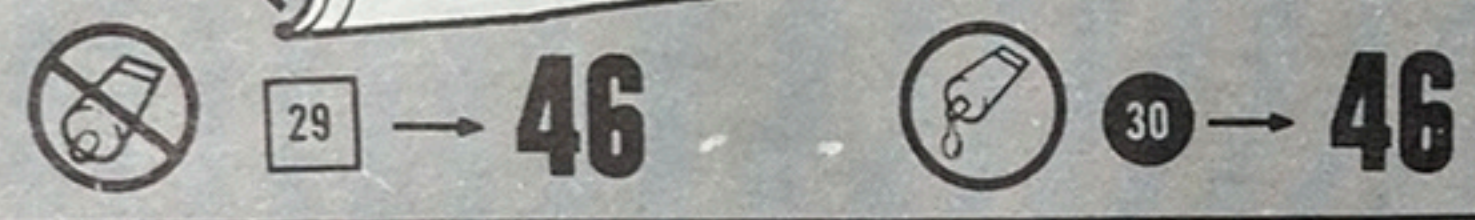

48

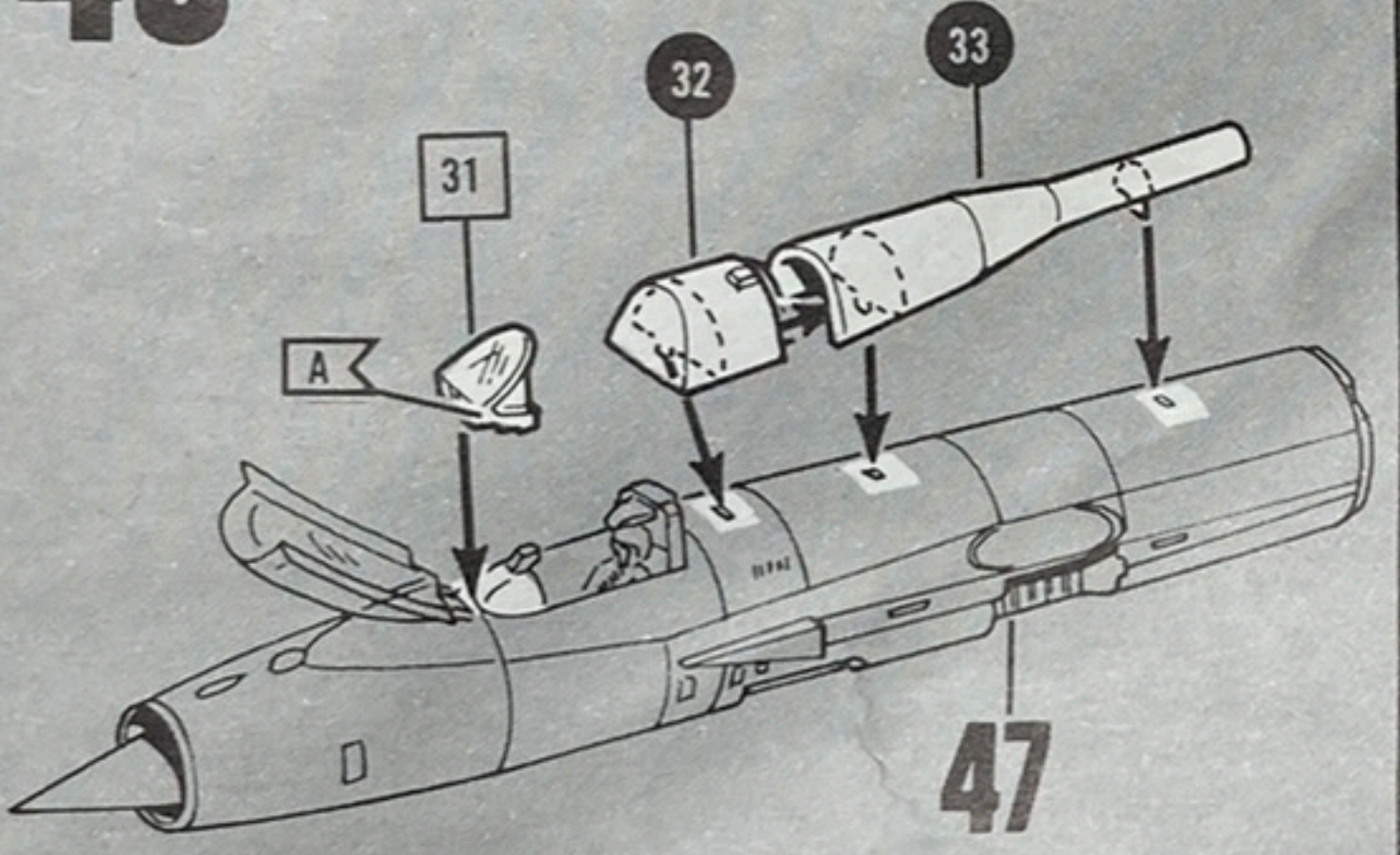

- 31 ARMOUR GLASS (CLEAR)
- 32 FRONT DORSAL FAIRING
- 33 DORSAL FAIRING

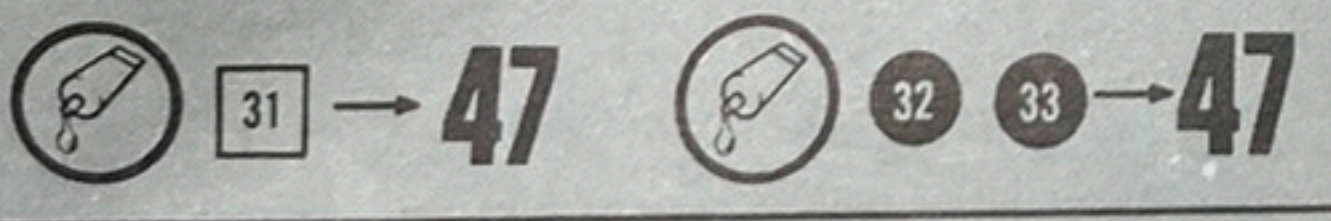

49

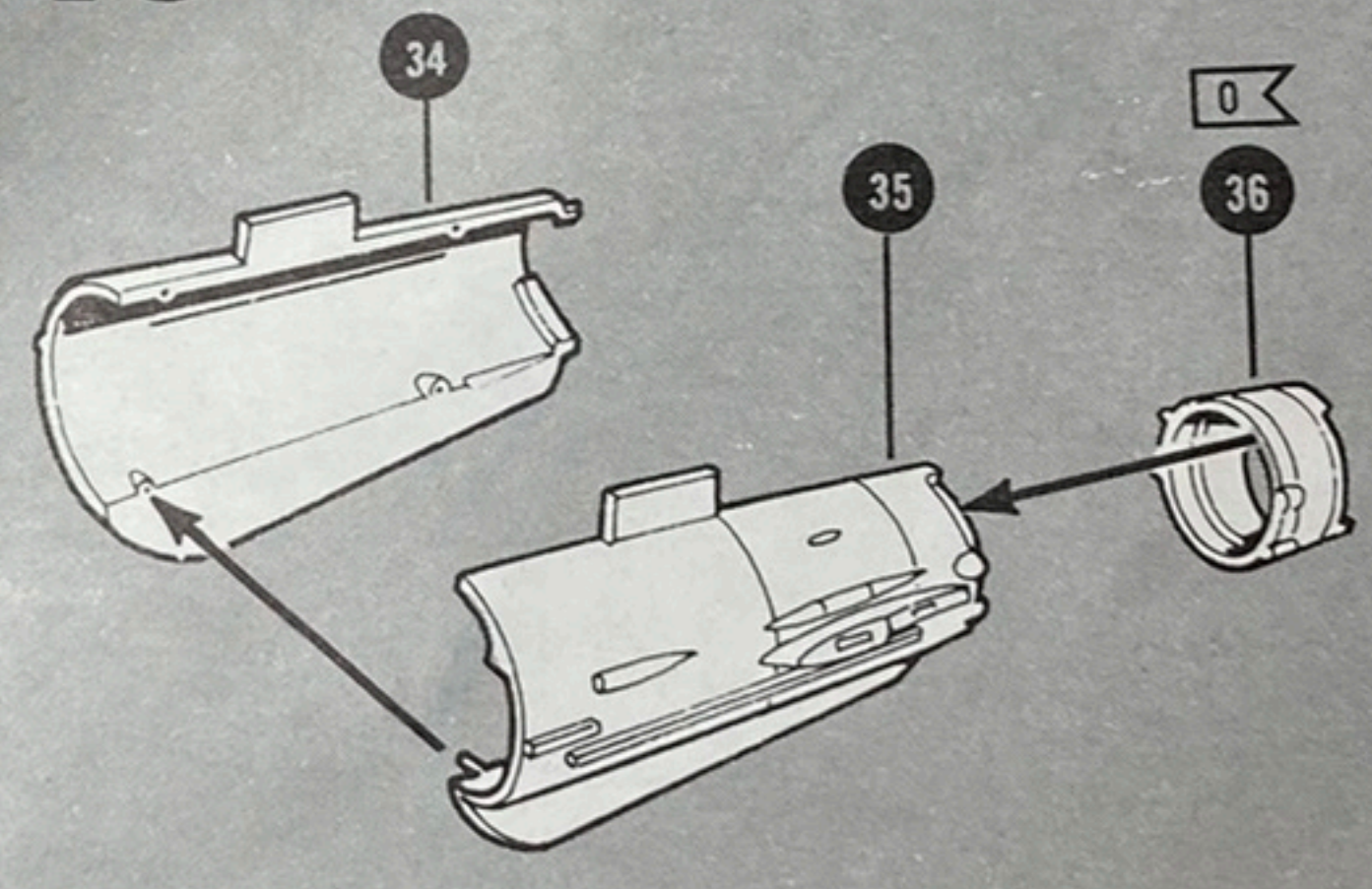

- 34 REAR FUSELAGE — RIGHT HALF
- 35 REAR FUSELAGE — LEFT HALF
- 36 TURBOJET TAIL SHROUD

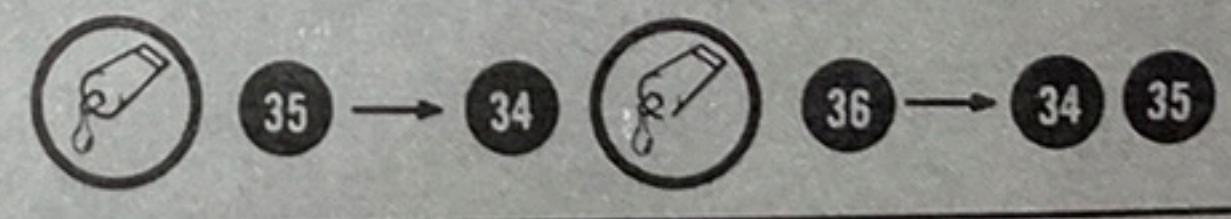

50

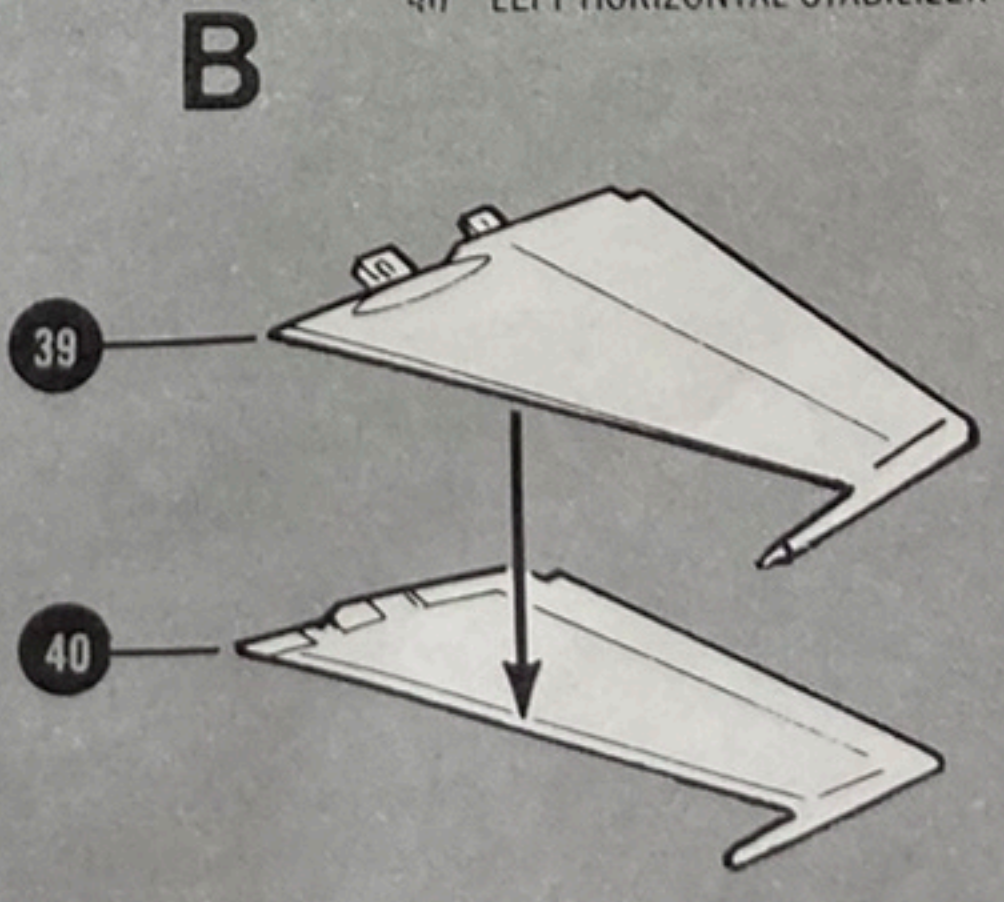
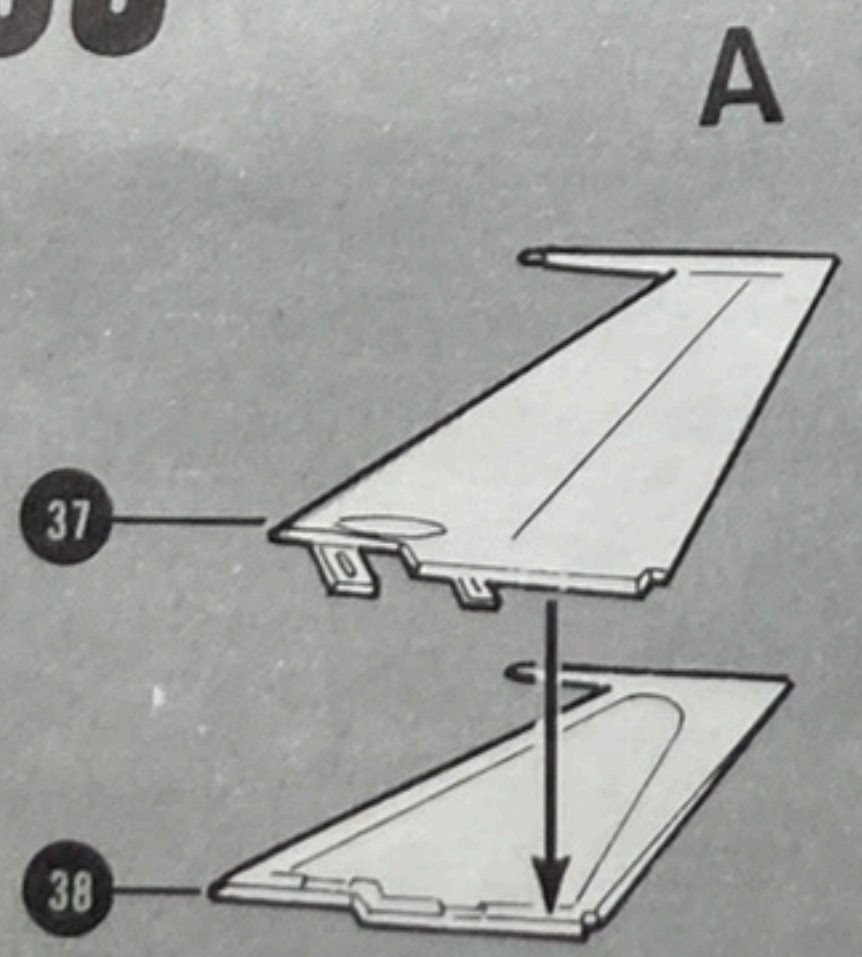

- 37 RIGHT HORIZONTAL STABILIZER — TOP HALF
- 38 RIGHT HORIZONTAL STABILIZER — BOTTOM HALF
- 39 LEFT HORIZONTAL STABILIZER — TOP HALF
- 40 LEFT HORIZONTAL STABILIZER — BOTTOM HALF

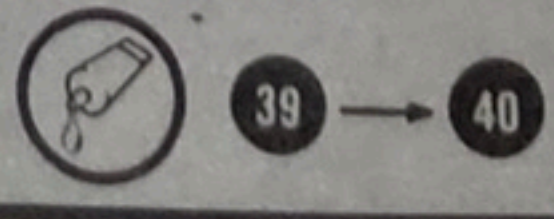
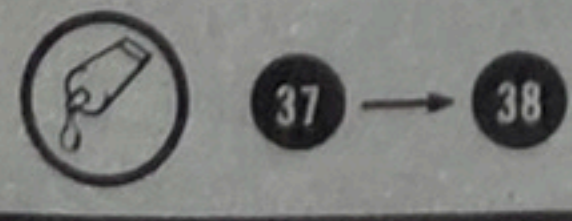

51

- 41 VERTICAL STABILIZER — RIGHT HALF (PF)
- 42 VERTICAL STABILIZER — LEFT HALF (PF)
- 43 VERTICAL STABILIZER — RIGHT HALF (LATE PF)
- 44 VERTICAL STABILIZER — LEFT HALF (LATE PF)

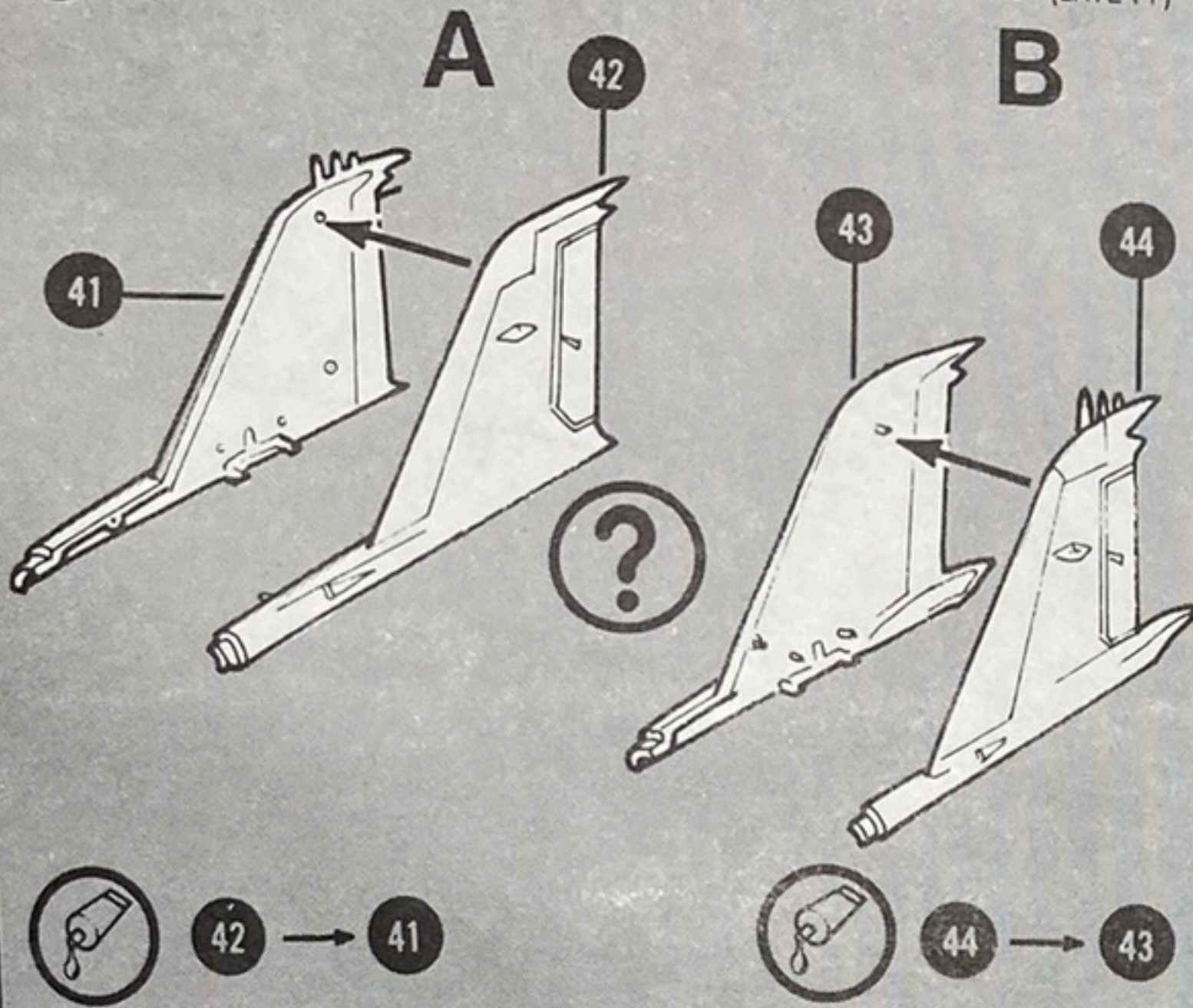

52

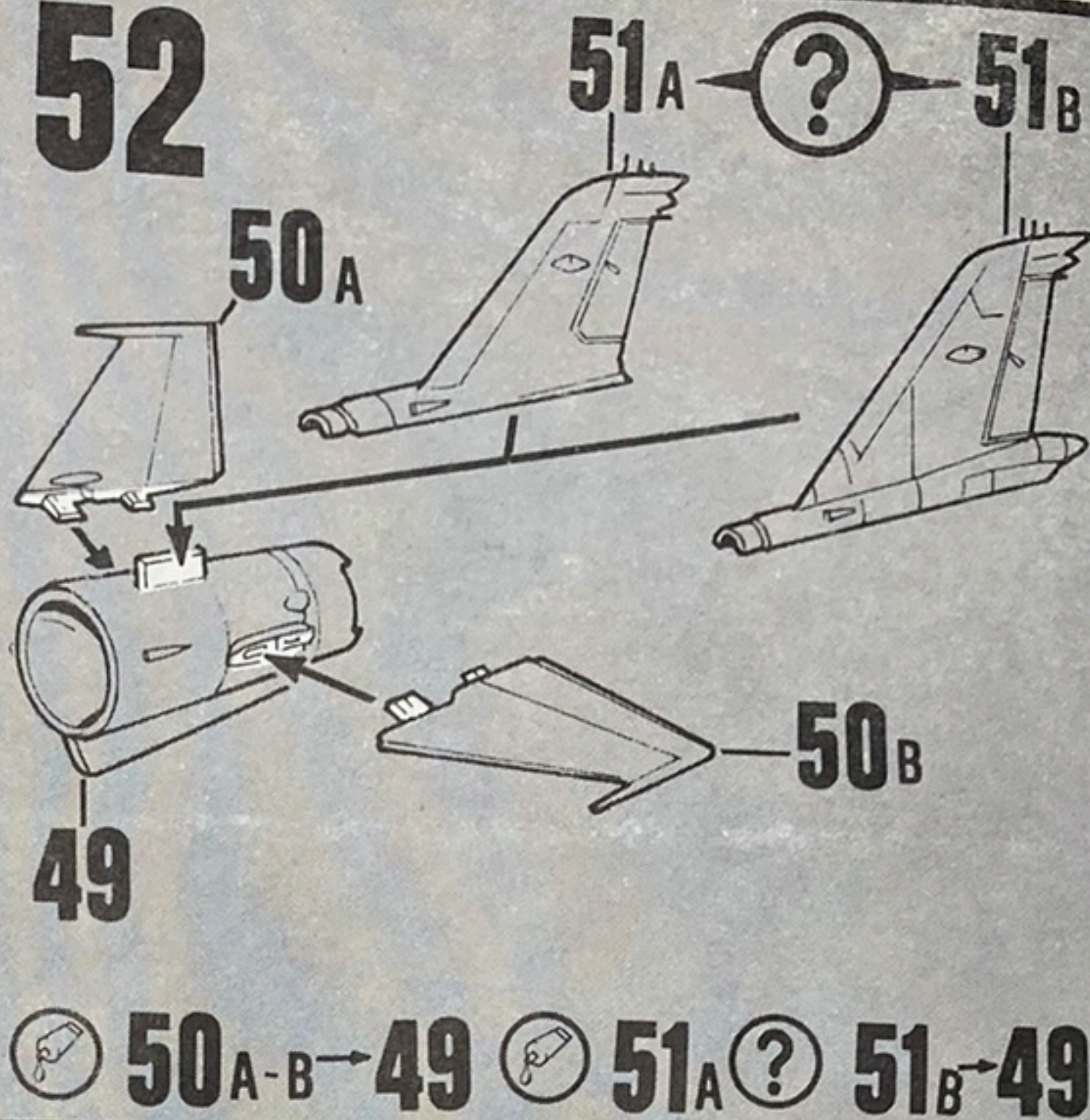

53

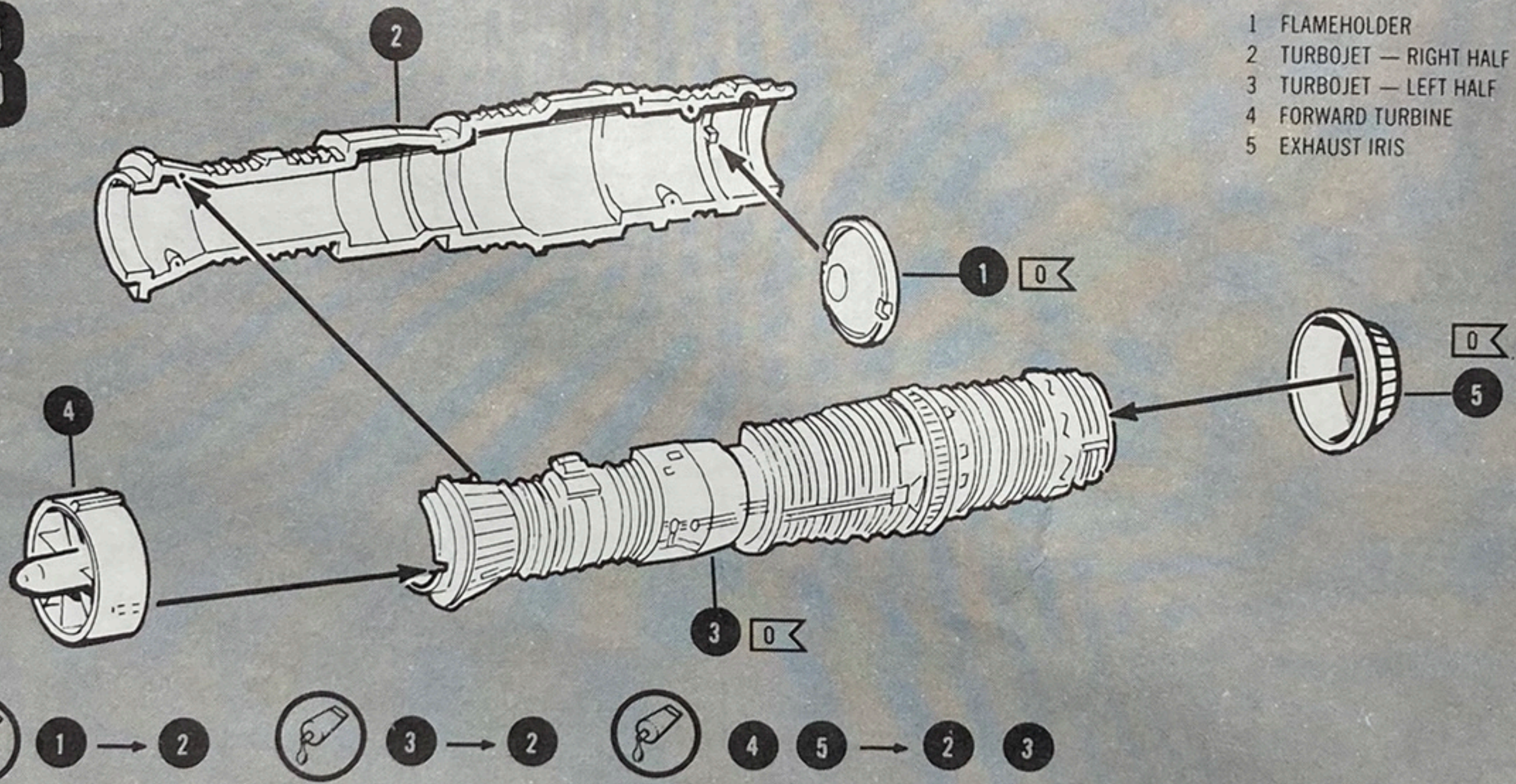

- 1 FLAMEHOLDER
- 2 TURBOJET — RIGHT HALF
- 3 TURBOJET — LEFT HALF
- 4 FORWARD TURBINE
- 5 EXHAUST IRIS

54

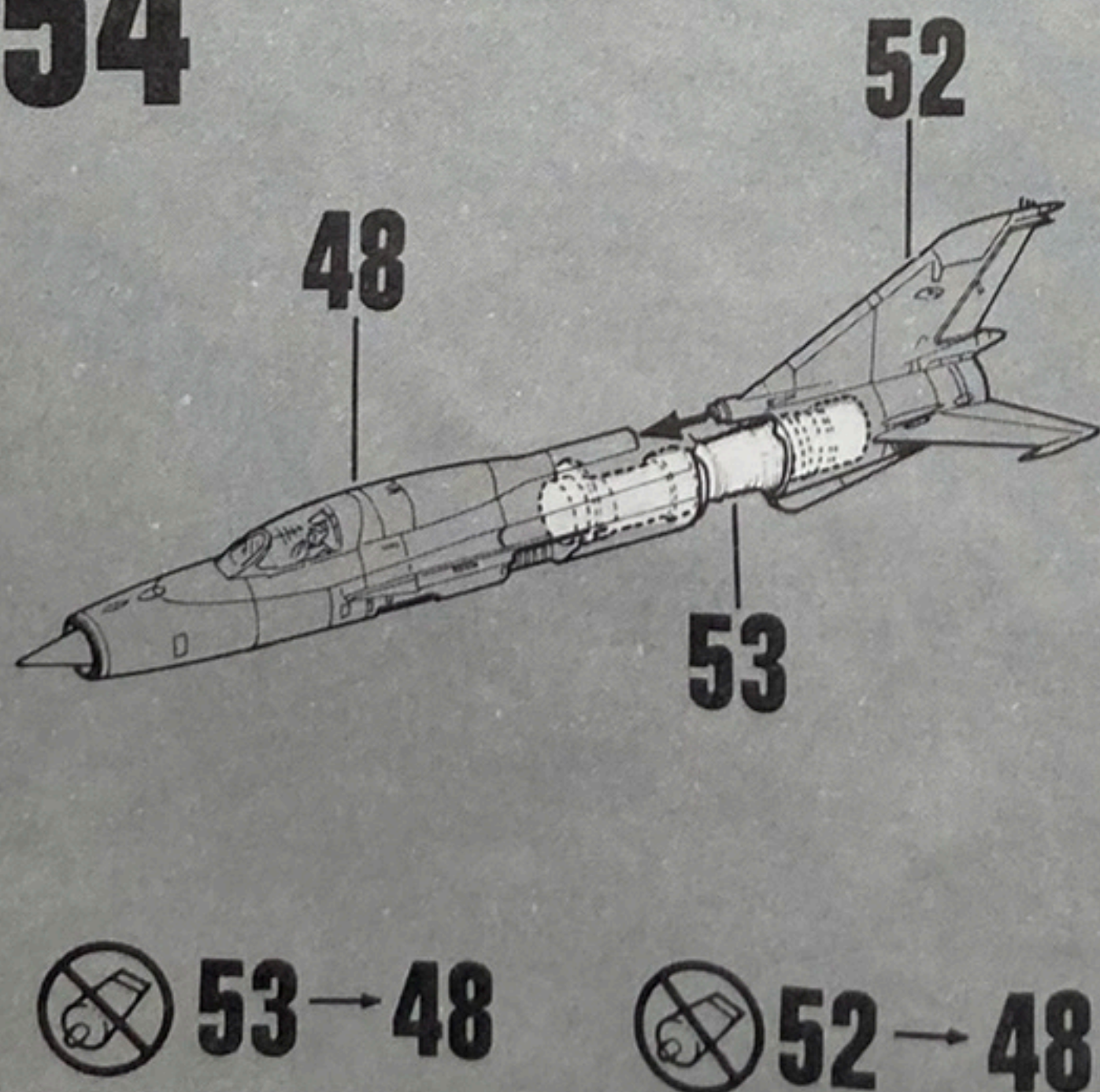

55

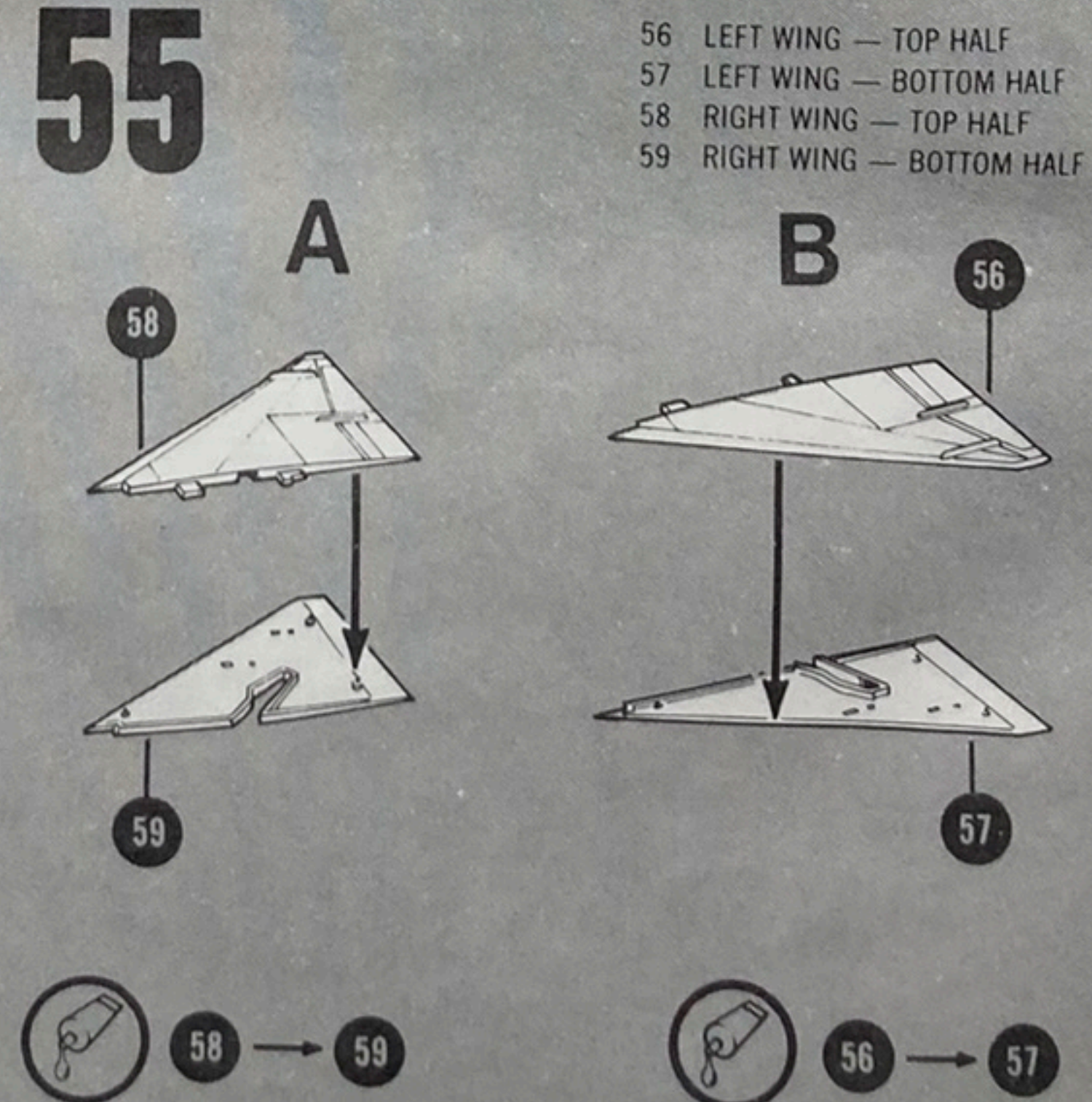

- 56 LEFT WING — TOP HALF
- 57 LEFT WING — BOTTOM HALF
- 58 RIGHT WING — TOP HALF
- 59 RIGHT WING — BOTTOM HALF

56

(A)

(?)

(B)

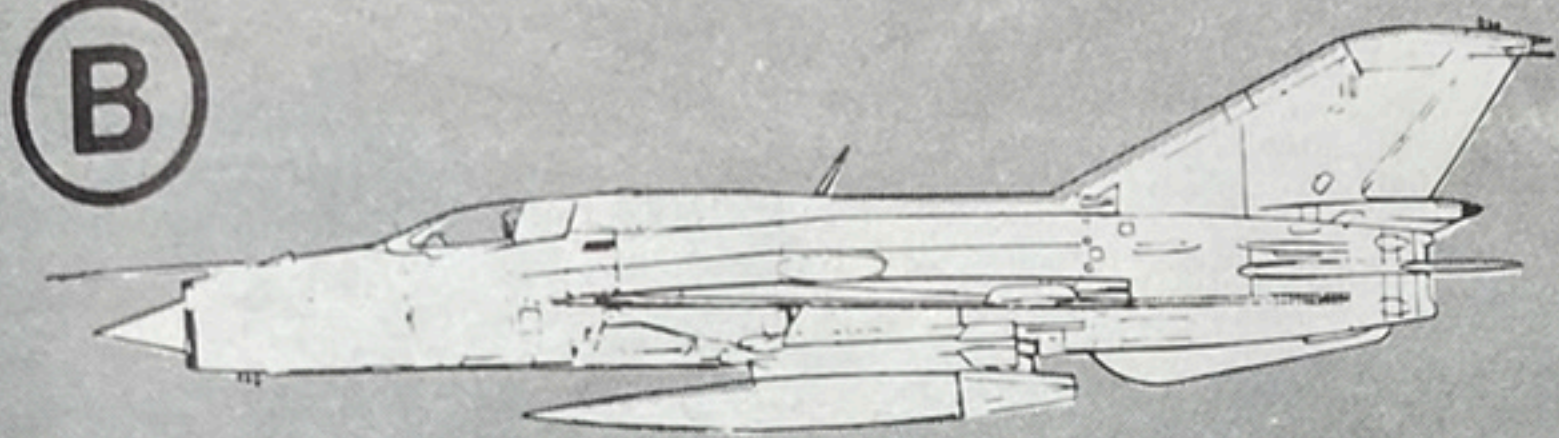
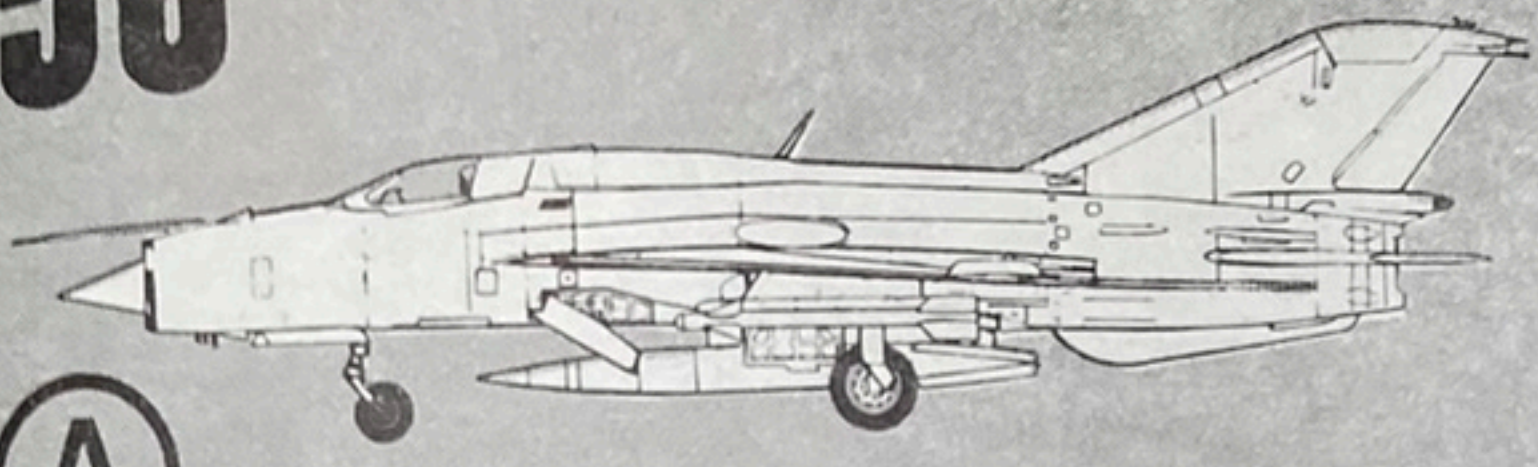

57

(B)

- 24 RIGHT MAIN GEAR STRUT DOOR
- 25 LEFT MAIN GEAR STRUT DOOR
- 60 NOSE GEAR RIGHT DOOR
- 61 NOSE GEAR LEFT DOOR
- 62 RIGHT MAIN GEAR WHEEL DOOR
- 63 LEFT MAIN GEAR WHEEL DOOR
- 67 FORWARD SPEEDBRAKE — RIGHT
- 68 FORWARD SPEEDBRAKE — LEFT
- 70 REAR SPEEDBRAKE



Remove
Öter
Rimuovere

54

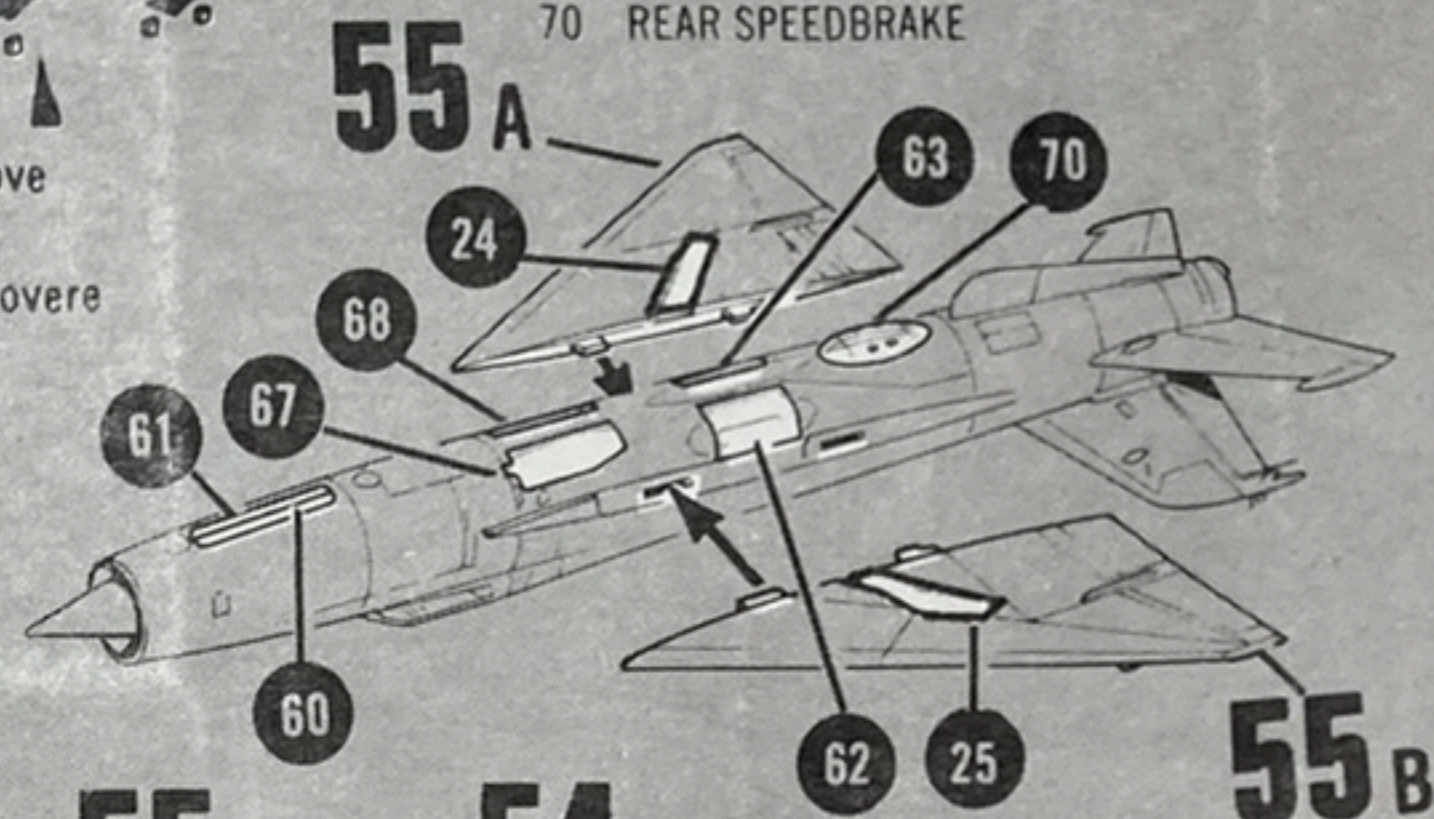

55 A

55 B



55 A-B → 54



24 25 60 61 62 63 67 68 70 → 54

58

(A)

- 14 NOSE WHEEL — RIGHT HALF
- 15 NOSE WHEEL — LEFT HALF
- 16 NOSE GEAR STRUT — RIGHT HALF
- 17 NOSE GEAR STRUT — LEFT HALF

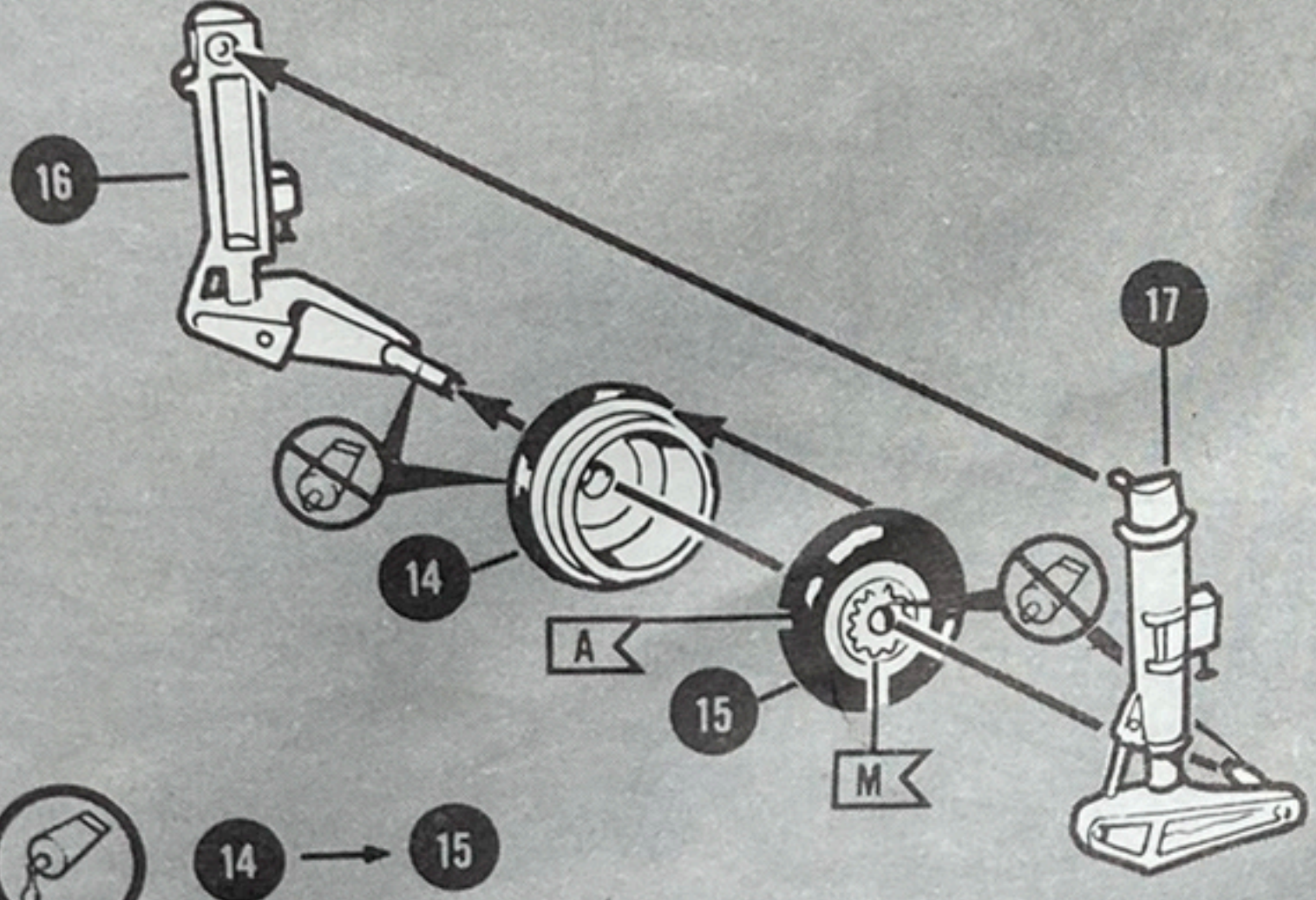

14 → 15



14 15 → 16



17 → 16

59

- 60 NOSE GEAR RIGHT DOOR
- 61 NOSE GEAR LEFT DOOR

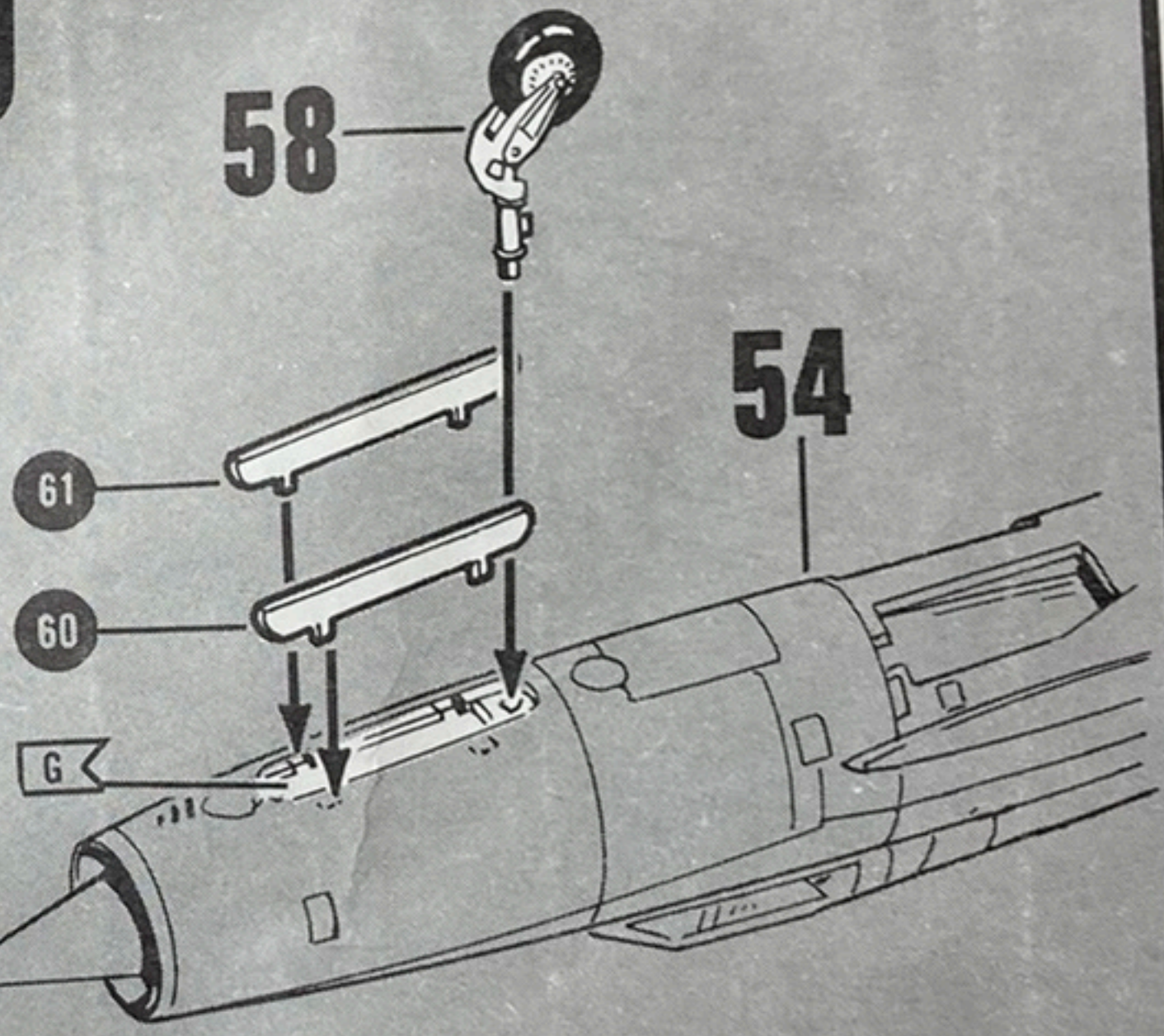

58 → 54



60 61 → 54

60

- 18 MAIN GEAR STRUT SCISSORS (2 PARTS)
- 19 RIGHT MAIN GEAR STRUT
- 20 LEFT MAIN GEAR STRUT
- 21 WHEEL RETAINER (2 PARTS)
- 22 WHEEL — OUTSIDE HALF (2 PARTS)
- 23 WHEEL — INSIDE HALF (2 PARTS)
- 24 RIGHT MAIN GEAR STRUT DOOR
- 25 LEFT MAIN GEAR STRUT DOOR

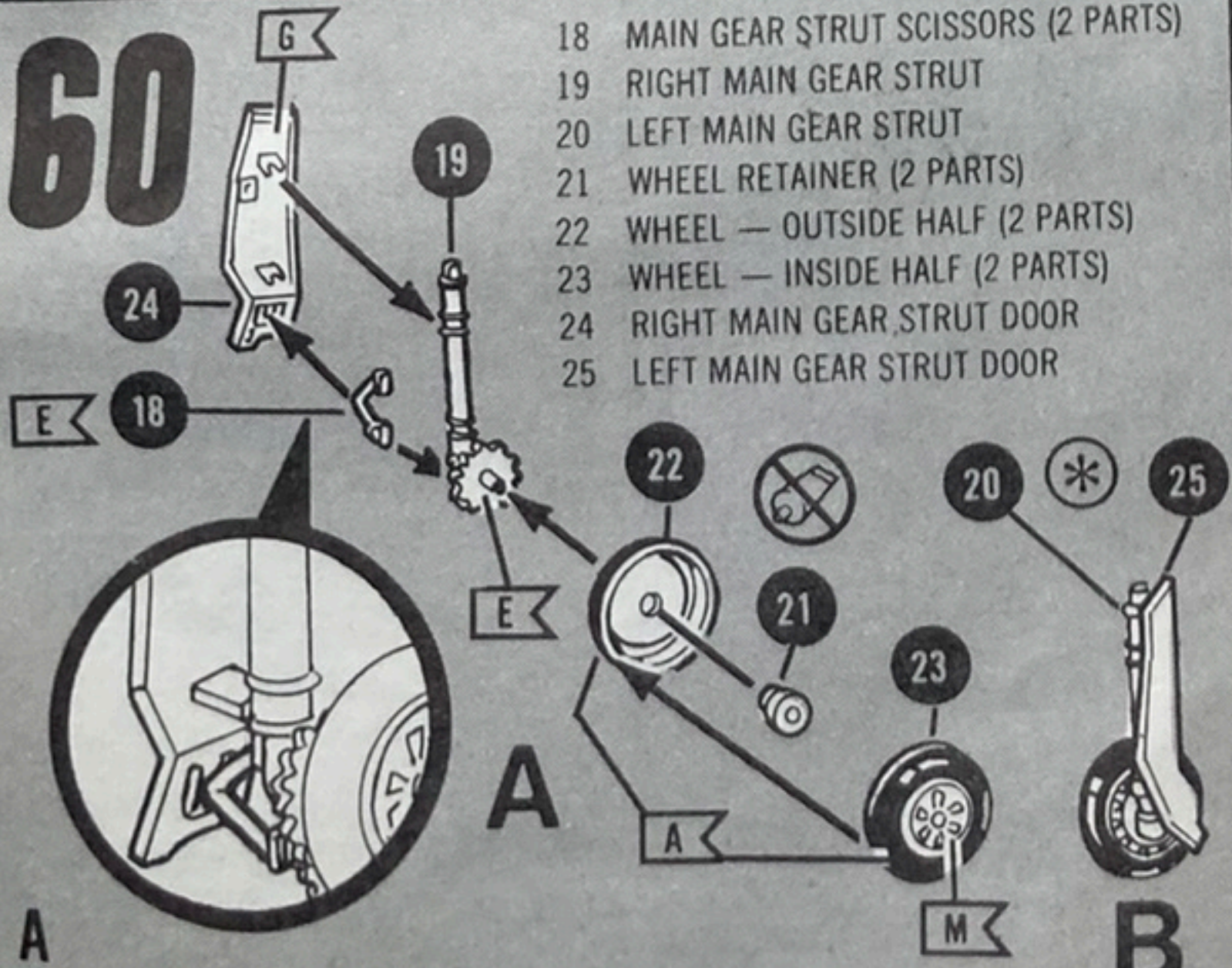

A

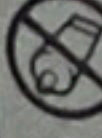

21 → 22

21 → 19



23 → 22

18 24 → 19

B



21

22

21 → 20



23 → 22

18 25 → 20

61

- 63 LEFT MAIN GEAR WHEEL DOOR
- 64 GEAR RETRACT LINK (2 PARTS)

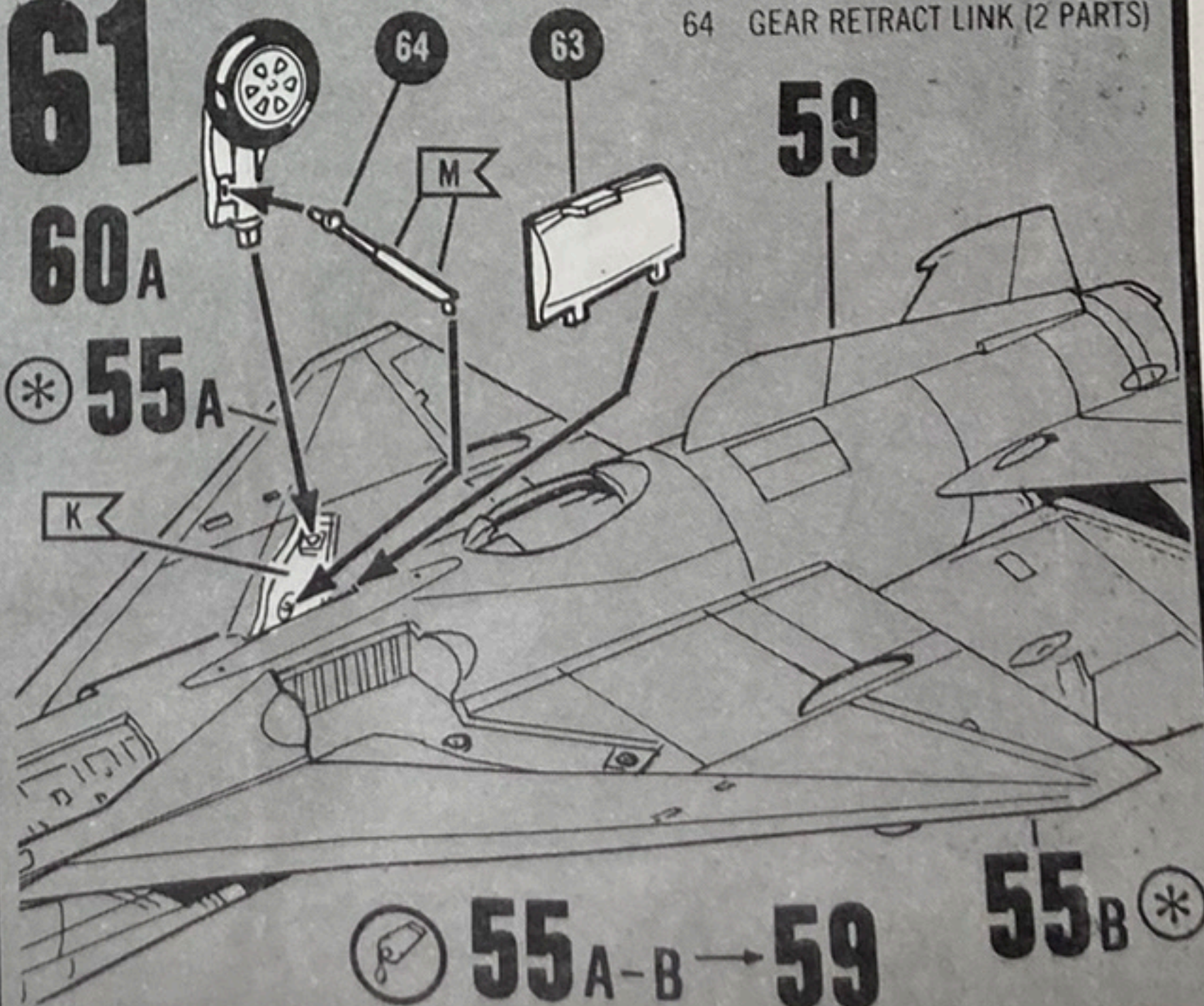

* 55 A

59

55 B *



55 A-B → 59



60 A 63 → 59



64 → 59

60 A

62

(A)

- 62 RIGHT MAIN GEAR WHEEL DOOR
- 64 GEAR RETRACT LINK (2 PARTS)

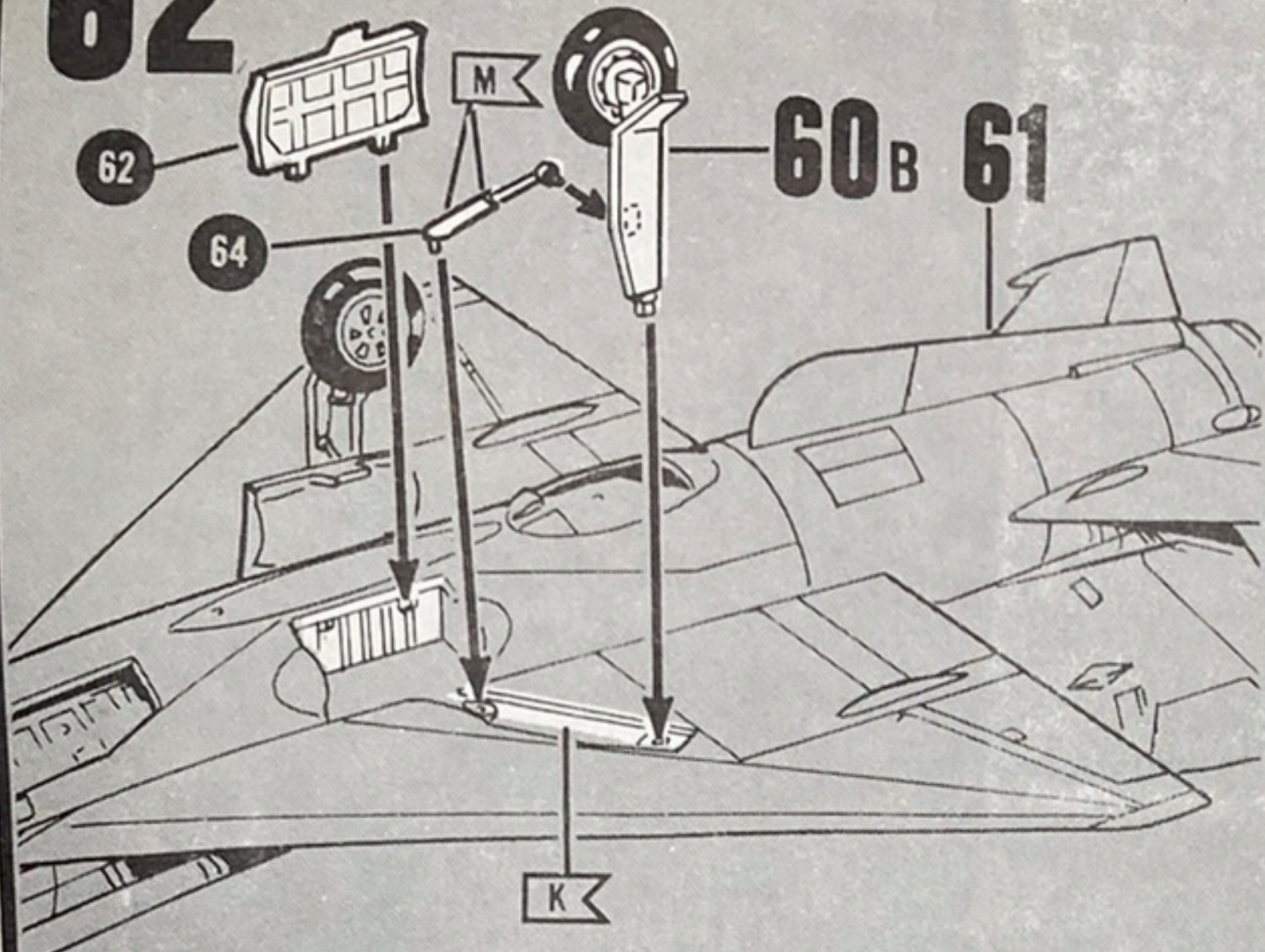

63

(2X)

- 45 MISSILE FIN — FORWARD (2 PARTS)
- 46 MISSILE HALF (2 PARTS)
- 47 MISSILE HALF WITH FIN (2 PARTS)
- 48 MISSILE FIN — REAR (2 PARTS)

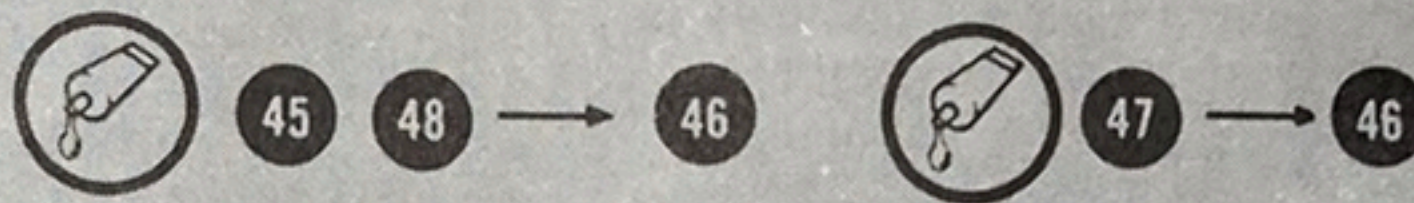
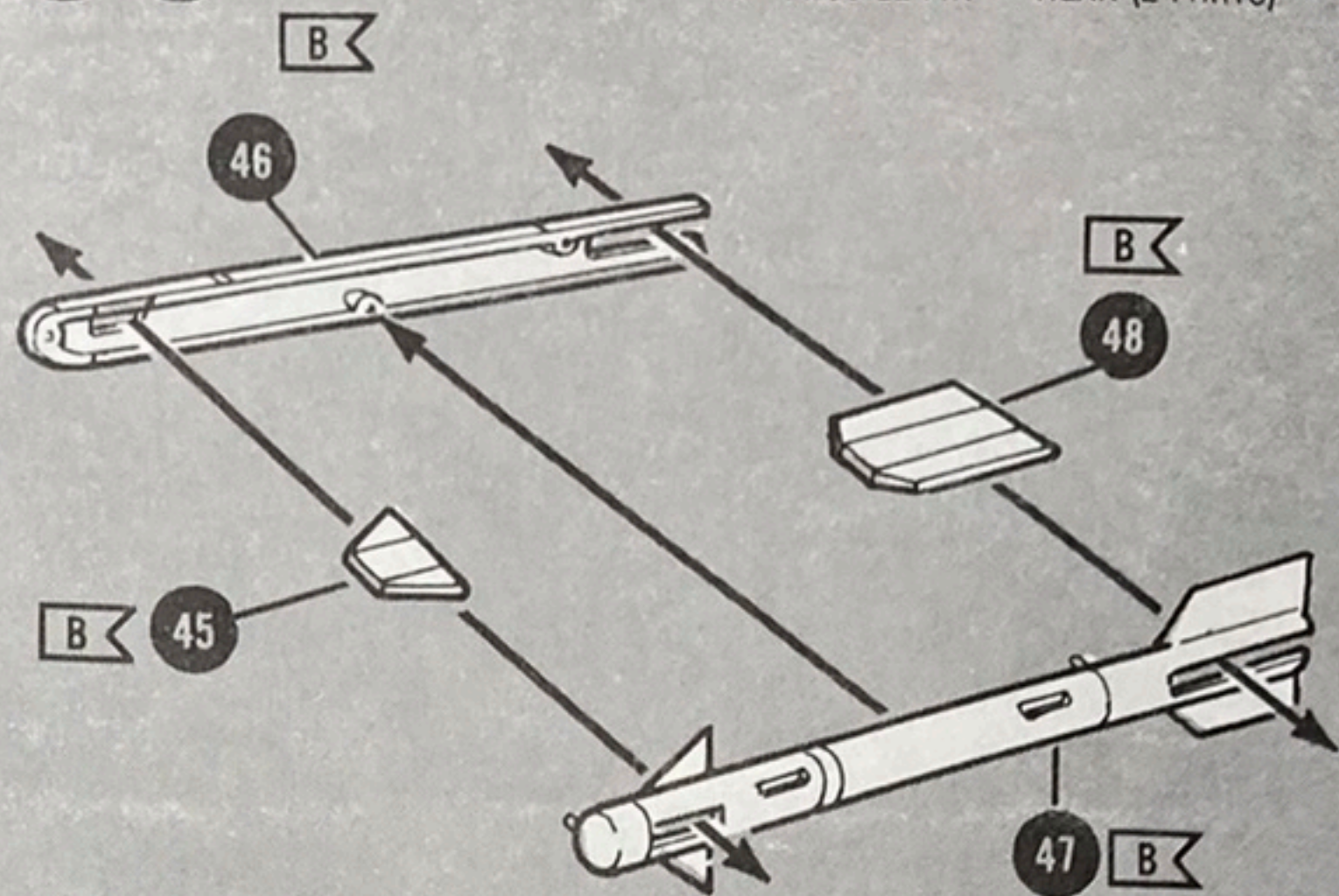

64

(A)

- 49 MISSILE RAIL (2 PARTS)
- 50 RIGHT MISSILE PYLON
- 51 LEFT MISSILE PYLON

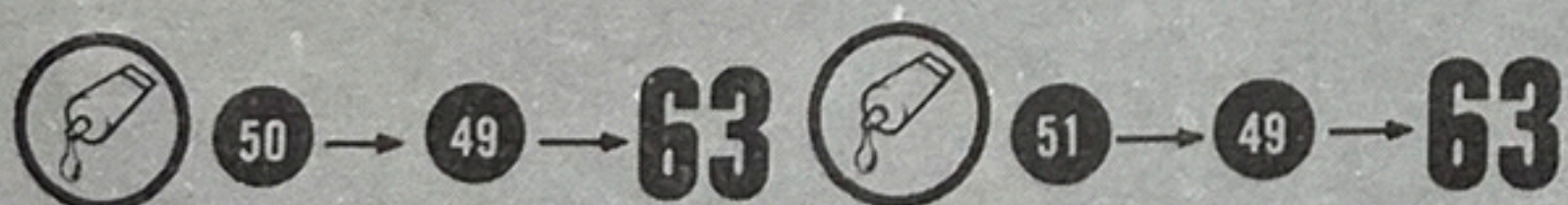
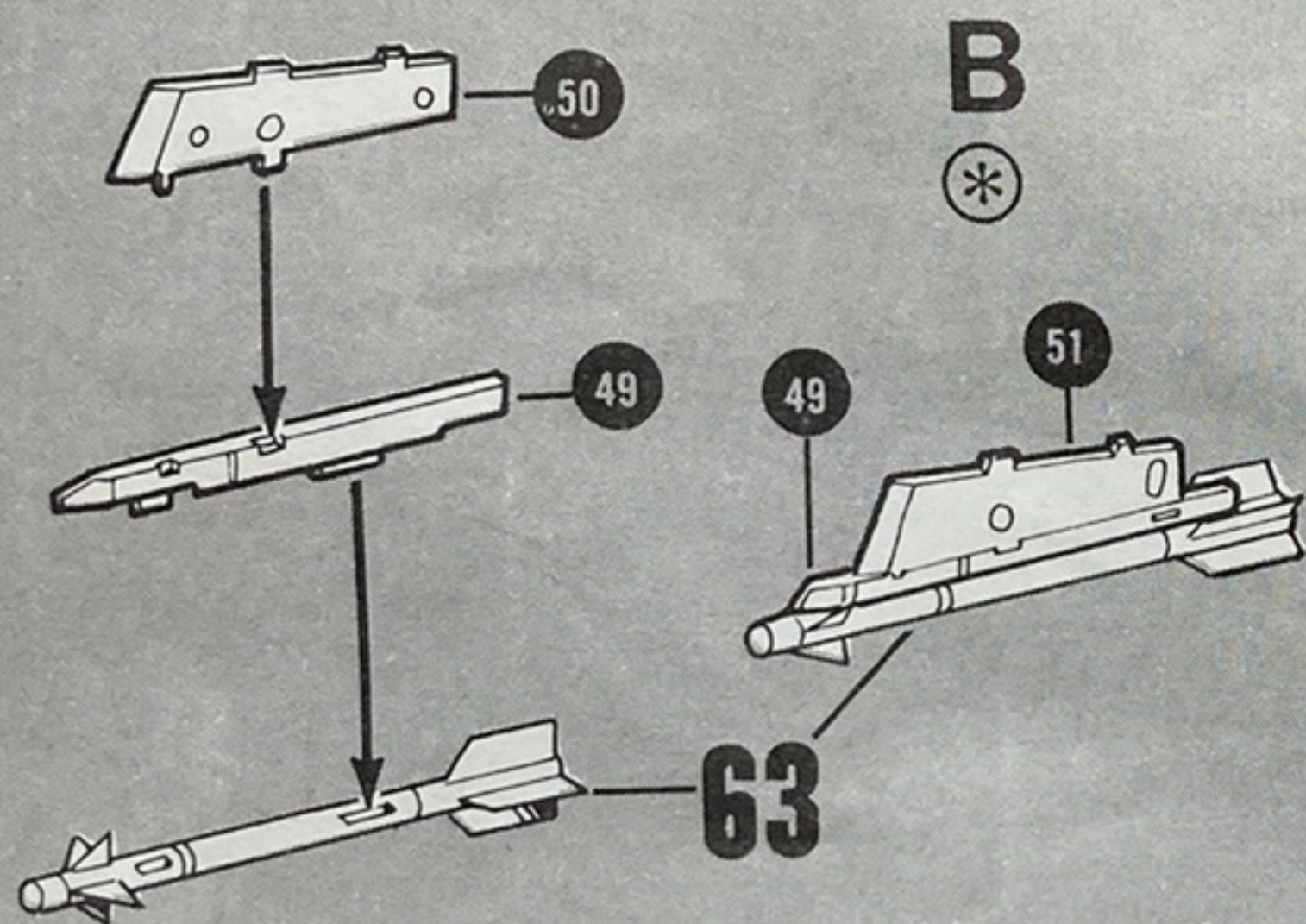

65

- 52 FUEL TANK — RIGHT HALF
- 53 FUEL TANK — LEFT HALF
- 54 FUEL TANK — REAR CAP
- 55 FUEL TANK RACK

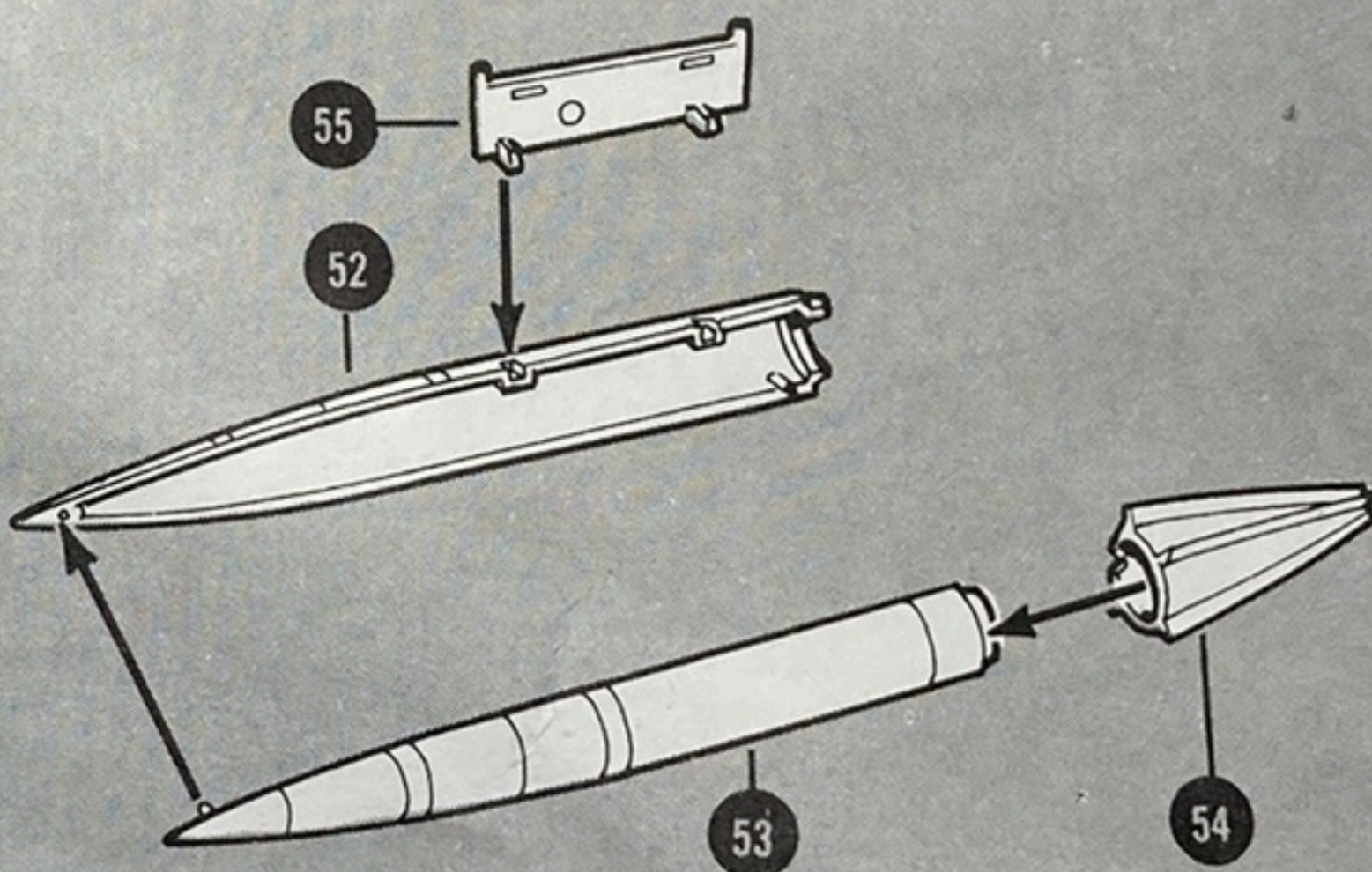

66

- 67 FORWARD SPEED BRAKE — RIGHT
- 68 FORWARD SPEED BRAKE — LEFT
- 69 FORWARD SPEED BRAKE RETRACT LINK (2 PARTS)
- 70 REAR SPEED BRAKE
- 71 REAR SPEED BRAKE RETRACT LINK

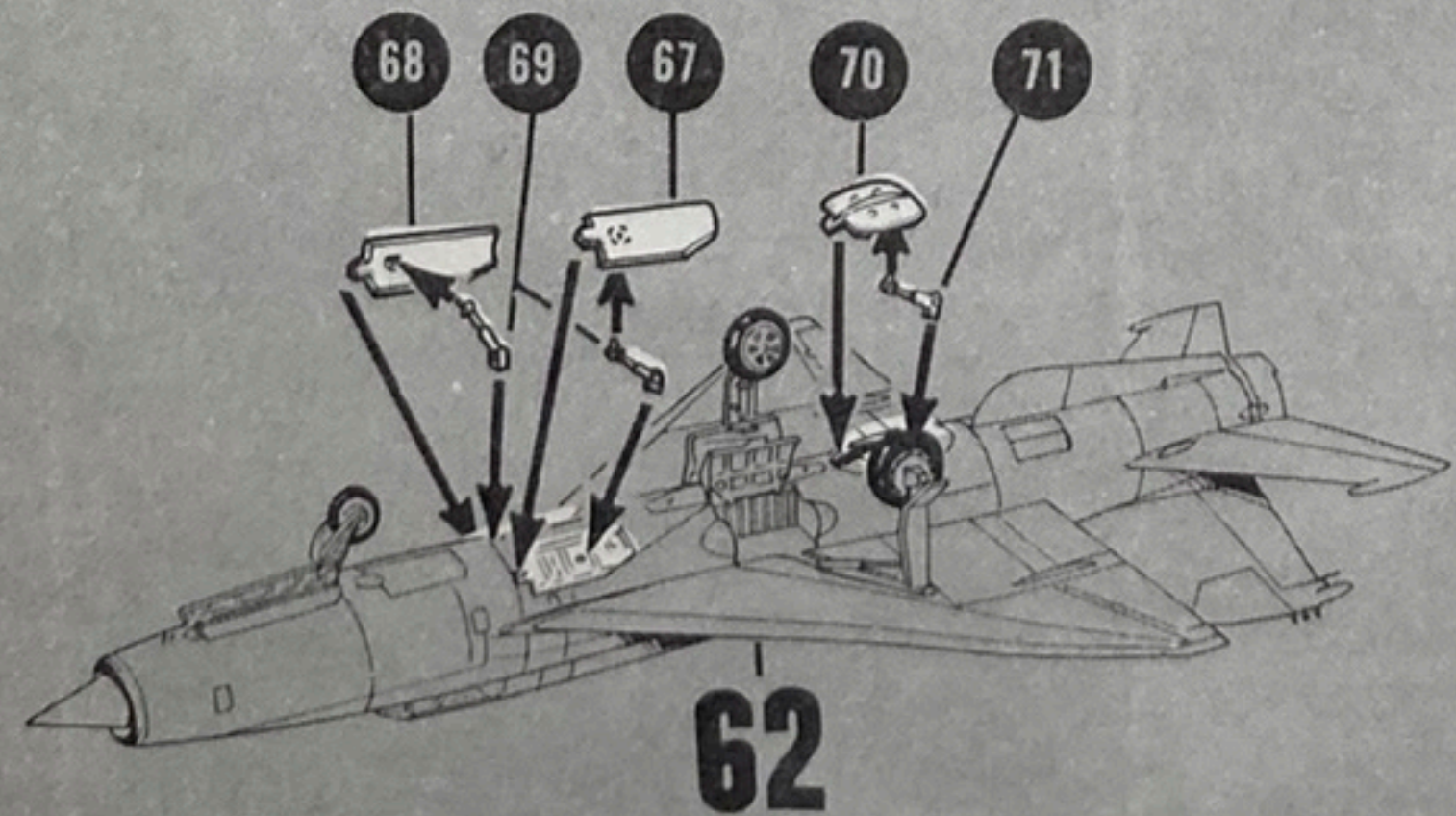

67



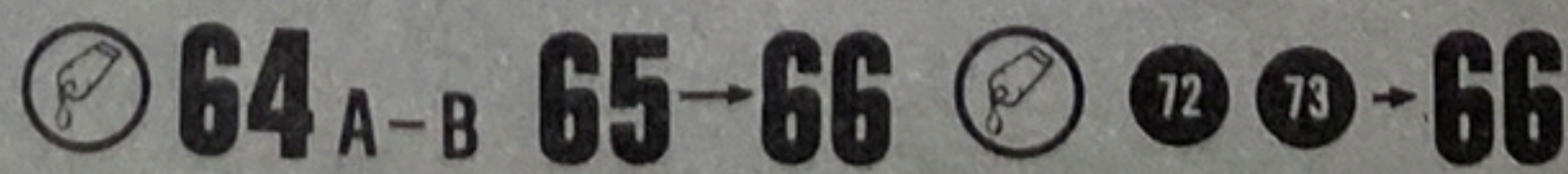
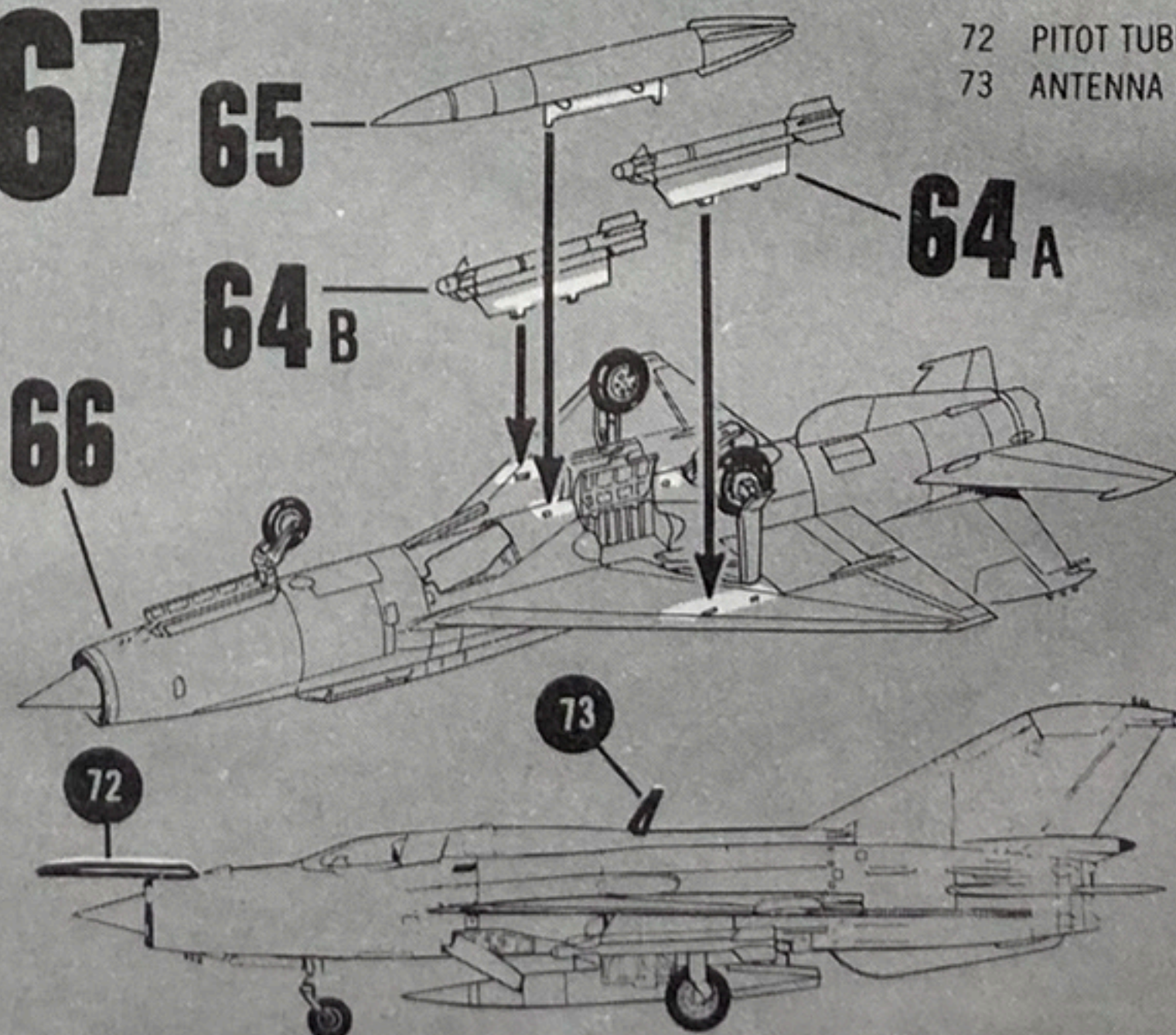

- 72 PITOT TUBE
- 73 ANTENNA

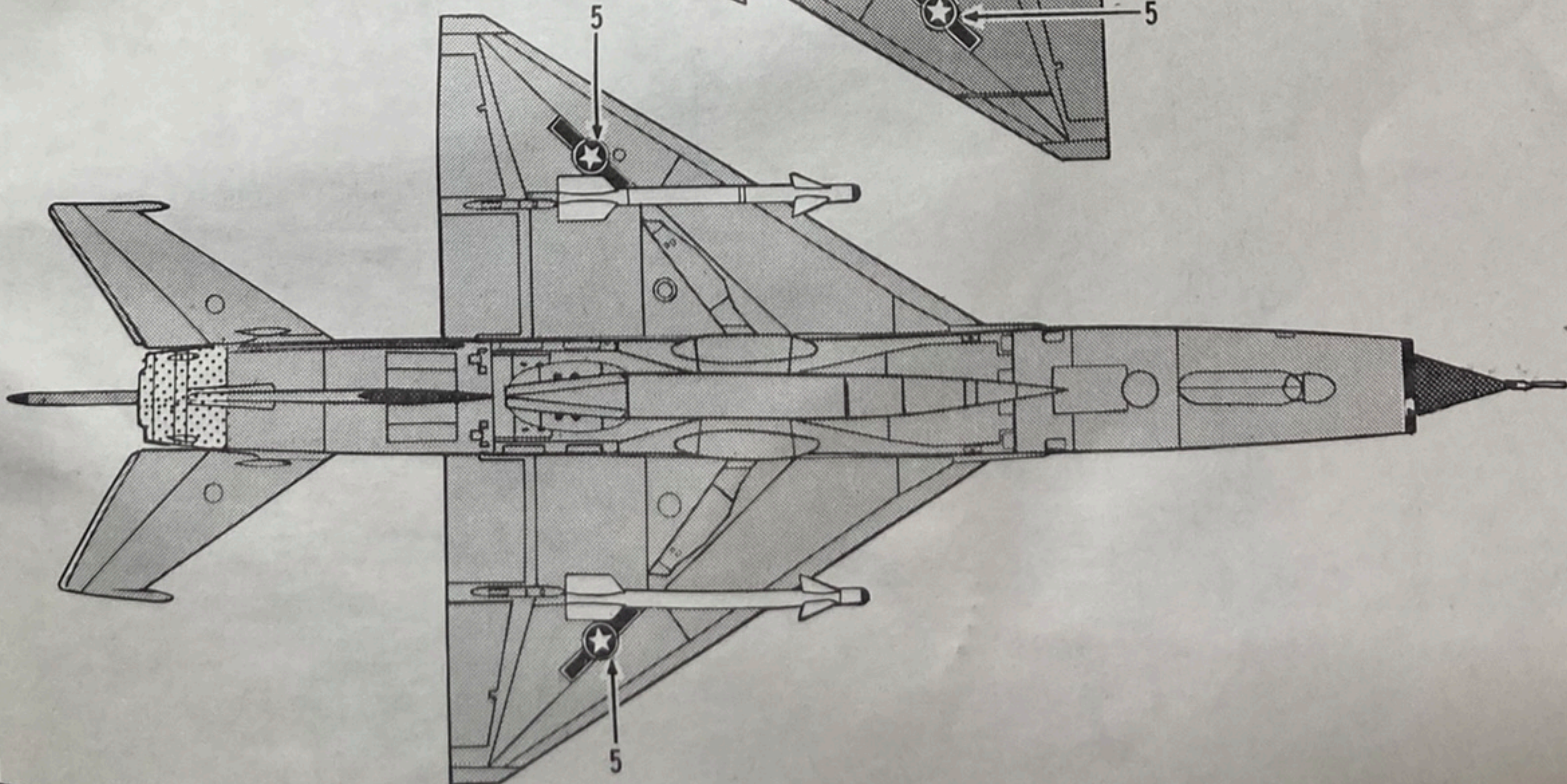
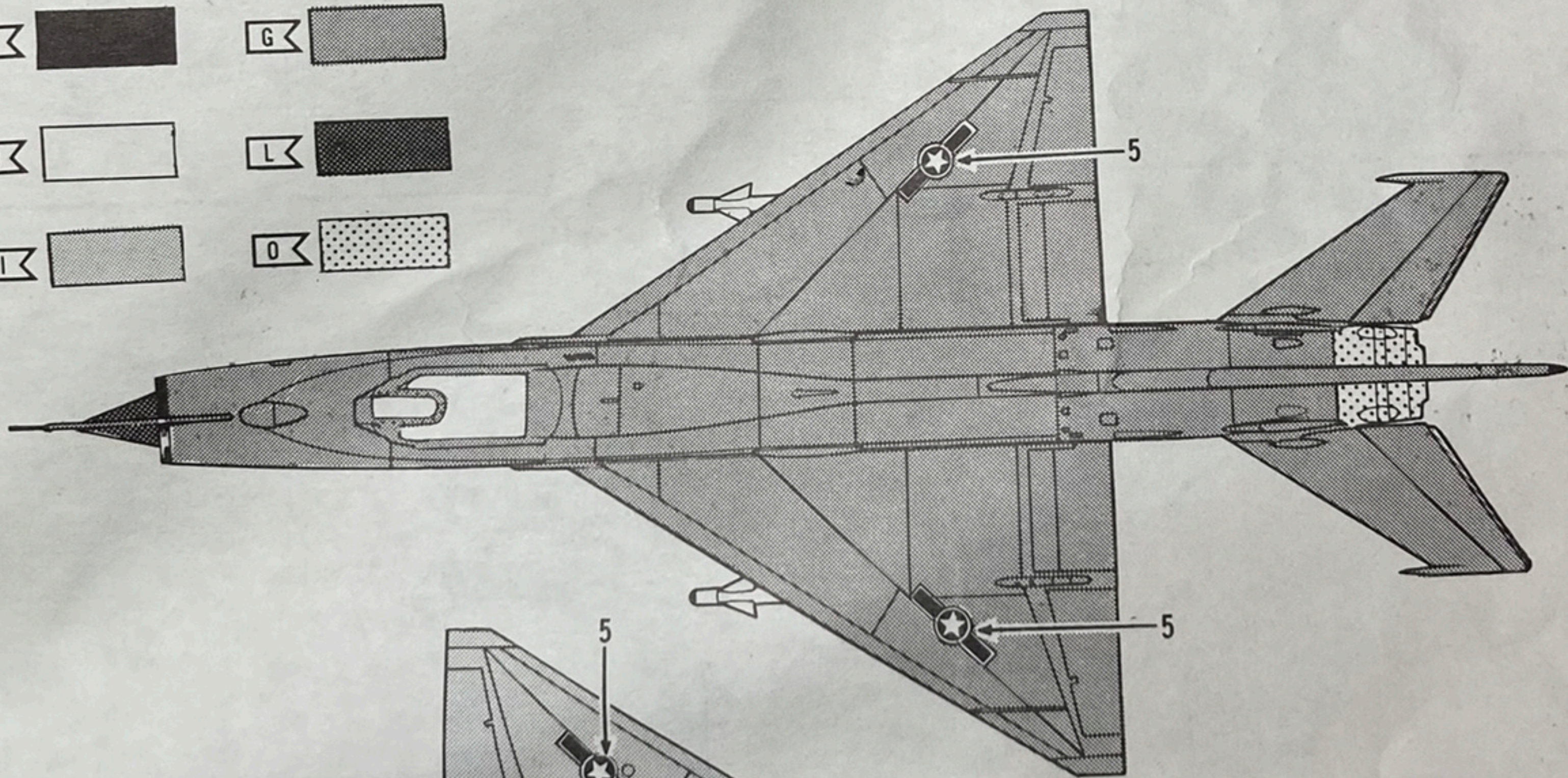
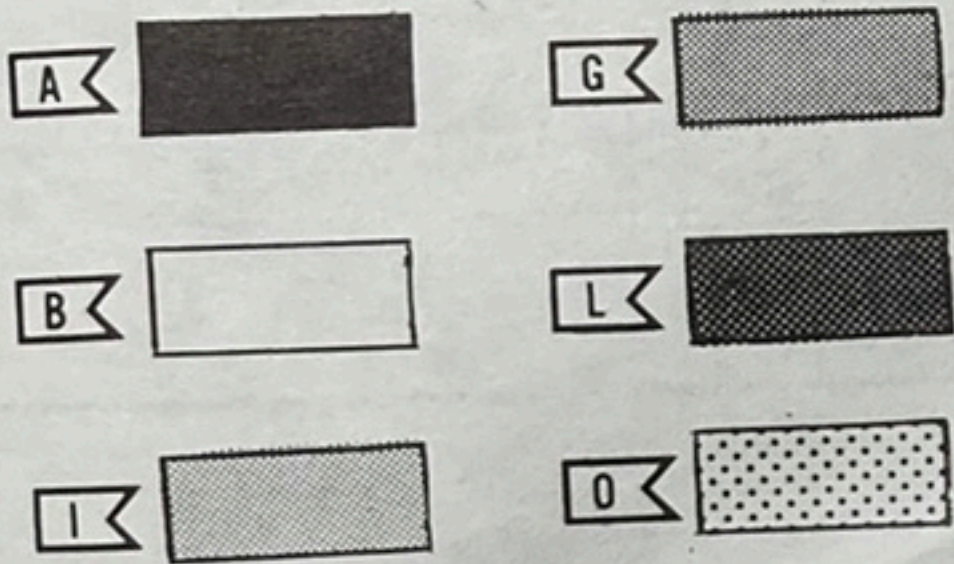
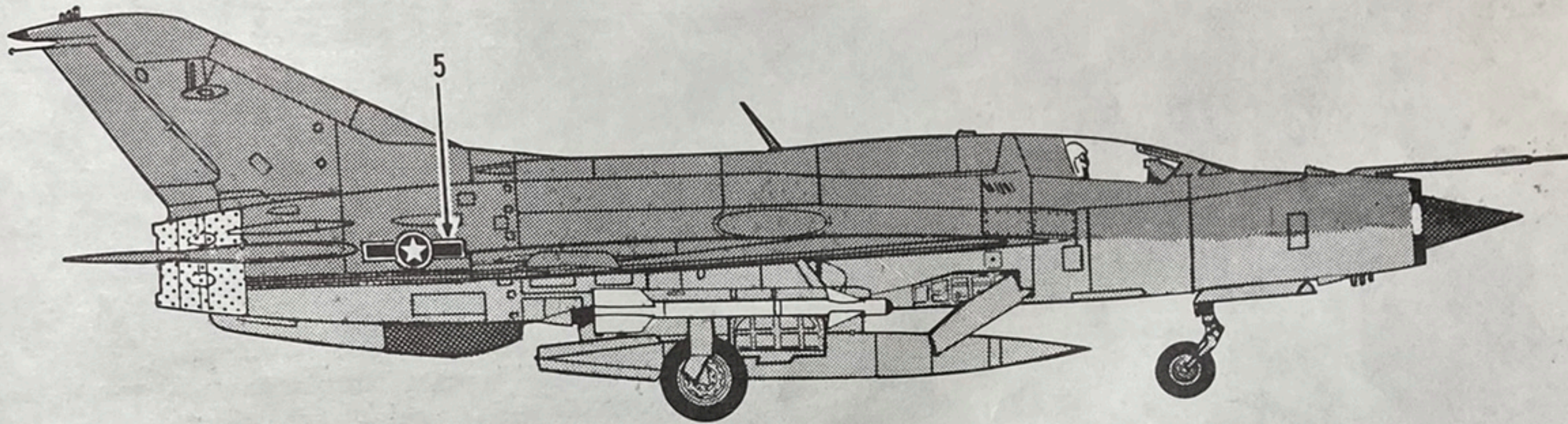
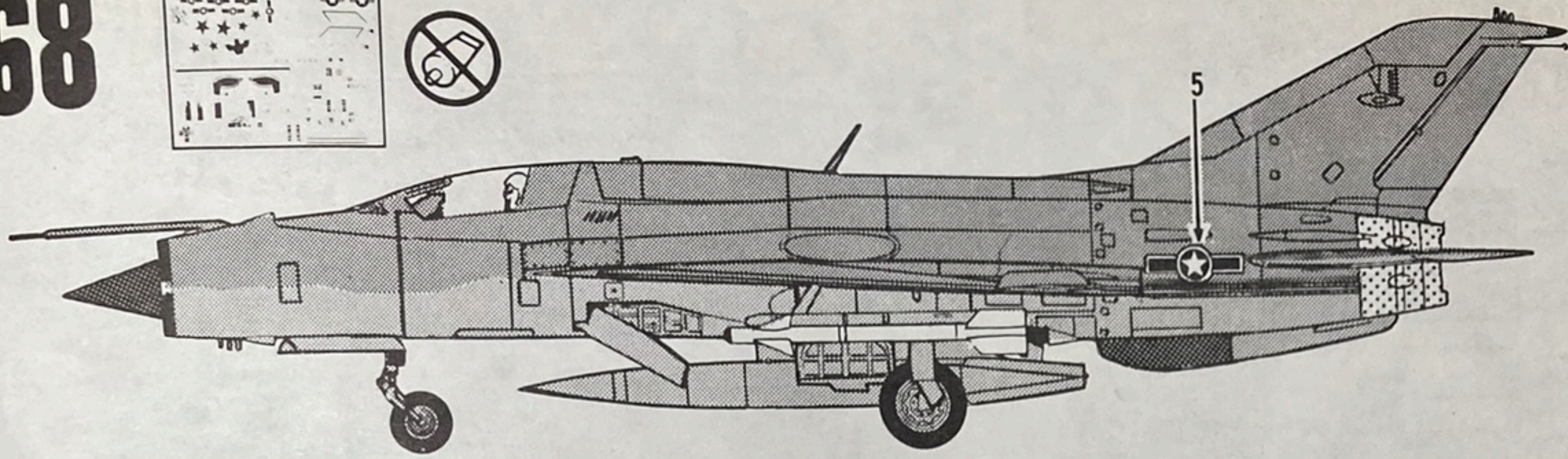

68

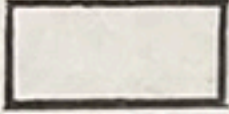

69

- A 
- B 
- F 
- M 
- O 