

# PANTHER Ausf.G Late Production

## w/IR & Air Defense Armour

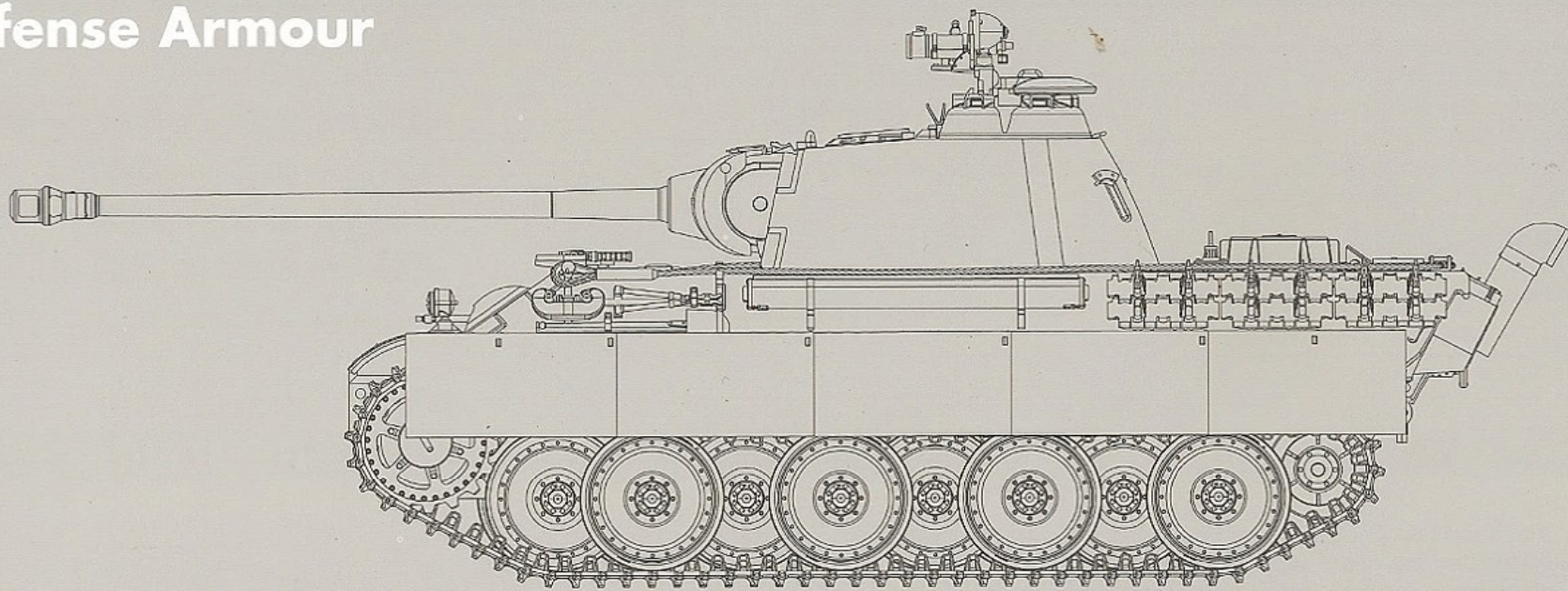

When the German Panzer IV met the Russian T-34 in June 1941, they were humiliated by being outclassed by the T-34, so a group of weapons specialists were sent to the Russian front to analyze the T-34's design. With these results, Daimler-Benz (DB) and Maschinenfabrik Augsburg (MAN) were both tasked with providing designs for a 30-ton medium tank by April 1942. The MAN design was accepted in May 1942, mainly because it was able to use an existing turret designed by Rheinmetall-Borsig, saving valuable time needed to design a new turret required with the DB design.

The Panther design adapted many of its successful design characteristics from the T-34. These were mainly the sloped armor, and the wide tracks (to make maneuvering in snow conditions of the Eastern front easier). In September 1942 the first prototype was tested and immediately pressed into service. Despite delays in production due to the lack of manufacturing equipment of the hull, the first rushed deliveries to the German Army were completed in December, but the tank was plagued by technical problems. Despite these early issues, the tank was very successful, and due to its high demand on the Eastern Front, the original production of 250 tanks per month at the MAN plant, was increased to 600 tanks per month in January in 1943, which resulted in production also being allocated to the Daimler-Benz, Maschinenfabrik Niedersachsen-Hannover (MNH), and the Henschel & Sohn plants to meet production quotas. Due to Allied bombing throughout the war, the required production amount was never met and only 6,000 in total were built.

The 700hp Maybach V-12 petrol engine with its seven-speed AK 7-200 synchromesh gearbox designed by ZF, was fitted with a governor in late 1943 to minimize engine failures by limiting the engine revolutions to 2500 rpm and reducing its power to 600 hp. This reduced the Panthers top speed from 55 km/h to 46 km/h. The Panther had a five-man crew: the driver, radio operator, gunner, loader, and commander.

The Panther was armed with a semi-automatic 75mm Rheinmetall-Borsig KwK 42 main gun, and could carry 79 rounds of three different types of ammunition: Armour-Piercing Capped Ballistic Capped, (APCBC), High-Explosive (HE) and Armour-Piercing Composite Rigid (APCR). The 75mm cannon on the Panther was one of the most powerful cannons of WWII, and had even greater success at piercing enemy armour than the Tiger I's 88mm cannon. The Panther was also equipped with two 7.92mm Maschinengewehr 34 (MG-34) for close quarter fighting; one was mounted coaxially with the main cannon and the second was mounted in the front sloping armour and operated by the radio operator. In later production upgrades, a mount was attached to the commander's cupola so a third MG-34 could be mounted for anti-aircraft purposes.

The frontal armor of the Panther consisted of 80mm homogeneous steel plate sloped back at 55 degrees from the vertical, interlocked & welded for strength. This made the Panther's frontal armor less penetrable to Allied and Soviet tanks. The front of the turret was covered by a 100mm cast mantlet in the shape of a semi-circle, with a curved shape meant to deflect incoming shells. To keep weight down, sacrifice was made to its side armor, which was on average 40mm to 50mm thick, leaving the Panther vulnerable to attacks from the sides by Allied and Soviet tank and anti-tank guns.



# READ BEFORE ASSEMBLY

## CAUTION

- Read carefully and fully understand the instructions before commencing assembly. A supervising adult should also read the instructions if a child assembles the model.
- When assembling this kit, tools including knives used. Extra care should be taken to avoid personal injury.
- Keep out of reach of small children. Children must not be allowed to suck any part, or pull vinyl bag over their heads.



Optional



Instant Glue for Metal



Remove

## PAINTS REQUIRED

Color info and profiles by Mig Jimenez

A.MIG-0033 Rubber & Tires	A.MIG-0035 Dark Tracks	A.MIG-0037 New Wood	A.MIG-0070 Medium Brown
A.MIG-0045 Gun Metal	A.MIG-0003 Resed grun	A.MIG-0011 Dunkelgelb Aus'44 DGI	A.MIG-0086 Crystal Periscope Green
A.MIG-0095 Crystal Smoke	A.MIG-0014 Rotbraun	A.MIG-0008 Dunkel Grau	A.MIG-0015 Schokabraun
A.MIG-0016 Gelbbraun	A.MIG-0012 Dunkelgelb AUS'44 DG III	A.MIG-0004 Resedagrün	

## APPLYING DECALS

1. Clean the model surface with a wet cloth.
2. Cut out each decal design from sheet, and dip it in tepid water for 15~20 sec.
3. Hold the backing sheet edge and slide decal onto the model.
4. Move decal into position by wetting decal with finger.
5. Press decal gently down with a soft cloth until excess water and air bubbles are gone.

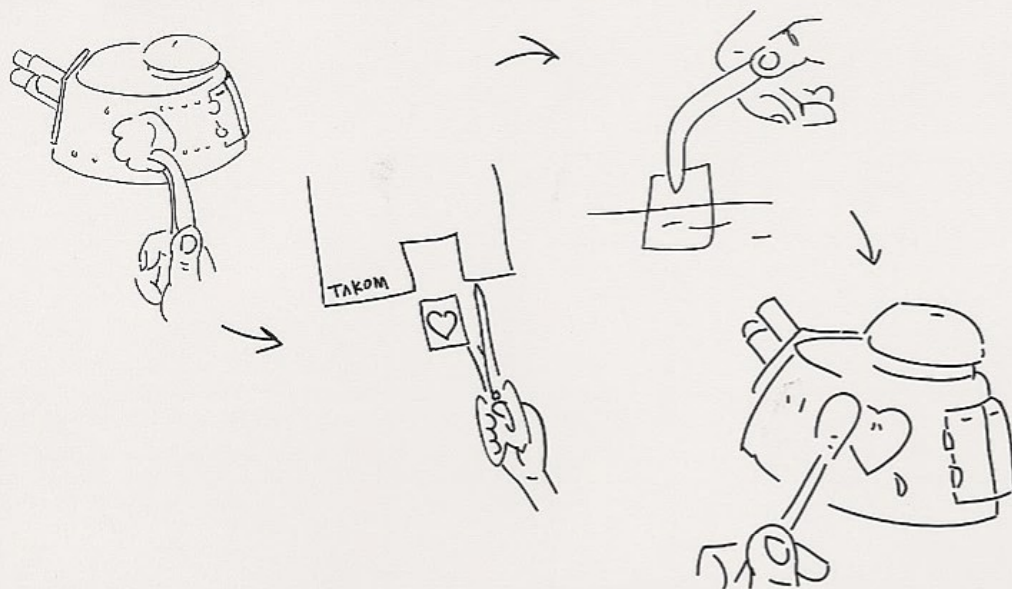

## REMOVING PE

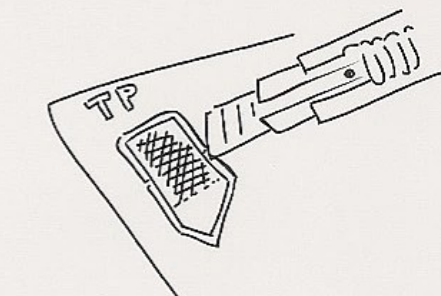

Be careful not to hurt when removing PE parts.

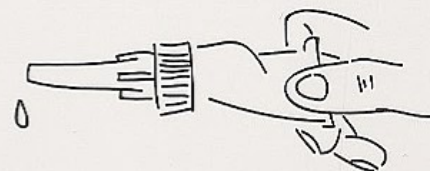

Secure using instant glue (not included).

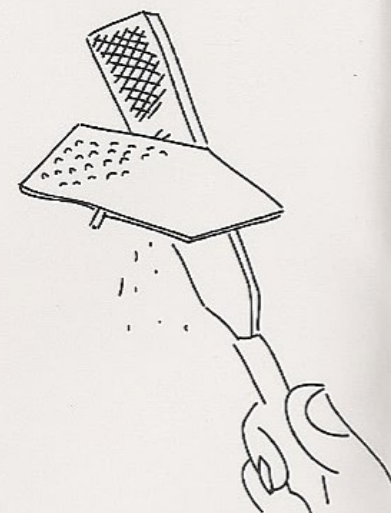

Finish using file.



# PARTS

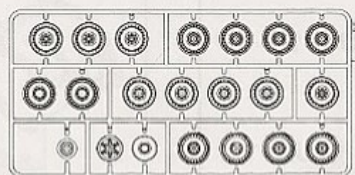
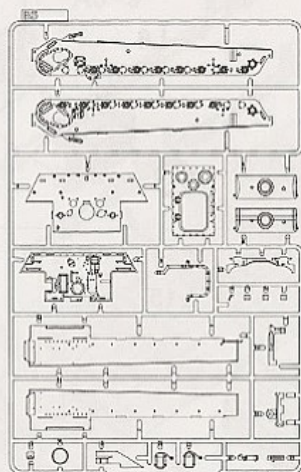
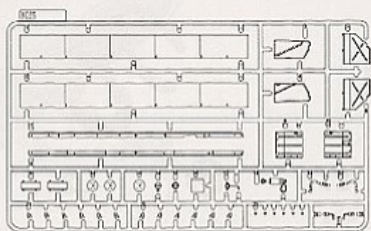
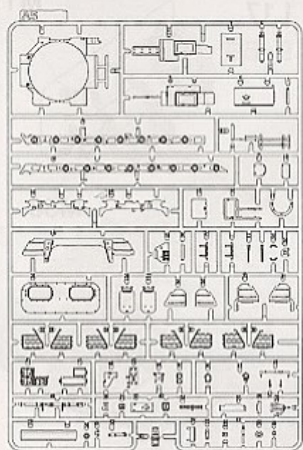

X2

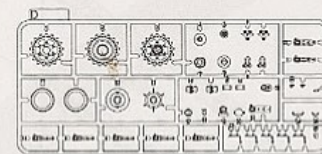

X2

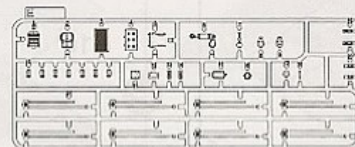
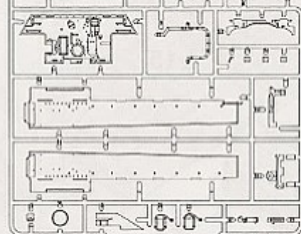
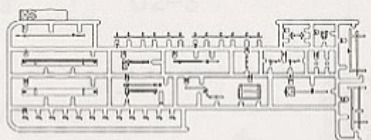
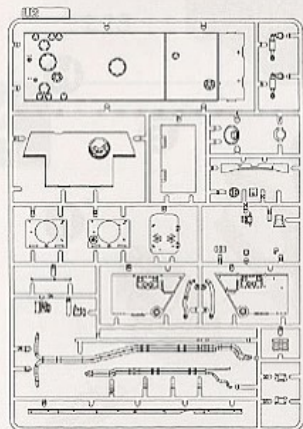
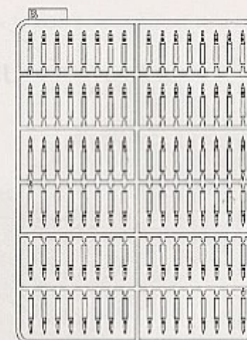

X2

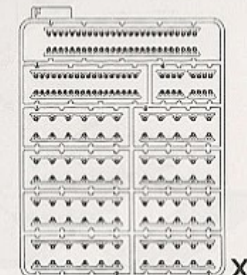
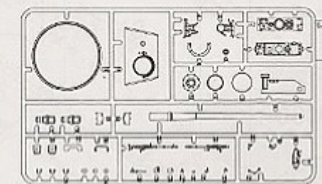

X2

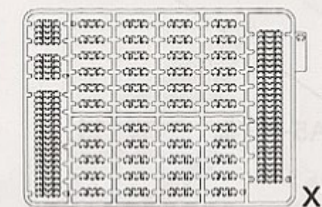
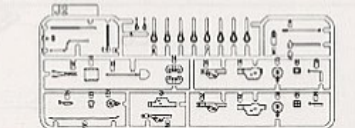
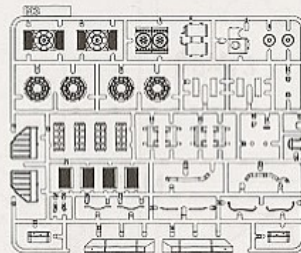
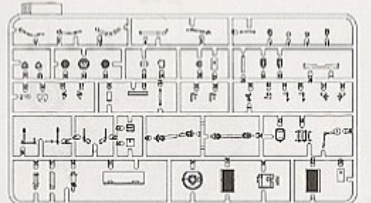
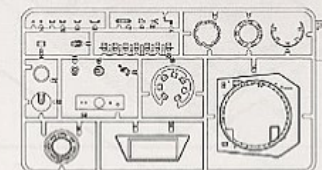
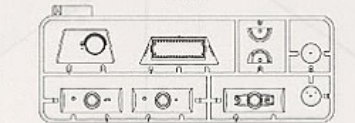
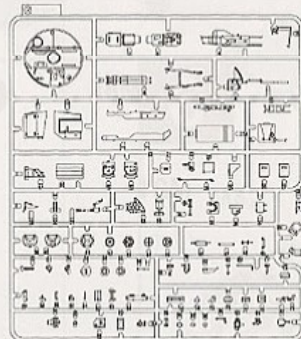
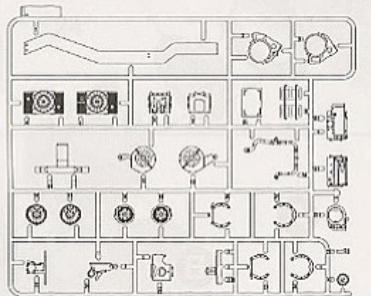

X2

Cable

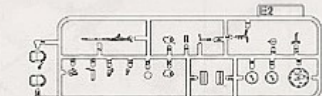
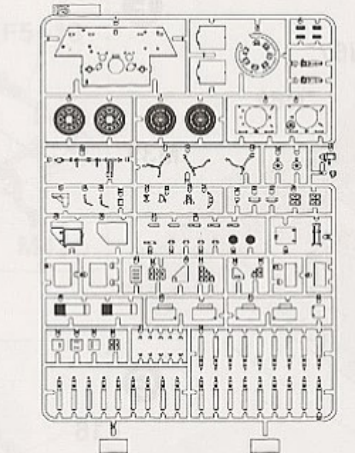
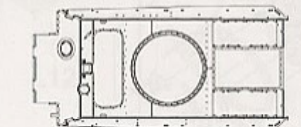
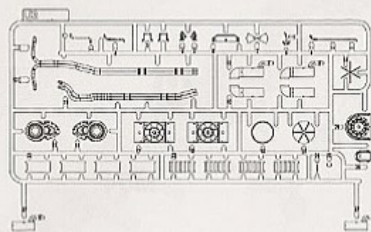

Z3



Turret

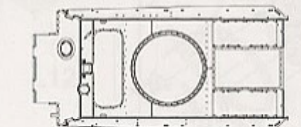
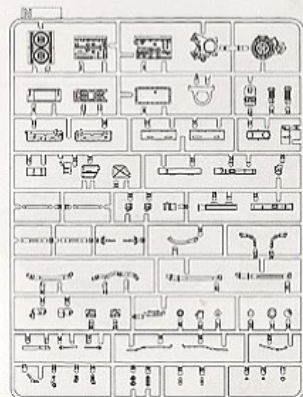

Z6



Z2



Z5



Z1



TP

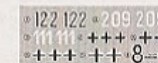

Decal

Upper Hull

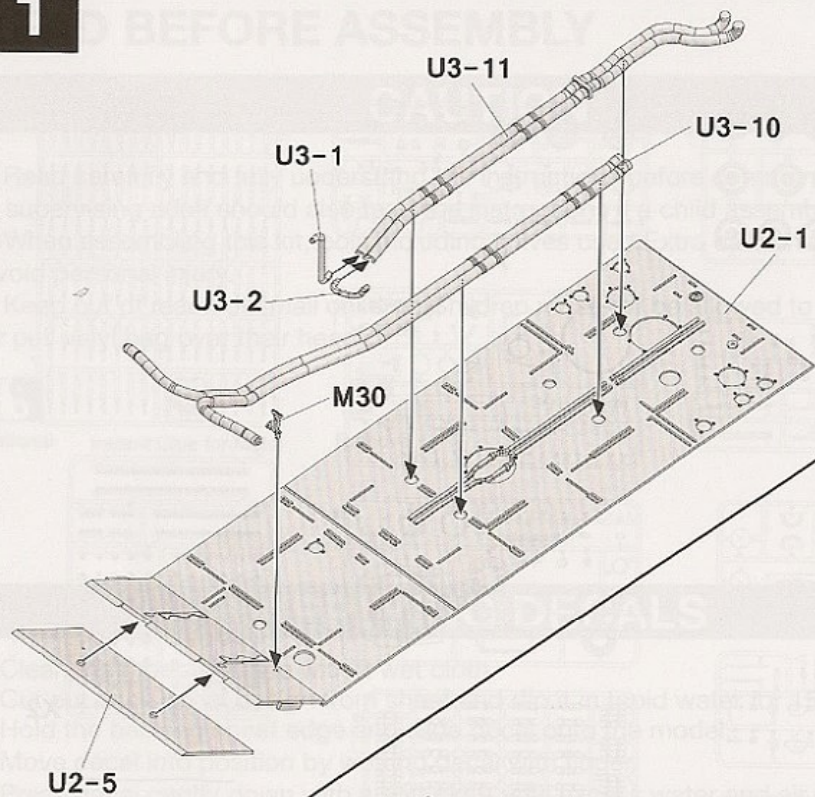
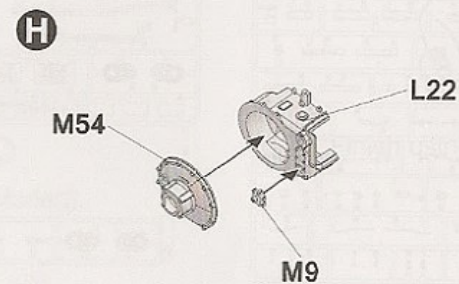
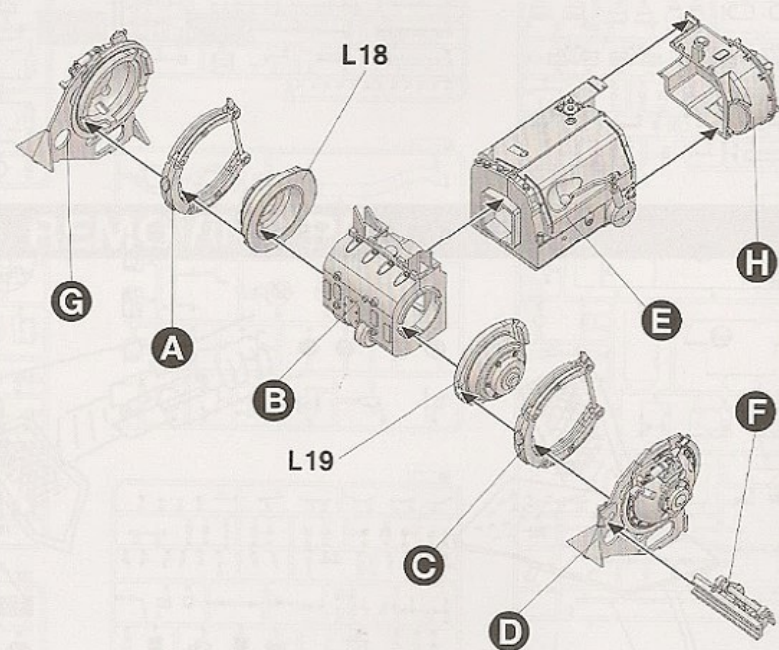
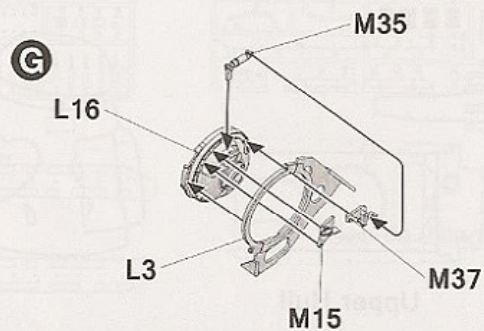
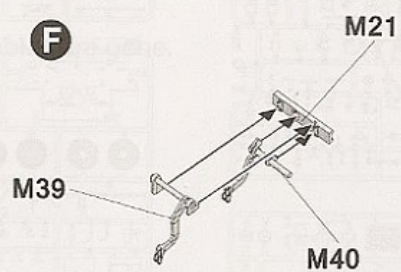
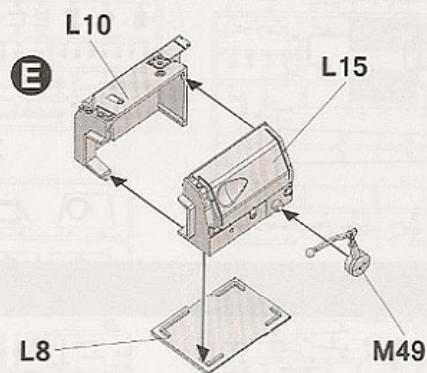
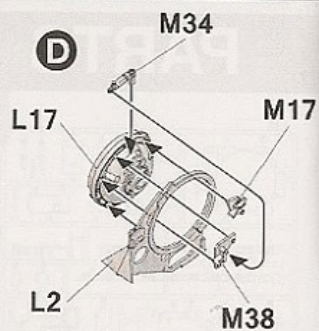
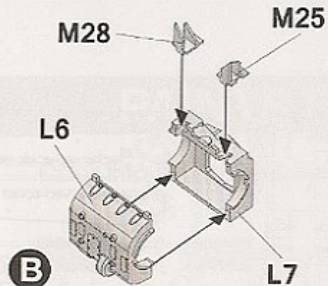
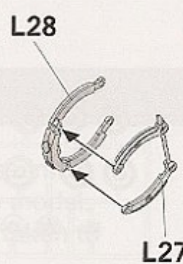
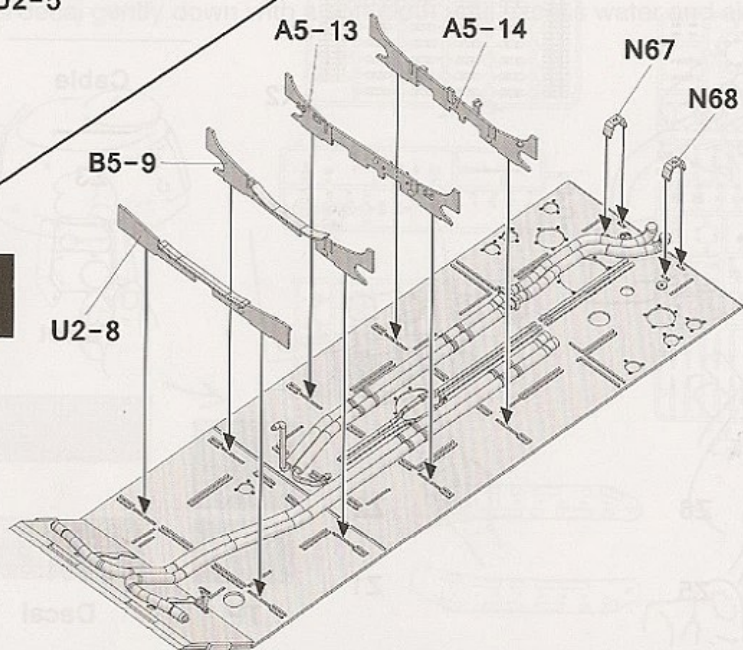

**1****2****3**



3

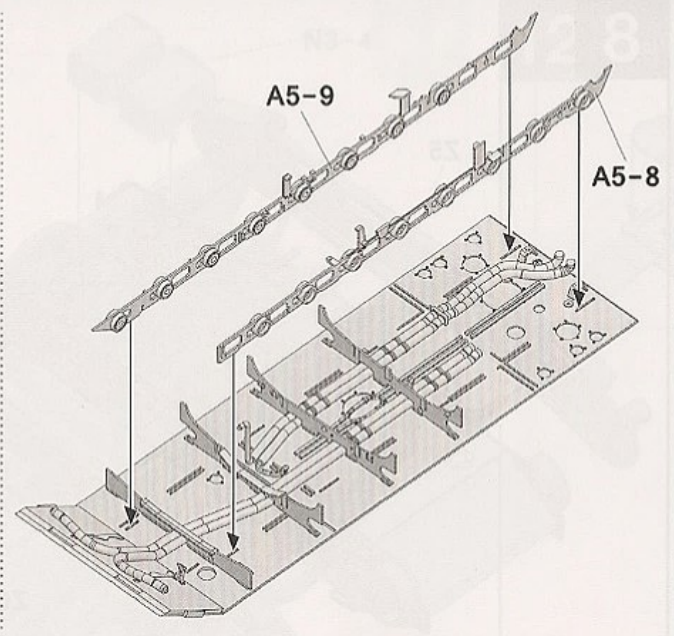
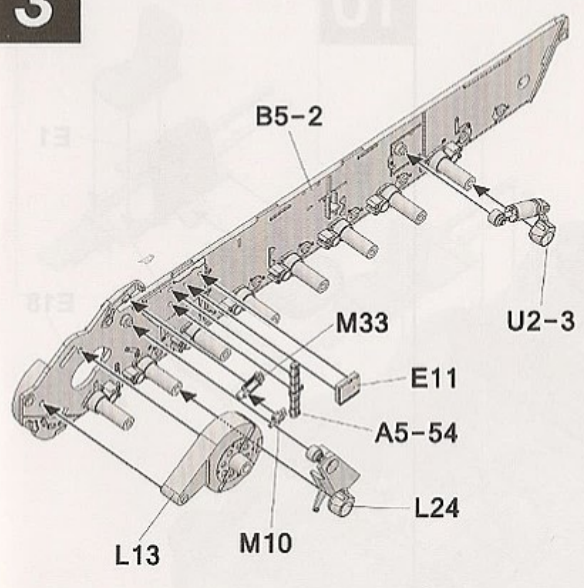

5

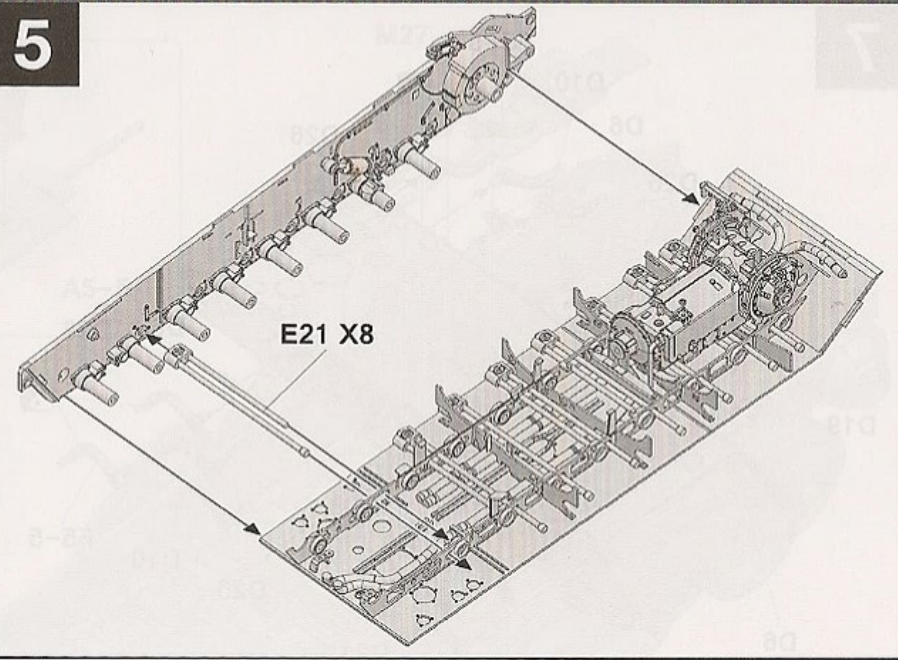

4

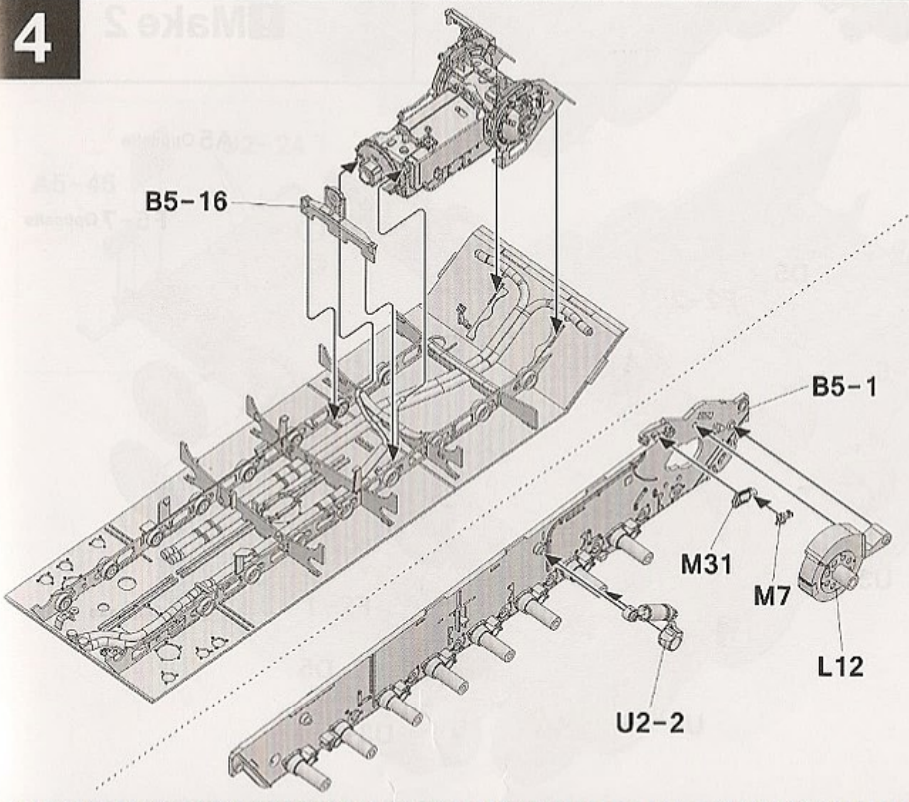

6

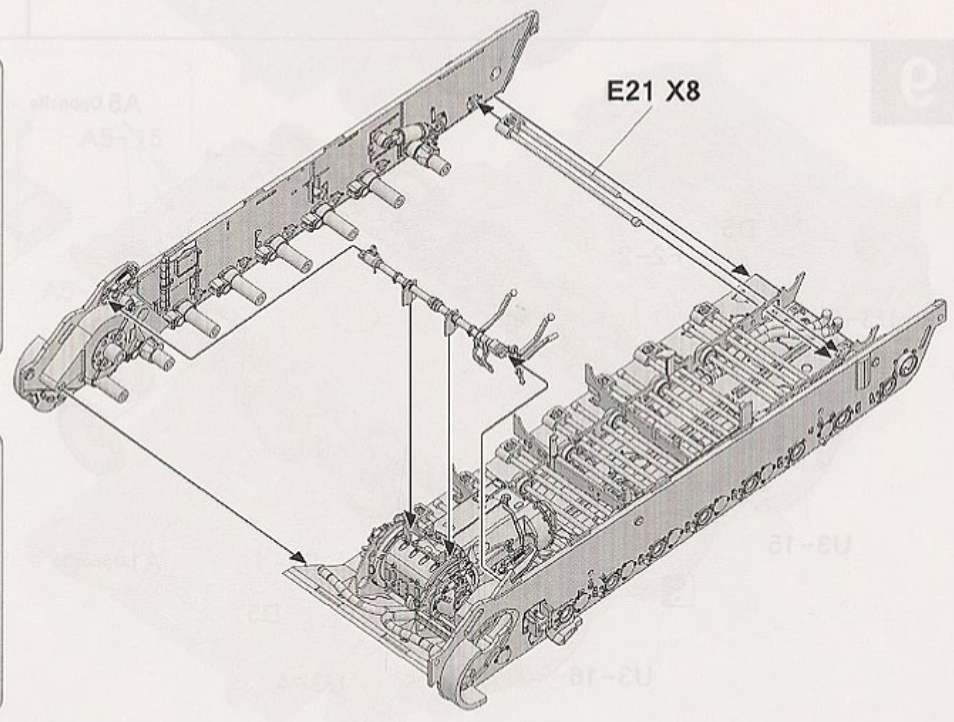
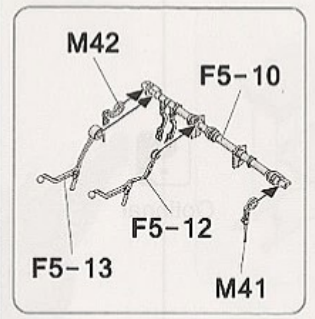



7

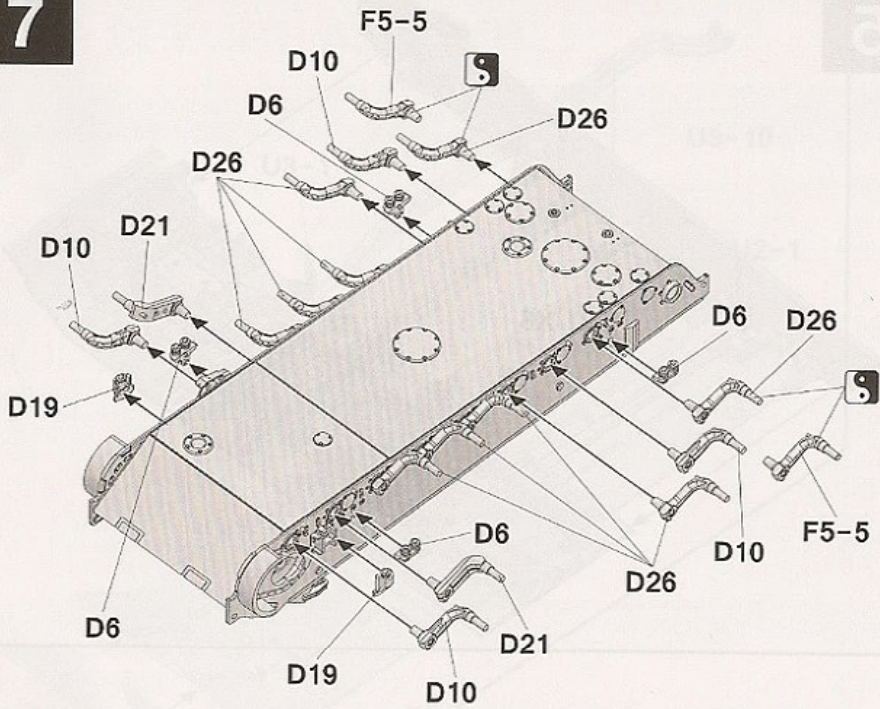

8

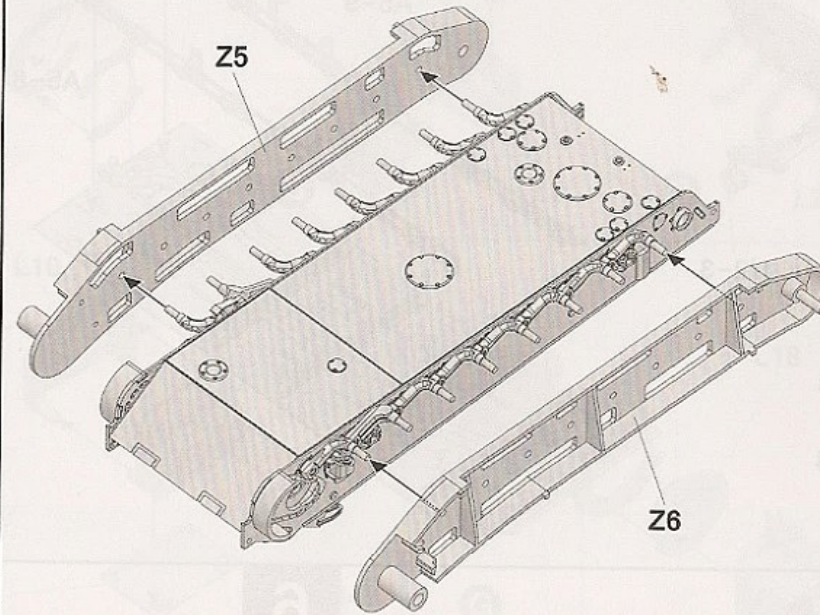

10

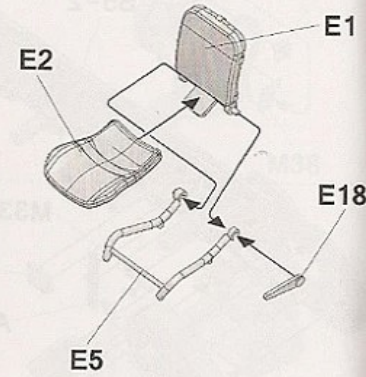

Make 2

9

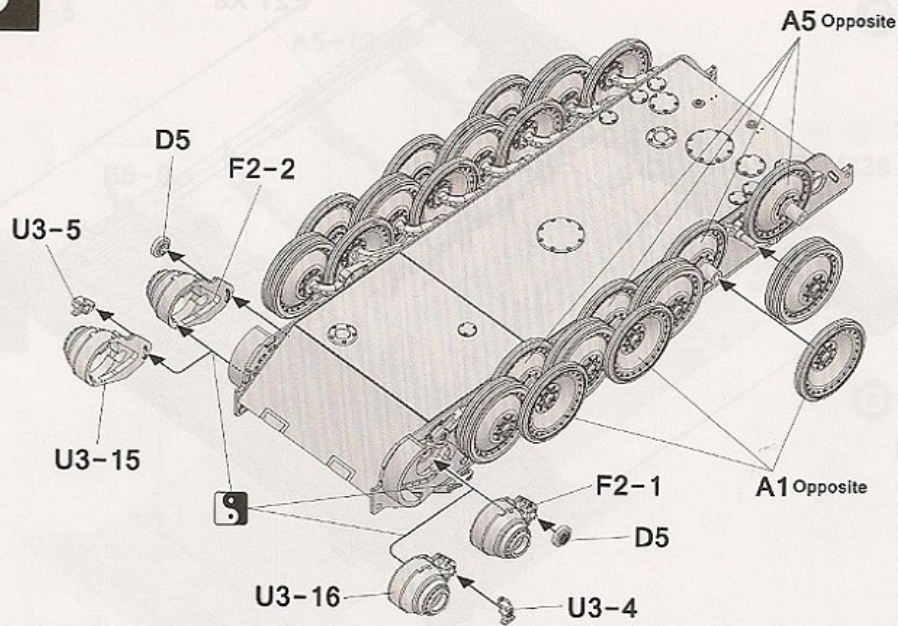

Optional

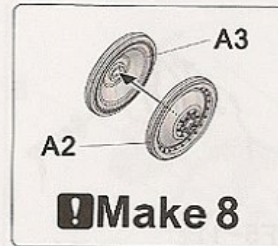

5

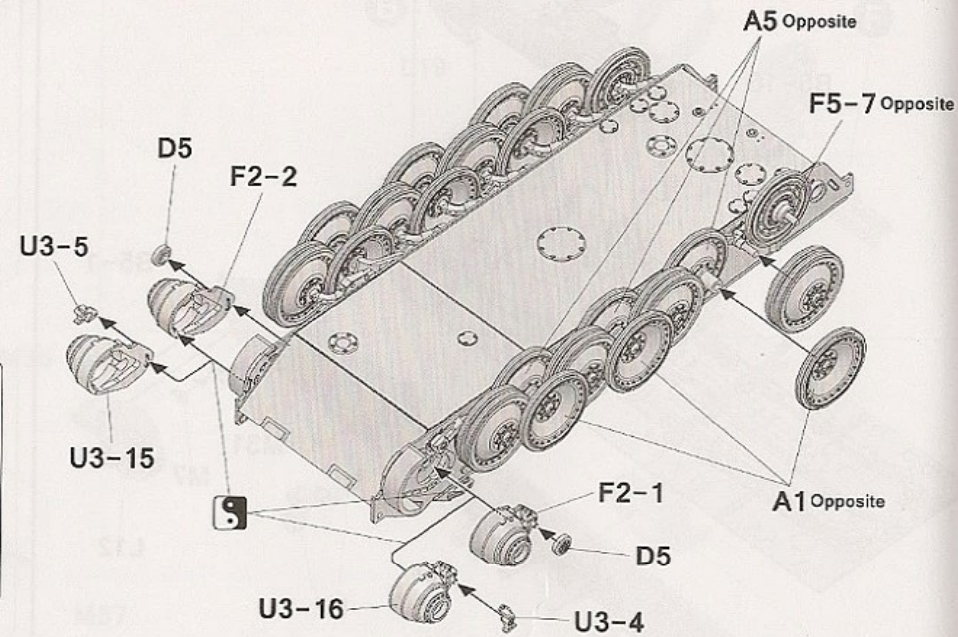



11

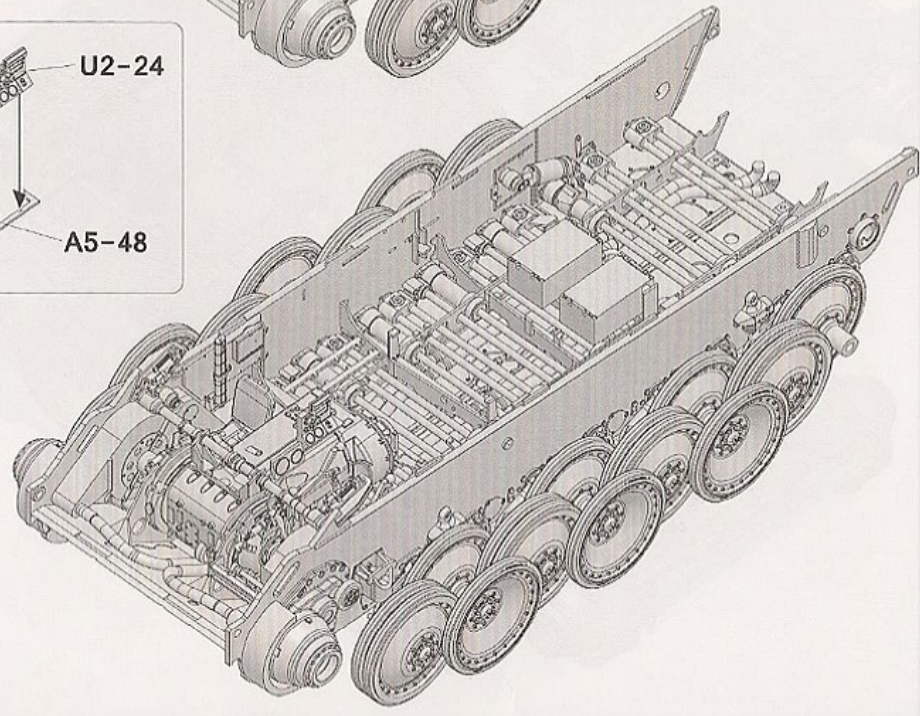
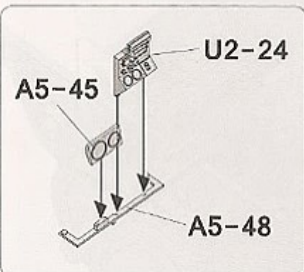
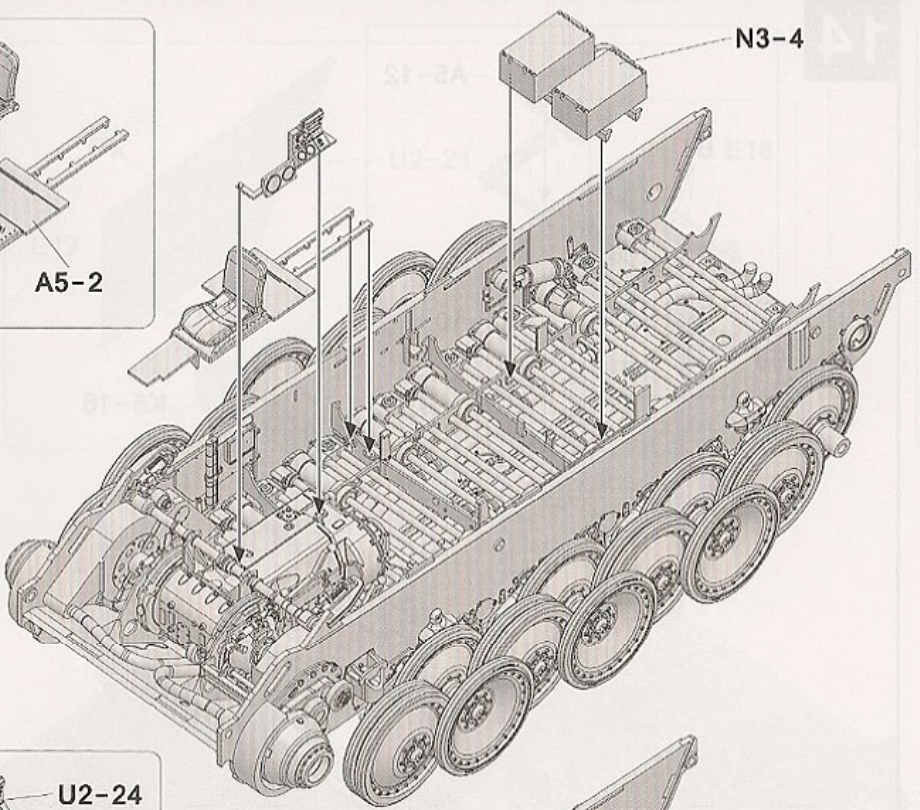
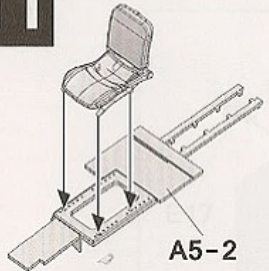

12

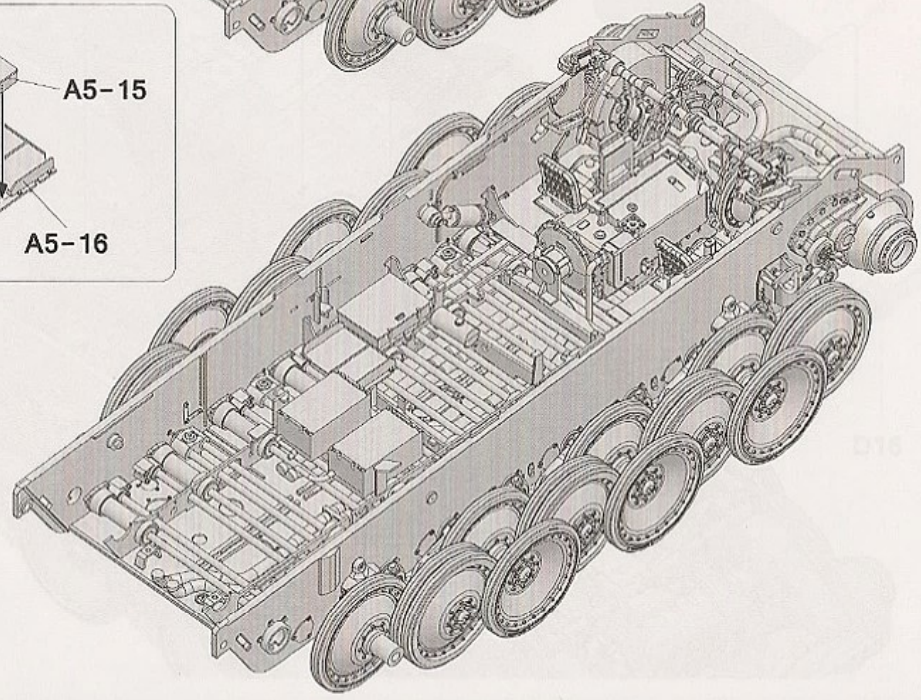
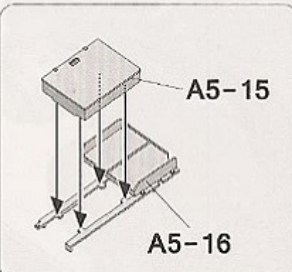
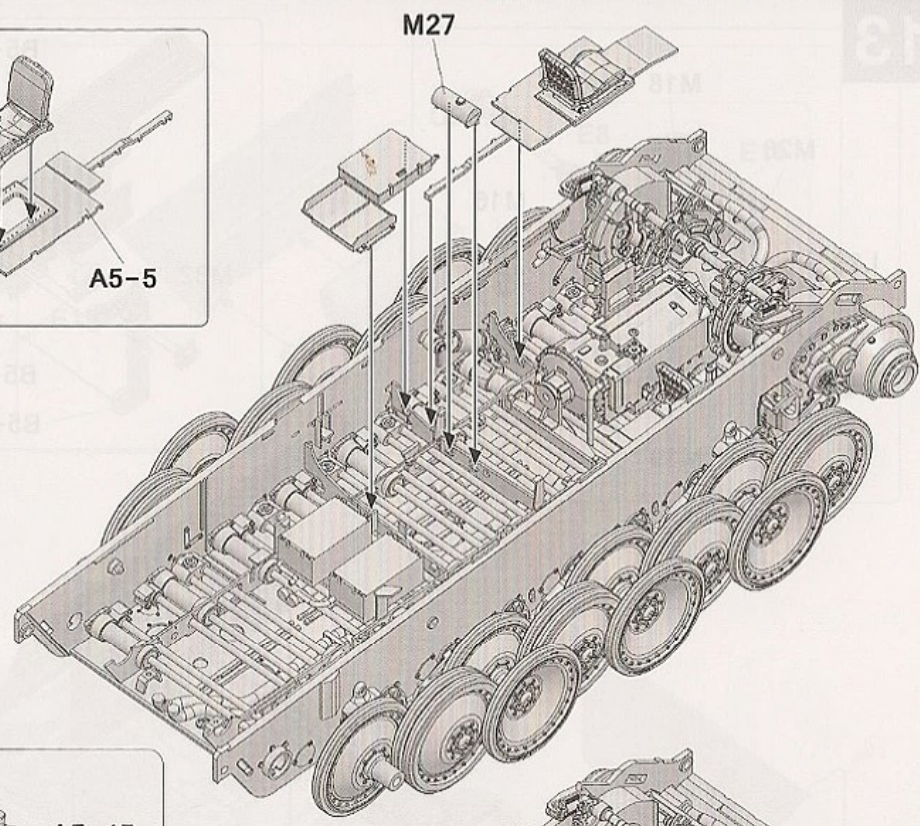
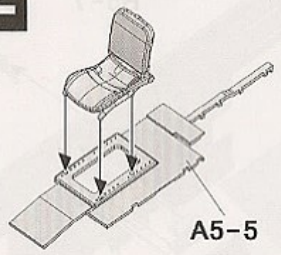



13

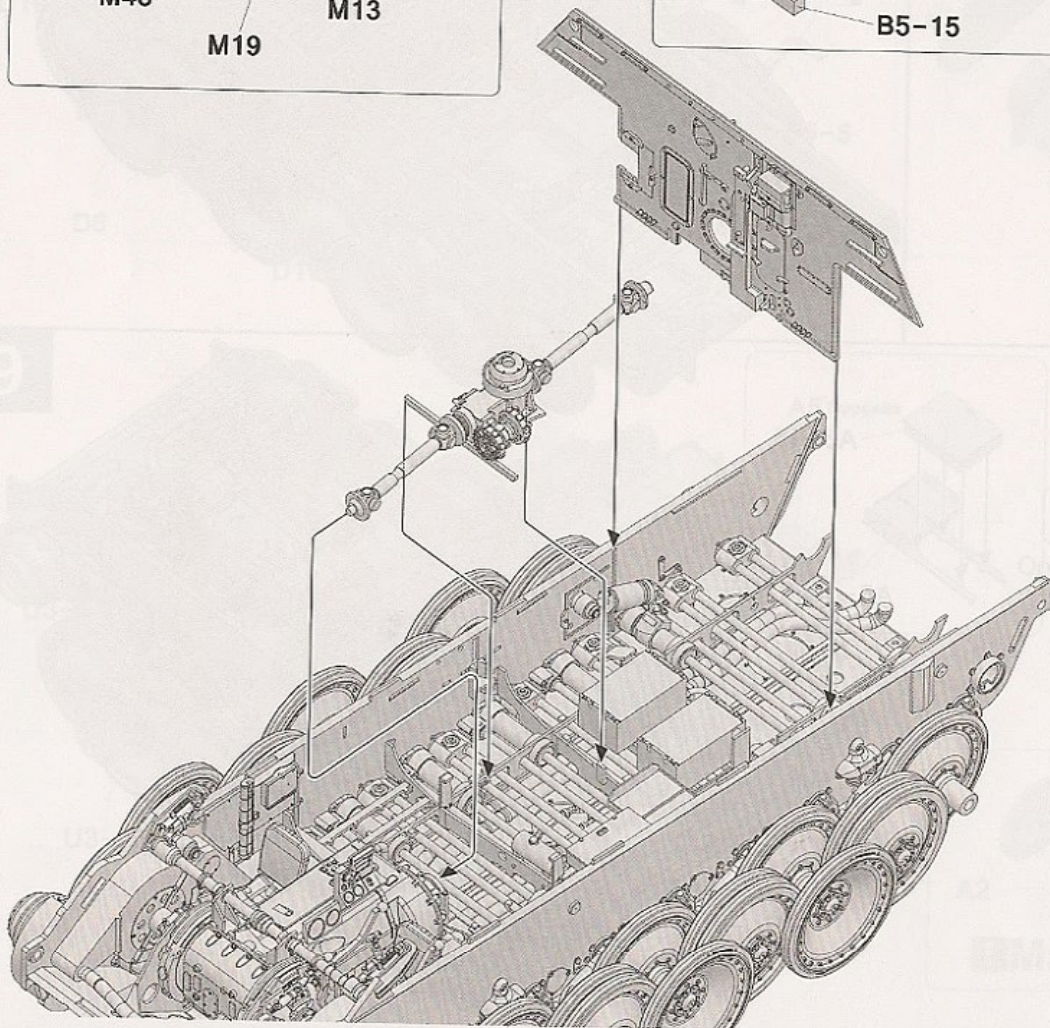
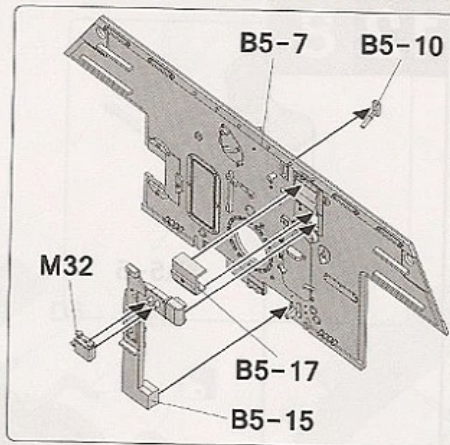
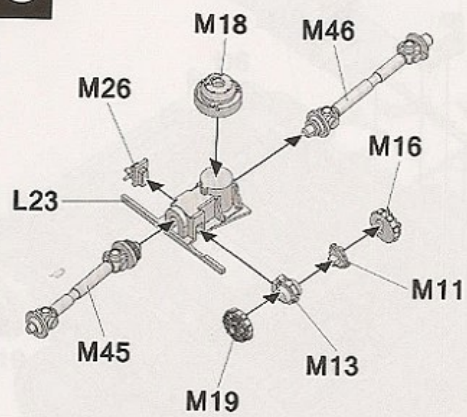

14

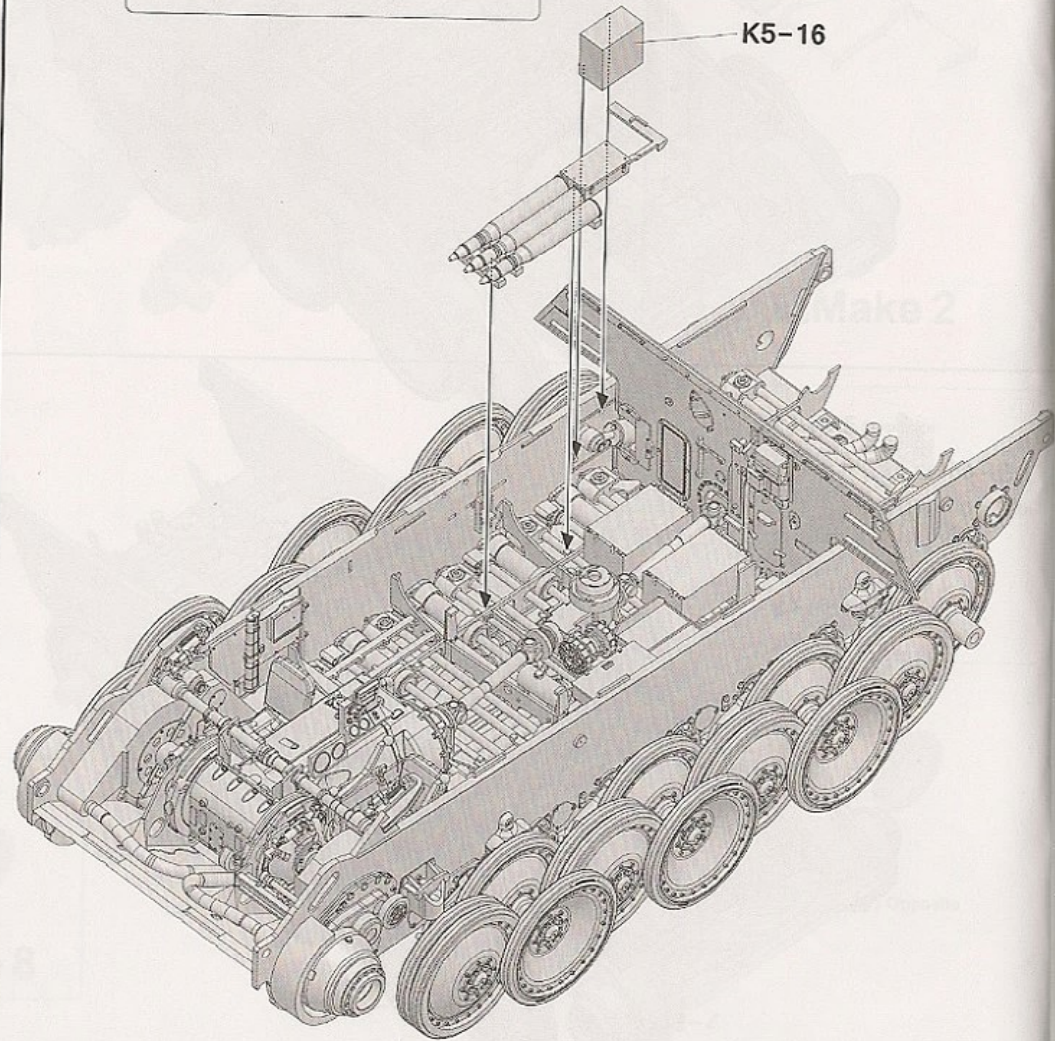
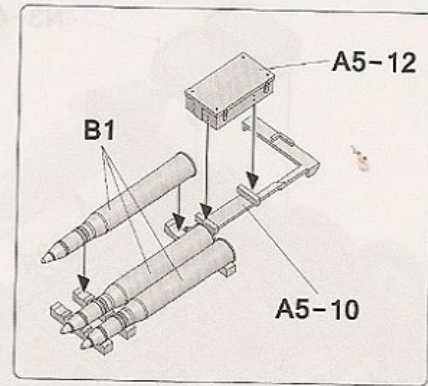



15

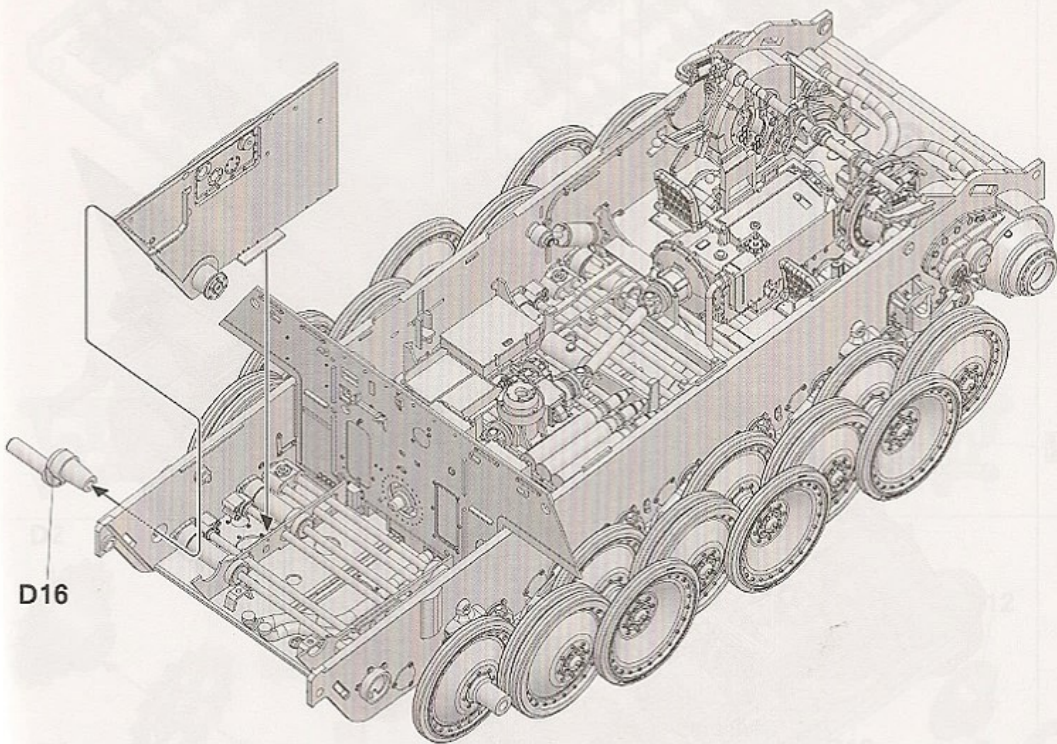
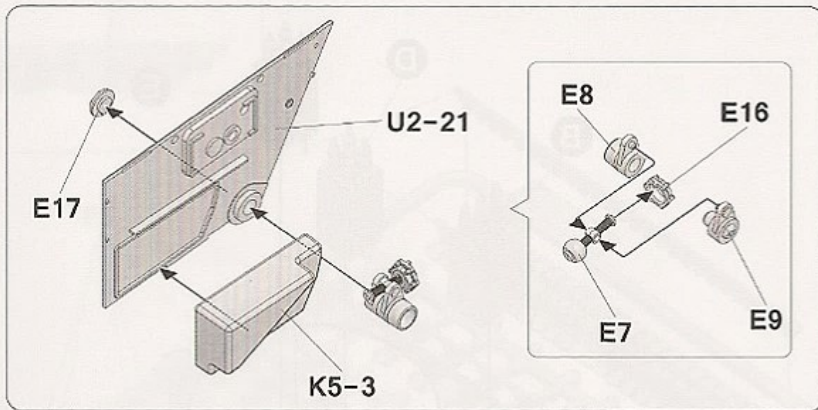

16

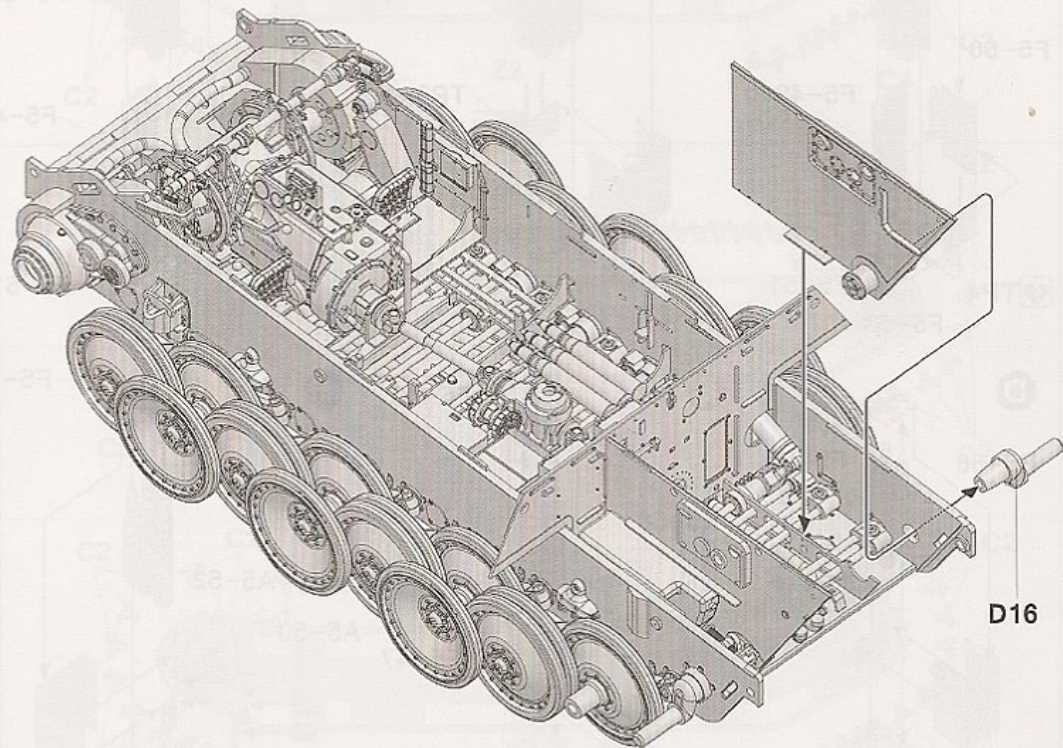
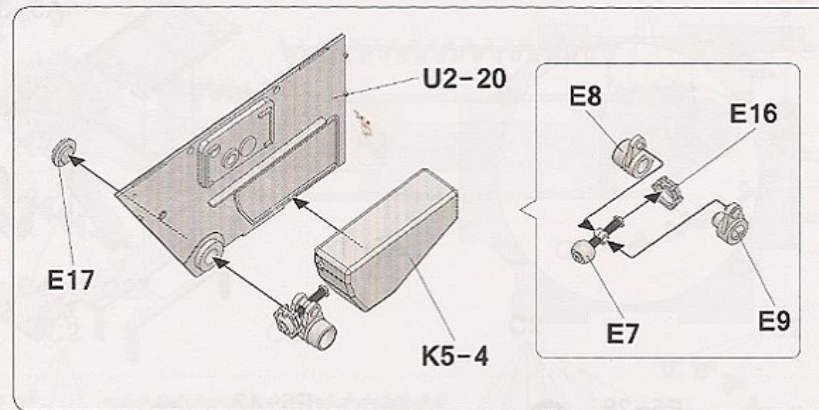



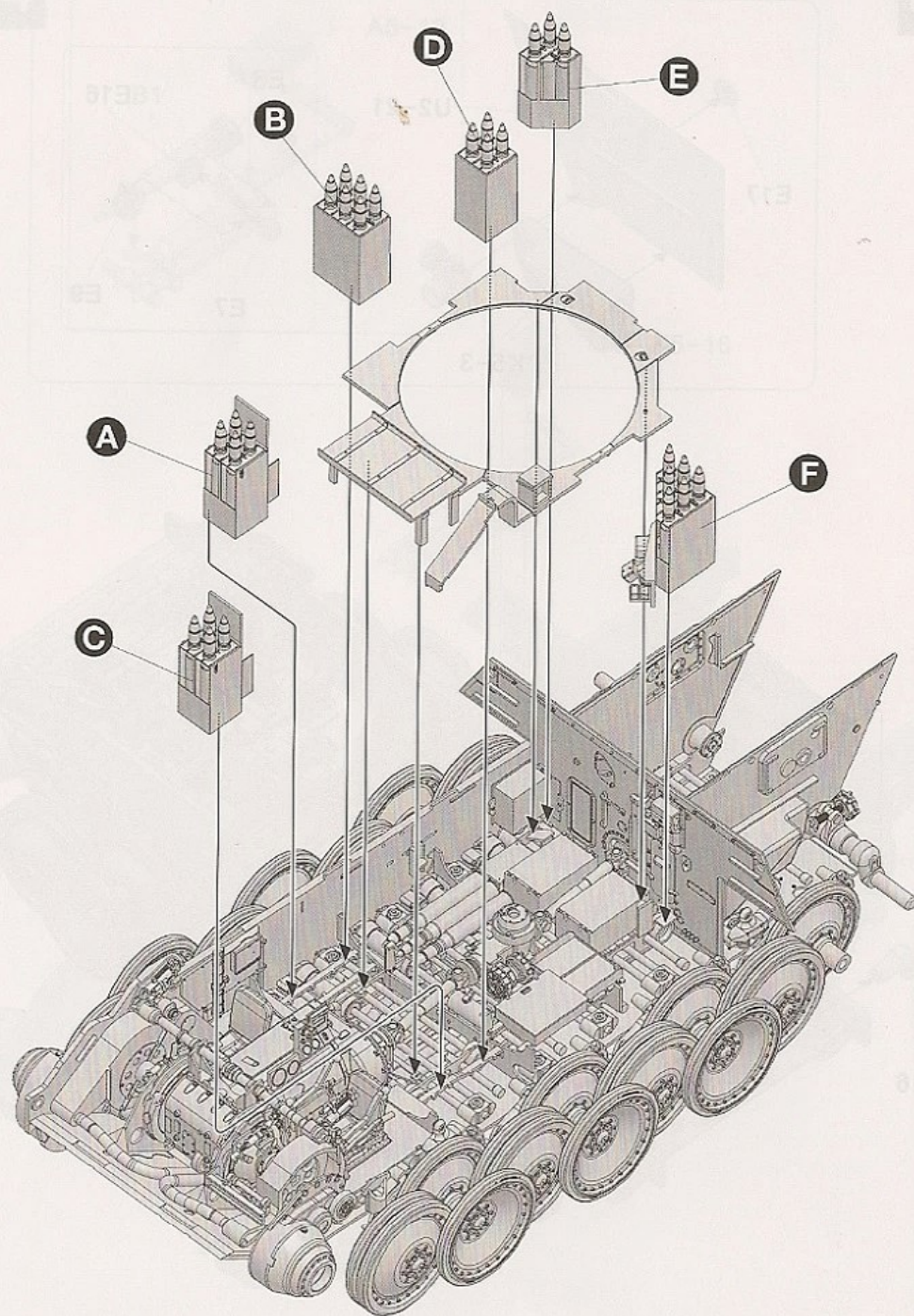
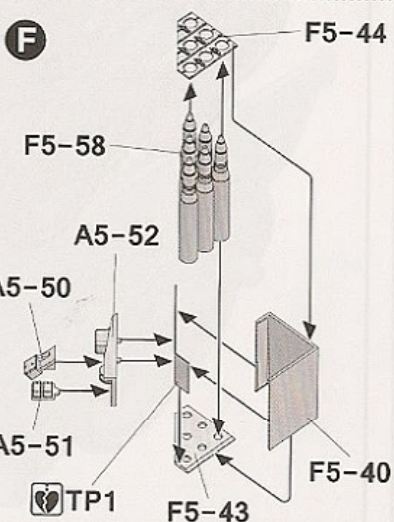
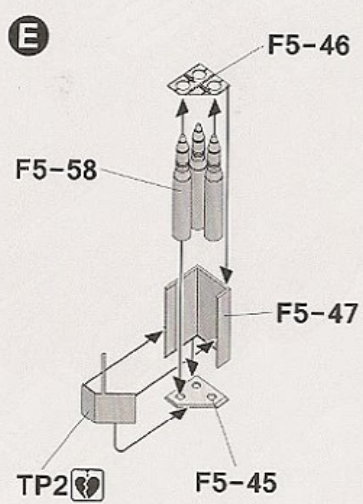
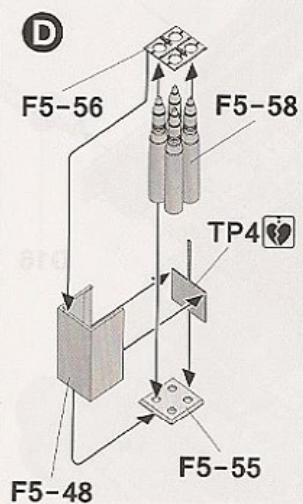
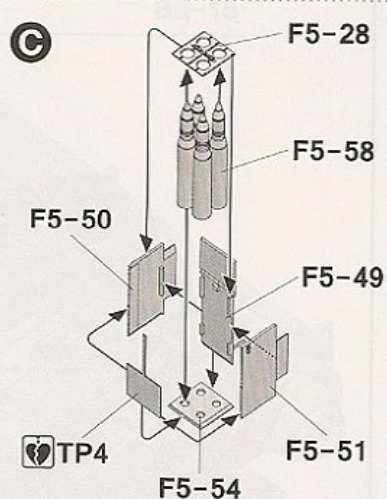
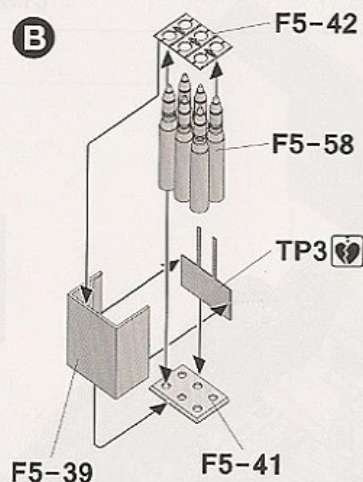
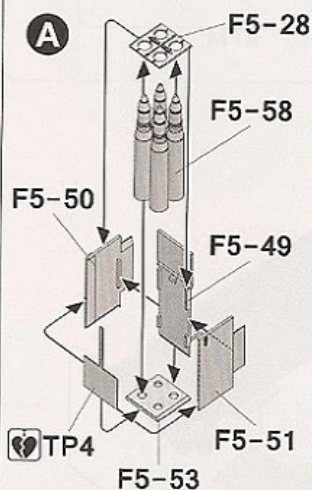
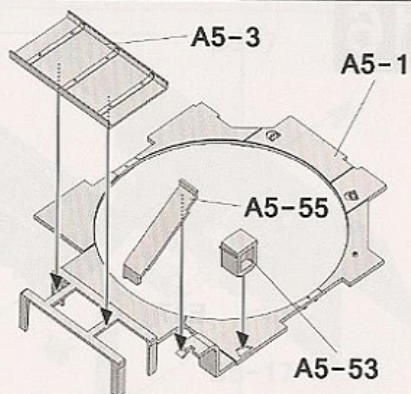
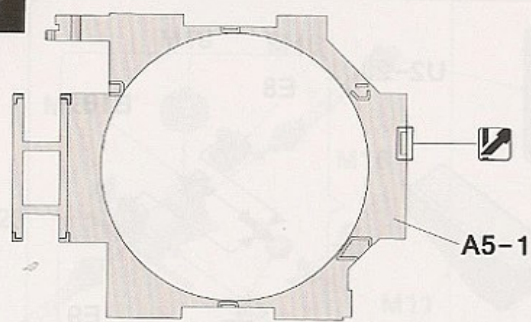



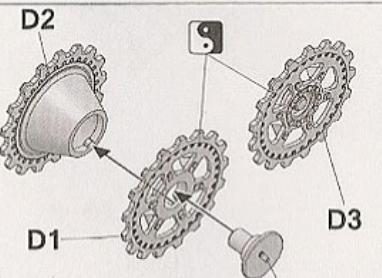
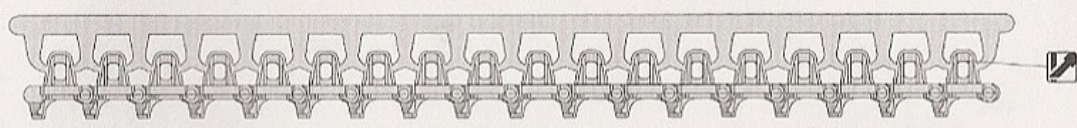
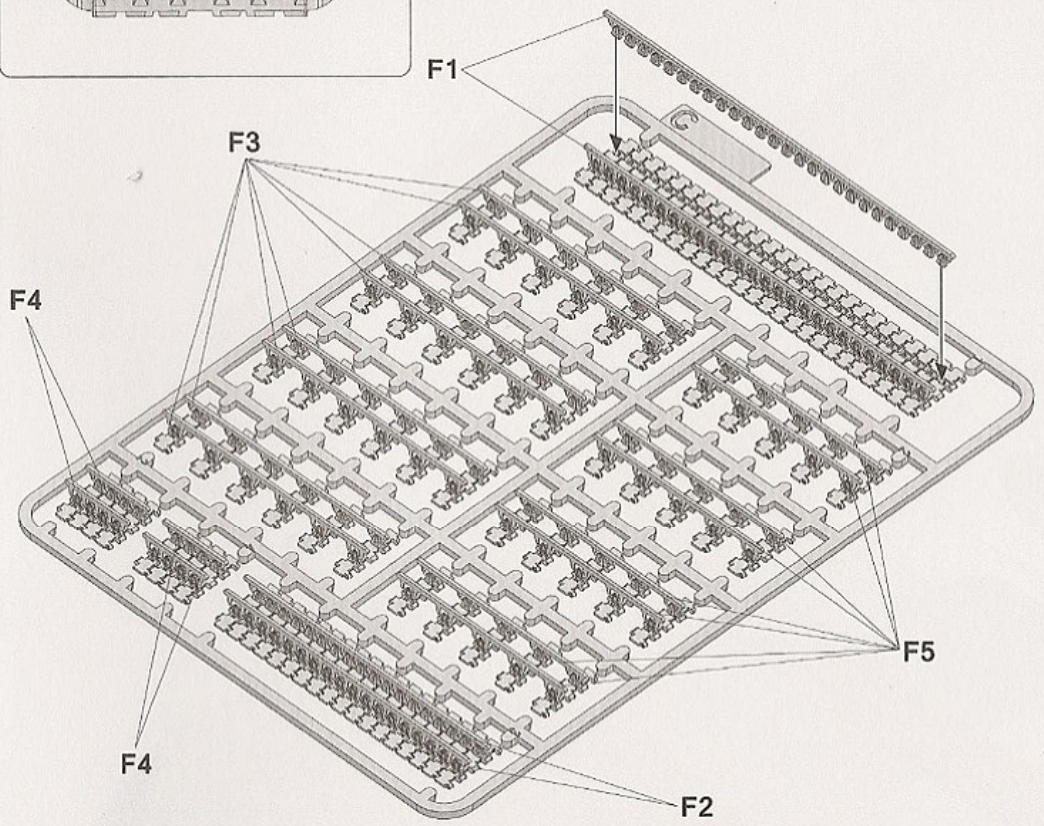
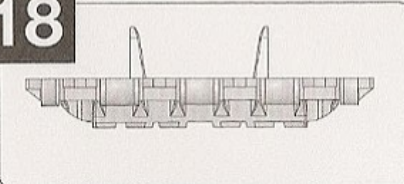

Make 2 E2-10(E2-11)

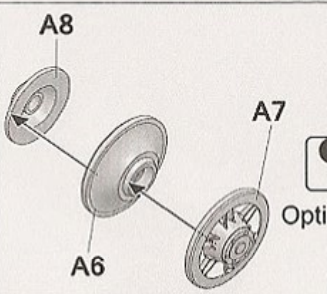

Make 2

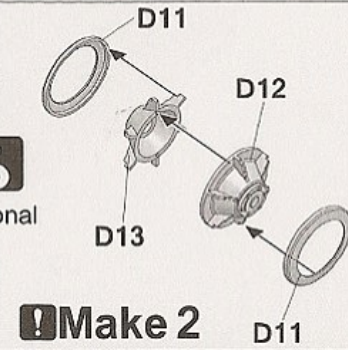

Make 2

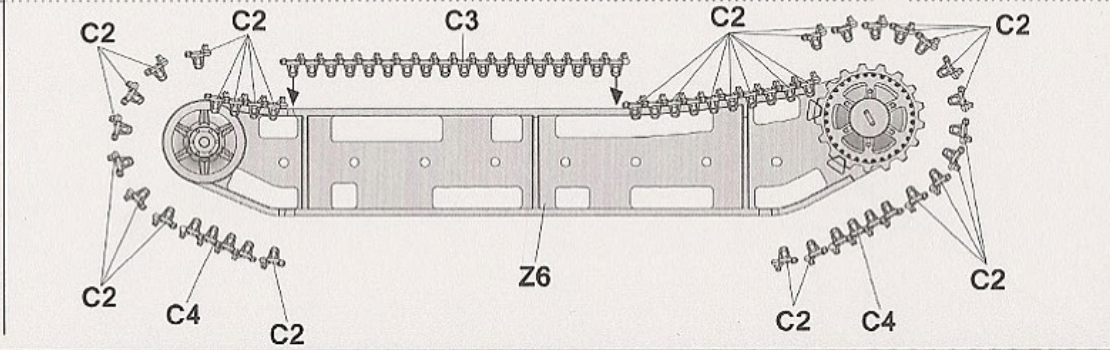
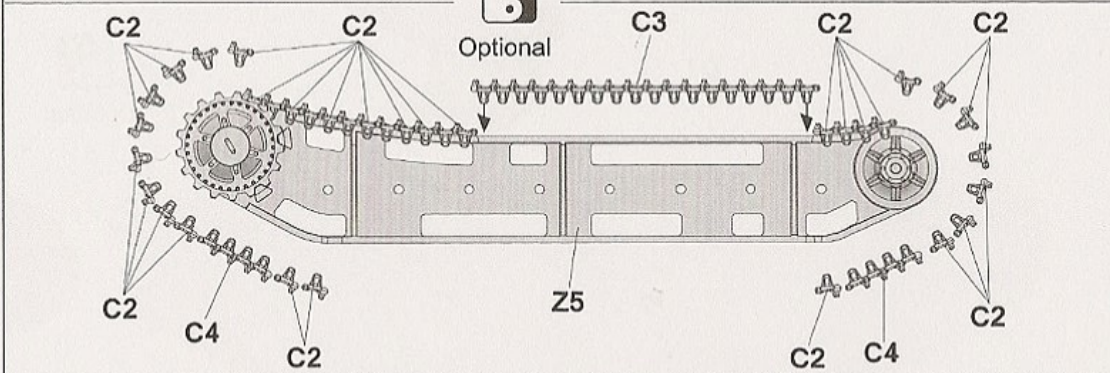
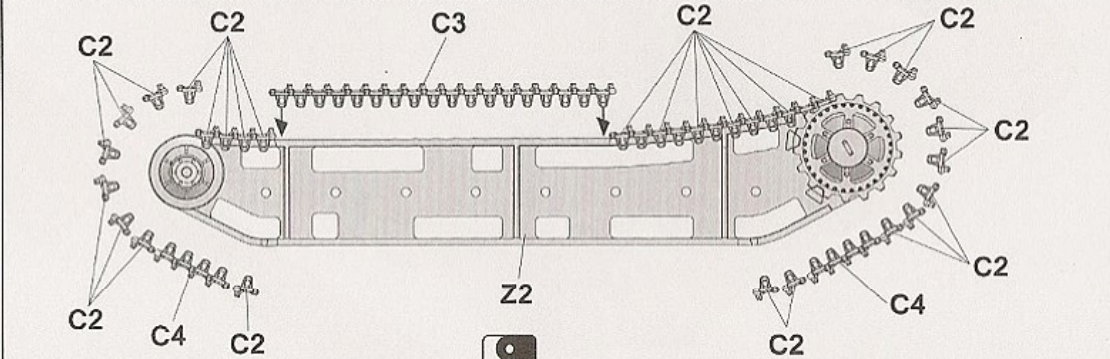
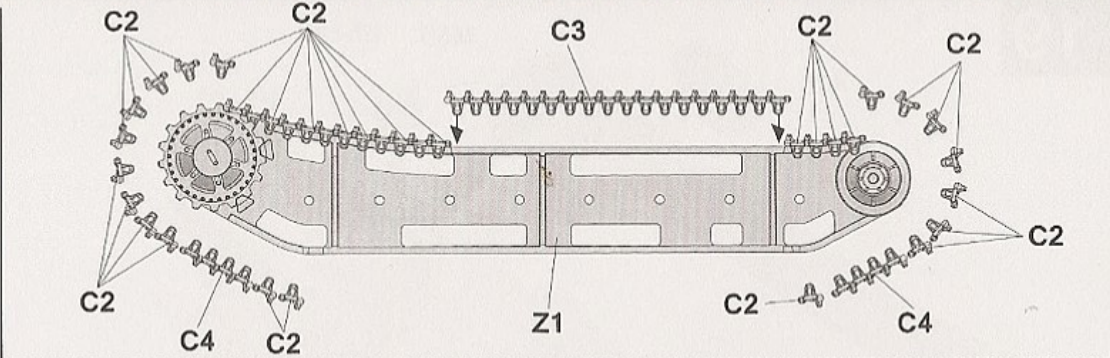



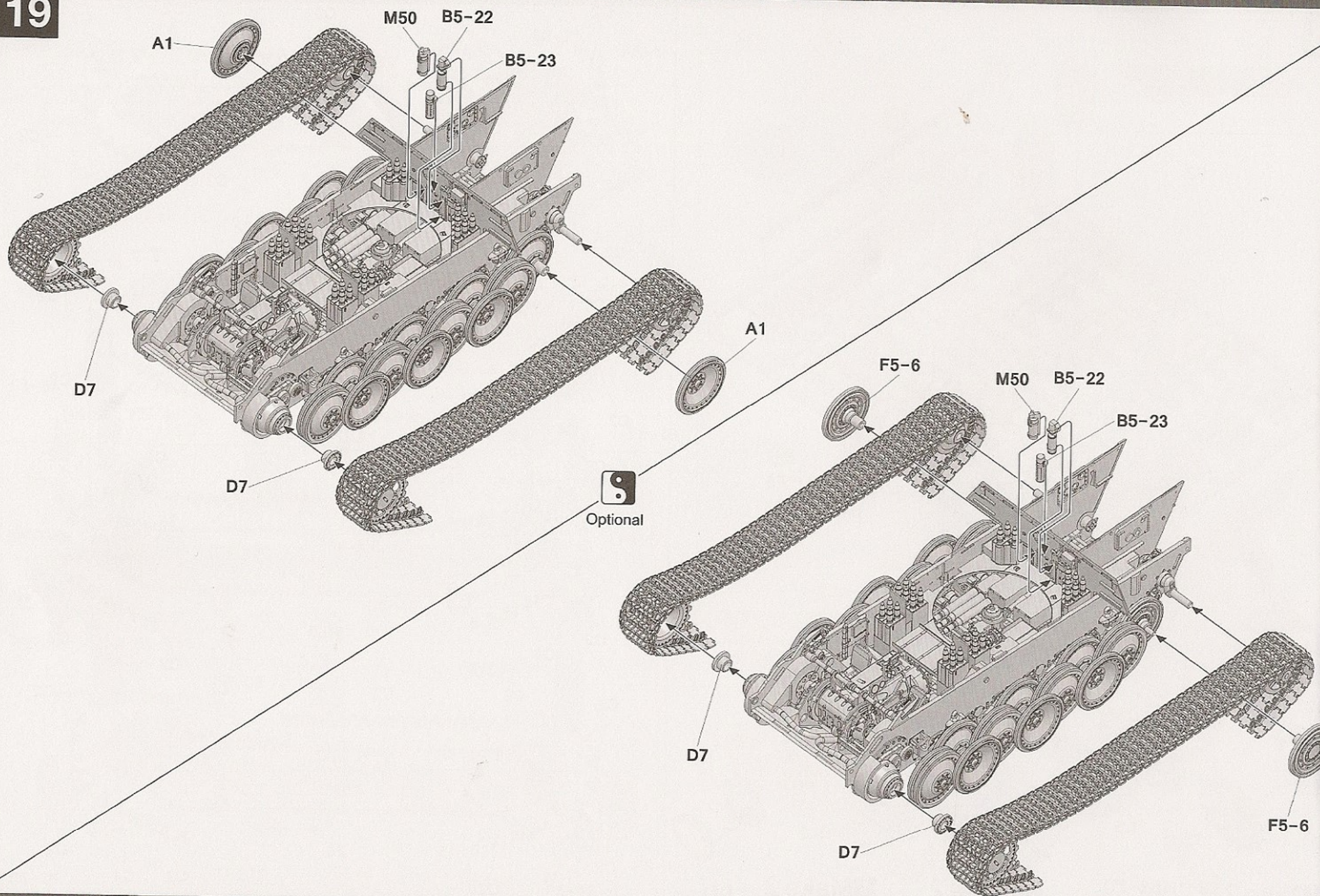



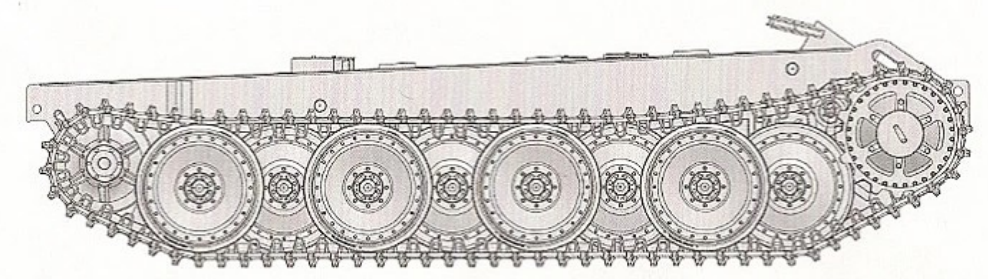
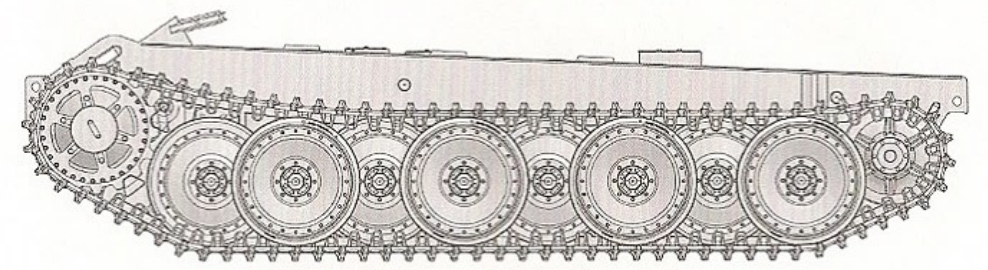
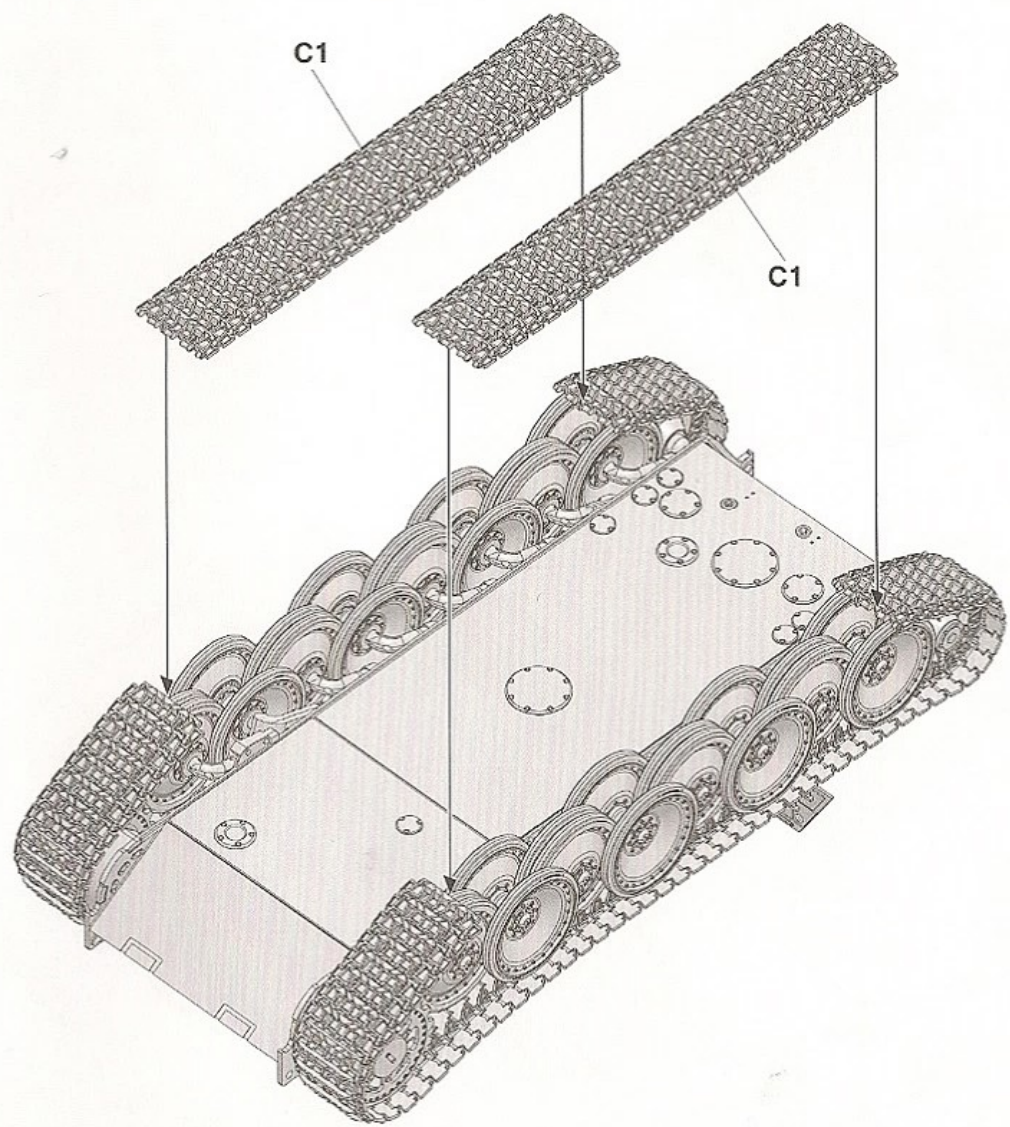



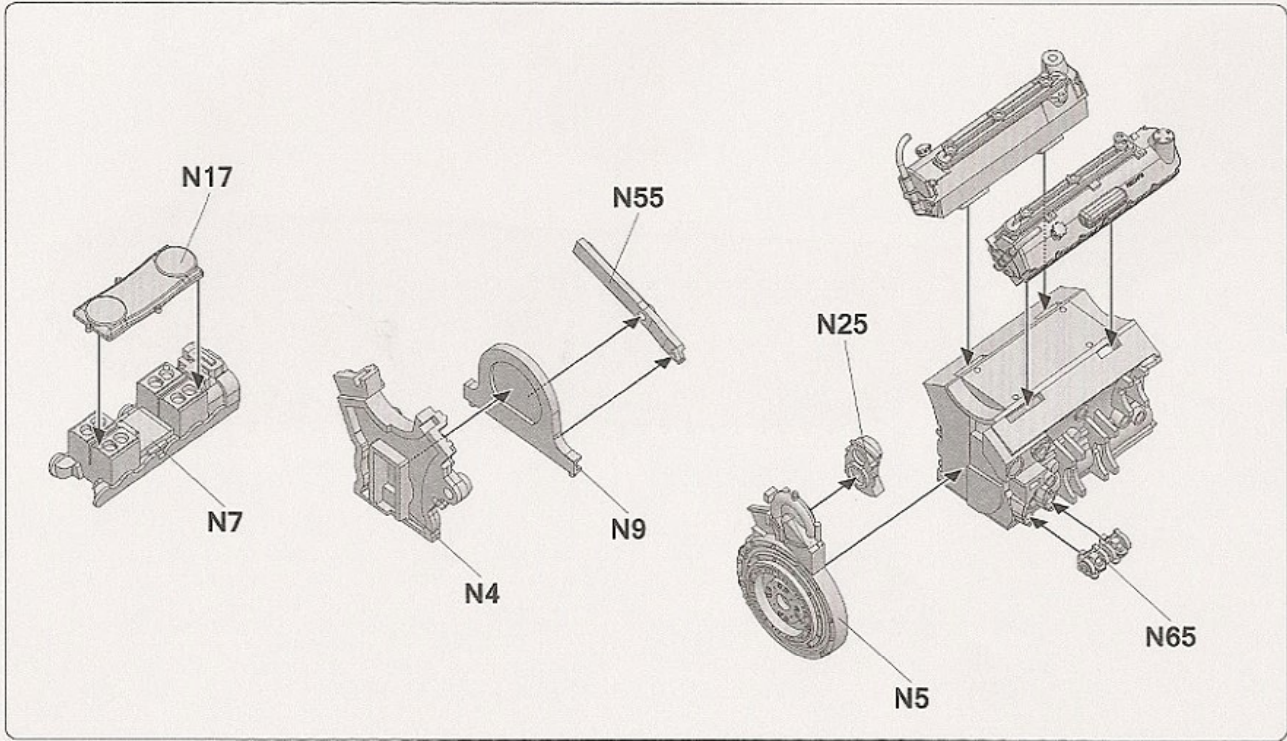
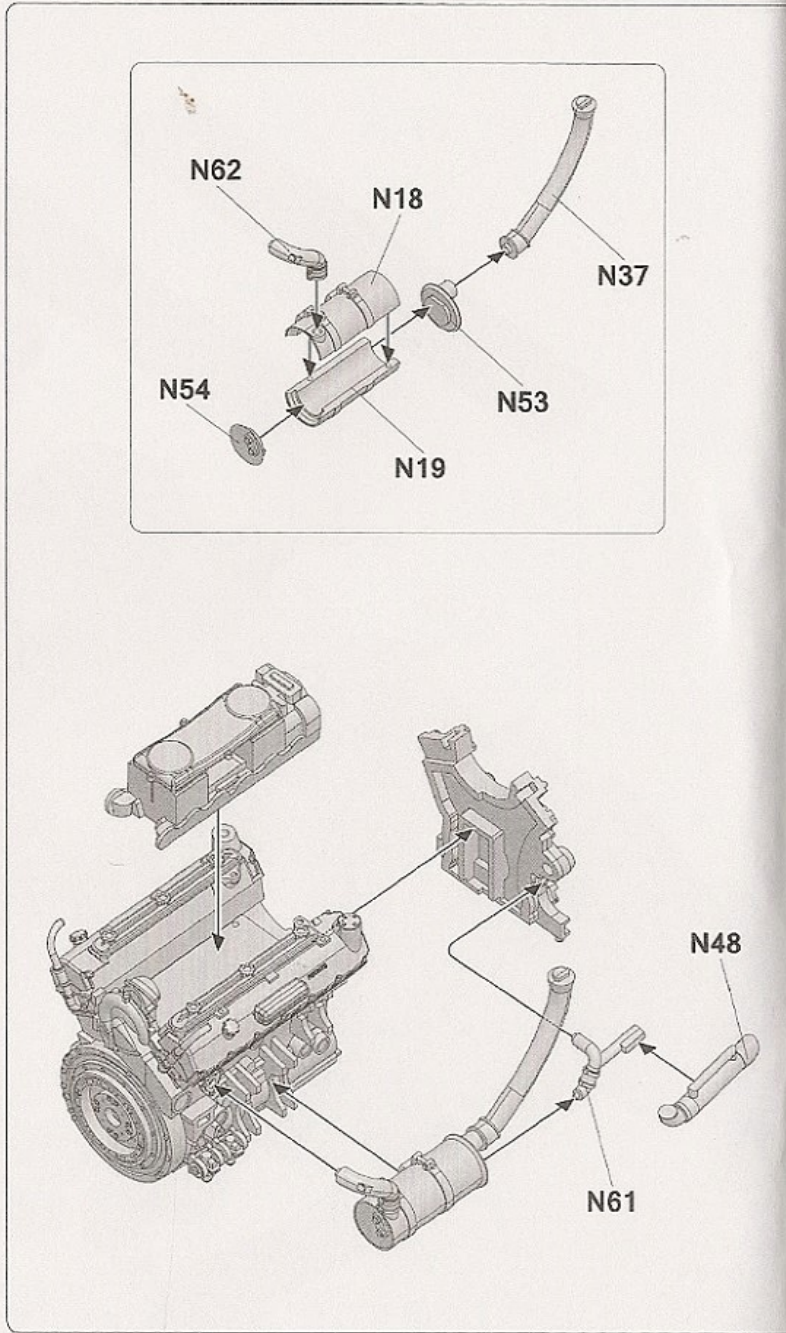
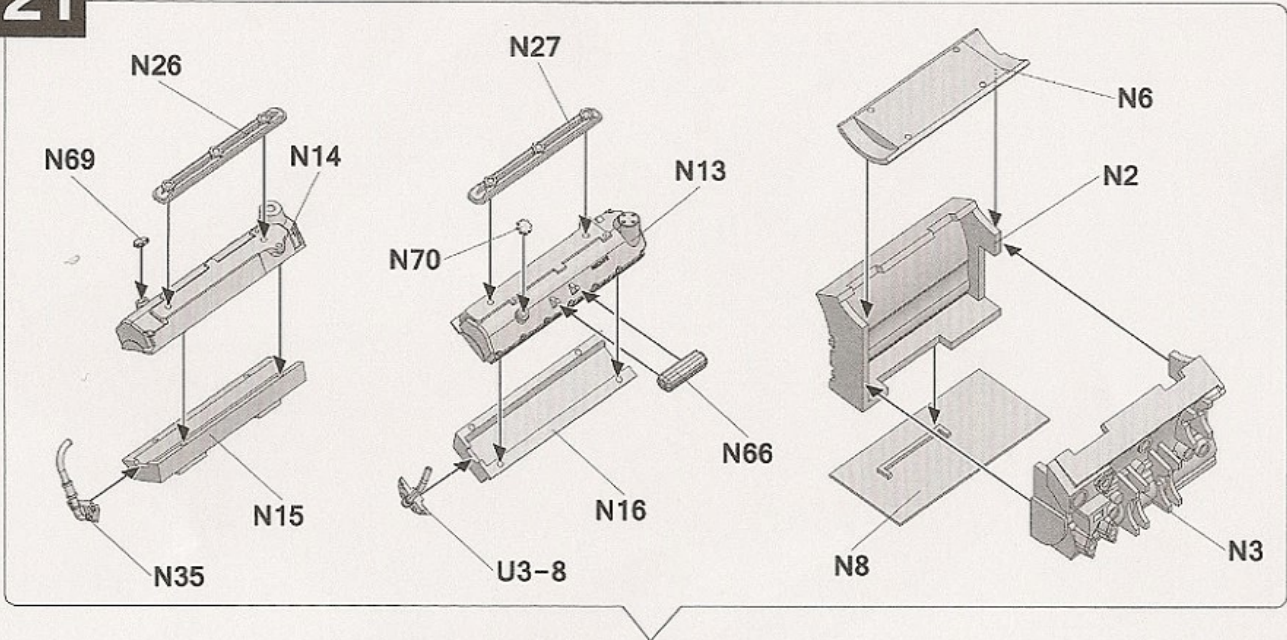



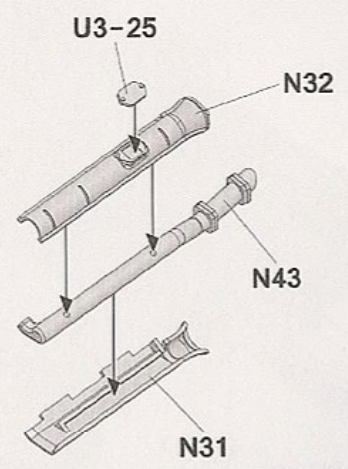
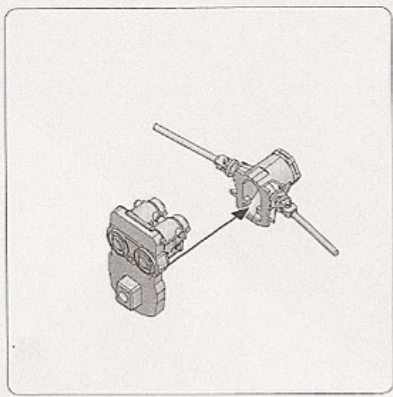
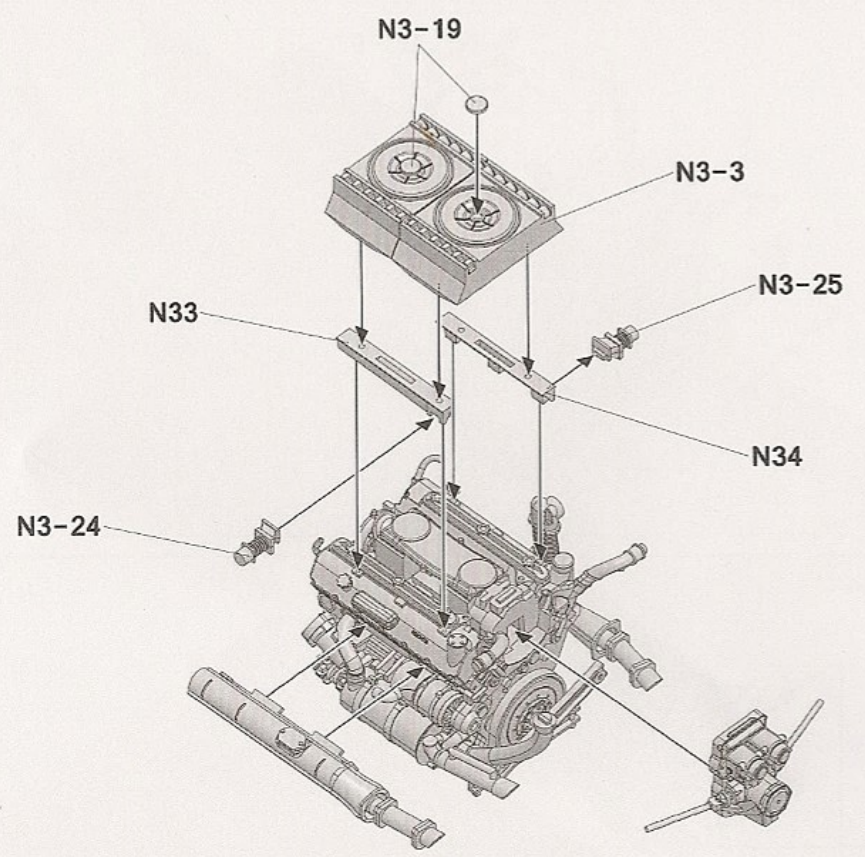
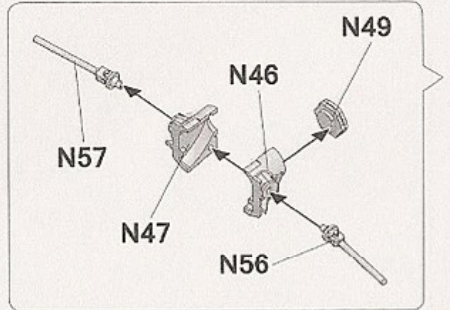
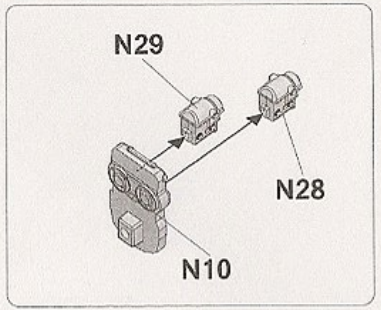
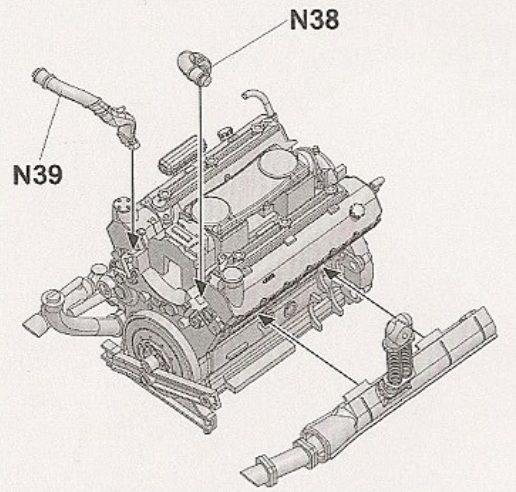
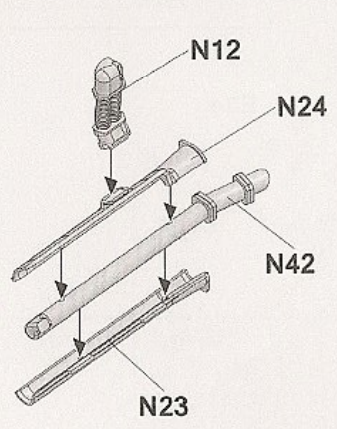
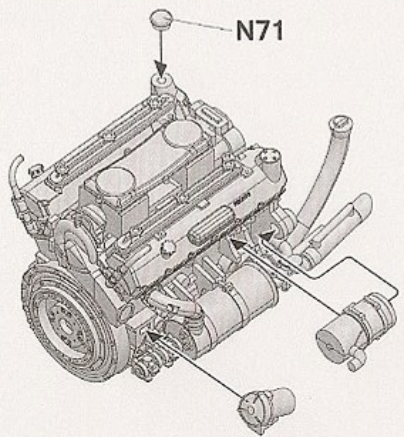
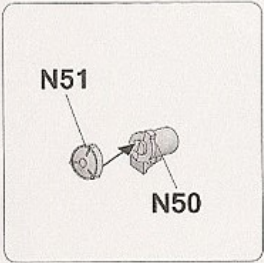
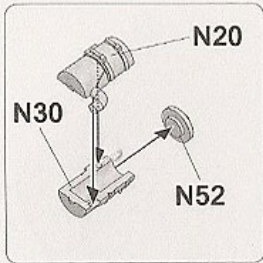



23

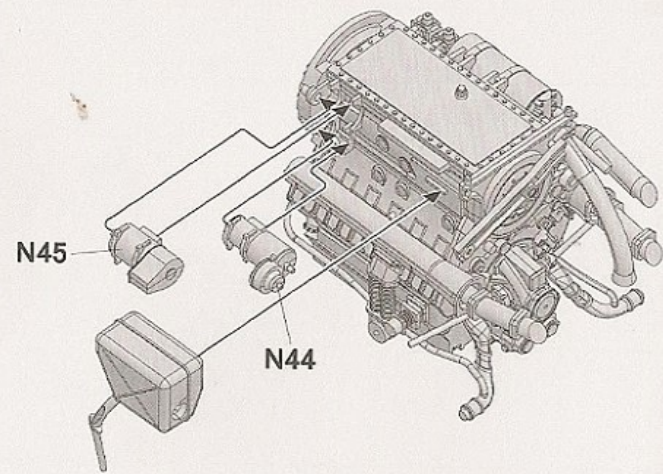
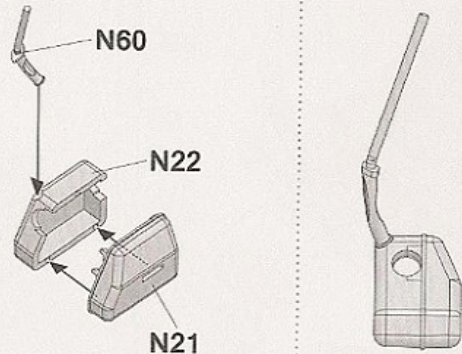
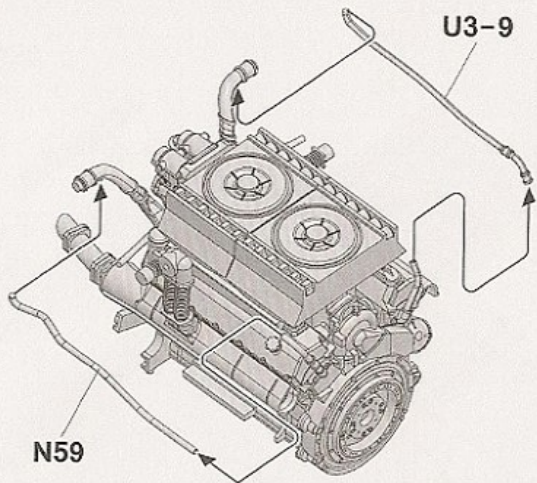

24

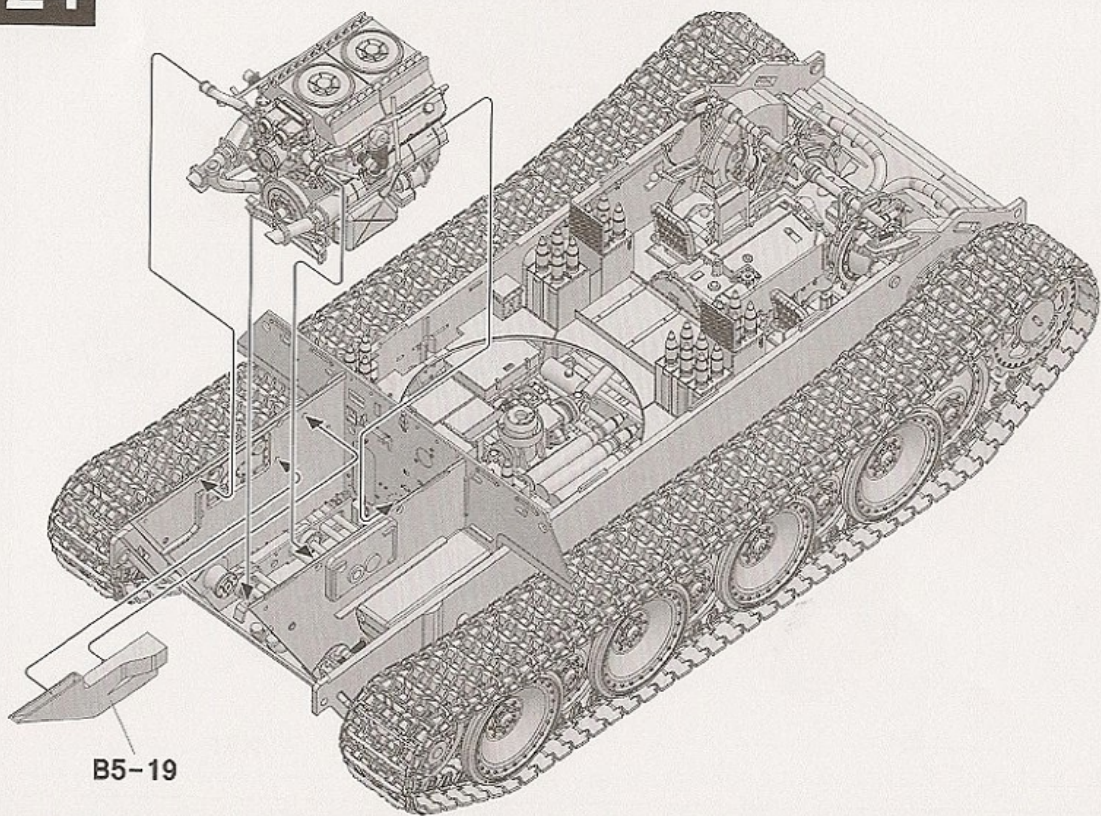

25

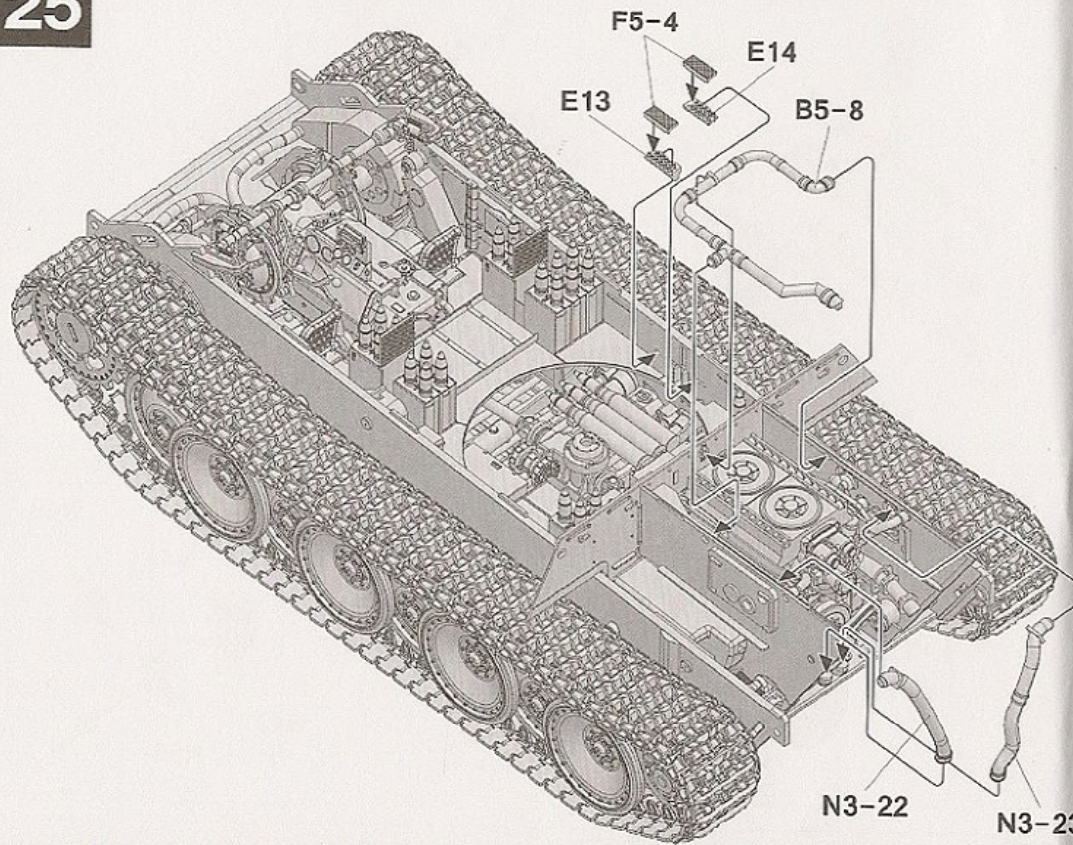



26

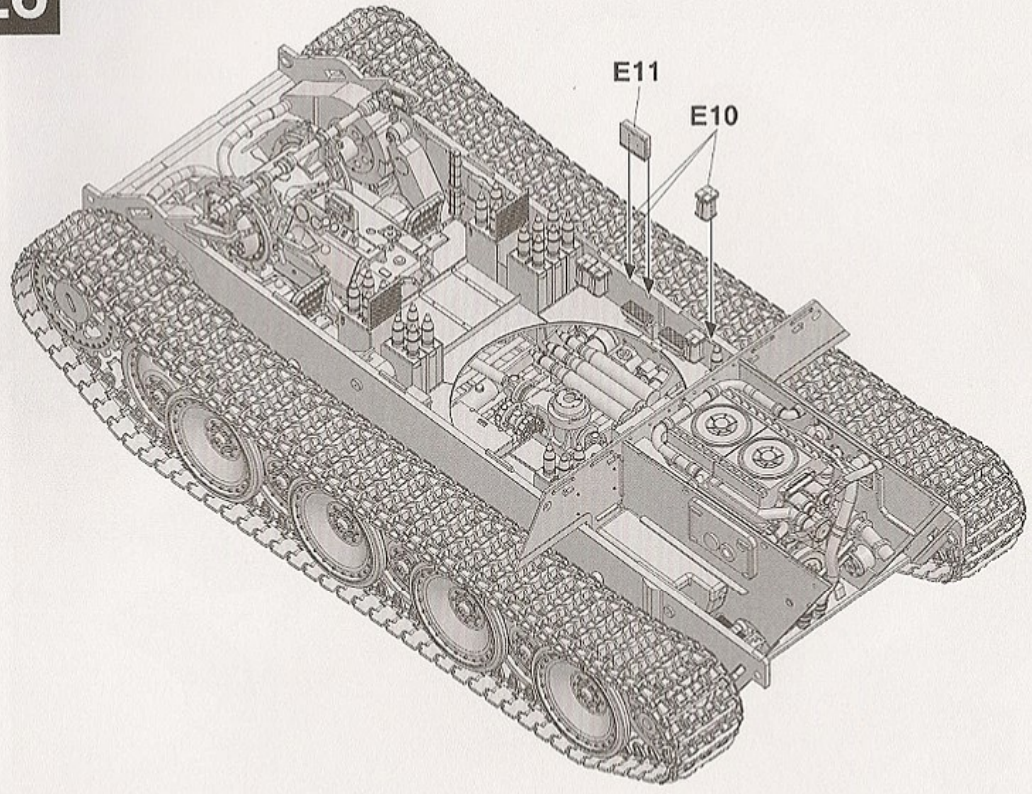

27

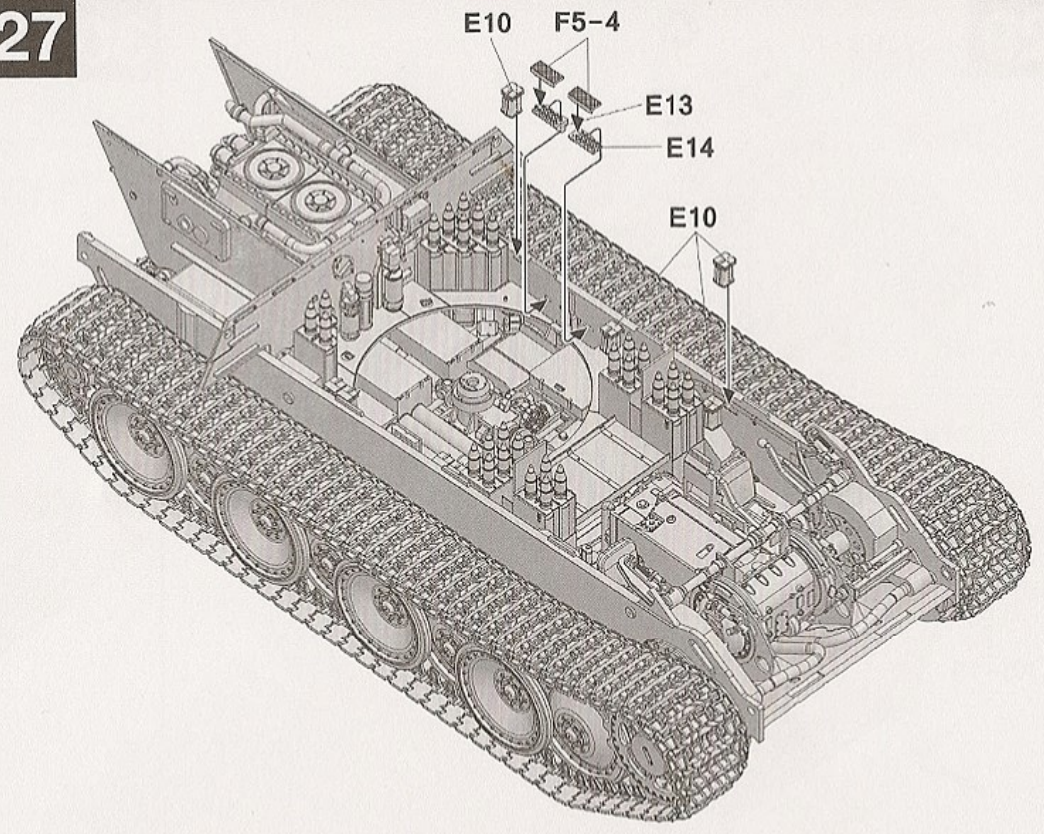

28

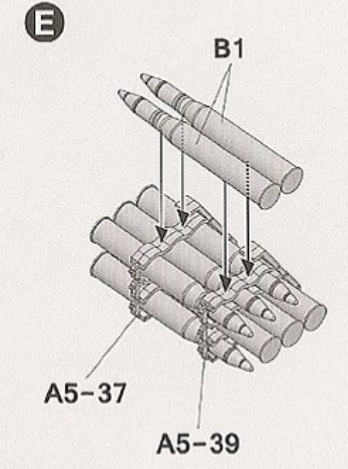
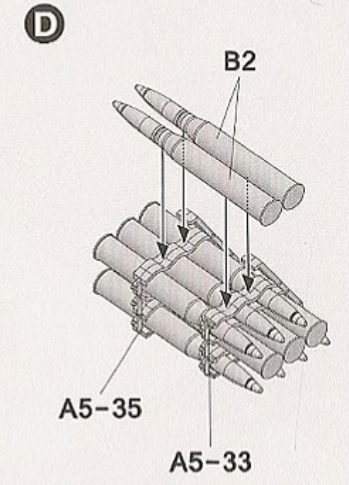
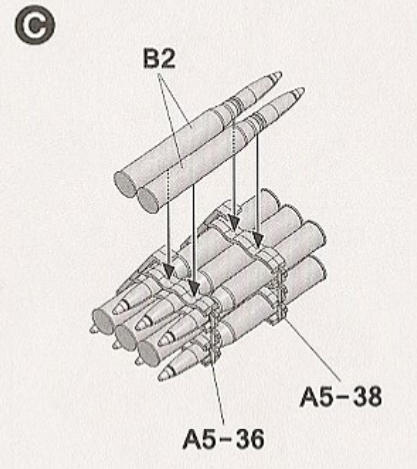
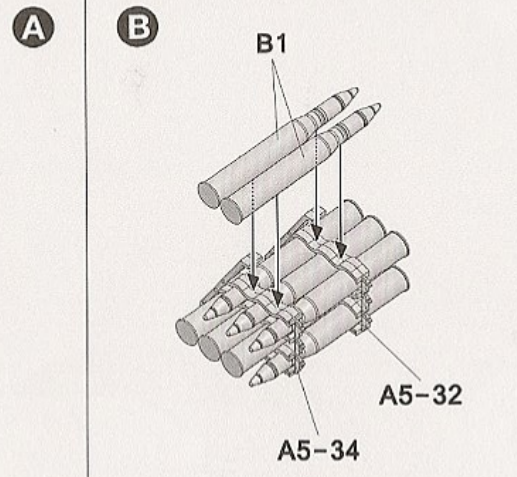
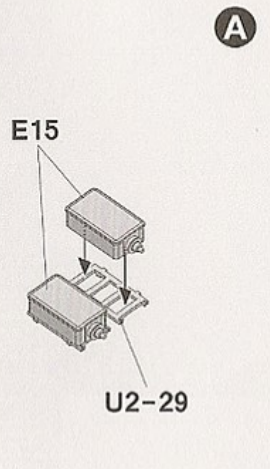



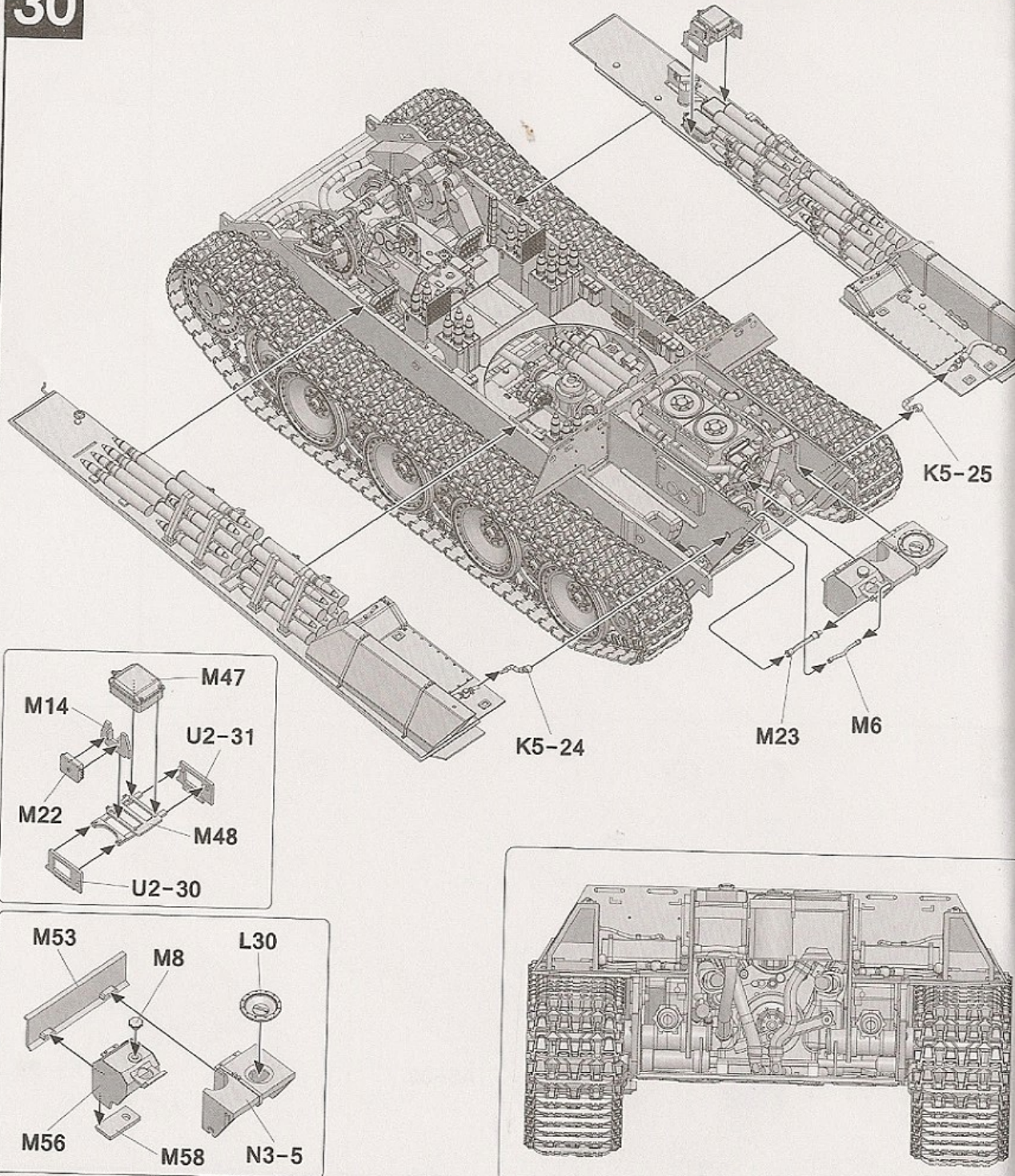
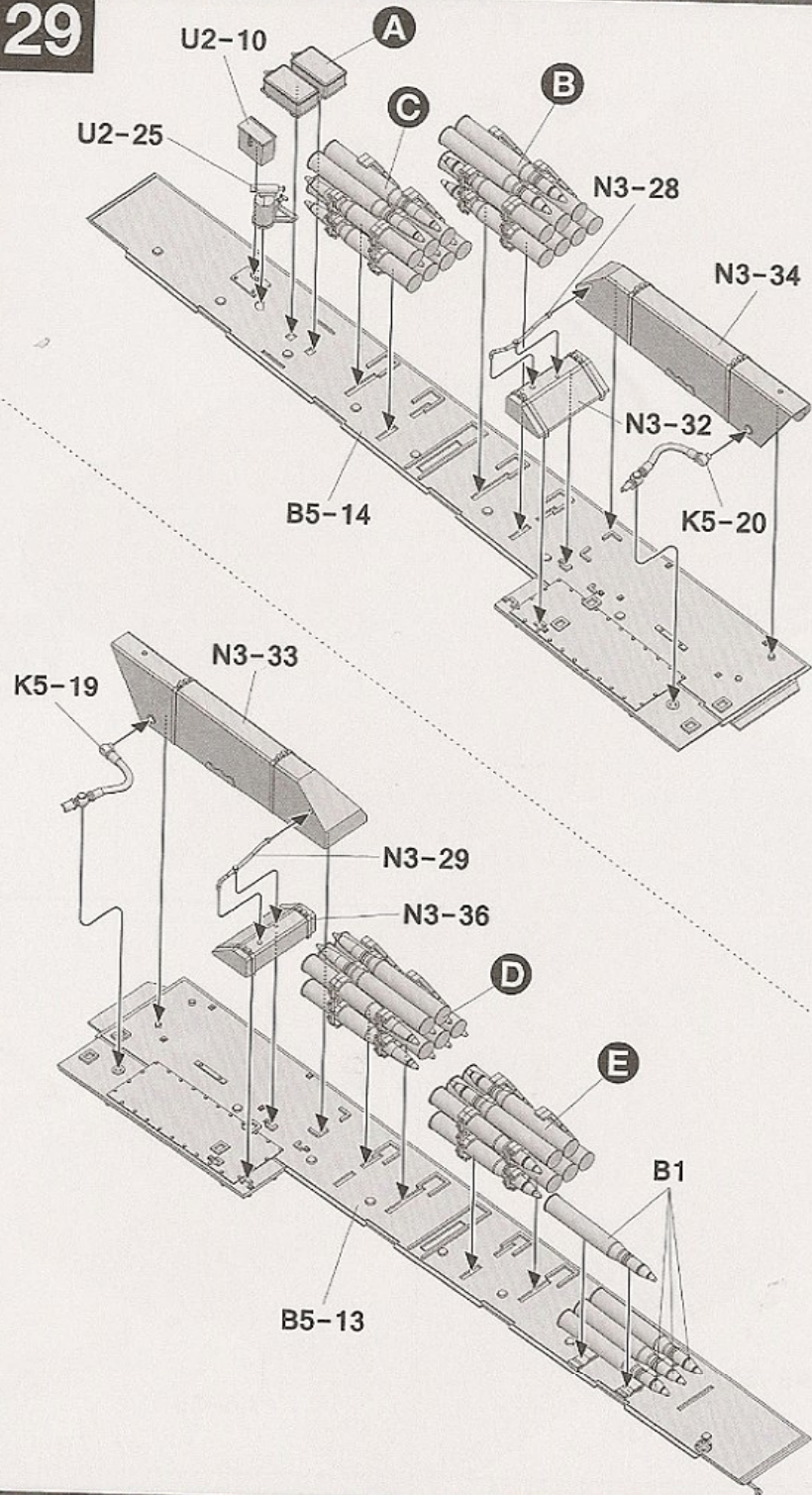



# 31

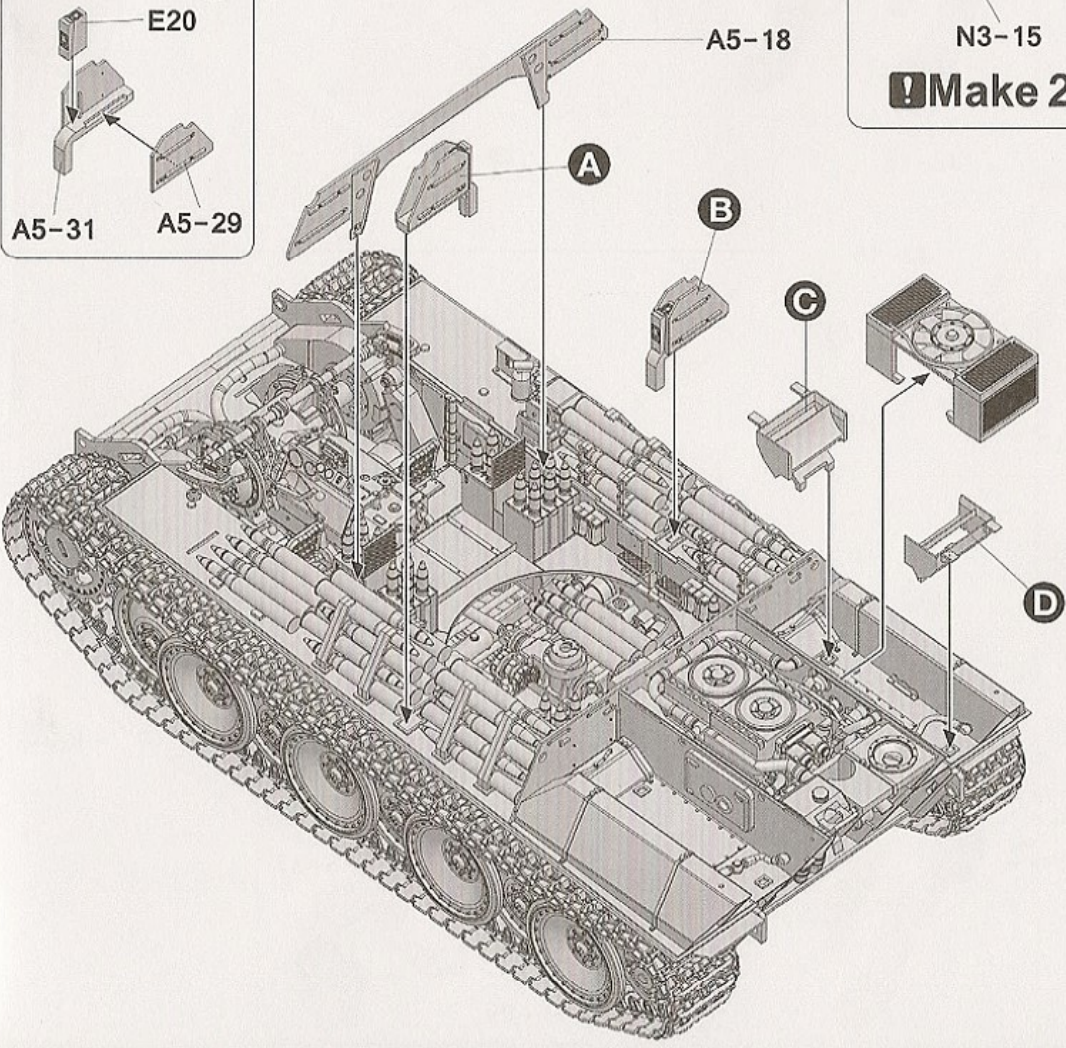
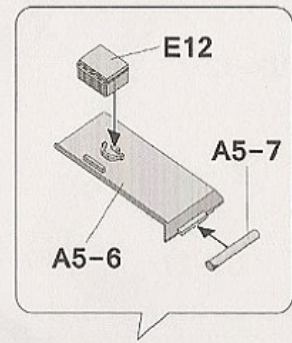
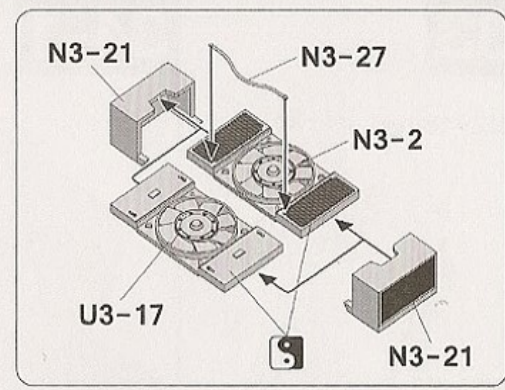
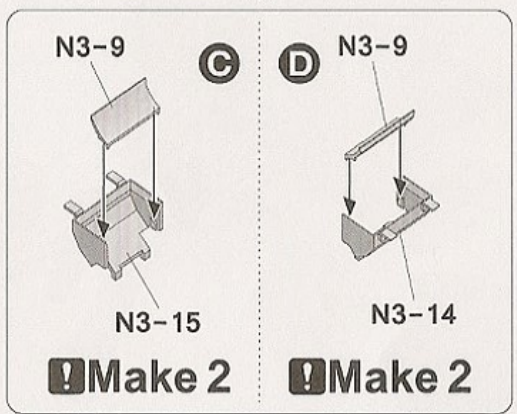
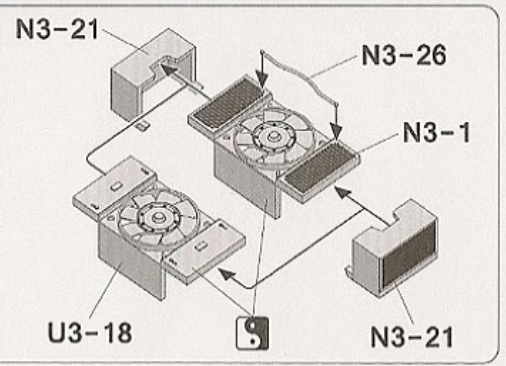
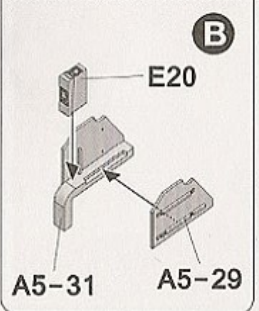
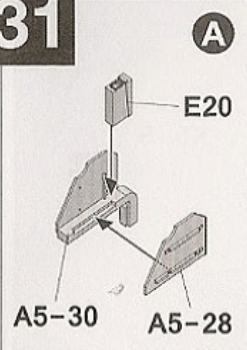

# 32

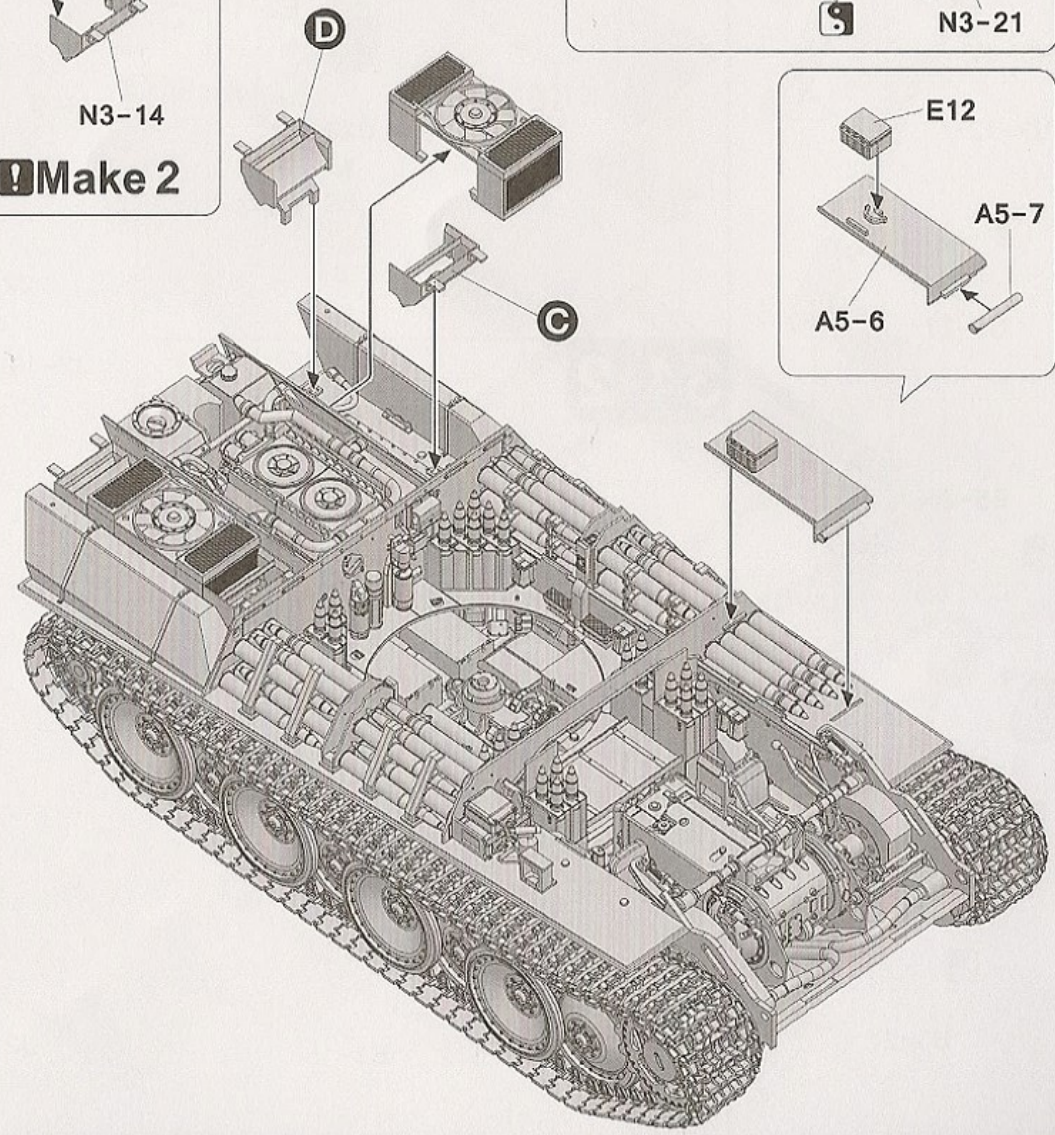

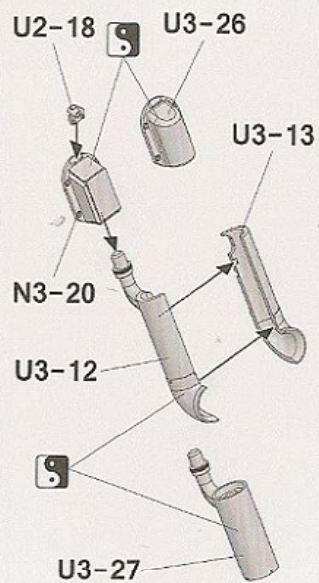
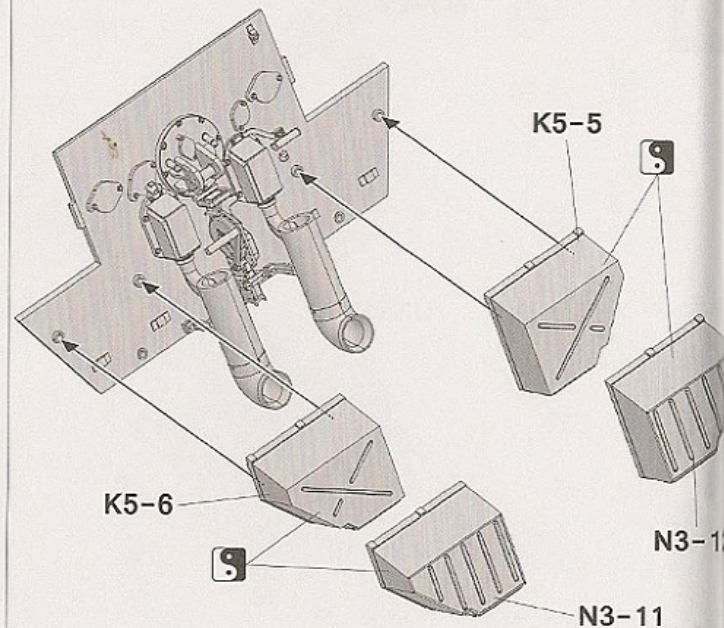
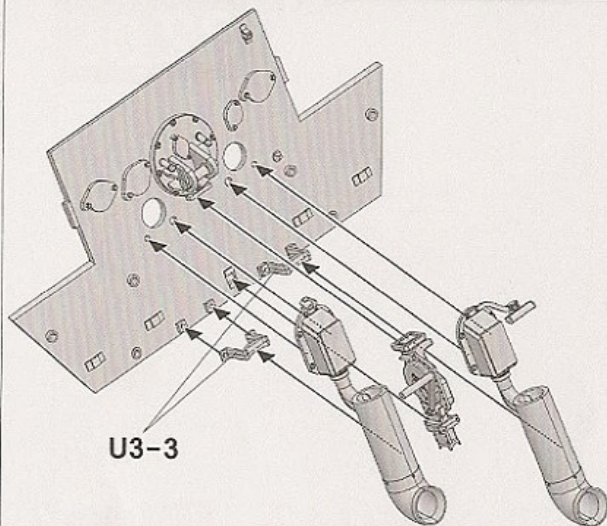
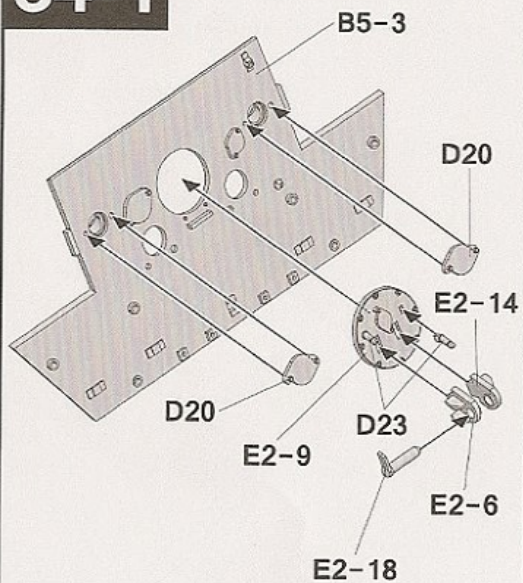
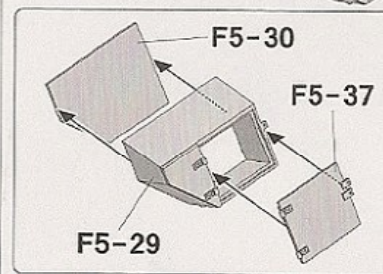
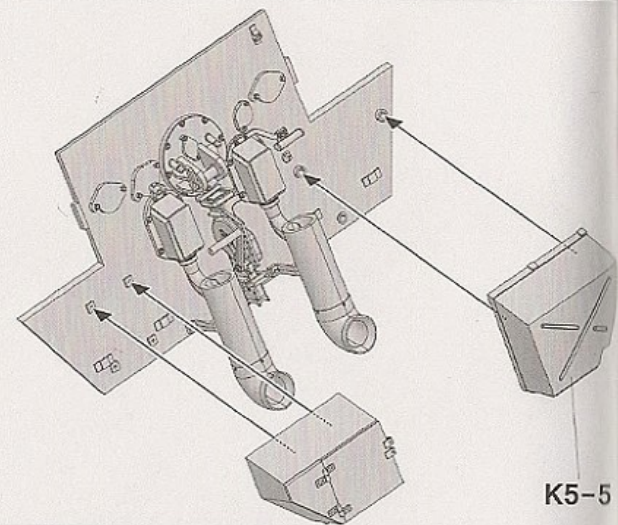
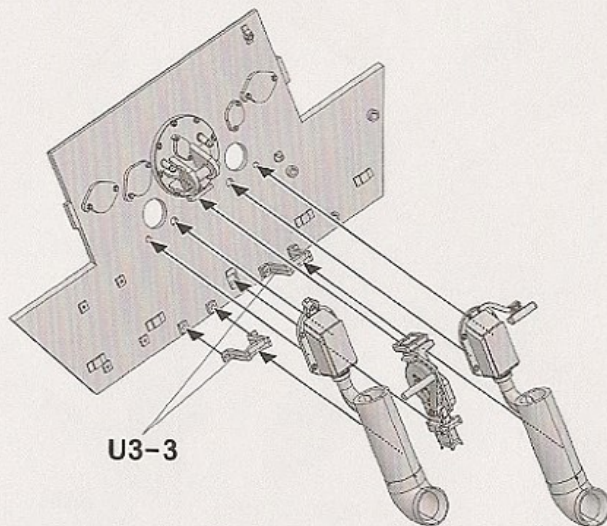
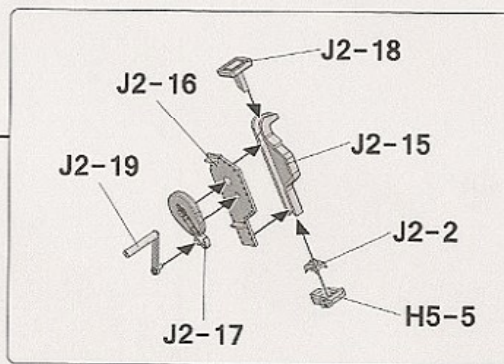
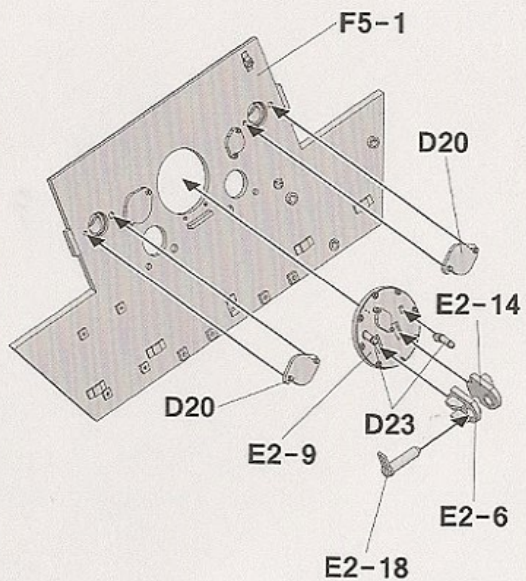
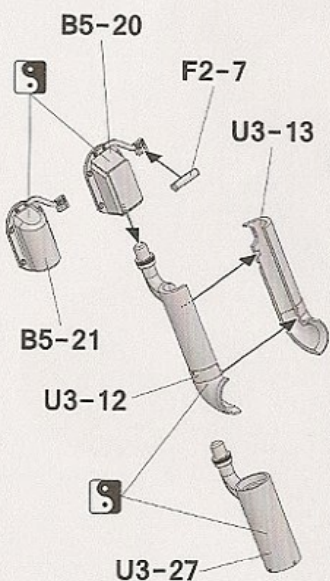

**33****34-1****34-2**



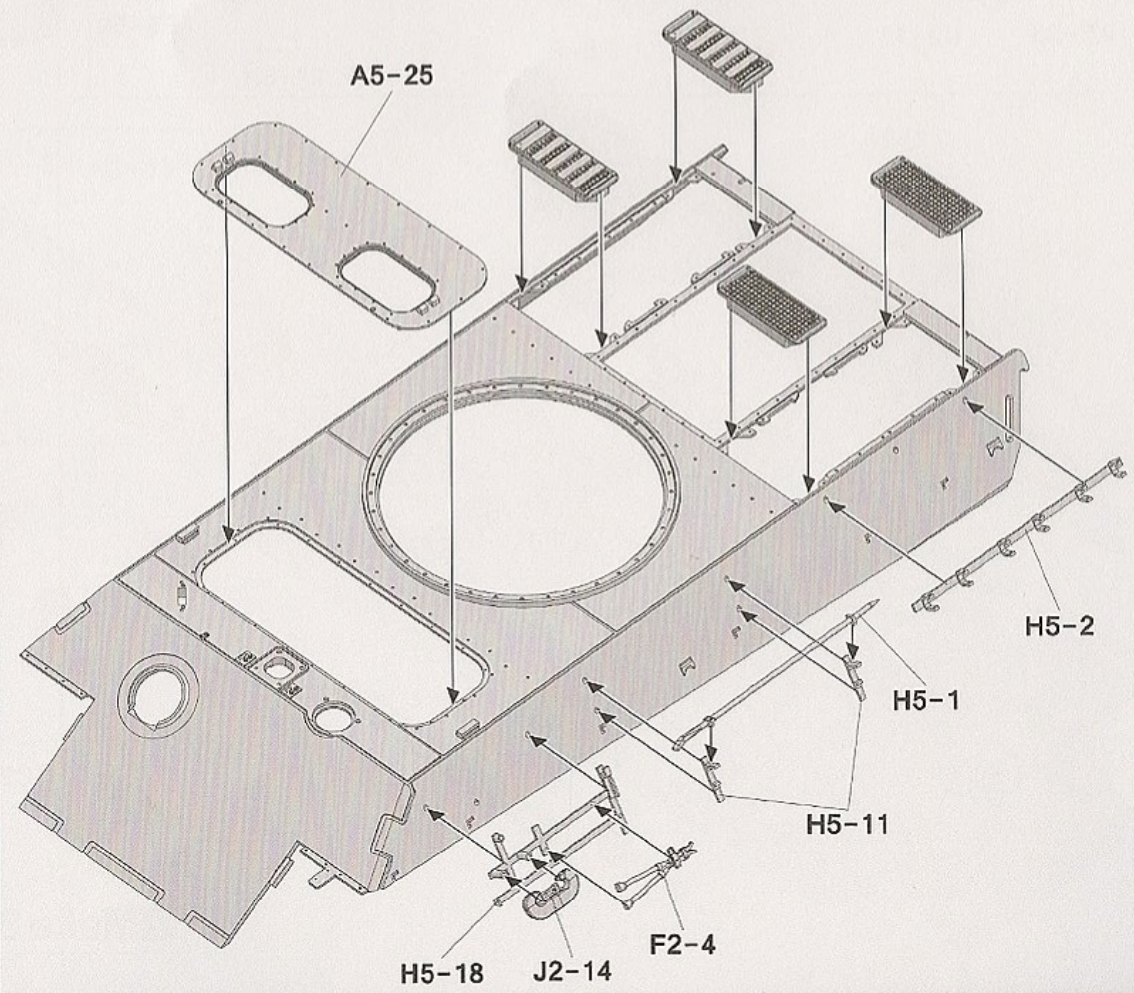
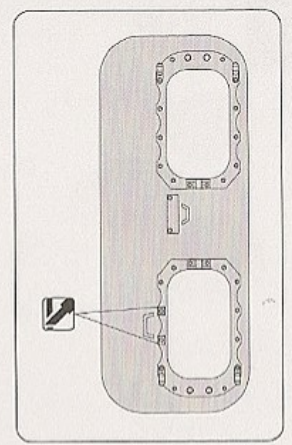
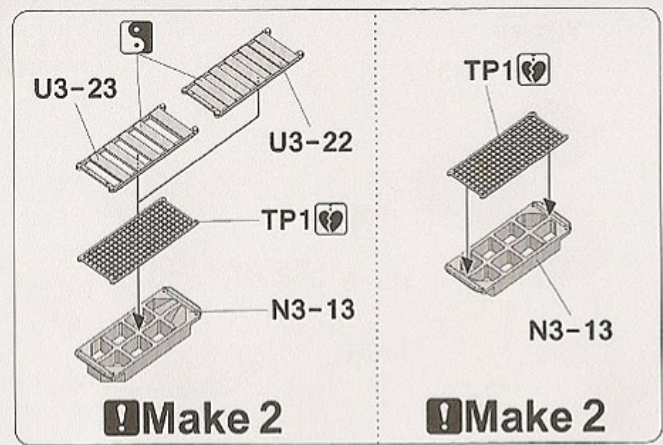
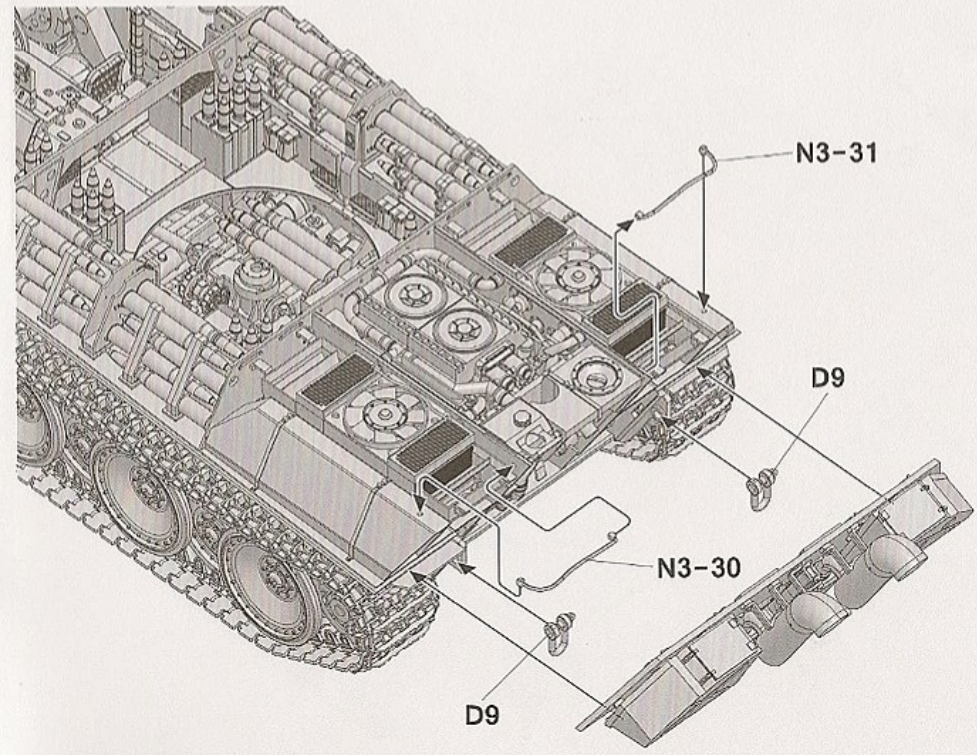
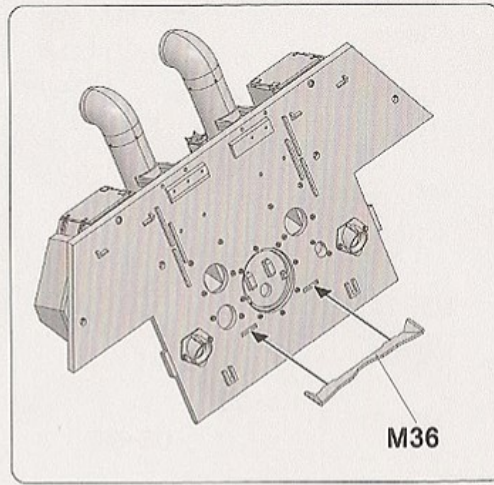



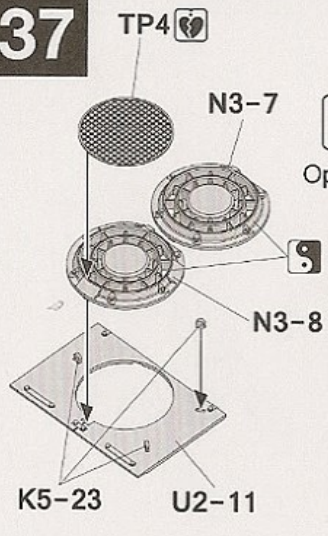

Optional

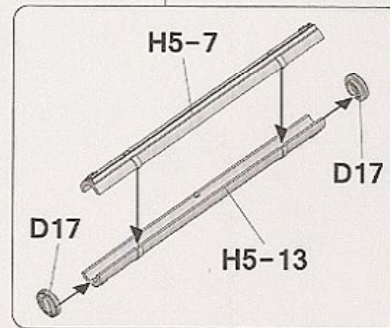
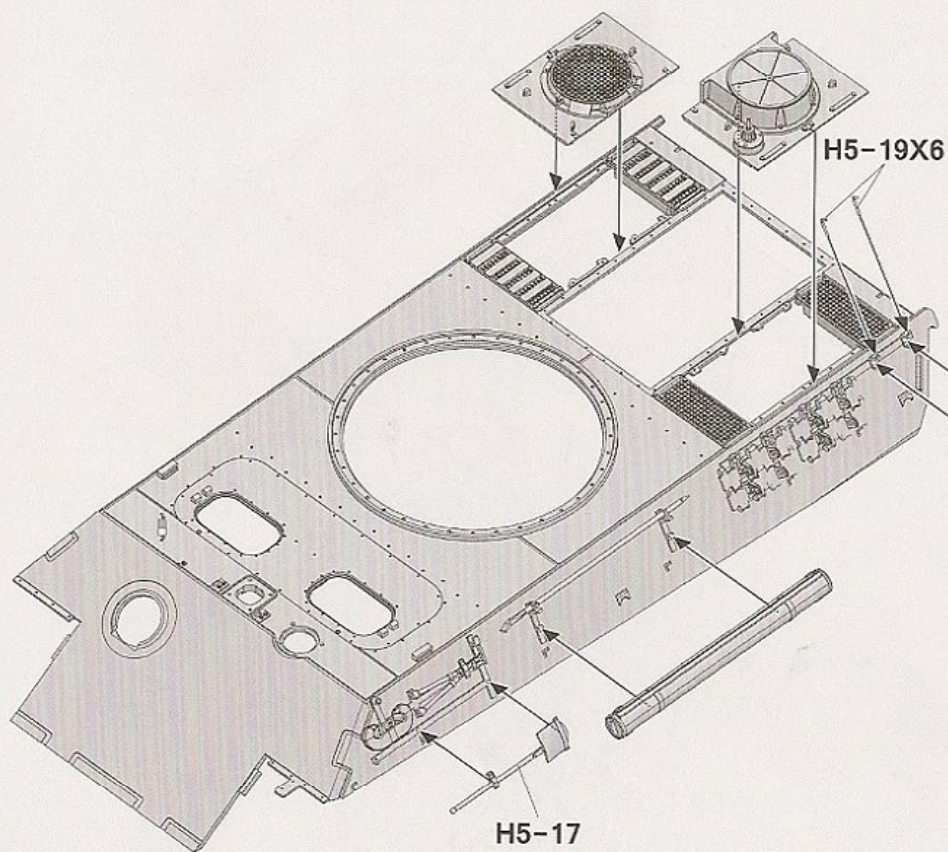
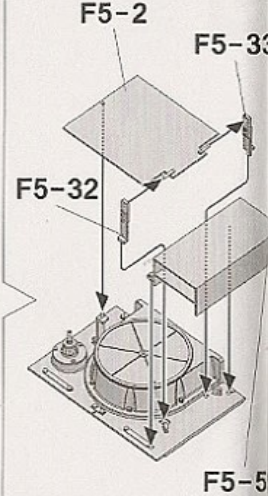
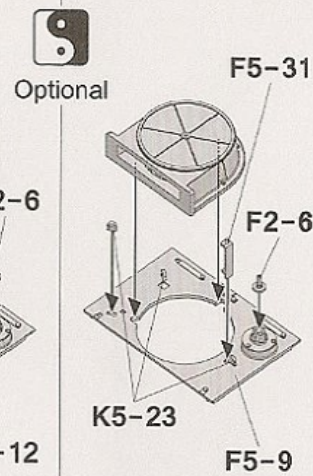
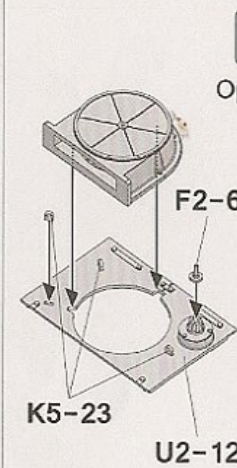
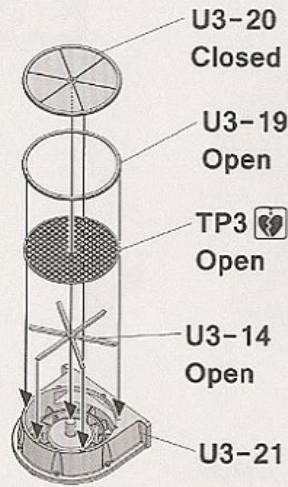
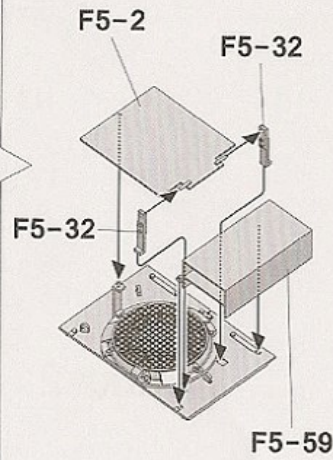
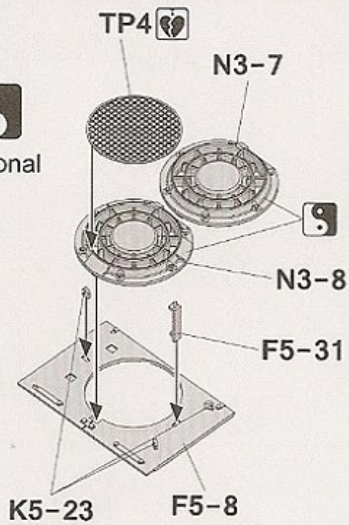

Optional

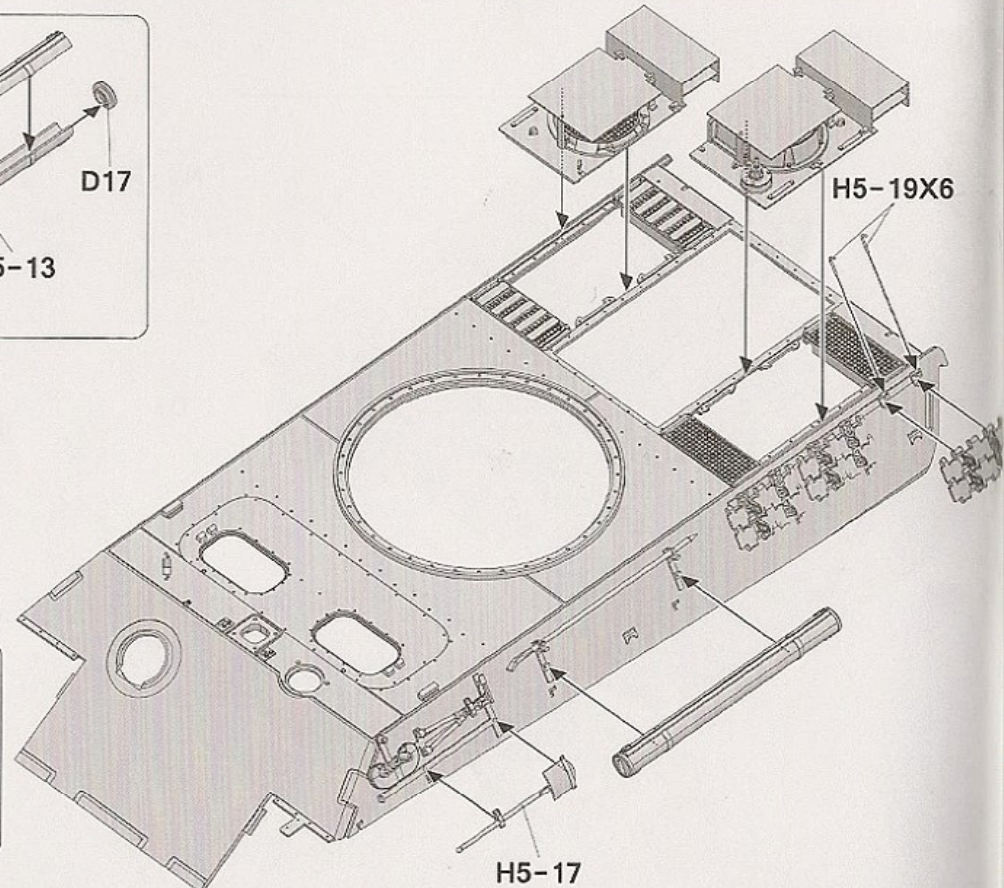
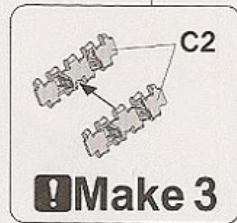



38

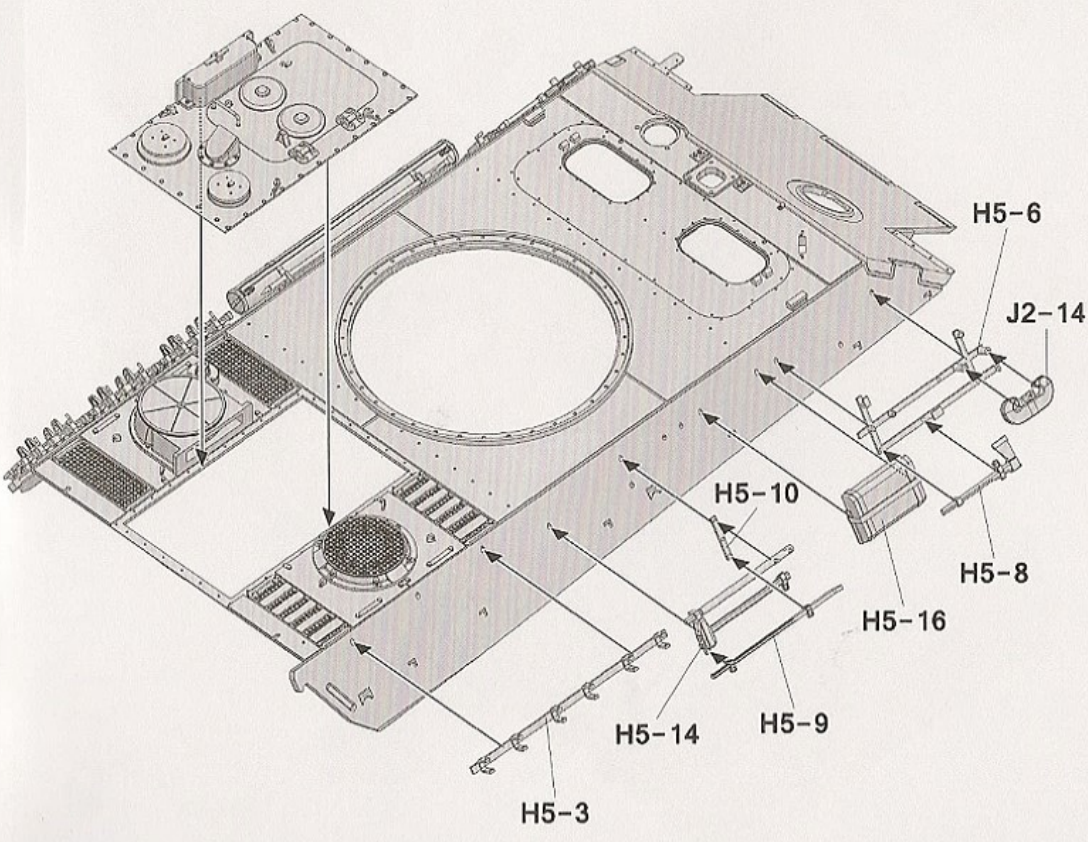
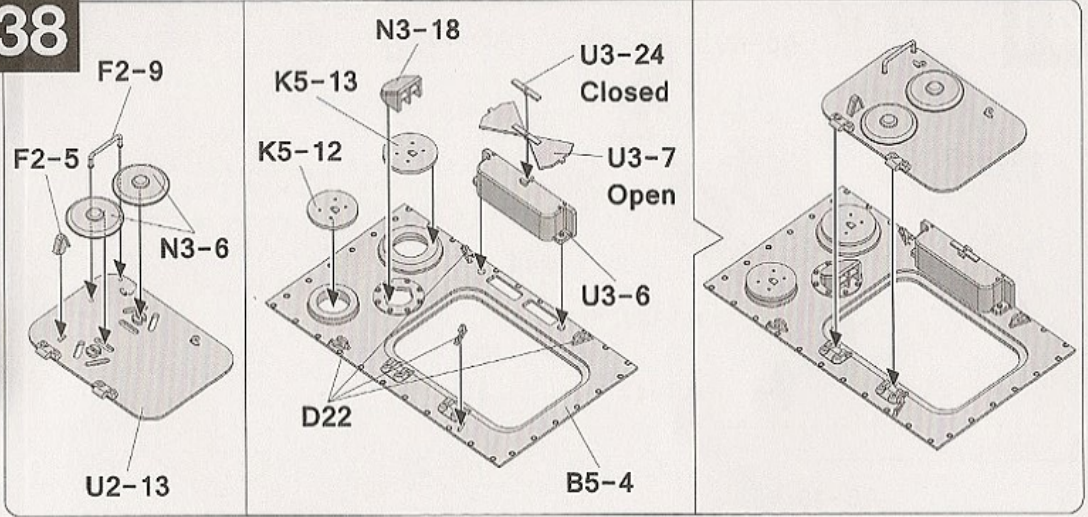

39

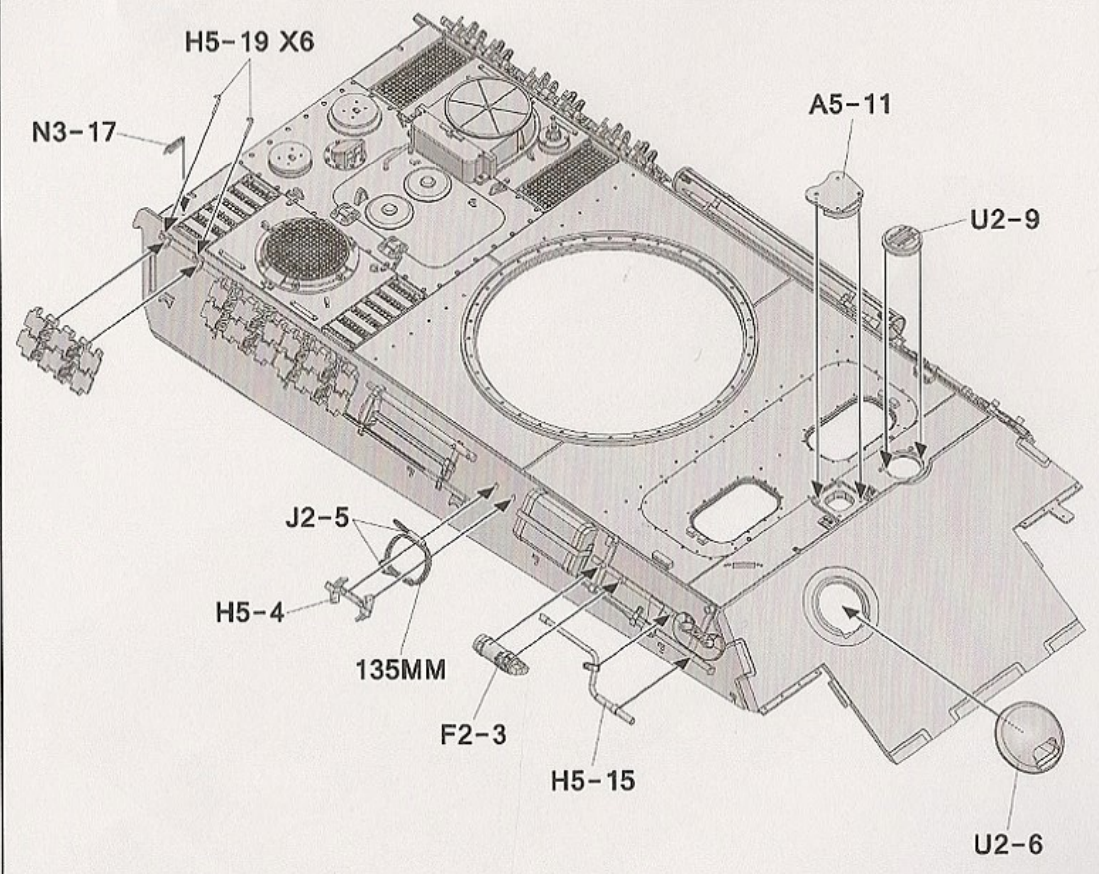
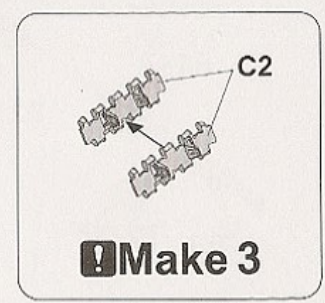



40

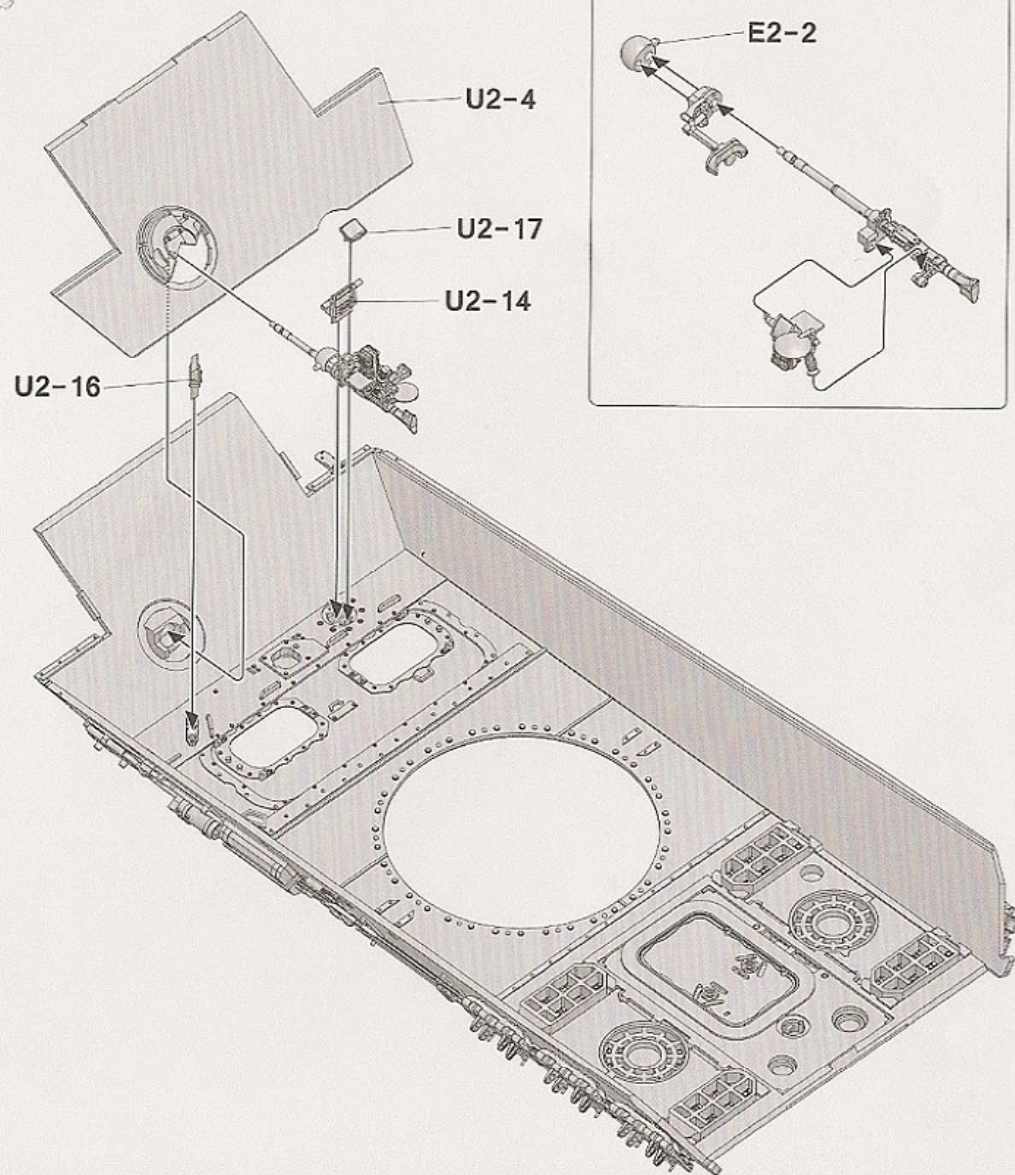
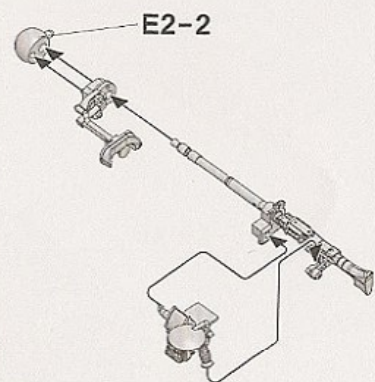
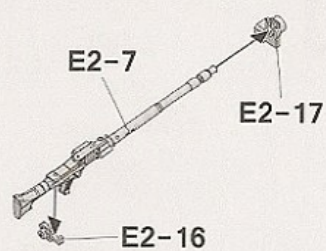
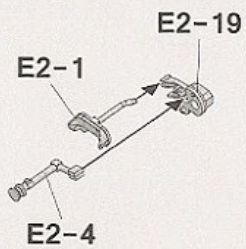
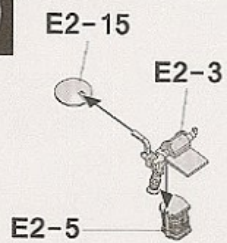

41

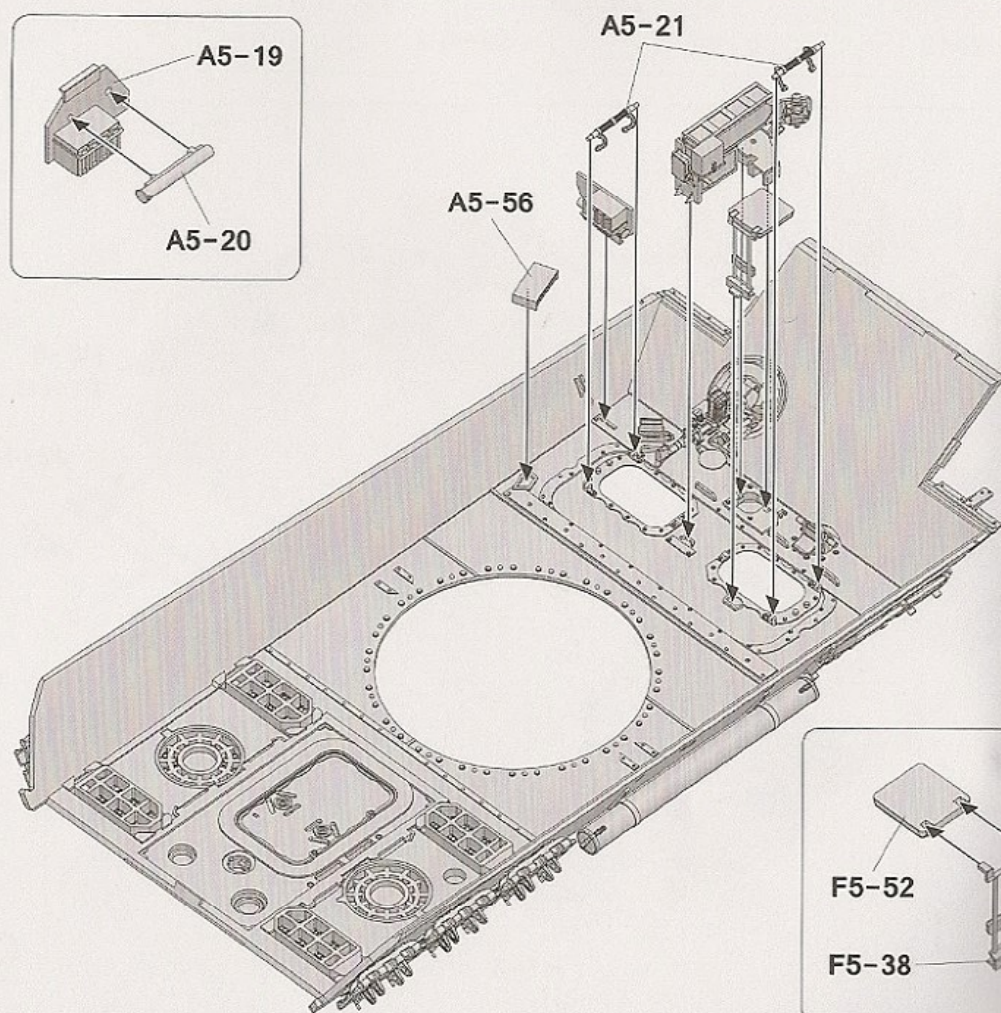
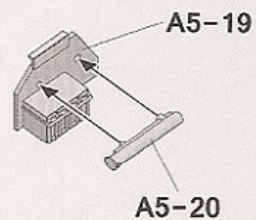
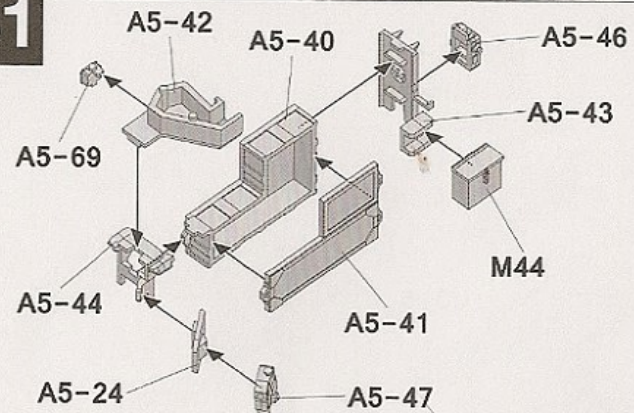

F5-52

F5-38



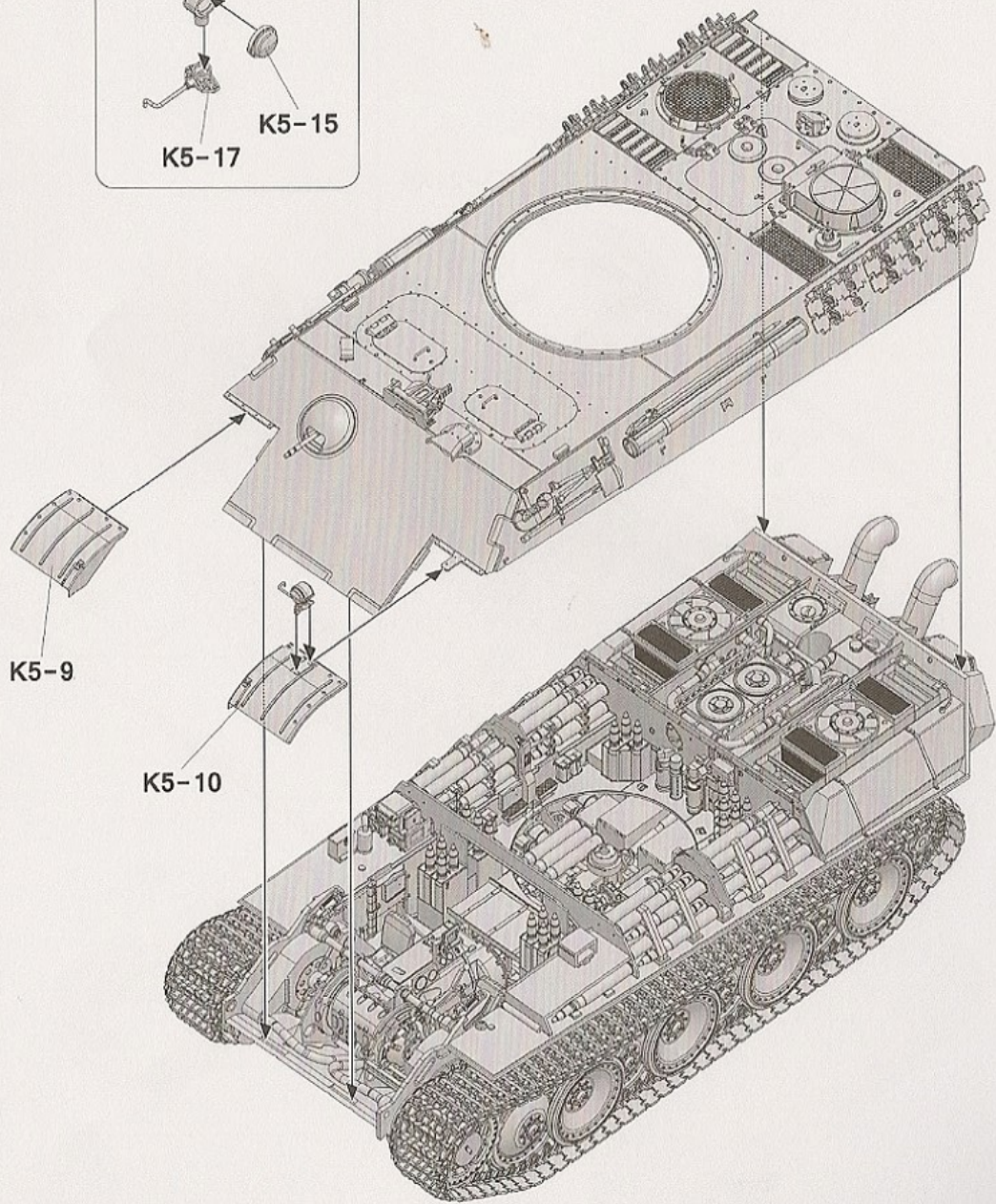
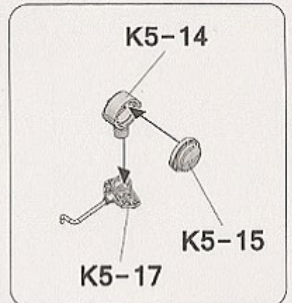
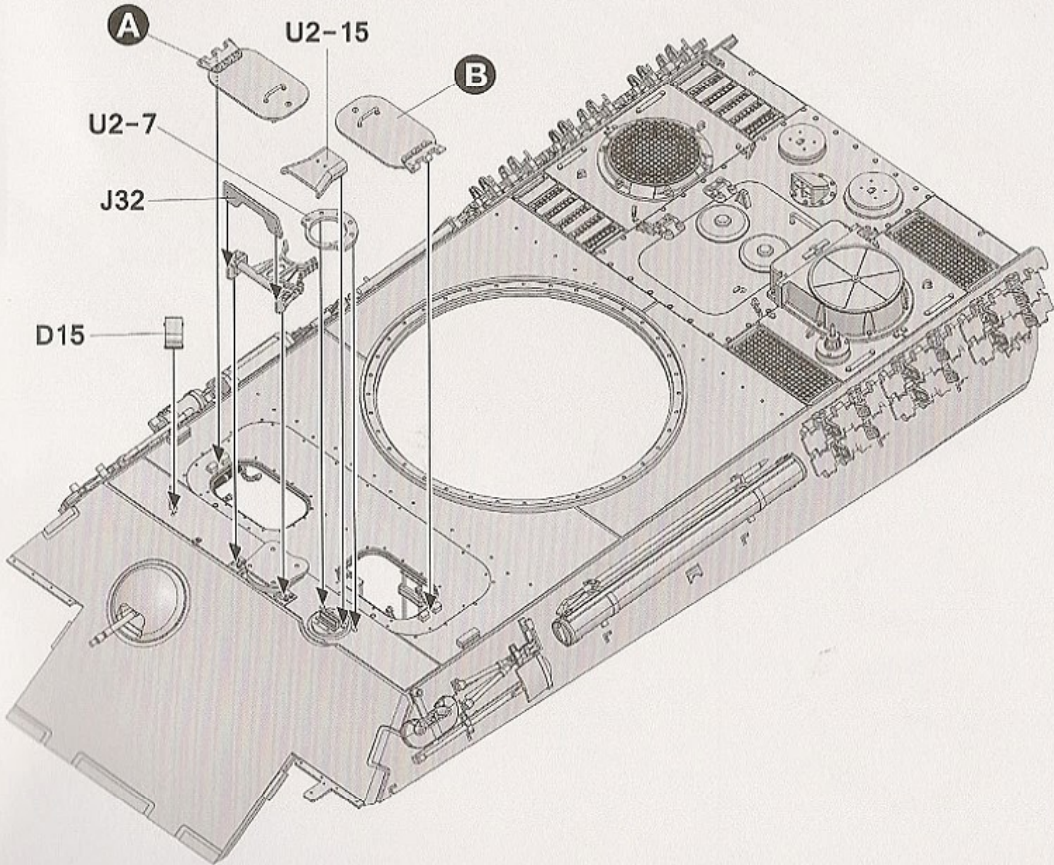
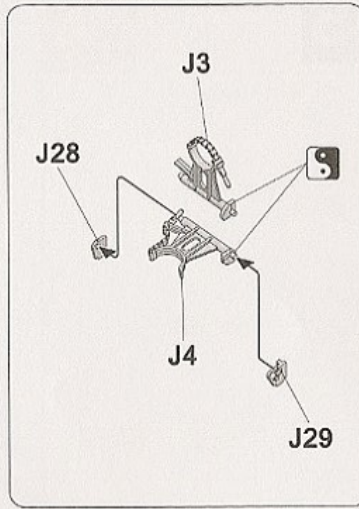
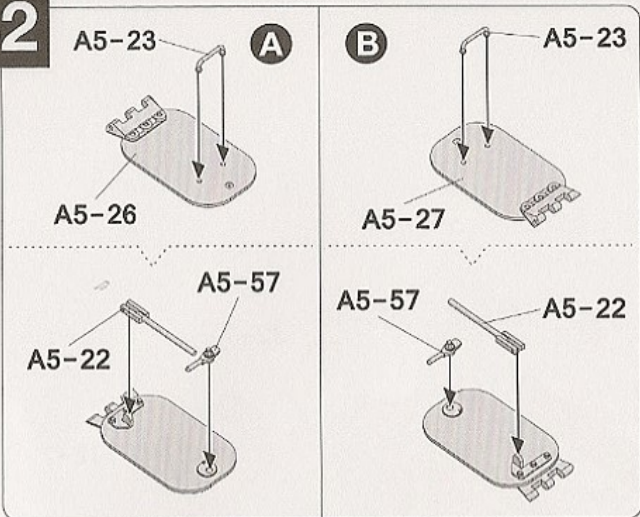



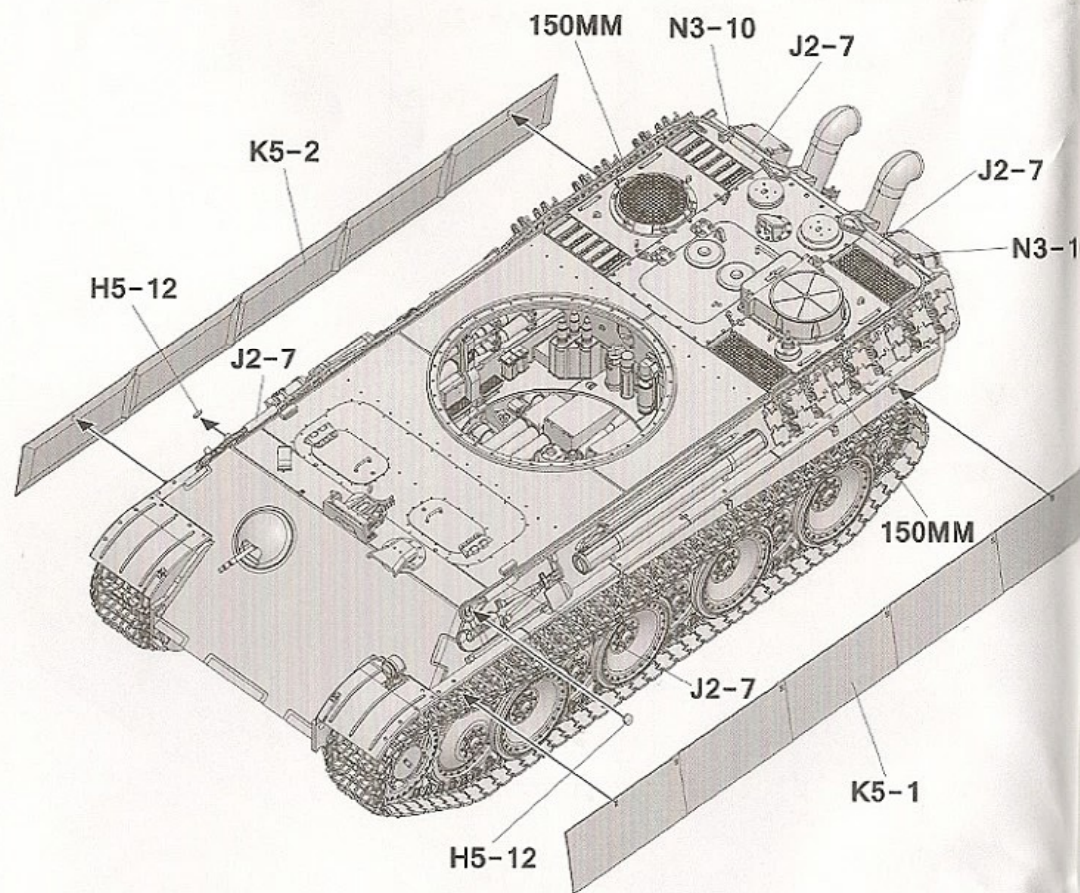
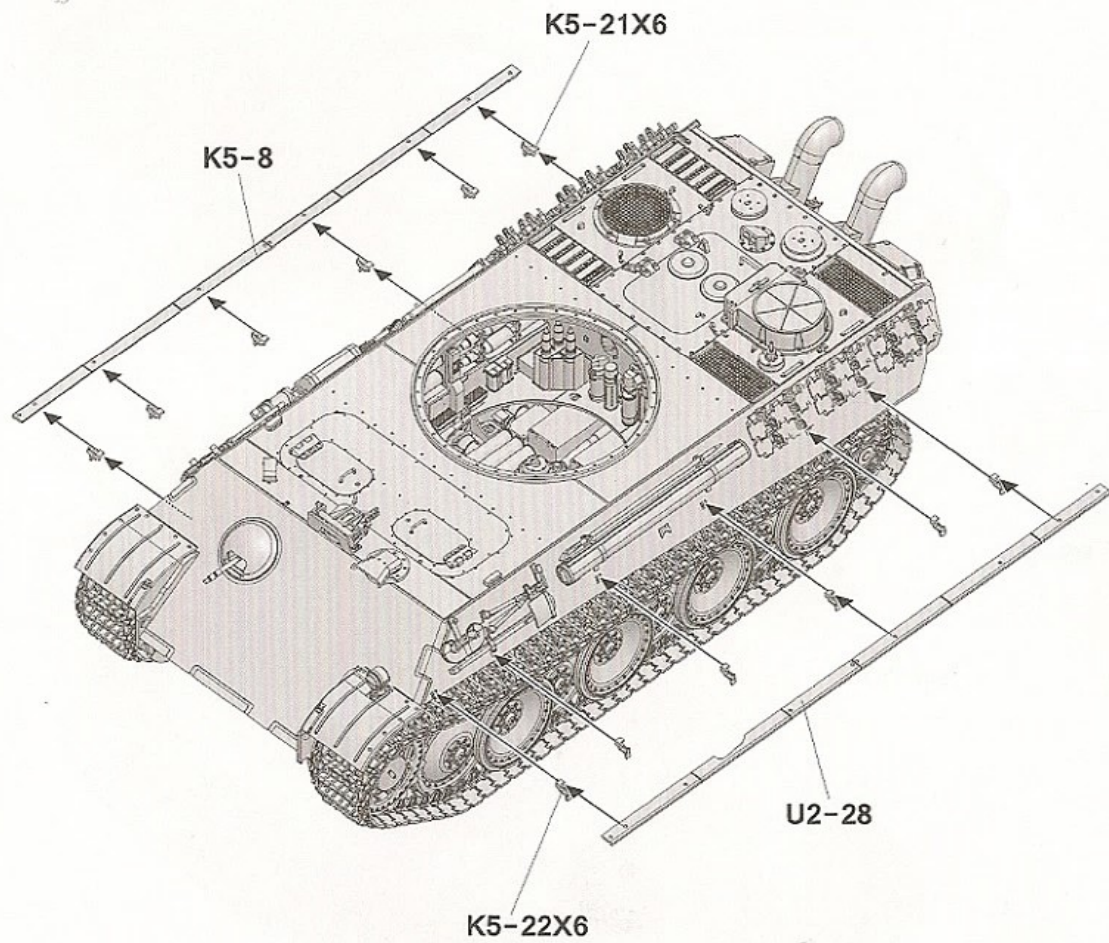



46

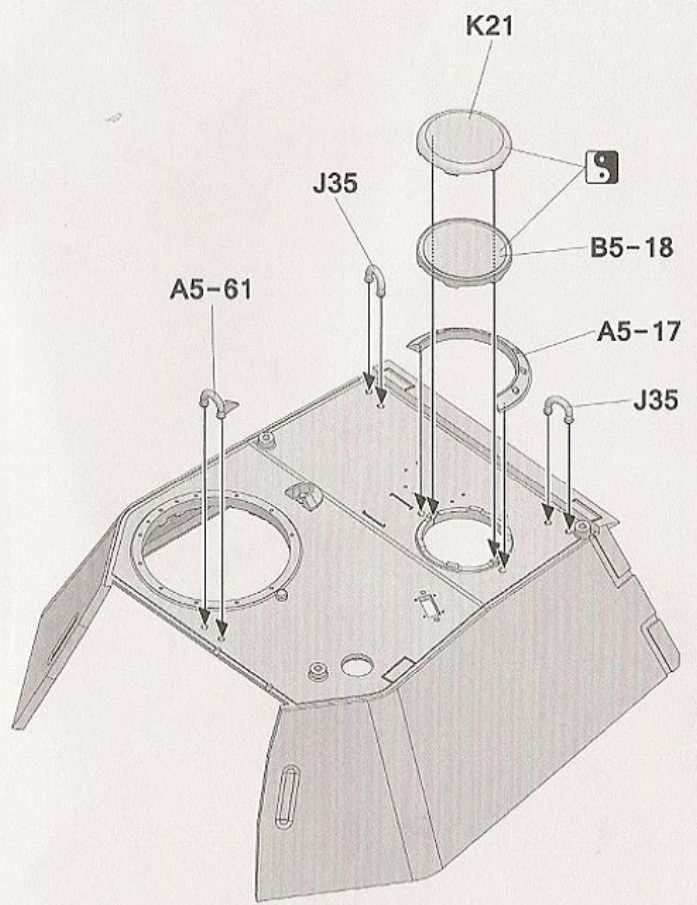

47

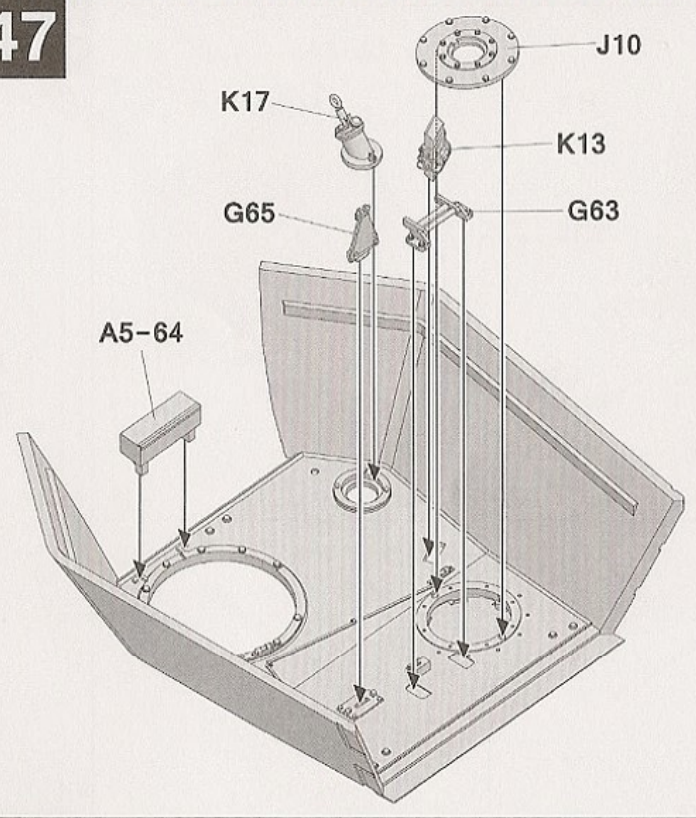

48

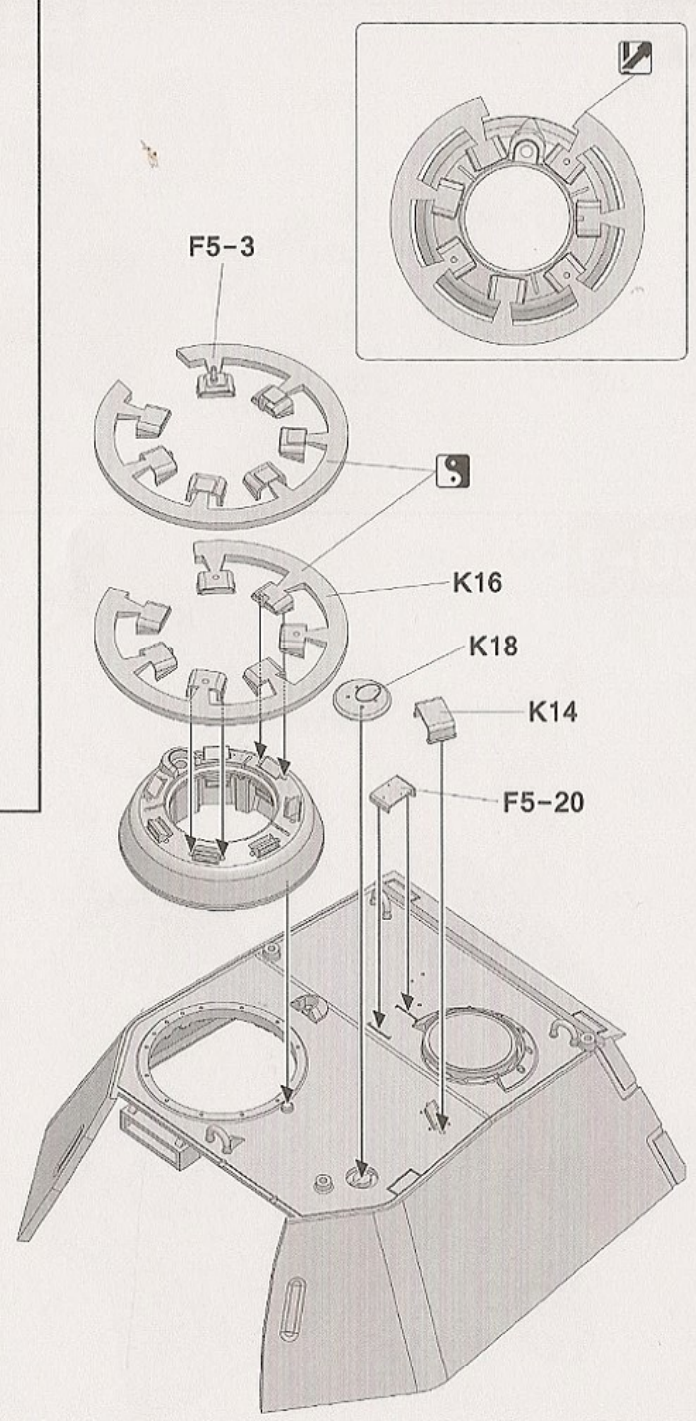
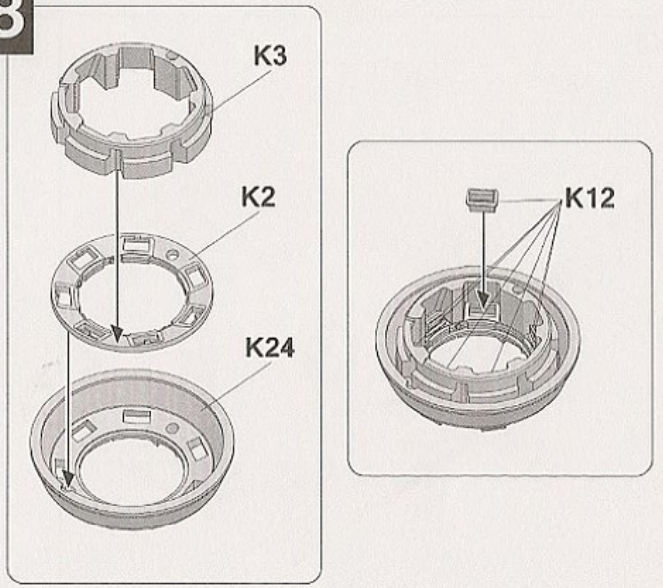



49

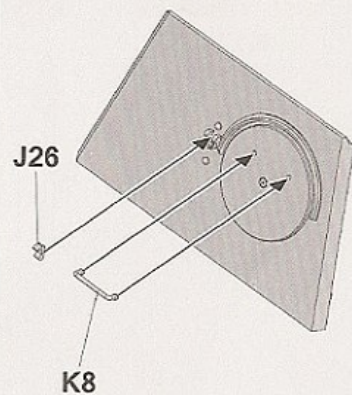
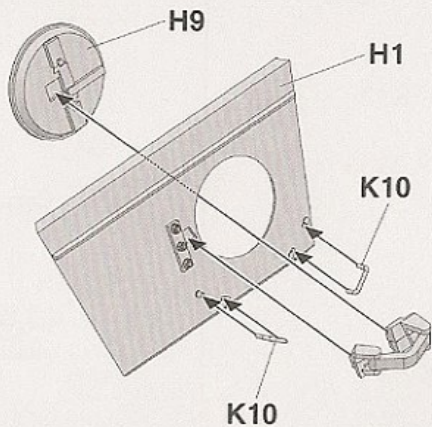
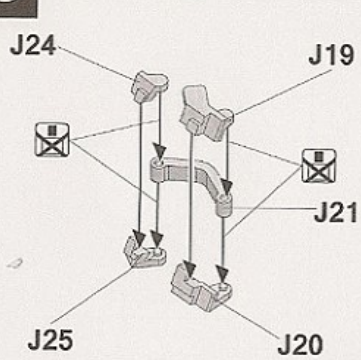

50-2

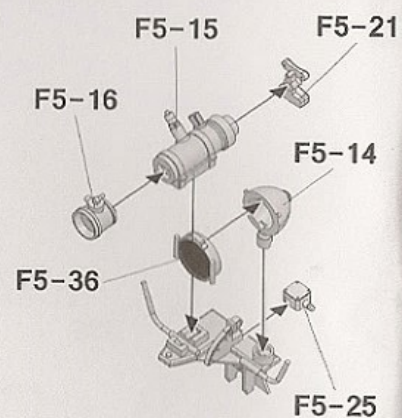
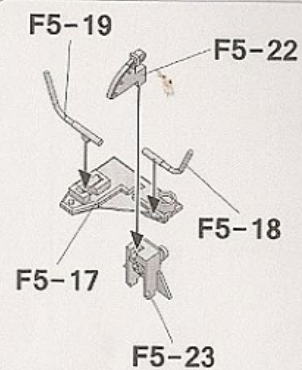

50-1

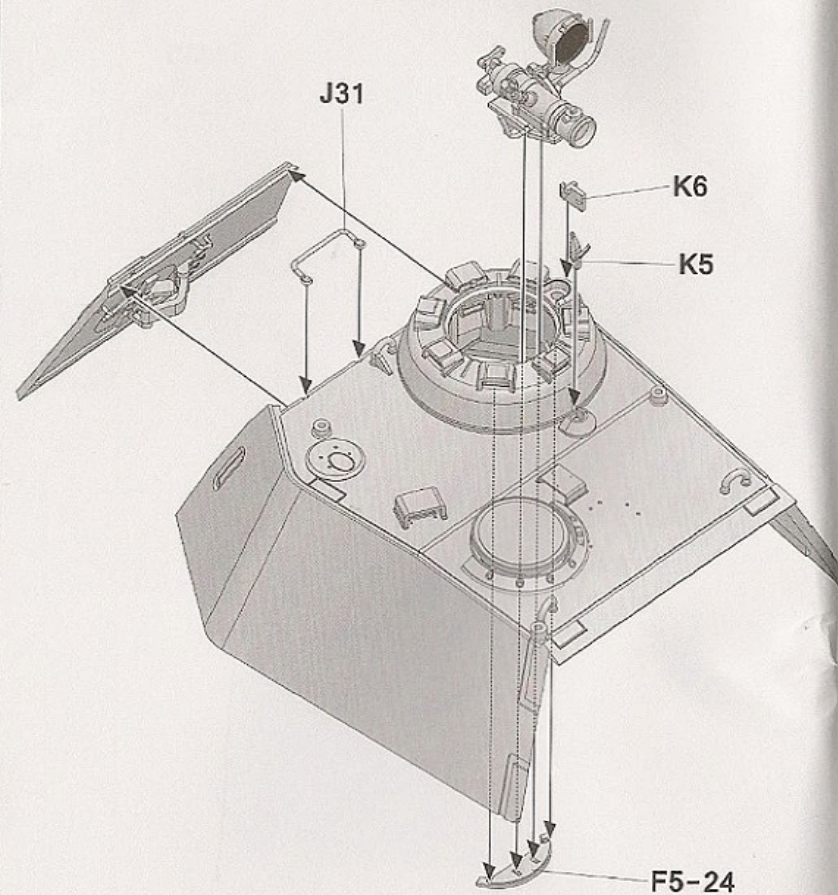
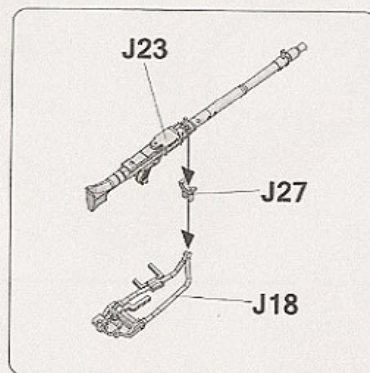
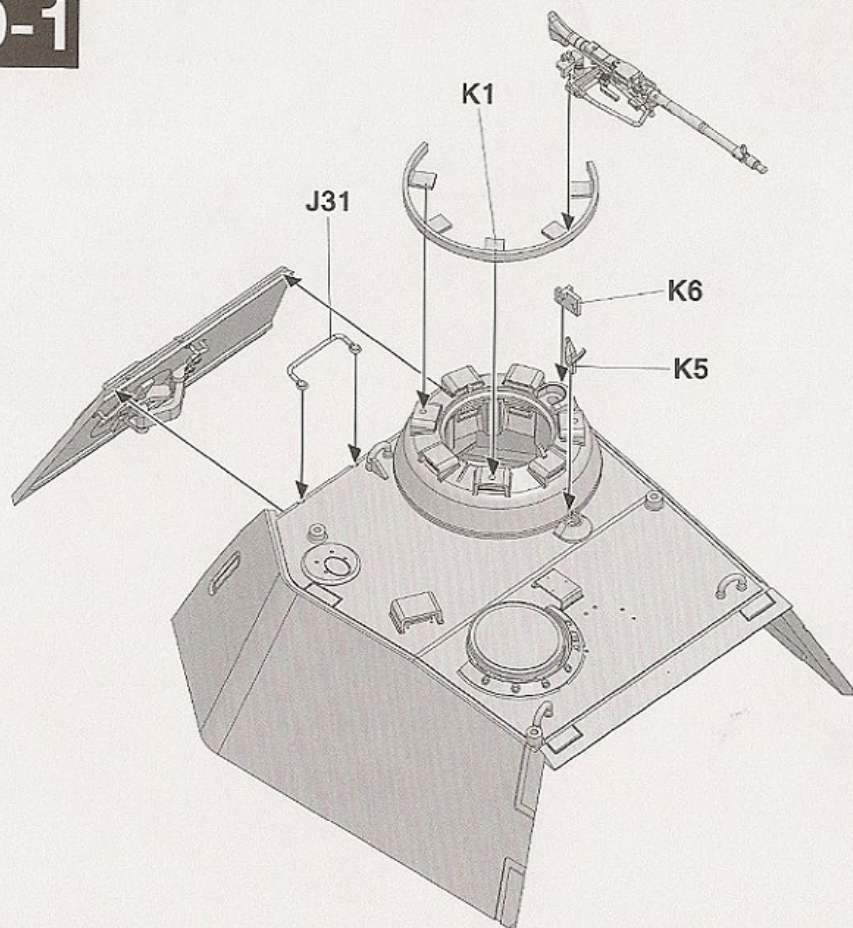



51

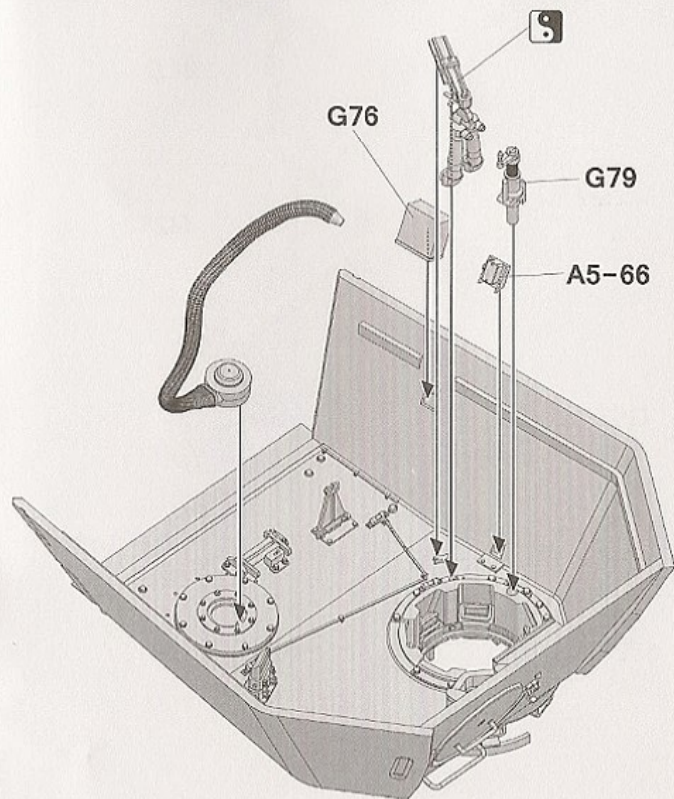
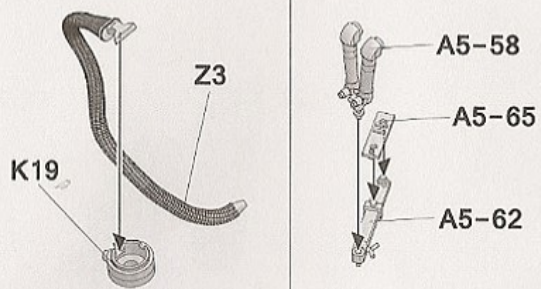

52

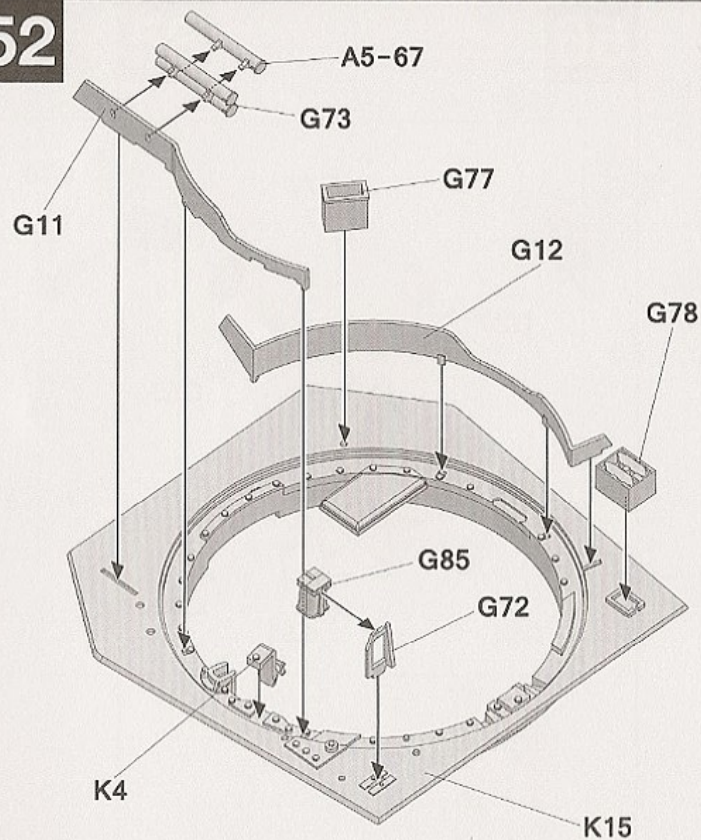

53

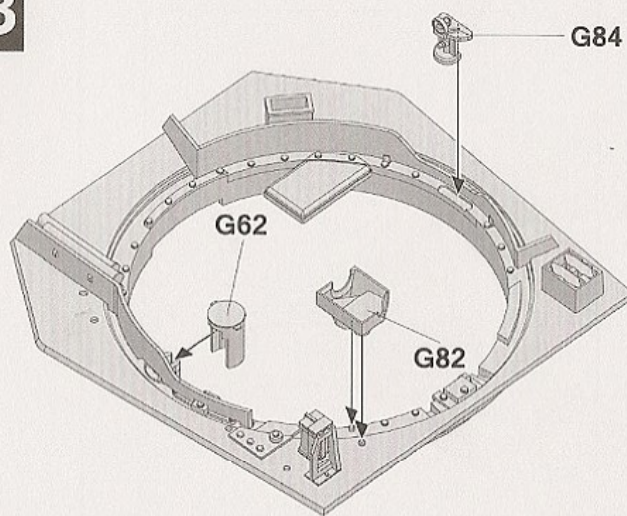

54

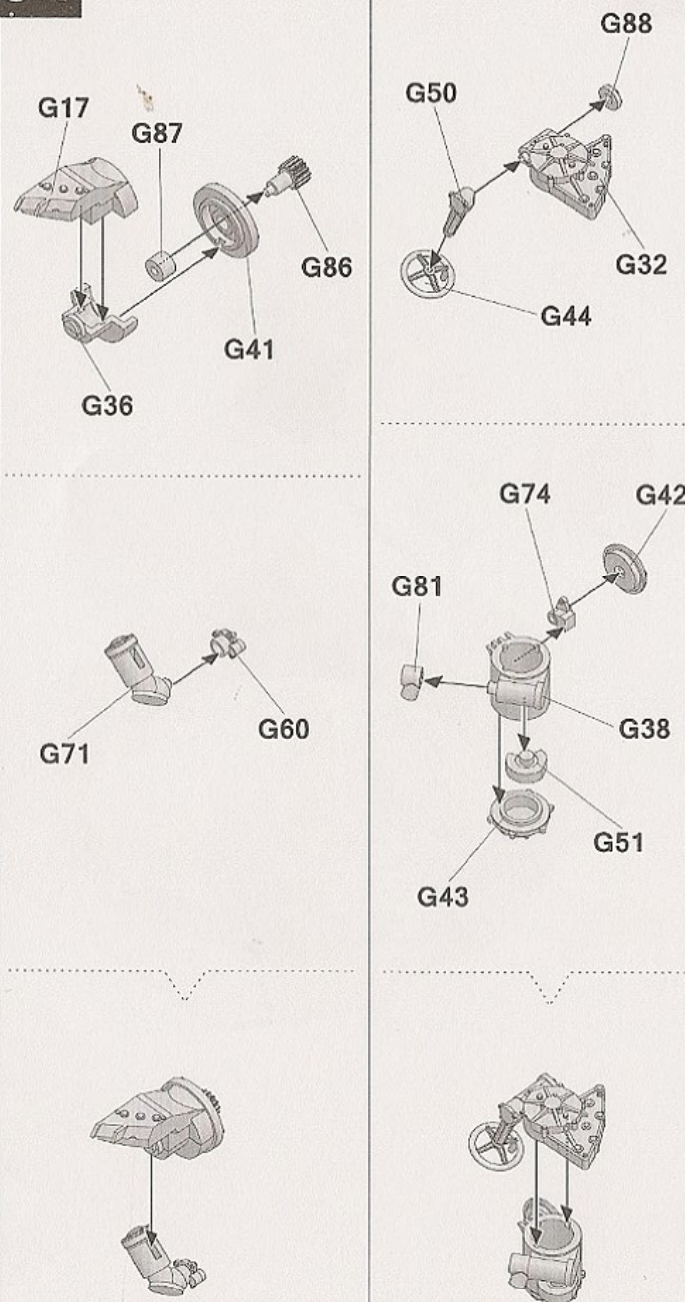



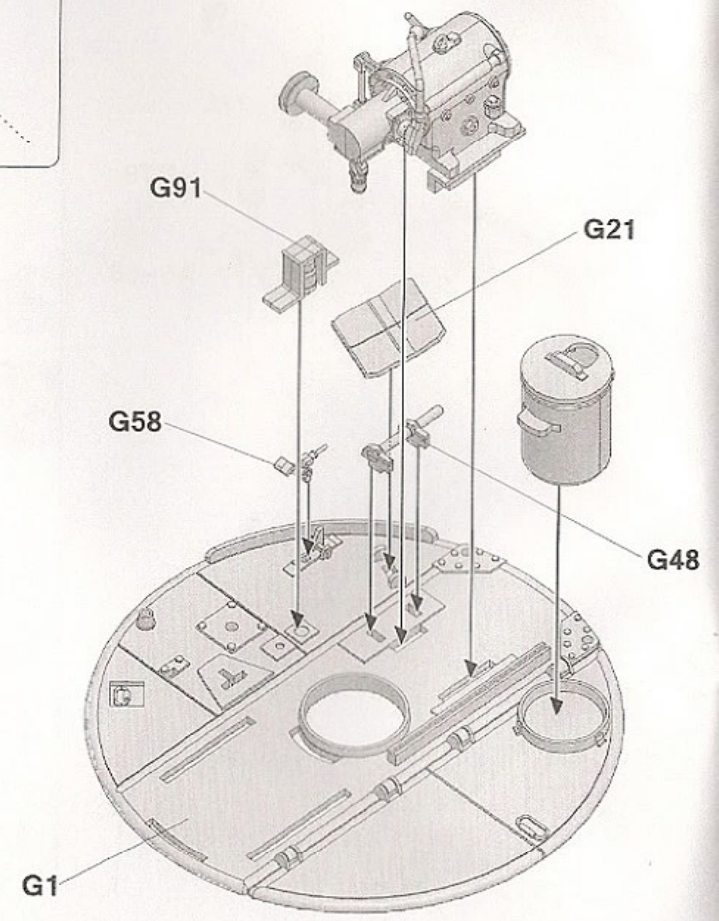
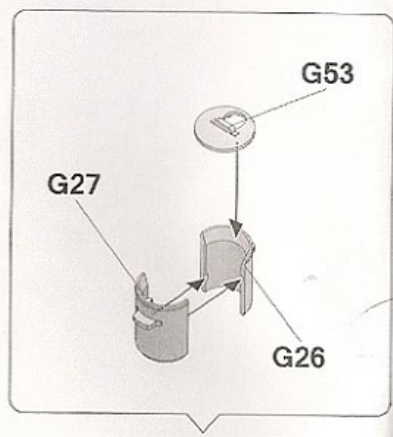
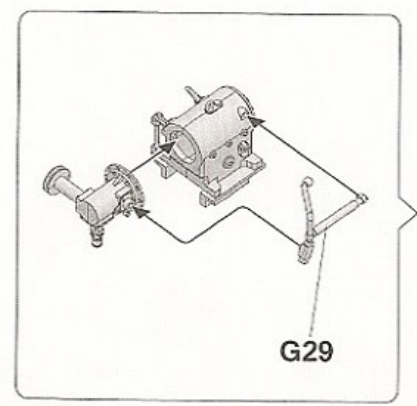
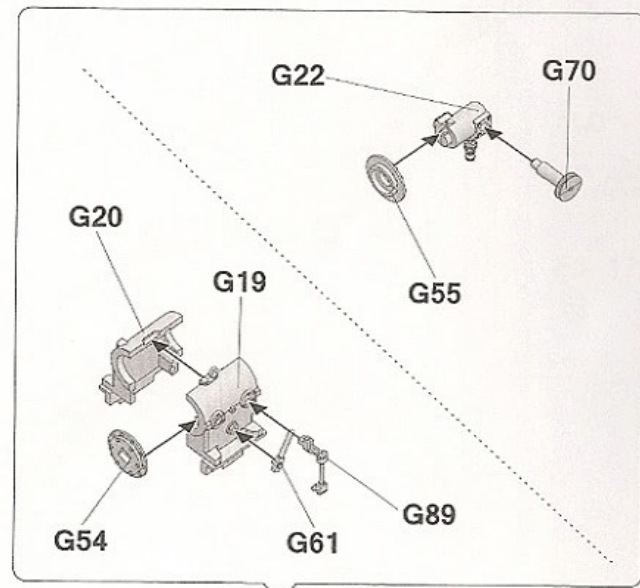
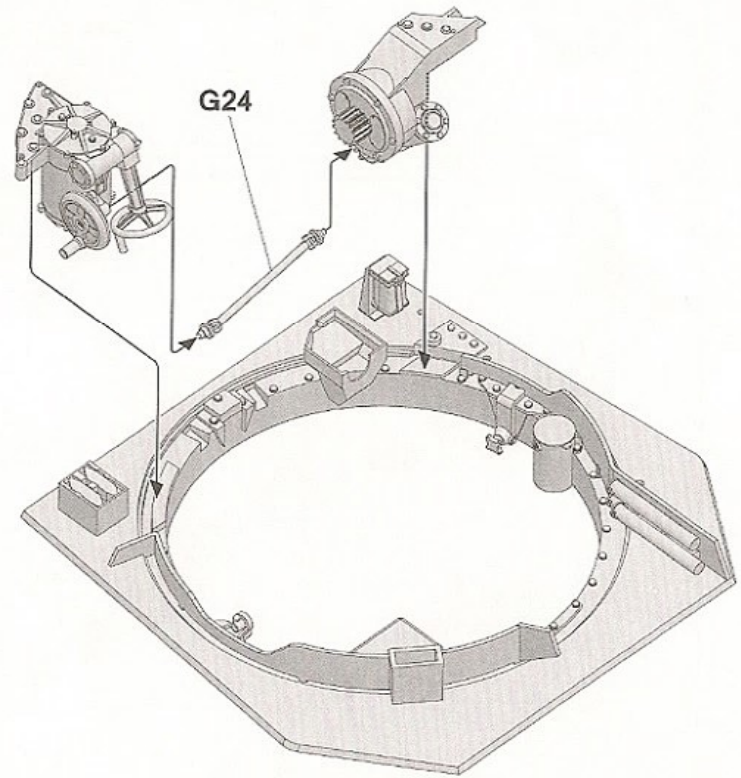



57

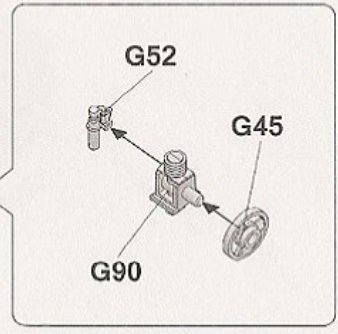
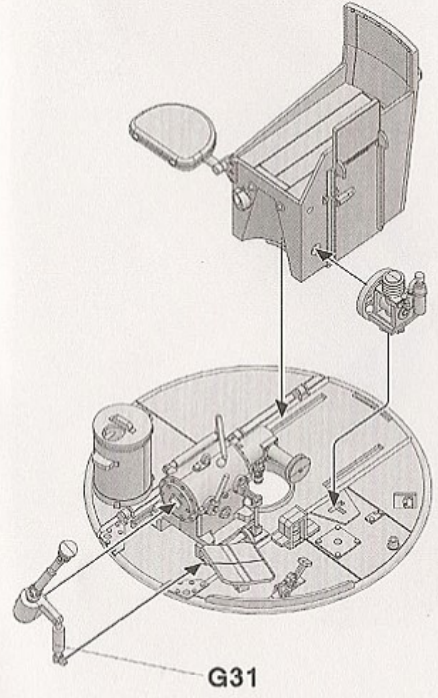
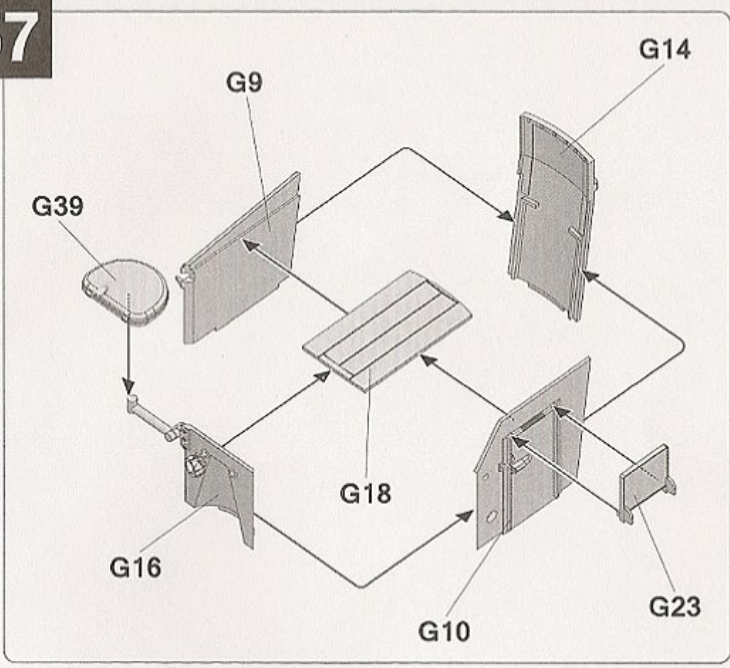

58

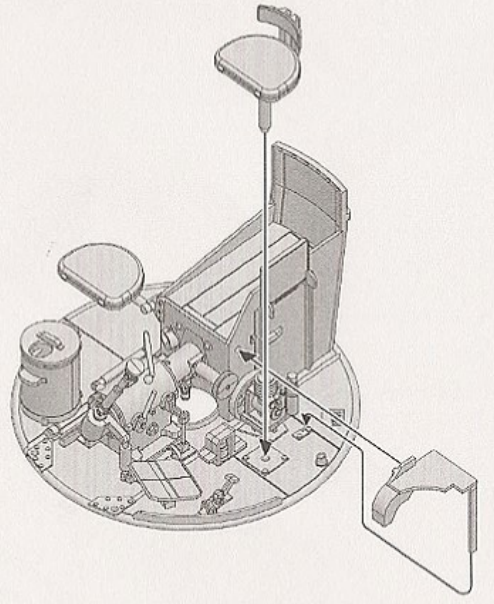
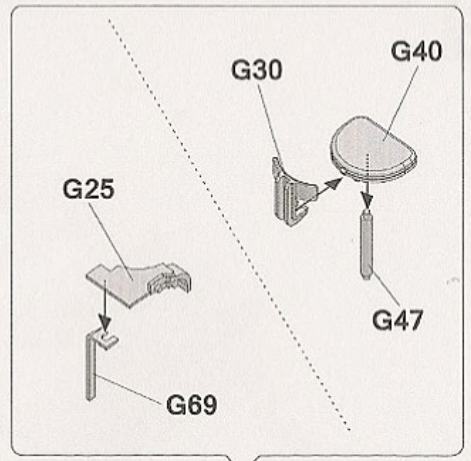
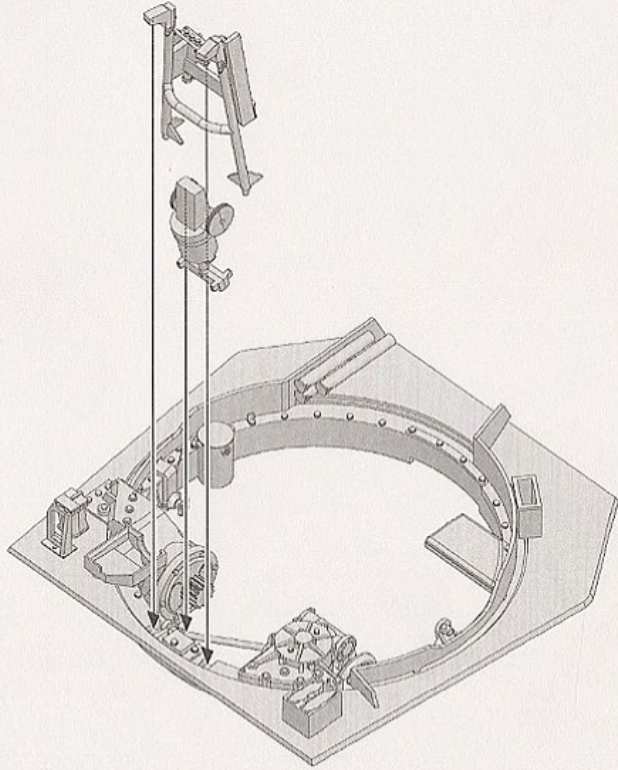
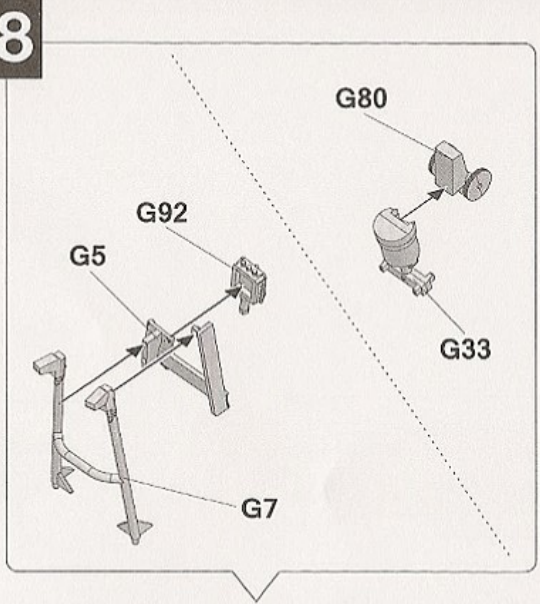



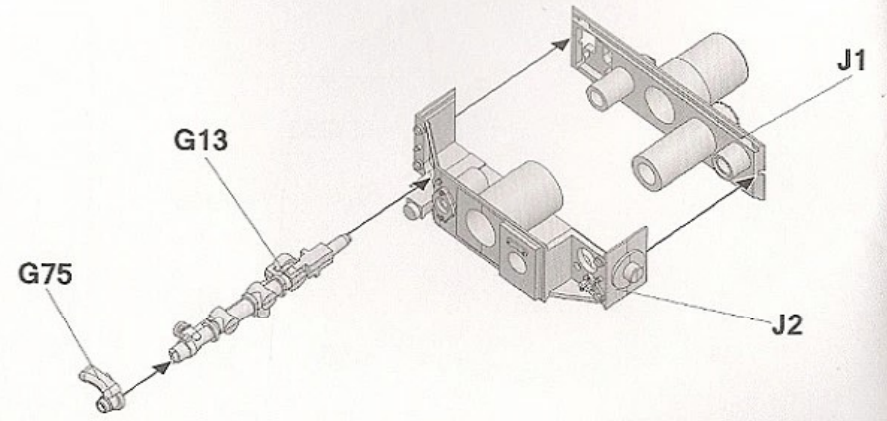
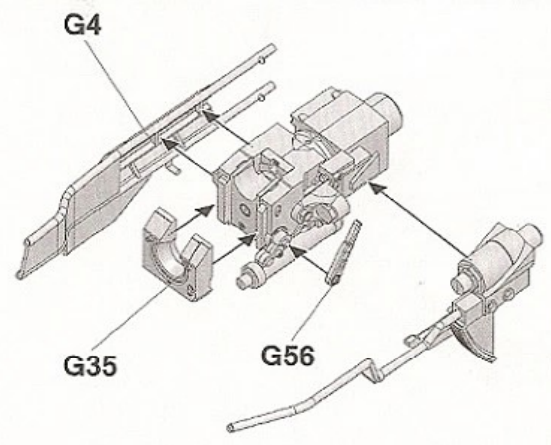
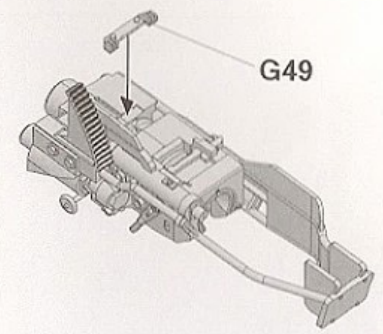
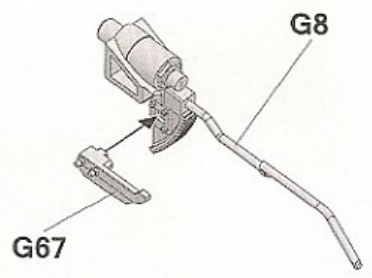
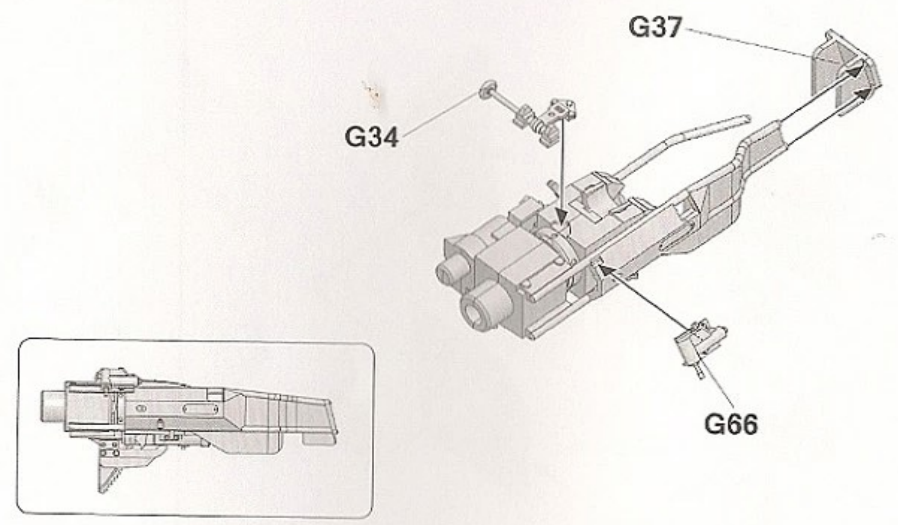
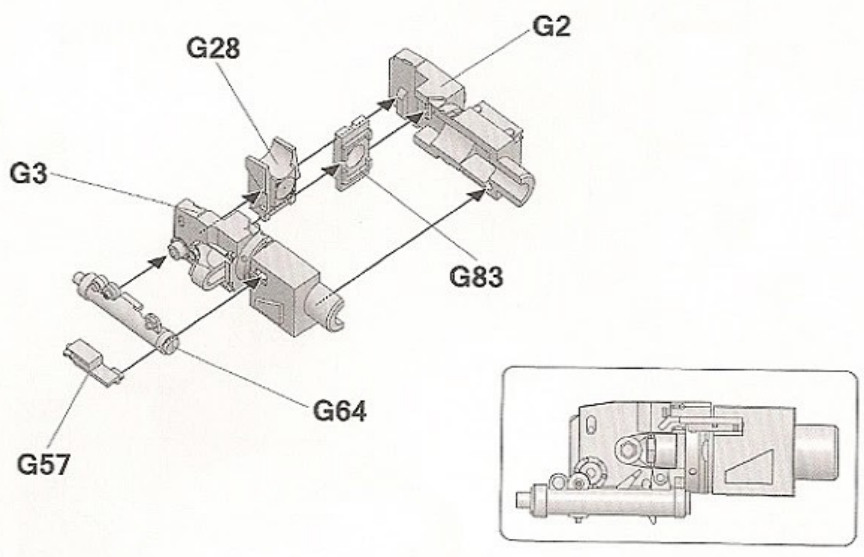



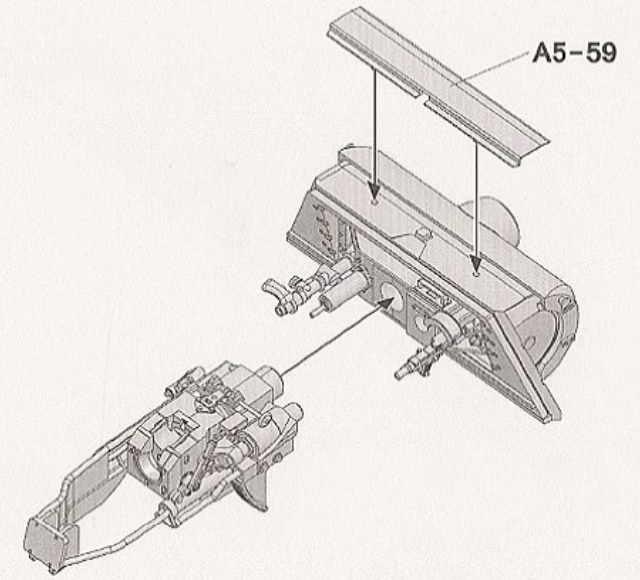
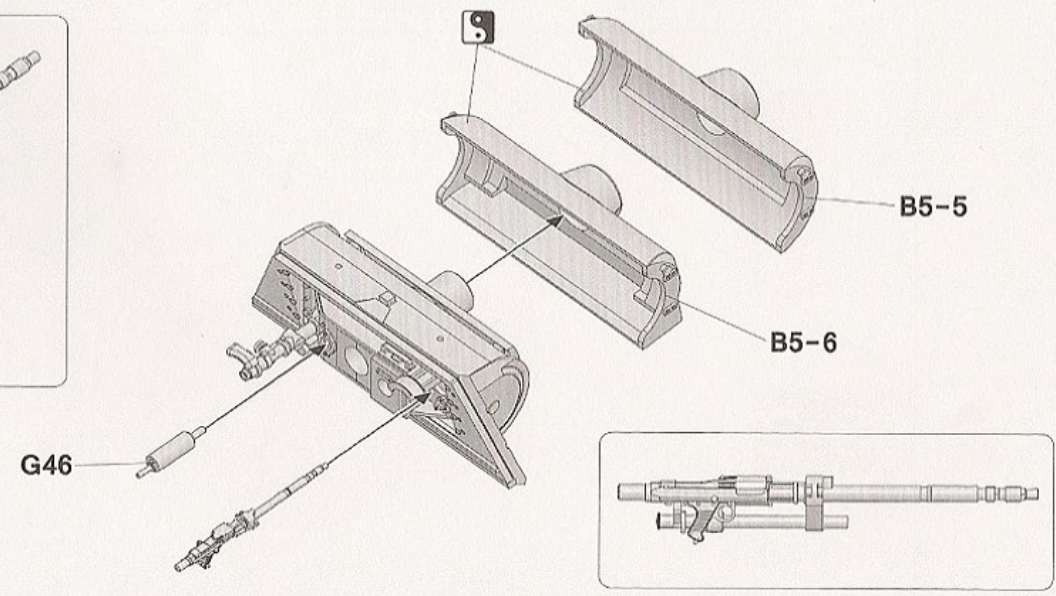
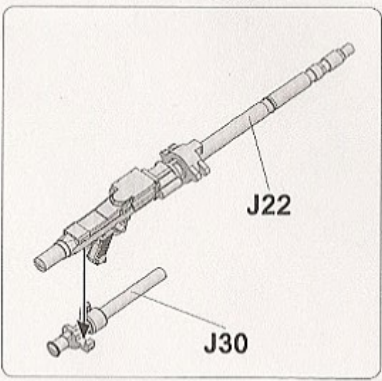
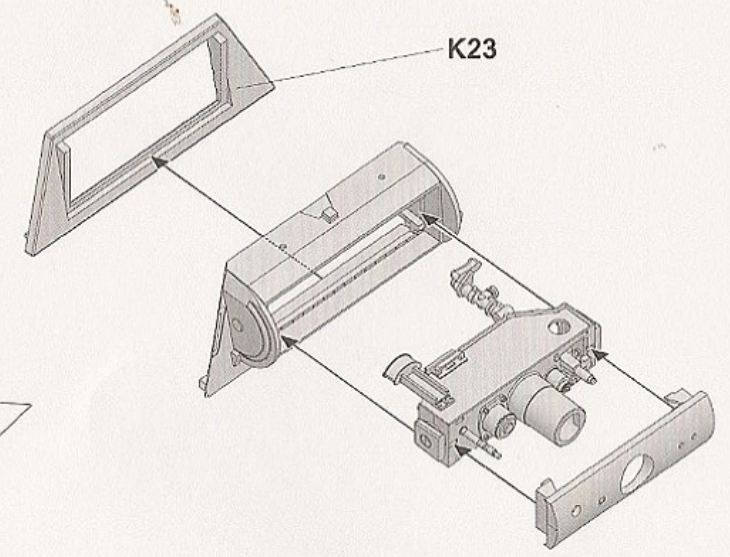
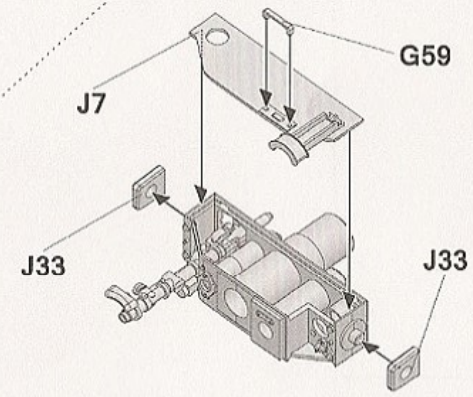
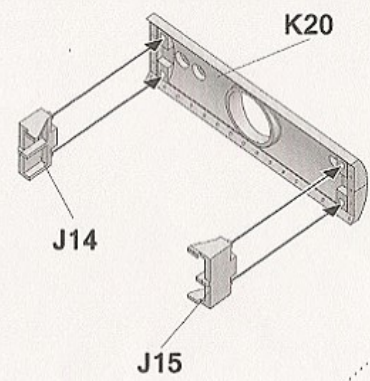
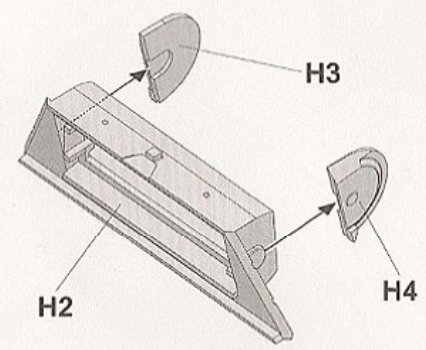
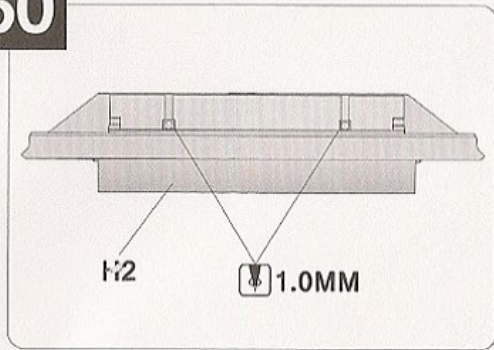



61

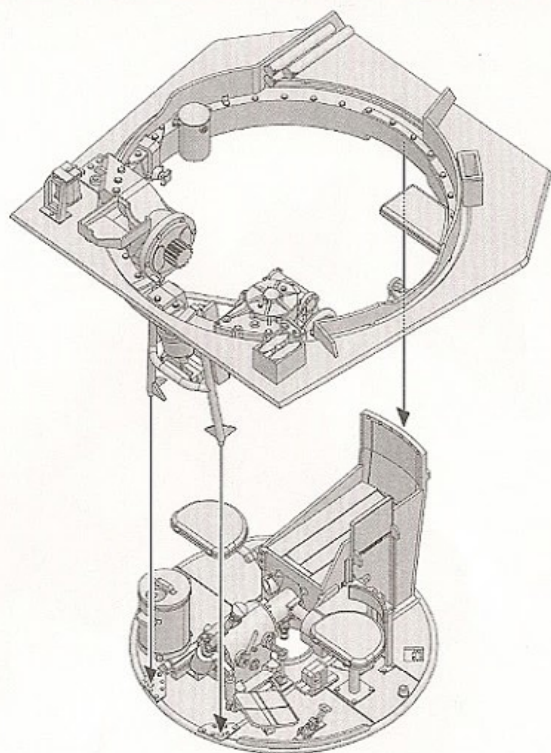

63-1

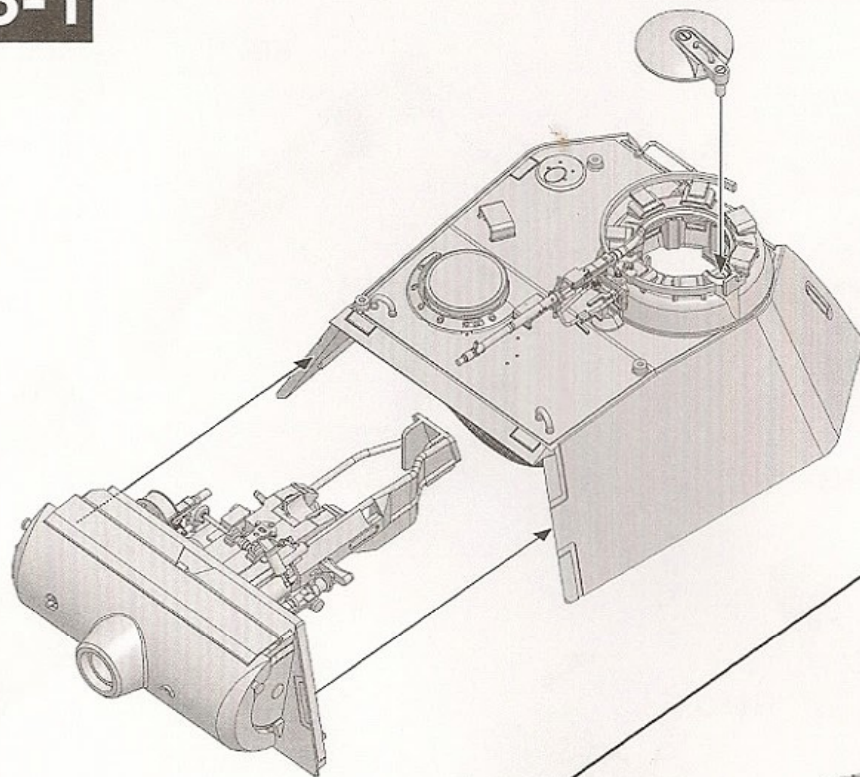

62

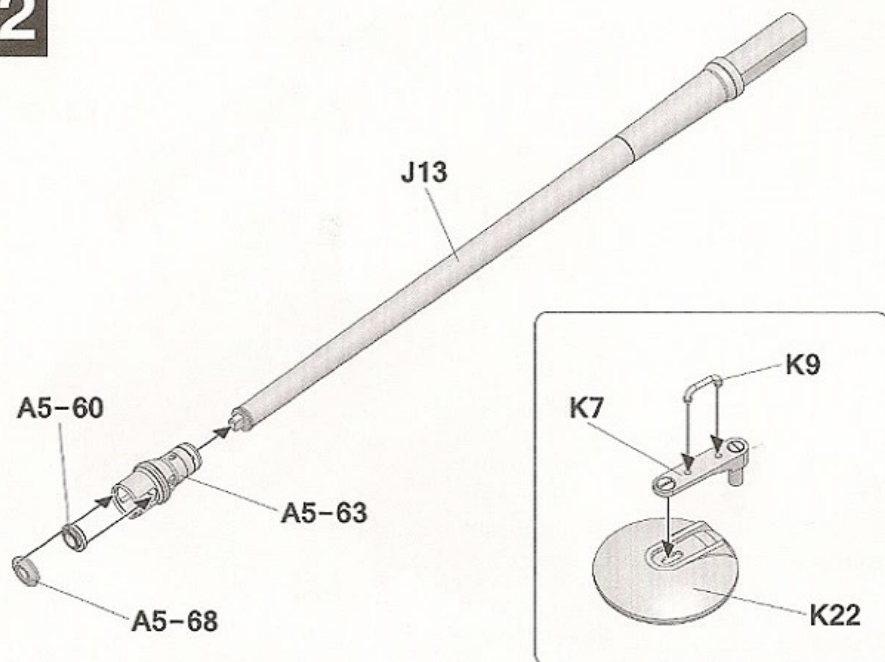

63-2

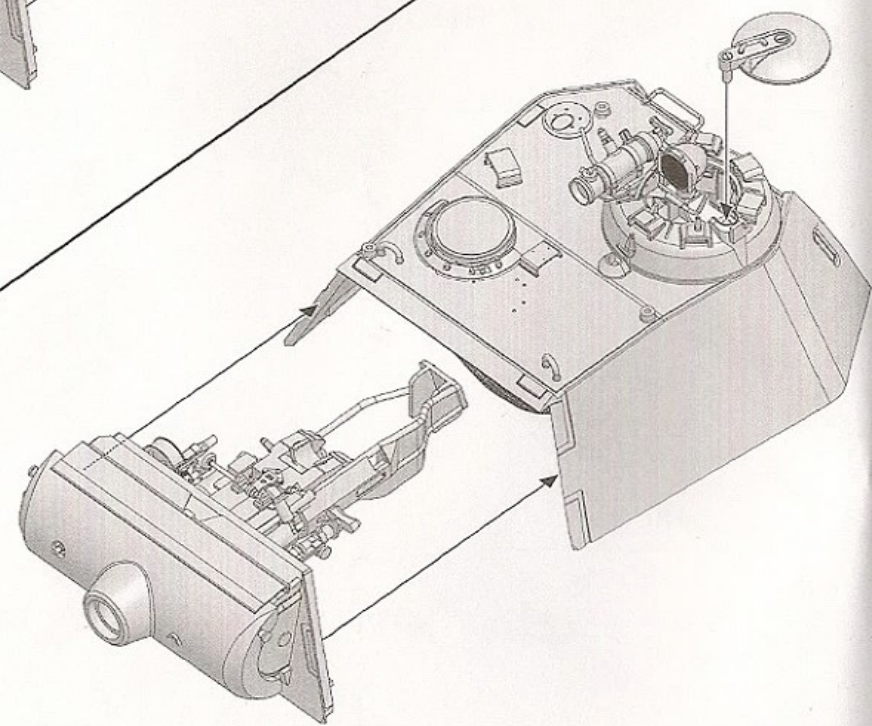



# 64-1

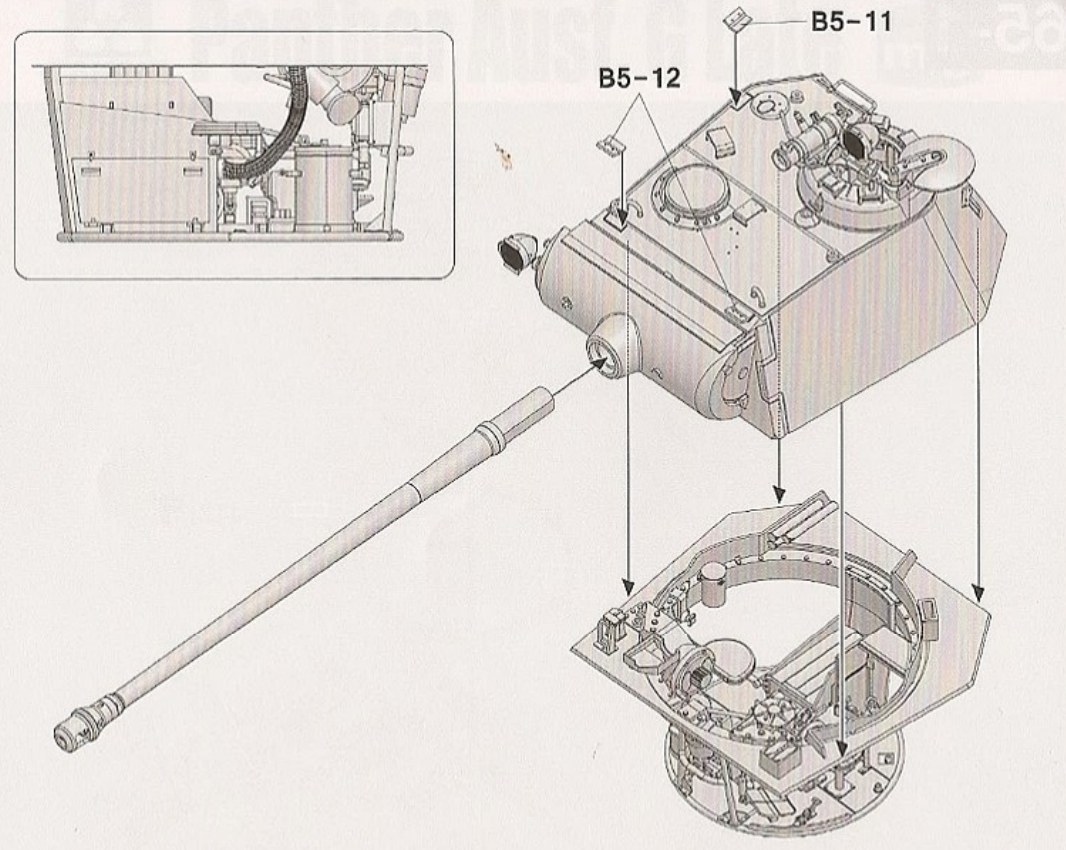
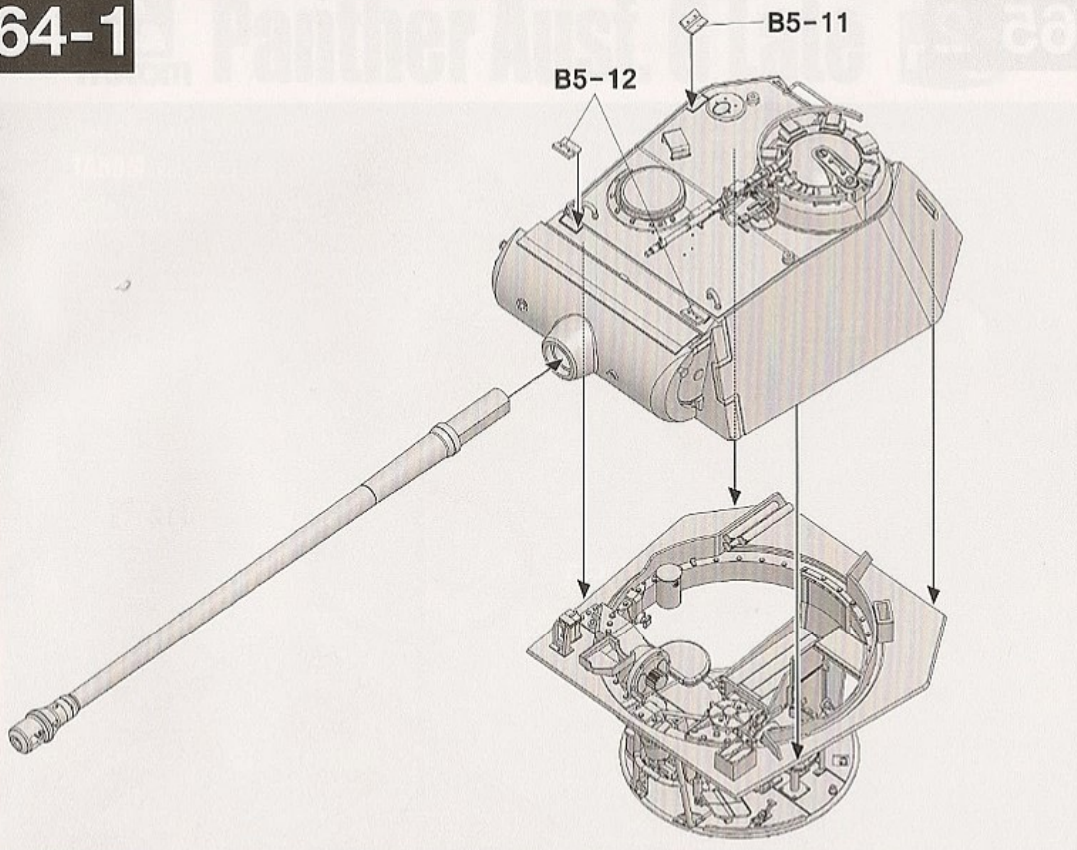

# 64-2

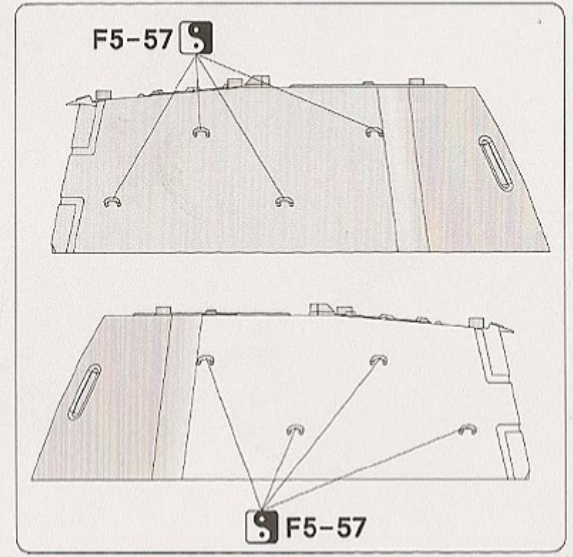
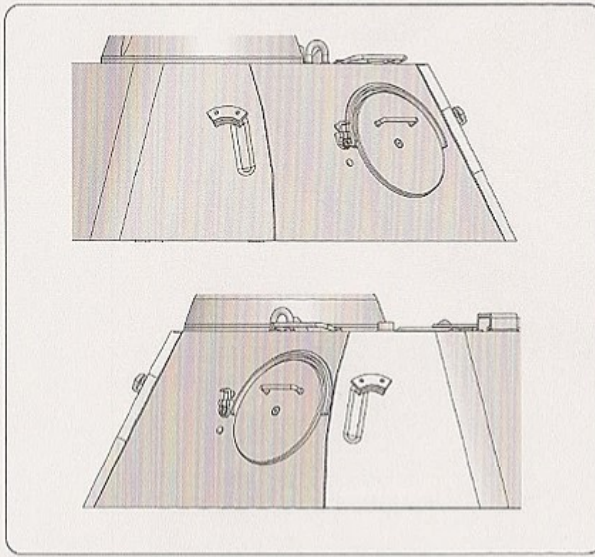
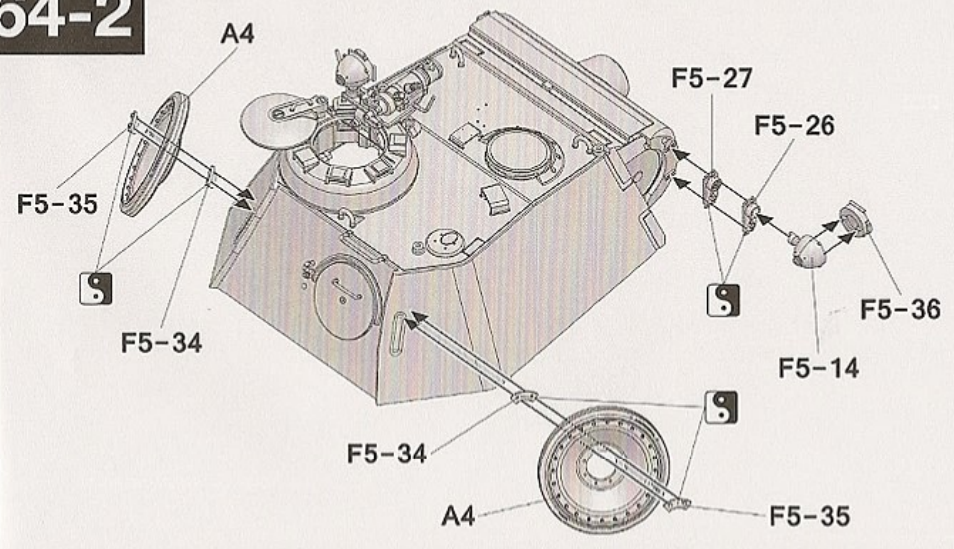



65-1

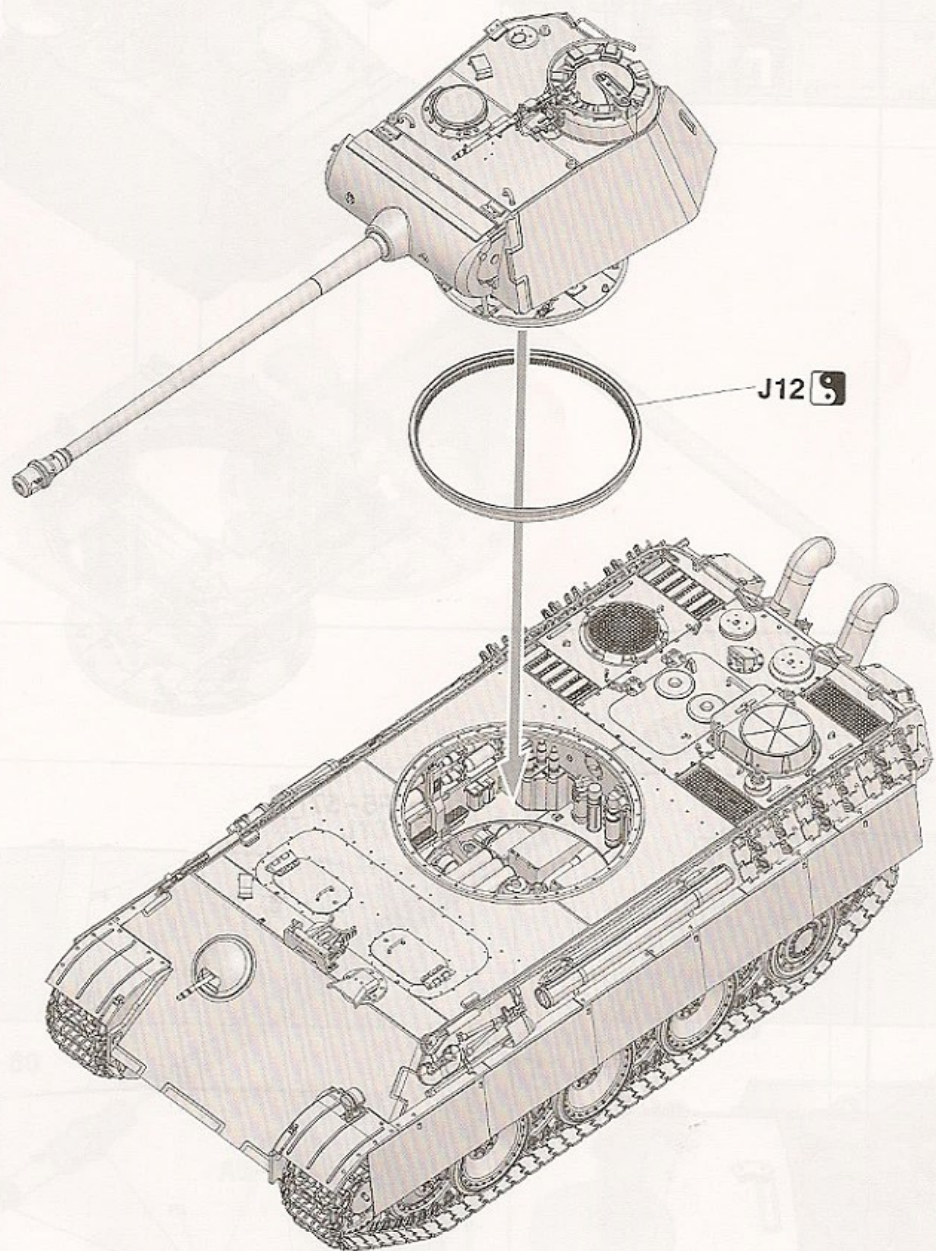

65-2

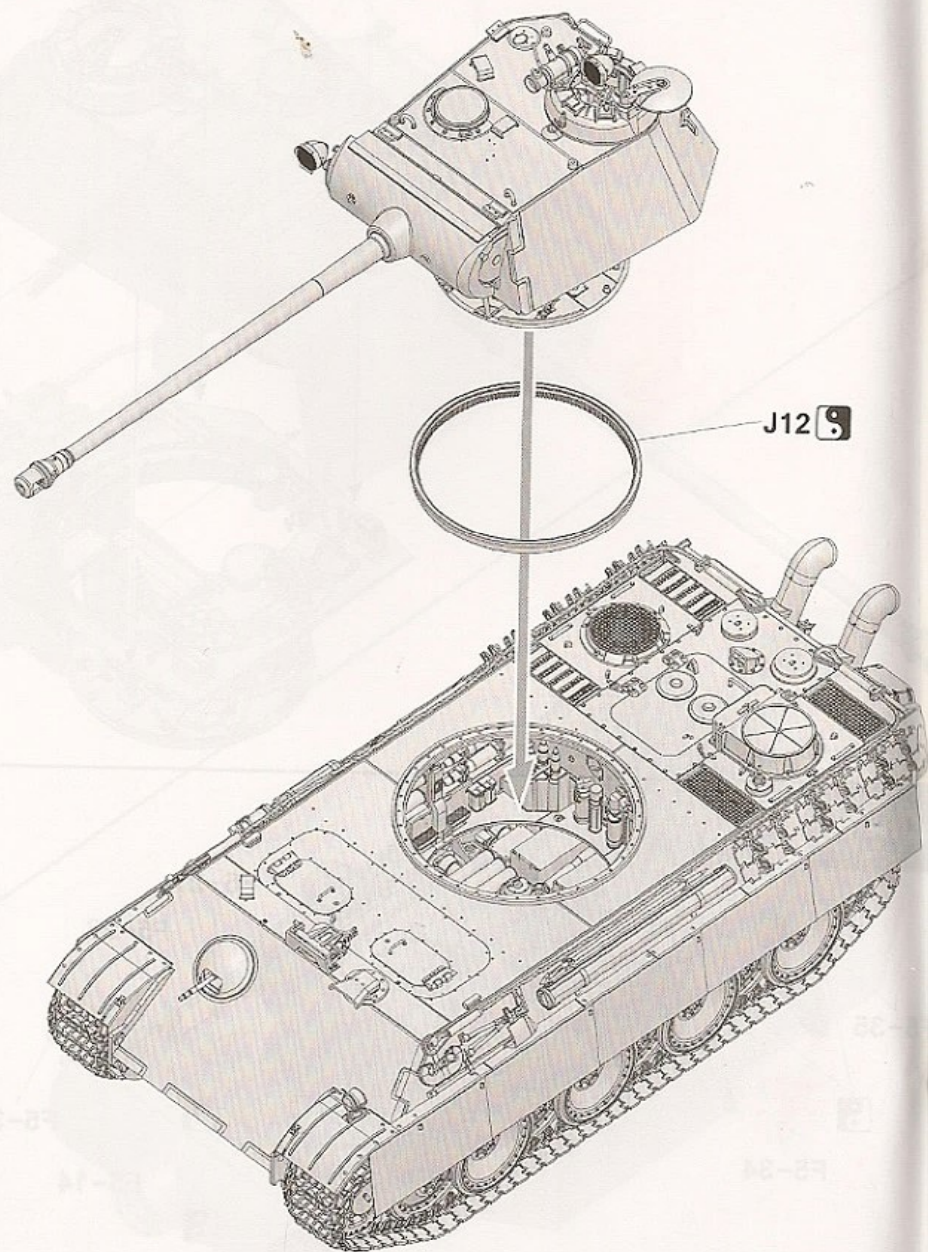



## Painting and Marking Guide

**TAKOM** Ref: 2121

Panther Ausf. G Late Production with full interior.

I./Panzer Brigade 29,  
Panzer Division 'Muncheberg',  
Berlin, Germany, April 1945

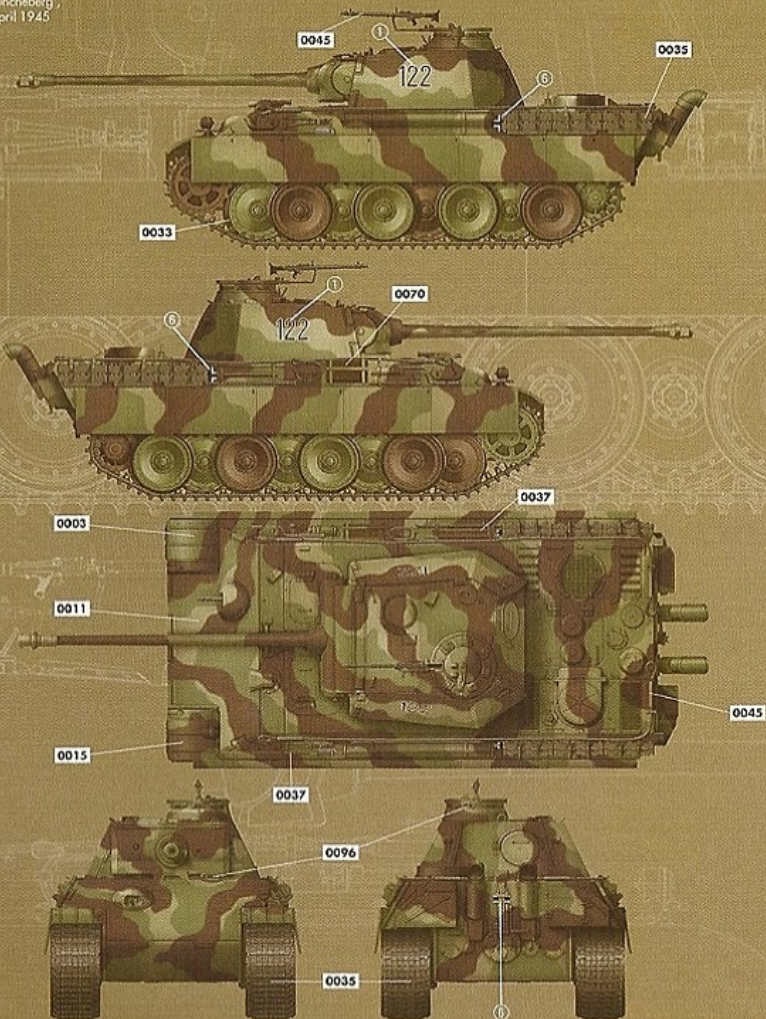

### WEATHERING STEPS WITH AMMO PRODUCTS

- |   |  |   |   |
|---|--|---|---|
| <b>1 GENERAL WASH</b><br>A.MIG-1006 Dark Brown Wash for Green | <b>3 STREAKING</b><br>A.MIG-1203 Streaking Grime | <b>5 RUST</b><br>A.MIG-1254 Streakingbrusher Rust | <b>7 MUD &amp; SPLASHES</b><br>A.MIG-1705 Wet Mud / A.MIG-1754 Damp Earth |
| <b>2 FILTER</b><br>A.MIG-1510 Tin for 3 Tone Camo             | <b>4 TRACK WASH</b><br>A.MIG-1002 Tracks Wash    | <b>6 DUST</b><br>A.MIG-3028 City Dark Dust        | <b>8 GREASE &amp; OIL</b><br>A.MIG-1408 Fresh Engine Oil                  |

## Painting and Marking Guide

**TAKOM** Ref: 2121

Panther Ausf. G Late Production with full interior.

Kampfgruppe Schulze, Bückeburg / Paderborn,  
Germany, April 1945

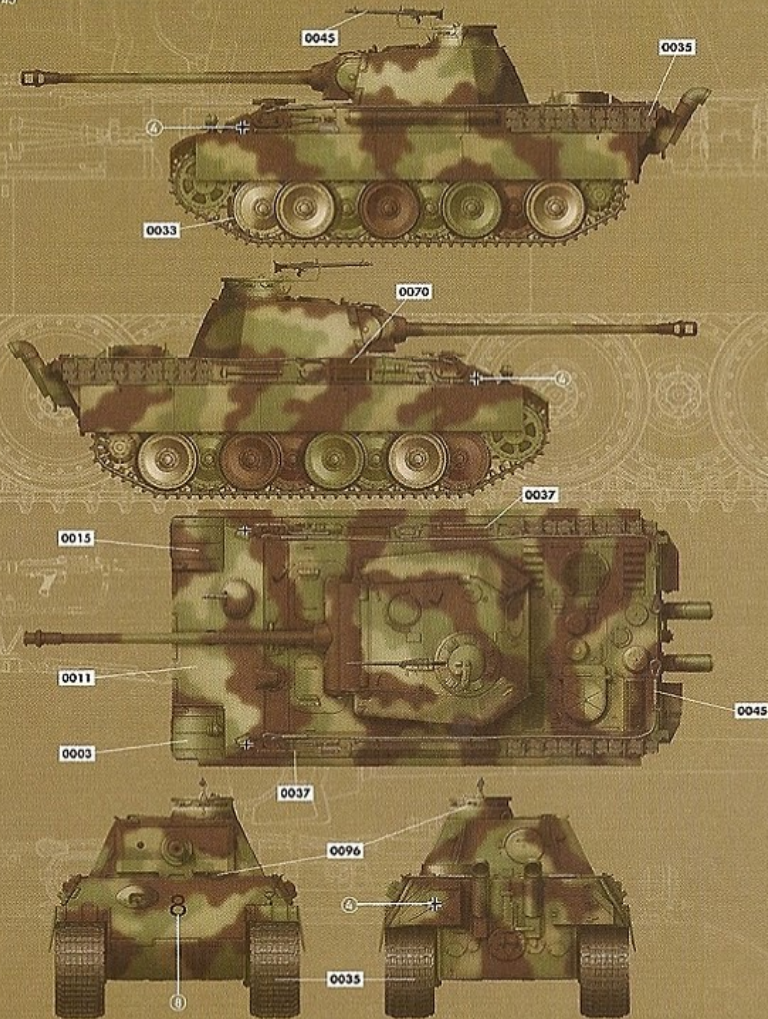

### WEATHERING STEPS WITH AMMO PRODUCTS

- |   |  |   |   |
|---|--|---|---|
| <b>1 GENERAL WASH</b><br>A.MIG-1006 Dark Brown Wash for Green | <b>3 STREAKING</b><br>A.MIG-1203 Streaking Grime | <b>5 RUST</b><br>A.MIG-1254 Streakingbrusher Rust | <b>7 MUD &amp; SPLASHES</b><br>A.MIG-1705 Wet Mud / A.MIG-1754 Damp Earth |
| <b>2 FILTER</b><br>A.MIG-1510 Tin for 3 Tone Camo             | <b>4 TRACK WASH</b><br>A.MIG-1002 Tracks Wash    | <b>6 DUST</b><br>A.MIG-3028 City Dark Dust        | <b>8 GREASE &amp; OIL</b><br>A.MIG-1408 Fresh Engine Oil                  |



# Panther Ausf. G Late



## Painting and Marking Guide

**TAKOM** Ref. 2121

Panther Ausf. G Late Production with full interior.

I./Panzer Regiment 29, Panzer Division 'Muncheberg', Berlin, Germany, May 1945

- |                                |                                |  |                               |
|--------------------------------|--------------------------------|--|-------------------------------|
| <b>AMMO-0033</b> Rubber & Tire | <b>AMMO-0035</b> Dark Tracks   | <b>AMMO-0037</b> New Wood                | <b>AMMO-0070</b> Medium Brown |
| <b>AMMO-0045</b> Gun Metal     | <b>AMMO-0095</b> Crystal Smoke | <b>AMMO-0090</b> Crystal Paraspine Green | <b>AMMO-0008</b> Dunkelgrau   |
| <b>AMMO-0018</b> Gelbbraun     | <b>AMMO-0015</b> Schokobraun   | <b>AMMO-0003</b> Seesandgrün             |                               |

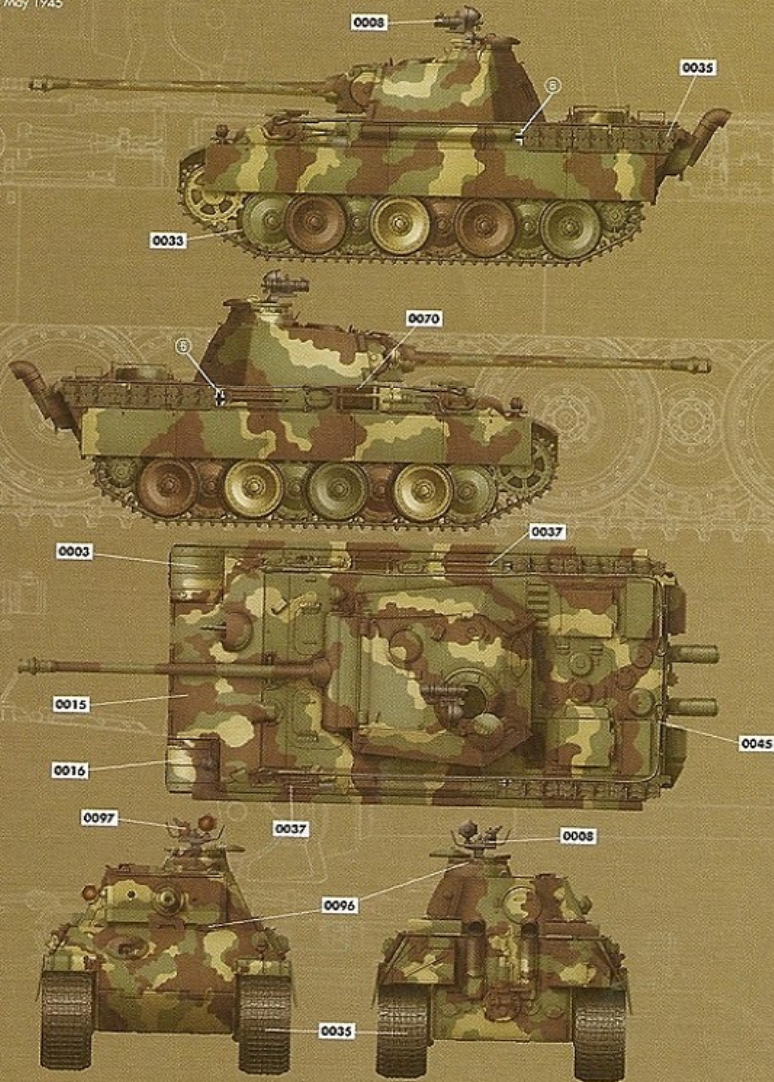

### WEATHERING STEPS WITH AMMO PRODUCTS

- |   |  |  |   |
|---|--|--|---|
| <b>1 GENERAL WASH</b><br>A.MIG-1005 Dark Brown Wash for Green | <b>3 STREAKING</b><br>A.MIG-1203 Streaking Grime | <b>5 RUST</b><br>A.MIG-1254 Streakingbushet Rust | <b>7 MUD &amp; SPLASHES</b><br>A.MIG-1705 Wet Mud / A.MIG-1754 Damp Earth |
| <b>2 FILTER</b><br>A.MIG-1510 Tan for 3 Tone Camo             | <b>4 TRACK WASH</b><br>A.MIG-1002 Tracks Wash    | <b>6 DUST</b><br>A.MIG-3028 City Dark Dust       | <b>8 GREASE &amp; OIL</b><br>A.MIG-1408 Fresh Engine Oil                  |

# PANTHER Ausf. G w/Steel Wheels

## Mid Production 2in1



A DETAILED STATIC DISPLAY PLASTIC MODEL.  
A TRACK ASSEMBLY IS ADDED WITH THE USE OF A JOG.  
A LONG & LENGTH STYLE TRACKS INCLUDED.  
A ALL HATCHES CAN BE BUILT IN OPEN OR CLOSED POSITION.  
A PVC INCLUDED.  
A 9 TYPES OF MARKINGS.



Designed by Alex Studio  
1/35 No.2120  
THIS IS A 2 IN 1 KIT TO ASSEMBLE A PRECISION MODEL KIT.  
A TRACK ASSEMBLY FOR COLLECTORS 100+ YEARS AND ABOVE.  
MODEL MAY VARY FROM REAL CHECK.  
GLUE AND PAINT NOT INCLUDED.

JASON SHIP  
**Full Interior**

# A PANTHER w/ Zimmerit

## MID-LATE Production

54 Kfz 257  
52 Kfz 171 2in1



Designed by Alex Studio  
1/35 No.2121  
THIS IS A 2 IN 1 KIT TO ASSEMBLE A PRECISION MODEL KIT.  
A TRACK ASSEMBLY FOR COLLECTORS 100+ YEARS AND ABOVE.  
MODEL MAY VARY FROM REAL CHECK.  
GLUE AND PAINT NOT INCLUDED.

1/35 No.2121



# Interior Painting

Color info and profiles by

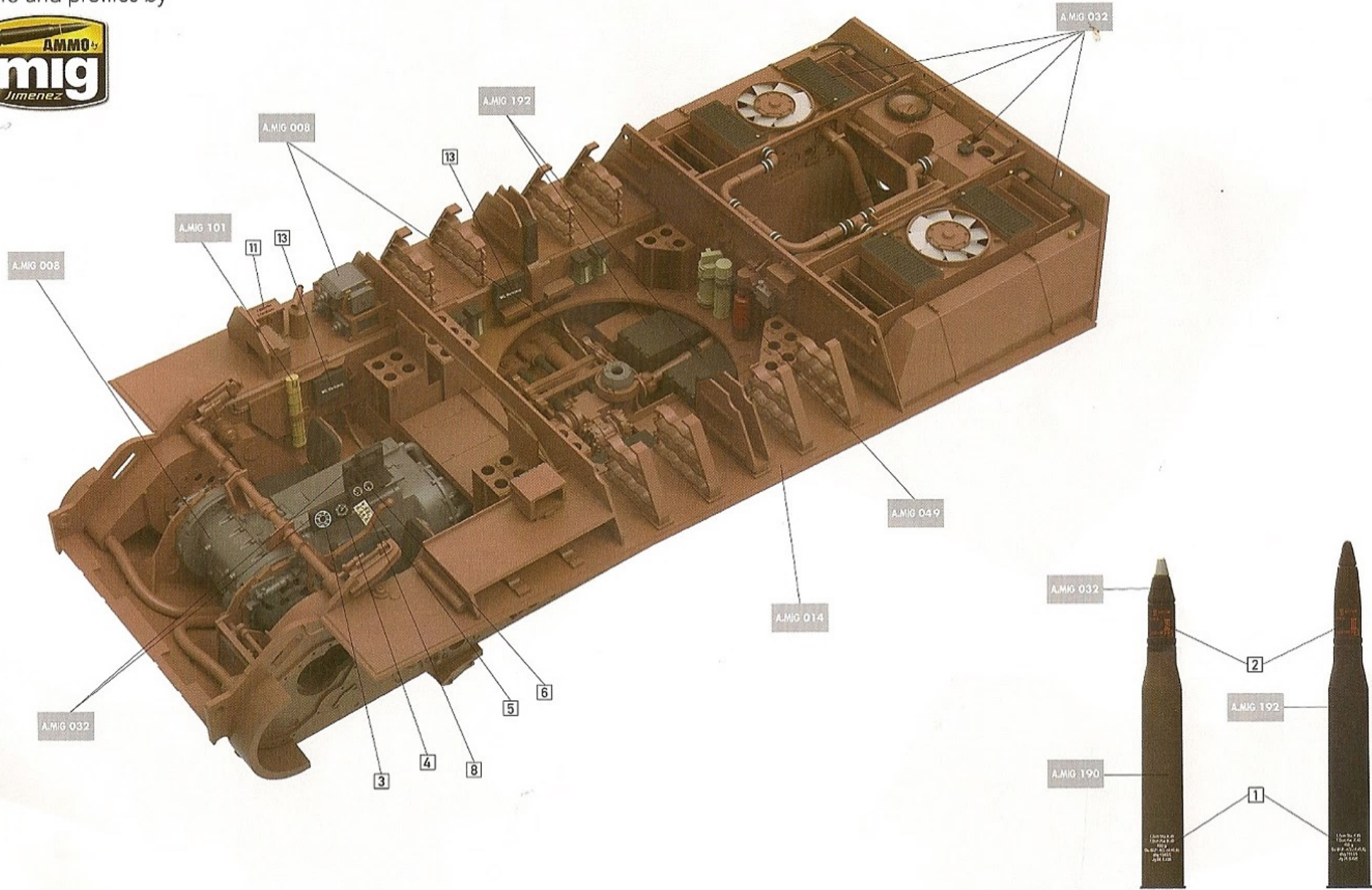



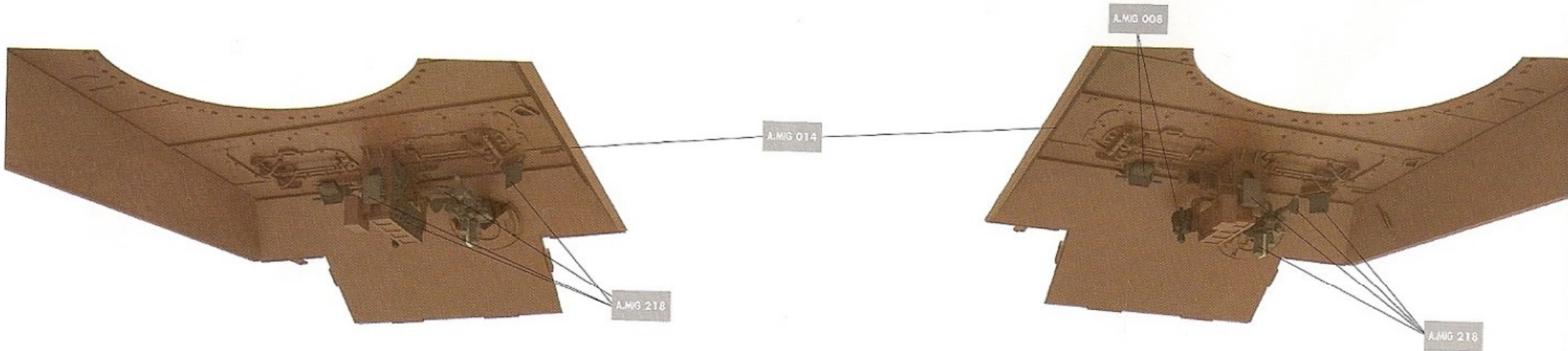
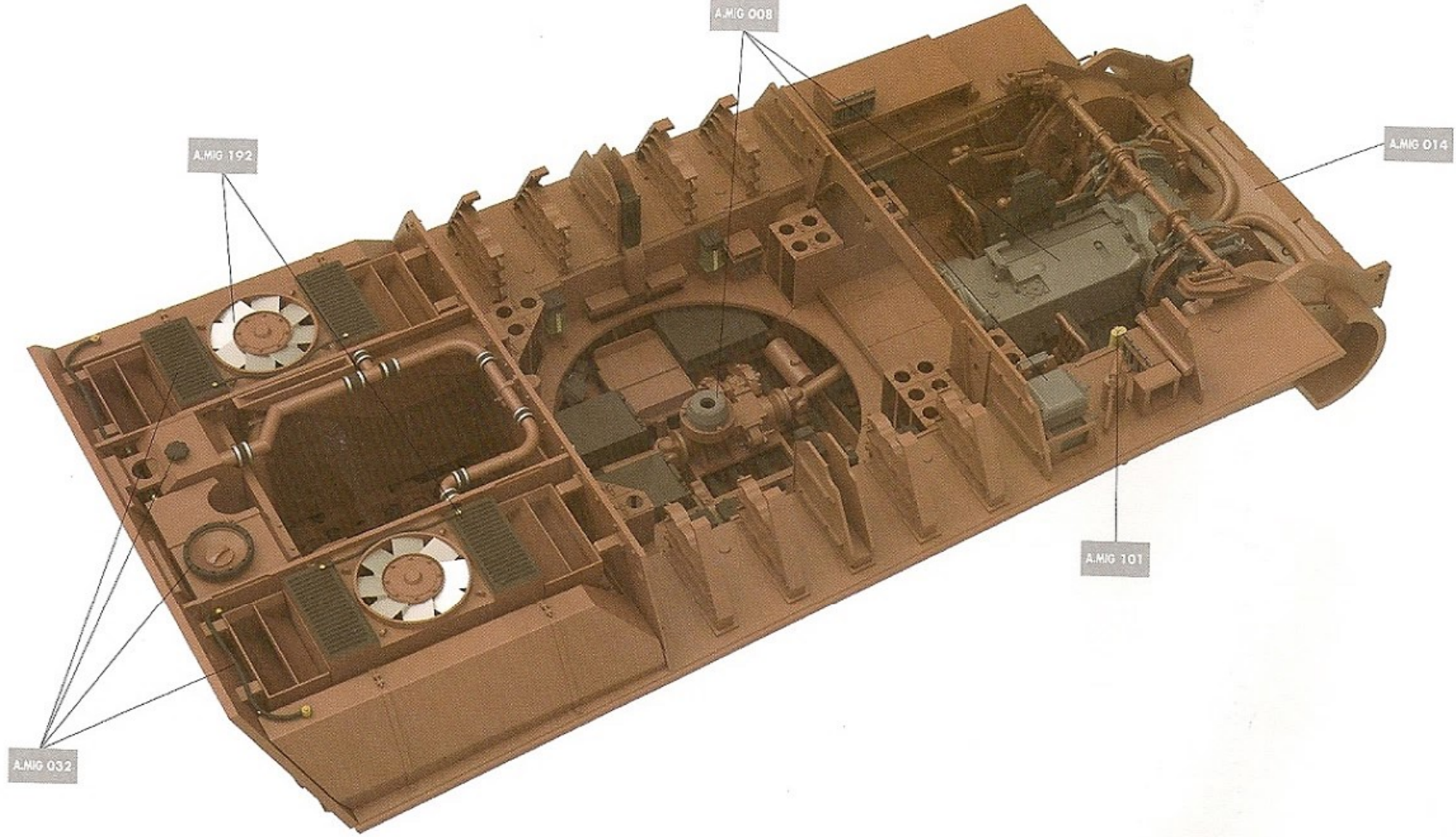



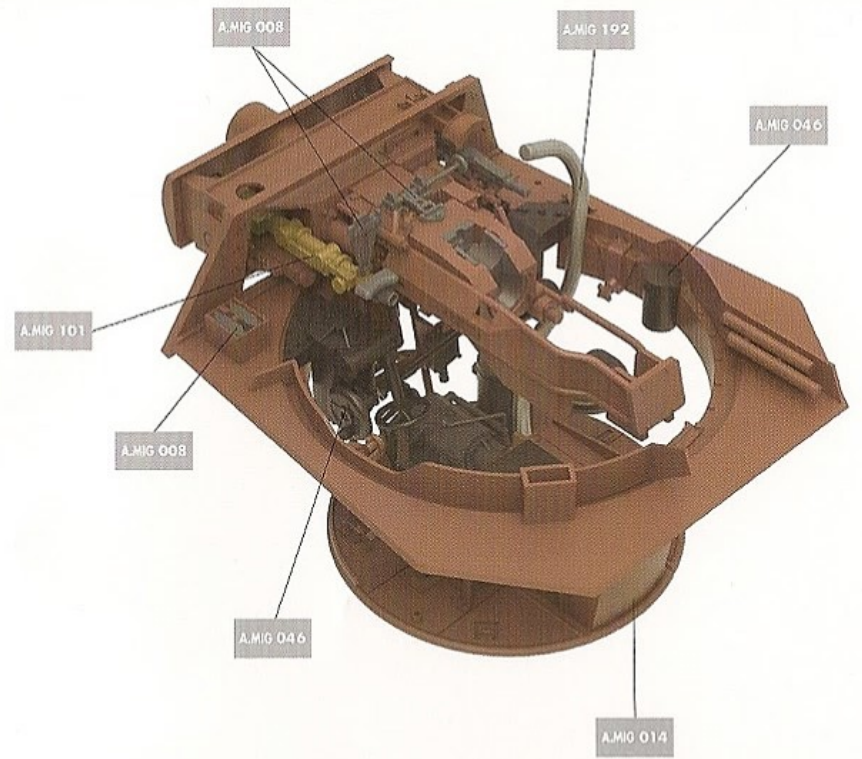
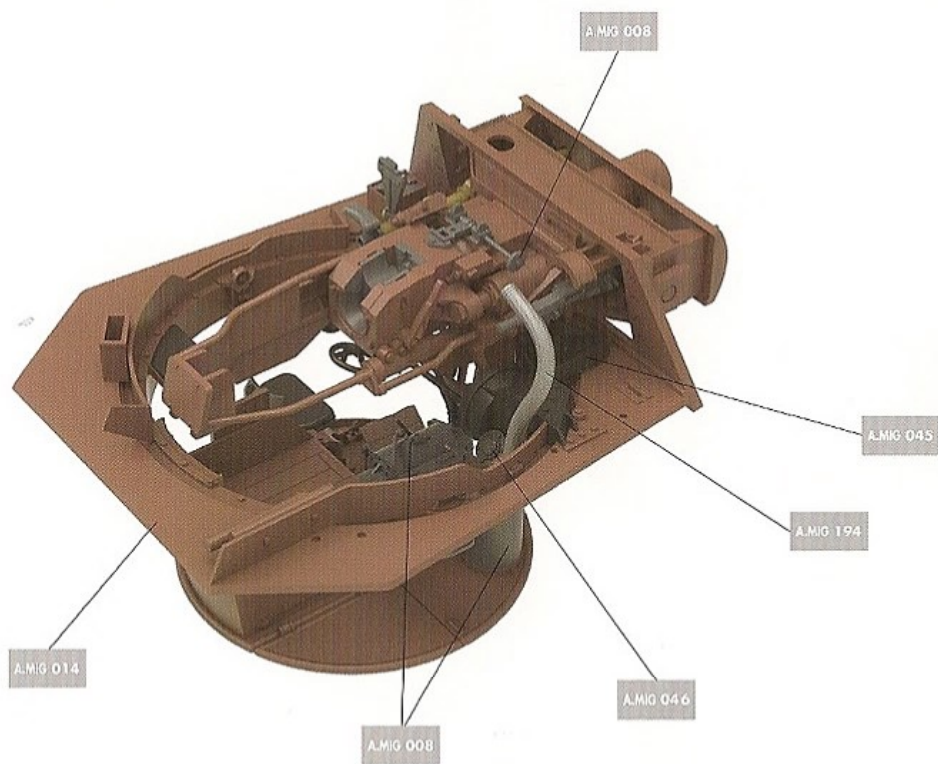

Option: Turret Interior - Creamweiss (A.MIG 017) from February 1945

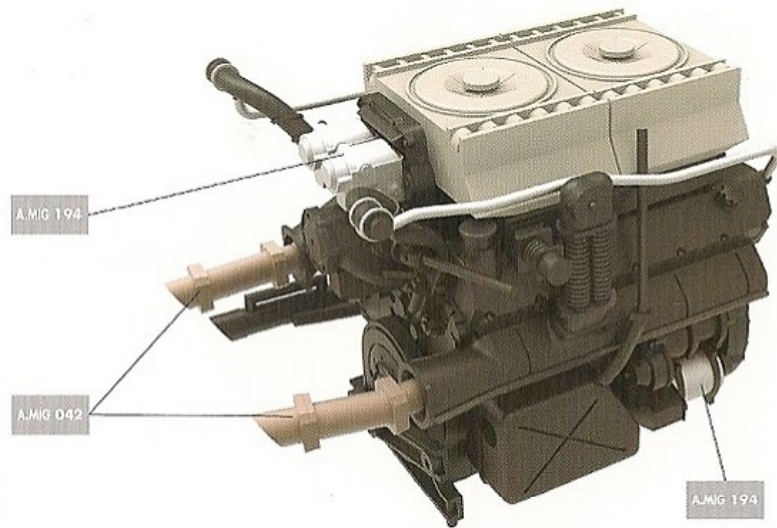



2019/2121

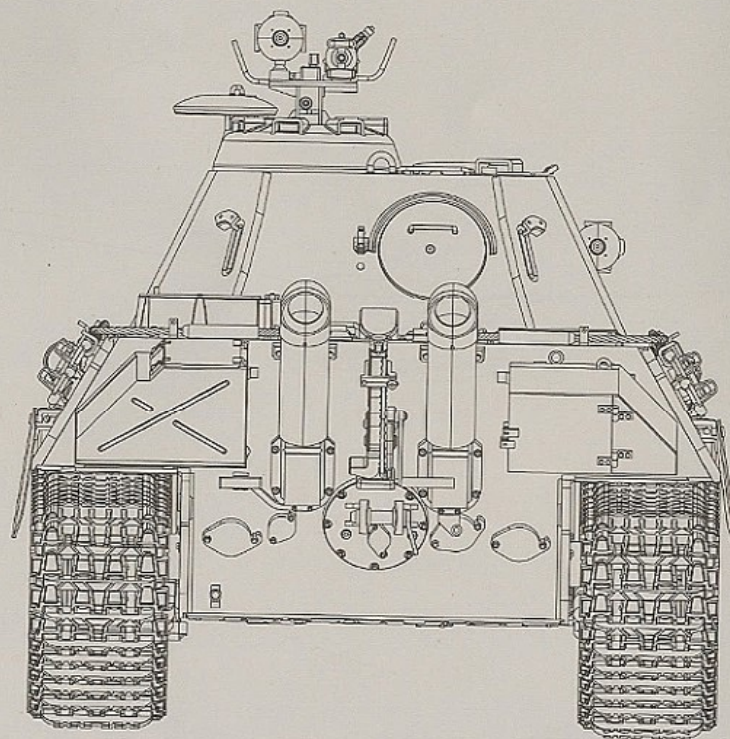

You can find TAKOM on Facebook.com