

# F-15C™ Eagle™



## EN

The Mc Donnell Douglas F-15 is an all-weather single seat American fighter, developed with the specific goal to gain and maintain air superiority. The F-15 Eagle has been designed during the '70s to provide to U.S. Air Force a modern and extremely high performance advanced fighter. The F-15C is representing the more modern version and it is nowadays largely used by U.S. Air Force, U.S. National Guard, and by the Air Forces of several Countries as Japan, Israel, and Saudi Arabia. The F-15 took part to the Gulf War in 1991 and it was able to guarantee the air superiority to Coalition Forces. It has been the most effective fighters with an impressive high number of enemy planes shot down. Armed with a 20mm. M61 gun it can use a wide variety of air-to-air missiles. Thanks to the two powerful Pratt & Whitney F-100 after-burning turbofans engines, the "Eagle" is able to reach the maximum speed of Mach 2.5.

## FR

Le Mc Donnell Douglas F-15 est un chasseur «tous-temps» monoplace, réalisé et conçu pour garantir la «supériorité aérienne». Le F-15 Eagle fut imposé au cours des années 70 pour pouvoir équiper les unités de vol de la U.S. Air Force avec un chasseur avancé et très performant. Son évolution, représentée par la version «C», le F-15 est encore largement utilisé par le U.S. Air Force, par la U.S. National Guard et par les armées de l'air d'Israël, du Japon et de l'Arabie Saoudite. Le F-15C a participé activement à la première Guerre du Golfe en assurant la supériorité aérienne aux troupes de la Coalition en abattant le pourcentage le plus élevé des avions ennemis. Armé d'un canon M61 de 20 mm, il peut employer une vaste variété de missiles air-air. Les deux puissants moteurs Pratt & Whitney F 100 avec postcombustion permettent au F-15 d'atteindre la vitesse de Mach 2.5.

## IT

Il Mc Donnell Douglas F-15 è un caccia "ogni tempo" monoposto realizzato e progettato per garantire e mantenere la "superiorità aerea". L' F-15 Eagle venne impostato nel corso degli anni '70 per poter equipaggiare i reparti di volo della US Air Force con un caccia avanzato e dalle elevate prestazioni. Nella sua evoluzione, rappresentata dalla versione "C", l'F-15 è ancora largamente impiegato dall'U.S. Air Force, dalla U.S. National Guard e dalle forze aeree di Israele, Giappone e Arabia Saudita. L'F-15C ha preso parte attivamente alla prima Guerra del Golfo garantendo la superiorità aerea alla truppe della Coalizione con l'abbattimento della percentuale più elevata di aerei nemici. Armato con un cannone M61 da 20 mm può impiegare un'ampia varietà di missili aria-aria. I due potenti motori Pratt & Whitney F100 con postbruciatore consentono all'F-15C di raggiungere la velocità di Mach 2.5.

## ES

El Mc Donnell Douglas F-15 es un caza «clásico» de una plaza proyectado y fabricado para garantizar y mantener la «primacía aérea». El F-15 Eagle se propuso en los años 70 para poder equipar las divisiones de aviación de la Fuerza Aérea de los Estados Unidos de América con un caza avanzado que ofreciera altas prestaciones. En su evolución, representada por la versión «C», el F-15 aún es ampliamente utilizado por la Fuerza Aérea de los Estados Unidos de América, la National Guard y por las fuerzas aéreas de Israel, Japón y Arabia Saudí. El F-15C formó parte de manera activa en la primera Guerra del Golfo, garantizando en todo momento la superioridad aérea de las tropas de la Coalición, con el porcentaje más elevado de derribo de aviones enemigos. Va armado con un cañón M61 de 20 mm, que puede emplear una amplia variedad de misiles tierra-aire. Los dos potentes motores Pratt & Whitney F100 con postquemador del F-15C le permiten alcanzar la velocidad de Mach 2,5.

## DE

Der Mc Donnell Douglas F-15 ist ein einsitziger Jäger für „jedes Wetter“, der zur Herstellung und Erhaltung der „Luftüberlegenheit“ konzipiert und gefertigt wurde. Der F-15 Eagle wurde im Laufe der 70er Jahre entworfen, um die Flugabteilungen der US Air Force mit einem weiterentwickelten und leistungsfähigen Jäger ausstatten zu können. In seiner Weiterentwicklung, vertreten durch die „C“-Version, findet der F-15 weiterhin breite Verwendung in der US Air Force, der US Nationalgarde und der israelischen, japanischen und saudischen Luftwaffe. Der F-15 war aktiv am ersten Golfkrieg beteiligt und hat mit der höchsten Abschussrate feindlicher Flugzeuge, den Erhalt der Luftüberlegenheit der Koalitionstruppen gewährleistet. Ausgestattet mit einer 20 mm Kanone M61, kann er eine breite Auswahl an Luft-Luft-Raketen abfeuern. Die beiden leistungsstarken Pratt & Whitney Motoren F100 mit Nachbrenner, erlauben dem F-15C eine Geschwindigkeit von Mach 2,5 zu erreichen.

## RU

Макдоннел-Дуглас F-15 «Игл» - это американский всепогодный одноместный истребитель, разработанный и предназначенный для «завоевания превосходства в воздухе». F-15 Eagle был принят на вооружение в 70-х годах для оснащения авиационных подразделений ВВС США передовыми истребителями с высокими эксплуатационными характеристиками. Последняя из модификаций истребителя F-15 - серия «С» всё ещё находится на вооружении ВВС США, Национальной гвардии США, а также ВВС Израиля, Японии и Арабских эмиратов. Истребитель F-15 активно участвовал в первой войне в Персидском заливе, обеспечивая превосходства в воздухе войскам коалиции, истребив самый высокий процент вражеских самолетов. Оснащённый шести ствольной 20-мм пушкой M61, он может использовать широкий диапазон ракет воздух-воздух. Два мощных реактивных двигателя Pratt & Whitney F100 с форсажным режимом позволяют истребителю F-15C достигать скорости с величиной числа Mach 2,5.



- EN WARNING:** Model for adult collector age 14 and over  
**IT ATTENZIONE:** Modello per collezionisti adulti di età superiore ai 14 anni  
**FR ATTENTION:** Modèle pour modélistes de 14 and et plus.  
**DE ACHTUNG:** Modellbausätze Für Modellbauer über 14 Jahre.  
**NL WAARSCHWING:** Geschikt voor 14 jaar en ouder.  
**ES ATENCION:** Modelo para modelistas mayores de 14 años.

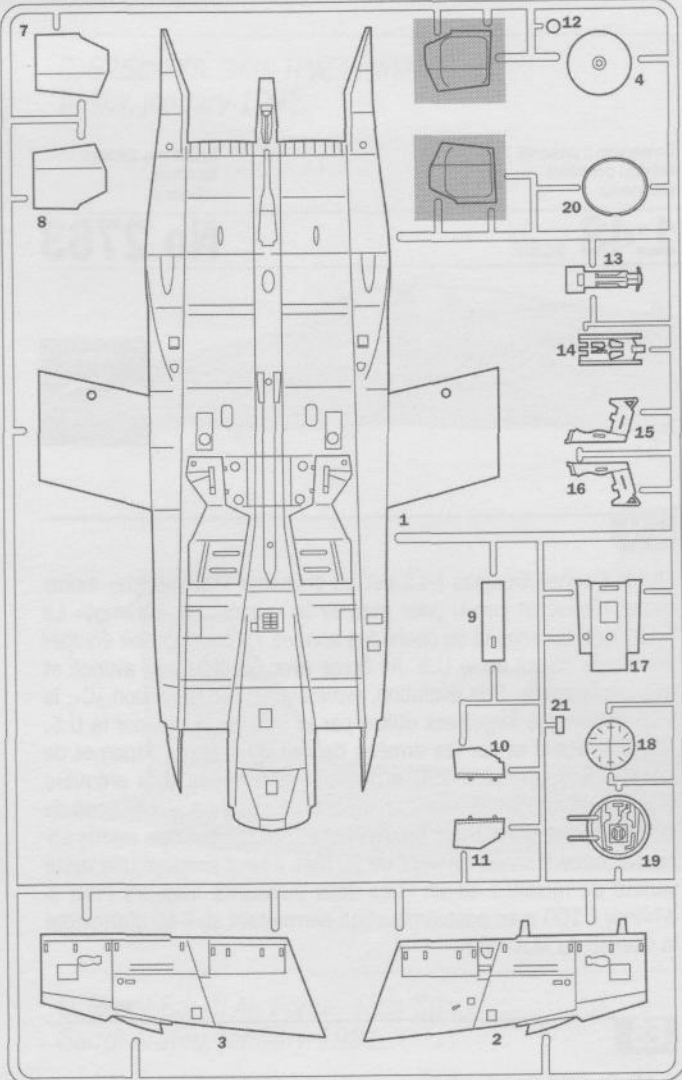

A

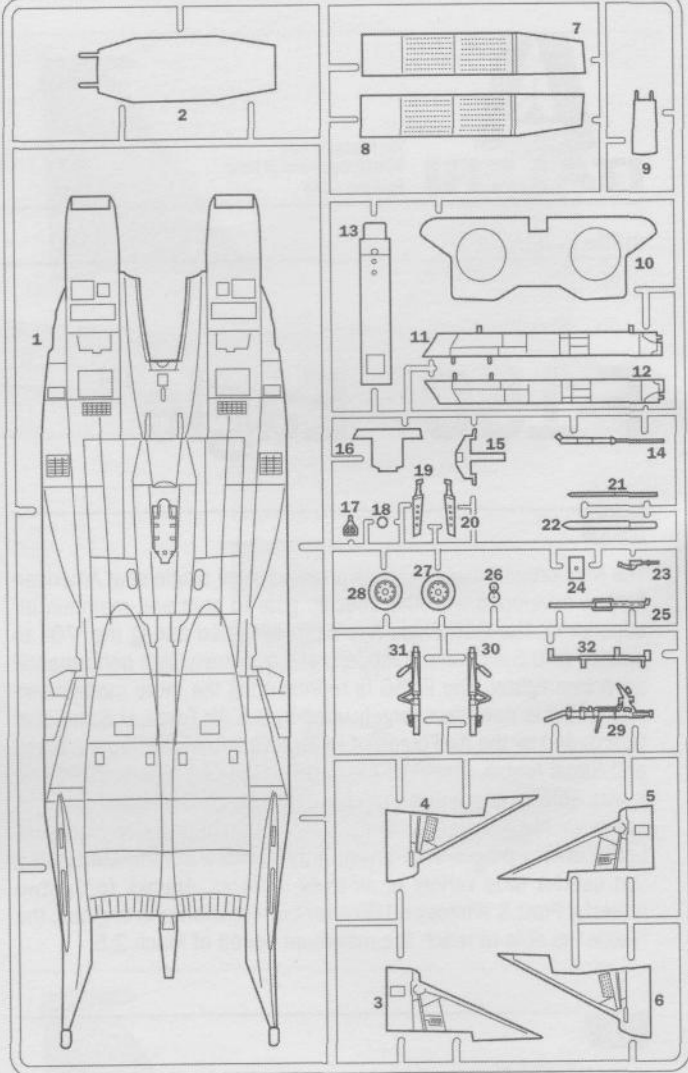

B

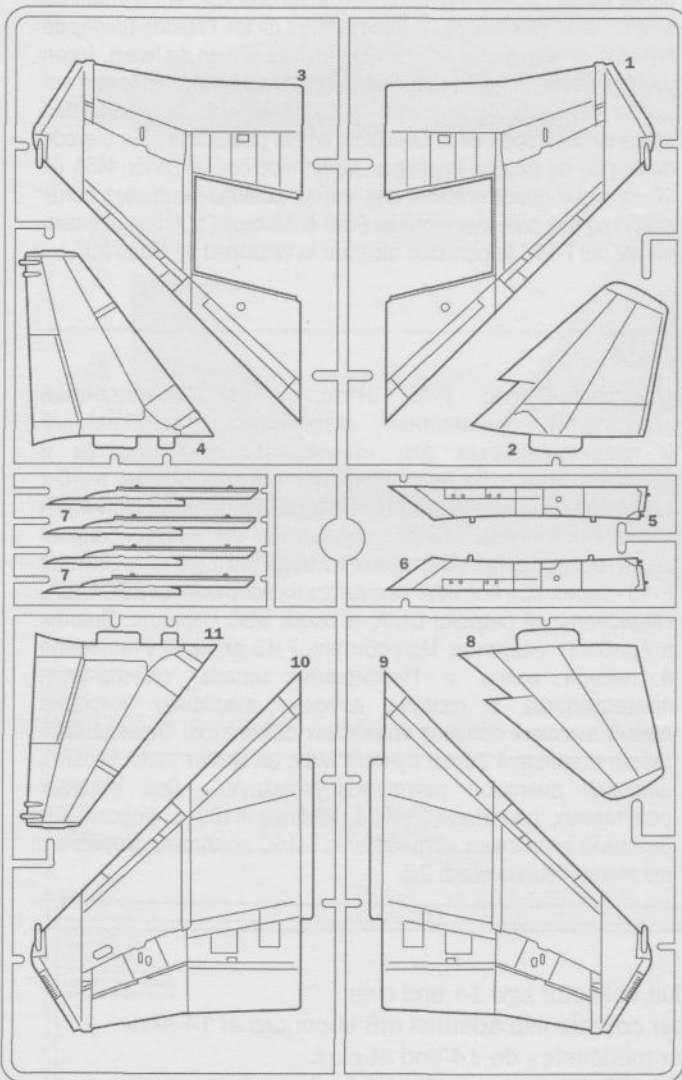

C



Parts not for use  
 Teile werden nicht  
 verwendet  
 Parti da non utilizzare  
 Pièces à ne pas  
 utiliser

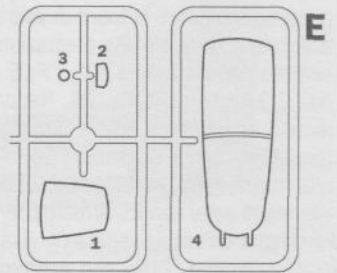

E

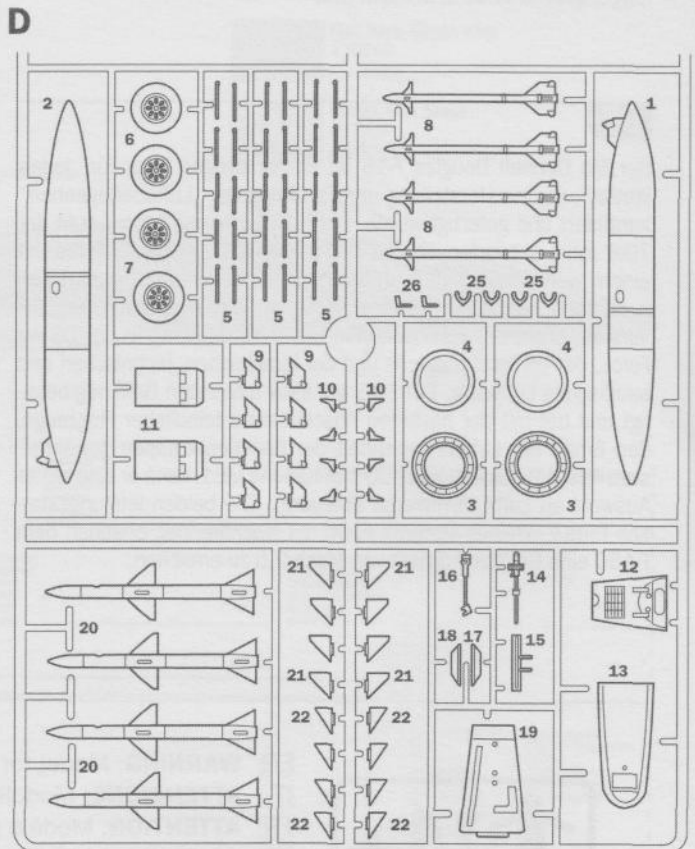

D

## Color Table

**A** FLAT BLACK - 4768AP F.S. 37038

**B** FLAT LIGHT GHOST GRAY - 4762AP F.S. 36300

**C** FLAT OLIVE DRAB - 4315AP F.S. 34088

**D** FLAT DARK GHOST GRAY - 4761AP F.S. 35237

**E** FLAT INSIGNA YELLOW - 4721AP F.S. 33538

**F** GLOSS GREEN - 4669AP F.S. 14090

**G** METAL FLAT ALUMINIUM - 4677AP F.S. 37178

**H** FLAT GUN METAL - 4681AP F.S. 37200

**I** GLOSS WHITE - 4696AP F.S. 17875

**L** METAL FLAT STEEL - 4679AP F.S. 37178

**M** GLOSS RED - 4605AP F.S. 11302

**N** GLOSS BLUE - 4659AP F.S. 15180

I numeri si riferiscono all'assortimento Italeri Acrylic Paint  
 The indicated colour number refer to the Italeri Acrylic Paint  
 Les références indiquées concernent les peintures Italeri Acrylic Paint  
 Die angegebenen farbnummern beziehen sich auf die Italeri Acrylic Paint  
 Los números se refieren a los colores surtido Italeri Acrylic Paint  
 De nummers verwijzen naar het assortiment kleuren Italeri Acrylic Paint

1

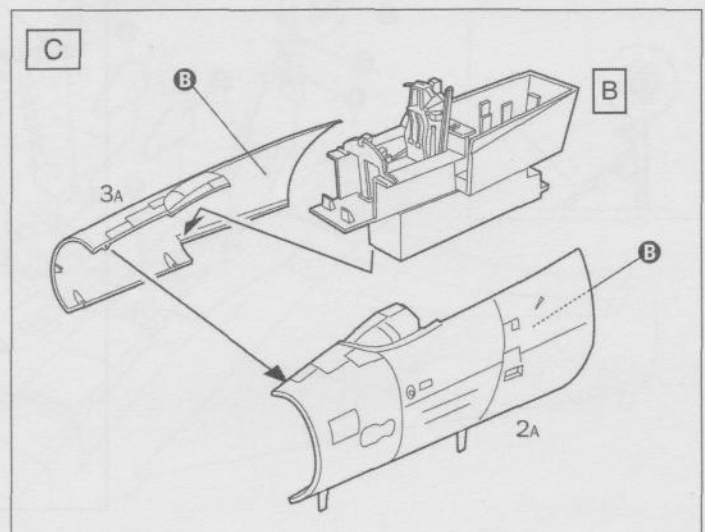
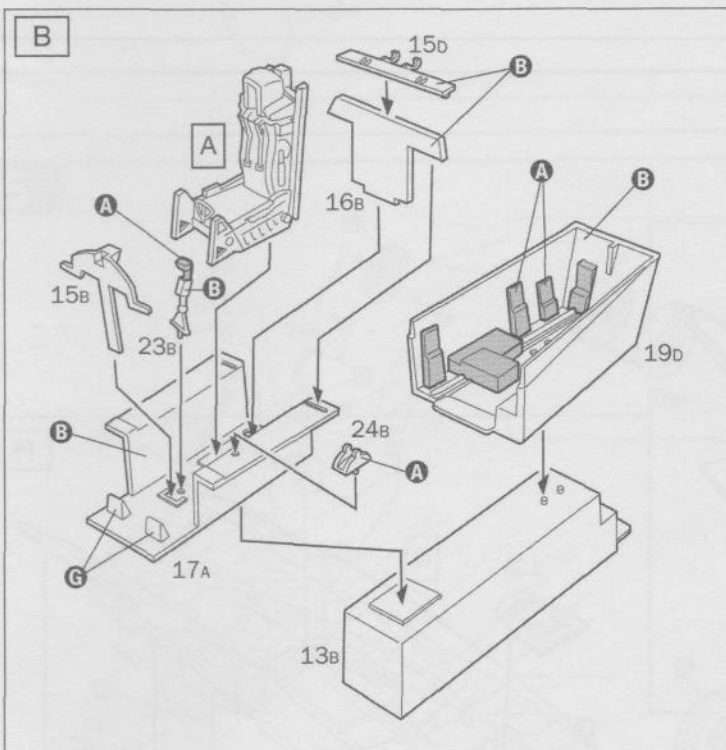
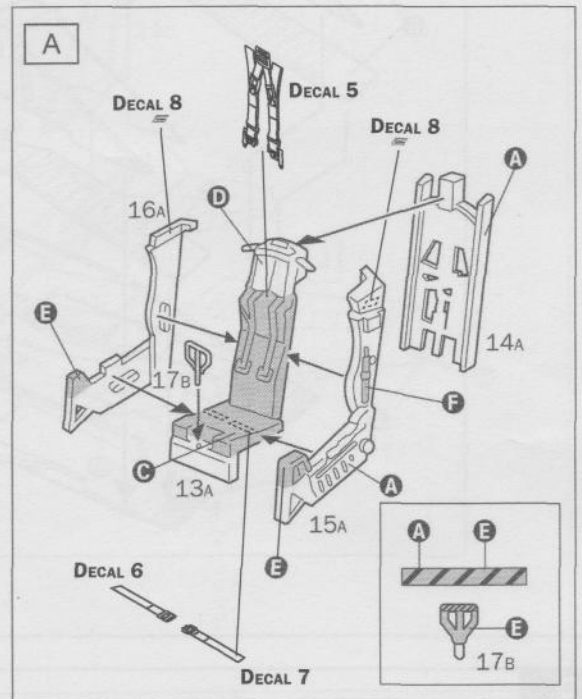
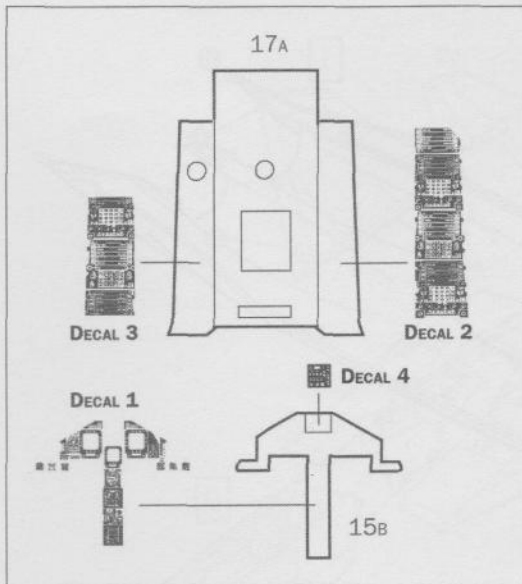

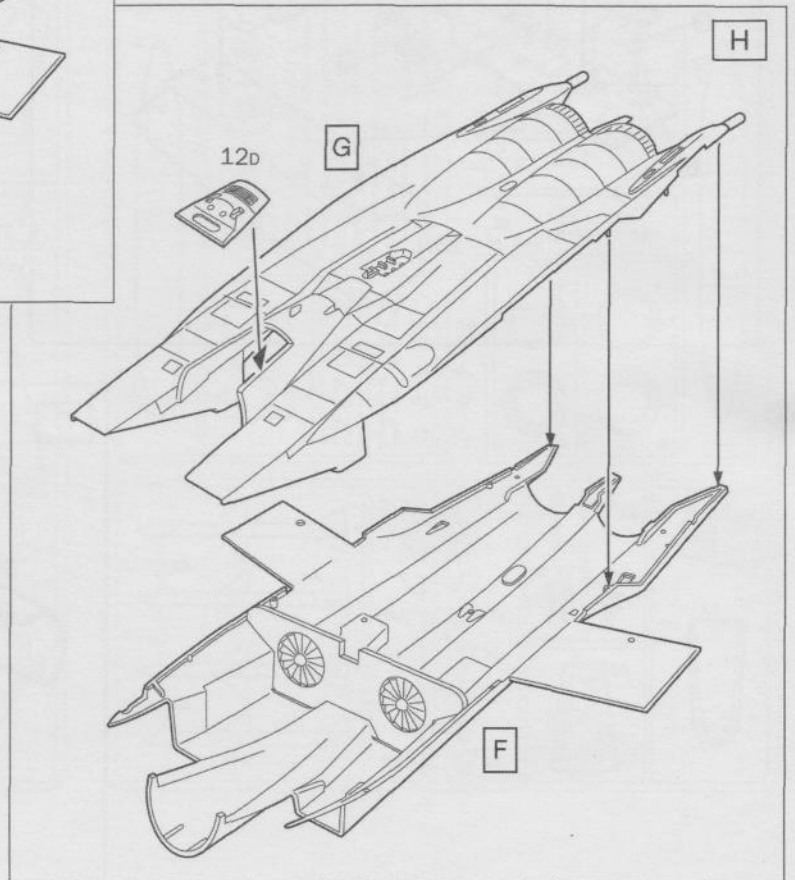
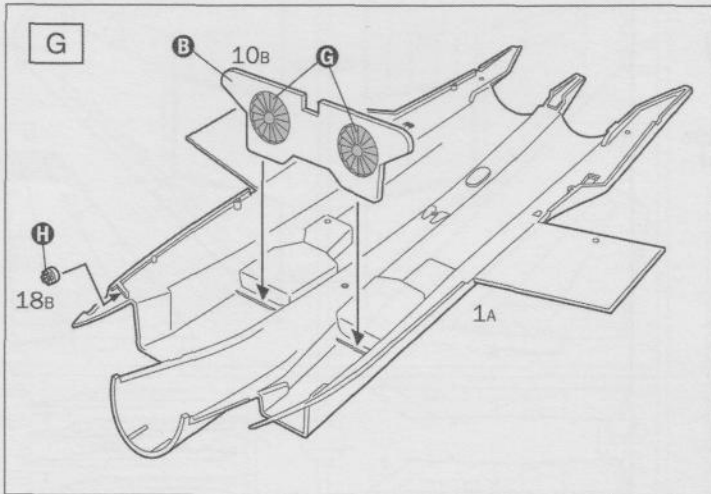
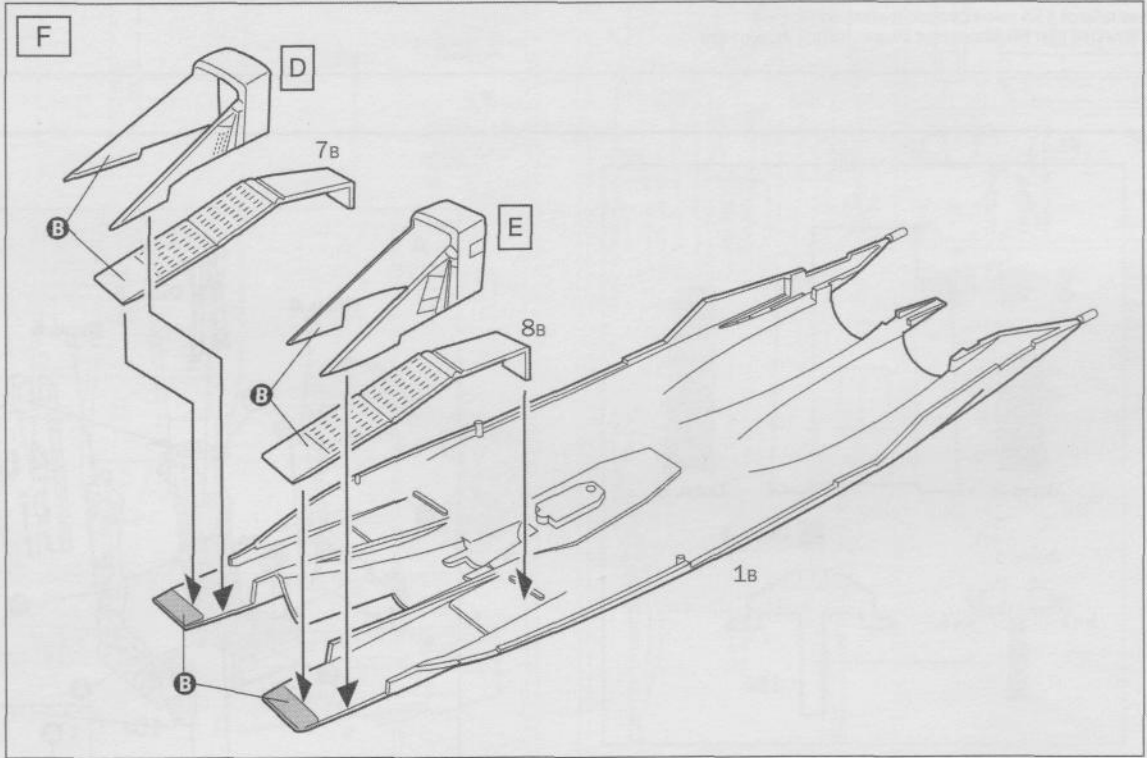
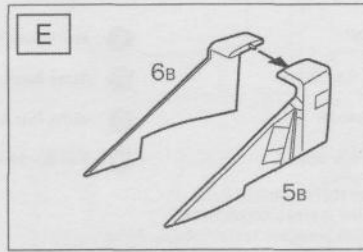
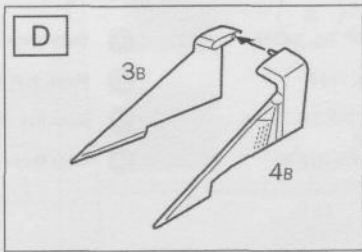

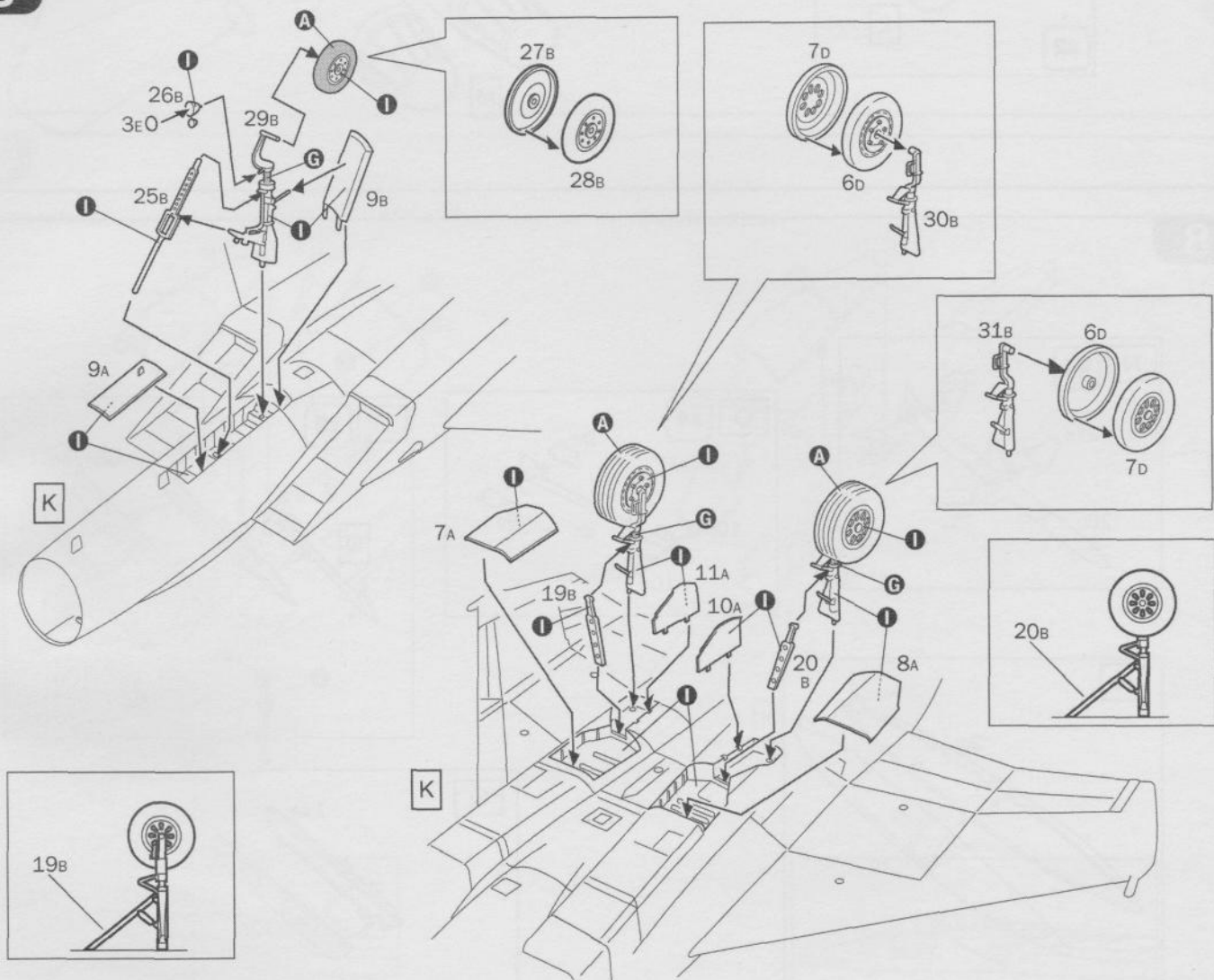
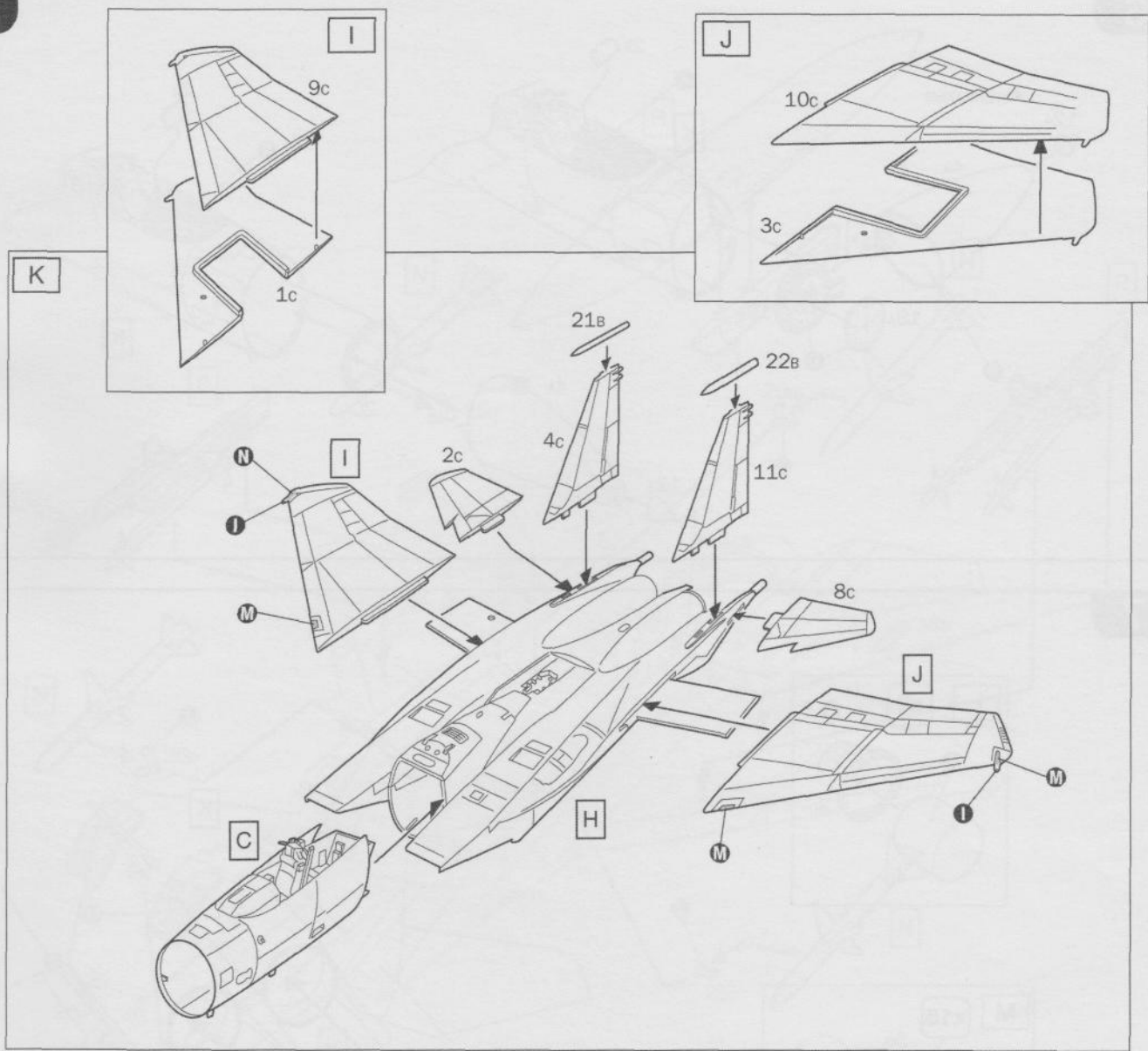

6

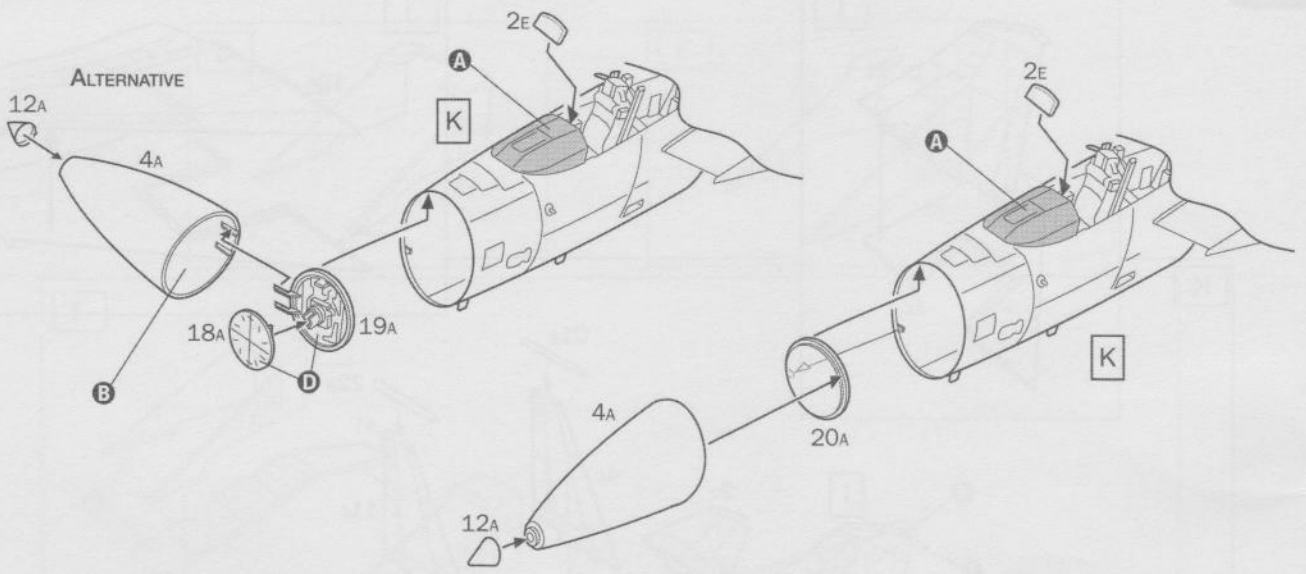

7

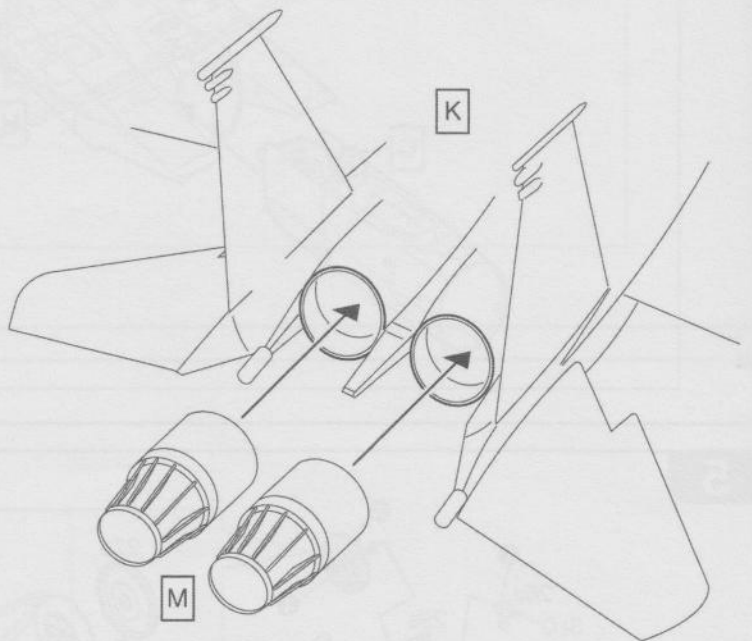
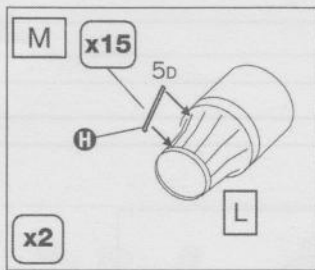
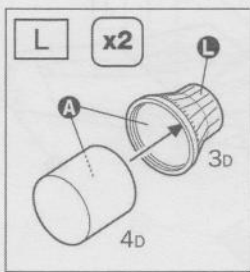

8

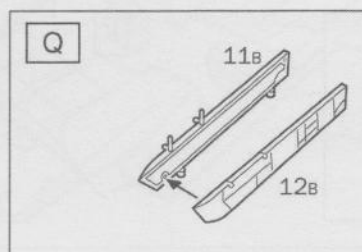
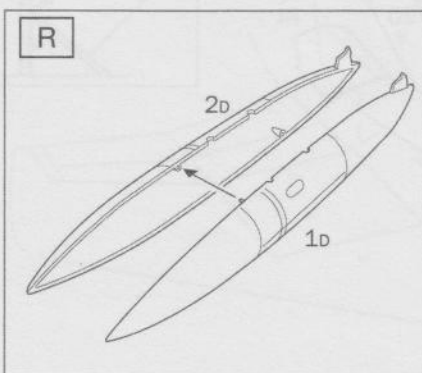
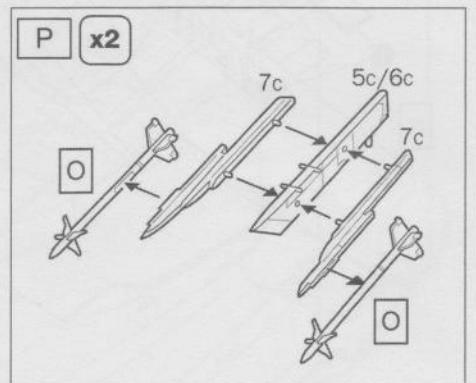
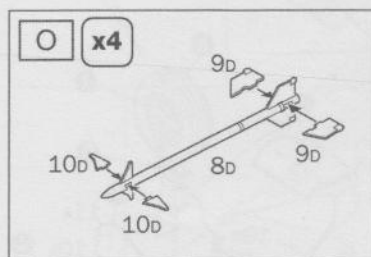
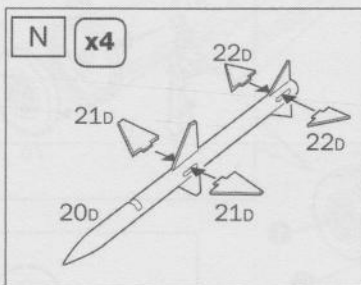

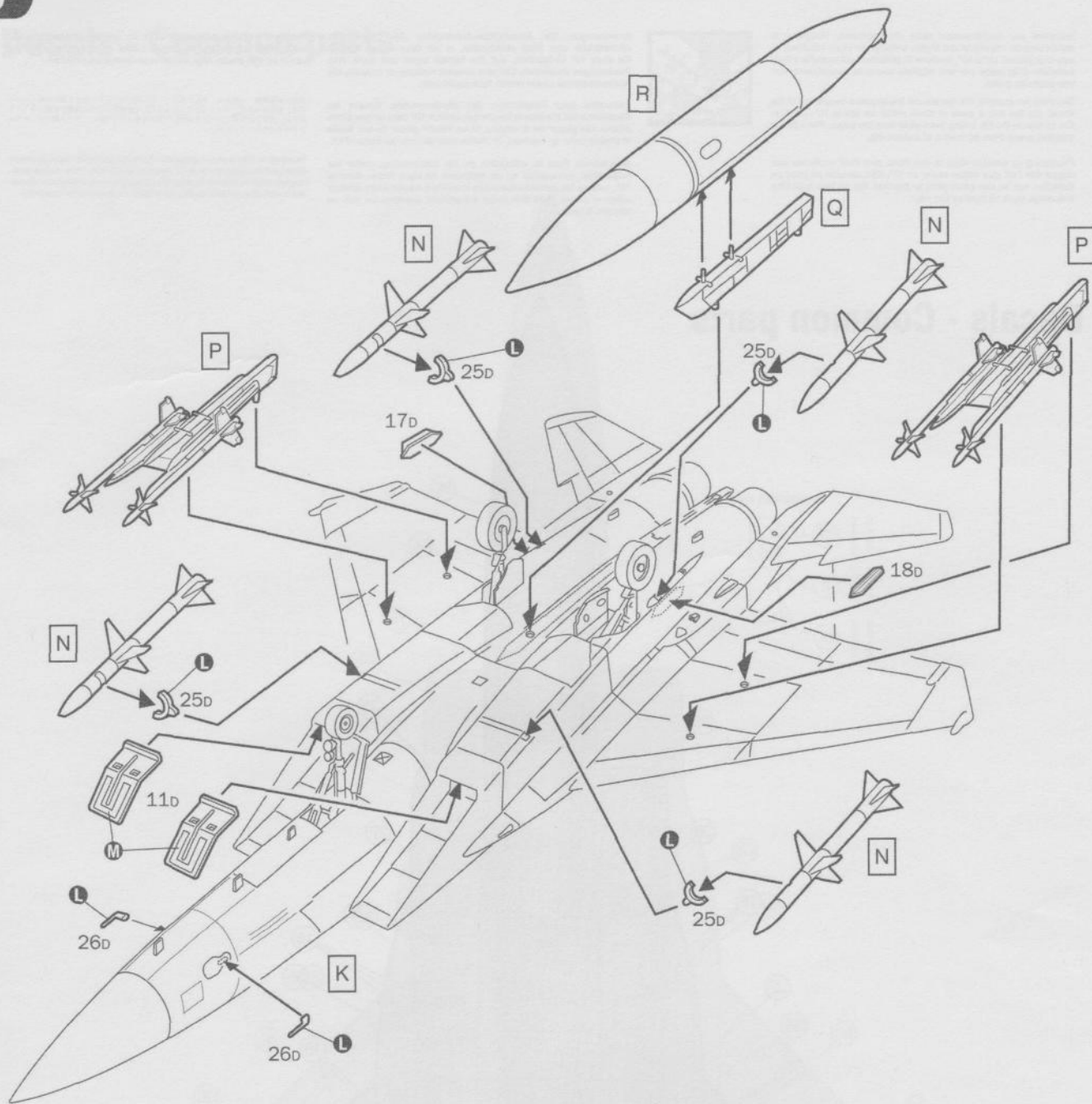

OPEN VERSION

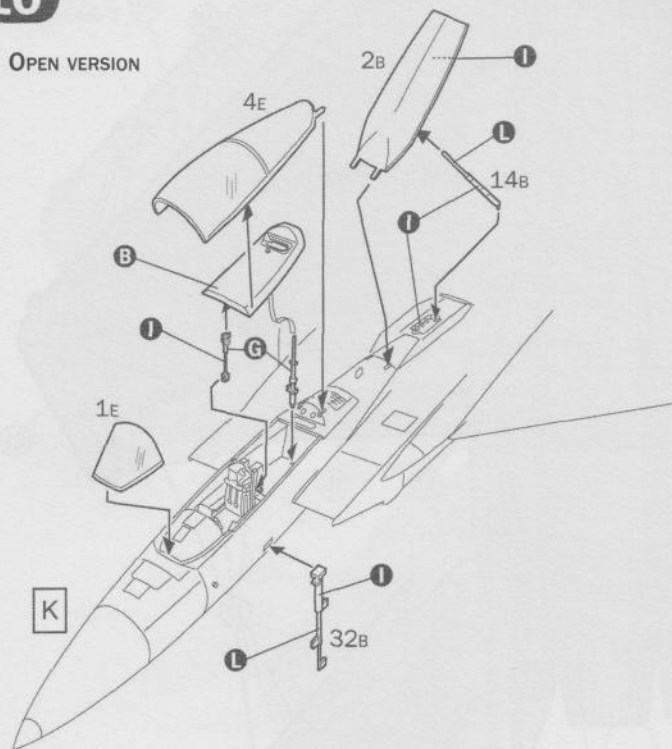

CLOSED VERSION

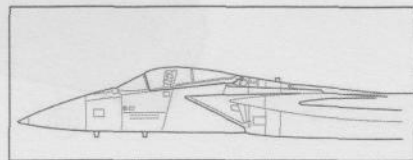
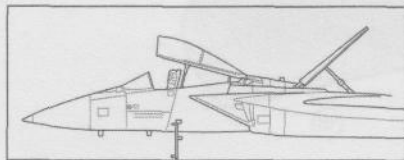
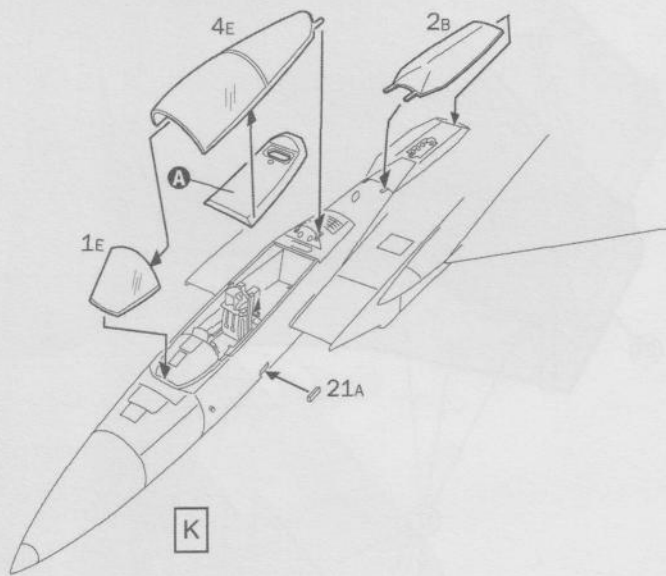

Istruzioni per l'applicazione delle decalcomanie. Ritagliare le decalcomanie occorrenti dal foglio, immergerle in un bicchiere di acqua pulita per circa 10", metterle in posizione sul modello e farle scivolare dalla carta: per una migliore aderenza comprimerle con una pezzuola pulita.

Direction for applying the decals: cut the required decals out of the sheet; dip the into a glass of clean water for about 10"; position the decals on the kit, letting them slide from the paper. For a better adesion, press them by means of a clean rag.

Påläggning av decaler: klipp ut den decal som skall användas och doppa den i ett glas vatten under en 10". Sätt decalen på plats på modellen och låt den sakta glida av pappret. För att den skall sitta ordentligt, tryck till med en torr duk.



Anweisungen für Abziehbilder-Anbringung: Die benötigten Abziehbilder vom Blatt abschneiden, in ein Glas reines Wasser für etwa 10" eintauchen, auf das Modell legen und dann vom Papierbogen abnehmen. Um eine bessere Haftung zu erzielen, die Abziehbilder mit einem reinen Tuch andrücken.

Instruction pour l'application des décalcomanies. Couper les décalcomanies choisies et les plonger environ 10" dans un peu d'eau propre. Les placer sur le modèle en les faisant glisser de leur feuille et presser avec un morceau de chiffon pur éliminer les bulles d'air.

Istrucciones Para la aplicación de las calcomanías: cortar las requeridas, sumergirlas en un recipiente de agua limpia durante 10", colocar las calcomanías sobre el modelo, haciéndolas deslizar sobre el papel. Para una mejor adherencia, presionarlas con un trapo limpio.

Transfers: knip het benodigde deel uit, dempel et ca. 10" onder water, oudt het transfer tegen het model en schuif het vanaf het papier op zijn plaats. Met een schoon doekje aandrukken.

デカール使用法: 白紙から、それぞれのマークを切り取ります。ぬるま湯に20秒くらいつけて、引き上げます。マークを模型の表面に押しつけておき、指定の位置にはってください。やわらかい布でマーク上を押しつけて気泡を駆ってください。マーク裏には、かわかまで手を触れないでください。

Указания по применению декалей: Отрежьте нужную вам часть декалей от общего листа, поместите ее на 1/2 минуты в чистую воду, затем, выбрав необходимое место на модели, переведите гуашь изображение, сдвинув его с бумажной основой. Для лучшего прилипания промажьте декаль чистой тряпочкой.

## Decals - Common parts

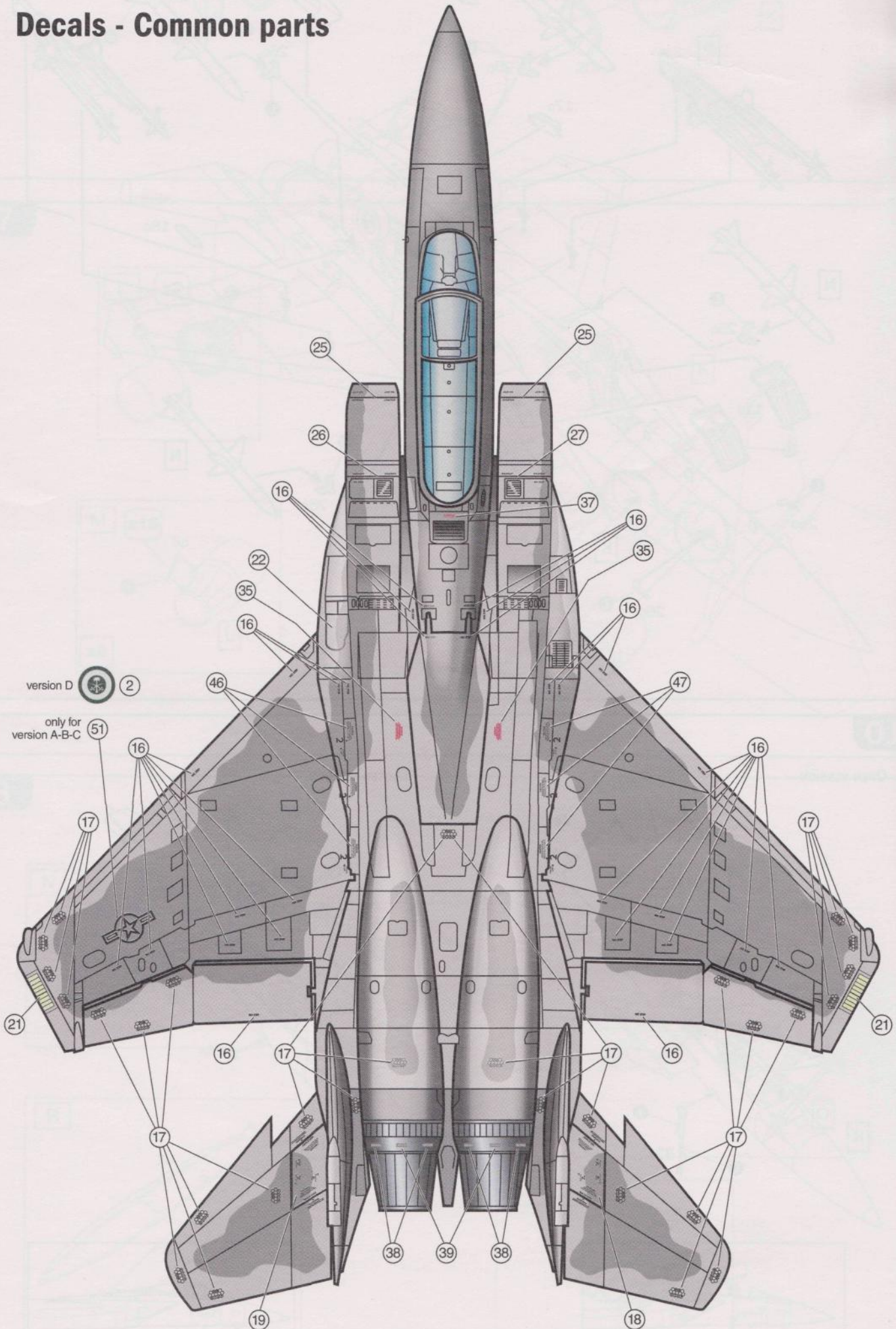



# Decals - Common parts

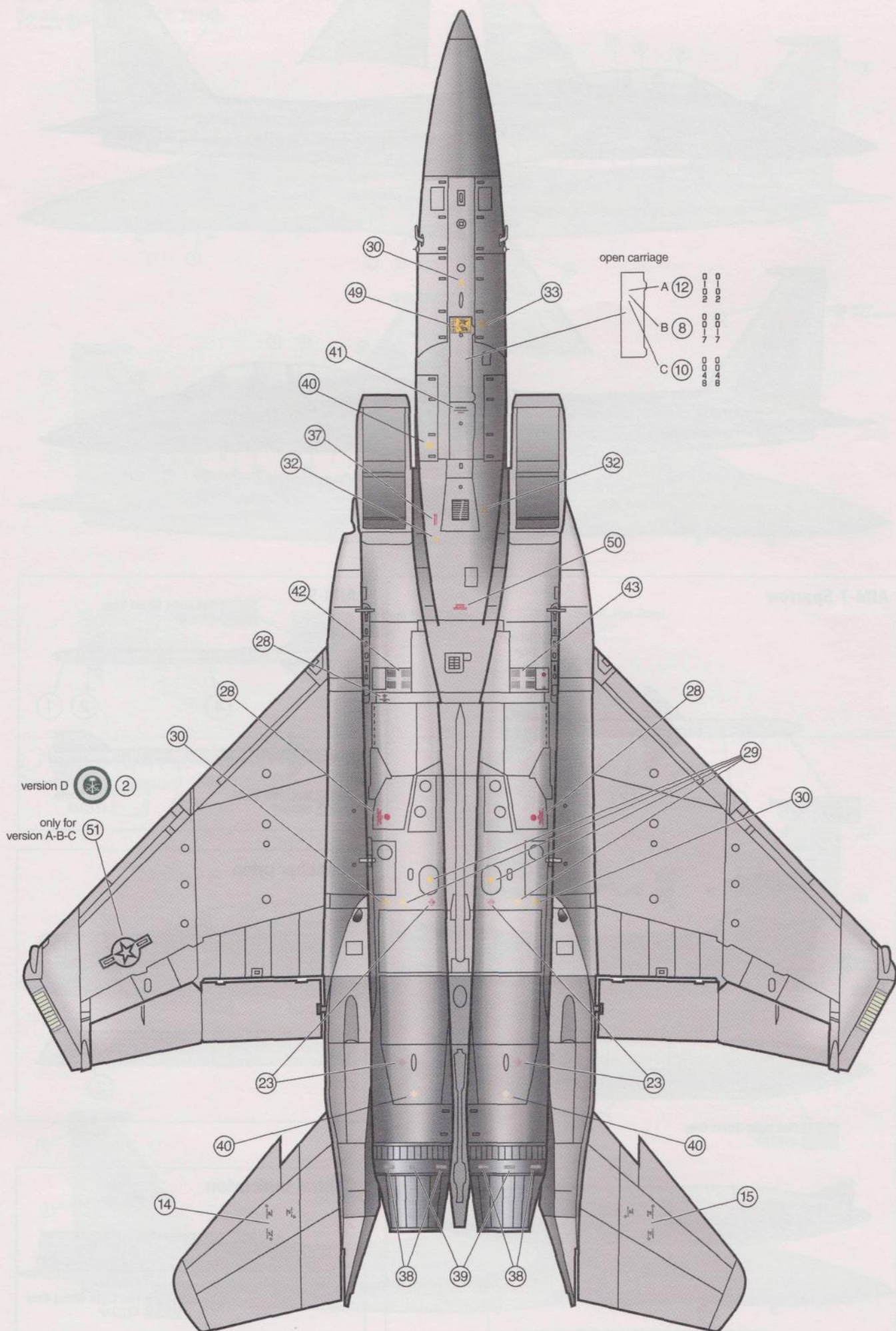

# Decals - Common parts

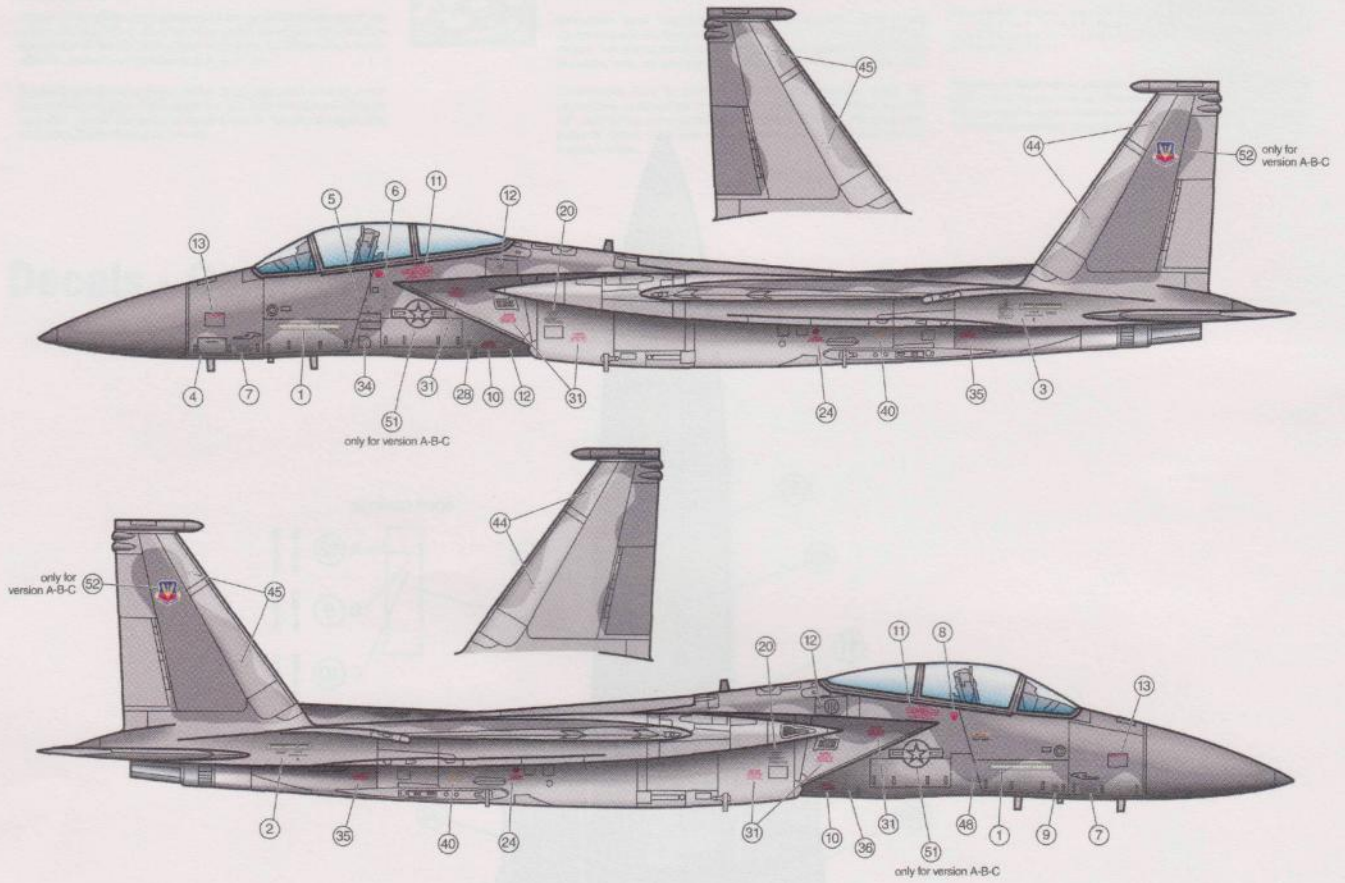

## AIM-7 Sparrow

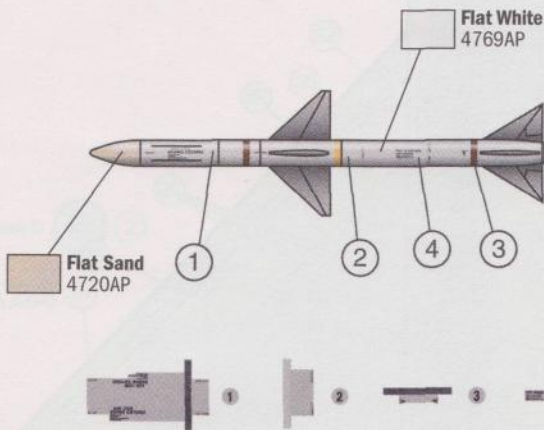

## AIM-9M

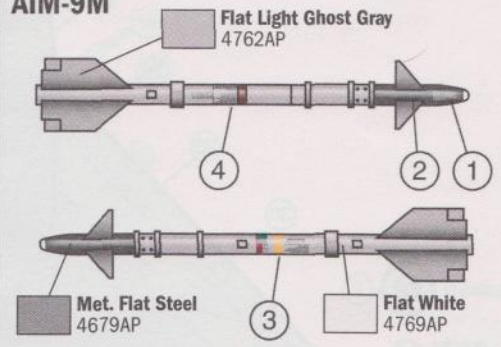

## Launcher pylon

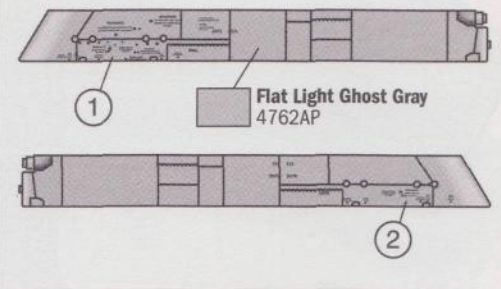

## Tank

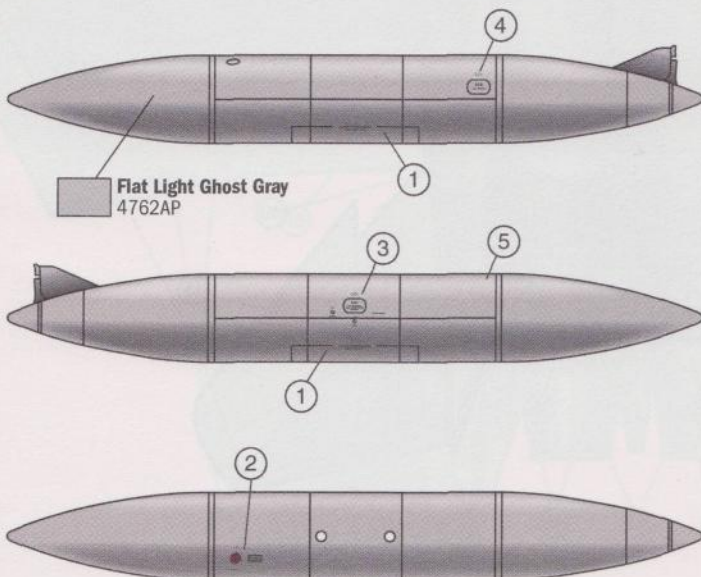

## Central tank pylon

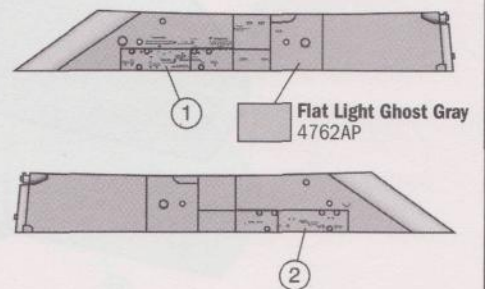

# Decals and colors - Single versions

A. 58th TFS, 33rd TFW, Tabuk AB,  
Saudi Arabia, march 1991.

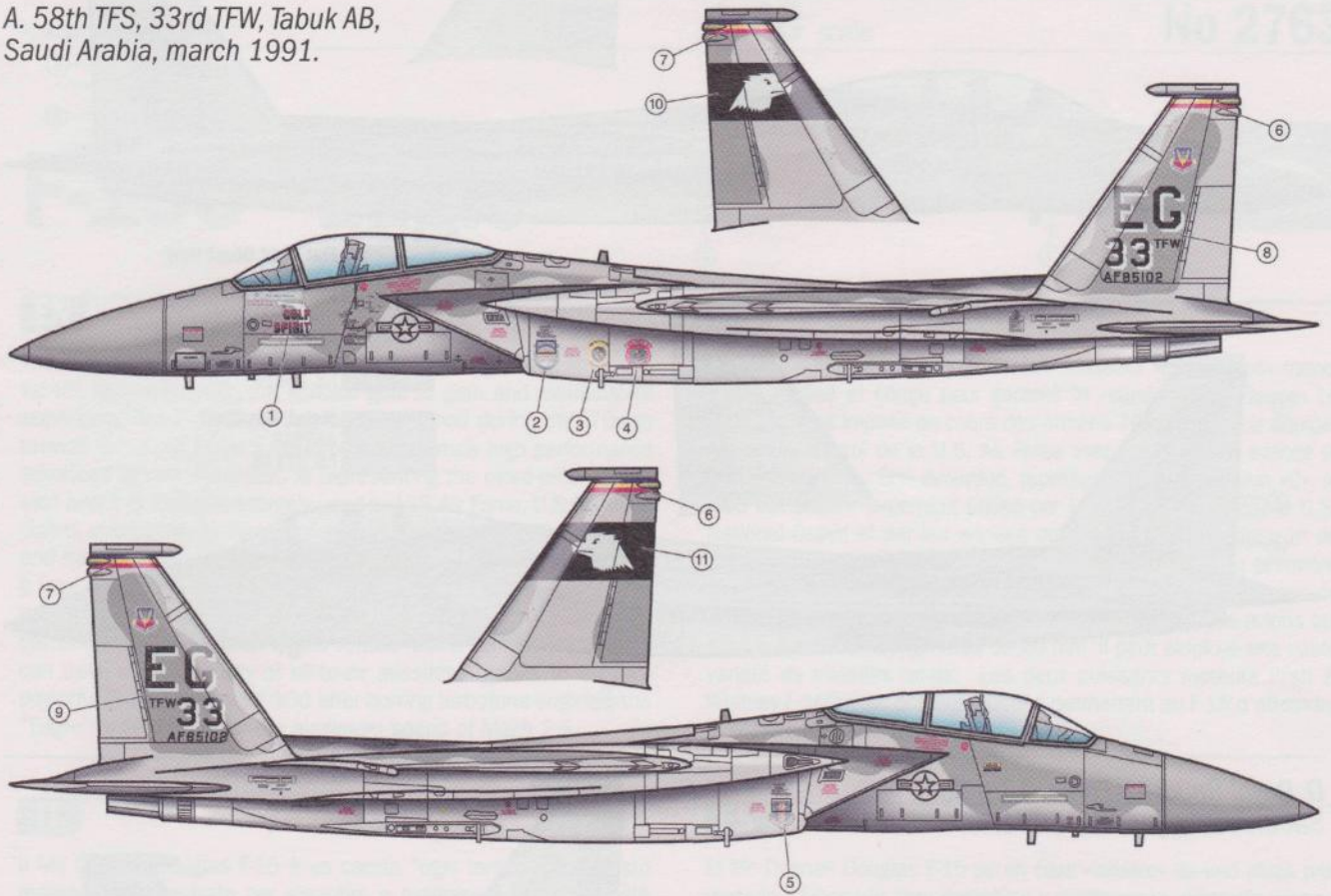

Flat Light Ghost Gray  
4762AP  
F.S. 36300

Flat Dark Ghost Gray  
4761AP  
F.S. 35237

Metal. Flat Steel  
4679AP  
F.S. 37178

B. 71st TFS, 1st TFW, Dhahran AB,  
Saudi Arabia, january 1991.

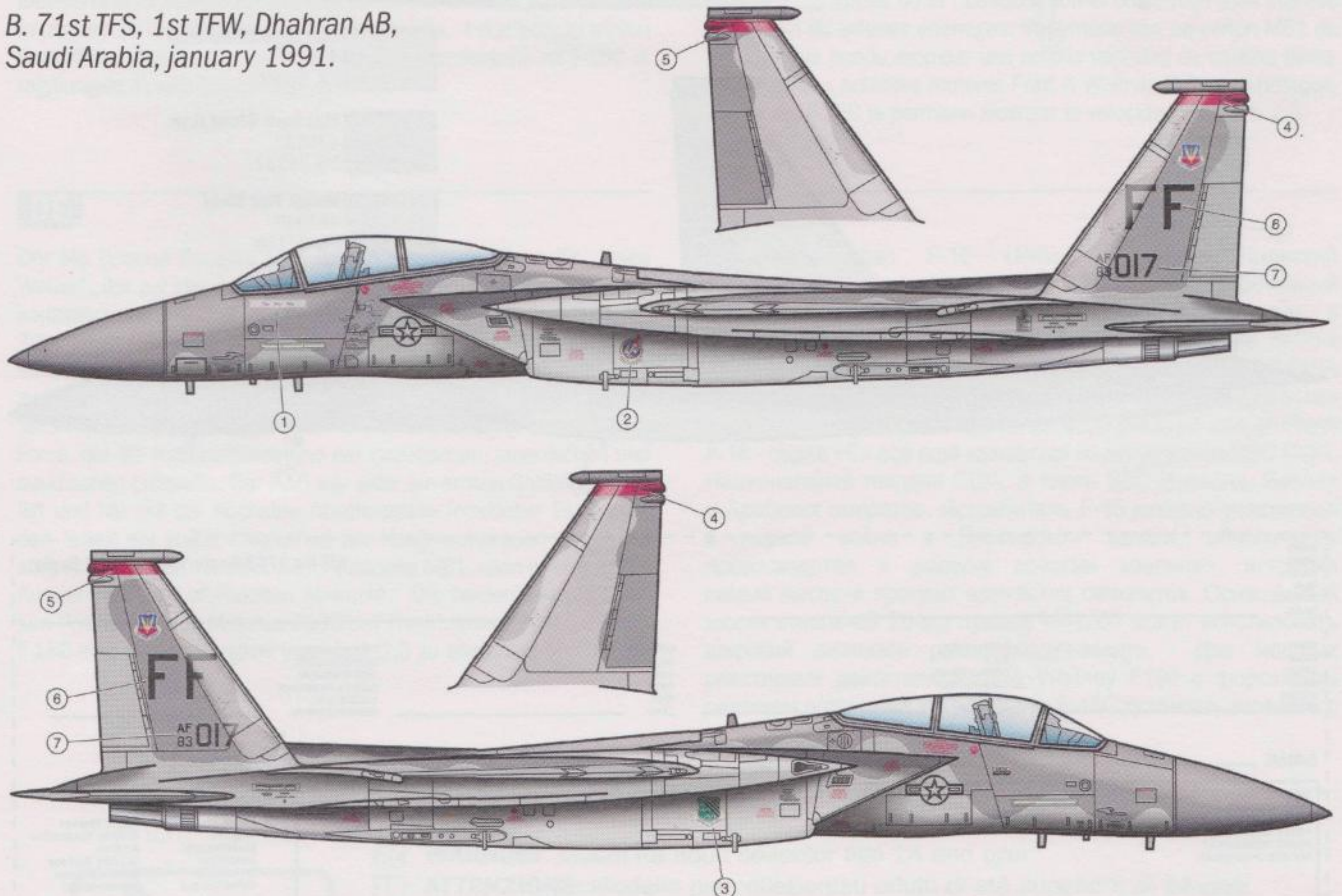

Flat Light Ghost Gray  
4762AP  
F.S. 36300

Flat Dark Ghost Gray  
4761AP  
F.S. 35237

Metal. Flat Steel  
4679AP  
F.S. 37178

C. 525th TFS, 36th TFW, Incirlik AB,  
Turkey, January 1991.

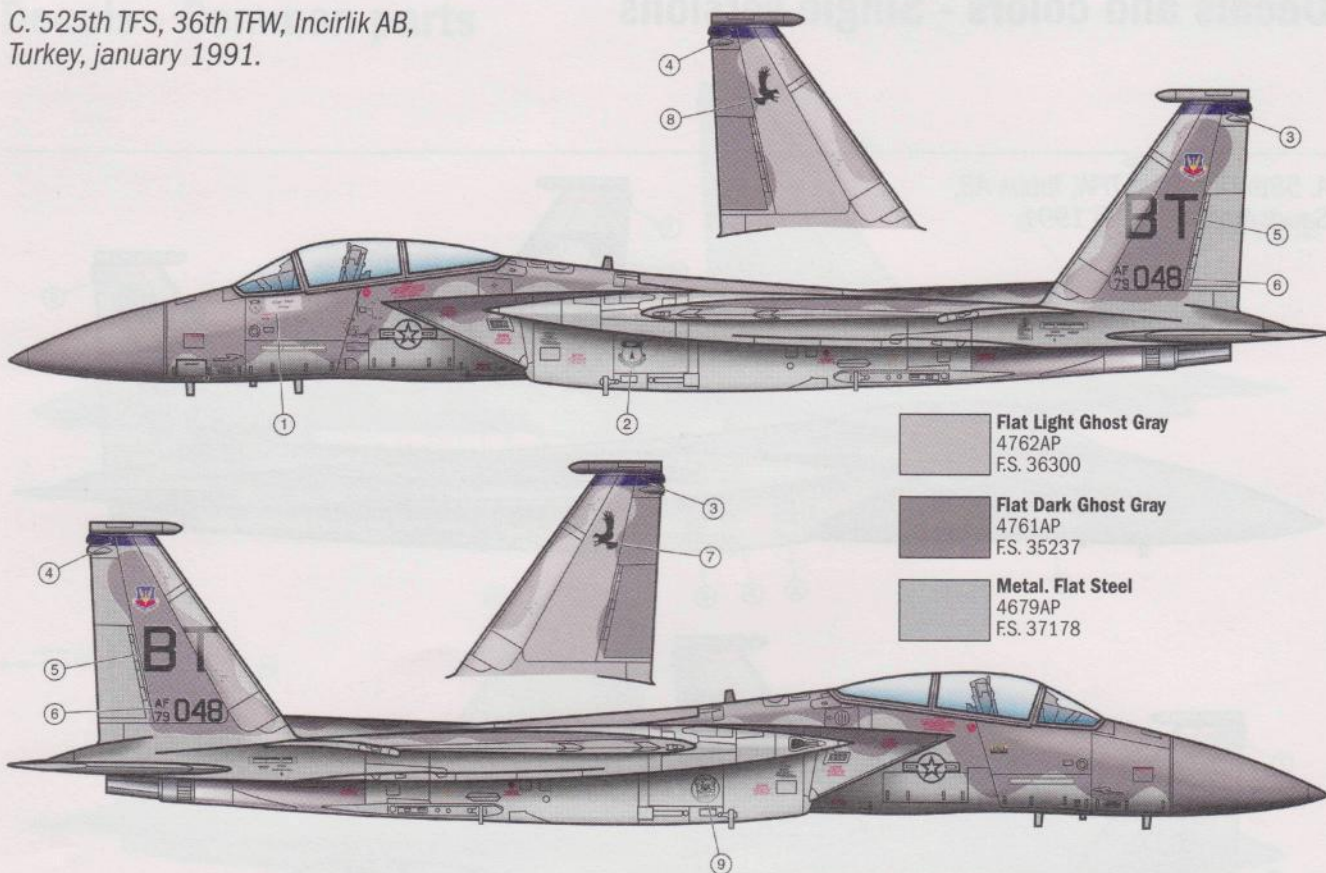

D. Royal Saudi Air Force, 13th Sqn.,  
Saudi Arabia, January 1991.

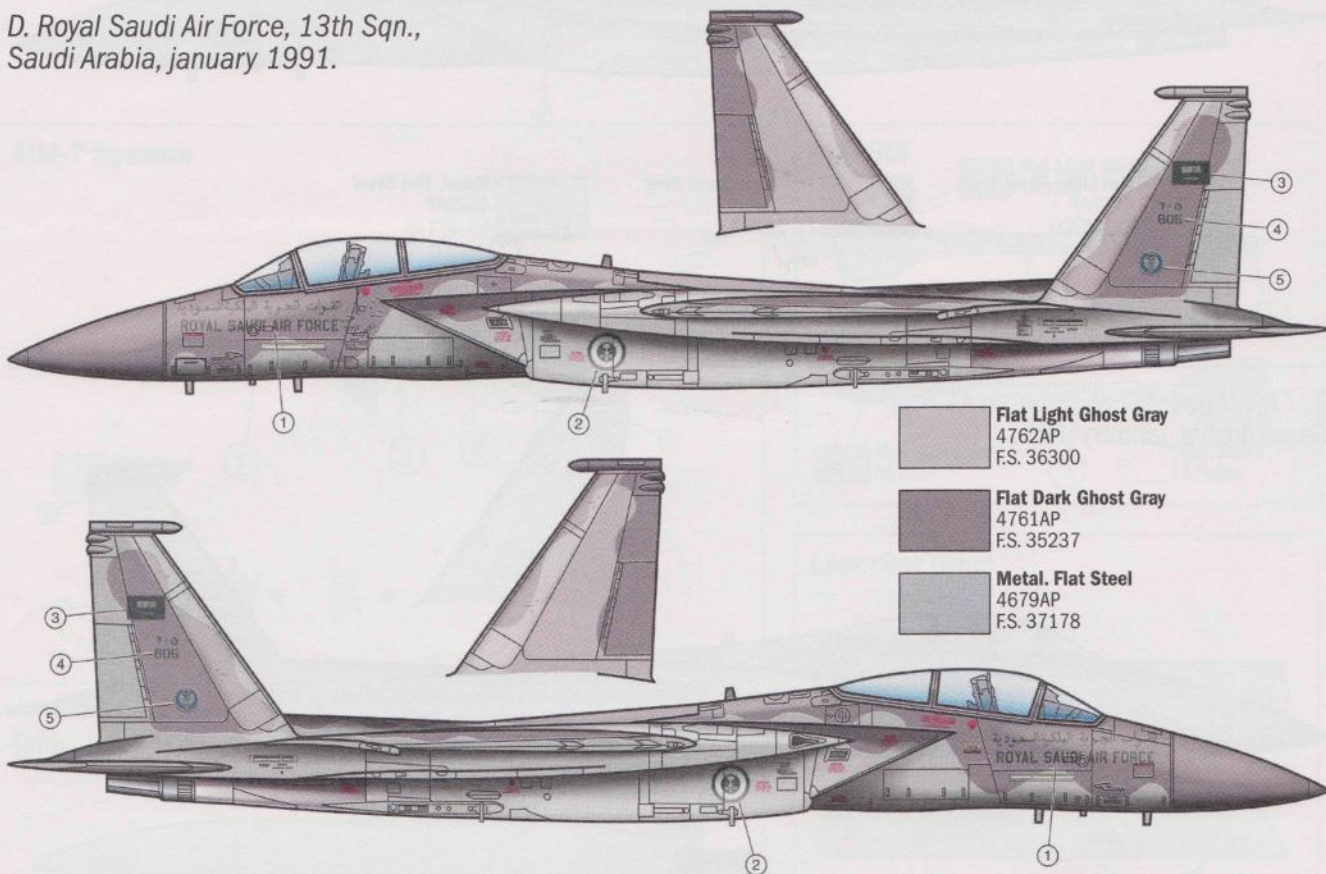

**KIT No 2763 Scale 1:48 - F-15C Eagle**

<p>NAME _____          NOMME _____          NAME _____          NOM _____          NOMBRE _____          NAAM _____</p> <p>TOWN _____          CITTA' _____          STADT _____          VILLE _____          CIUDAD _____          GEMEENTE _____</p>	<p>ADDRESS _____          INDIRIZZO _____          ADRESSE _____          DIRECTION _____          ADRES _____</p> <p>POSTAL CODE _____          C.A.P. _____          POSTALEITZAHL _____          CODE POSTALE _____          CODIGO POSTAL _____          POSTCODE _____</p> <p>COUNTRY _____          NAZIONE _____          LAND _____          PAYS _____          PAIS _____          LAND _____</p>
<p>DATE OF BIRTH _____          DATA DI NASCITA _____          GEBURTSDATUM _____          DATE DE NAISSANCE _____          NACIDO/A EL _____          GEBORRETEDATUM _____</p>	

**E-MAIL** \_\_\_\_\_

<p>DEFECTIVE PARTS          PARTI DIFETTOSE          DEFEKTE TEILE          PIECES DEFECTUEUSES          PIEZAS DEFECTUOSAS          DEFECTE ONDERDELEN</p>	<p>PLACE OF PURCHASE          ACQUISTATO PRESSO          ORT DES KAUFES          LIEU D'ACHAT          LUGAR DE COMPRA          PLAATS VAN AANKOOP</p> <p><input type="checkbox"/> Retail Store          Negozio          Einzelhandel          Detailliant          Detaillhandel</p> <p><input type="checkbox"/> Hyper Market          Grande Magazzino          Andere          Grande Surface          Gran Almacen          Hypermarket</p>
---	--

**ITALERI S.p.A.**  
 Via Pradazzo, 6/B  
 40012 - Calderara di Reno (BO) ITALY  
 fax: 0039 51 726 459  
 e-mail: italeri@italeri.com  
 www.italeri.com