



# 1:72 Nakajima B5N2 'Kate'

A04058 SCALE MODEL CONSTRUCTION KIT | Wingspan: 216mm Fuselage Length: 143mm | Two Decal Schemes Included | Two Build Options

**GB** The Nakajima B5N2 'Kate' was the most numerous Japanese torpedo bomber of the Second World War and while primarily operated as a torpedo bomber from carriers, it also saw service as a land based bomber. Although the 'Kate' was superior to its American torpedo bomber contemporaries it was still nearing obsolescence by the start of the war. A single engine monoplane, it was defended by just one rearward firing machine gun, operated by the radio operator, and its relatively low speed left it vulnerable to enemy aircraft. However it proved to be a devastatingly effective machine in skies not defended by enemy fighters, performing well at Pearl Harbour and going on to have success at the Battle of the Coral Sea and Midway. But as the war progressed, and its successor the B6N was delayed, the 'Kate' became ever more vulnerable and by the end of the war it was relegated to secondary roles.

**FR** Le Nakajima B5N2 surnommé 'Kate' était le bombardier-torpilleur japonais le plus répandu de la Deuxième Guerre mondiale. Il opérait principalement en tant qu'avion embarqué et était également utilisé comme bombardier basé à terre. Bien plus performant que ses concurrents américains, le Kate était déjà presque obsolète au début de la guerre. Avion monoplan monomoteur, son armement défensif ne consistait que d'une seule mitrailleuse orientée vers l'arrière et tirée par l'opérateur radio ; en outre, sa faible vitesse le laissait vulnérable aux attaques des avions ennemis. Il s'avéra toutefois être extrêmement performant lorsqu'il n'y avait pas de chasseurs opposants. Il connut de grandes victoires lors de l'attaque de Pearl Harbor et remporta des succès durant les batailles de la Mer de corail et de Midway. Mais au fur et à mesure que la guerre progressait, le retard de développement de son remplaçant le B6N rendit encore plus vulnérable le 'Kate' qui fut relégué à des rôles secondaires.

**DE** Die Nakajima B5N2 'Kate' war der zahlenmäßig größte japanische Torpedobomber des Zweiten Weltkrieges und wurde hauptsächlich als flugzeugträgergestützter Torpedobomber, aber auch als landgestützter Bomber eingesetzt. Obwohl die 'Kate' den damaligen amerikanischen Torpedobombern überlegen war, gehörte sie schon zu Kriegsbeginn fast zum alten Eisen. Als einmotoriger Eindecker bestand ihre einzige Verteidigung in einem nach hinten feuernenden, vom Bordfunker bedienten Maschinengewehr, und ihre verhältnismäßig niedrige Geschwindigkeit machte sie für Feindflugzeuge anfällig. Im nicht von feindlichen Jägern verteidigten Luftraum erwies sich sie jedoch als verheerend wirksame Maschine, die in Pearl Harbor gute Leistungen zeigte und in der Schlacht im Korallenmeer und der Schlacht von Midway erfolgreich war. Im weiteren Verlauf des Krieges, und weil ihre Nachfolgerin (die B6N) auf sich warten ließ, wurde die 'Kate' immer anfälliger und am Ende des Krieges mit zweitrangigen Aufgaben betraut.

**ES** El Nakajima B5N2, conocido como 'Kate' por los aliados, fue el más numeroso de los aviones torpederos japoneses de la Segunda Guerra Mundial y, aunque se utilizó principalmente como torpedero desde portaaviones, también entró en servicio como bombardero desde tierra. El 'Kate' era superior a los torpederos estadounidenses de la época, pero al comenzar la guerra ya estaba cerca de quedar obsoleto. Era un monoplano monomotor con una sola ametralladora dirigida hacia atrás, a cargo del operador de radio, y su velocidad, relativamente baja, lo hacía vulnerable a los aviones enemigos. Sin embargo, demostró tener una devastadora eficacia cuando los cielos estaban libres de cazas enemigos, con buenos resultados en Pearl Harbor y llegando a obtener importantes éxitos en las batallas del Mar de Coral y Midway. Pero, a medida que avanzaba la guerra y se retrasaba la introducción del nuevo B6N, el 'Kate' resultó cada vez más vulnerable, y al final del conflicto había quedado relevado a funciones secundarias.

**SE** Nakajima B5N2, eller "Kate", var det japanska torpedbombplan som användes i flest antal under andra världskriget. Det flög i huvudsak som torpedplan från hangarfartyg, men användes även som landbaserat bombplan. Trots att "Kate" inledningsvis hade övertagit över sina amerikanska motsvarigheter närmade det sig slutet på sin tjänstgöringstid vid krigets inledningskede. Det var ett enmotorigt monoplan som endast försvarades av en bakåtriktad kulspruta som radiooperatören skötte, samtidigt som planets relativt låga hastighet resulterade i en sårbarhet för fiendeeld. Det visade sig dock vara en mycket effektiv maskin i luftrum som inte förvarades av fiendeplan och gjorde väl i från sig över Pearl Harbour och senare i slagen om Korallhavet och Midway. Men i takt med att kriget fortgick, och efter att efterföljaren B6N hade försenats, blev "Kate" ännu mer sårbar och gavs sekundära roller i krigets slutkede.

### Specification

Maximum Speed: 235 mph (378km/h)

Range: 1,237 miles (1,992 km)

Wingspan: 50 ft 11 in (15.52m)

Length: 33 ft 9.0 in (10.30m)

Armament: 1 x 7.7mm machine gun and either 1 x 800kg Torpedo or up to 800 kg (1,760lb) of bombs

### Spécification:

Vitesse maximale: 378 km/h

Autonomie: 1.992 km avec carburant maximum

Envergure: 15,52 m

Longueur: 10,30 m

Armement: une mitrailleuse de 7,7 mm et une torpille de 800 kg alternativement jusqu'à 800 kg de bombes

### Spezifikation:

Höchstgeschwindigkeit: 378 km/h

Reichweite: 1.992 km mit maximaler Treibstoffzuladung

Spannweite: 15,52 m

Länge: 10,30 m

Bewaffnung: 1 Maschinengewehr 7,7 mm und entweder 1 Torpedo 800 kg oder bis zu 800 kg an Bomben

### Especificación:

Velocidad máxima: 378 km/h

Autonomía: 1992 km con carga máxima de combustible

Envergadura: 15,52 m

Longitud: 10,30 m

Armamento: 1 ametralladora de 7,7 mm y 1 torpedo de 800 kg o hasta 800 kg de bombas

### Spekifikation:

Maximal hastighet: 378 km/h

Räckvidd: 1992 km med full tank

Spännvidd: 15,52 m

Längd: 10,30 m

Bestyckning: en 7,7 mm-kulspruta och antingen en 800 kg-torped eller upp till 800 kg bomber

Airfix would like to thank the Wings Museum (<http://www.wingsmuseum.co.uk/>), Giuseppe "Joe" Picarella, and Nick Millman of <http://www.aviationofjapan.com/blog> for their excellent assistance with this project.

**HORNBY  
HOBBIES**

### FOR BEST RESULTS:

Surfaces to be painted should be clean — before parts are removed from the sprue, wash in warm, soapy water, rinse and dry thoroughly. Stir paints thoroughly before use.

### PLEASE NOTE:

Some parts in the kit may not be required to build the model specified.



# ASSEMBLY INSTRUCTIONS

**GB** Study drawings and practice assembly before cementing parts together. Carefully scrape plating and paint from cementing surfaces. All parts are numbered. Paint small parts before assembly. To apply decals cut sheet as required, dip in warm water for a few seconds, slide off backing into position shown. Use in conjunction with box artwork. Not appropriate for children under 36 months of age, due to the presence of small detachable parts.

**FR** Étudier attentivement les dessins et simuler l'assemblage avant de coller les pièces. Gratter soigneusement tout revêtement ou peinture sur les surfaces à coller avant collage. Toutes les pièces sont numérotées. Peindre les petites pièces avant l'assemblage. Pour coller les décalques, découper le motif, le plonger quelques secondes dans de l'eau chaude puis le poser à l'endroit indiqué en décollant le support papier. Utiliser en même temps les illustrations sur la boîte. Ne convient pas à un enfant de moins de 36 mois - présence de petits éléments détachables.

**DE** Vor Verwendung des Klebers Zeichnungen studieren und Zusammenbau üben. Farbe und Plattierung vorsichtig von den Klebeflächen abkratzen. Alle Teile sind nummeriert. Vor Zusammenbau kleine Teile anmalen. Um die Abziehbilder aufzukleben, diese ausschneiden, kurz in warmes Wasser tauchen, dann abziehen und wie abgebildet aufkleben. In Verbindung mit Abbildungen auf Schachtel verwenden. Ungeeignet für Kinder unter 36 Monaten. Kleine Teilchen vorhanden die sich lösen können.

**ES** Estudiar los dibujos y practicar el montaje antes de pegar las piezas. Raspar cuidadosamente el plateado y la pintura en las superficies de contacto antes de pegar las piezas. Todas las piezas están numeradas. Es conveniente pintar las piezas pequeñas antes de su montaje. Para aplicar las calcomanías, cortar la hoja, sumergir en agua tibia durante unos segundos y deslizarlas en la posición debida. Ver ilustraciones en la caja. No conviene a un niño menor de 36 meses, contiene pequeñas piezas que pueden soltarse.

**SE** Studera bilderna noggrant och sätt ihop delarna innan du limmar ihop dem. Skrapa noggrant bort förtäckning och färg från limmade delar. Alla delarna är nummerade. Mala smadelarna före ihopsättning. Fastsättning av dekaler, klipp ark. Doppa i varmt vatten några sekunder, lat baksidan glida på plats som bilden visar. Används i samband med kartongens handlitografi. Rekommenderas ej för barn under 3 år. Innehåller löstagbara smadelar.

**IT** Studiare i disegni e praticare il montaggio prima di unire insieme i pezzi con l'adesivo. Raschiare attentamente le tracce di smalto e cromatura dalle superfici da unire con adesivo. Tutti i pezzi sono numerati. Colorare i pezzi di piccole dimensioni prima di montarli. Per applicare le decalcomanie, tagliare il foglio secondo il caso, immergere in acqua calda per alcuni secondi, quindi sfilare la decalcomania dalla carta di supporto e piazzarla nella posizione indicata. Usare in congiunzione con l'illustrazione sulla scatola. Non adatto ad un bambino di età inferiore ai 36 mesi dovuto alla presenza di piccoli elementi staccabili.

**NL** Tekeningen bestuderen en delen in elkaar zetten alvorens deze te lijmen. Metaalcoating en lak voorzichtig van lijmvlakken af schrapen. Alle delen zijn genummerd. Kleine delen vóór montage verven. Voor aanbrengen van stickers, gewenste stickers uit vel knippen, een paar seconden in warm water dompelen en dan van schutblad af op afgebeelde plaats schuiven. Hierbij afbeelding op doos raadplegen. Niet geschikt voor kinderen onder 3 jaar, omdat kleine deeltjes gemakkelijk kunnen losraken.

**DK** Tegningerne bør studeres, og man bør øve sig i monteringen, før delene limes sammen. Pladestykker og maling skal omhyggeligt fjernes fra kloebeoverfladerne. Alle dele er nummererede. Små dele skal males før monteringen. Overføringsbillederne anvendes ved at tilklippe arket efter behov. Og dyppe det i varmt vand i nogle få sekunder. Underlaget glides af og anbringes i den viste position. Påføres ifølge brugsanvisningerne på oesken. Ikke til børn under 3 år, forekomst af små løse elementer.













**PT** Estudar atentamente os desenhos e experimentar a montagem. Raspar cuidadosamente as superfícies de modo a eliminar pintura e revestimento antes de colar. Todas as peças estão numeradas. Pintar as pequenas peças antes de colar. Para aplicar as decalcomanias, cortar as folhas e mergulhar em água morna por alguns segundos, depois deslizar e aplicar no respectivo lugar, como indicado nas ilustrações na caixa. Não convém a uma criança de menos de 36 meses devido à presença de pequenos elementos destacáveis.

**FI** Tutustu piirroksiin ja harjoittele kokoamista ennen kuin liimaat osat yhteen. Raaputa metallipäällyste ja maali varovasti pois liimattavilta pinoilta. Kaikki osat on numeroitu. Maalaa pienet osat ennen kokoamista. Siirtokuvien kiinnittämiseksi leikkaa ne arkista tarpeen mukaan. Kasta kuva lämpimään veteen muutaman sekunnin ajaksi, anna takapuolen liukua kuvalle osoitettuun kohtaan. Käytetään yhdessä laatikon kuvituksen kanssa. Ei suositella alle kolmivuotiaille lapsille. Paljon irrotettavia pikkuosia.

**PL** Przed przystąpieniem do sklejania przestudiuj uważnie rysunki i przećwicz składowanie części. Osłóźnie zeskrób ze sklepanych powierzchni powłokę i farbę. Wszystkie części są ponumerowane. Drobnie części pomaluj przed ich złożeniem. Celem przeniesienia odbitki wytnij ją z arkusza, zanurz na kilka sekund w letniej wodzie i zsuń z podłoża na wymagane miejsce. Używaj w połączeniu ze wzorami na pudełku. W związku z obecnością wielu drobnych, rozbiernych części, nie stosowne dla dzieci poniżej 3 lat.

**GR** Μελετήστε προσεκτικά τα σχέδια και συναρμολογήστε για πρώτη φορά τα κομμάτια χωρίς να τα συγκολλήσετε. Αφαιρέστε επιμελώς τη μεταλλική μπιονιά και την πλαστική βαφή από τις επιφάνειες τις οποίες θα συγκολλήσετε ζυμώντας τις προσεκτικά. Όλα τα κομμάτια είναι αριθμημένα. Χρωματίστε τα μικρά κομμάτια πριν από τη συναρμολόγηση. Για να κολλήσετε τις χαλκομανίες, κόψτε γύρω από το σχέδιο όπως απαιτείται, βυθίστε το μερικά δευτερόλεπτα σε χλιαρό νερό και μετά τοποθετήστε το στη θέση που υποδεικνύεται, αφαιρώντας τη μεμβράνη που το καλύπτει. Λάβετε υπόψη σας ταυτόχρονα την εικονογράφηση του κουτιού. Ακατάλληλο για παιδιά ηλικίας κάτω των 36 μηνών λόγω ύπαρξης μικρών κομματιών που αποσπώνται.

## ASSEMBLY ICON INSTRUCTIONS

<p>Assembly phase Phase de montage Montagephase Fase de montaje Monteringsfasen Fase di montaggio Montagefase Fase de montagem Monteringsfase Kokamisvaihe Faza składowania Φάση συναρμολόγησης</p> 	<p>Cement Coller Kleben Pegar Limma Incollare Lijmen Colar Klebes Limmaa Kleić Συγκολλήστε</p> 	<p>Do not cement together No pas coller Nicht kleben No pegar Limma inte Non incollare Niet lijmen Não colar Skal ikke klebes Älä limmaa Nie kleić Μη συγκολλήσετε</p> 	<p>Indicates final location Indique l'emplacement final Zeigt Endposition Indica la ubicación definitiva Anger slutmonteringsplats Sede di montaggio finale Geeft uiteindelijke locatie aan 'Indica localização final Viser endelig placering Osoittaa lopullisen sijainnin Oznacza miejsce docelowe Υποδεικνύει τελική τοποθεσία</p> 	<p>Alternative part(s) provided Autre(s) pièce(s) fournie(s) Ersatzteil(e) mitgeliefert Se incluye(n) pieza(s) alternativa(s) Alternativ(a) del(ar) ingår Uno o più componenti alternativi forniti Alternatieve onderdelen meegeleverd Peça(s) alternativa(s) fornecida(s) Alternativ(e) del(e) medfølger Vaihtoehtoiset osat pakkauksessa Dostępne części zamiennie Παρέχονται εναλλακτικά κομμάτια</p> 	<p>Repeat this operation Répéter l'opération Vorgang wiederholen Repetir la operación Upprepa åtgärden Ripetere l'operazione De verrichting herhalen Repetir a operação Manövern gentages Toista toimenpite Powtórzć operację Επανάλαβε τη διαδικασία</p> 	
<p>Decals Decalcomanías Abziehbild Calcomanias Dekaler Decalcomanie Stickers Decalcomania Billedoverføring Siirtokuvat Kalkomanie Χαλκομανίες</p> 	<p>Crystal part Pièce cristal Kristallteil Pieza de cristal Kristallid Pezzo cristallo Kristallen onderdeel Peça de cristal Kryształowy Krystalliosa Część kryształowa Κομμάτι κρυστάλλου</p> 	<p>Weight Laster Beschweren Lastrar Belasta Aplicare un peso Verzwaren Lastrar Påfør vægt Aseta vastapaino Obciążyć balastem Επιθέστε βάρος</p> 	<p>Remove by filing Enlever avec une lime Abfeilen Eliminar con lima Ta bort genom att fila Rinnuovere con la lima Verwijderen door afvijlen Remove limando Fjern ved at file væk Poista viilaamalla Usunąć przy użyciu pilnika Αφαιρέστε λιμάροντας με λίμα</p> 	<p>Drill or pierce Percer Durchbohren Perforar Borra Trapanare o forare Boren of doorboren Furar Gennembor Poraa tai puhkaise Wywiercić lub przedziurawić Τρυπήστε</p> 	<p>Cut Découper Schneiden Cortar Skär Tagliare Snijden Cortar Skzar Leikkaa Przeciąć Κόψτε</p> 	<p>Humbrol paint number No peinture Humbrol Humbrol-Farbrnummer No de pintura Humbrol Humbrol färg nummer No vernice Humbrol Humbrol verfnummer No de pintura Humbrol Humbrol malingsnummer Humbrol-maaln numero Nr farby Humbrol Νούμερο χρώματος Humbrol</p> 

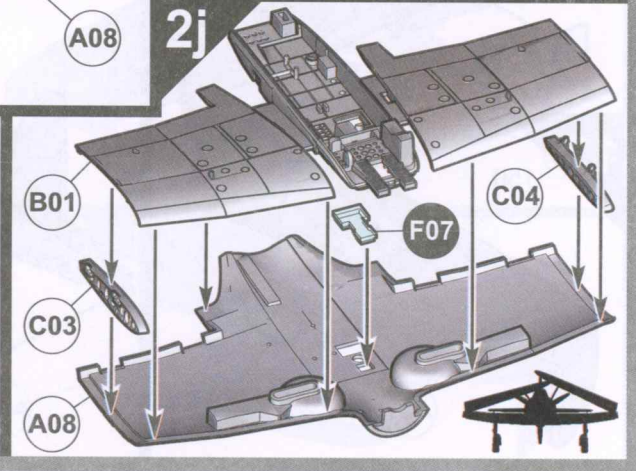
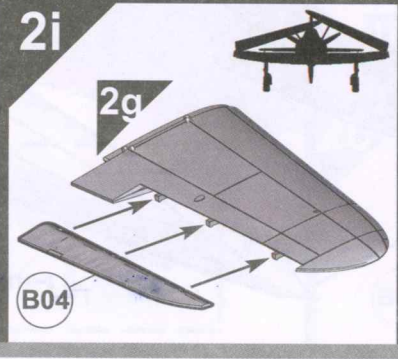
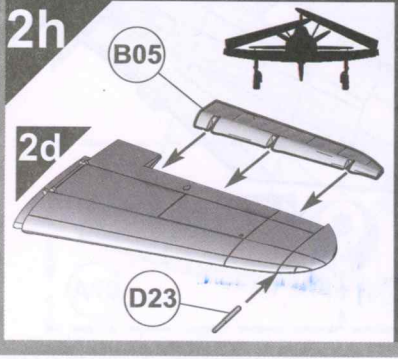
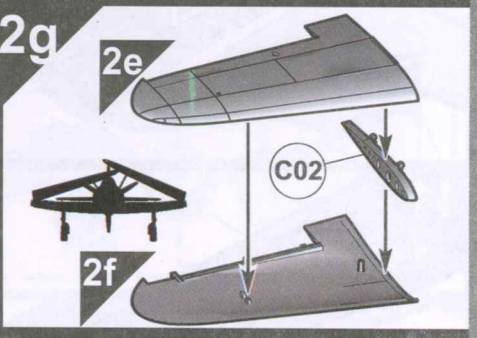
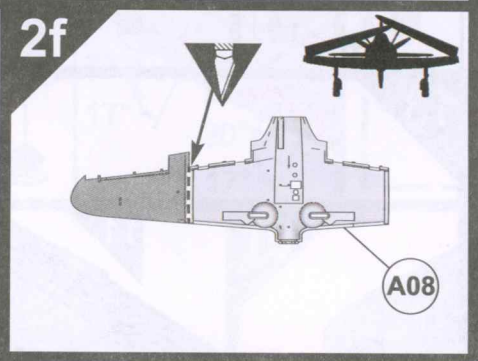
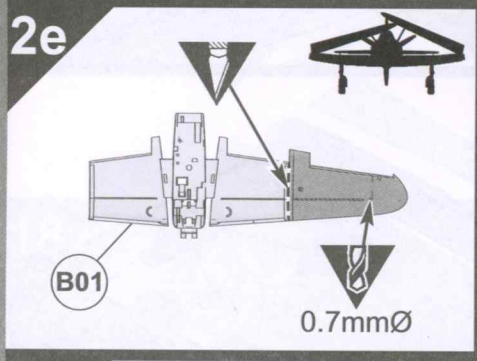
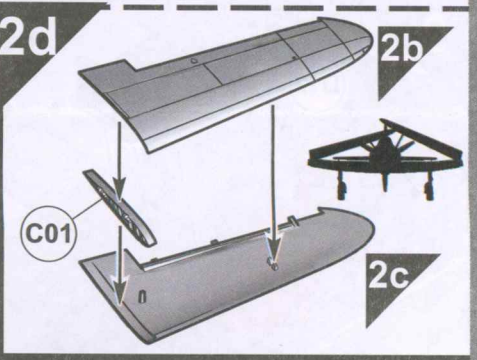
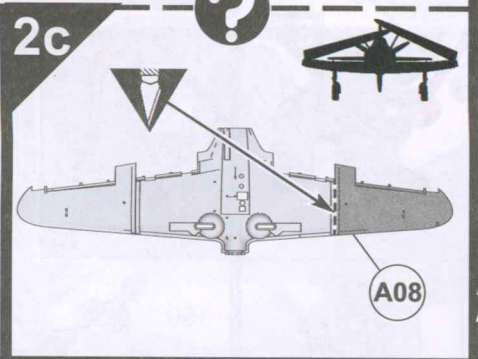
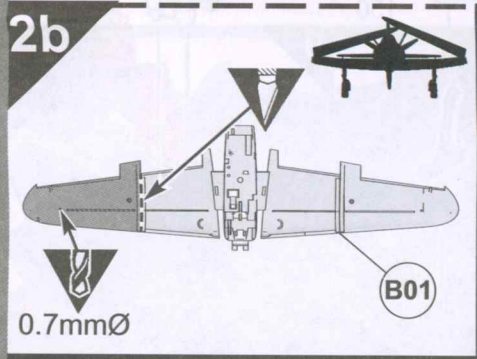
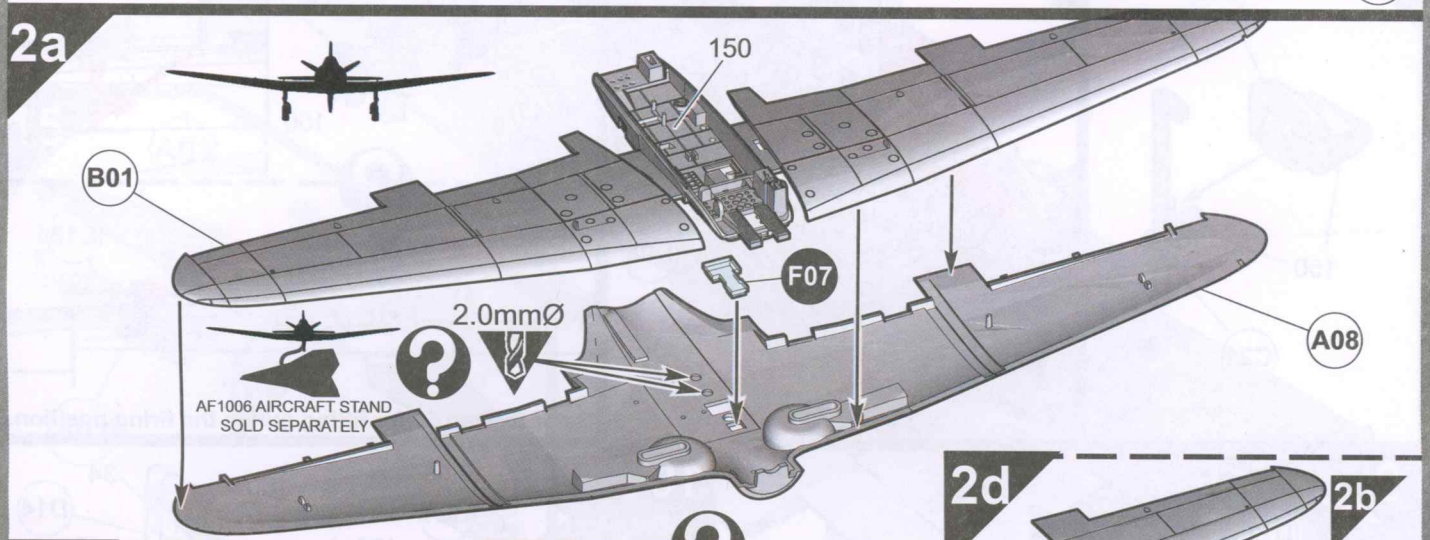
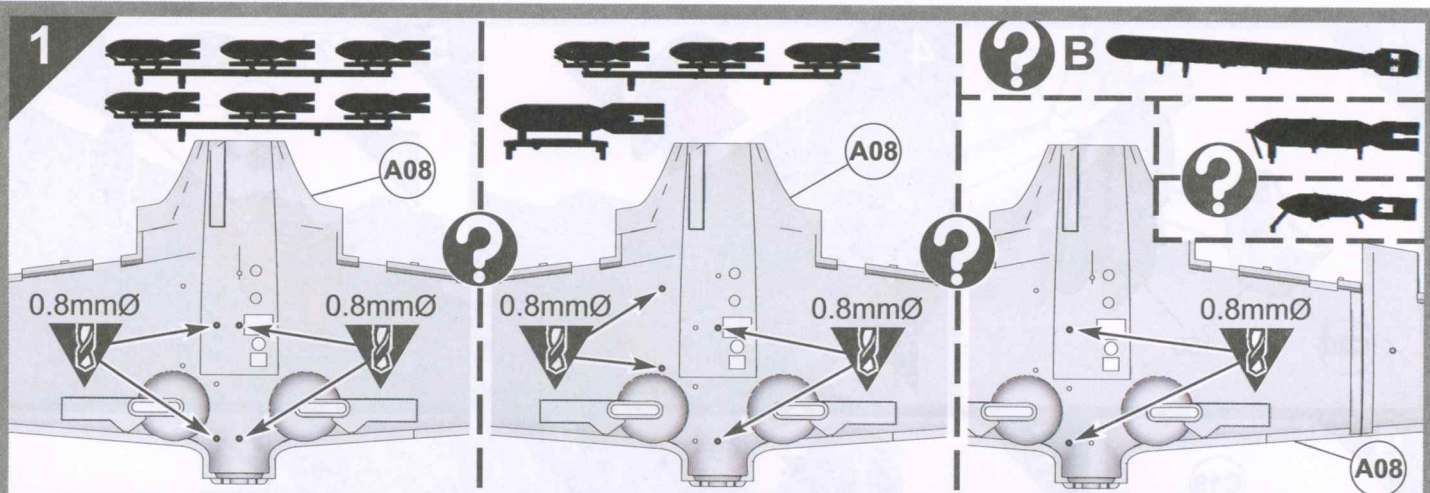

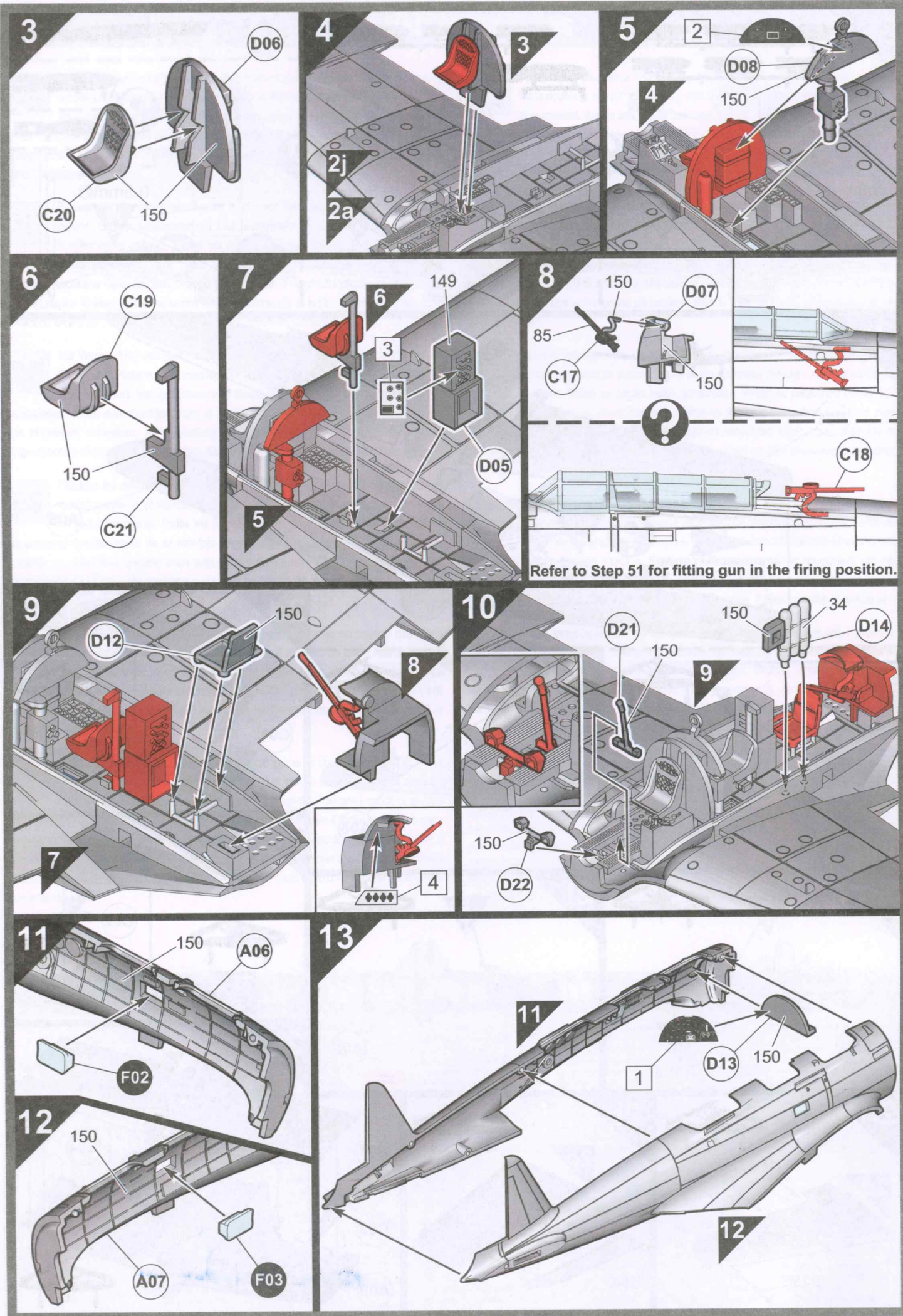

14

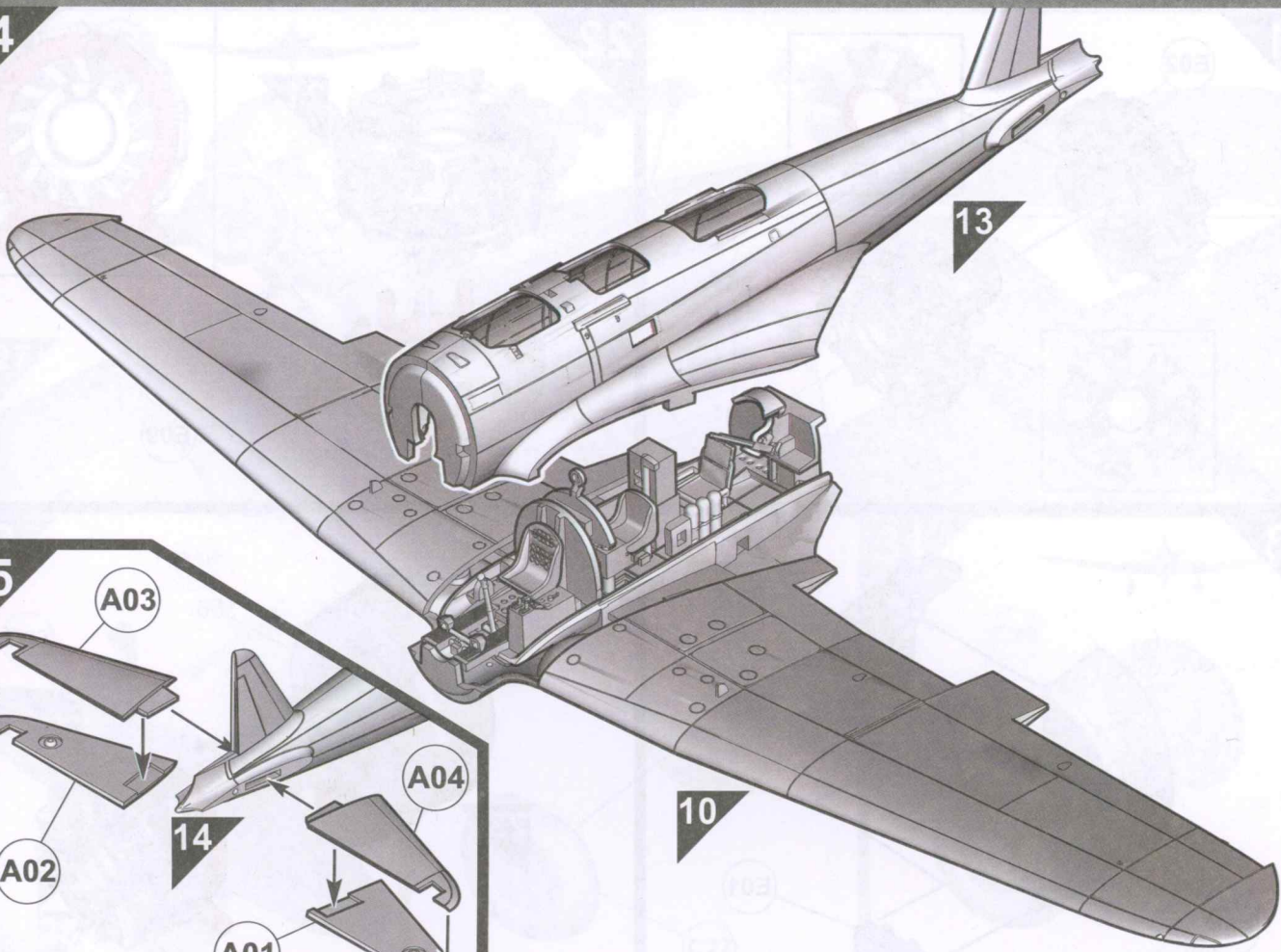

15

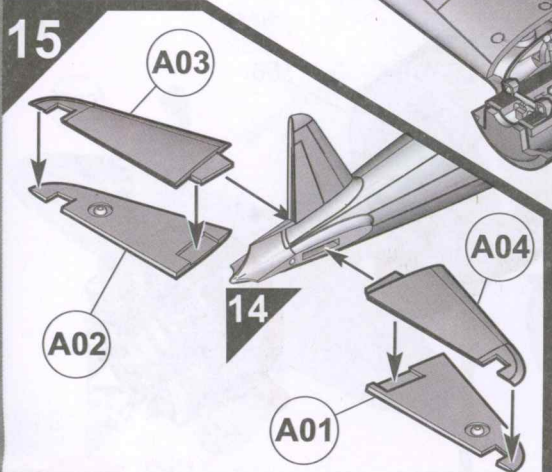

16

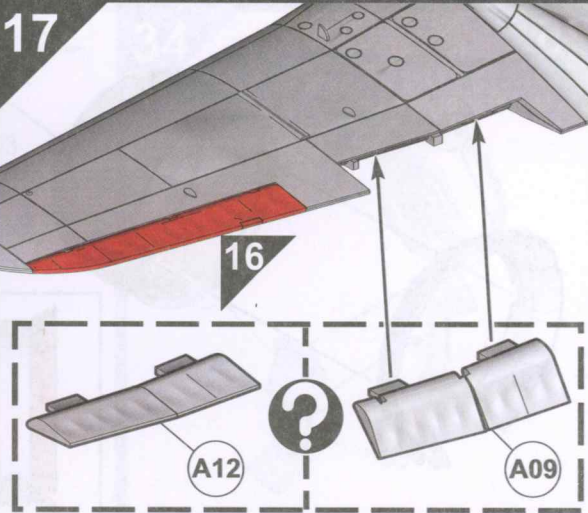
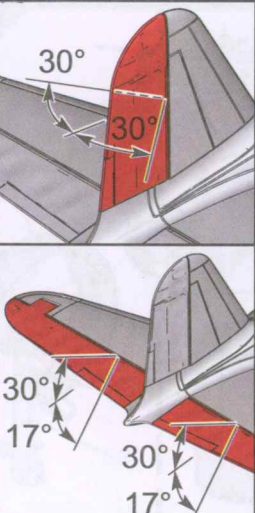
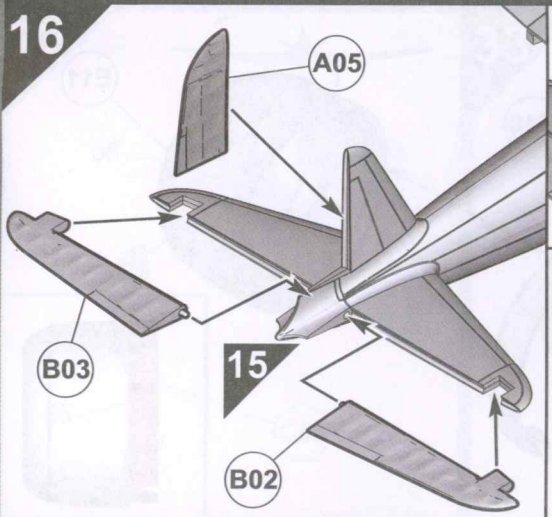

18

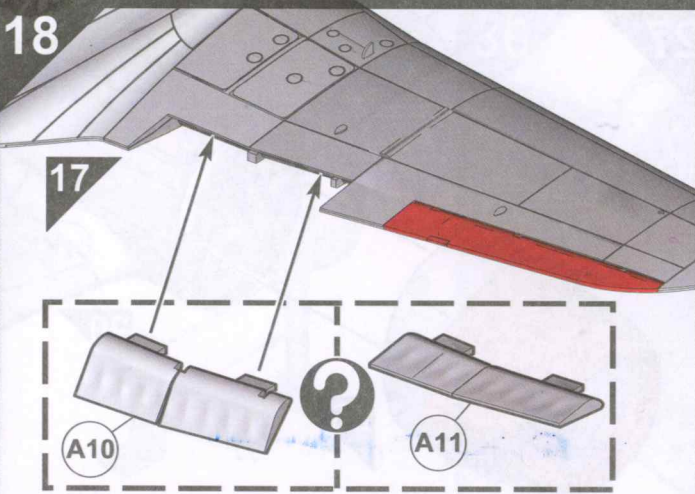

19

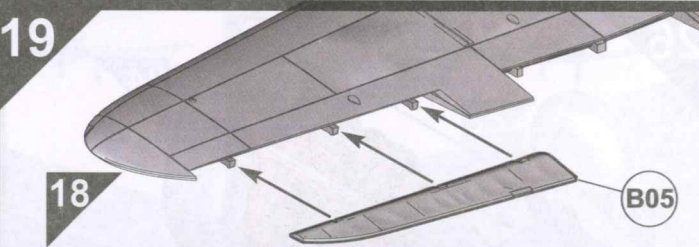

20

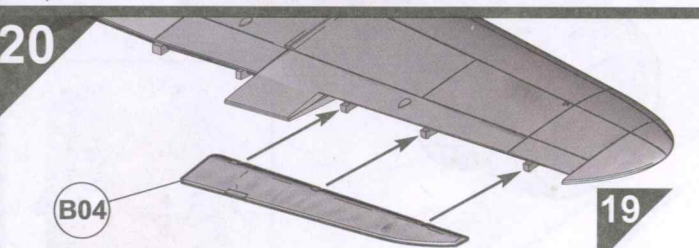

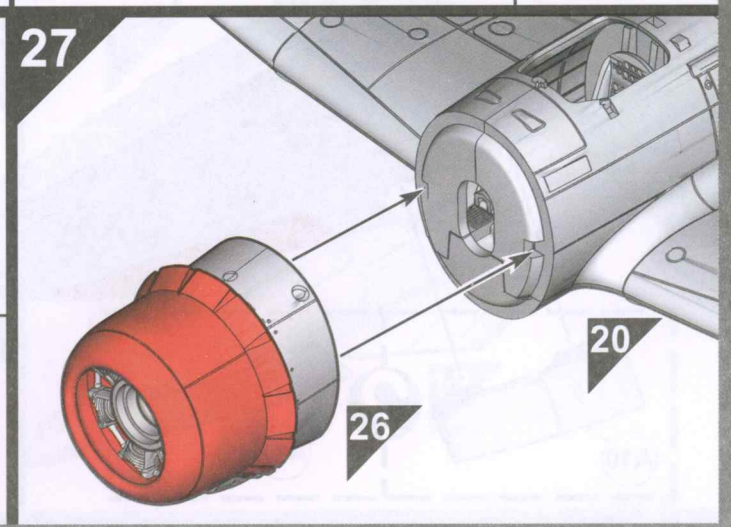
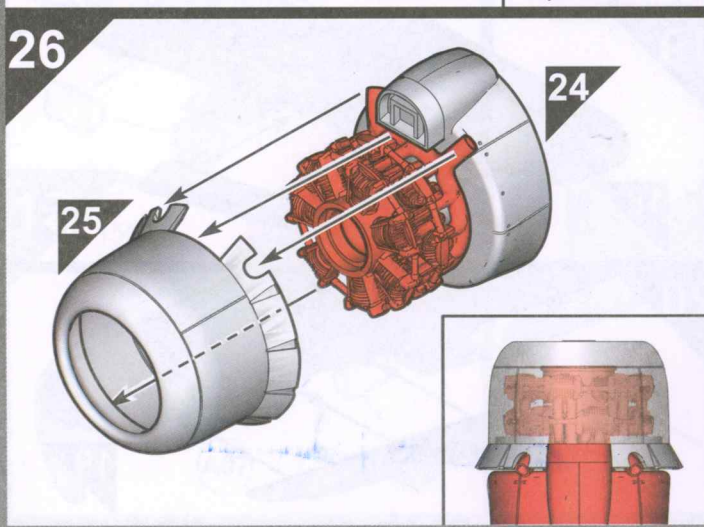
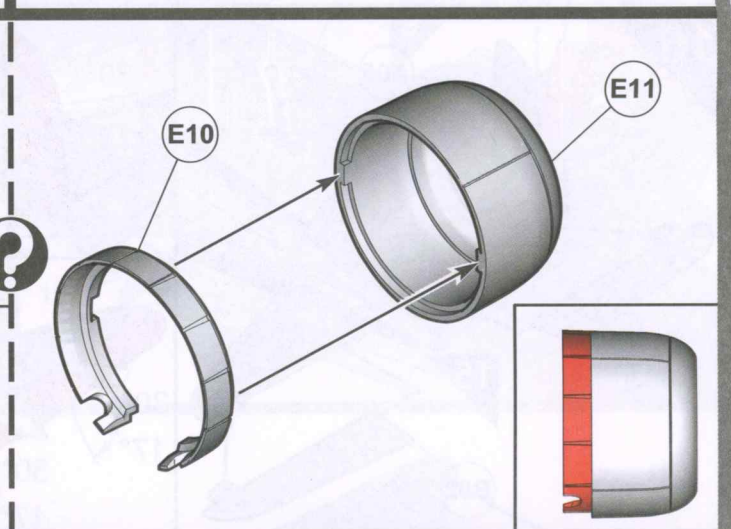
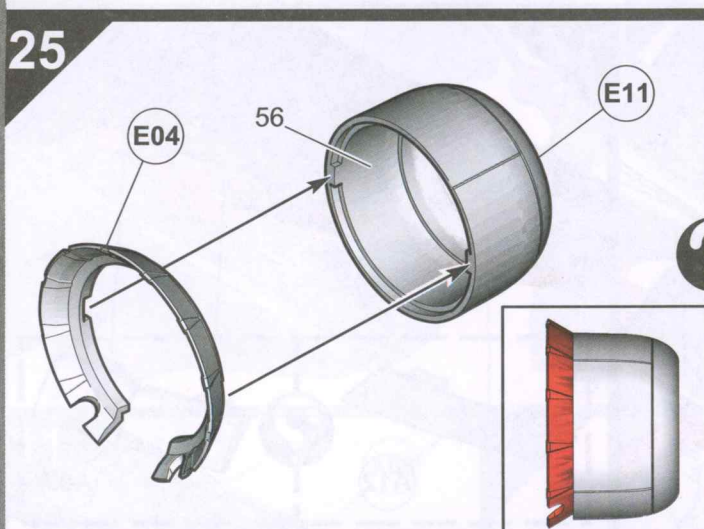
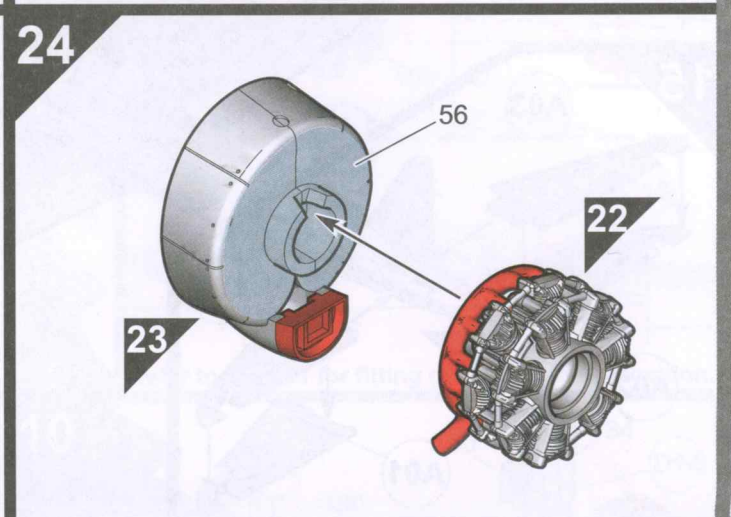
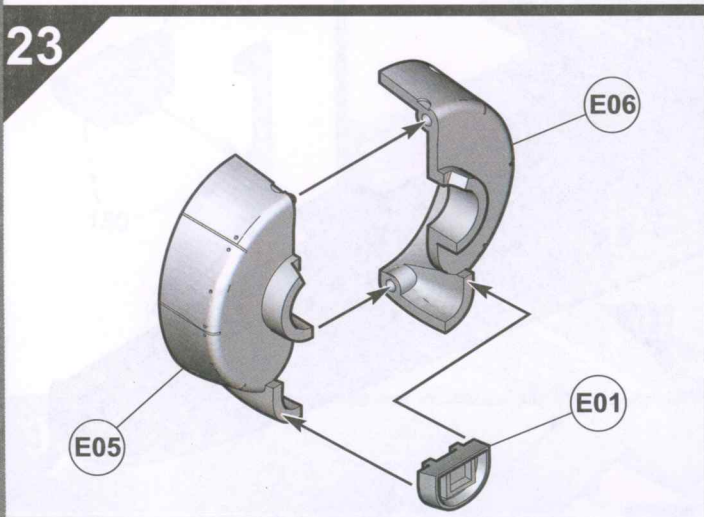
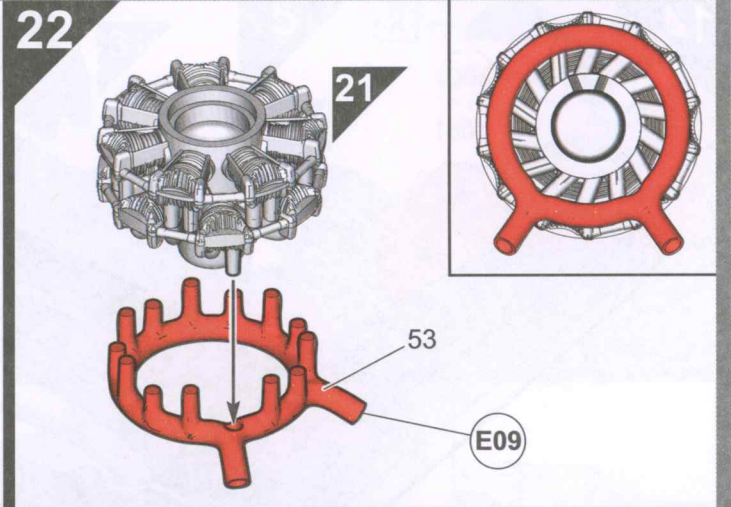
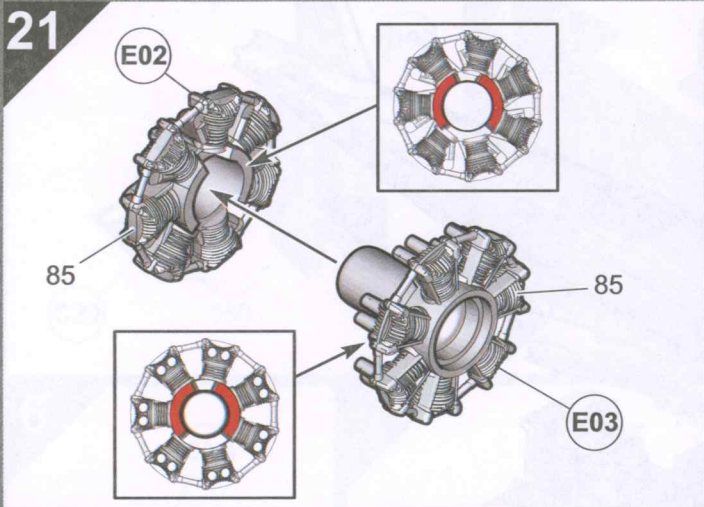

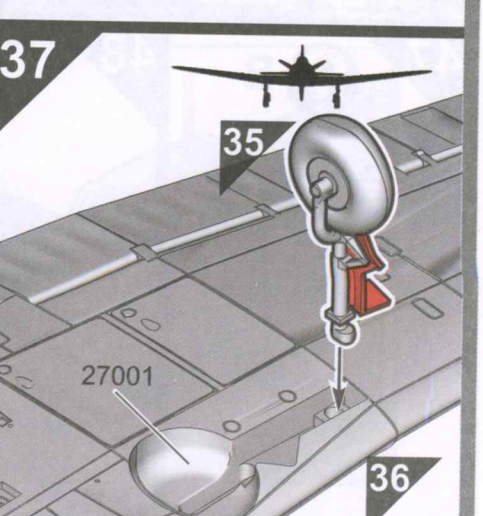
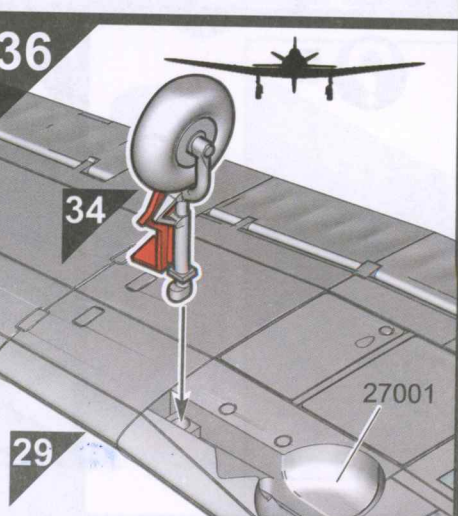
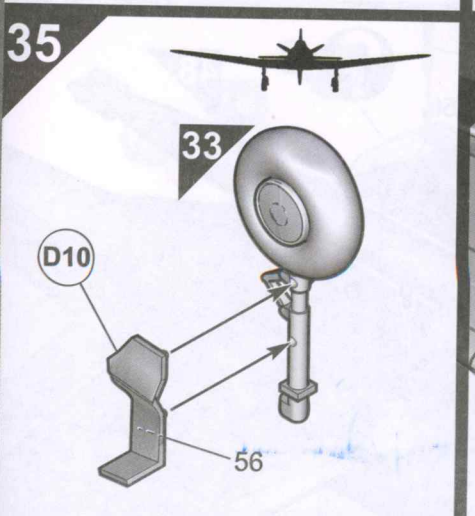
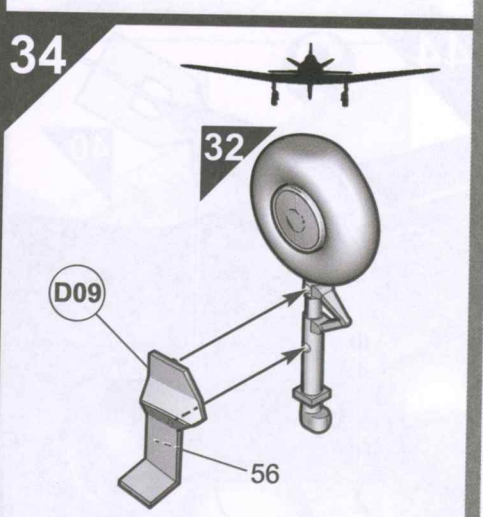
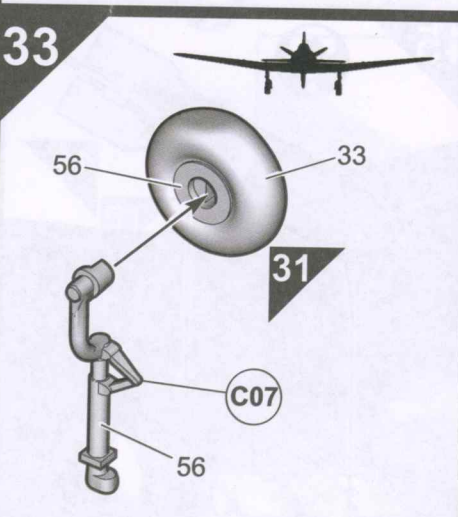
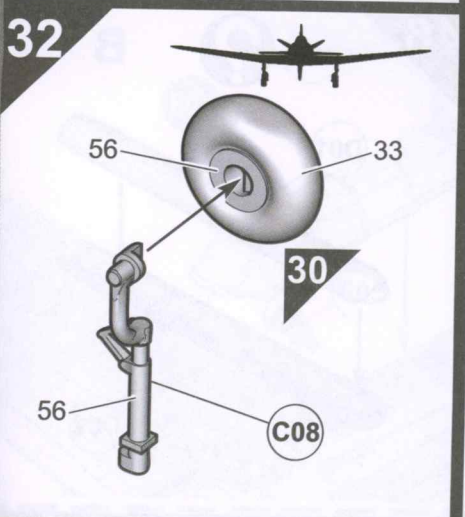
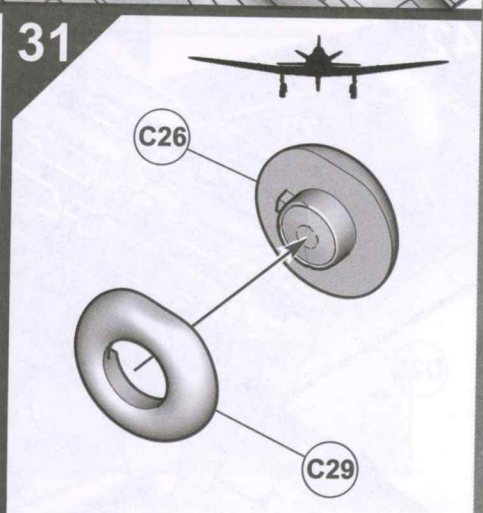
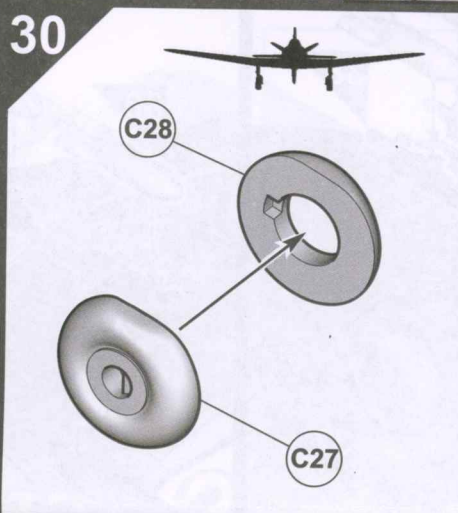
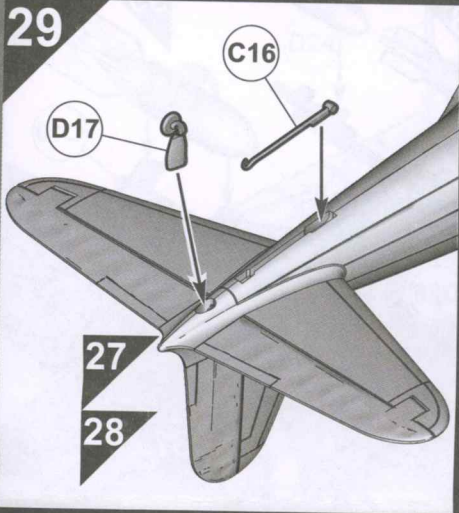
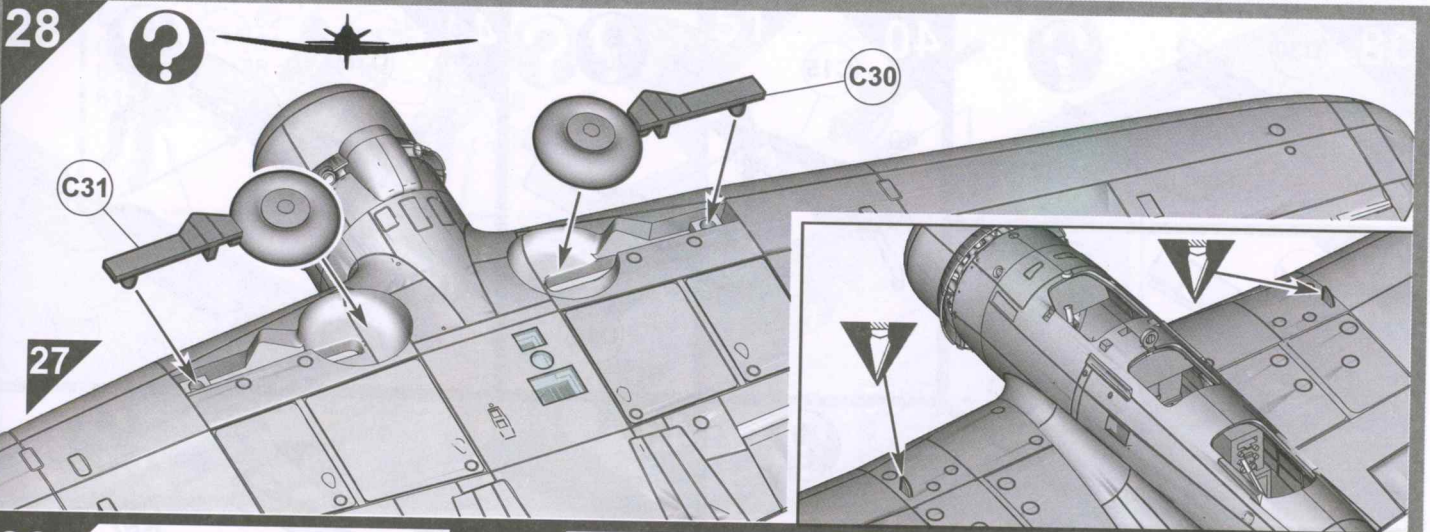

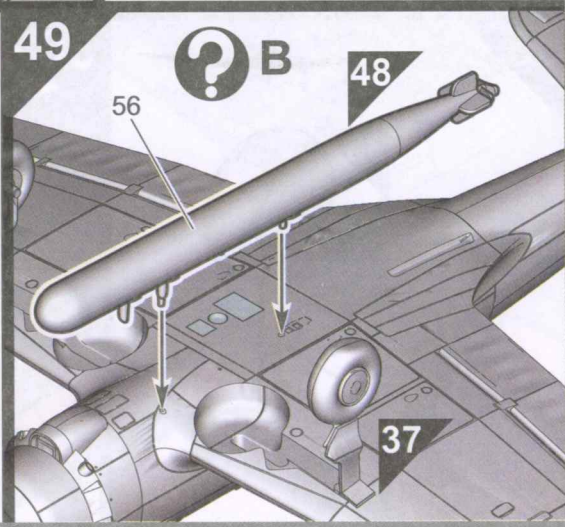
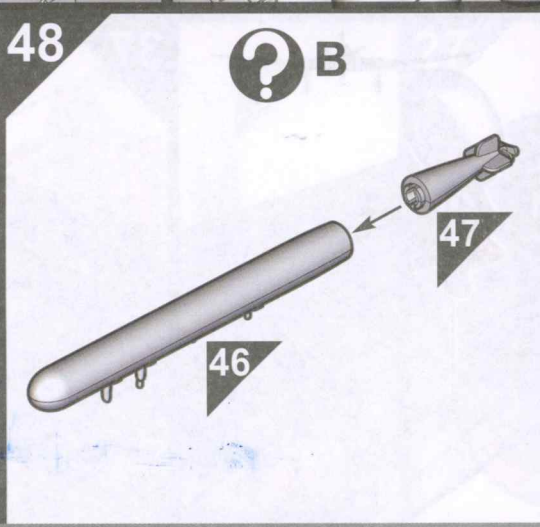
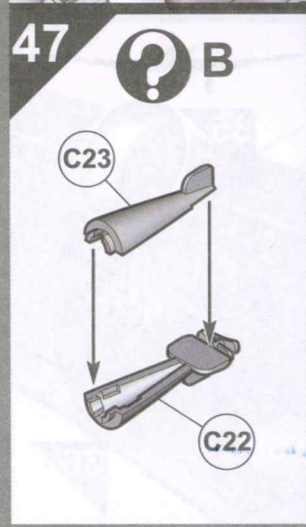
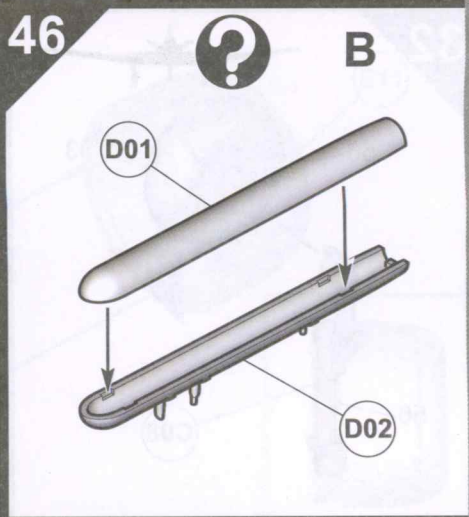
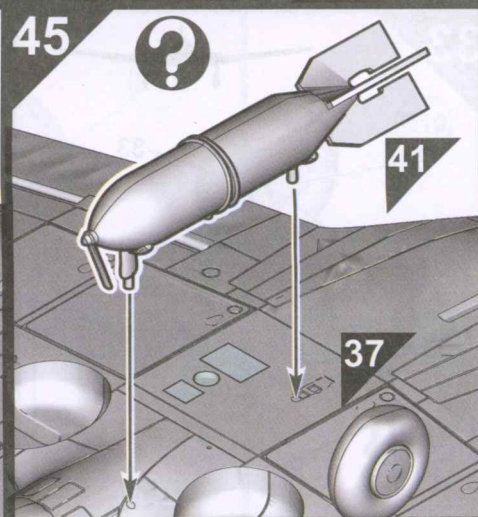
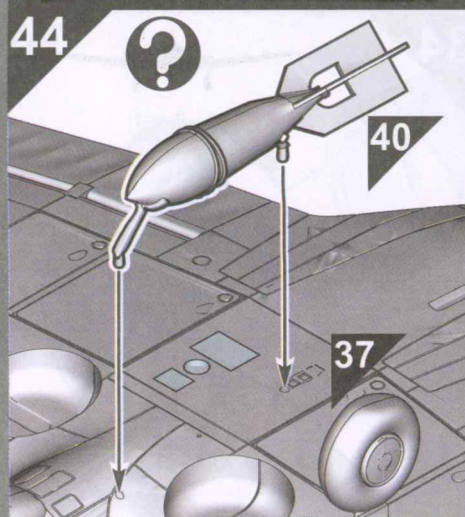
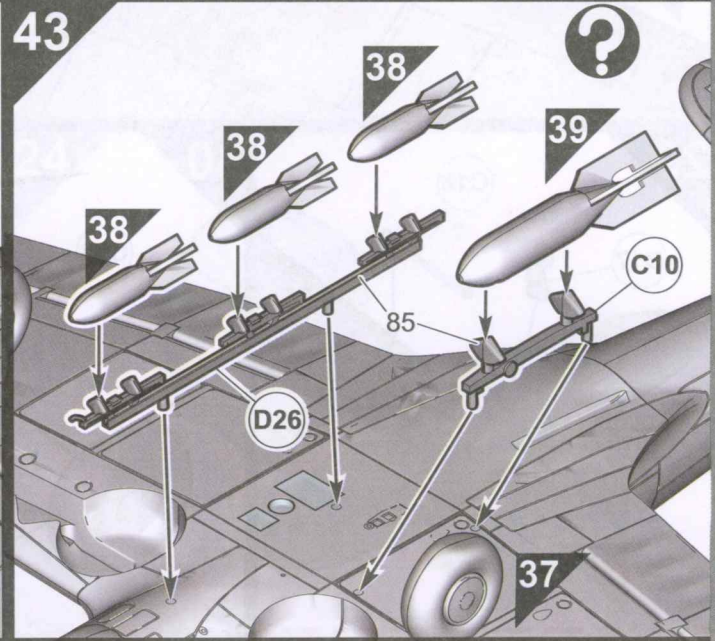
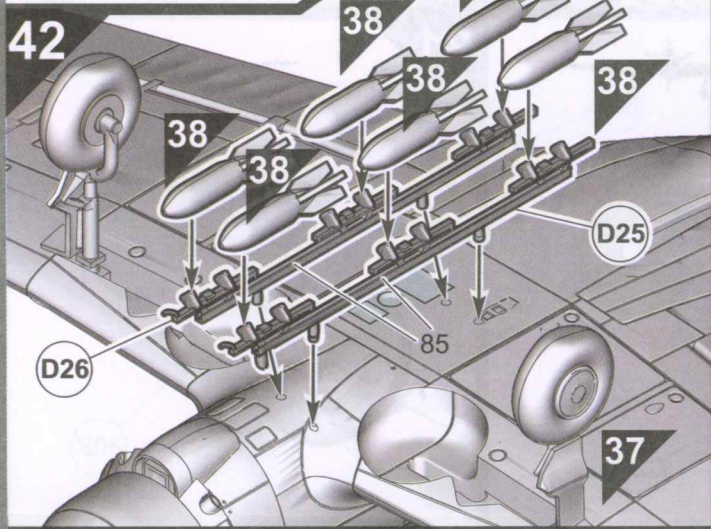
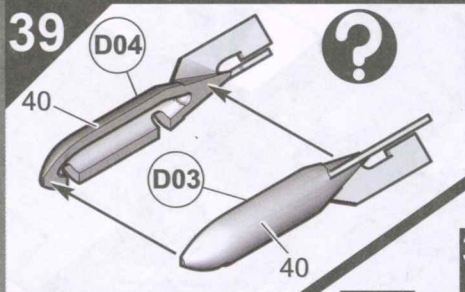
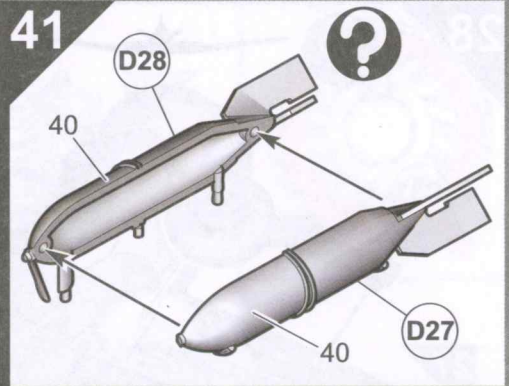
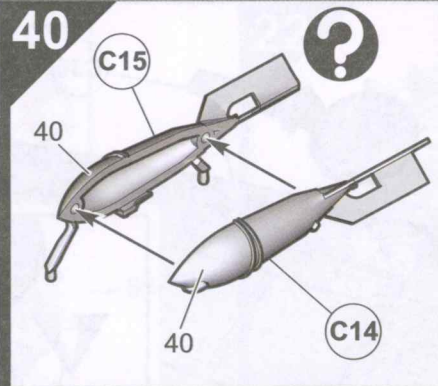
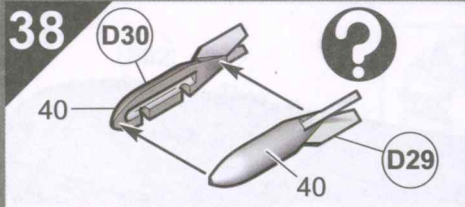



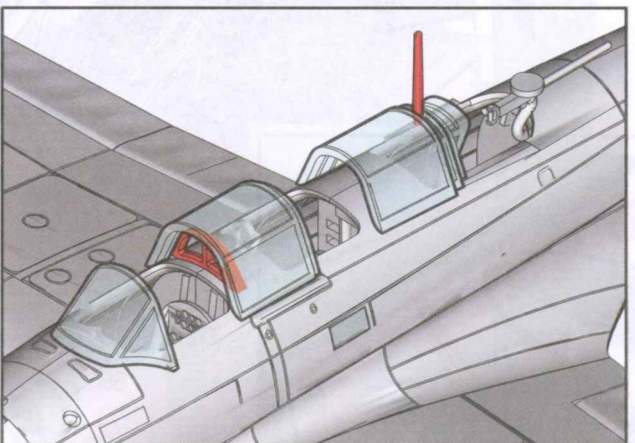
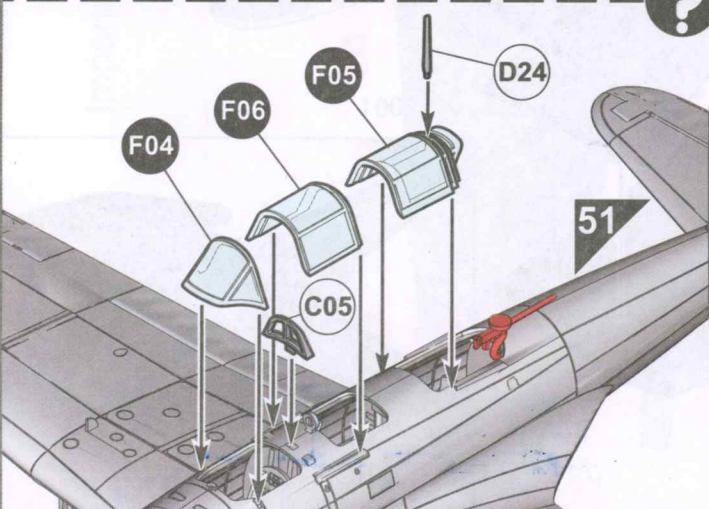
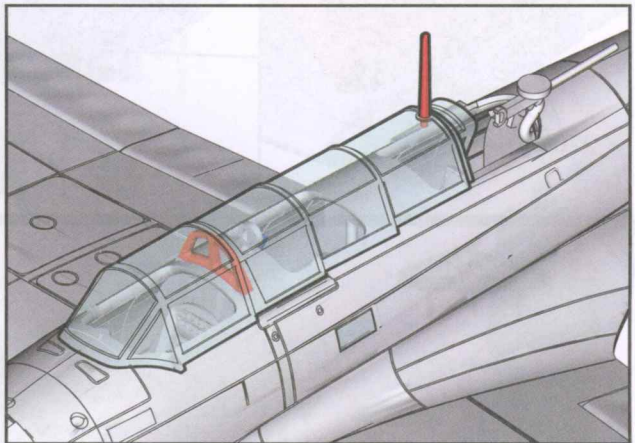
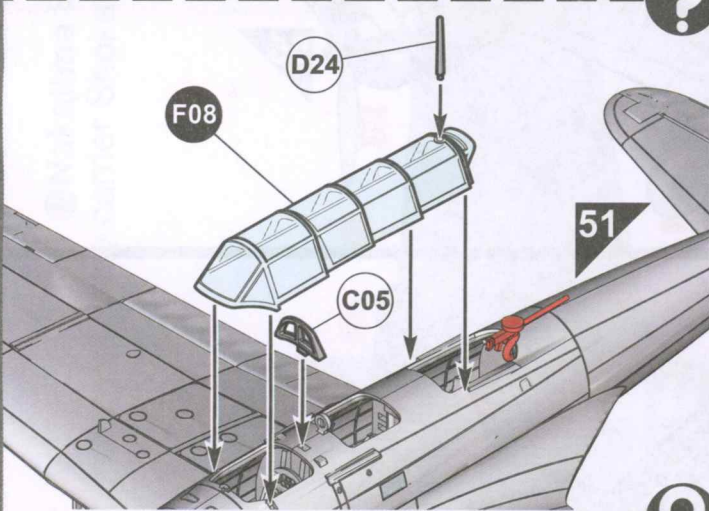
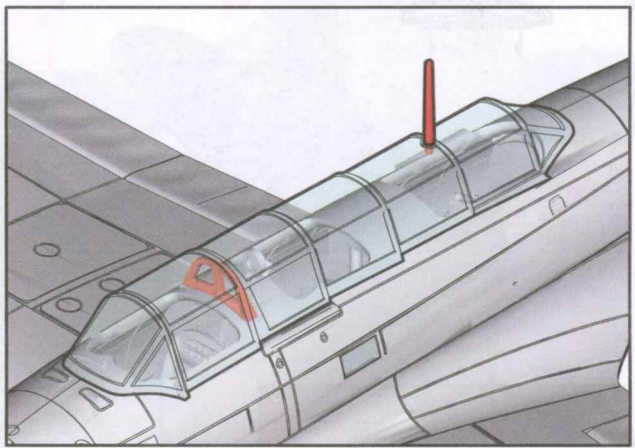
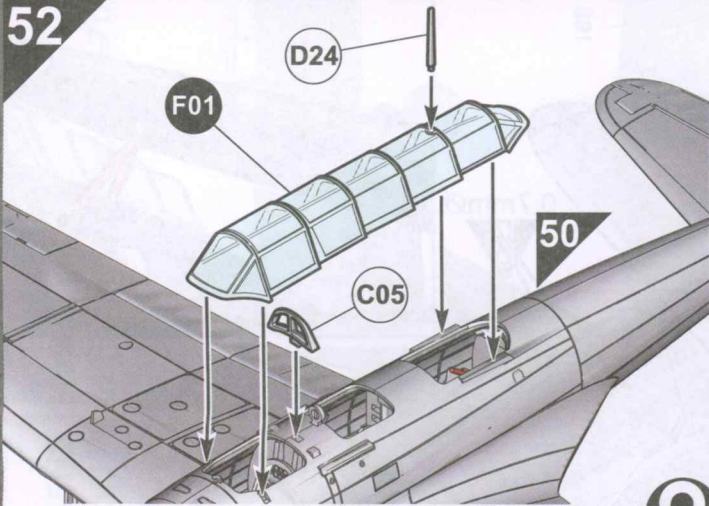
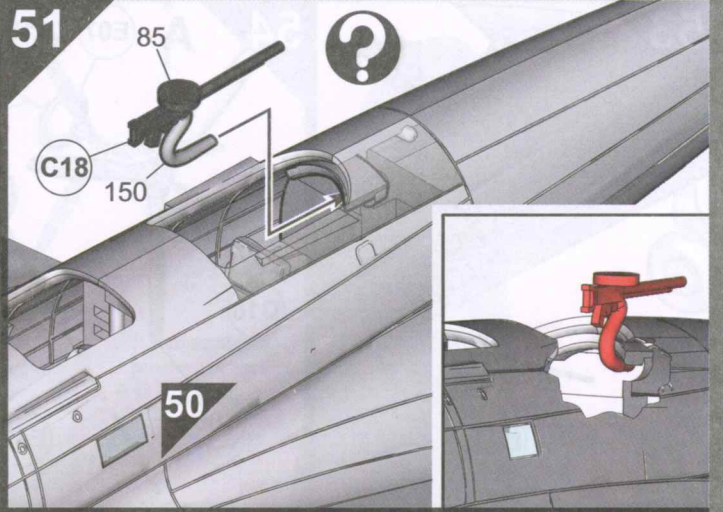
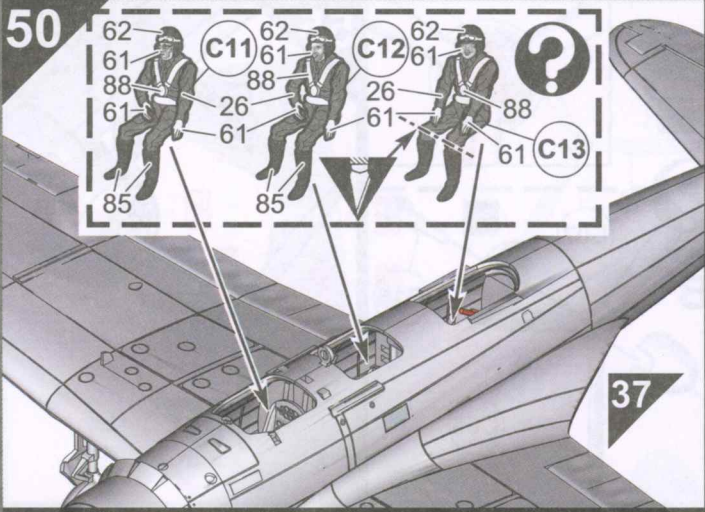

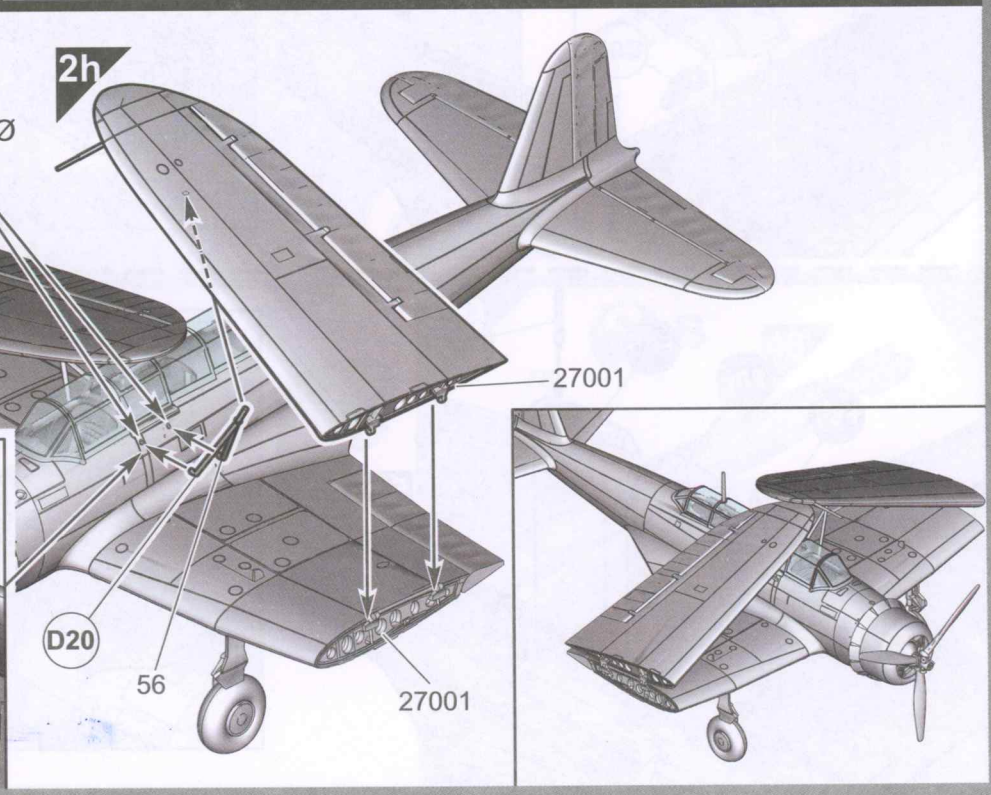
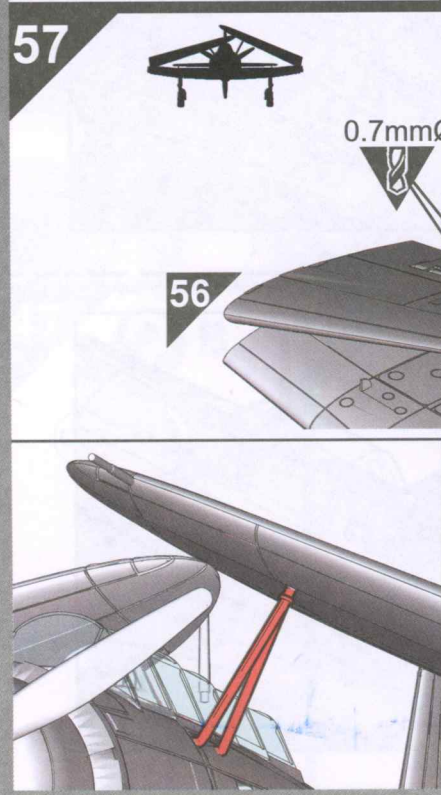
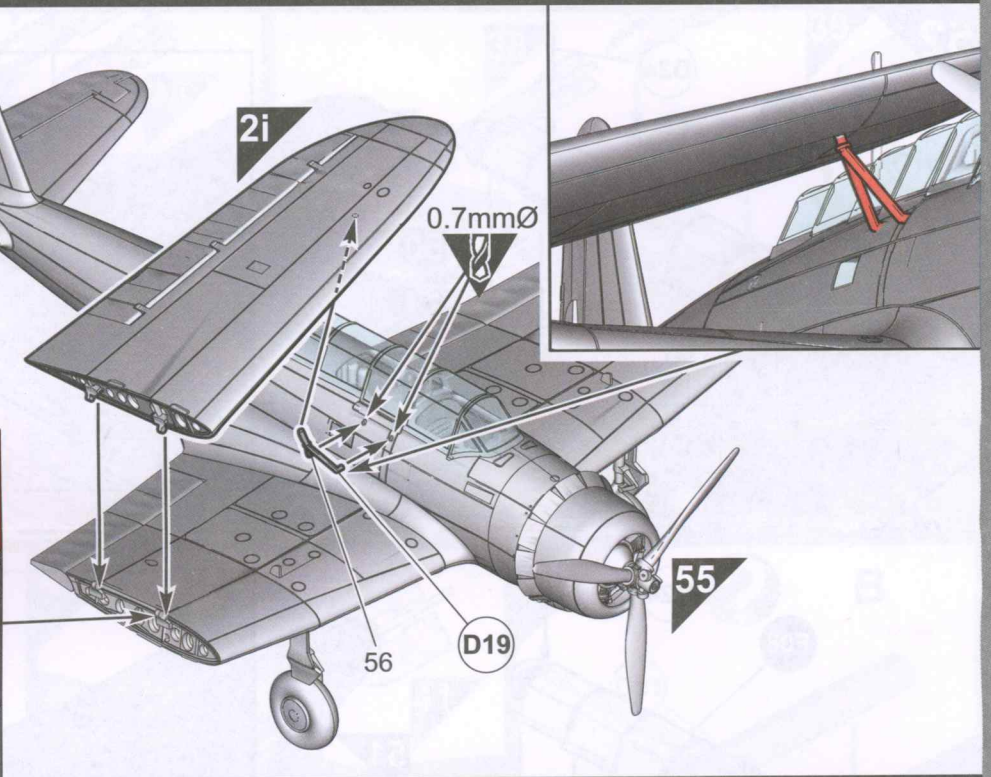
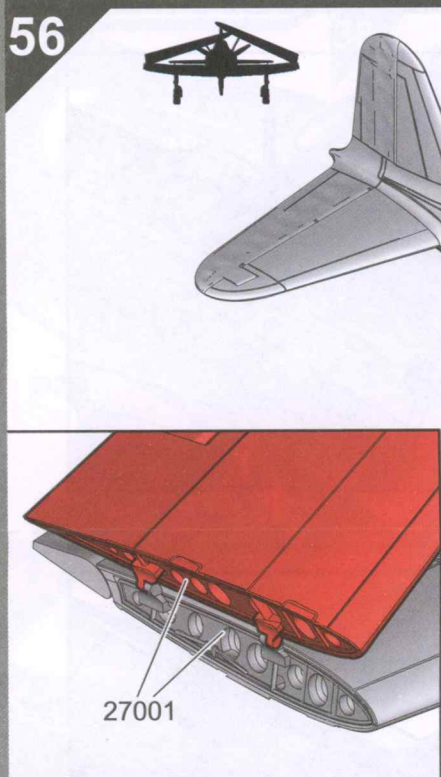
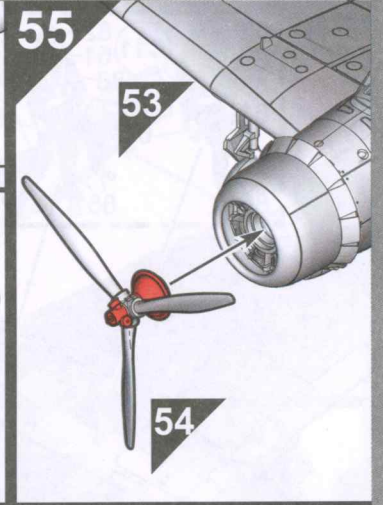
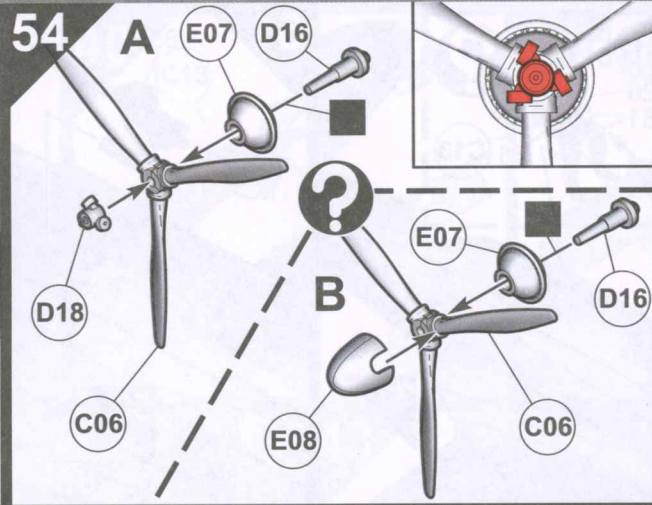
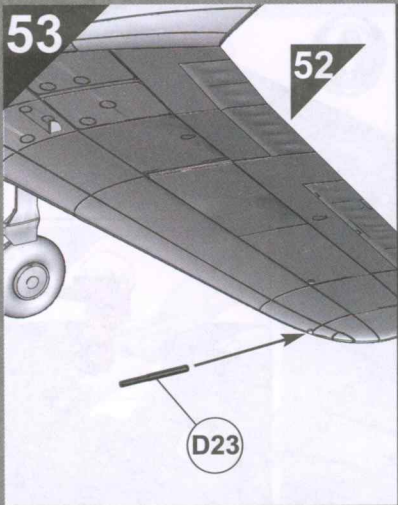

**A Nakajima B5N2 "Kate"**  
Imperial Japanese Navy carrier Shokaku, Pearl Harbor, December 7th 1941.

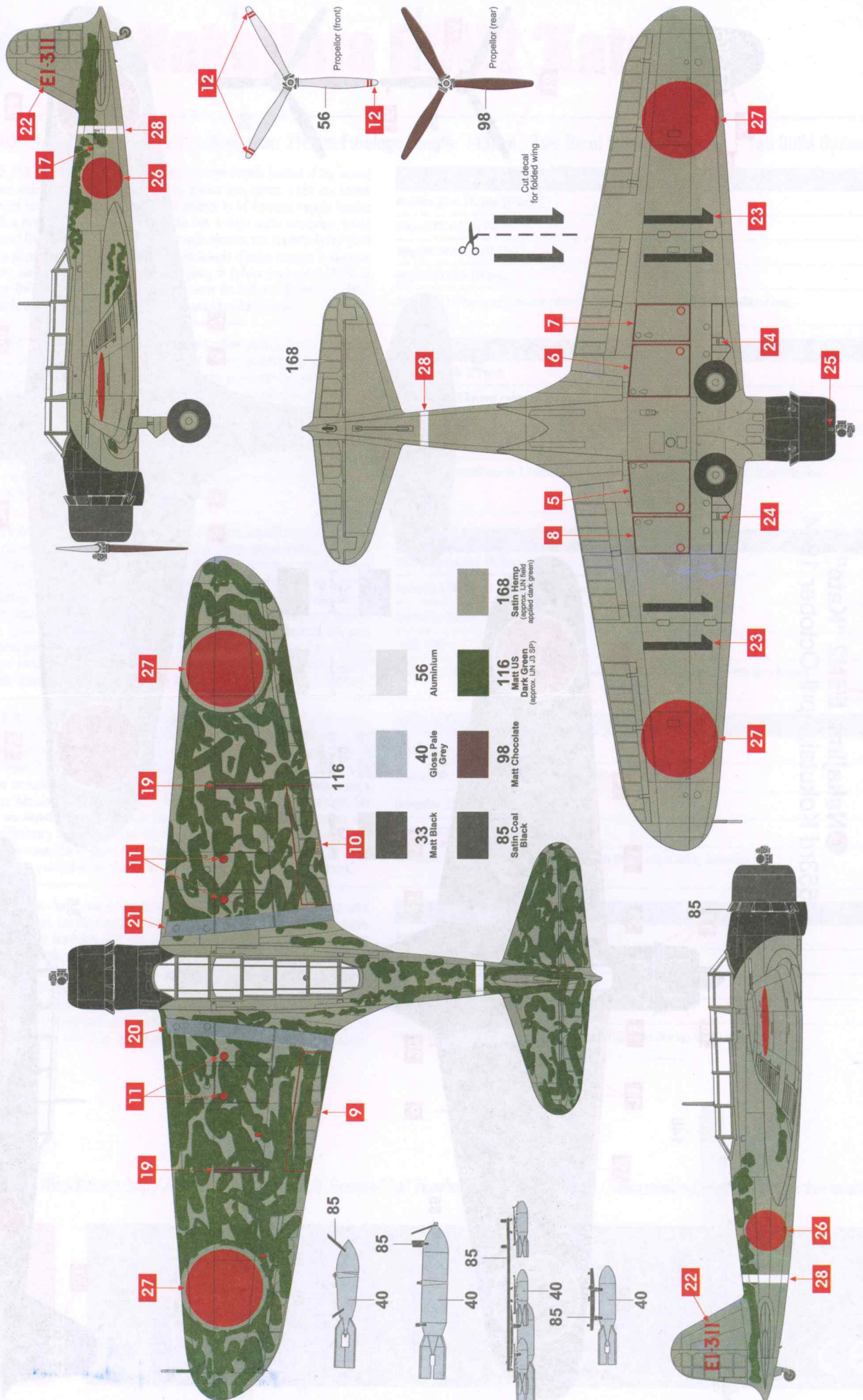

**B Nakajima B5N2 "Kate"**  
553rd Kokutai, April-October 1944.

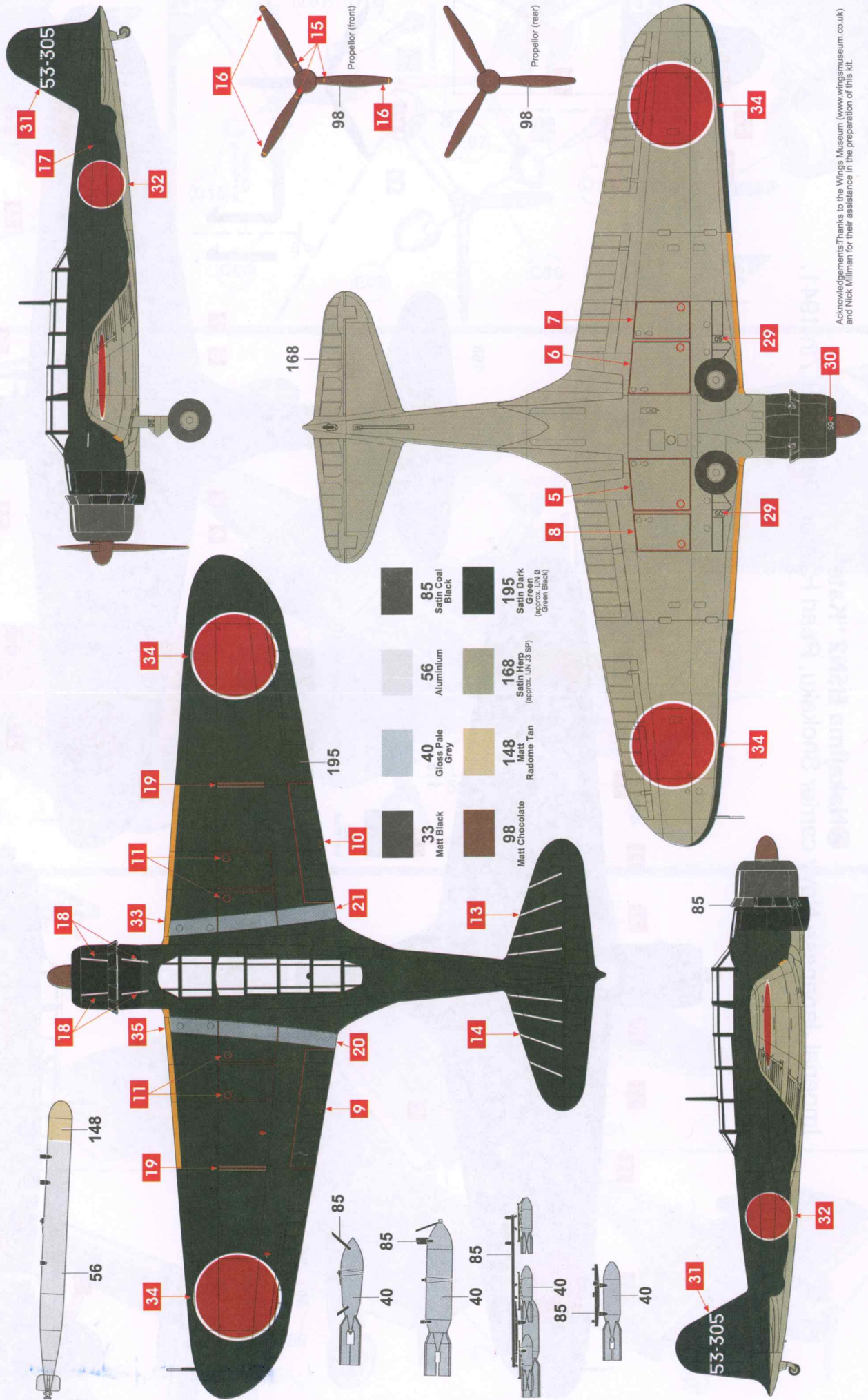

Acknowledgements: Thanks to the Wings Museum ([www.wingsmuseum.co.uk](http://www.wingsmuseum.co.uk)) and Nick Millman for their assistance in the preparation of this kit.

© Nakajima B5N2 'Kate'  
Surrender markings, 1945

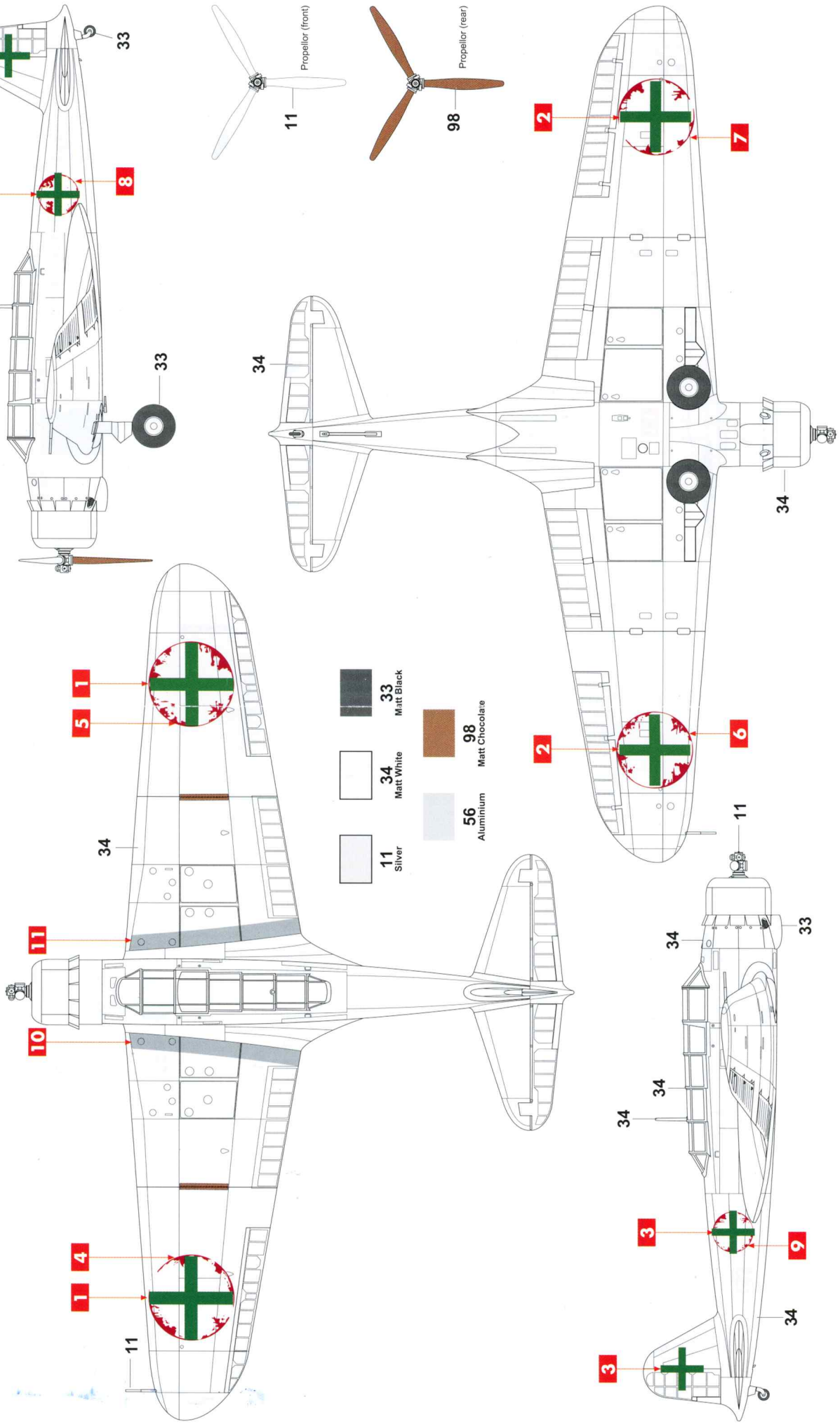

# D Nakajima B5N2 'Kate' Technical Air Intelligence Centre, 1945

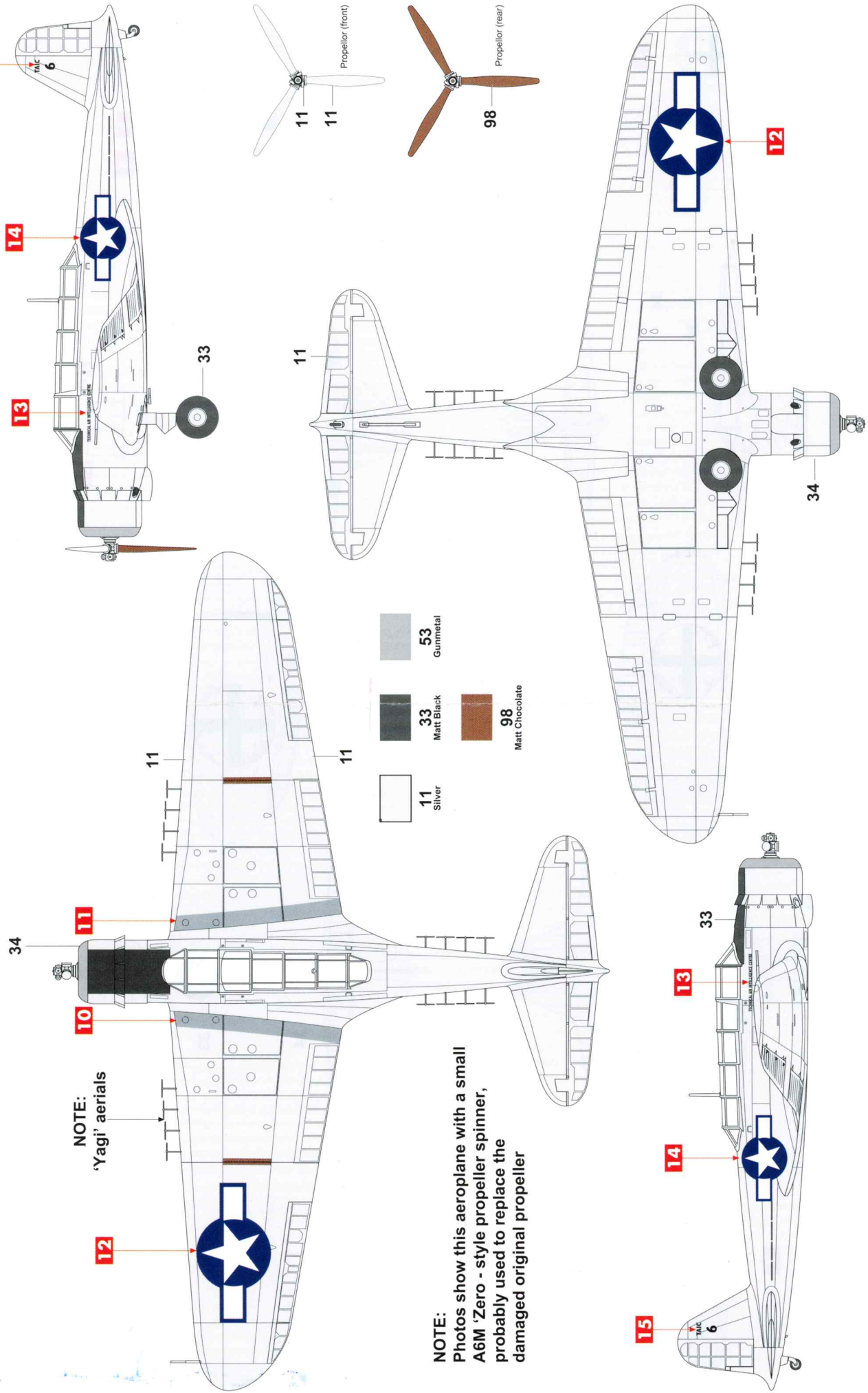

NOTE:  
'Yagi' aerials

NOTE:  
Photos show this aeroplane with a small  
A6M 'Zero' - style propeller spinner,  
probably used to replace the  
damaged original propeller