

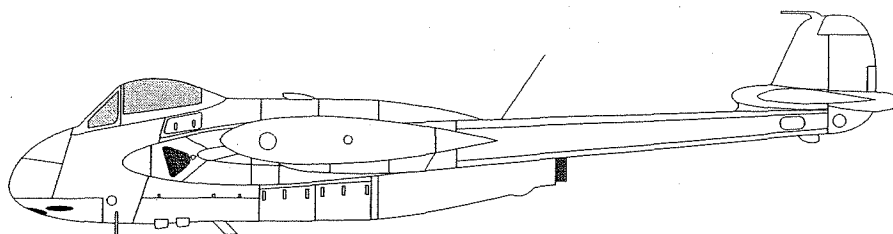

Classic Airframes



Venom FB.4

In a quest to improve the performance of the Vampire, the DH112 was designed to incorporate the more powerful Ghost jet engine. Although similar in appearance, extensive airframe changes were incorporated. A thinner wing with a straight trailing edge and slight leading edge sweep and a longer-span strengthened tailplane were the most obvious design changes. The first two prototypes were intended to be designated Vampire FB.8s, but it was felt that the design changes were substantial enough to warrant a new type number as well as a new name. The first Venom FB.1 took to the air in September, 1949. In addition to concern over the lack of an ejection seat, early trials showed a poor roll rate as well as unpredictable stall characteristics, but acceptable enough performance to warrant production. 373 FB.1s were supplied to the RAF, with Germany-based 11 Squadron being the first to be equipped in August 1952. Operations soon proved that at higher altitudes the Venom wasn't fast enough to be an effective interceptor. However, at lower altitudes it was not only quite maneuverable, but also proved to be a very stable platform when used for the ground attack role. Performance shortcomings Venom FB.1 were addressed with the much improved FB.4, which featured powered ailerons and redesigned rudders. The Venom was also developed into two-seat night-fighter versions as well as the carrier-based Sea Venom.

Venom FB.4 Specifications

Powerplant:	Ghost jet engine (4850 lb. thrust)	Armament:	4x 20mm cannon 8x 60lb. rockets 2x bomb pylons (various loads)
Wing Span:	41' 8"		
Length:	31' 10"		
Maximum Speed:	600 mph		

This model kit is intended for *experienced* modelers. The nature of low-pressure molded kits such as this require additional time and effort to clean up and fit the parts, as well as experience with the various media utilized to provide the most accurate effect on the finished model. Use CyA ('super') glue to assemble Resin parts.

Classic Airframes, Inc.
P.O. Box 577580 Chicago, IL 60657-7580 USA

Assembly Instruction Symbols



MULTIPLE ASSEMBLIES



BEND



OPTIONAL



DRILL



CUT



SYMMETRICAL ASSEMBLIES

Paint Reference Guide



Black-grey



Burnt Metal



Aluminum



Black



Silver



Gunmetal

Parts

PLASTIC PARTS

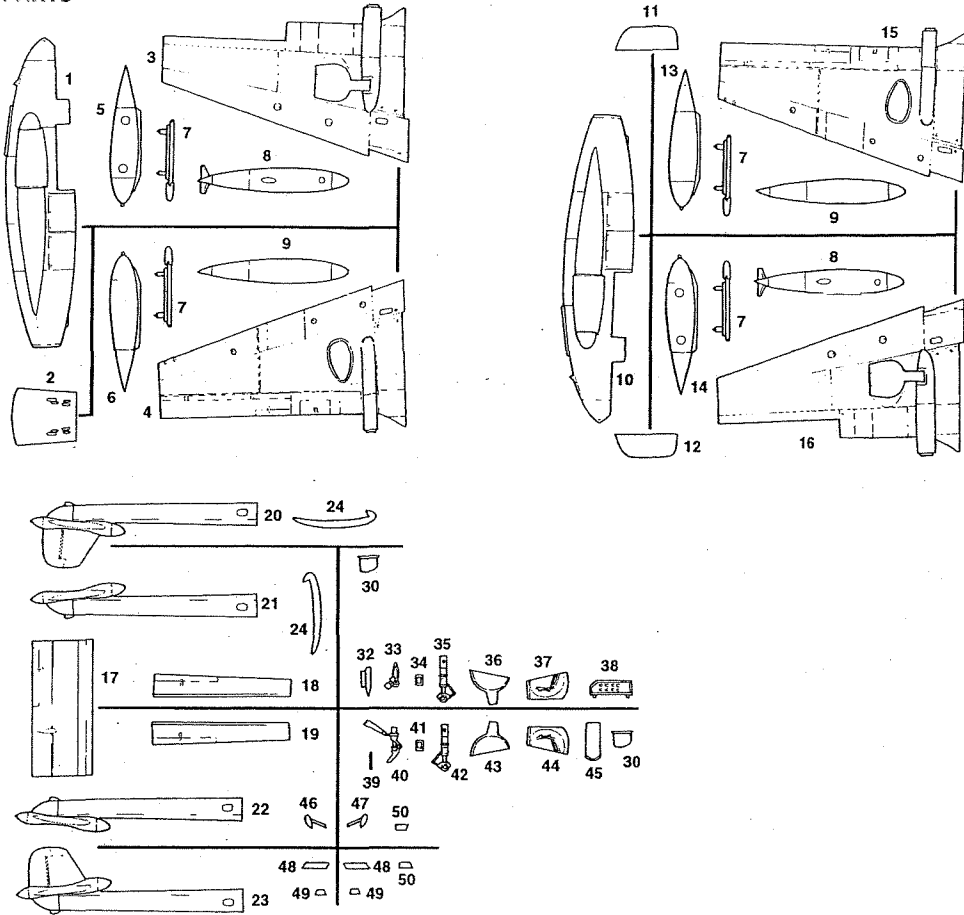

RESIN PARTS

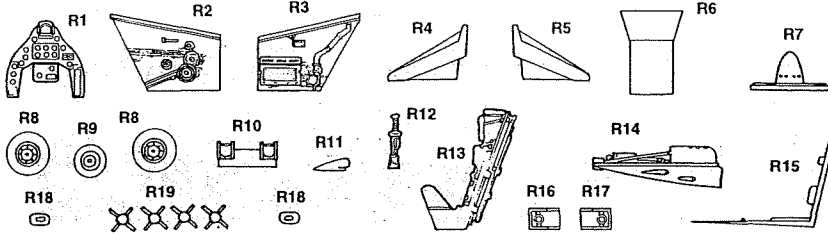

CLEAR PARTS

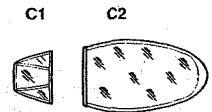

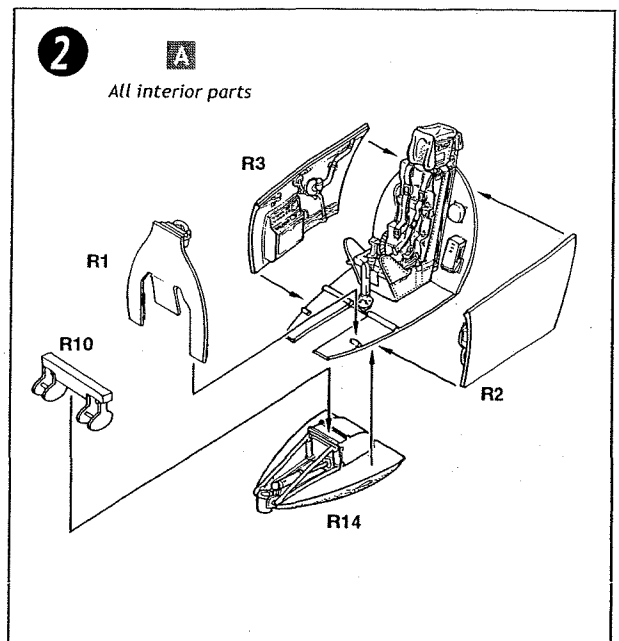
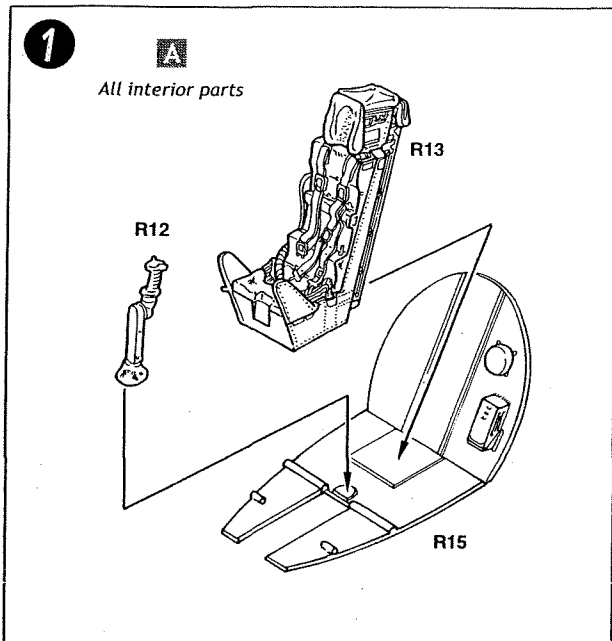

NOTE - Be sure to dry-fit and check alignment of all parts during assembly

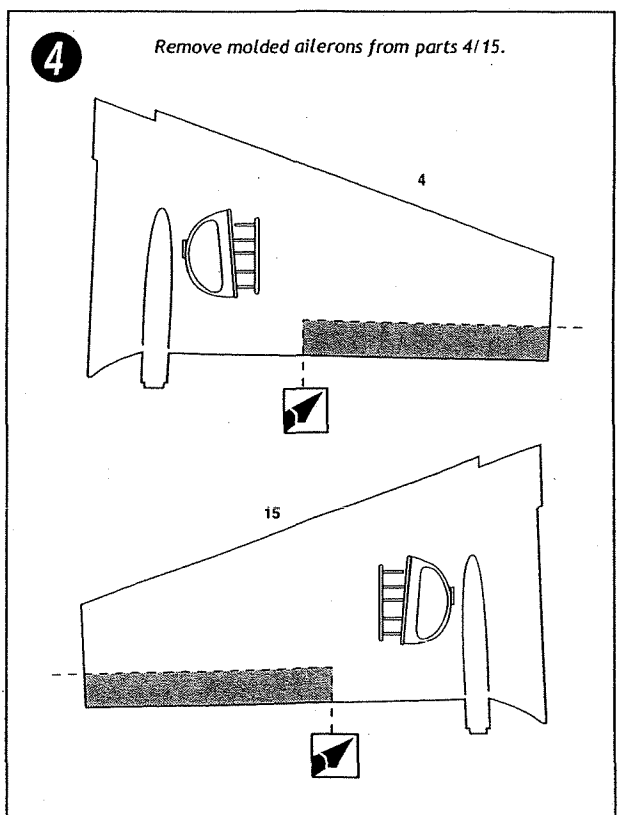
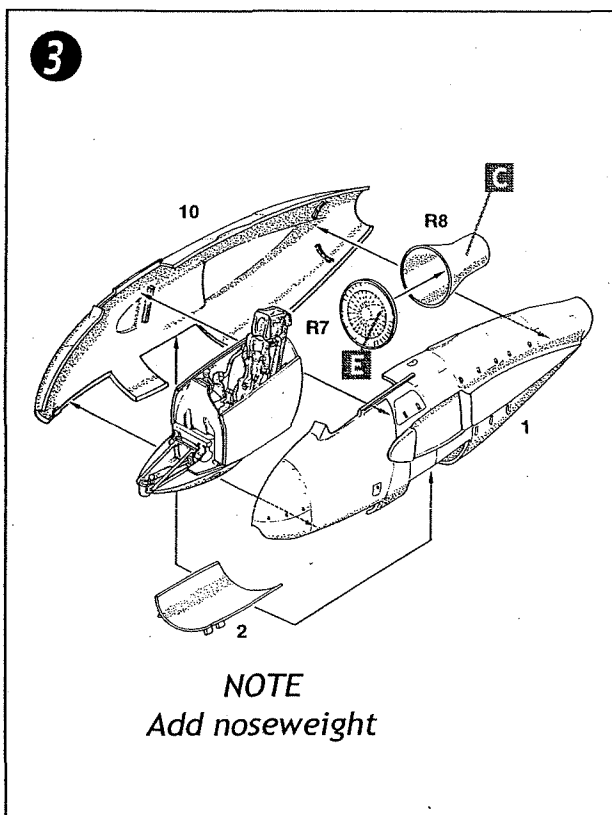

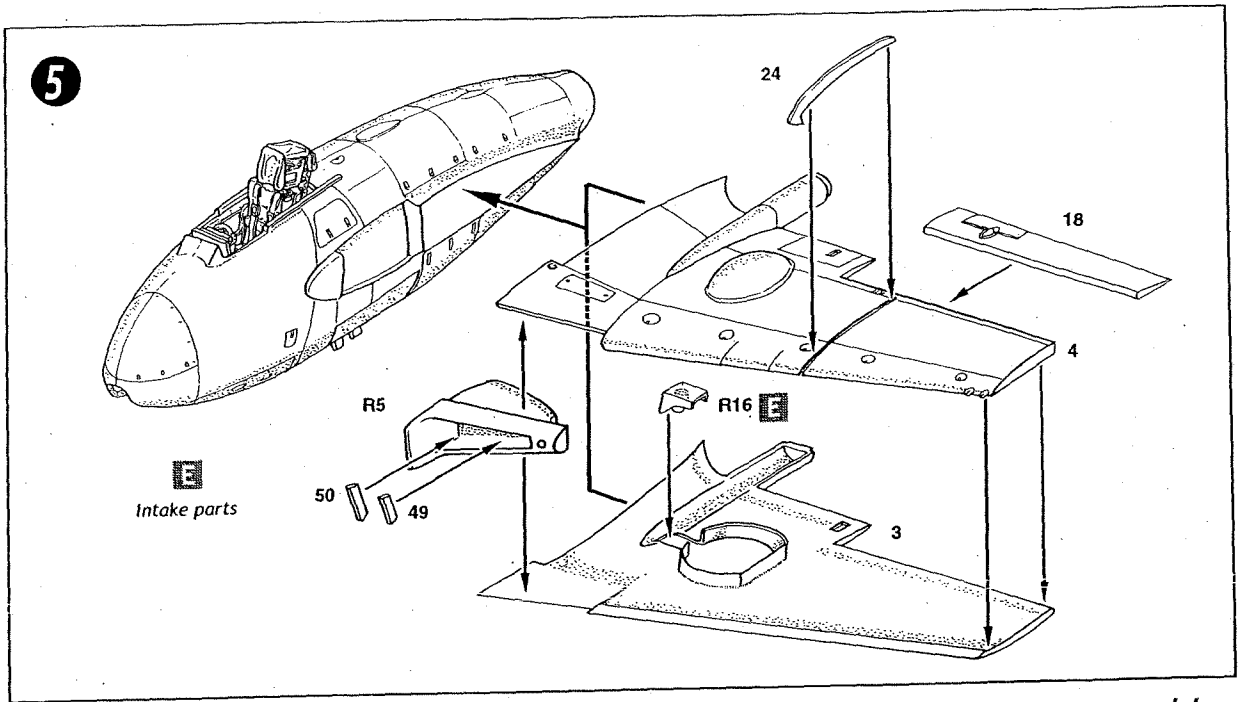

NOTE - Be sure to dry-fit and check alignment of all parts during assembly

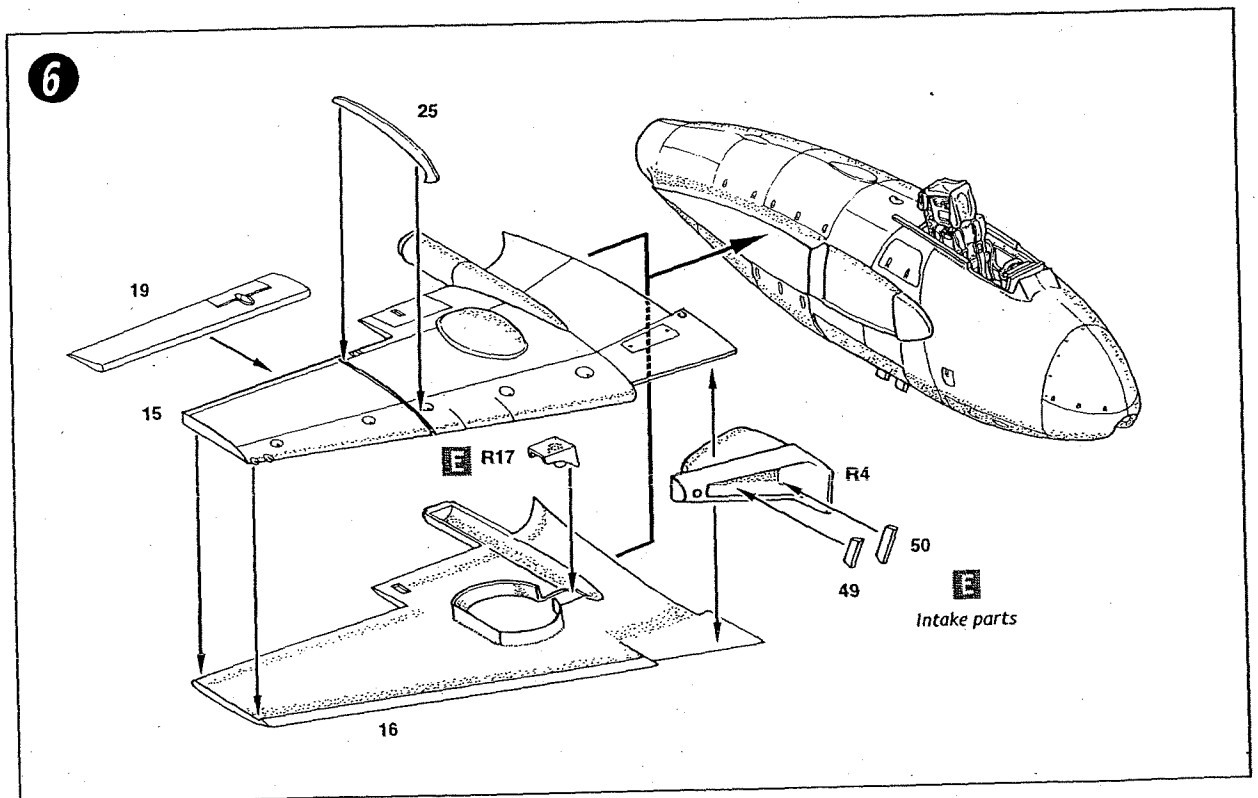

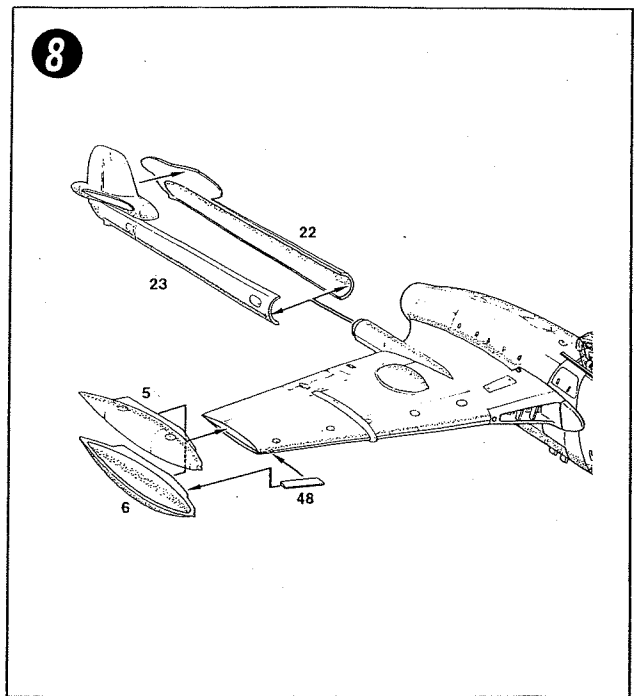
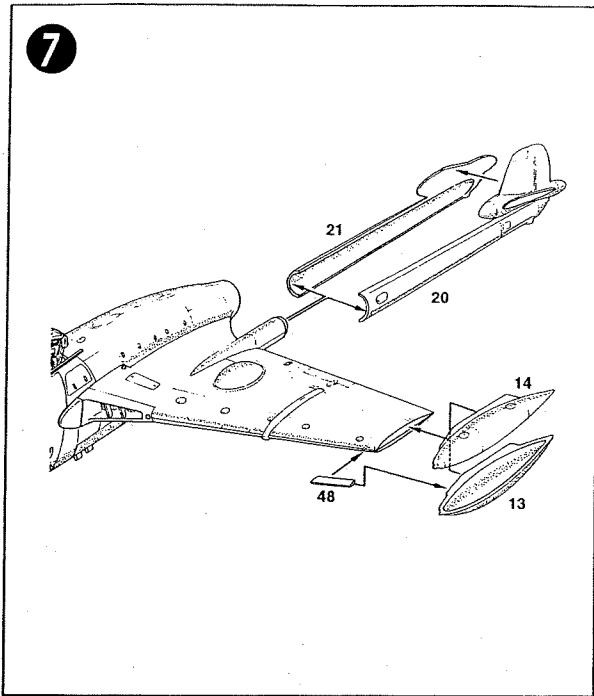

NOTE - Be sure to dry-fit and check alignment of all parts during assembly

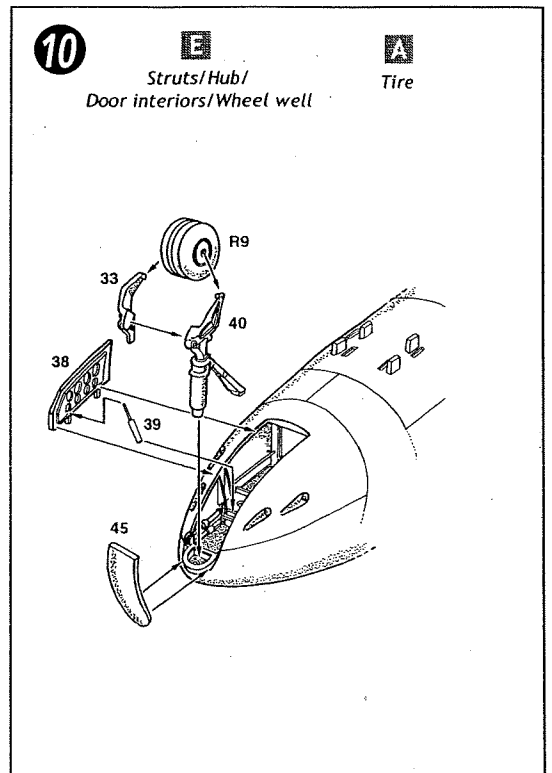
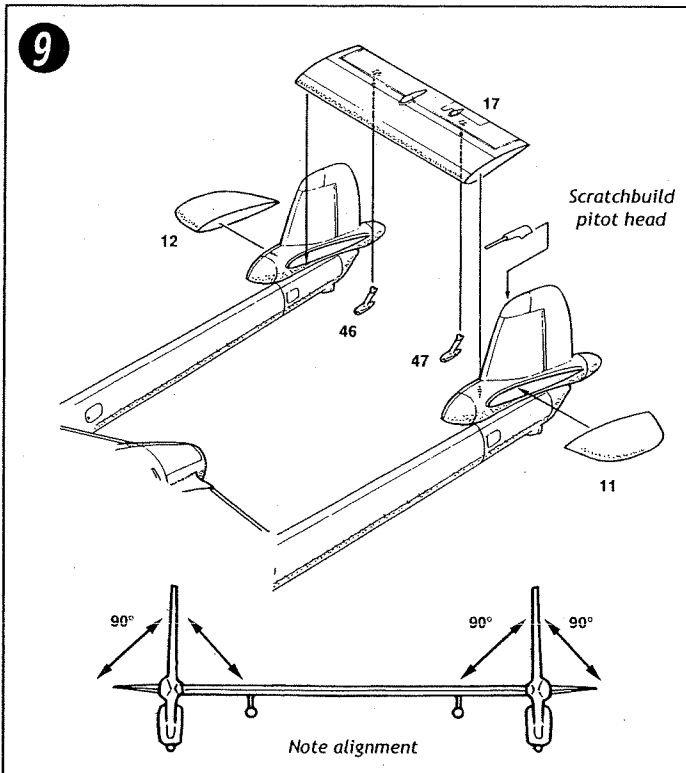

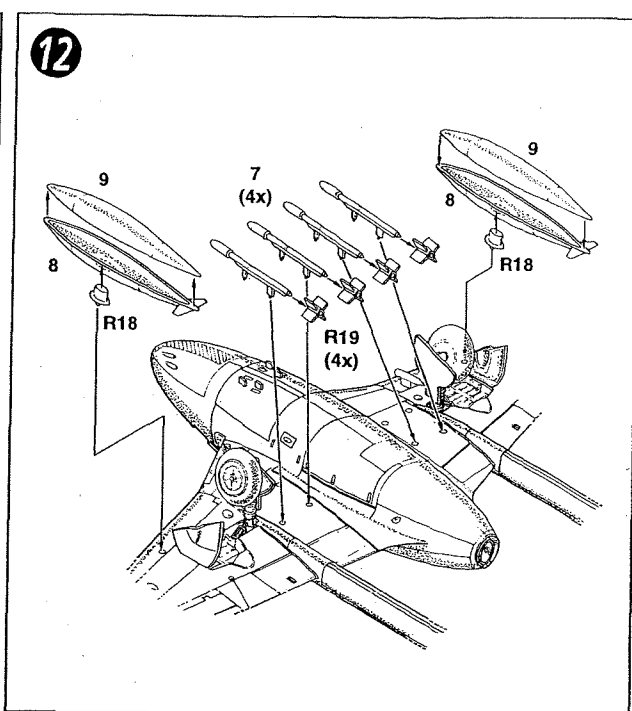
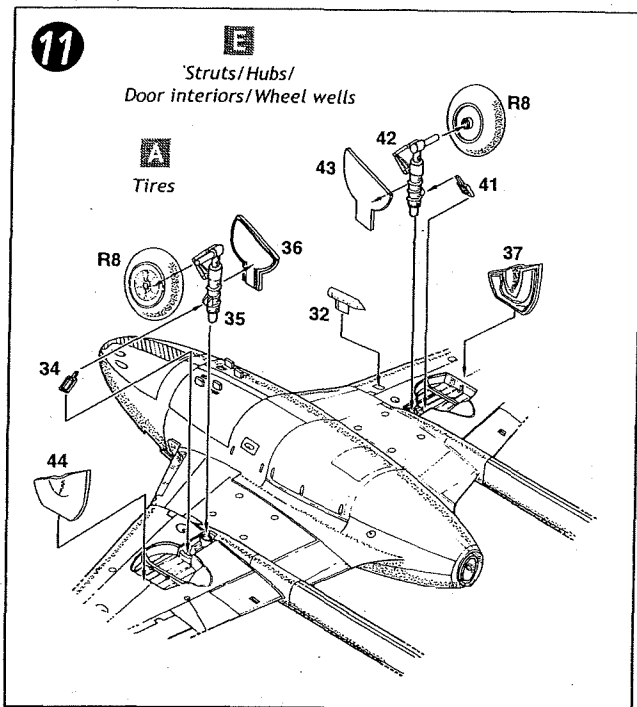

NOTE - Be sure to dry-fit and check alignment of all parts during assembly

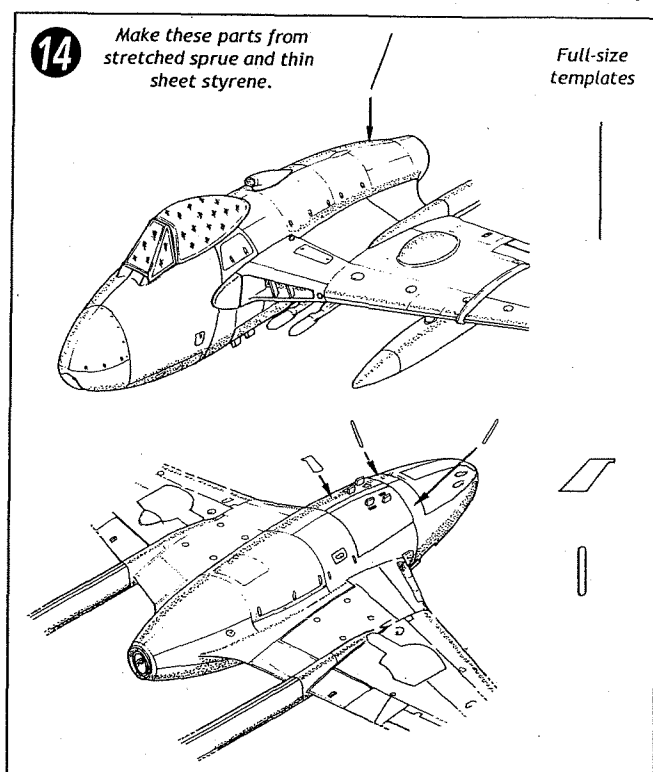
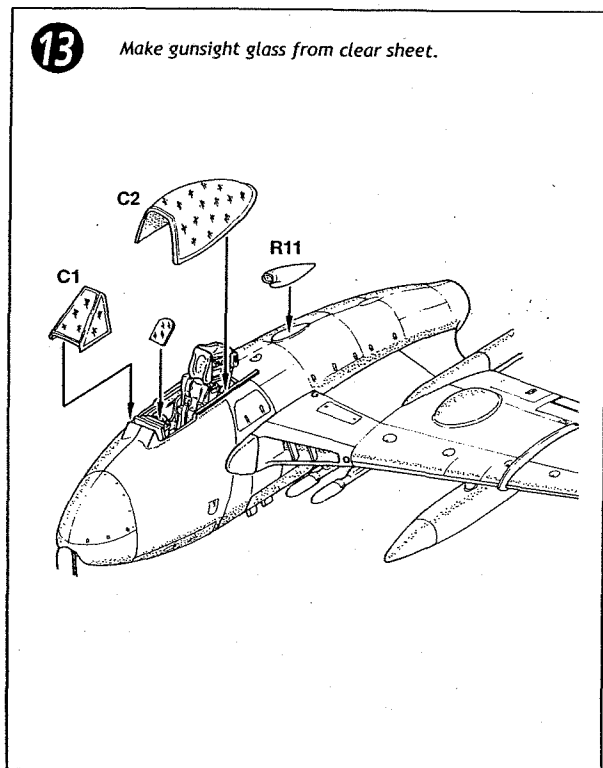

Venom FB.4 STENCIL GUIDE

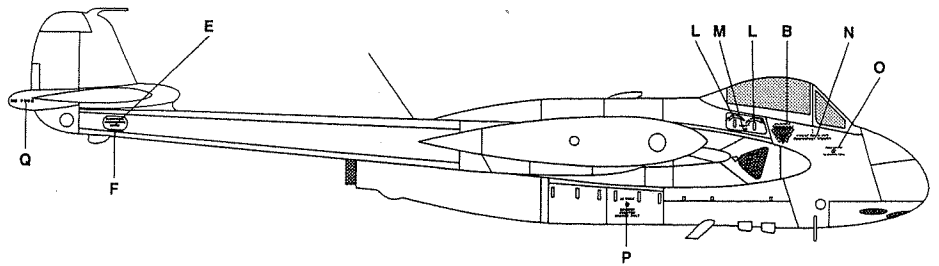
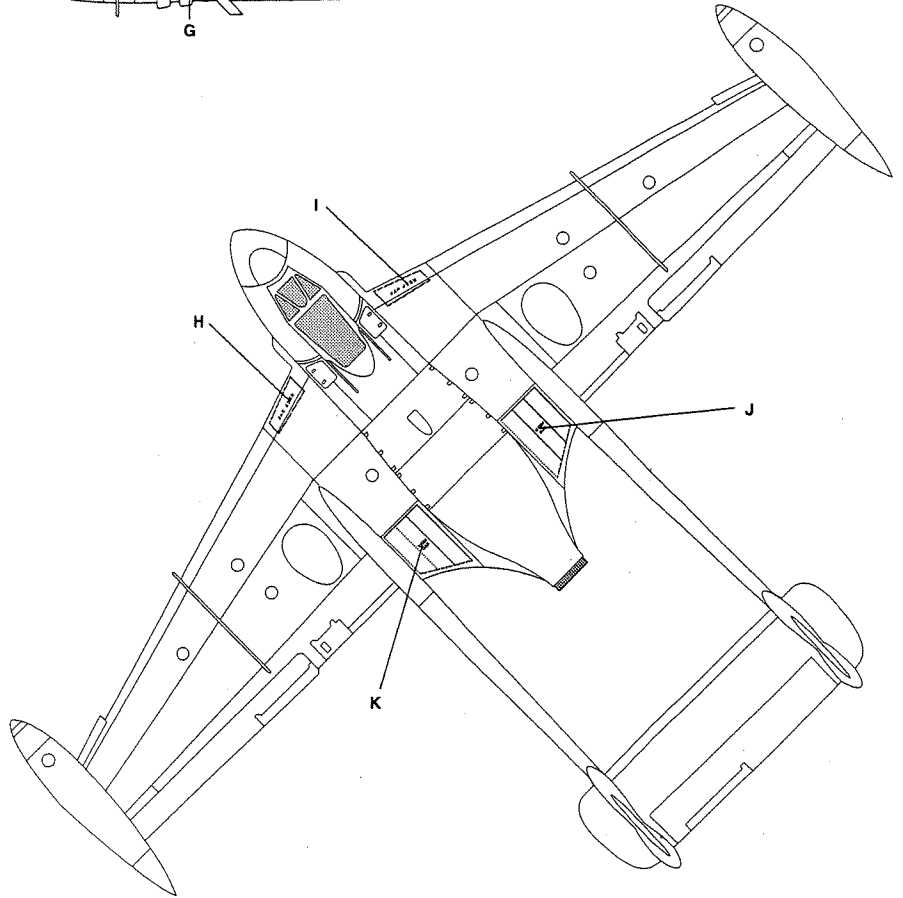
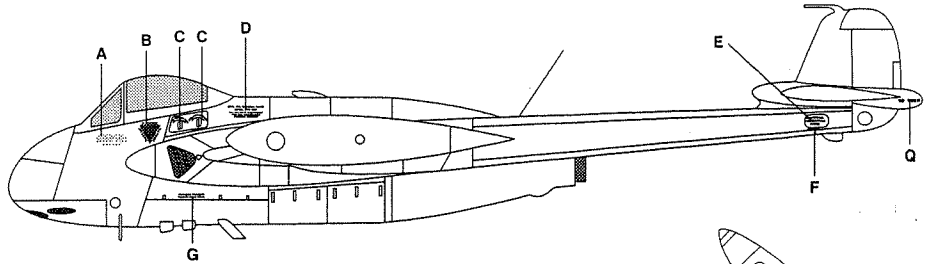

Classic Airframes #4110 • Venom FB.4 Color & Marking Guide

249 Squadron, RAF Akrotiri, 'Operation Musketeer', circa November 1956

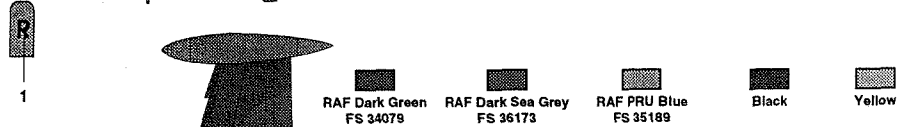
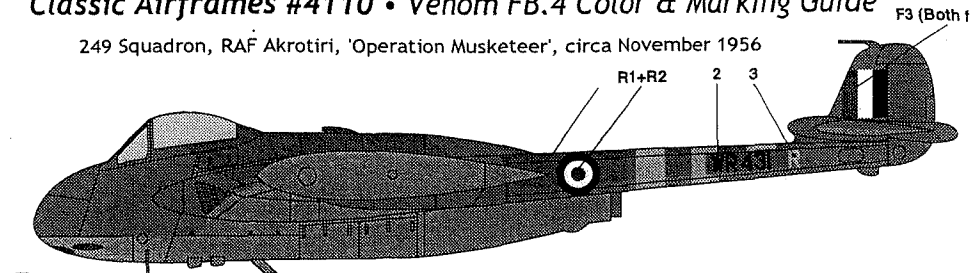

View this Color & Marking Guide in color at www.classicairframes.com

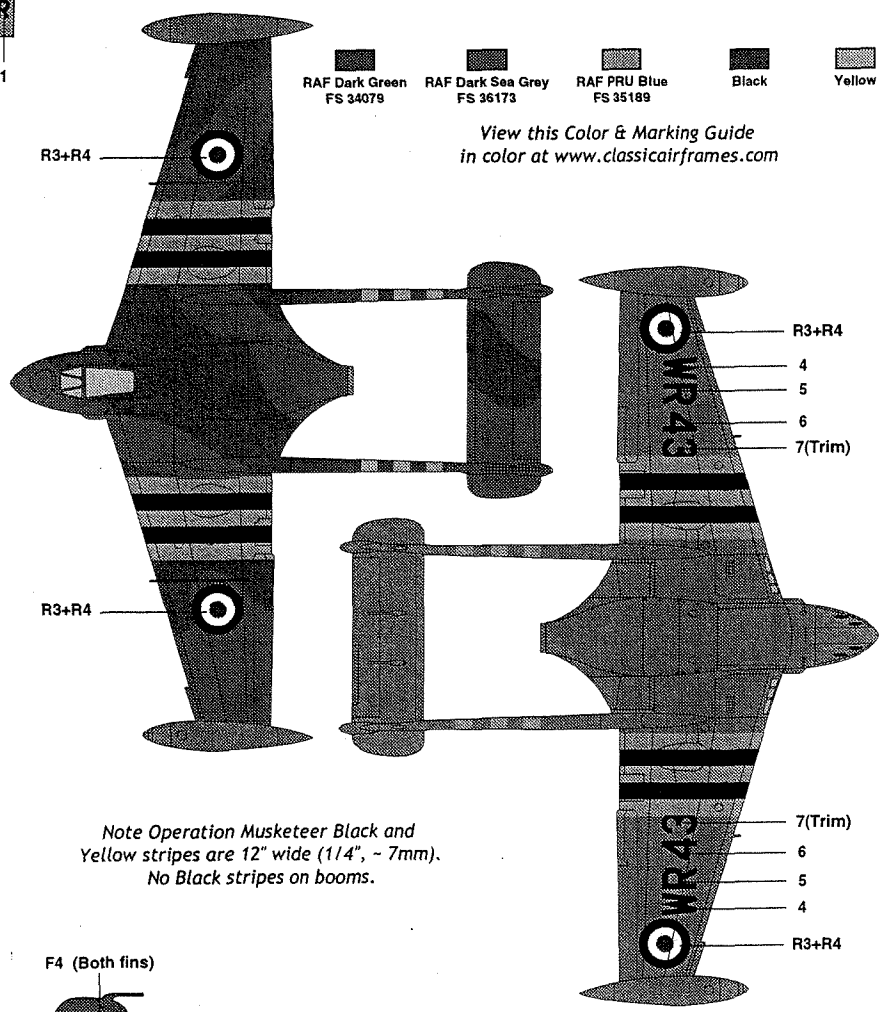

Note Operation Musketeer Black and Yellow stripes are 12" wide (1/4", ~ 7mm). No Black stripes on booms.

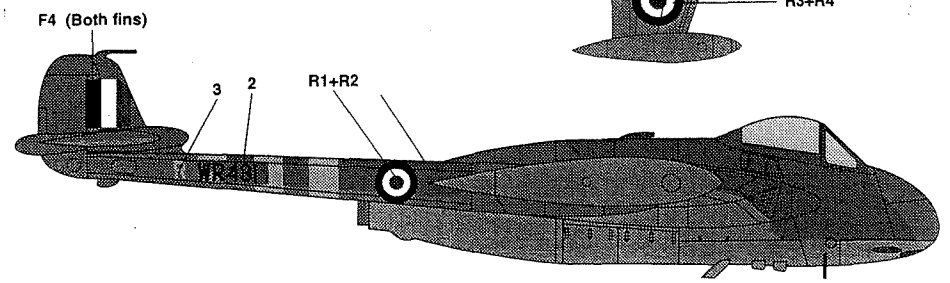

ins) 28 Squadron, RAF Kai Tak, circa June 1952

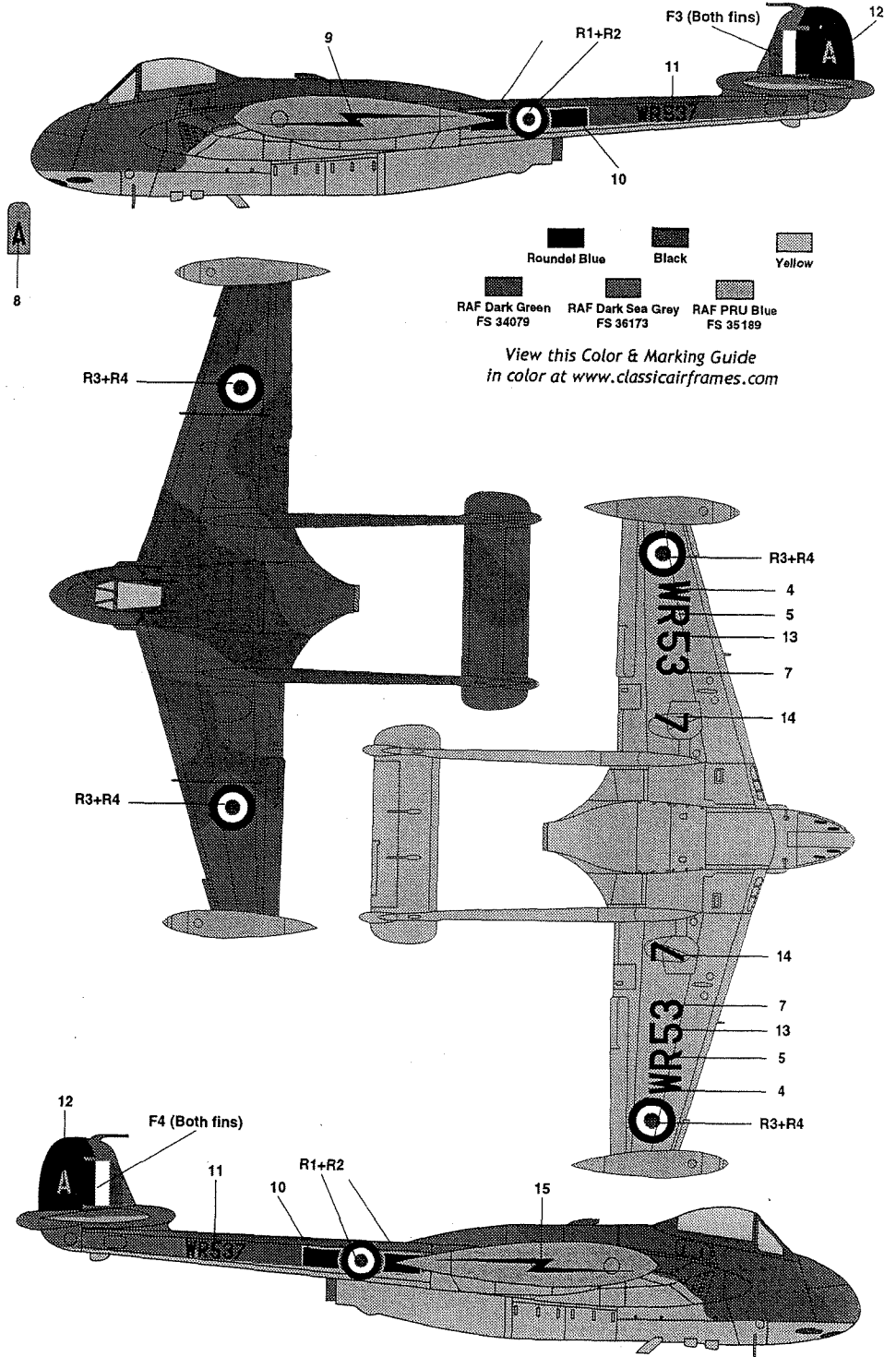

Classic Airframes #4110 • Venom FB.4 Color & Marking Guide

11 Squadron, RAF Wunsdorf, circa 1955-57.

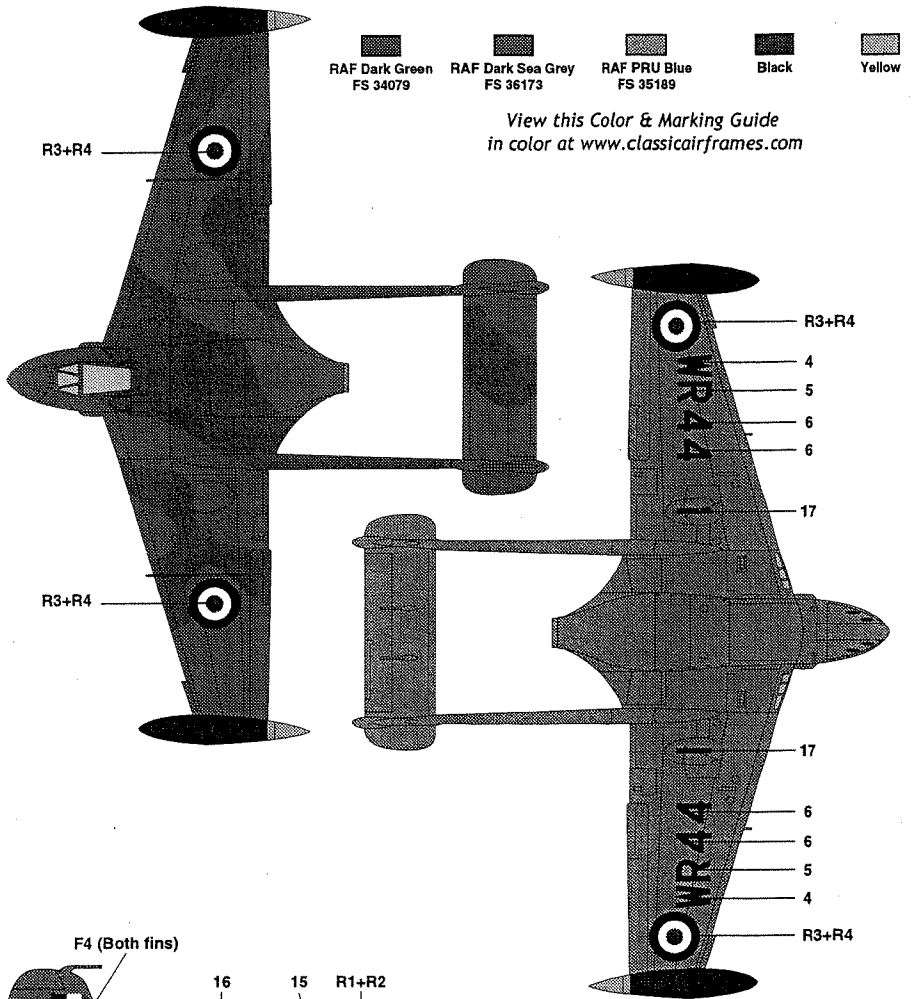
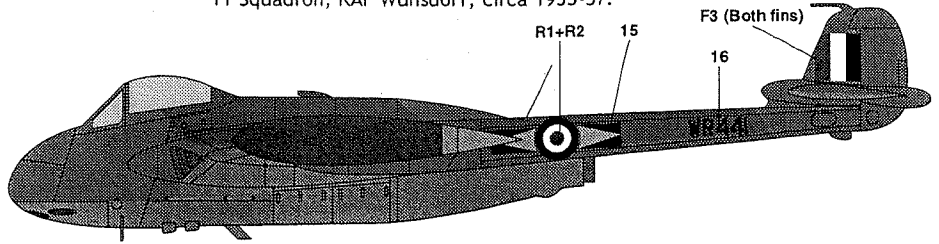

- RAF Dark Green
FS 34079
- RAF Dark Sea Grey
FS 36173
- RAF PRU Blue
FS 35189
- Black
- Yellow

View this Color & Marking Guide
in color at www.classicairframes.com

