

MARMON-HERRINGTON Mk II

MFF type



Cat. no. 35023

Scale 1/35



1 Element złożony we wcześniejszym etapie
Element assembled in previous step

1 Element po złożeniu w aktualnym etapie
Element after assembly in actual step

? Wersja do wyboru
Version to choose

1 Kalkomania
Decal

A Kolor farby
Paint colour

■ Część nie do użycia
Part not for use

45° Zegnij część fototrawioną
Bend photoetched part

↙ Po gięciu
After bending

		Vallejo Model Air	Vallejo Model Color
black	A	71057	70950
rust	B	71080	70846
gunmetal	C	71072	70863
olive green	D	71007	70967
light stone	E	71028	70916
wood	F	71077	70913

Przed montażem przeczytać instrukcję. Przestrzegać kolejności montażu podanego w instrukcji! Klej i farby nie wchodzi w skład zestawu.

Please read instruction before assembly. Obey sequence of assembly like in instruction. Glue and paints not included.

Ramka przezroczysta D
Frame clear D

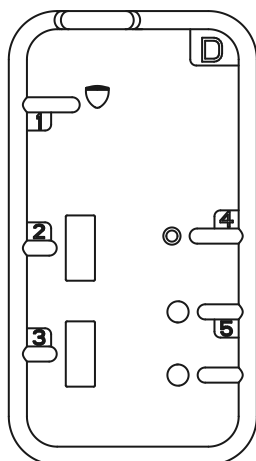

Wieżyczka
Turret

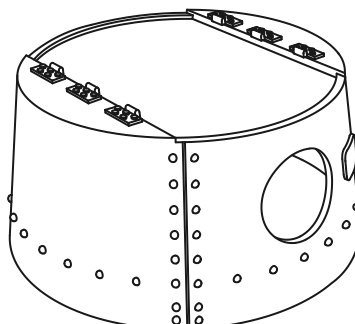

Opona 5 szt
Tire 5 pcs

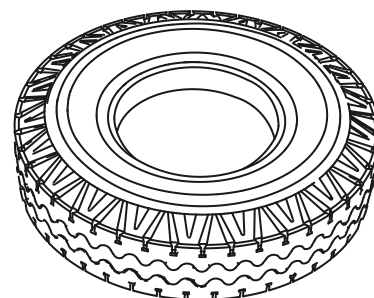

International Business Group
ul. Benedykta Hertza 2
04-603 Warszawa
Poland

tel +48 22 8159150
fax +48 22 8159151
ibgsc@ibg.com.pl
www.ibg.com.pl

Ramka A / Frame A

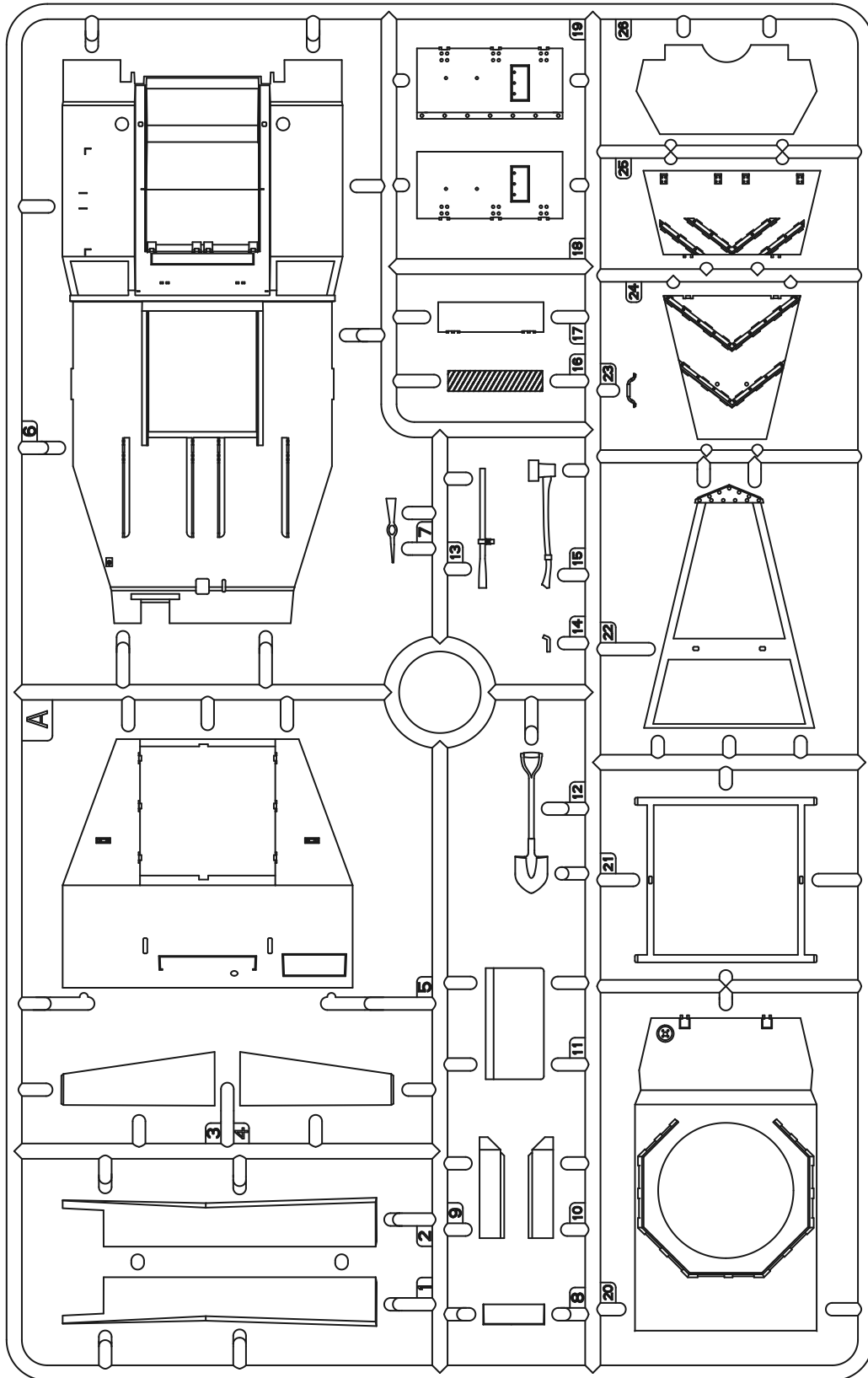

Ramka B / Frame B

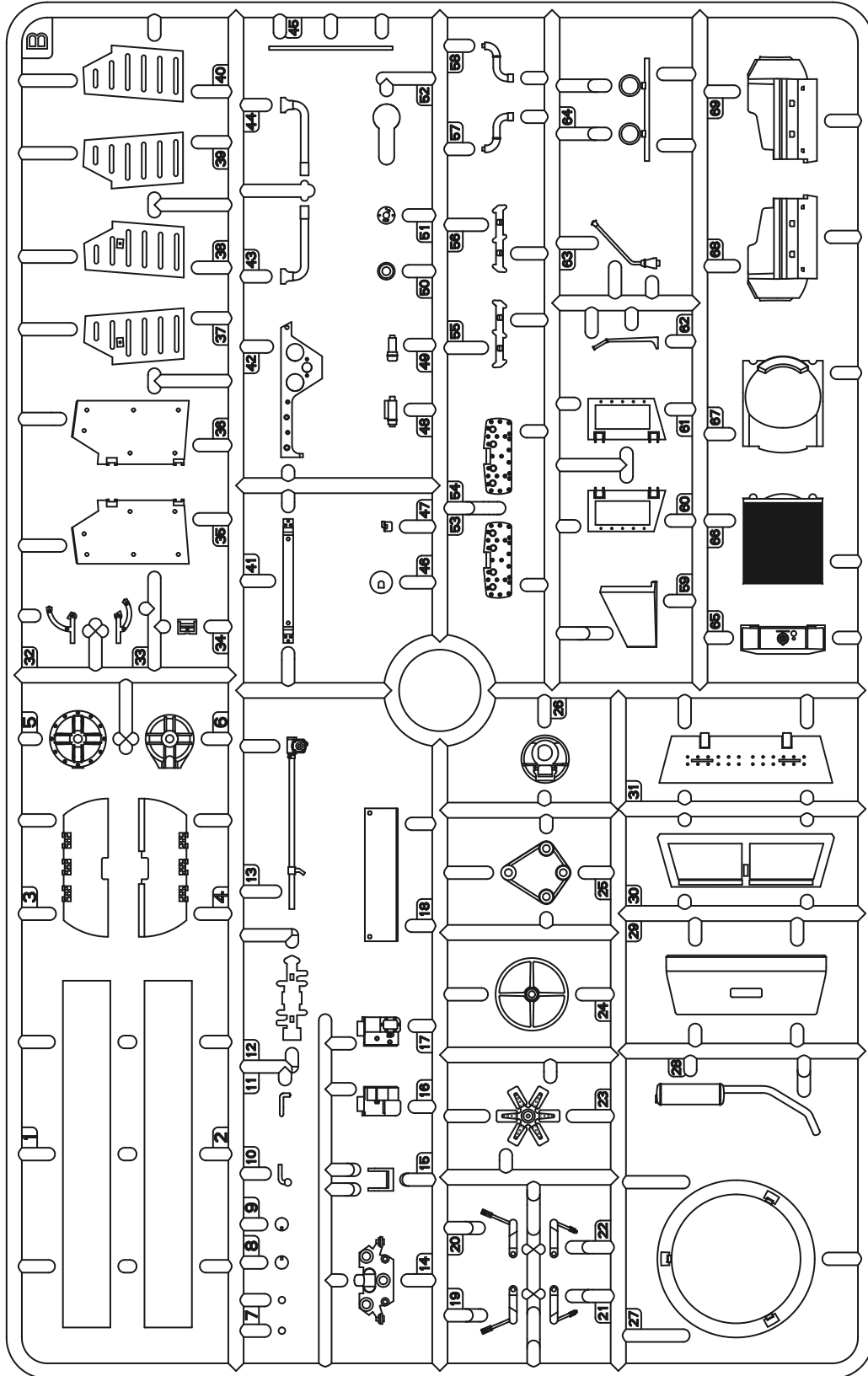

International Business Group
ul. Benedykta Hertza 2
04-603 Warszawa
Poland

tel +48 22 8159150
fax +48 22 8159151
ibgsc@ibg.com.pl
www.ibg.com.pl

Ramka F / Frame F

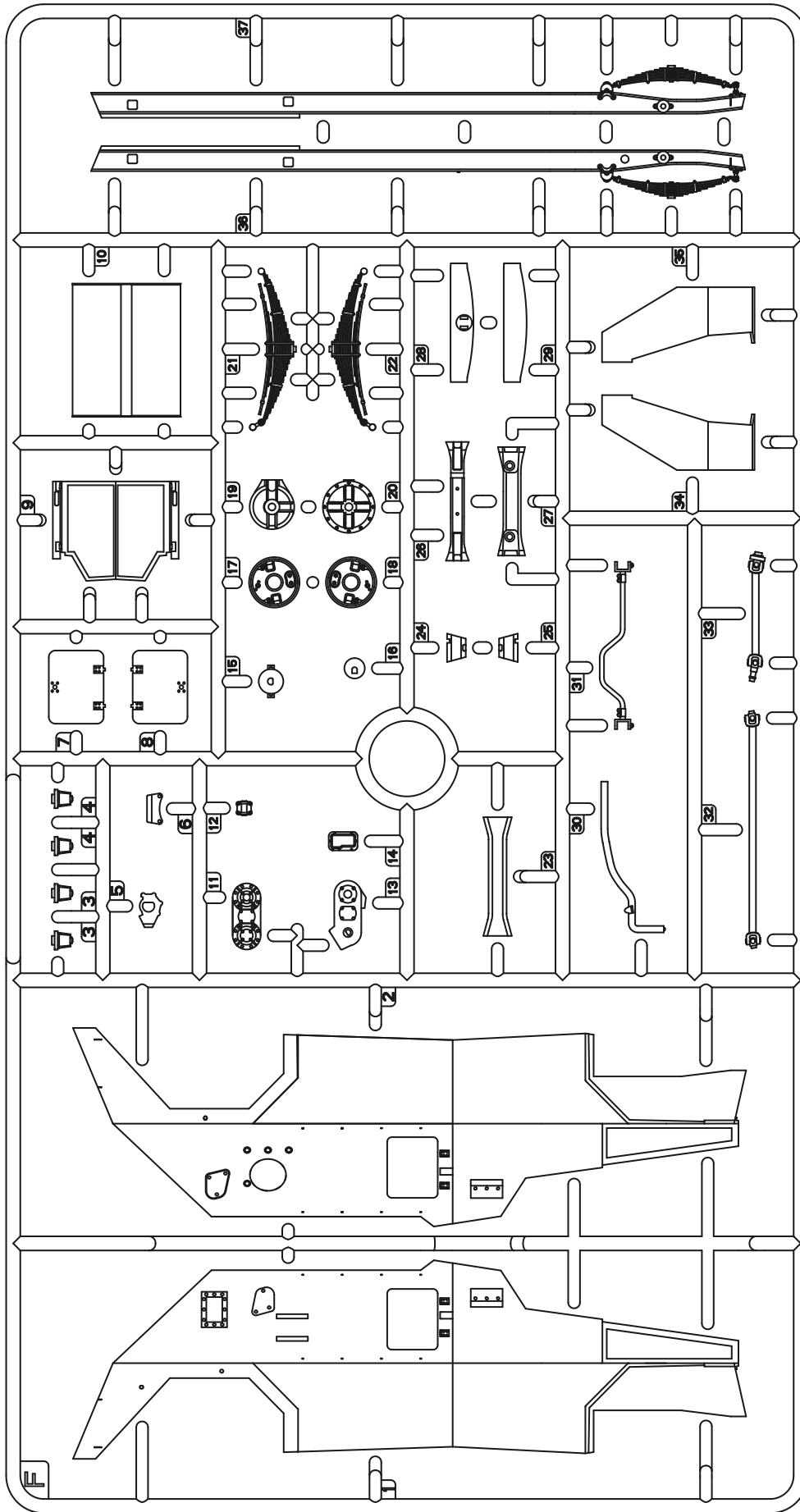

International Business Group
ul. Benedykta Hertza 2
04-603 Warszawa
Poland

tel +48 22 8159150
fax +48 22 8159151
ibgsc@ibg.com.pl
www.ibg.com.pl

Ramka C - 2 szt / Frame C - 2 pcs

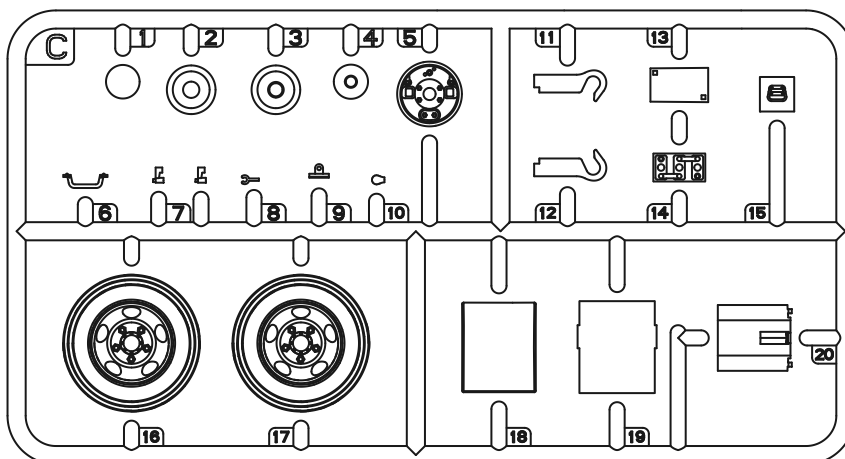

Ramka Ca / Frame Ca

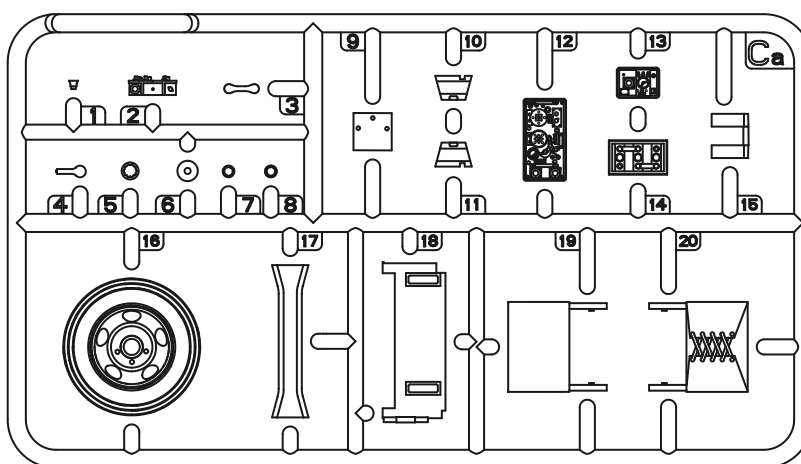

Ramka Ce / Frame Ce

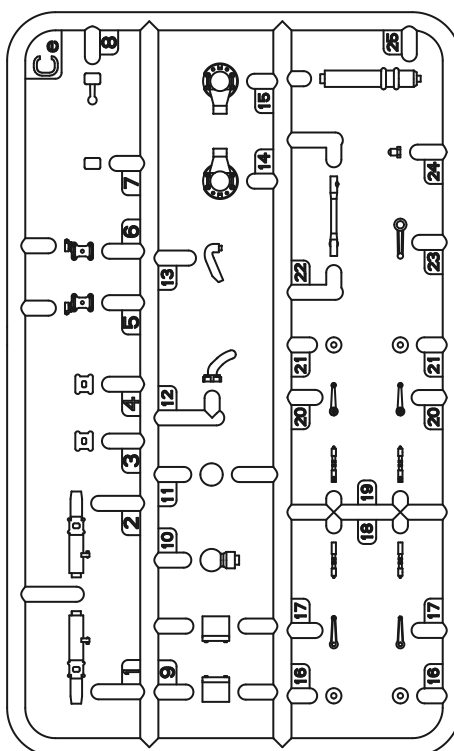

Ramka Cb - 2 szt / Frame Cb - 2 pcs

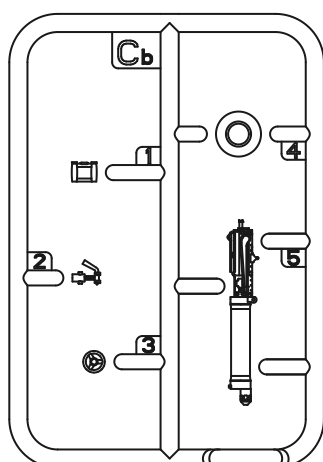

Części fototrawione (PE) / Photoetched parts (PE)

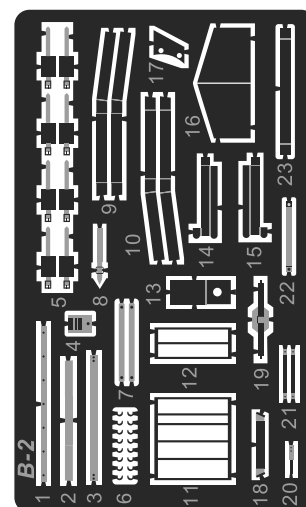

**ETAP 1
STEP 1**

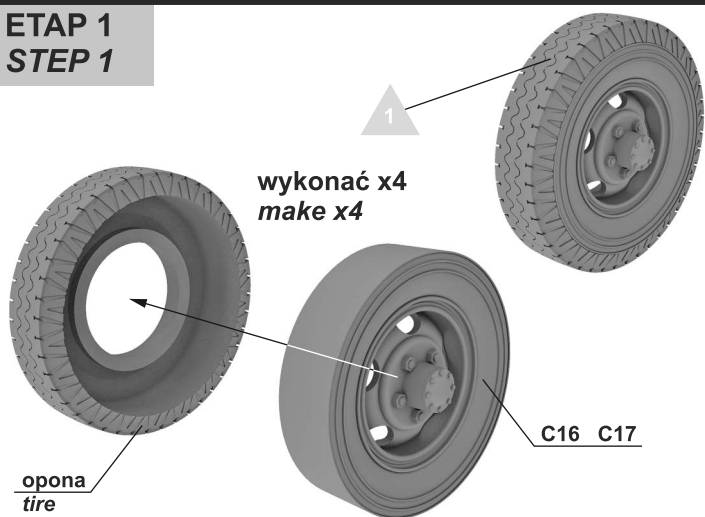

**ETAP 2
STEP 2**

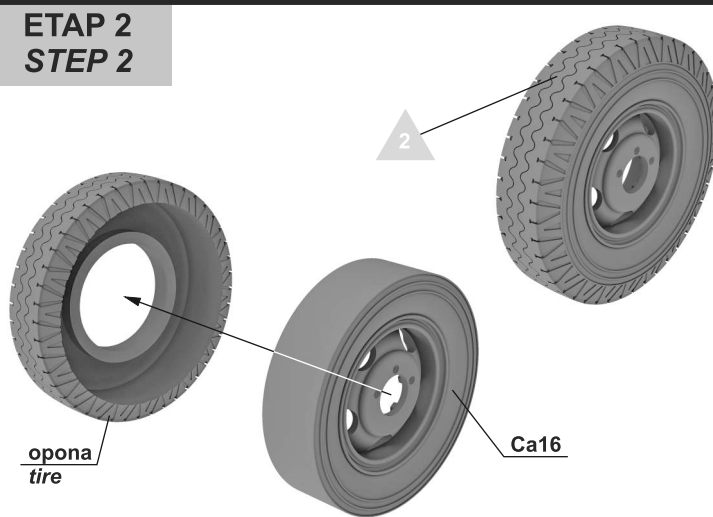

**ETAP 3
STEP 3**

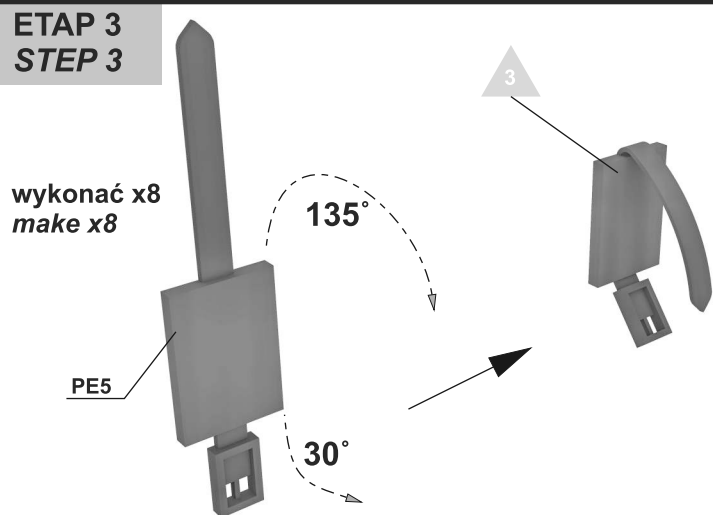

**ETAP 4
STEP 4**

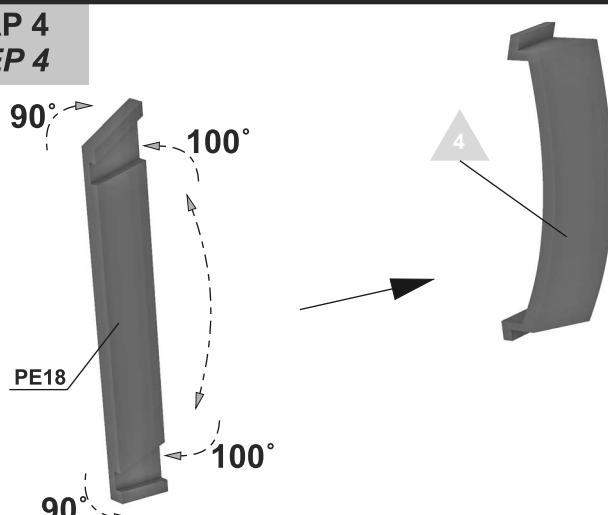

**ETAP 5
STEP 5**

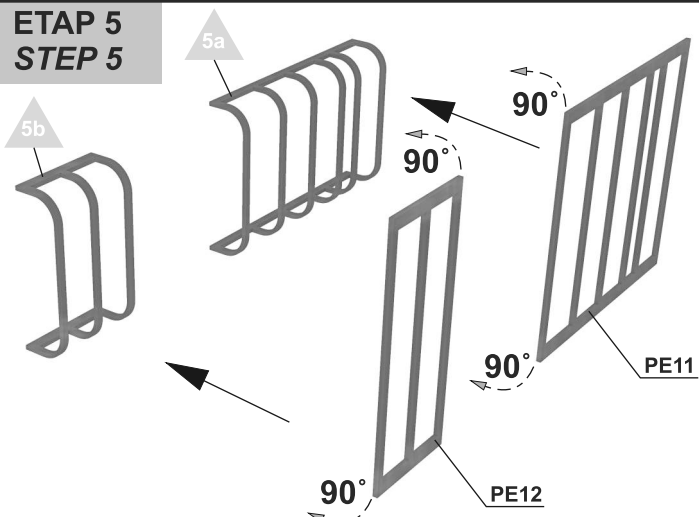

**ETAP 6
STEP 6**

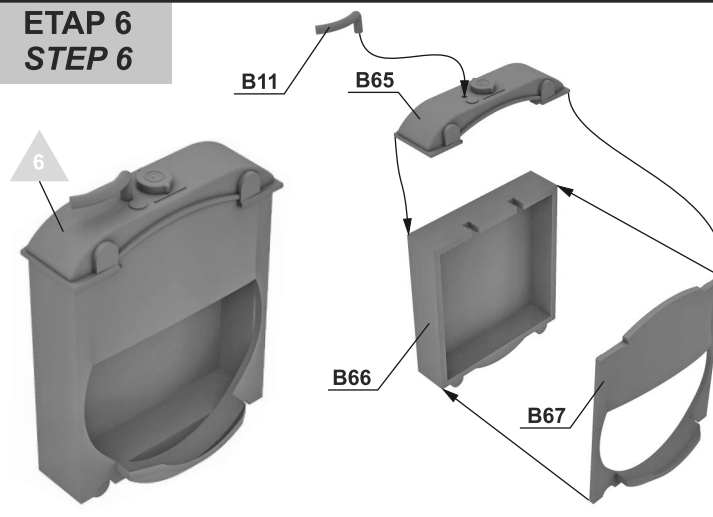

**ETAP 7
STEP 7**

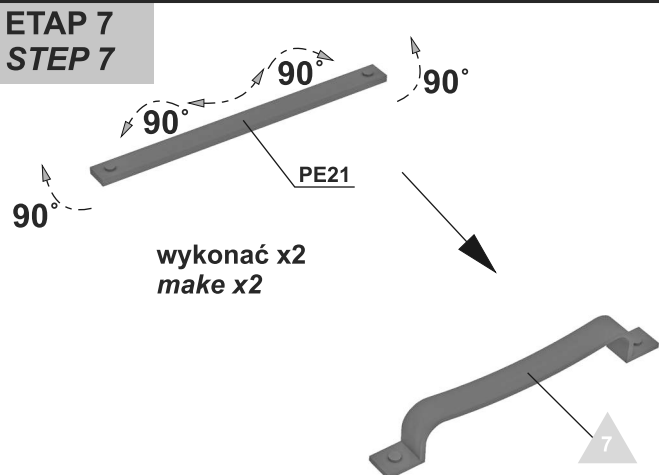

**ETAP 8
STEP 8**

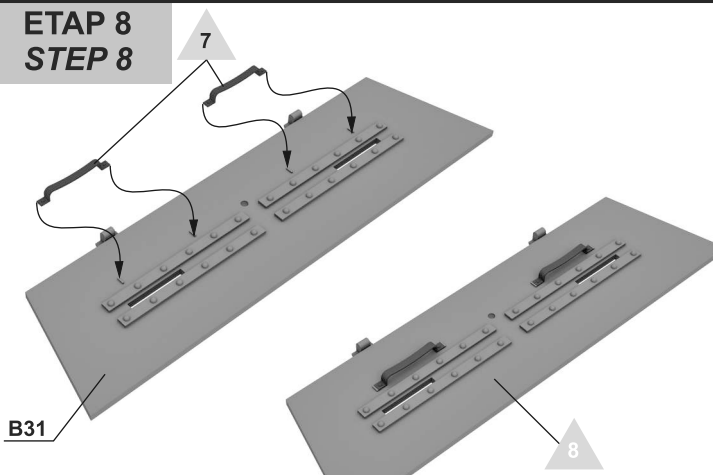

**ETAP 9
STEP 9**

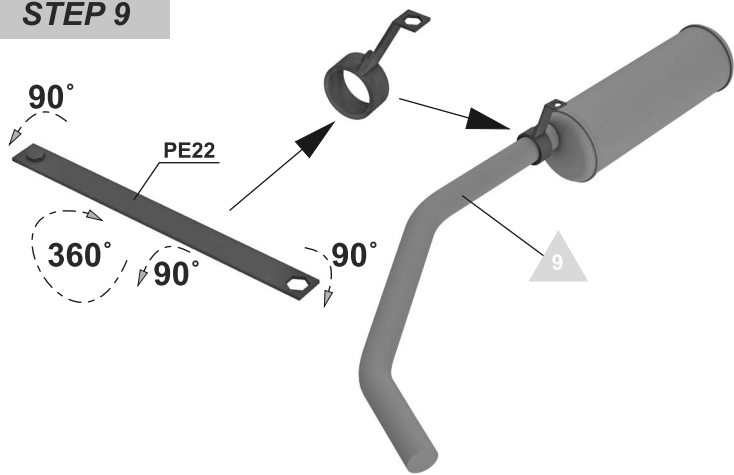

**ETAP 10
STEP 10**

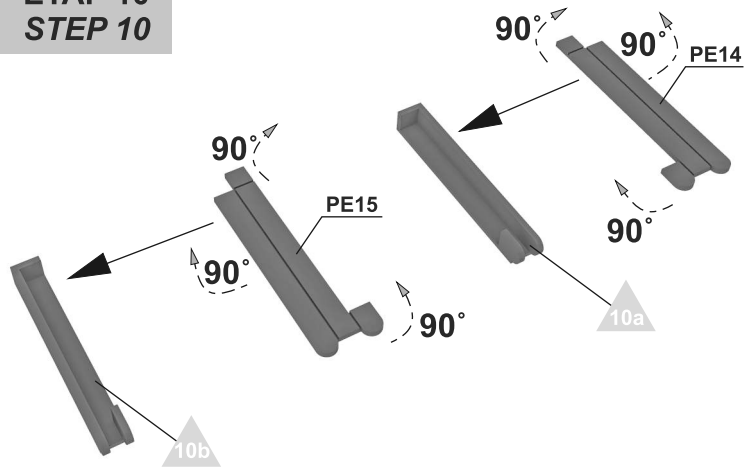

**ETAP 11
STEP 11**

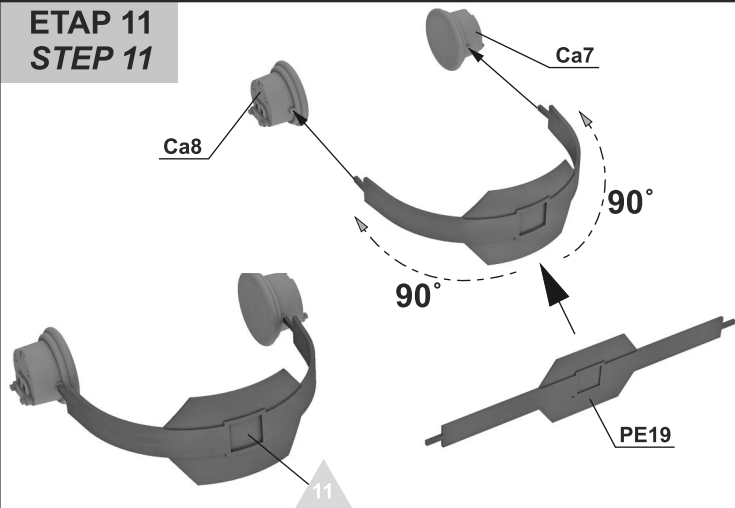

**ETAP 12
STEP 12**

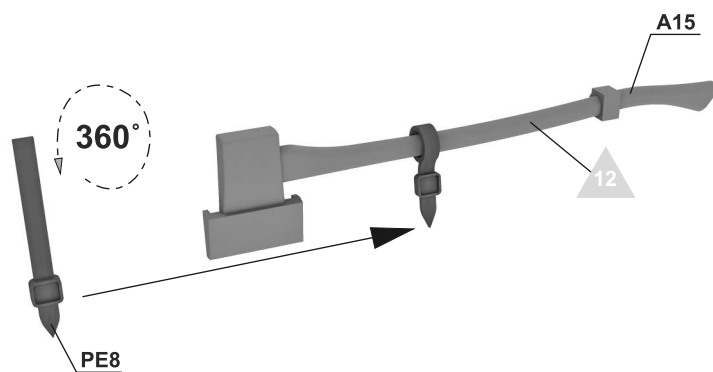

**ETAP 13
STEP 13**

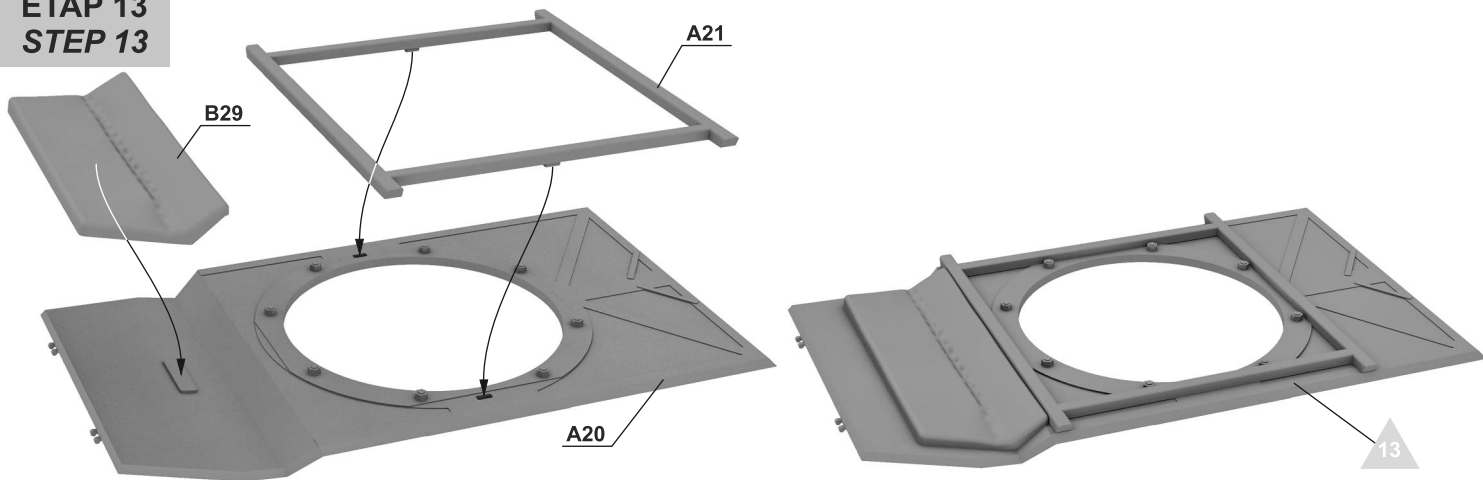

**ETAP 14
STEP 14**

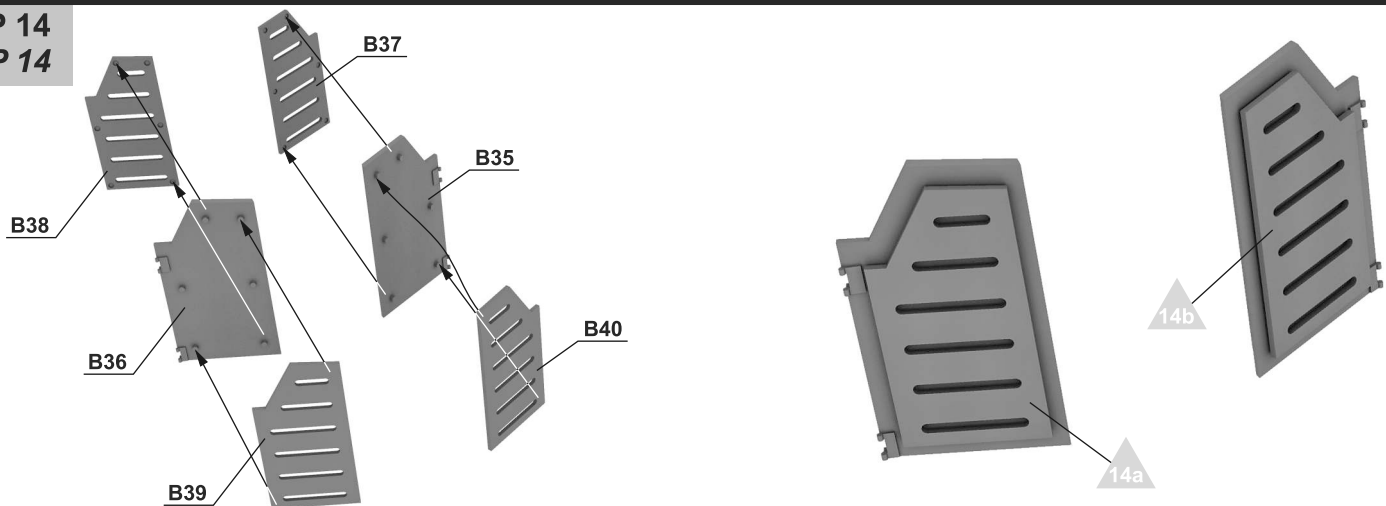

ETAP 15
STEP 15

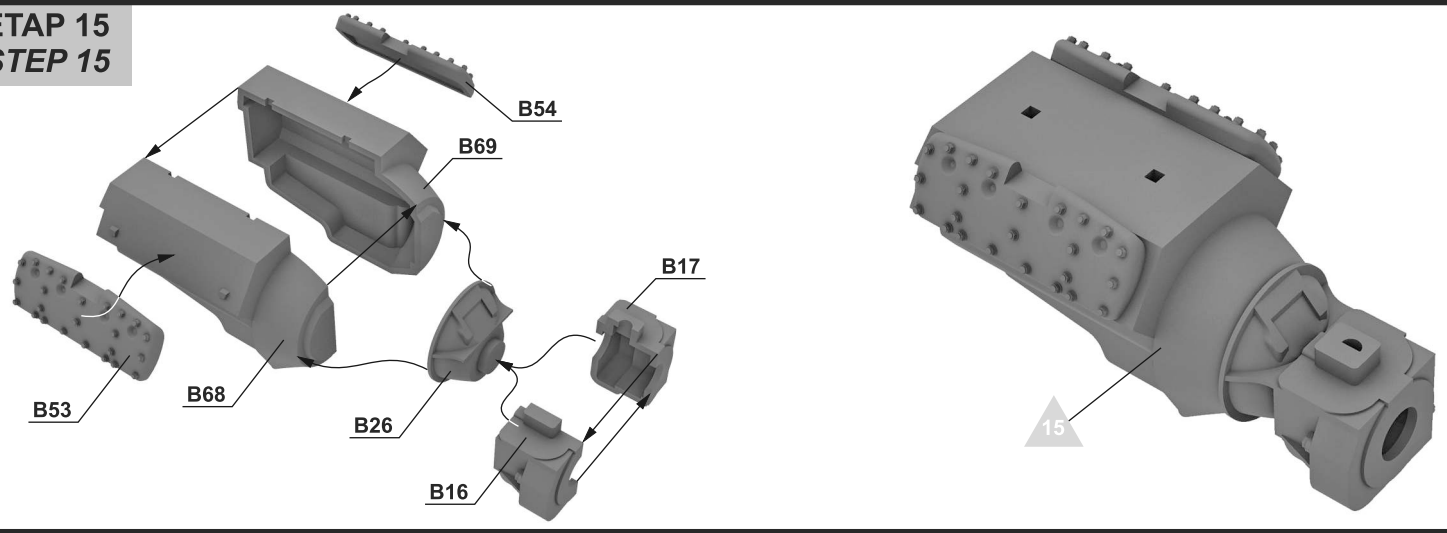

ETAP 16
STEP 16

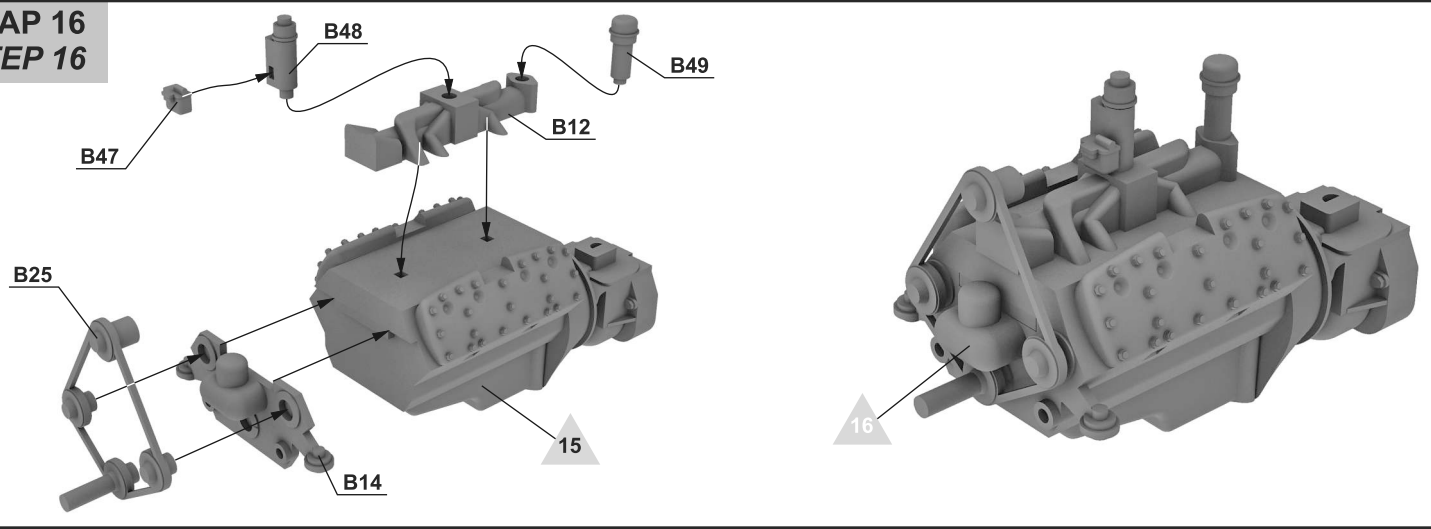

ETAP 17
STEP 17

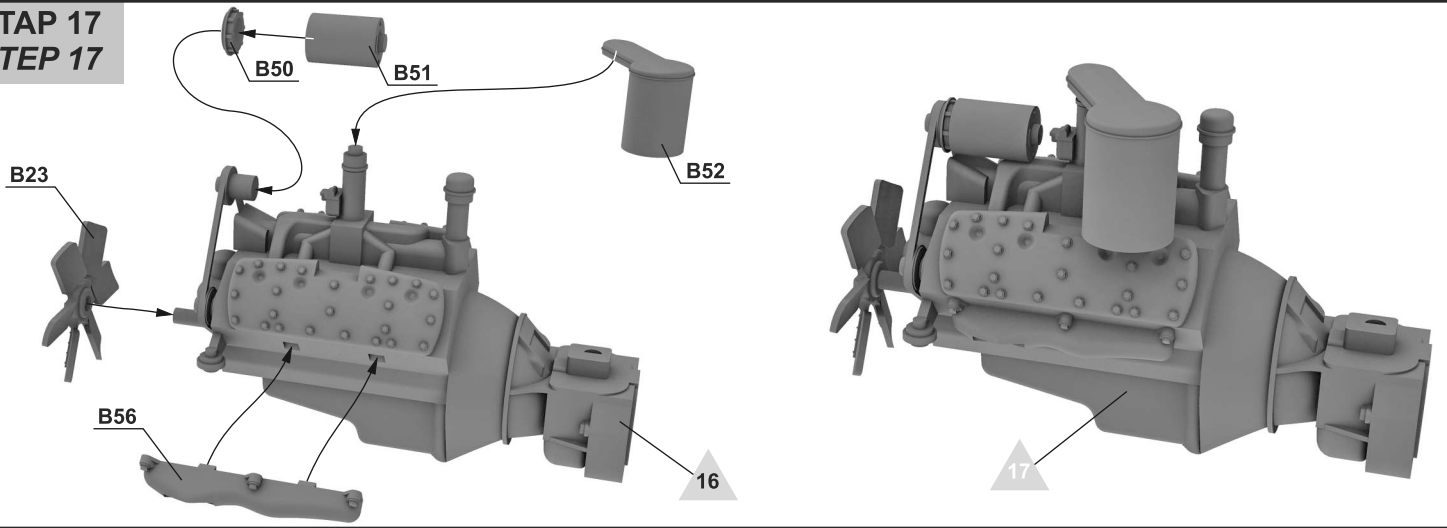

ETAP 18
STEP 18

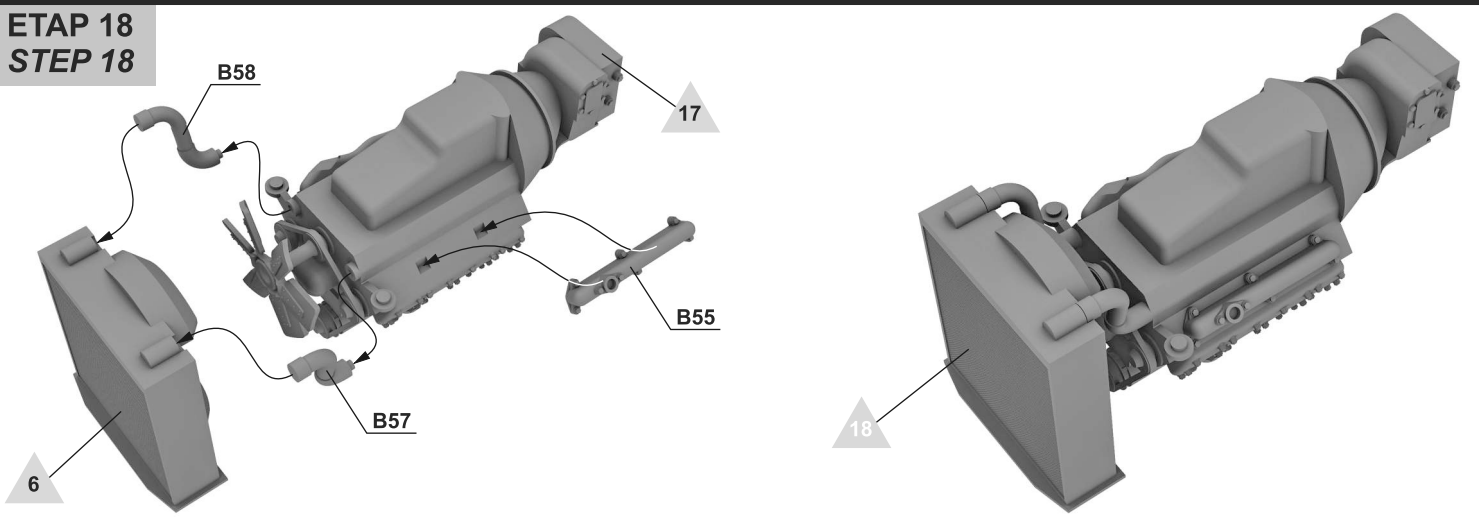

ETAP 19
STEP 19

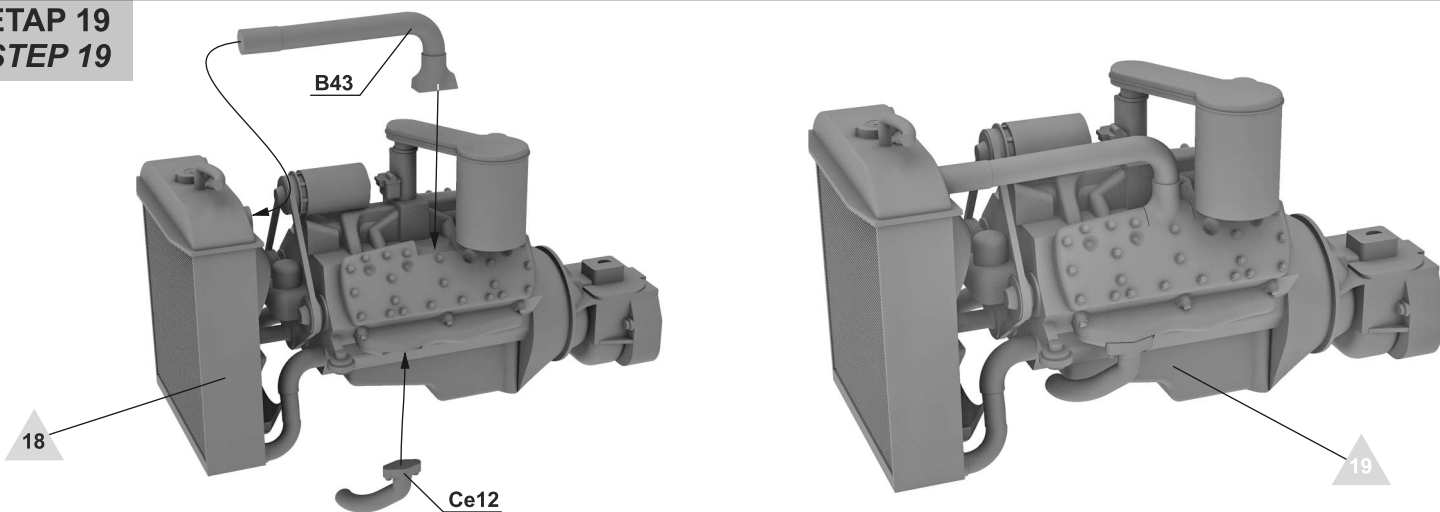

ETAP 20
STEP 20

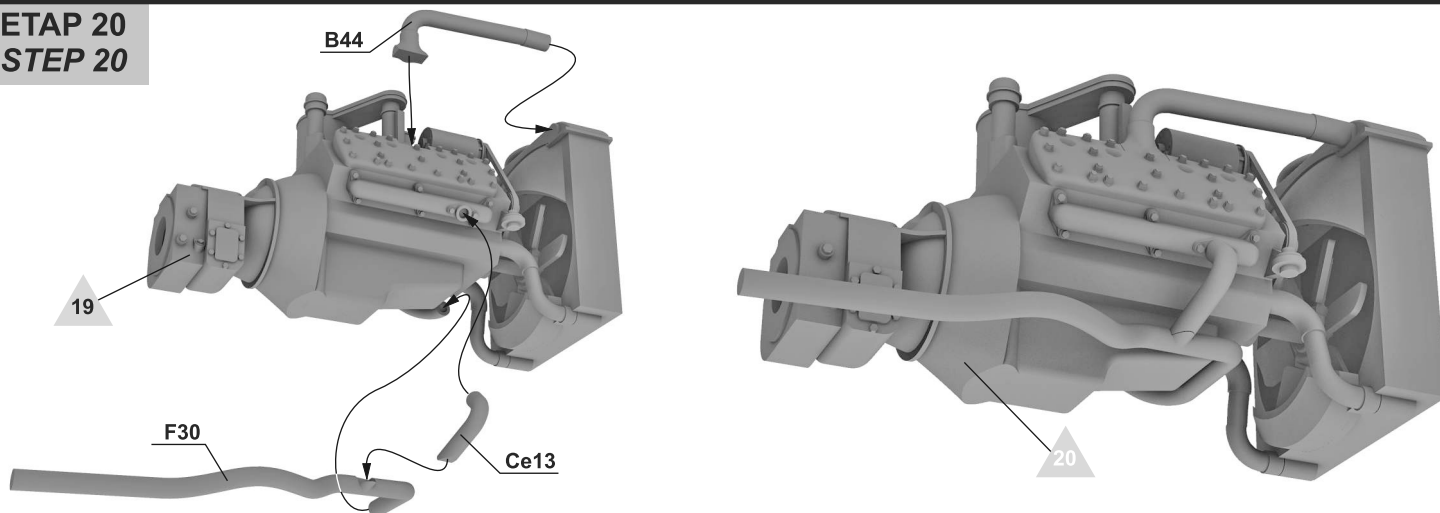

ETAP 21
STEP 21

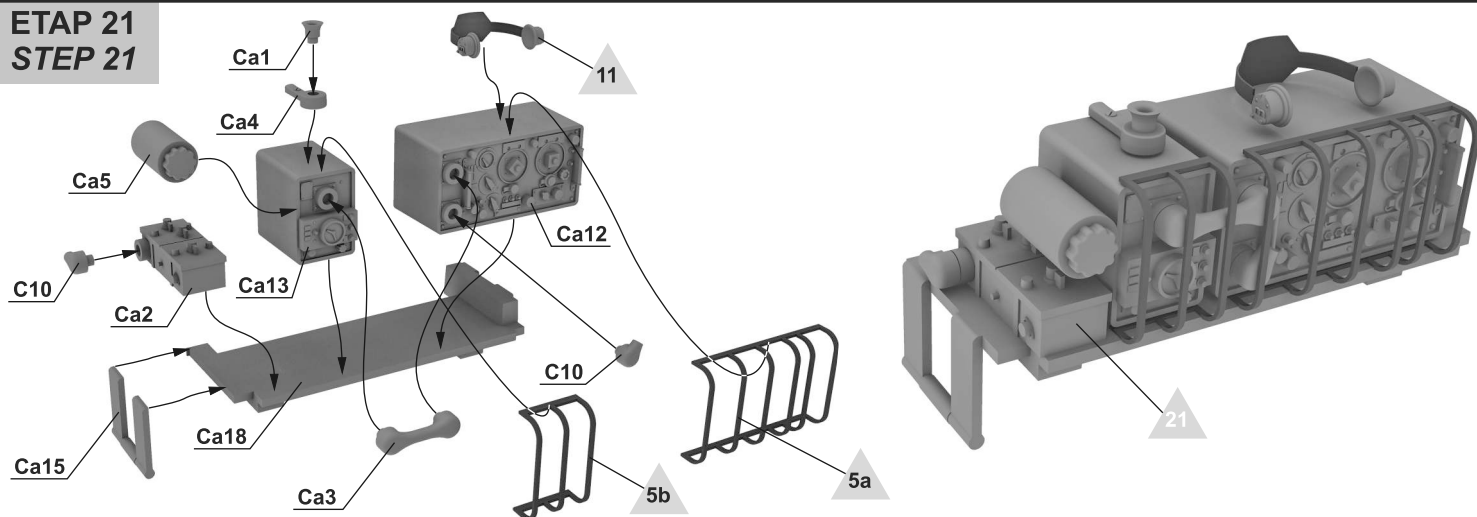

ETAP 22
STEP 22

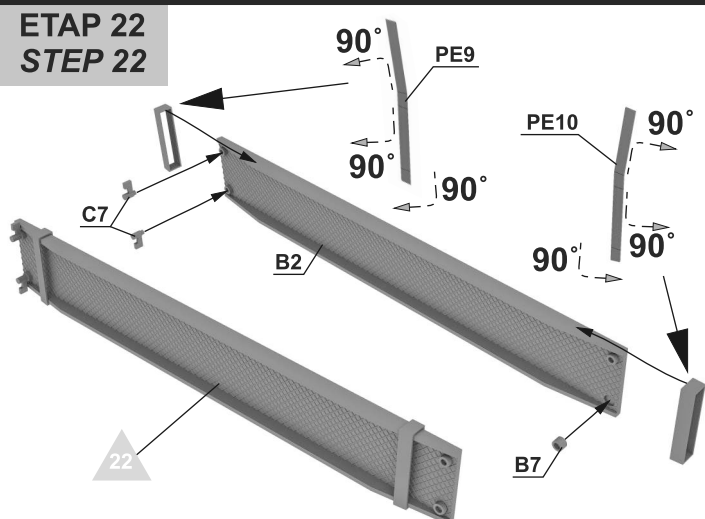

ETAP 23
STEP 23

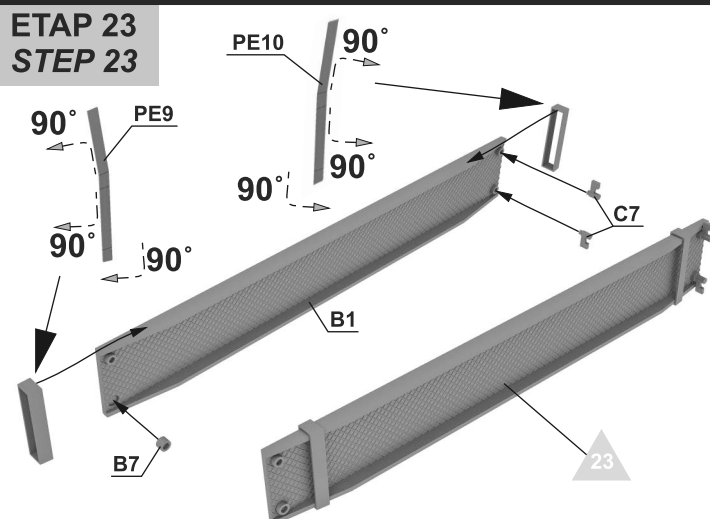

ETAP 24
STEP 24

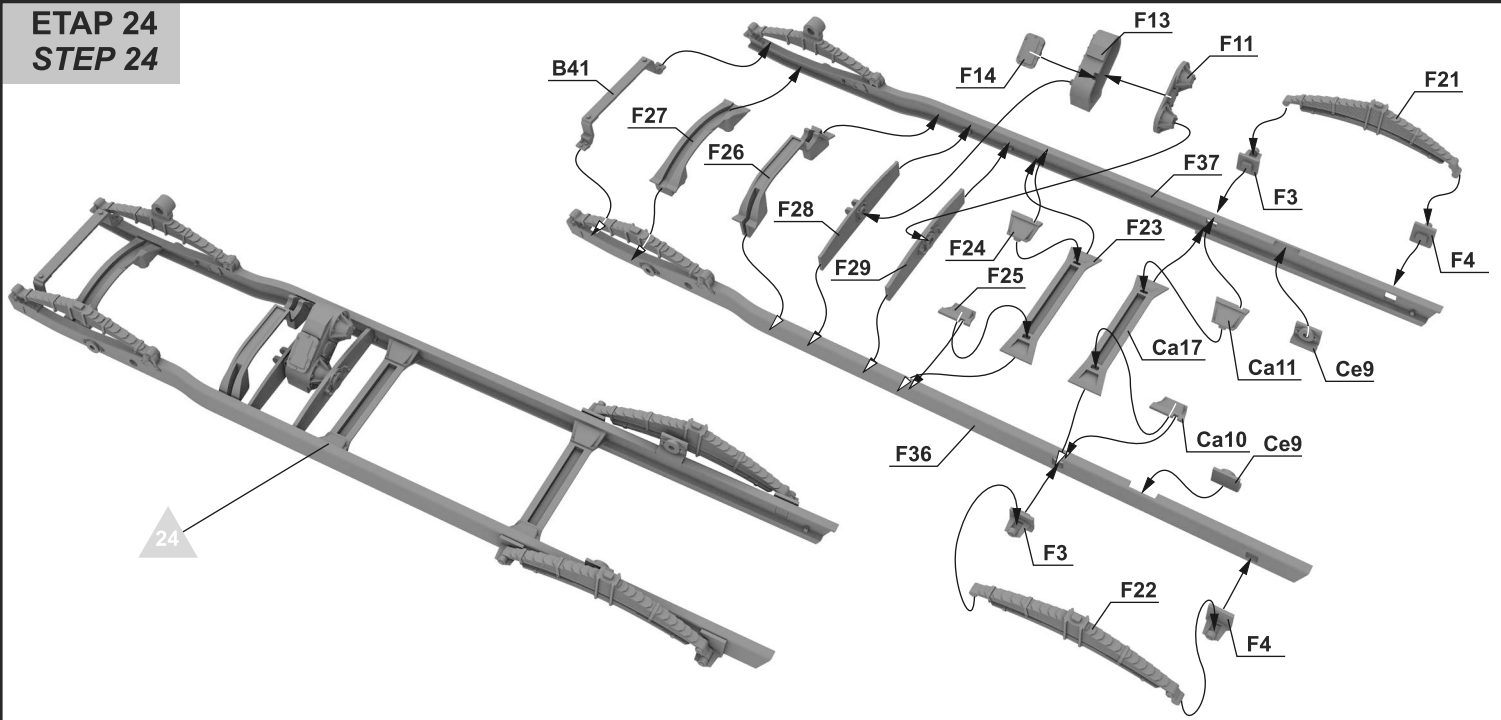

ETAP 25
STEP 25

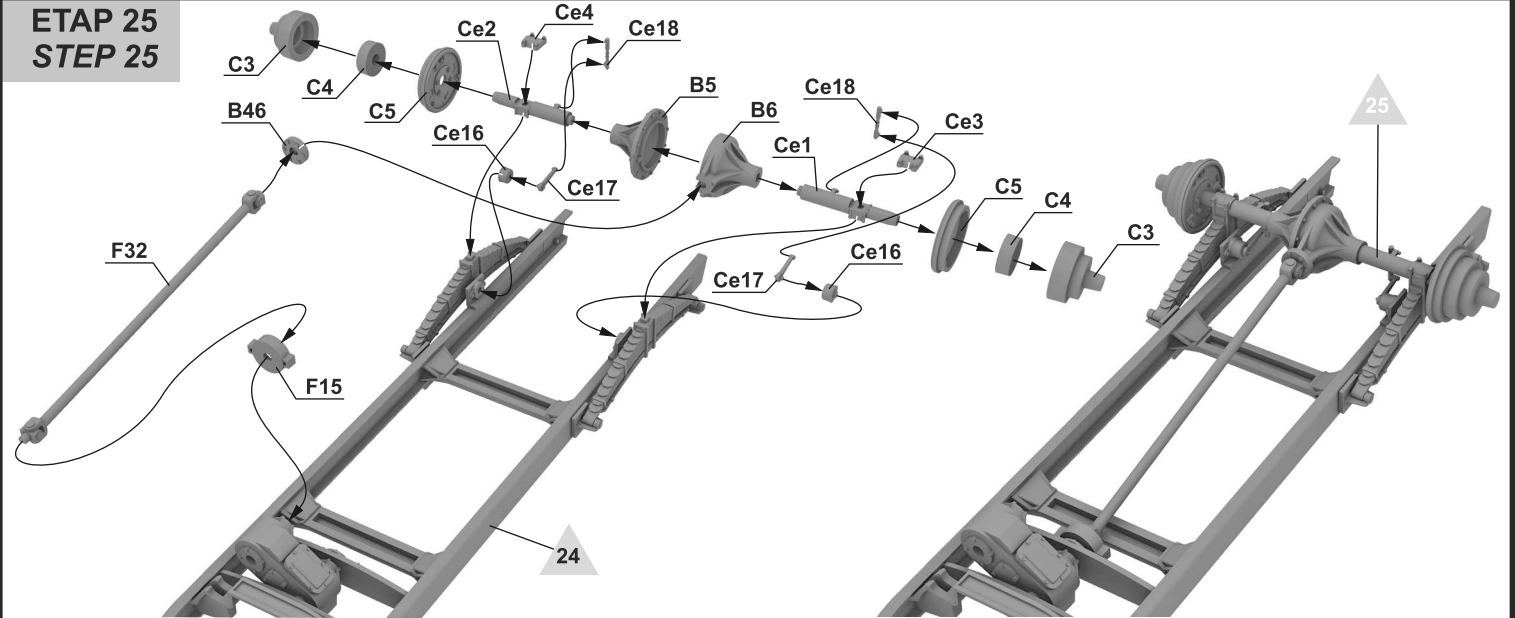

ETAP 26
STEP 26

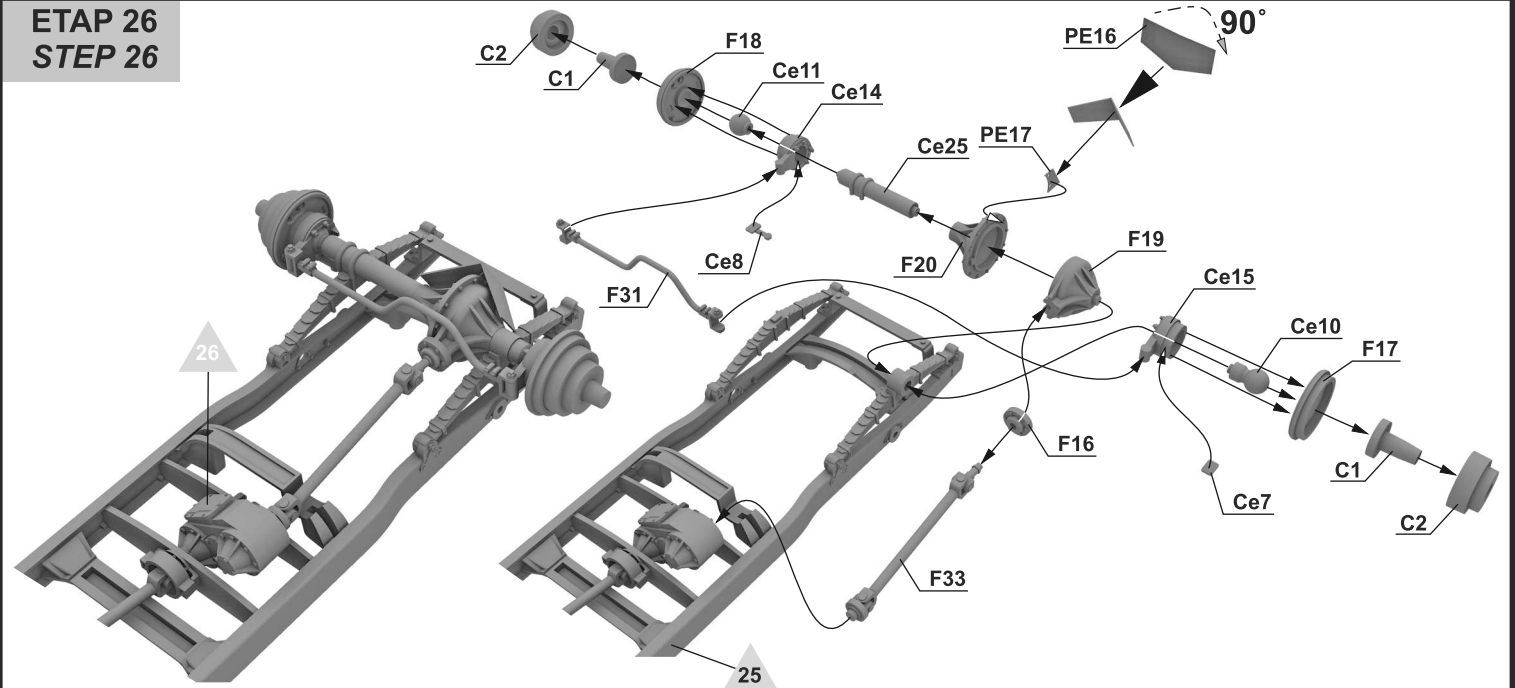

ETAP 27
STEP 27

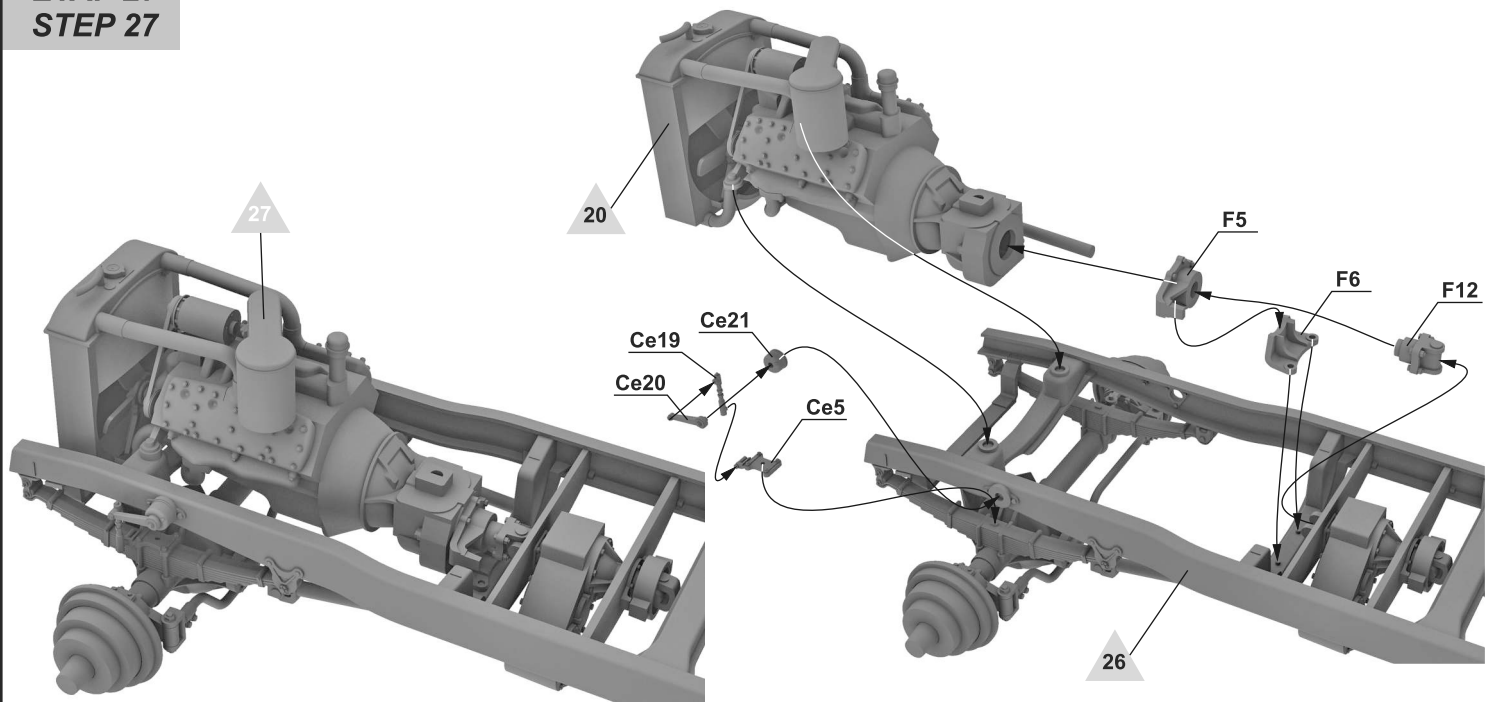

ETAP 28
STEP 28

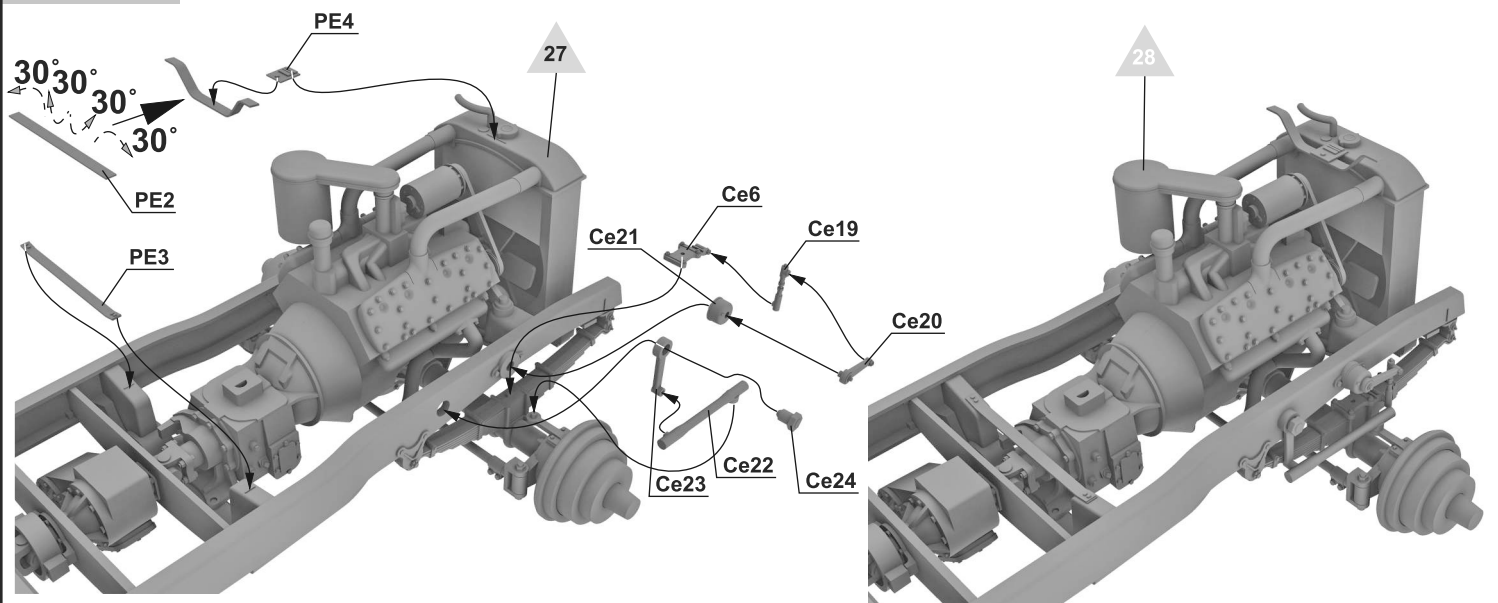

ETAP 29
STEP 29

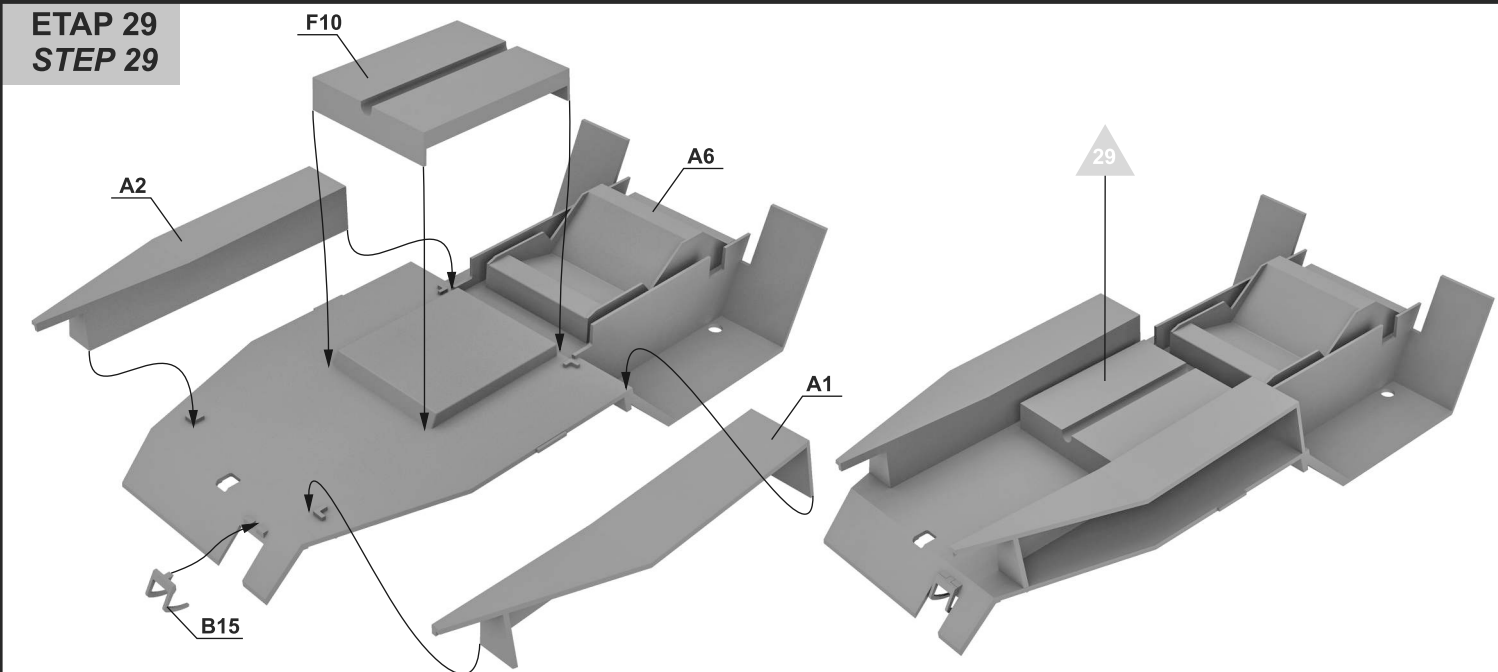

ETAP 30
STEP 30

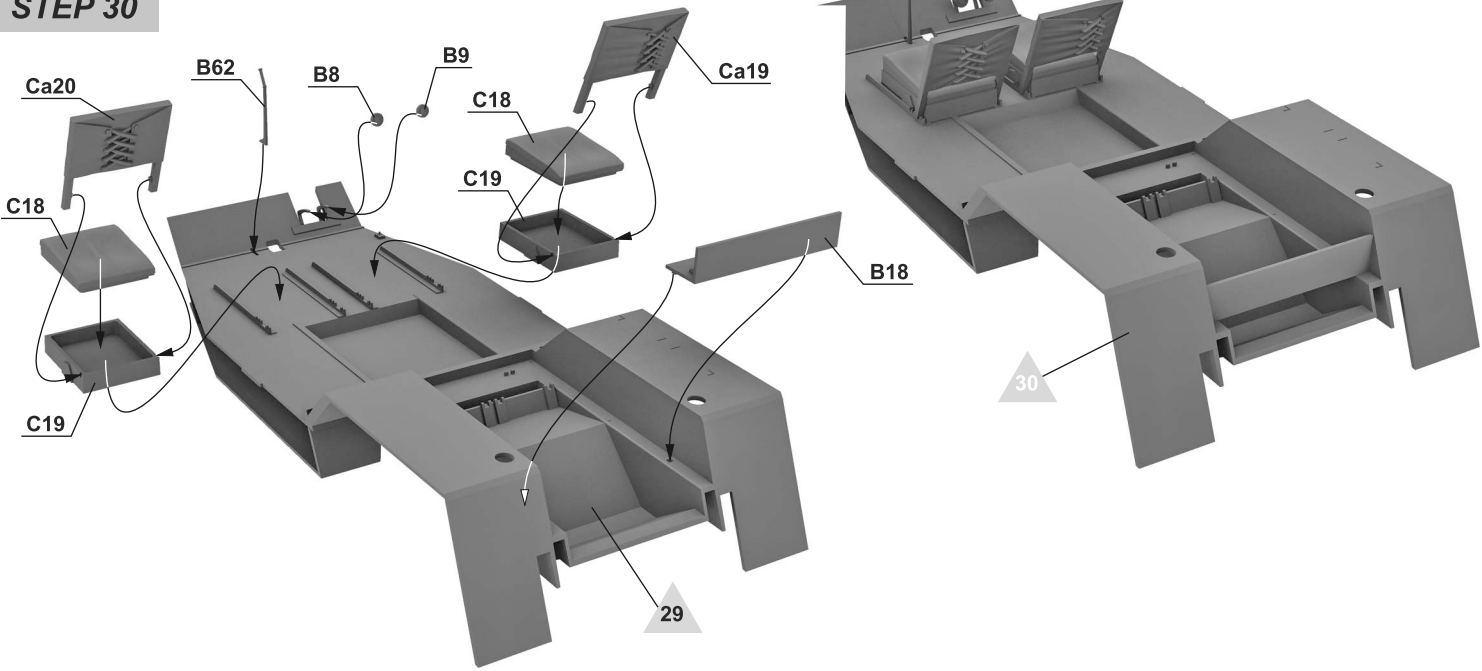

ETAP 31
STEP 31

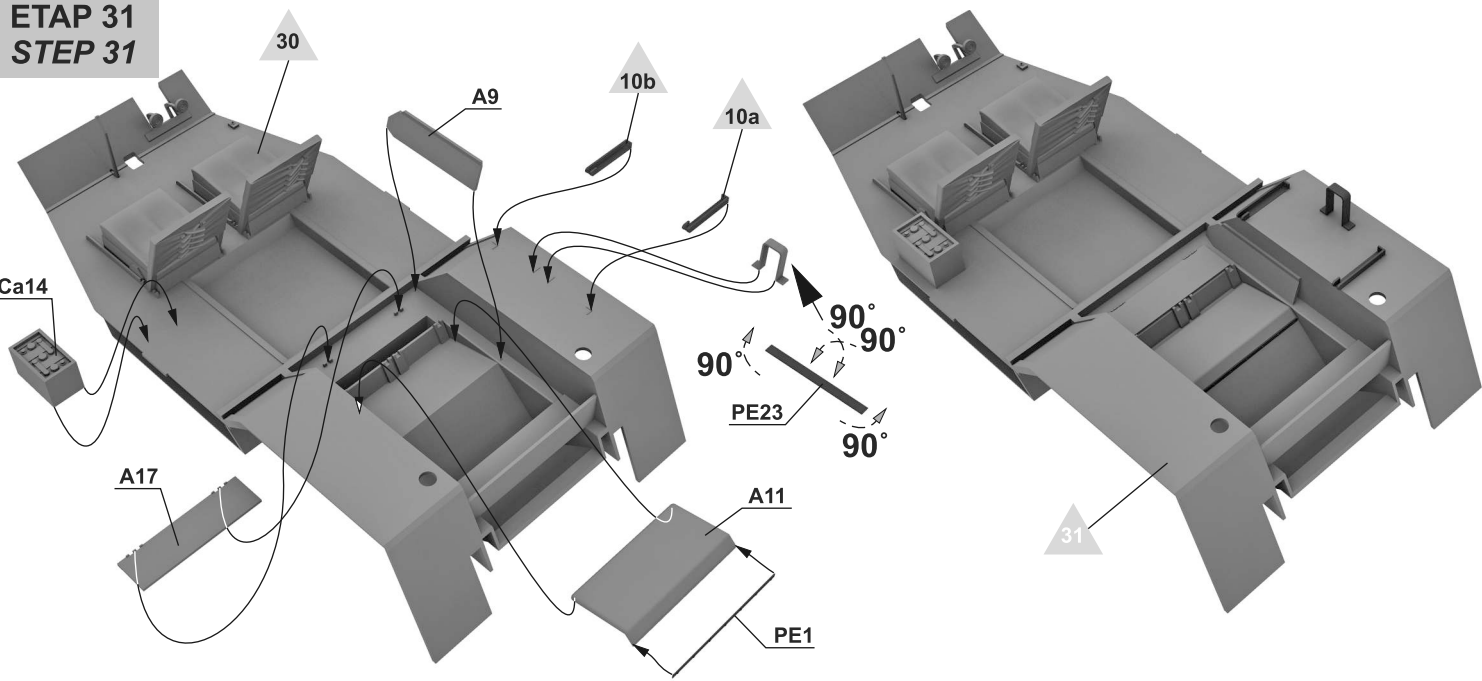

ETAP 32
STEP 32

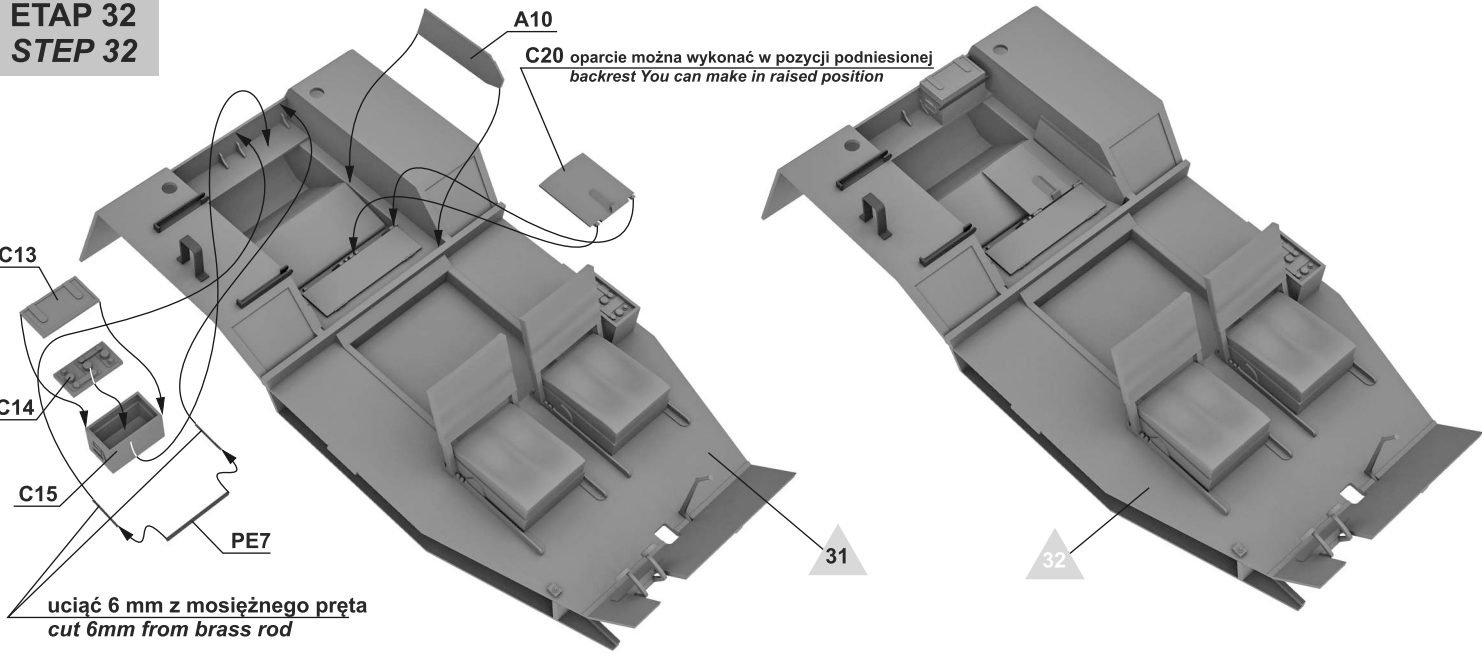

**ETAP 33
STEP 33**

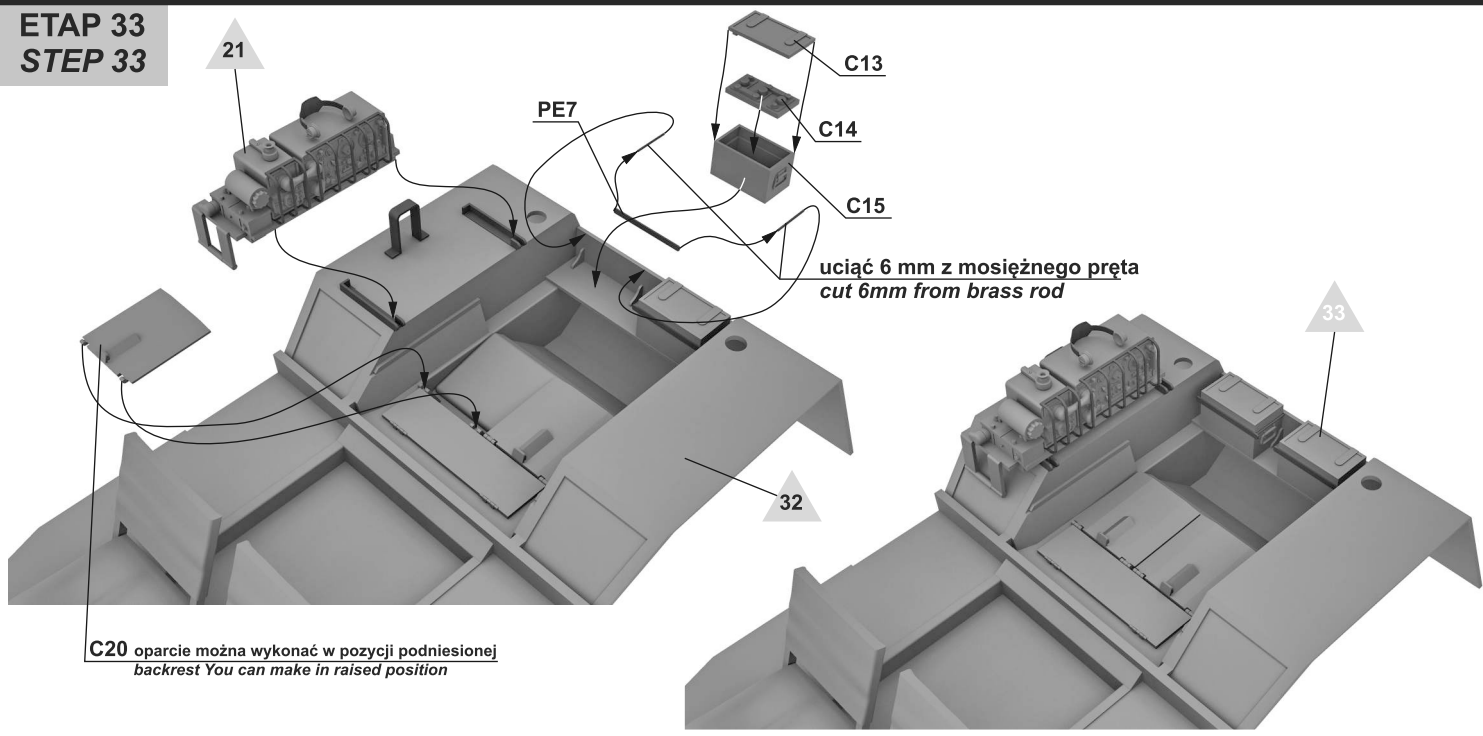

**ETAP 34
STEP 34**

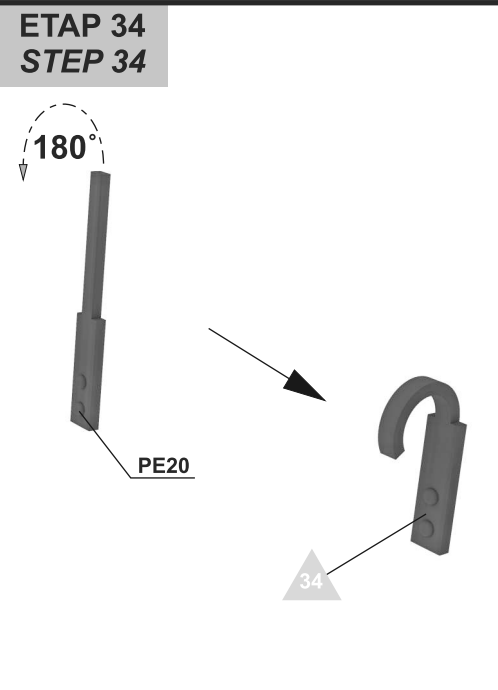

**ETAP 35
STEP 35**

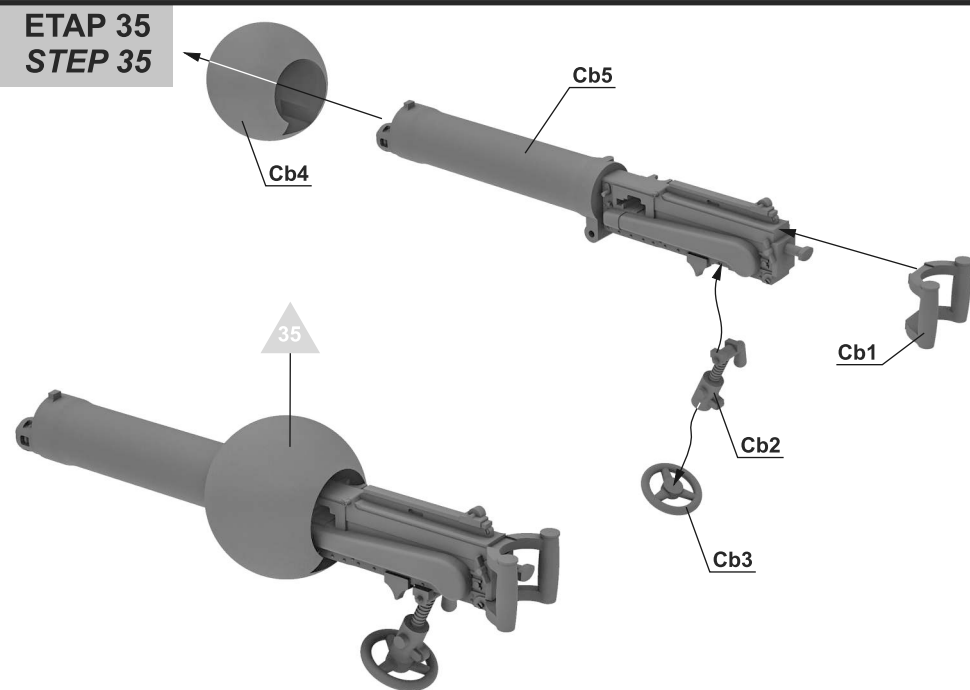

**ETAP 36
STEP 36**

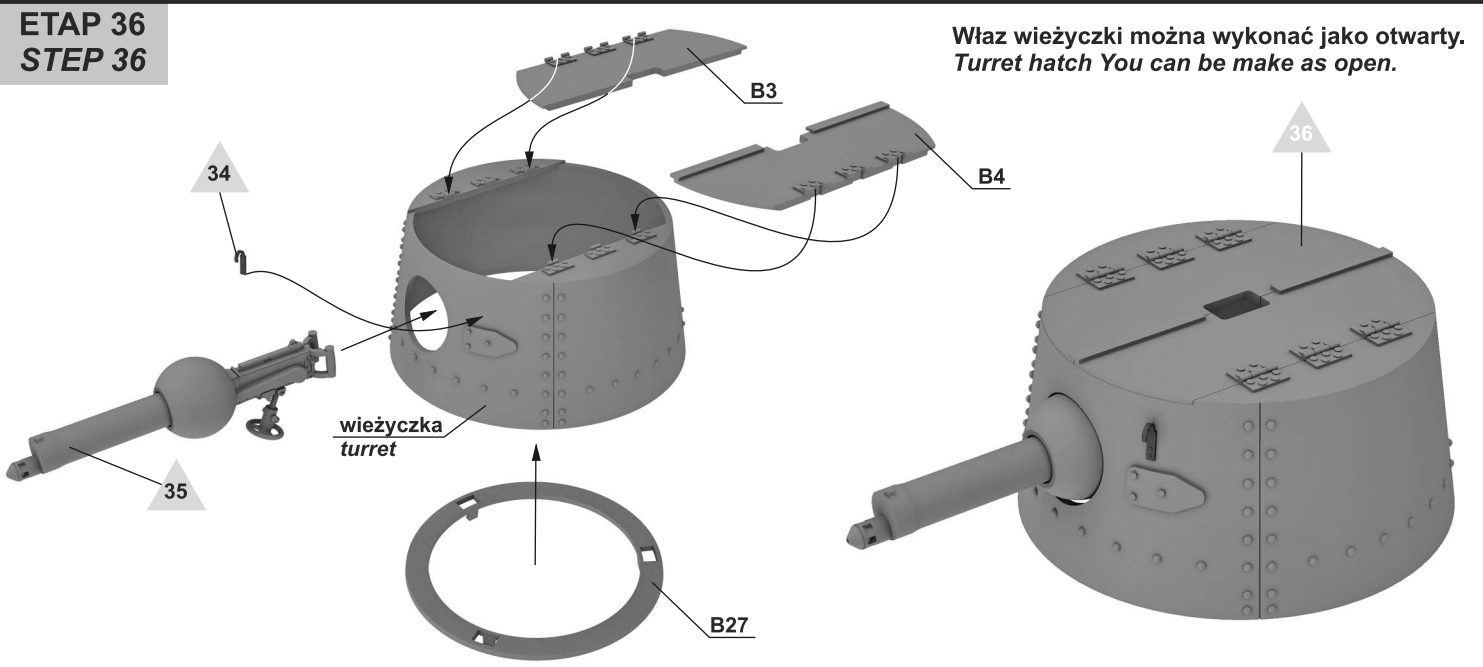

ETAP 37
STEP 37

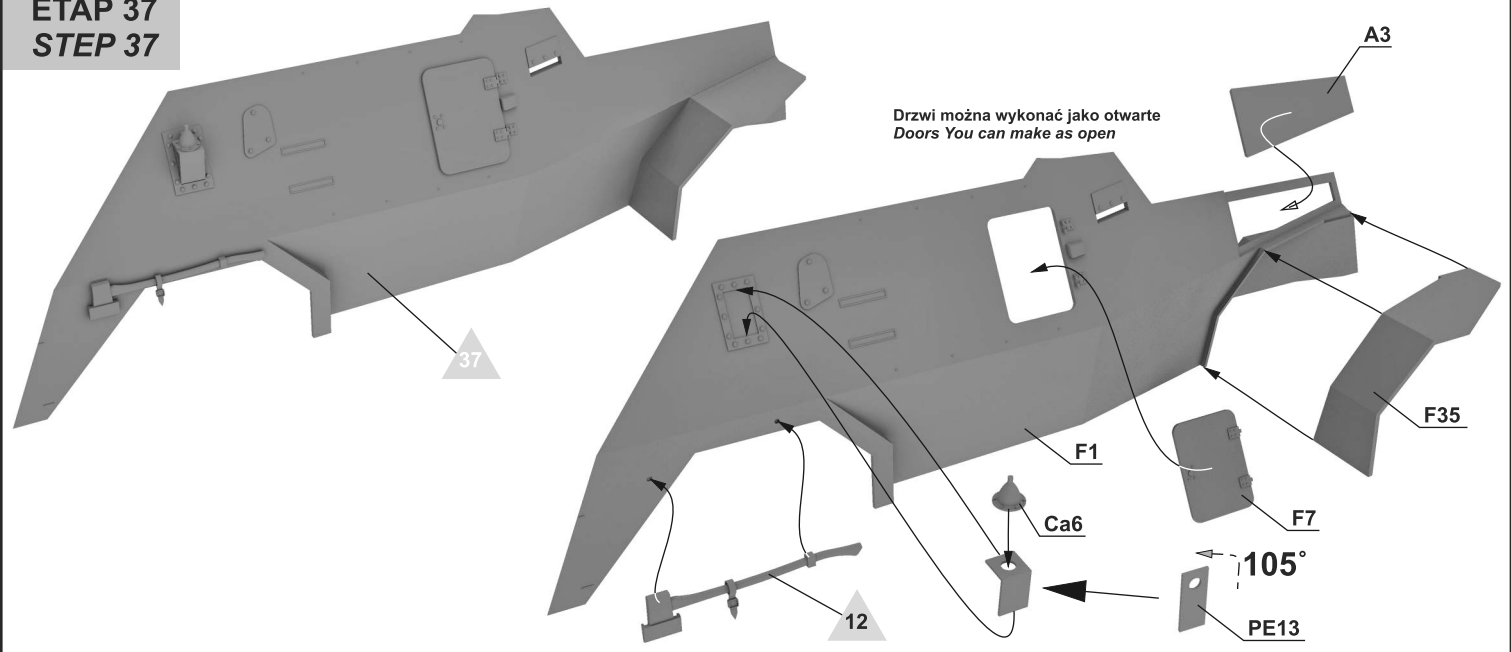

ETAP 38
STEP 38

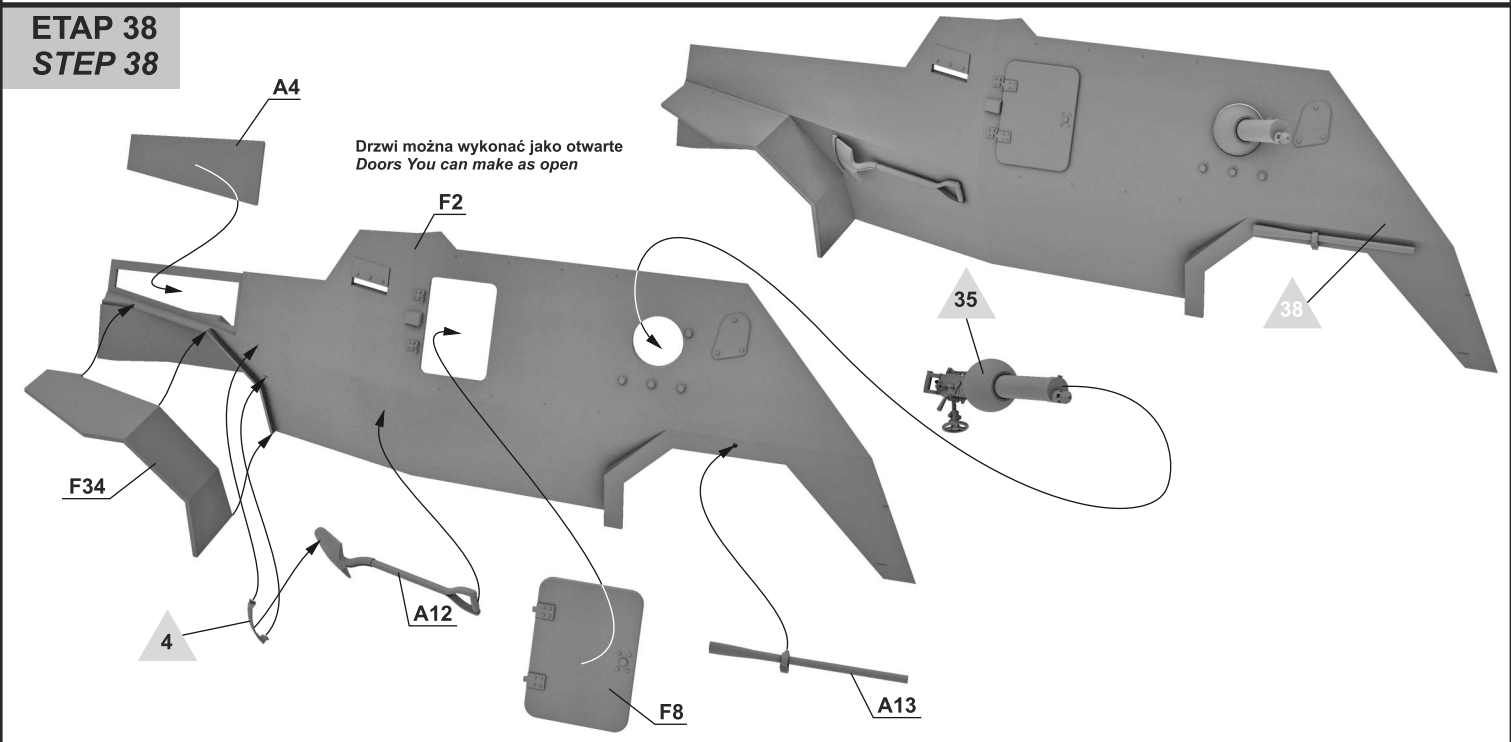

ETAP 39
STEP 39

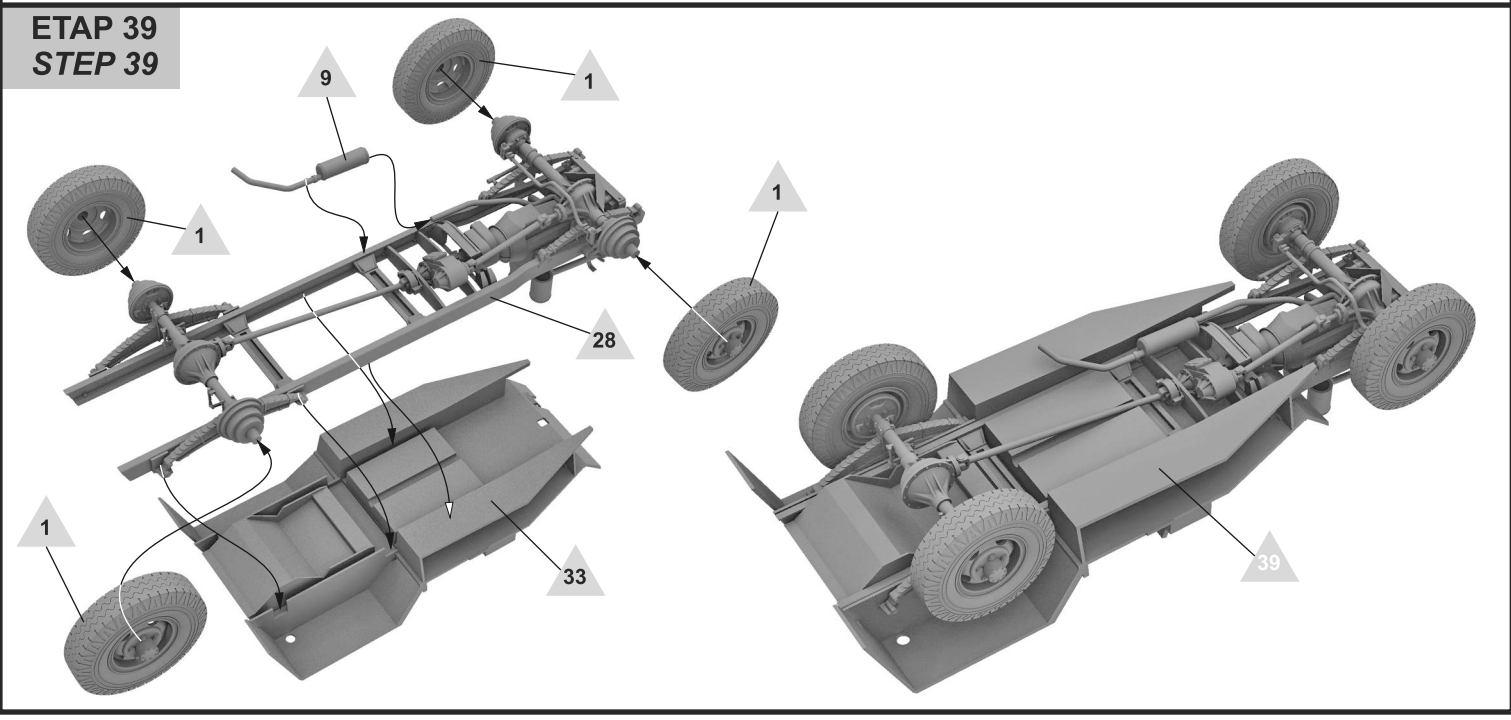

ETAP 40
STEP 40

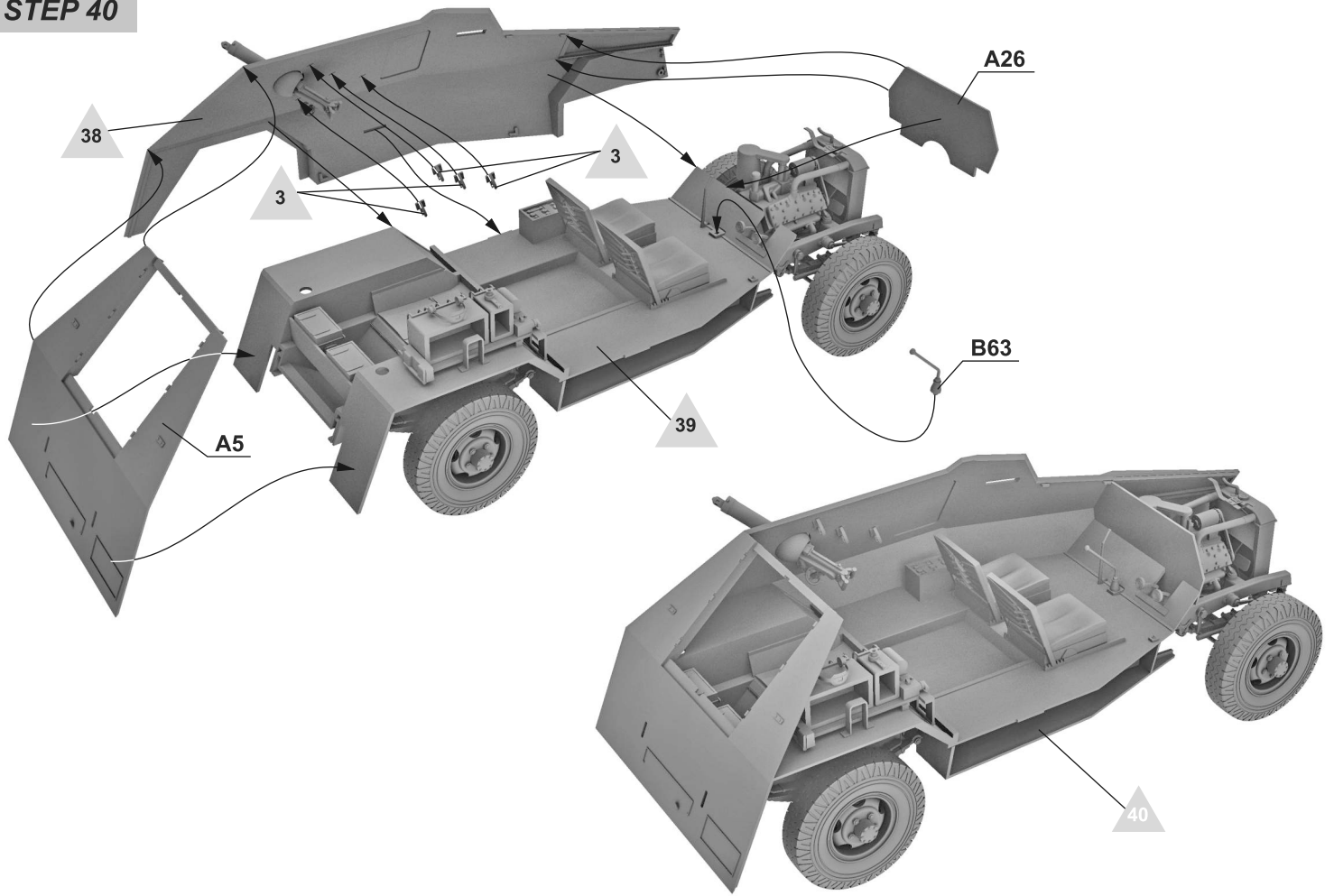

ETAP 41
STEP 41

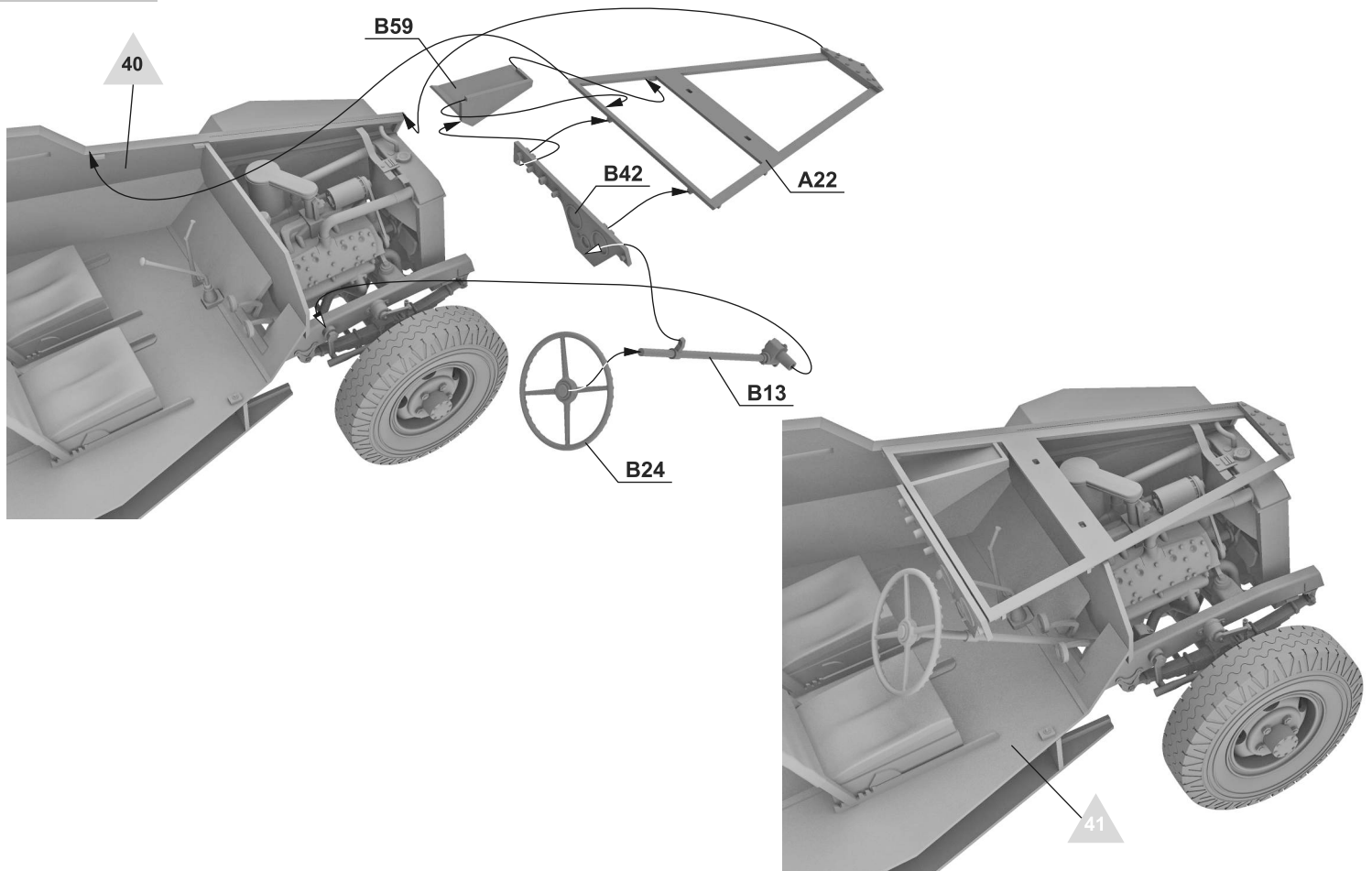

ETAP 42
STEP 42

Dla wersji z otwartymi przednimi włazami silnika użyć części B19 i B20 zamiast B21 i B22.
For version with open front engine doors please use parts B19 & B20 in place of B21 & B22.

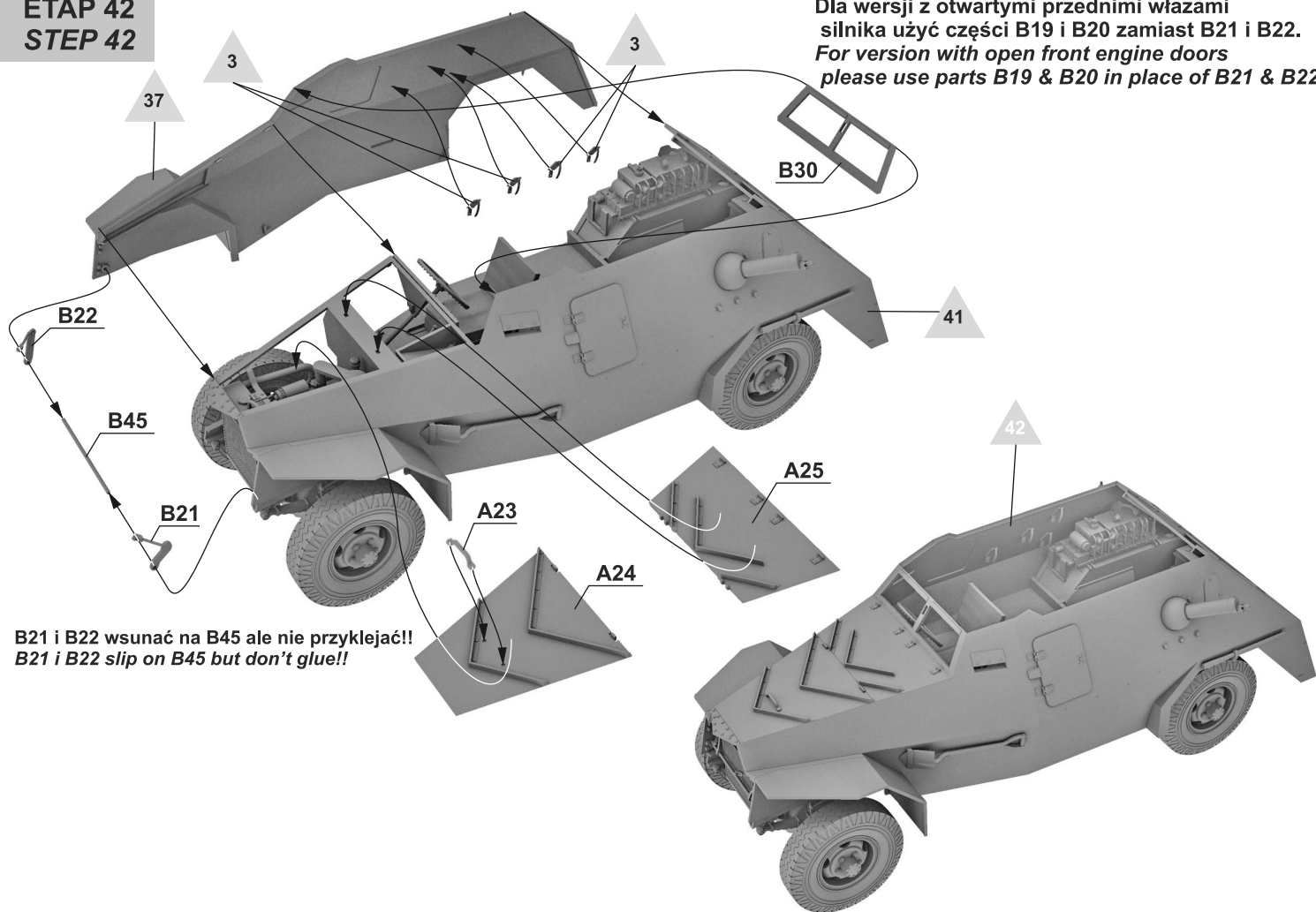

ETAP 43
STEP 43

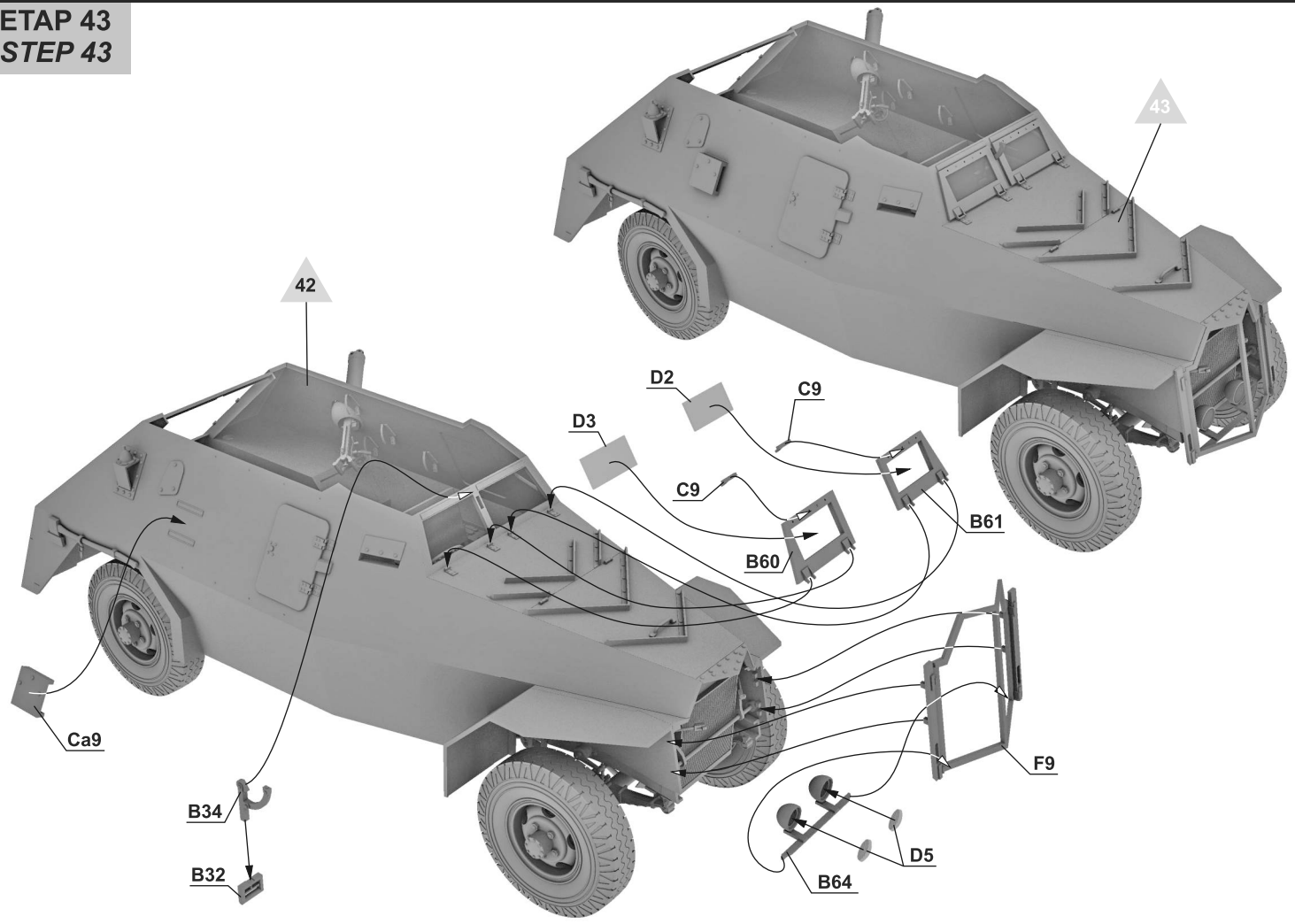

ETAP 44
STEP 44

Tylne drzwi można wykonać jako otwarte.
Rear doors You can make as open.

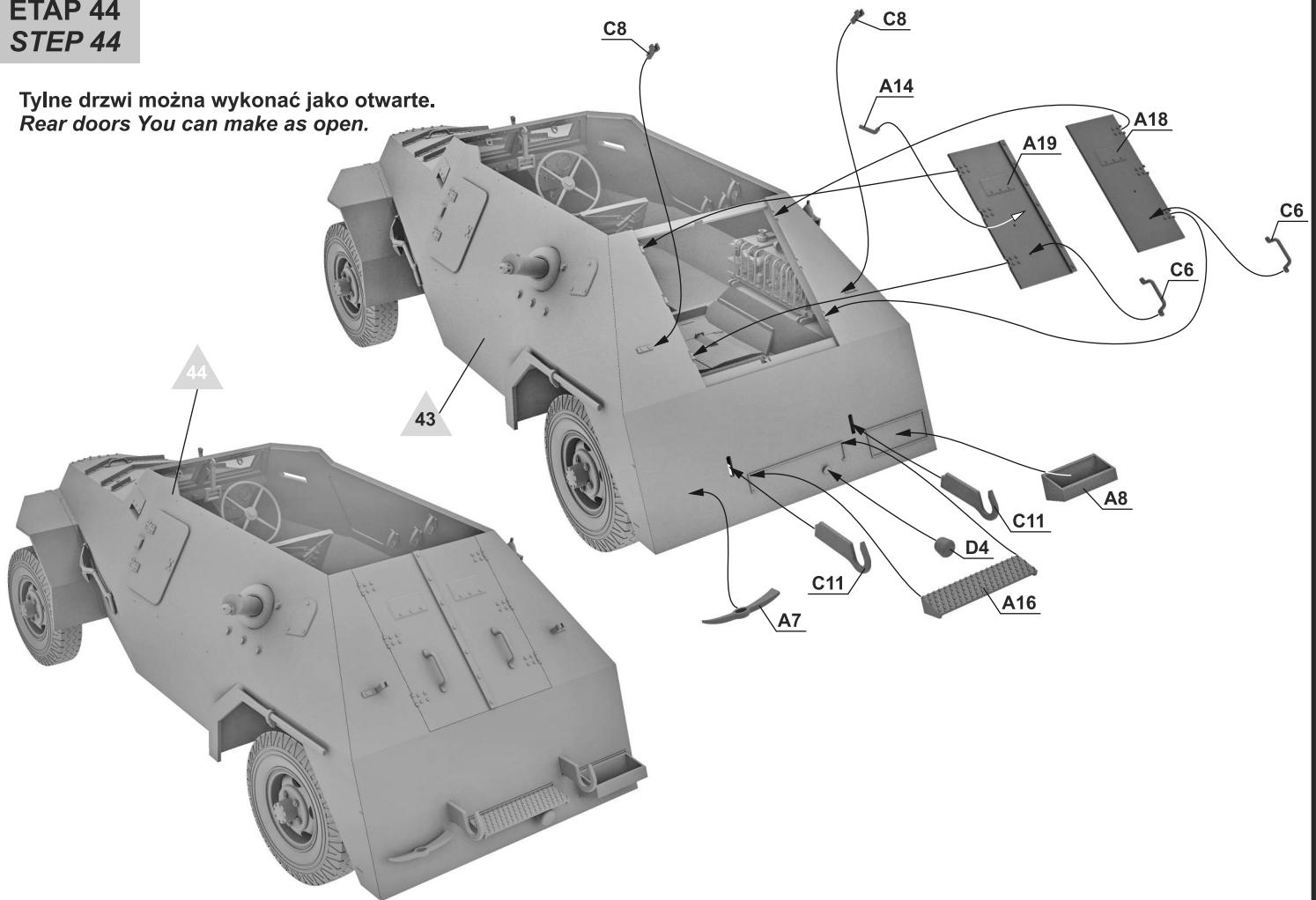

ETAP 45
STEP 45

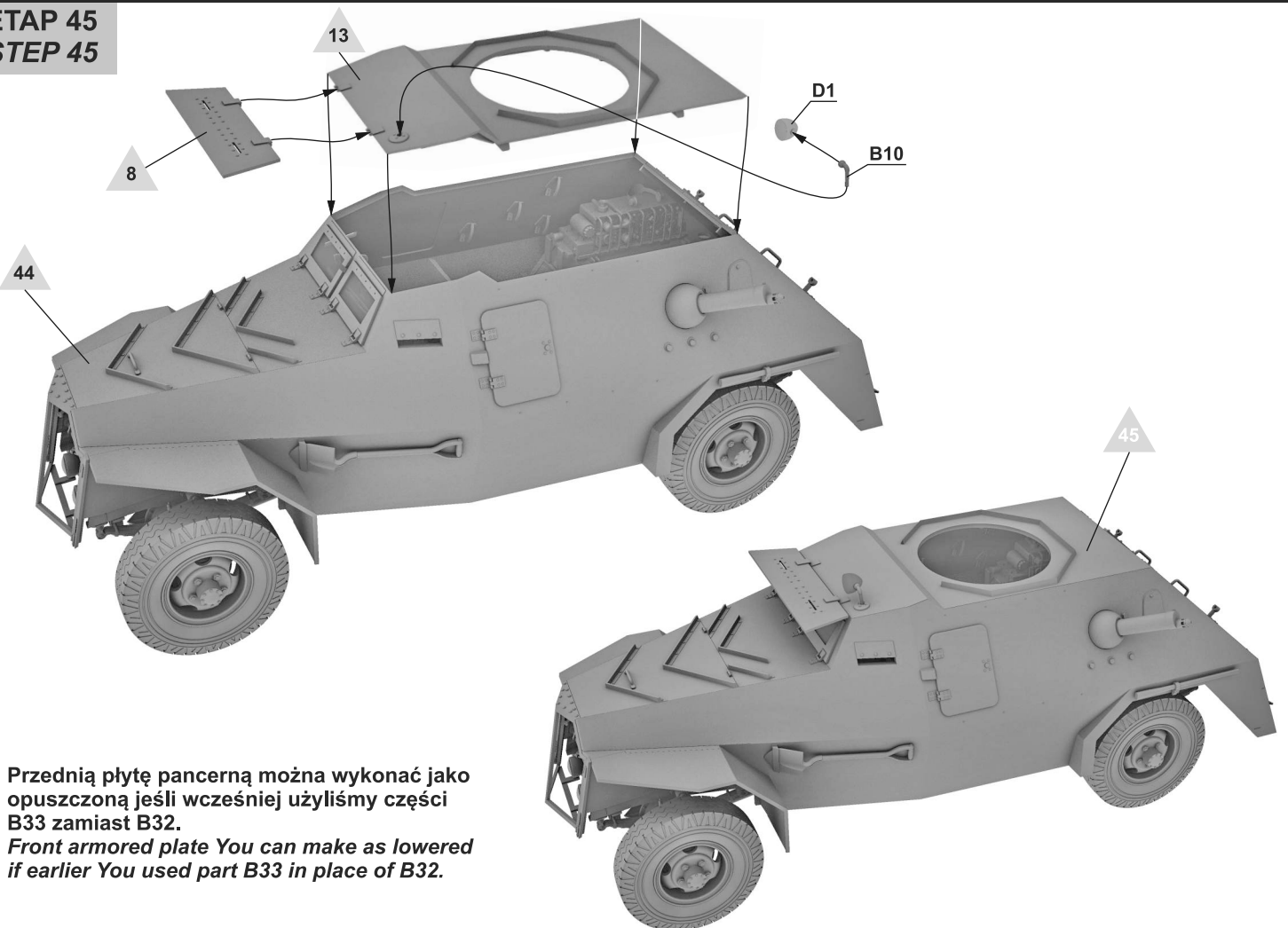

Przednią płytę pancerną można wykonać jako opuszczoną jeśli wcześniej użyliśmy części B33 zamiast B32.
Front armored plate You can make as lowered if earlier You used part B33 in place of B32.

ETAP 46
STEP 46

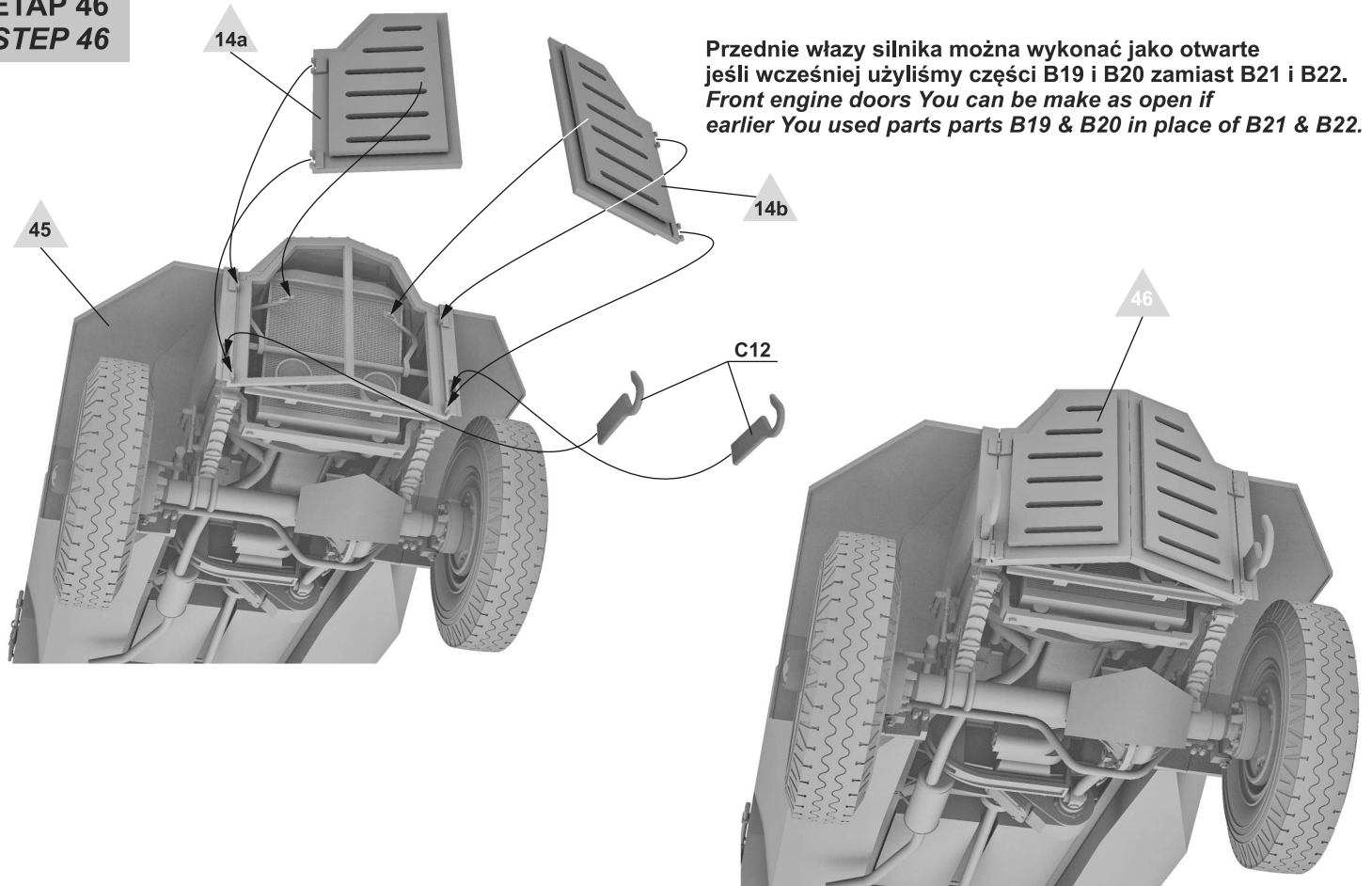

ETAP 47
STEP 47

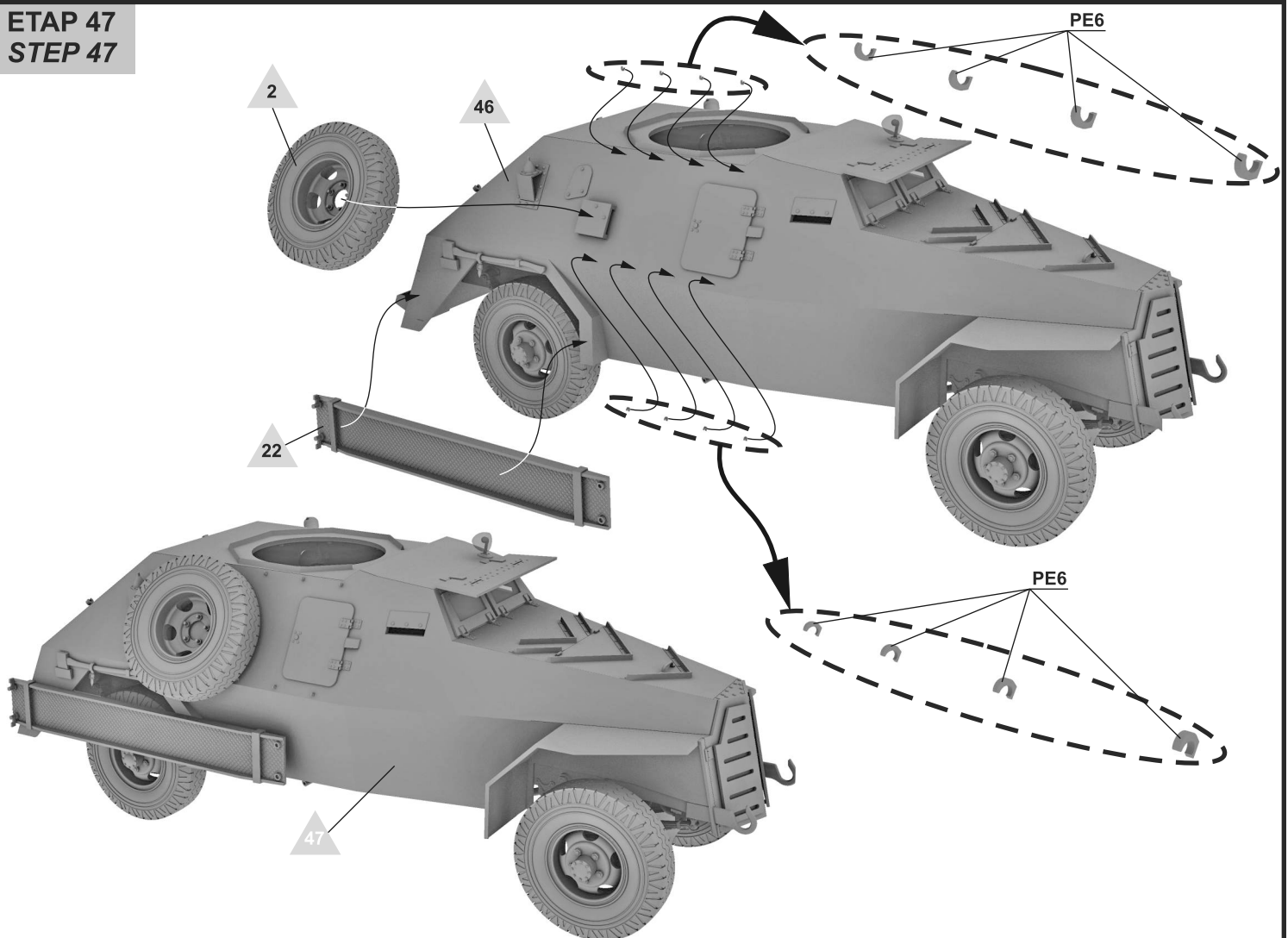

ETAP 48
STEP 48

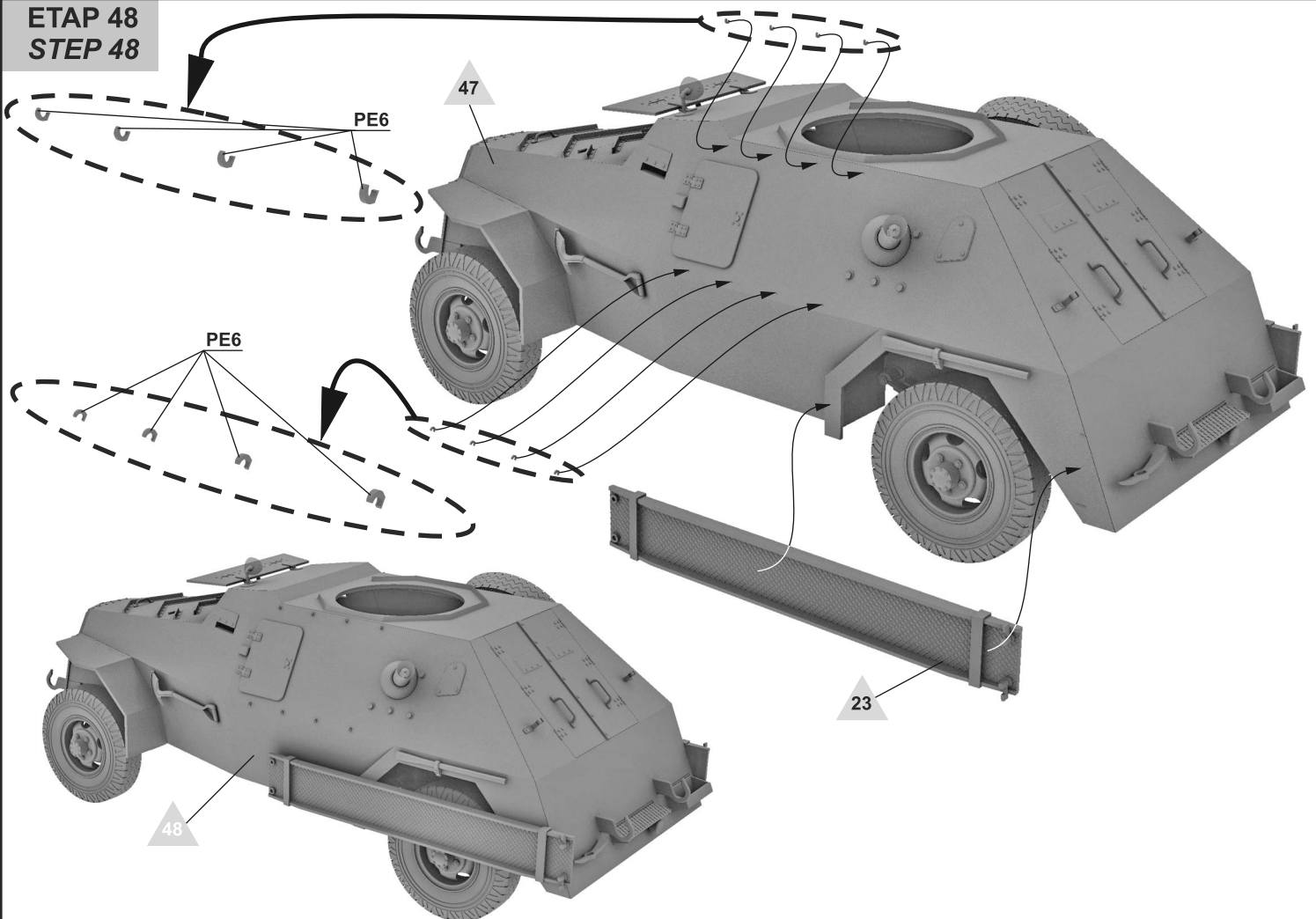

ETAP 49
STEP 49

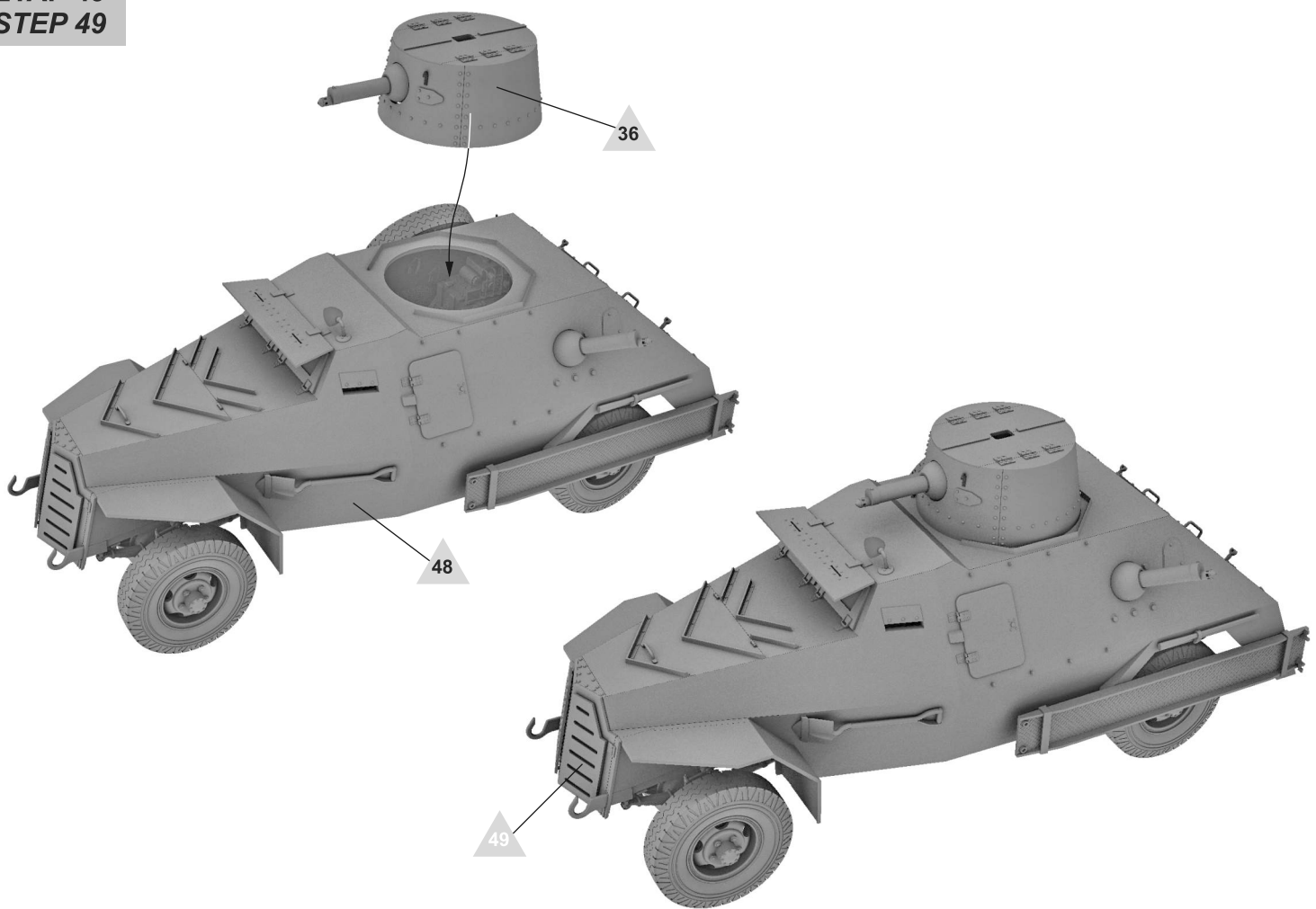

**WYKONANY MODEL
FINISHED MODEL**

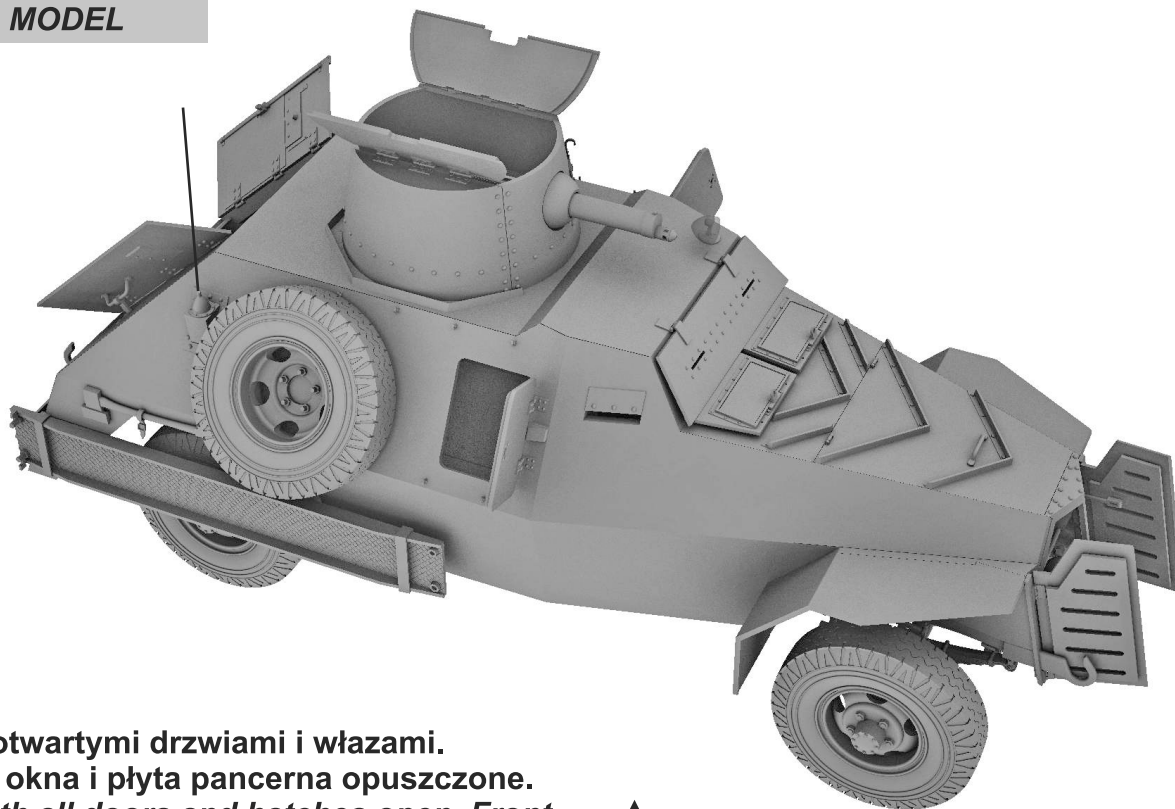

**Model z otwartymi drzwiami i włazami.
Przednie okna i płyta pancerna opuszczone.
*Model with all doors and hatches open. Front
windows and armored plate lowered.***

**Antenę można wykonać z drutu lub
rozciągniętej nad ogniem plastikowej ramki.
*Antenna can be done from wire or plastic
sprue stretched over flame.***



**Model z zamkniętymi drzwiami i włazami.
Przednie okna i płyta pancerna podniesione.
*Model with all doors and hatches closed. Front
windows and armored plate raised.***

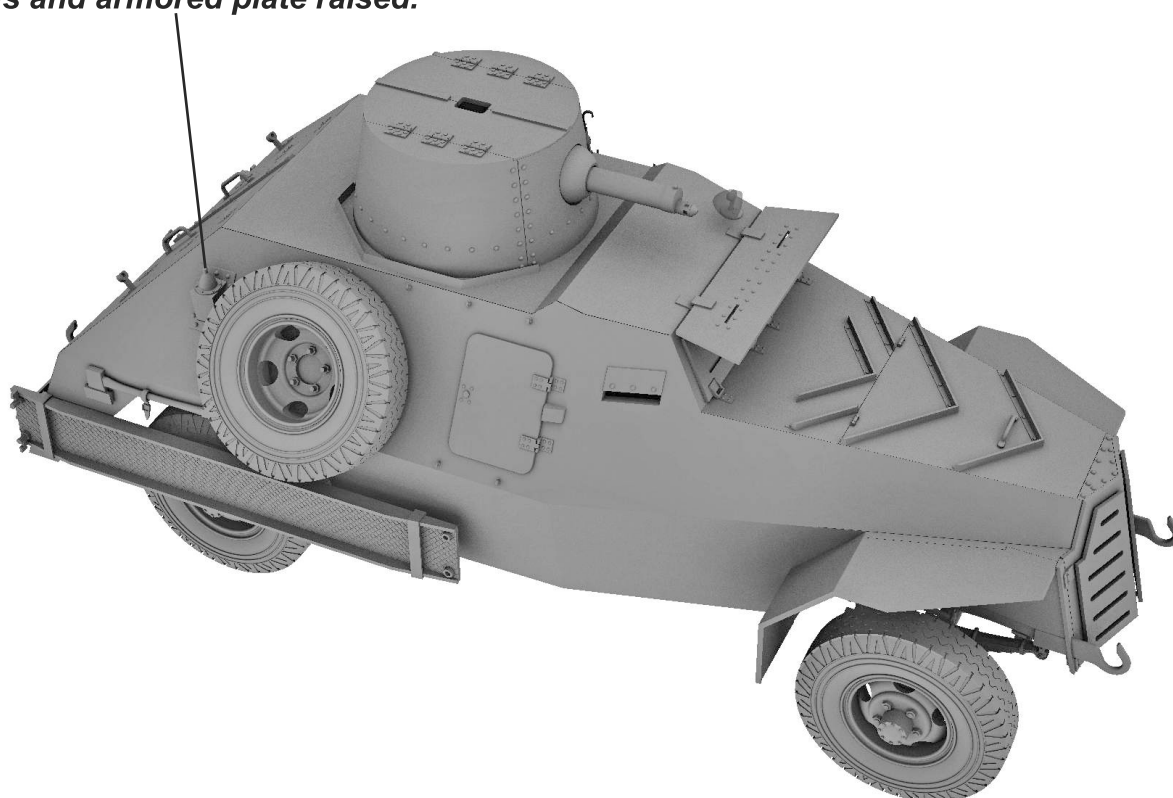

MALOWANIE I KALKOMANIE
COLOURS AND DECALS

Marmon-Herrington Mk II typu MFF o nazwie własnej "Digh Merer"
z niezidentyfikowanej jednostki brytyjskiej
Afryka Północna, lato 1941
*Marmon-Herrington Mk II MFF type called "Digh Merer" from unidentified
british unit
North Africa, summer 1941*

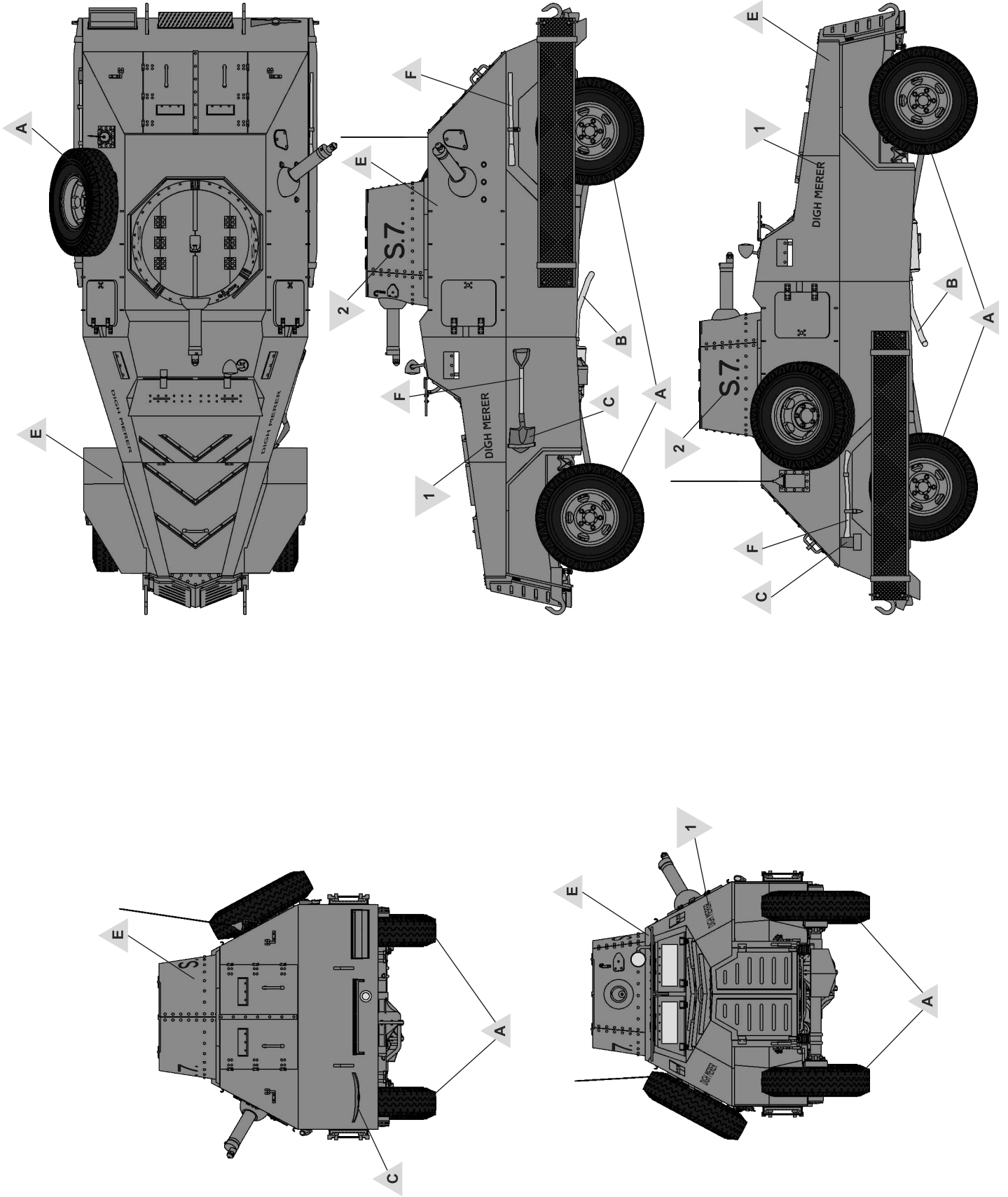

MALOWANIE I KALKOMANIE
COLOURS AND DECALS

Marmon-Herrington Mk II typu MFF z niezidentyfikowanej jednostki brytyjskiej
Afryka Północna, 1941
Marmon-Herrington Mk II MFF type from unidentified british unit
North Africa, 1941

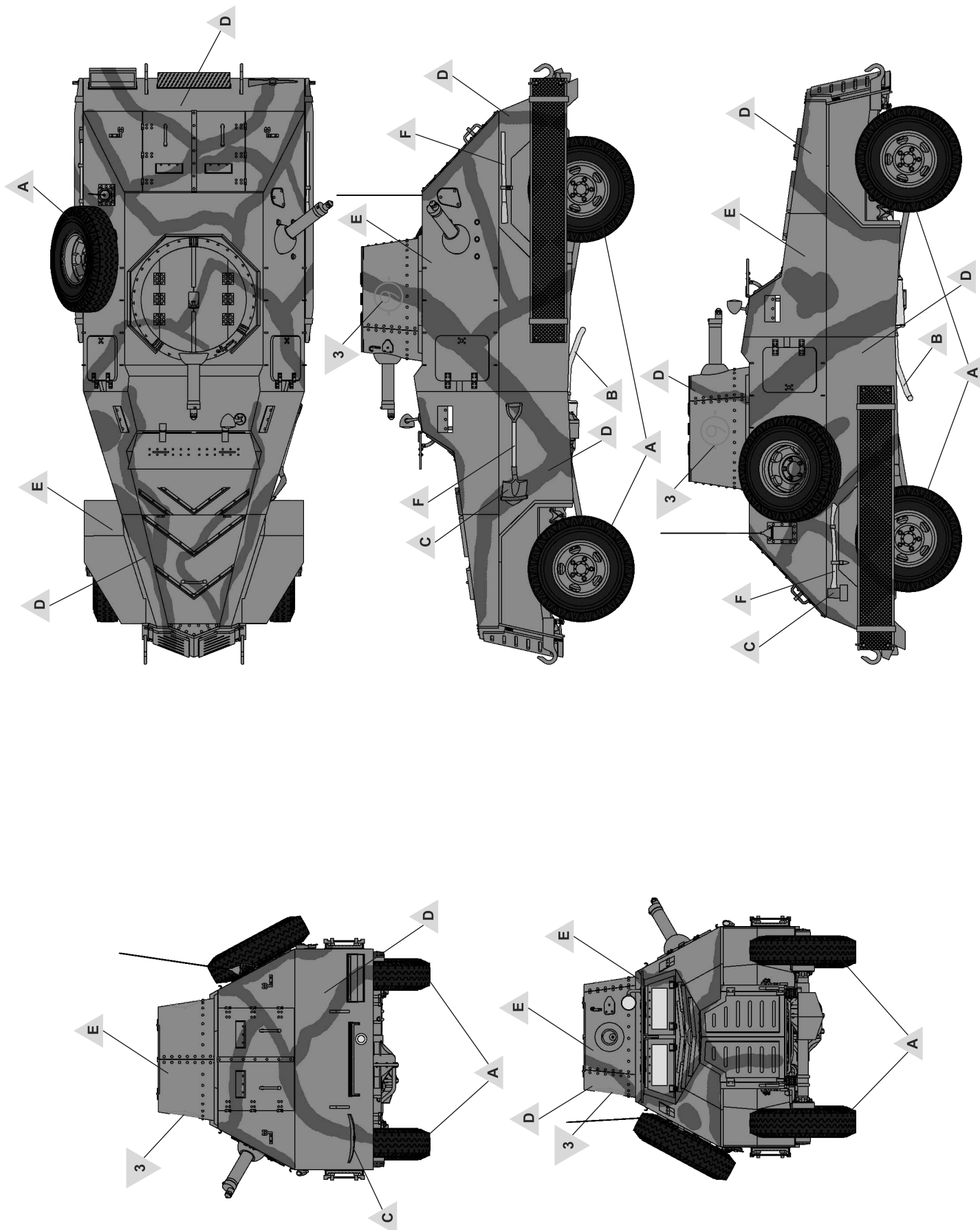

MALOWANIE I KALKOMANIE
COLOURS AND DECALS

Marmon-Herrington Mk II typu MFF z dowództwa niezidentyfikowanego pułku południowoafrykańskiego
Afryka Wschodnia, 1941
*Marmon-Herrington Mk II MFF type from headquarter of unidentified South African regiment
East Africa, 1941*

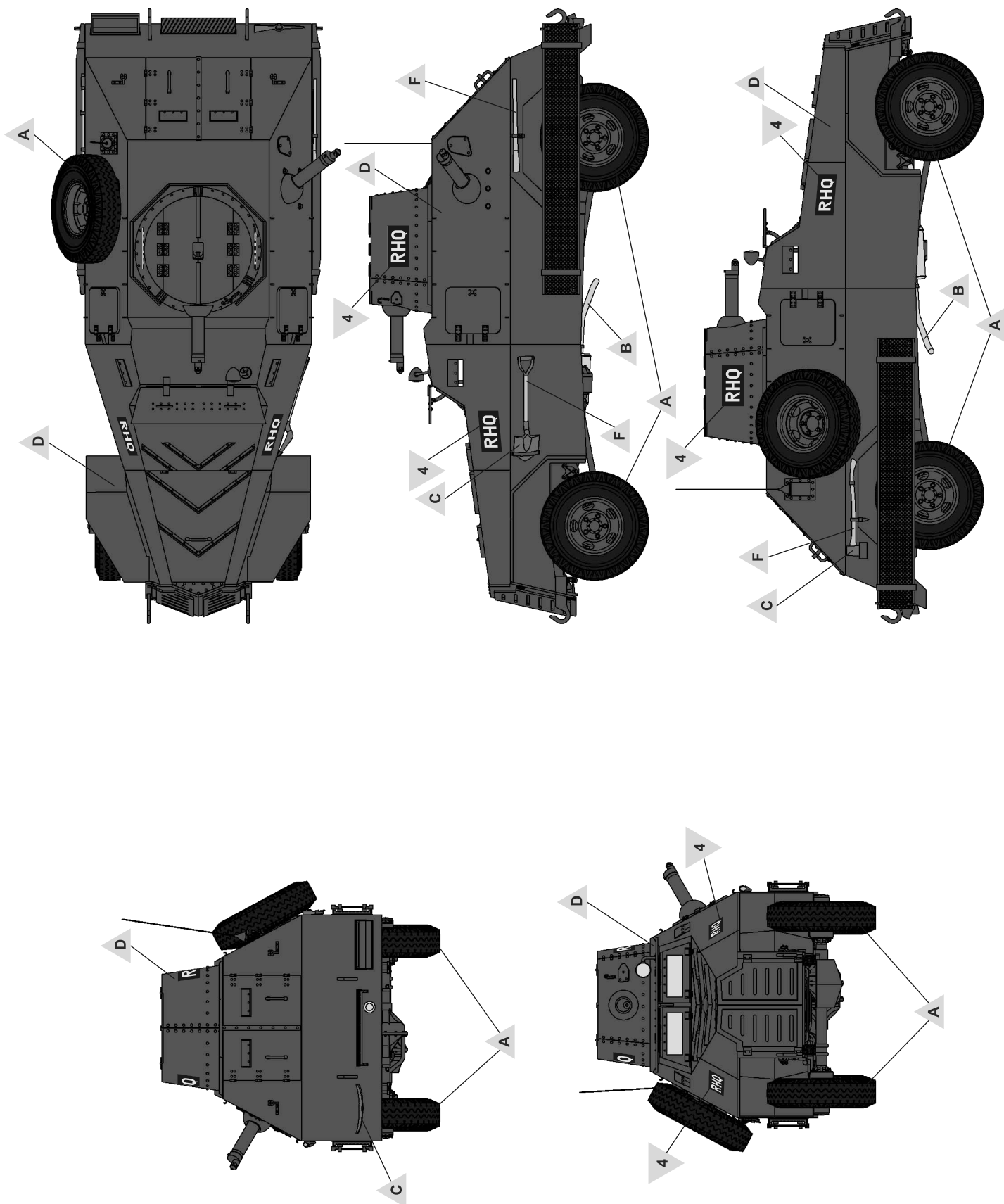

SPECIAL

#1

William Marshall

MARMON HERRINGTON



A History of the South African Reconnaissance Car

Model Centrum PROGRES

229 archival photos • 20 full-color plates
141 color walkaround photos
8 pp 1/35 scale drawings

Gorąco polecamy!!

176 stron, 229 archiwalnych zdjęć, 141 kolorowych zdjęć oryginalnych pojazdów muzealnych, 20 kolorowych planszy barwnych, 8 stron planów skali 1/35, 40 wzorników kolorów. Pytaj w swoim sklepie modelarskim i księgarni lub odwiedź:
www.ibg.com.pl

Strongly recommended!!

176 pages, 229 archival b&w photos, 141 color walkaround photos, 20 full-color plates of artwork, 8 pp 1/35th scale drawings, 7 tables, 2 diagrams, 40 color chips. Ask in Your model shop and bookstore or visit:
www.ibg.com.pl