

**DEUTSCH: ACHTUNG:** Vor dem Zusammensetzen die Bauanleitung gut durchlesen. Jedes Teil ist nummeriert. Reihenfolge der Montageschritte beachten. Benötigte Werkzeuge: Messer und Feile zum Entfernen und Entgraten der Teile, Gummiband, Klebeband und Wäscheklammern zum Zusammenhalten der geklebten Einzelteile. Plastikteile in einer milden Waschmittellösung reinigen und an der Luft trocknen, damit der Farbanstrich und die Abziehbilder besser haften. Vor dem Ankleben prüfen, ob die Teile passen; Klebstoff sparsam auftragen. Chrom und Farbe an den Klebeflächen entfernen. Kleine Teile anstreichen, bevor sie vom Rahmen entfernt werden. Farben gut durchtrocknen lassen, erst dann den Zusammenbau fortsetzen. Jedes Abziehbildmotiv einzeln ausschneiden und ca. 20 Sekunden in warmes Wasser tauchen. Das Motiv an der bezeichneten Stelle vom Papier abschneiden und mit Löschpapier andrücken.

**ENGLISH: ATTENTION:** Carefully read instruction sheet before assembling. Each part is numbered. Consider succession of assembly steps. Required tools: knife and file to remove and trim parts; rubber band, adhesive tape and clothes pegs to hold parts after cementing. Wash plastic in mild detergent solution, rinse and let air dry for better paint and decal adhesion. Scrape chrome and paint at area to be glued; Paint small parts on runner before removing. Allow paint to dry thoroughly before continuing assembly. Cut out each decal one by one and dip it in warm water for approx. 20 sec.; slide decal from the paper at the marked position and dab with blotting-paper.

**FRANCAIS: ATTENTION:** lire soigneusement la fiche d'instructions avant d'assembler. Chaque pièce est numérotée. Suivre la succession des étapes de montage. Outils nécessaires: couteau et lime pour détacher et ébarber les pièces, élastiques, papier adhésif et pinces à linge pour maintenir ensemble les pièces après collage. Laver le plastique dans une solution détergente légère, rincer et laisser sécher à l'air libre pour une meilleure adhérence de la peinture et des décals. Ajuster les pièces ensemble avant de coller. Employer la colle Revell pour plastique exclusivement. Utiliser très peu de colle à chaque fois. Gratter le chrome ou la peinture sur les surfaces à coller. Peindre les petites pièces sur le support avant de les détacher. Laisser la peinture sécher totalement avant de continuer l'assemblage. Découper chaque décal séparément et le plonger dans l'eau chaude environ 20 secondes. Faire glisser le décal du papier à l'endroit du décor et tamponner avec du papier buvard.

**NEDERLANDS: OPGELET:** alvorens te beginnen met het in elkaar zetten, eerst de handleiding goed doorlezen. Elk onderdeel is genummerd. Aandacht besteden aan de volgorde van montage. Het benodigde gereedschap: mesje en vijl voor het verwijderen en het afbramen van de onderdelen, elastiek, plakband en wasknijpers gebruiken voor het bij elkaar houden van de gelijmde onderdelen. De plastic onderdelen met een zacht wasmiddel schoonmaken en laten drogen zodat de verf en de transfers beter hechten. Alvorens te lijmen, eerst vaststellen of de onderdelen

passen; de lijm zuinig opbrengen. Chrom en verf van de op elkaar te lijmen delen verwijderen. Kleine onderdelen verven vóór deze van het gietraam verwijderd worden. De verf goed laten drogen en eerst dan verder gaan met de bouw. Elk transfer apart uitknippen en ca. 20 seconden in lauw/warm water leggen. Het transfer op de juiste plaats van het papier schuiven op het model en met vloepapier andrukken.

**SVENSKA: VIKTIGT:** Läs noggrant igenom instruktionerna innan du börjar bygga. Varje del är numrerad. Tänk igenom ordningsföljden för de olika momenten. Följande verktyg krävs: kniv och fil för att ta loss och putsa detaljerna, gummiband, tejp och klädnyppor för att hålla delarna på plats medan limmet torkar. Tvätta alla plastdetaljerna i mild tvålösning, skölj och låt lufttorka för att få färg och dekalerna att fästa bättre. Proppa alltid detaljerna innan du limmar. Använd endast Revells plastlim. Använd sparsamt med lim. Skrapa bort krom och färg från den yta som ska limmas: måla smådetaljerna innan du skär loss dem. Låt all färg torka ordentligt innan du fortsätter byggandet. Skär ut varje dekal för sig och blöt den i ljummet vatten i ungefär 20 sekunder, och låt dekalen glida av papperet och ner på det markerade läget: sug sedan försiktigt upp det mesta vattnet med löskpapper eller en tygtrasa.

**ITALIANO: Attenzione:** Leggere attentamente le istruzioni prima dell'assemblaggio. Ogni pezzo è numerato. Tener presente la successione delle fasi di assemblaggio. Attrezzi necessari: coltello e lima per rimuovere e rifinire le parti elastiche nastri adesivi e spilli per tenere le parti dopo averle incollate. Lavare la plastica con un detergente delicato, sciacquare e lasciare asciugare all'aria per una migliore adesione della vernice e delle "decal". Accoppiare le parti da incollare. Usare solamente "Revell plastic cement". Usare poco collante. Grattare la cromatura e la vernice nei punti da incollare. Dipingere i piccoli accessori sul supporto prima di rimuoverli. Far seccare bene la vernice prima di continuare nell'assemblaggio. Ritagliare una per una le "decal" ed immergerle in acqua tiepida per circa 20 secondi. Applicare ogni "decal" nella posizione segnata e tamponare con della carta assorbente.

**ESPAÑOL: ATENCIÓN:** cuidadosamente lean la hoja de instrucciones antes del montaje. Cada pieza es numerada, consideren la sucesion de las operaciones de montaje. Herramientas requeridas: cuchilla y lima para quitar y desbarbar las piezas, banda de caucho, cinta adhesiva y pinzas para sujetar las piezas, despues de engomarlas. Lavar el plastico en solucion detergente suave. aclarar y dejar que se seque al aire para una mejor adhesion de la pintura y la calcomania. Adaptar las piezas bien juntas antes de encolar. Solamente utilizar pegamento plastico Revell. Utilizar el pegamento cautelosamente y sin exceso. Raspar el cromado y la pintura en la zona que ha de ser encolada: Pintar las piezas pequeñas giratorias antes de sacarlás. Dejar que la pintura se seque totalmente antes de continuar el montaje. Cortar cada calcomania una por una y sumergirla en agua caliente durante aproximadamente 20 segundos. Deslizar la calcomania del papel en la posición marcada y golpearla suavemente con el papel secante.

Form hergestellt und im Eigentum von Revell AG  
Widerrechtliche Nachahmungen werden gerichtlich verfolgt.

Mould produced by and the property of Revell AG  
Unlawful imitations will be subject to prosecution.

Forme produite par et propriété de Revell AG  
Les contrefaçons seront poursuivies par voies légales.

Vorm vervaardigd door en eigendom van Revell AG  
Onrechtmatige nabootsingen worden gerechtelijk vervolgd.



Kleben  
Glue  
A coller  
Lijmen  
Limmas  
Incollare  
Engomrar



Nicht kleben.  
Don't glue.  
À ne pas coller.  
Niet lijmen.  
Timmas ej.  
Non incollare.  
No engomrar.



Anzahl der Arbeitsgänge.  
Number of working steps.  
Nombre d'étapes de travail  
Het aantal der bouwhandelingen.  
Antal arbetsmoment.  
Numero di passaggi.  
Numero de operaciones de trabajo.



Wahlweise  
Optional  
Facultatif  
Ter keuze  
Valfritt  
Facoltativo  
Opcional

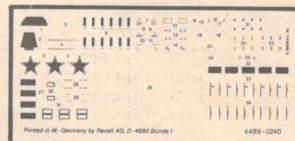

Abziehbild in Wasser einweichen und anbringen.  
Soak and apply decals.  
Mouiller et appliquer les décals.  
Transfer in water even laten weken en opbrengen.  
Blöt och fäst dekalerna.  
Immergere in acqua ed applicare decal.  
Remojir y aplicar las calcomanias.



Abbildung zusammengebaute Teile.  
Shown assembled.  
Vu assemblé.  
Afbeelding van een gebouw onderdeel.  
Visas hopsatt.  
Figura assemblata.  
Presentado montado.

18

Klarsichtteile  
Clear parts  
Pièces transparentes  
Transparante onderdelen  
Genomskintliga detaljer  
Parte trasparente  
Limpiar las piezas

A

ANTHRACITE  
**ANTHRAZIT 9**  
ANTHRACIET  
ANTHRACIET  
ANTRACIT  
ANTRACITE

B

ALUMINIUM  
**ALUMINIUM 99**  
ALUMINIUM  
ALUMINIUM  
ALUMINIUM  
ALUMINIUM

C

GREY  
**GRAU 57**  
GRIS  
GRIS  
GRA  
GRIGIO

D

GRANIT GREY  
**GRANITGRAU 69**  
GRIS GRANITE  
GRANITGRIS  
GRANITGRA  
GRIGIO GRANITO

E

MATT YELLOW  
**MATT GELB 15**  
JAUNE MAT  
MAT GEEL  
MATT GUL  
GIALLO SMORTO

F

BEIGE  
**BEIGE 314**  
BEIGE  
BEIGE  
BEIGE  
BEIGE

G

RUSH GREEN  
**SCHILFGRÜN 382**  
VERT JONC  
RIETGRÖEN  
VASSGRÖEN  
VERDE CHIARO

H

DARK GREEN  
**DUNKELGRÜN 363**  
VERT FONCE  
DONKERGRÖEN  
MÖRK GRÖN  
VERDE SCURO

I

BROWN  
**BRAUN 381**  
BRUN  
BRUN  
BRUN  
MARRONE

J

FIERY RED  
**FEUERROT 330**  
ROUGE VERMILLON  
VUURROOD  
ELDROOD  
ROSSO ACCESO

K

BLACK  
**SCHWARZ 302**  
NOIR  
ZWART  
ZWART  
NERO

L

MATT LIGHT BLUE  
**MATT HELLBLAU 55**  
BLEU CLAIR MAT  
MAT VAALBLAUW  
MATT LJUSTBLÅ  
AZZURRO SMORTO

M

BASALT GREY  
**BASALTGRAU 77**  
GRIS BASALTE  
BASALTGRIS  
BASALTGRÅ  
GRIGIO BASALTO

Sollte es einmal vorkommen, daß ein Teil im Bausatz fehlt, bitte an REVELL AG, Postfach 2609 + 2620, Abteilung X, 4980 Bünde, schreiben und die Bauanleitung, auf der das fehlende Teil angekreuzt ist, mitschicken, sonst können wir keinen Ersatz leisten.

Should you find any missing parts, please write to REVELL AG, 2609 + 2620, department X, D-4980 Bünde, W. Germany, and we will send you these as quickly as possible with our compliments. Please indicate clearly with a cross on the instruction leaflet, which piece(s) are missing. Always remember to write your name and address clearly and in full.

Zou het voorkomen, dat er een deel in de bouwdoos ontbreekt, kunt U schrijven naar REVELL AG, Postbus 2609 + 2620, Afdeling X, D-4980 Bünde. De bouwbeschrijving waarop het ontbrekende deel aangekruist is, bijsluiten, anders kunnen wij U dit onderdeel niet vergoeden. Vergeet vooral niet Uw naam en adres duidelijk te vermelden.

Pour toute pièce manquante, écrivez à REVELL AG, Postbus 2609 + 2620, département X, D-4980 Bünde, et cet élément vous sera aussitôt envoyé et ce, gratuitement. Il vous suffit dans ce cas de marquer d'une croix la pièce manquante sur la feuille d'instruction du modèle choisi. N'oubliez surtout pas d'écrire clairement votre nom et adresse.



1 

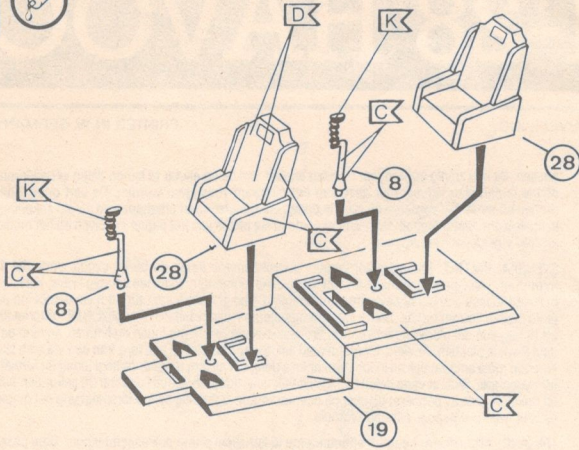

2 

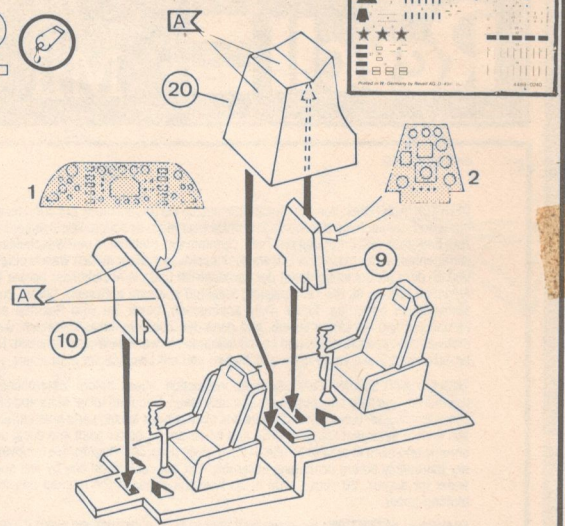

3 

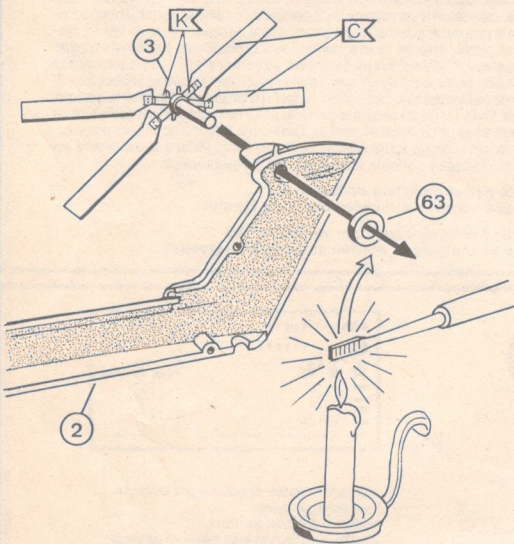

4 

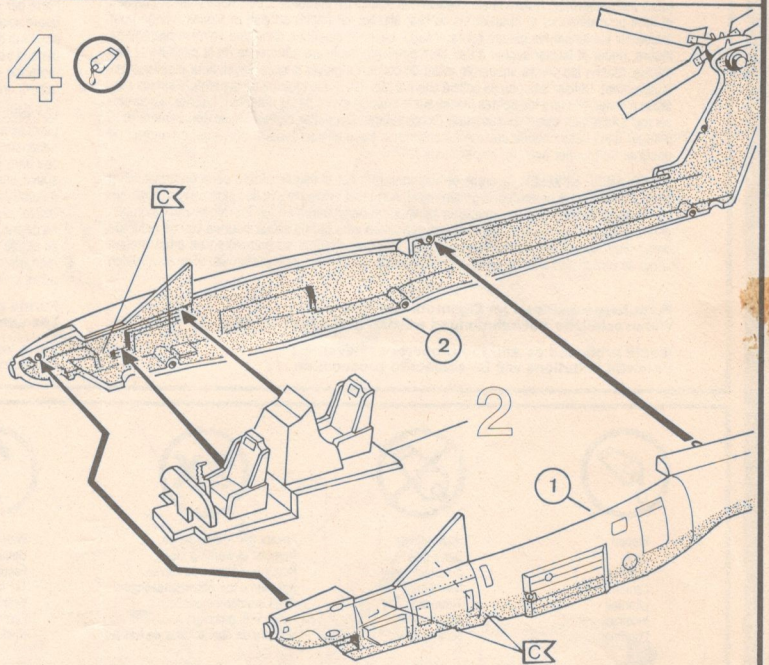

5 

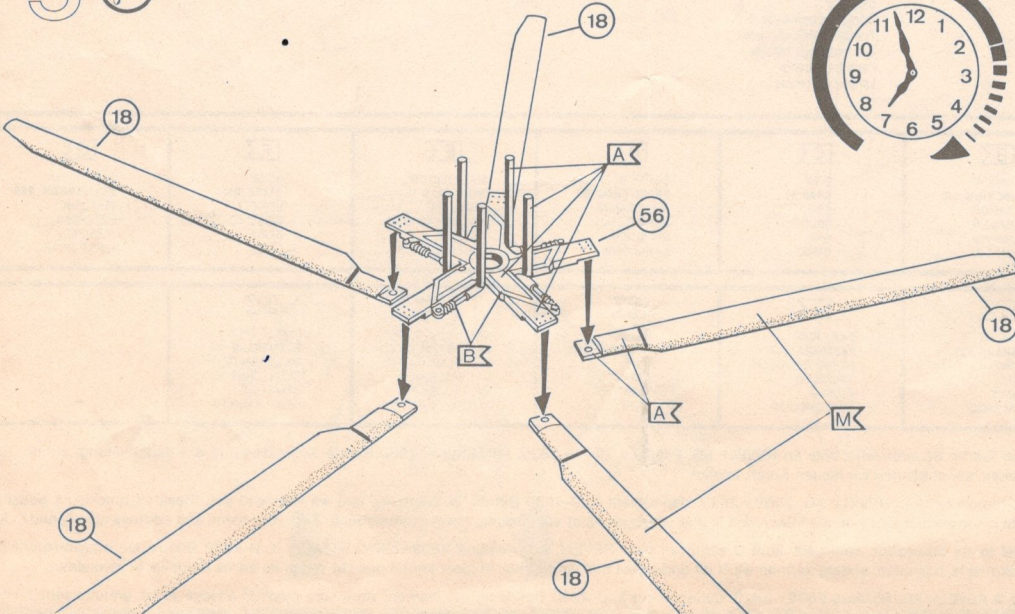

Den Klebstoff längere Zeit in Ruhestellung abbinden lassen (mindestens 1 Stunde)

Let the glue set for an extended period without moving the part (at least 1 hour)

Laisser prendre la colle au repos pendant un temps assez long (au-moins 1 heure)

De lijm geruime tijd in rust af laten binden (minstens 1 uur)

Deje el adhesivo en reposo por un tiempo prolongado para que se seque bien (1 hora como mínimo)

Limmet kräver en längre bindningstid i viloläge (minst 1 timme)

Lasciare far presa il collante in posizione di riposo per un tempo piuttosto lungo (almeno 1 ora)



6

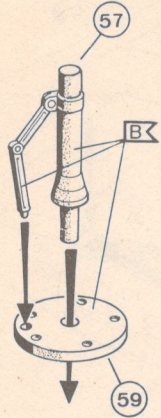

7

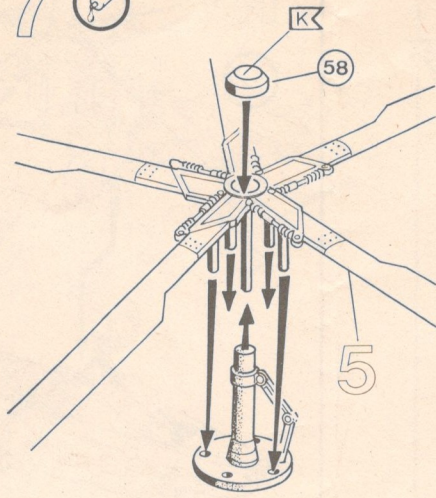

8

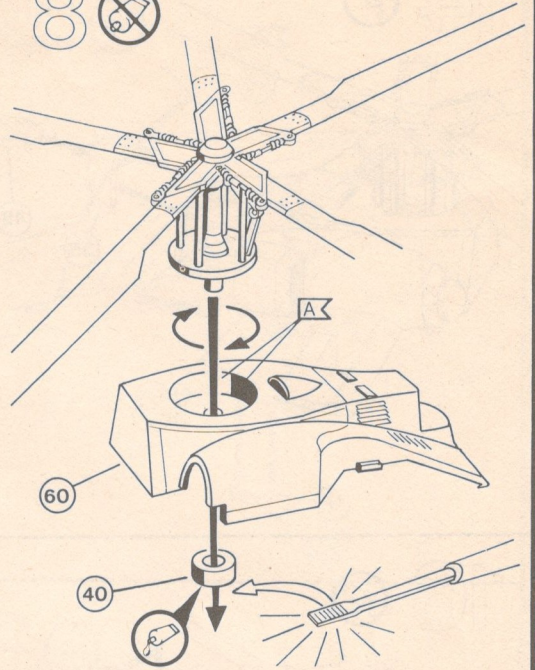

9

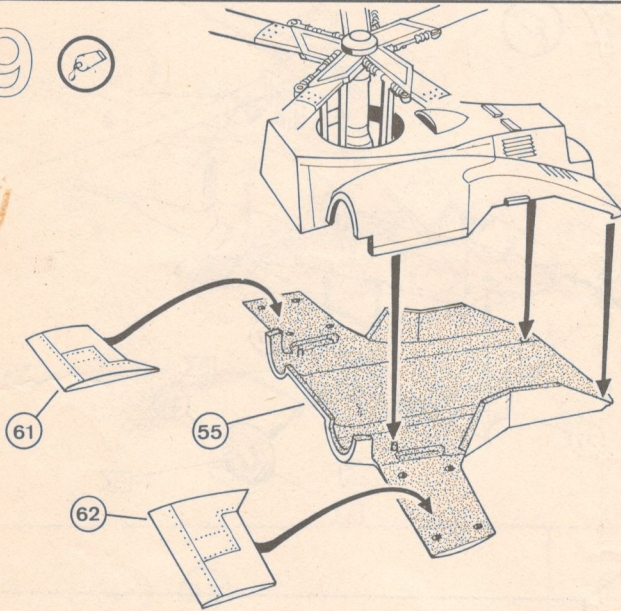

10

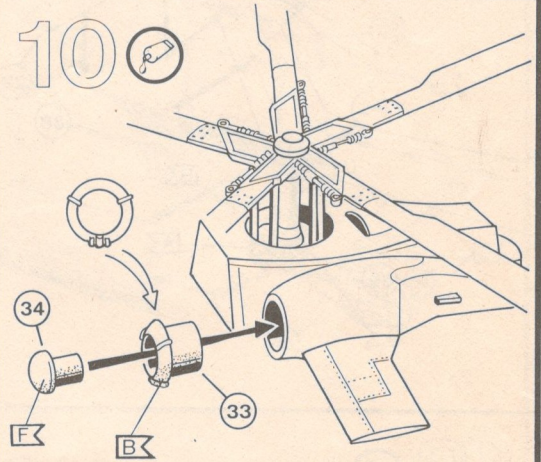

11

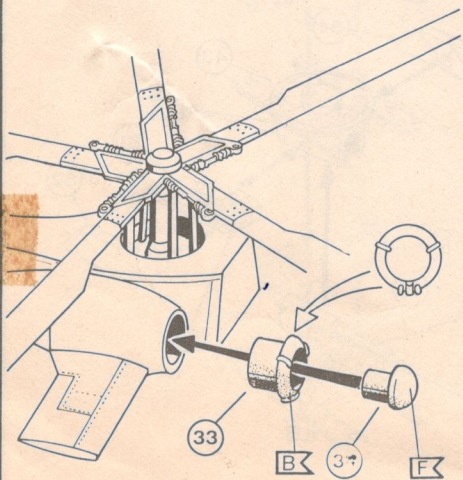

12

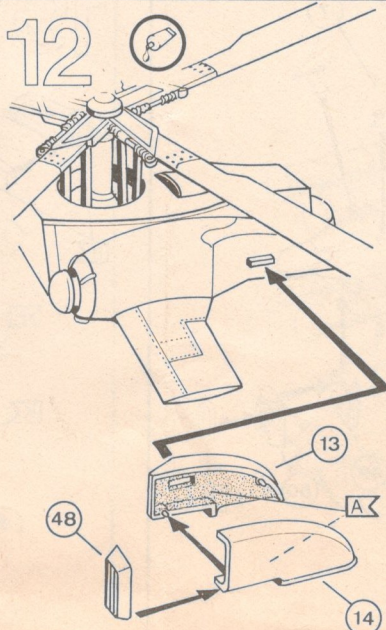

13

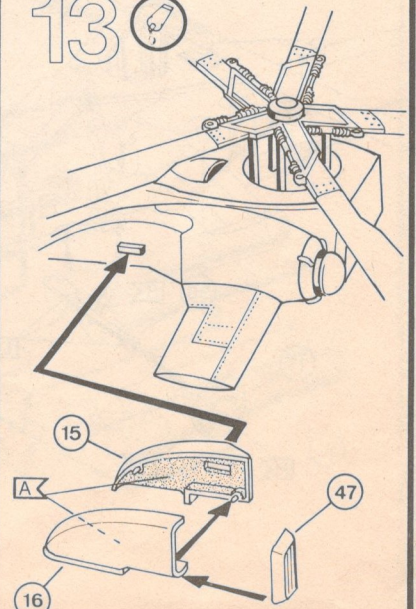



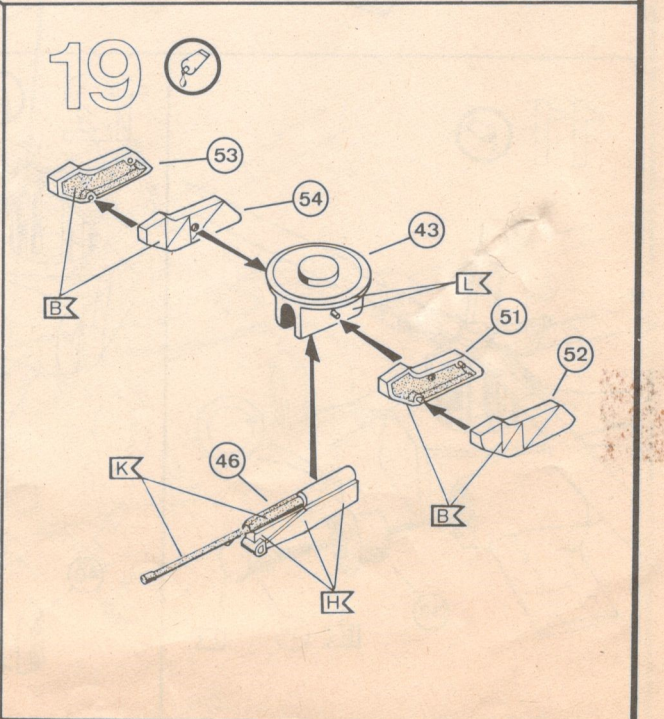
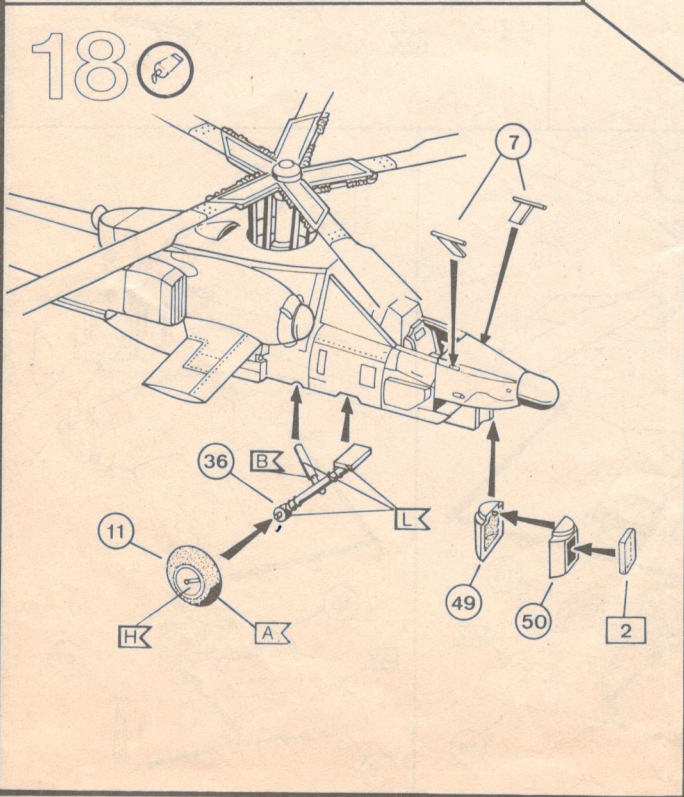
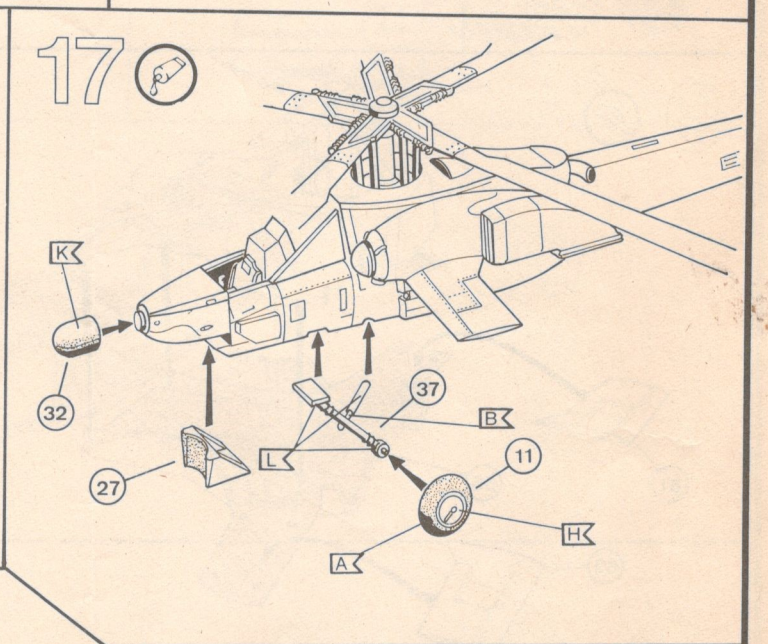
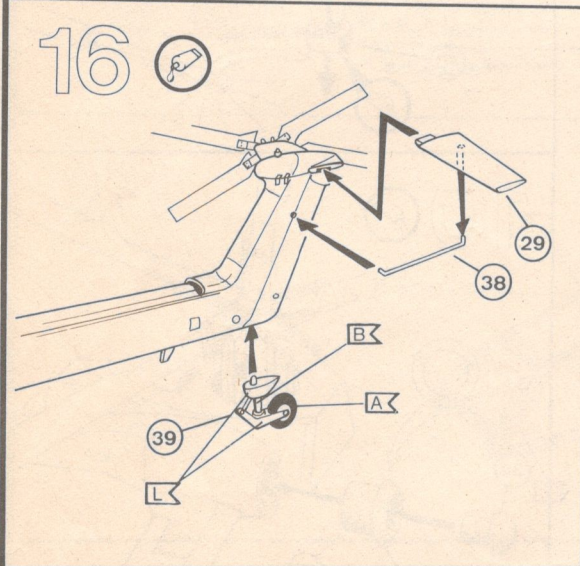
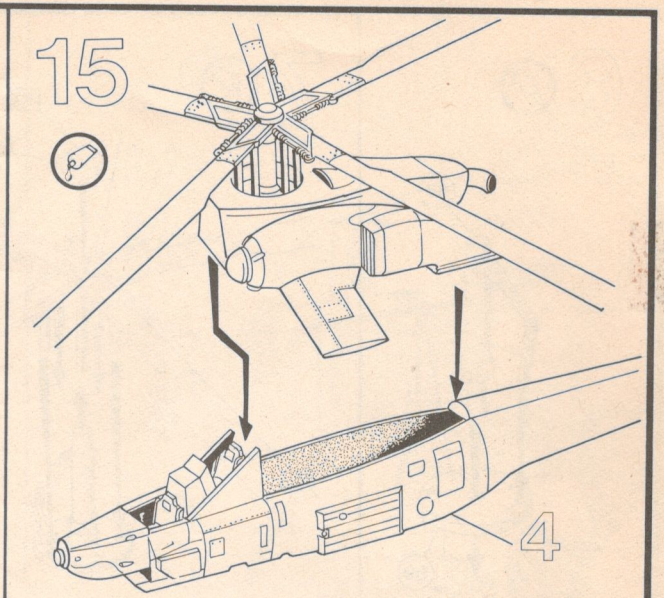
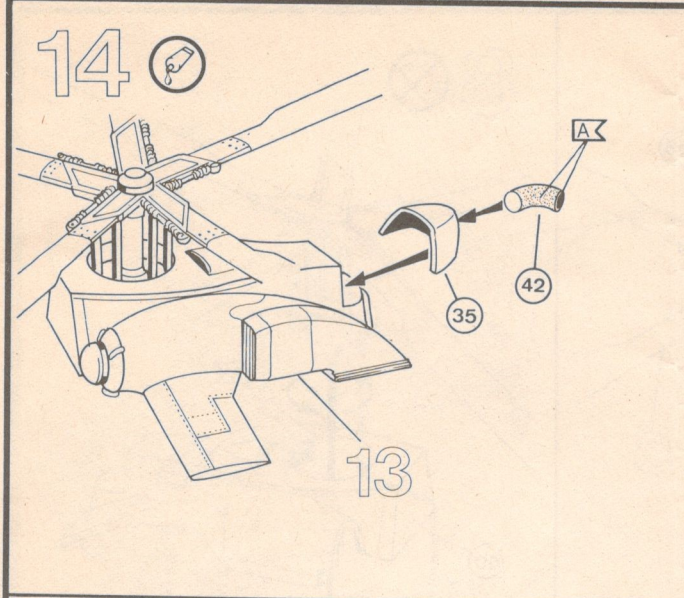





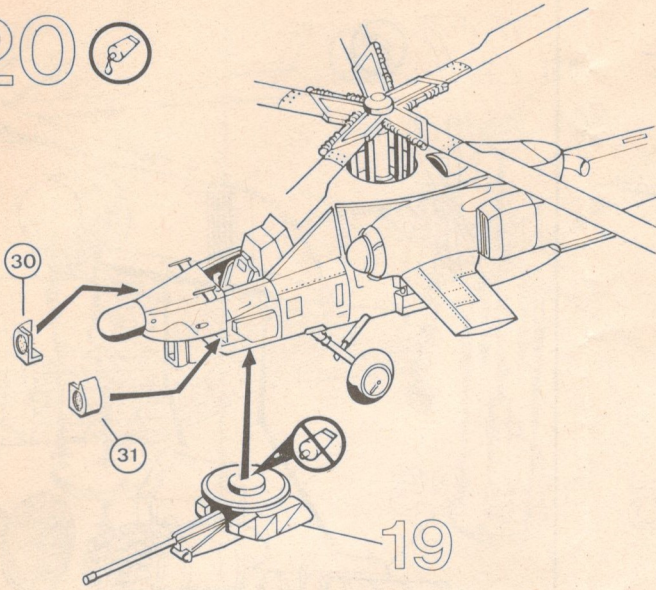

20 

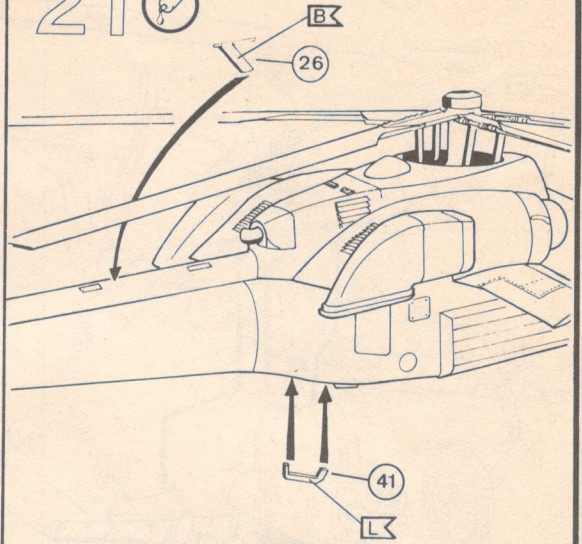

21 



22 

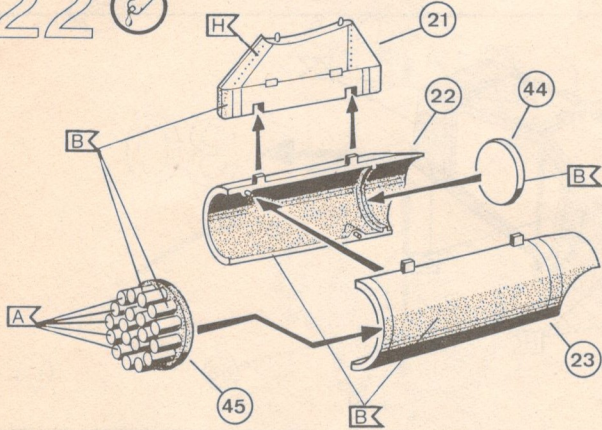

23 

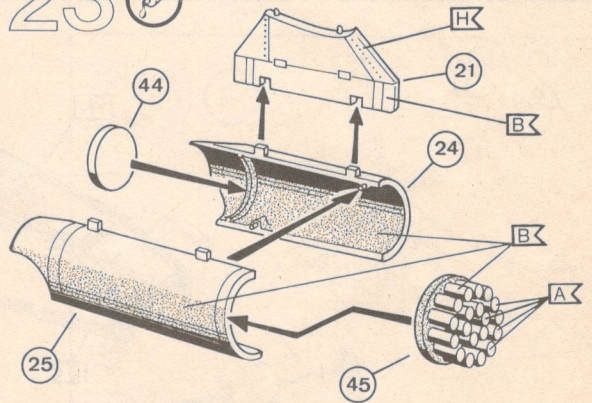

24  **2X**

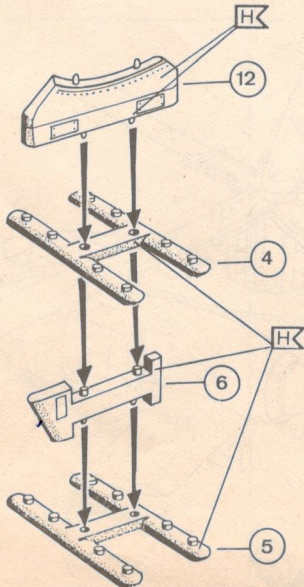

25  **2X**

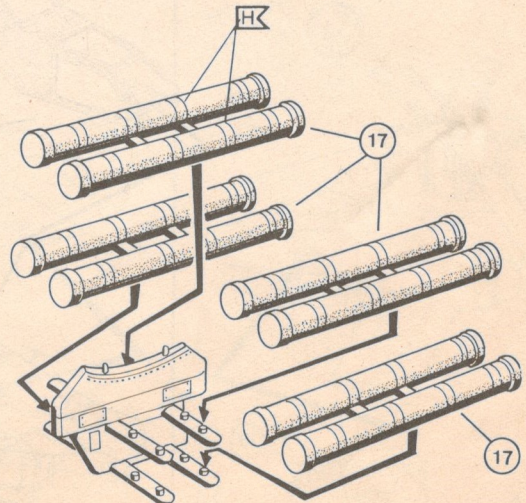



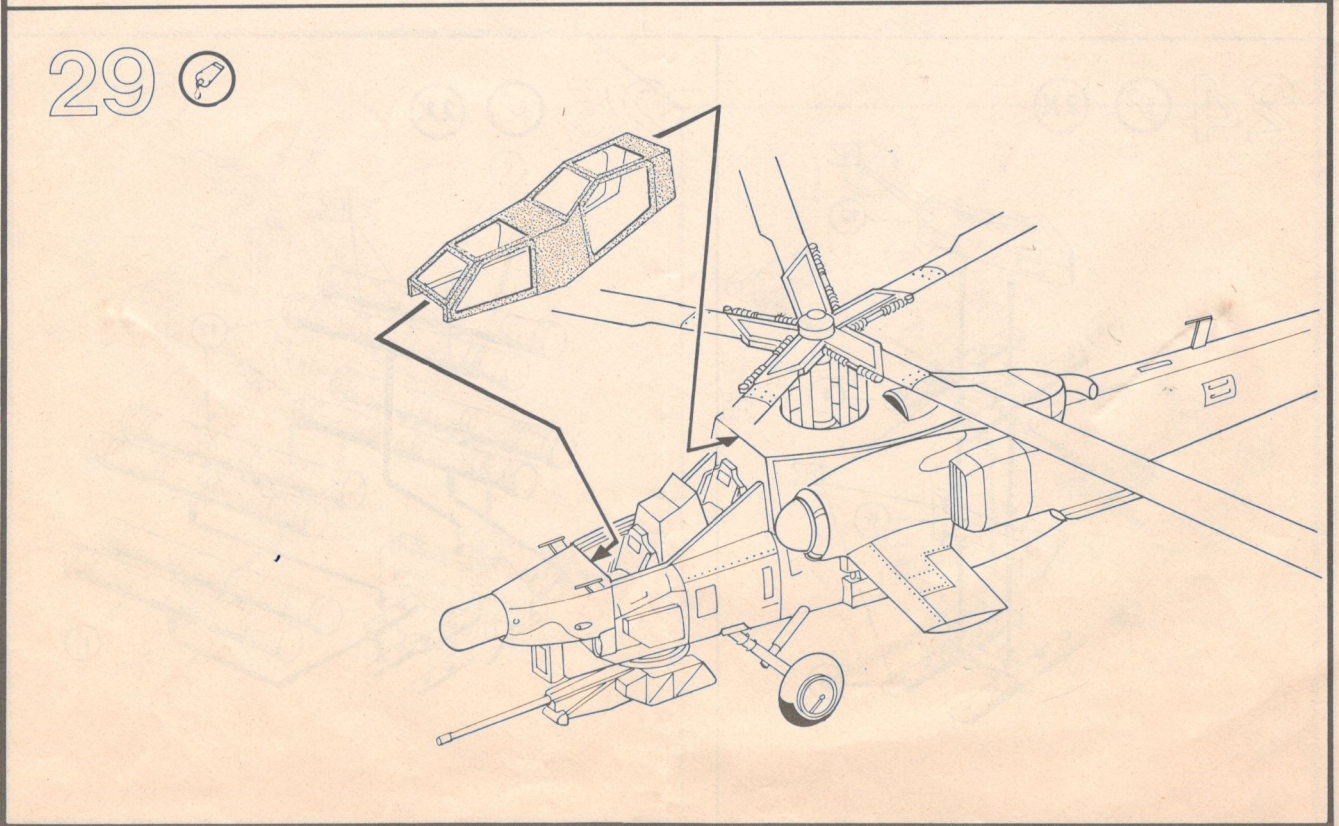
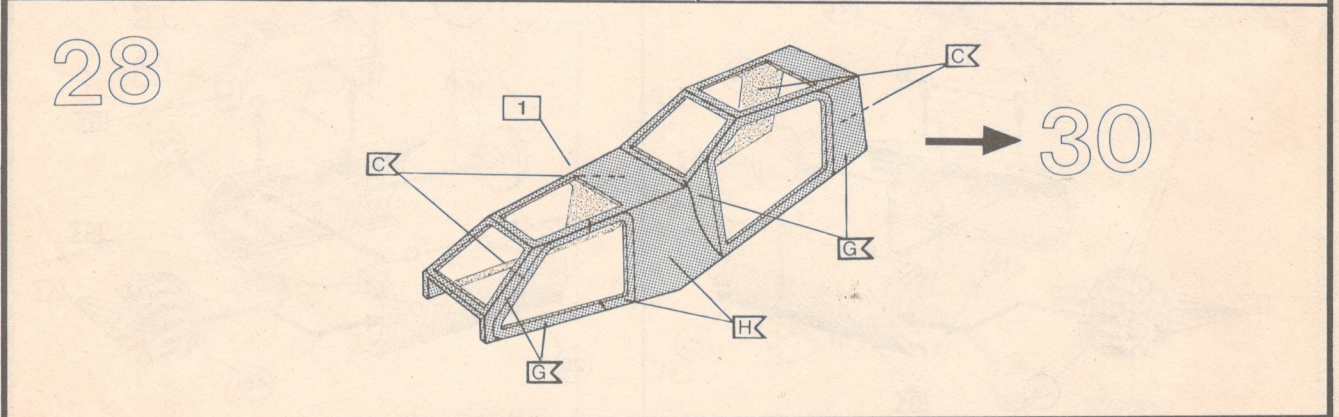
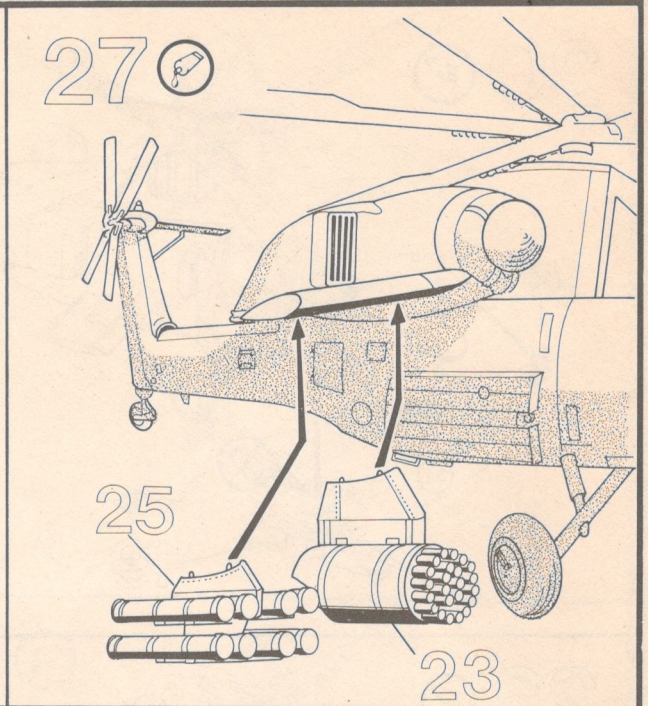
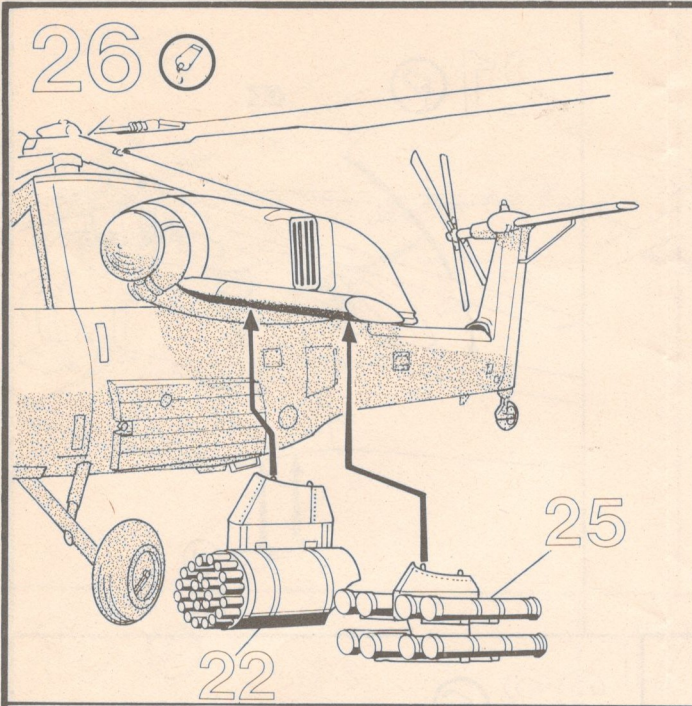



30

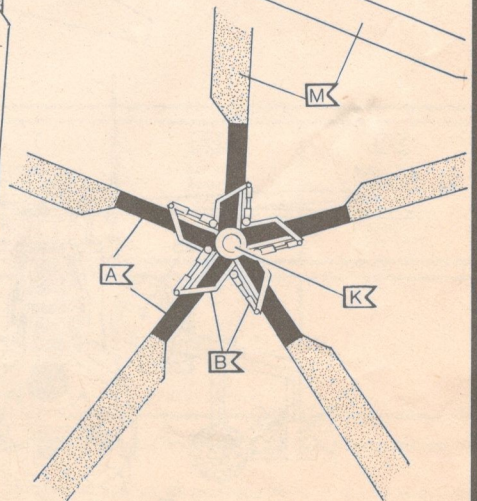
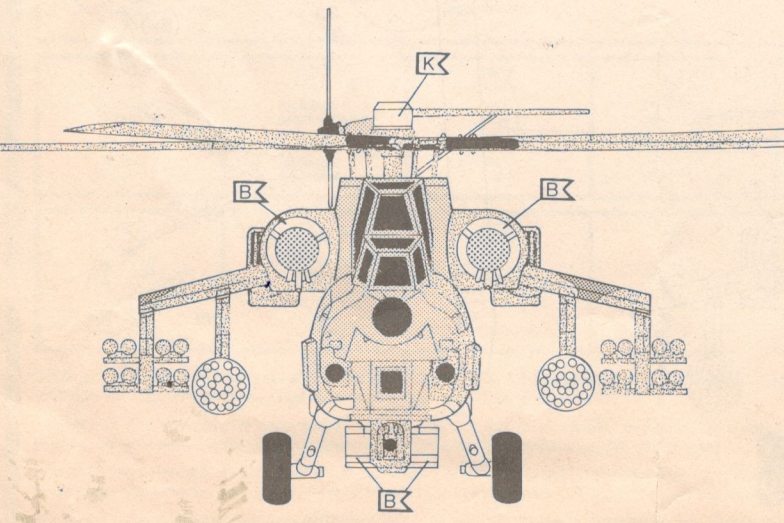
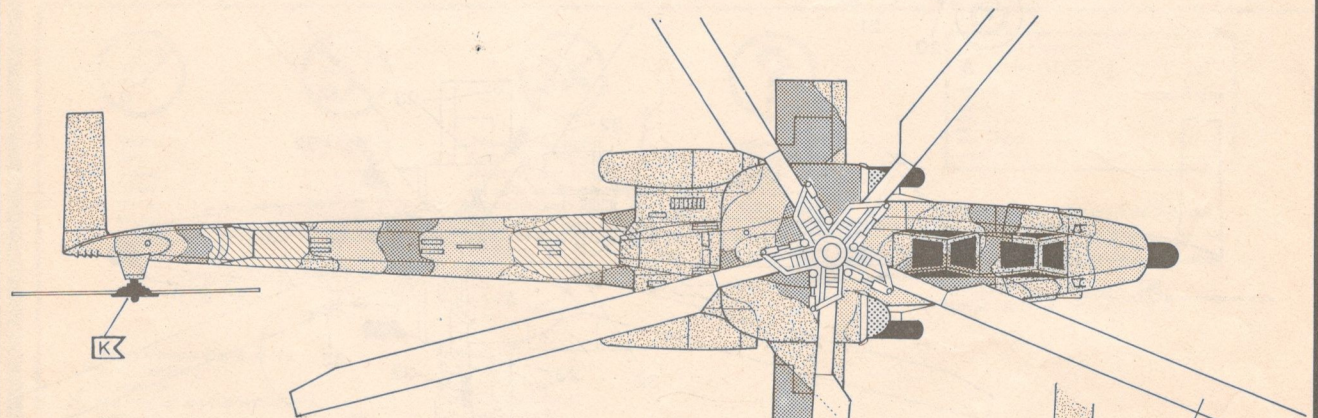
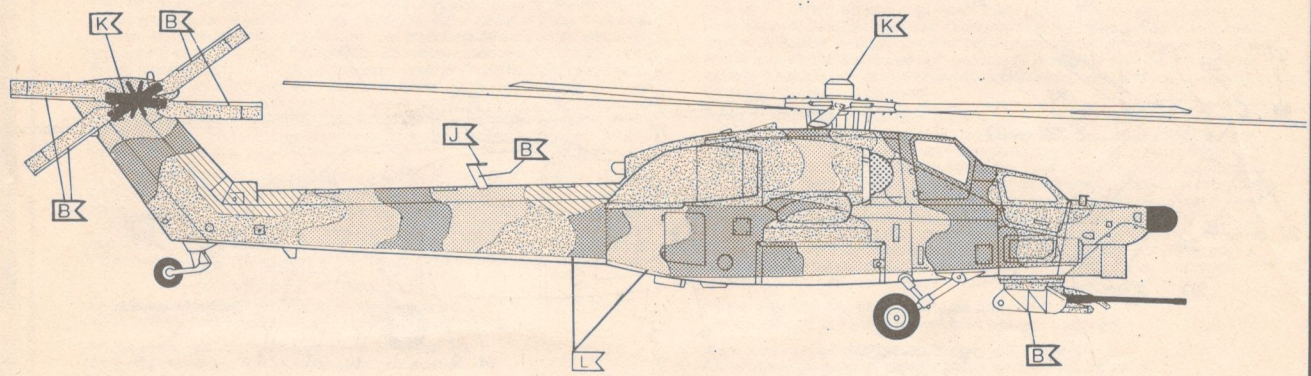
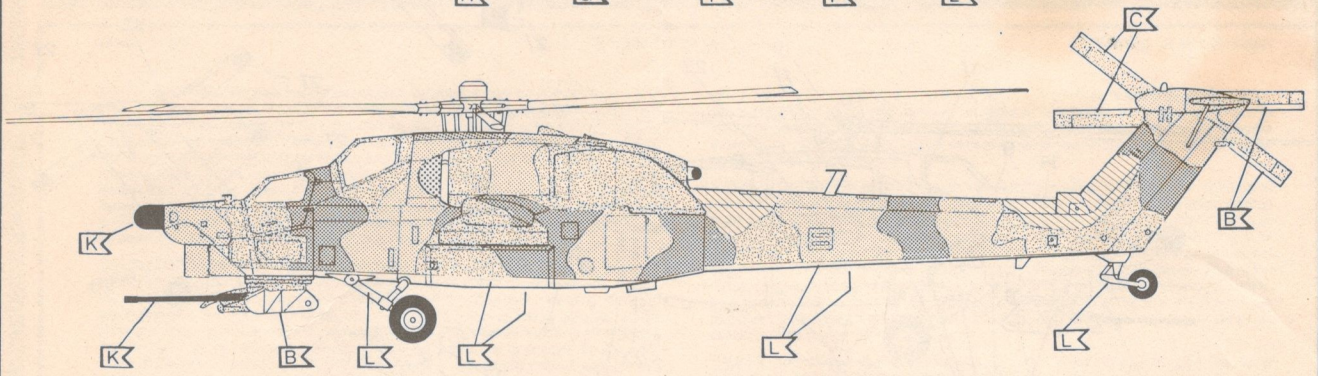



# 30

