

# Curtiss P-40K-10/15 Warhawk III long tail

SW 72065 scale: 1/72



Curtiss P-40 was the last in line of Curtiss Hawk fighters. The prototype XP-40 was based on already proved airframe used in Hawk 75.

On October 28, 1941, 600 P-40Ks were ordered for Lend-Lease supply to China. It was thought that this would be the last P-40 model to be built in quantity, replaced by P-60.

However, delays in the P-60 program caused the order for P-40Ks to be increased to a total of 1300 aircraft on June 15, 1942.

The P-40K-1-CU and P-40K-5-CU were generally similar to late-production P-40Es except for the Allison engine.

The K-1 and K-5 retained the short fuselage of the P-40E, but were equipped with dorsal fin to minimize tendency to swing during take-off due to more powerful Allison engine.

The P-40K-10s and later production blocks had the longer fuselage that was introduced on the P-40F-5-CU. The P-40K-15-CU was winterized.

The maximum speed of the P-40K was 320 mph at 5000 feet and 362 mph at 15,000 feet. A climb to 15,000 feet took 7.5 minutes. Range was 350 miles with a 500-pound bomb attached.

Most of the P-40Ks served with the US forces in Asia and the Pacific and under Lend-Lease with the Chinese Air Force.

192 P-40K-1-CUs were diverted to England under Lend-Lease as Kittyhawk III. RAF serials were FL875/FL905, FR111/FR115, FR210/FR361, and FL710/FL713.

The first examples were delivered to the Middle East in late 1942.

RAAF used 42 P-40Ks under serials A29-164/202 (P-40K-10-CU) and A29--203/205 (P-40K-15-CU).

P-40s also flew with RCAF, RNZAF and in Brazil.

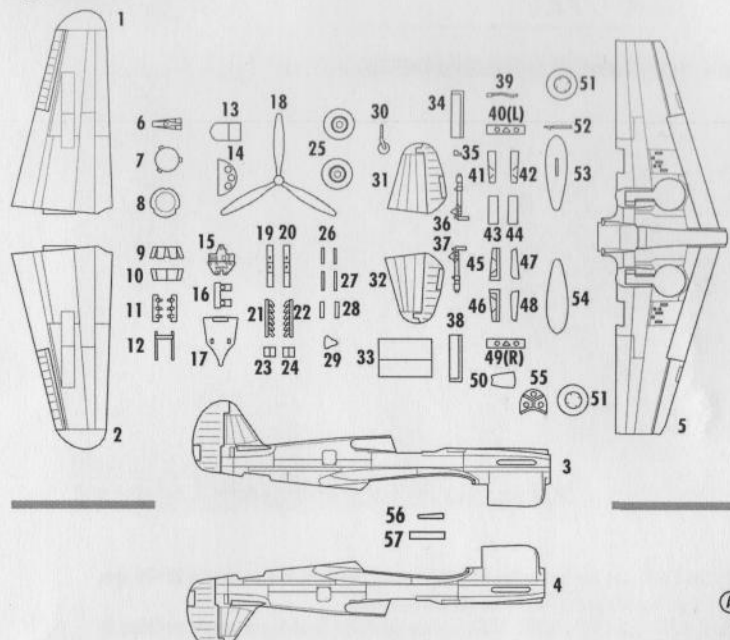

CLEAR		BARVA/COLOR
CP1	CP3	A Černá/Black
CP2	CP4	B Světle šedá Light Grey
CP5		C Stříbrná/Silver
		D Hliník/Aluminium
		E Šedá/Grey
		F Červená/Red
		G Žlutá/Yellow
		H Zelená/Green
		I Černošedá/ Tyre Black
		J Špinavý hliník/ Dirty Aluminium
		K Chromová/ Chrome
		L Hnědá/Brown
		M Kovová/Gun metal
		N Růžová/Rust

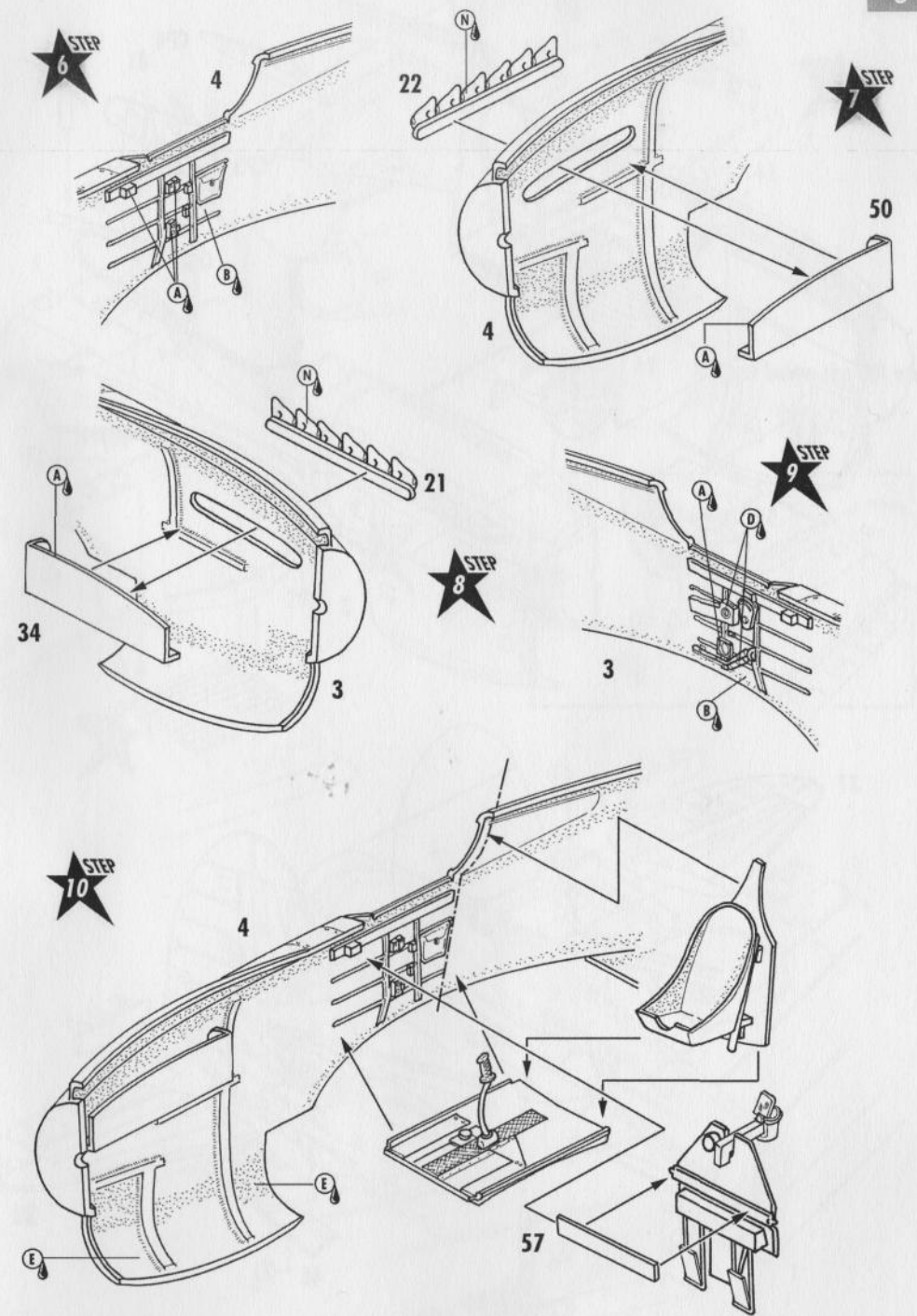
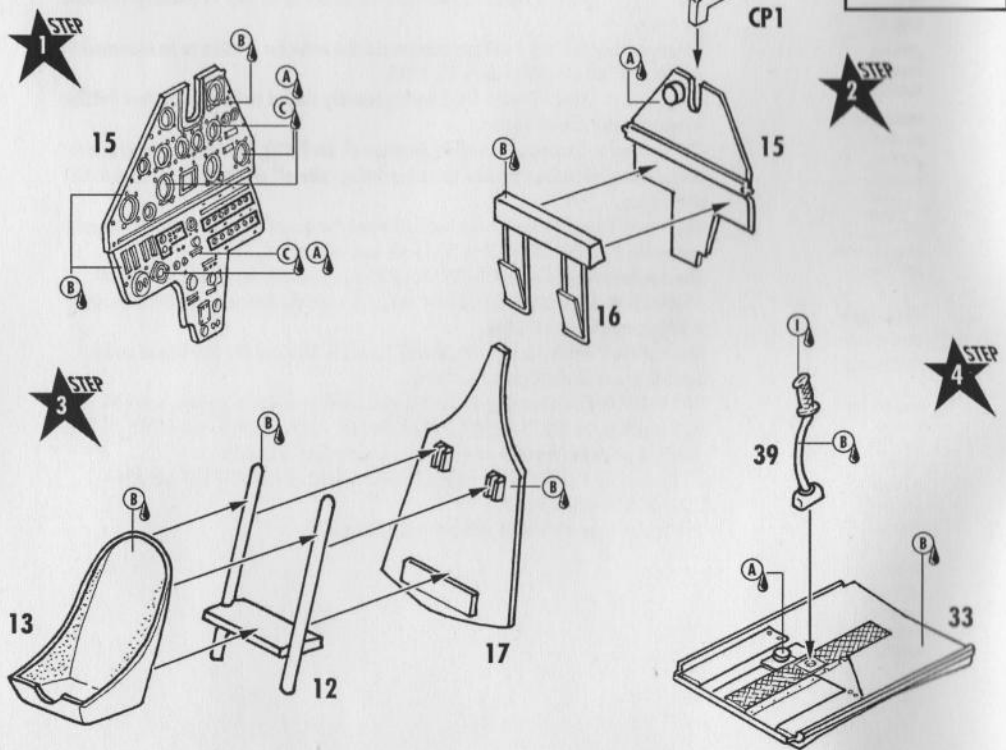

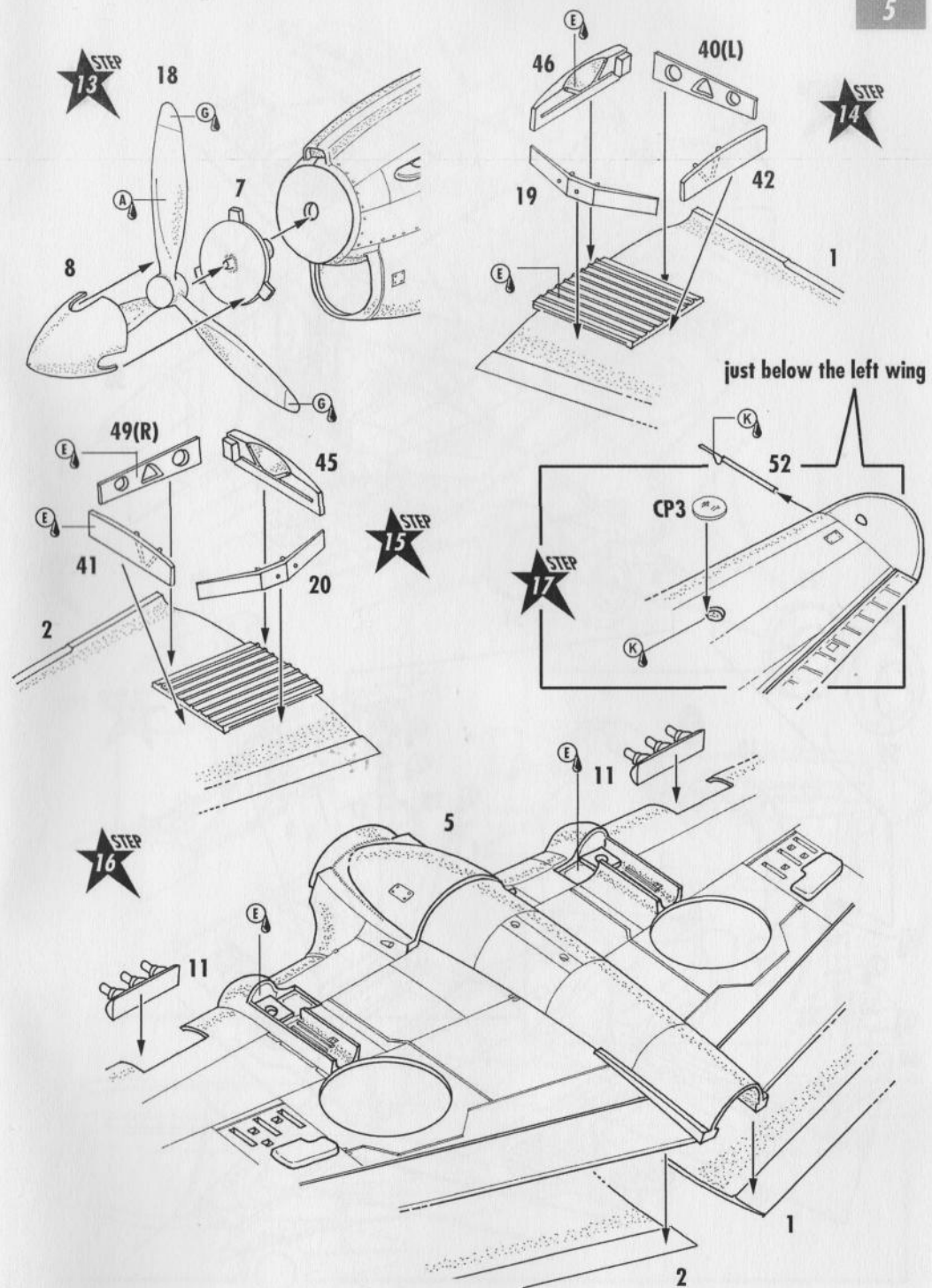
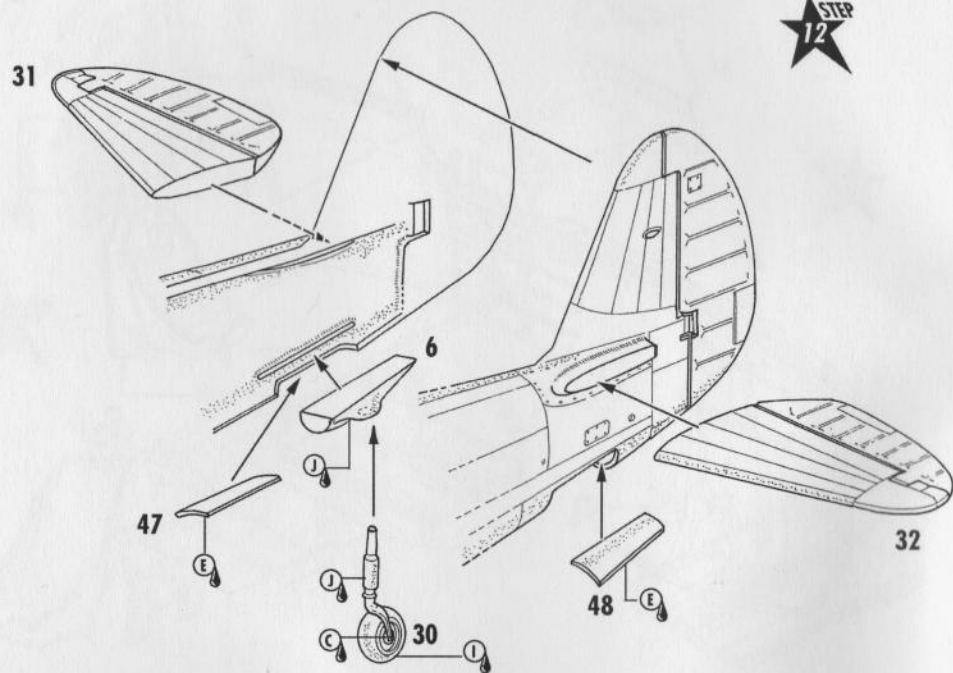
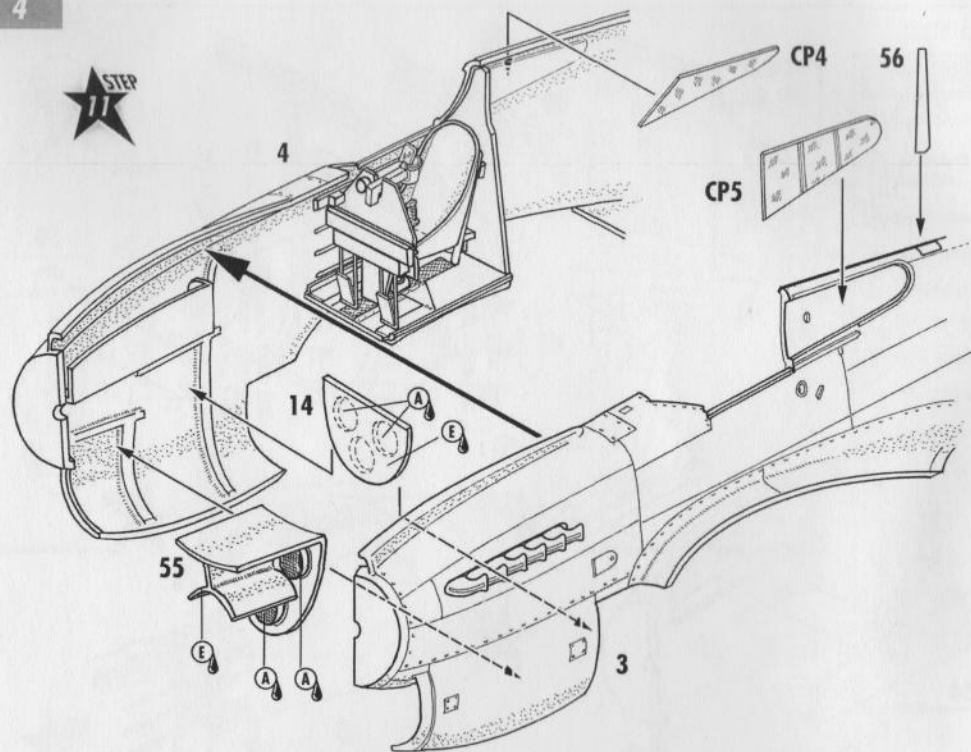

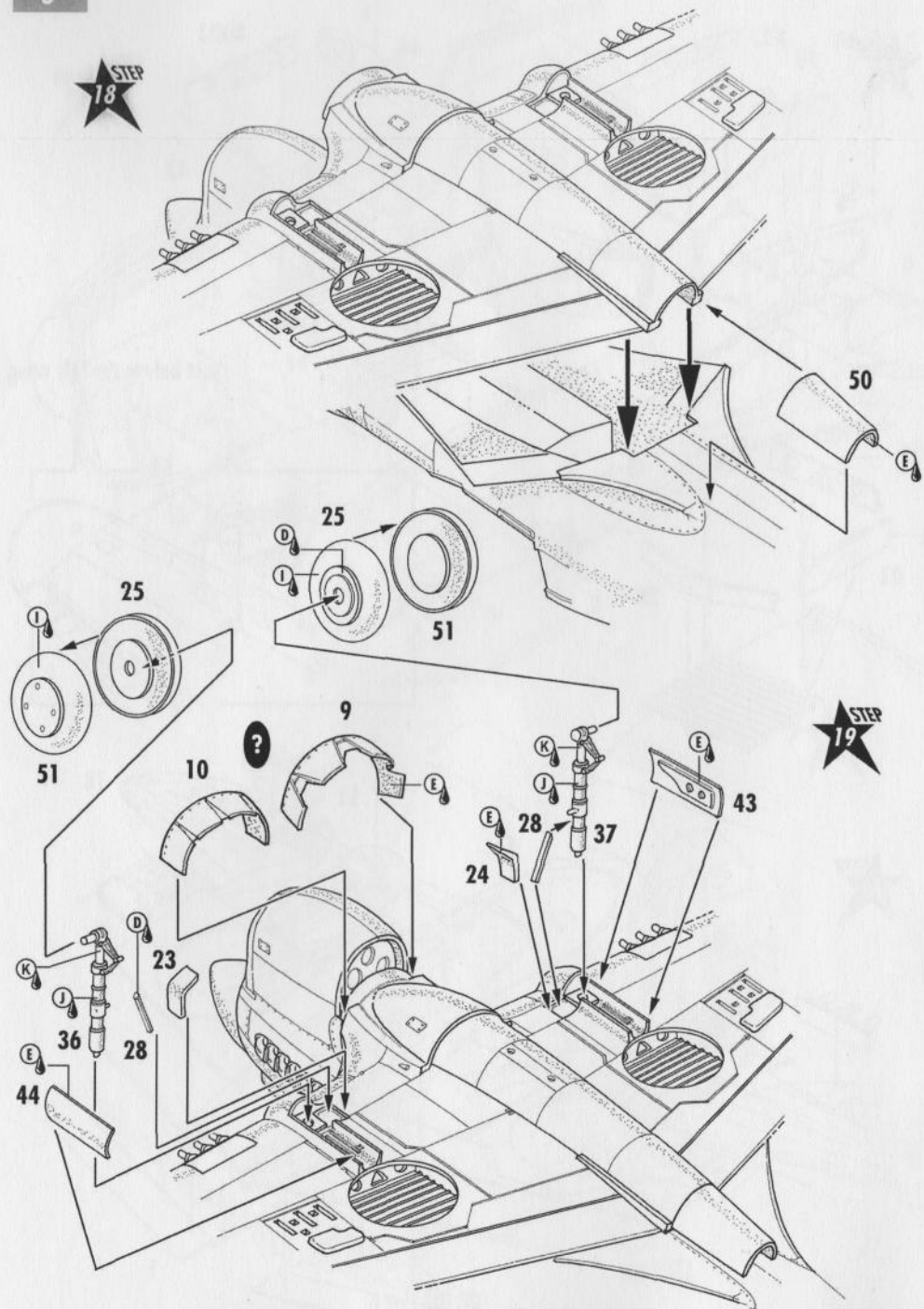
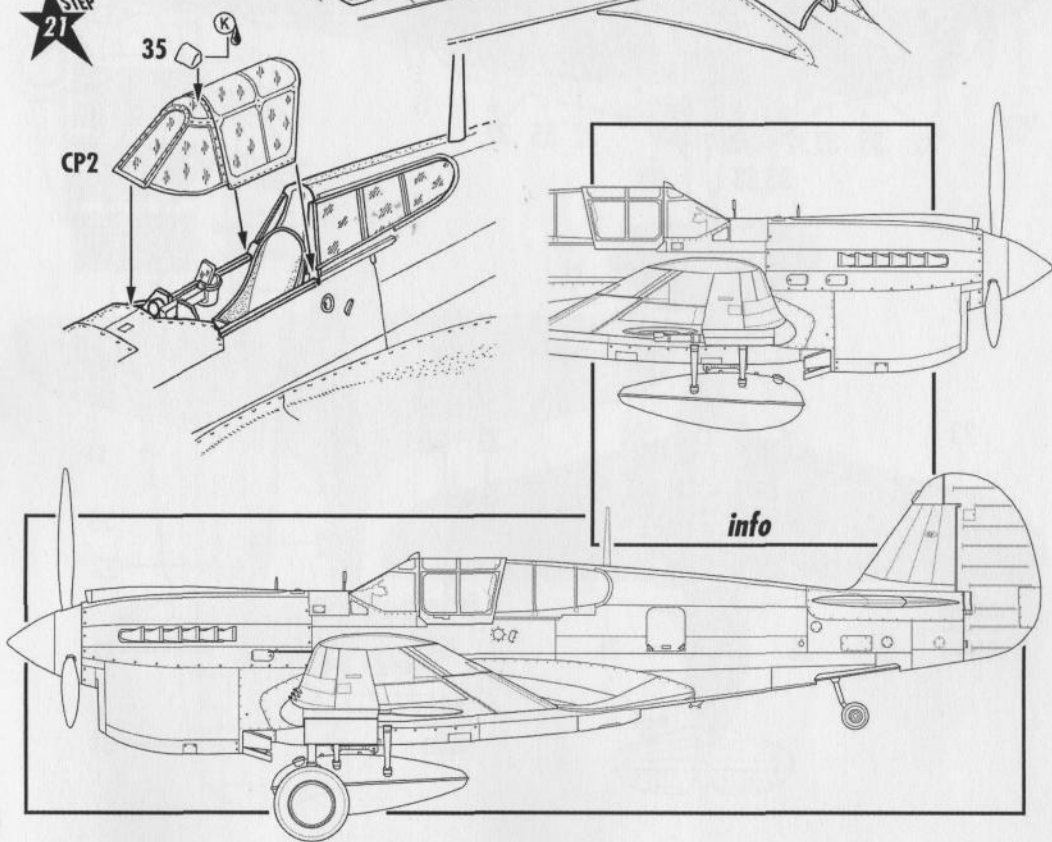
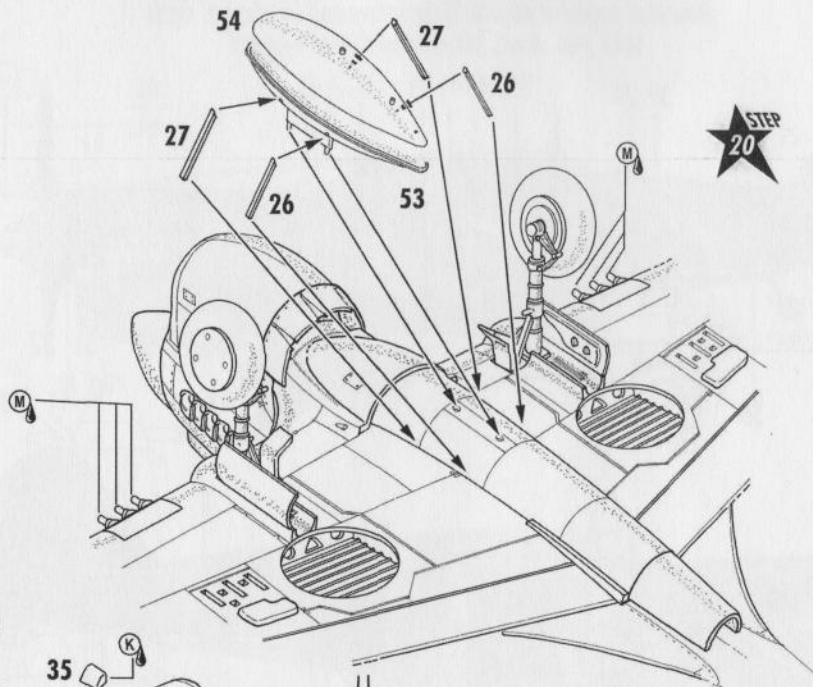
STEP  
18STEP  
19STEP  
21STEP  
20

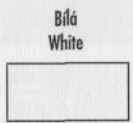
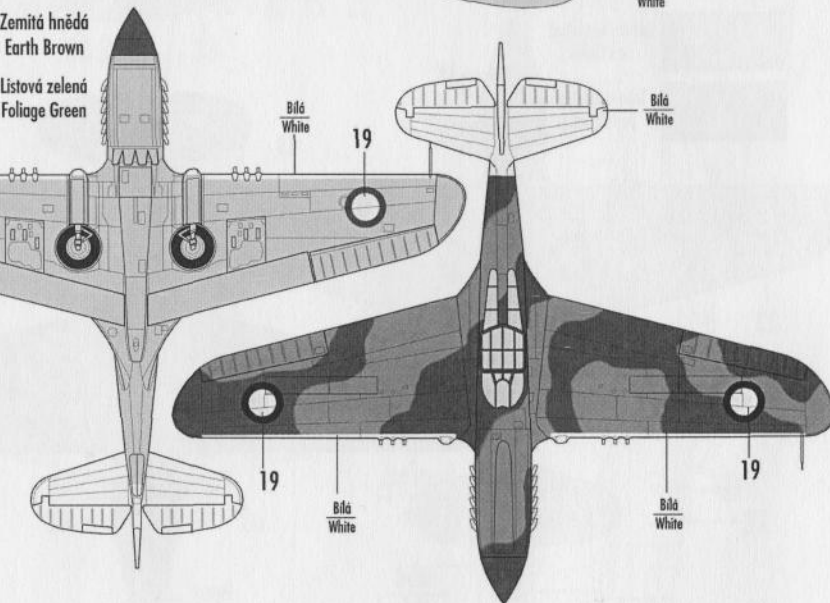
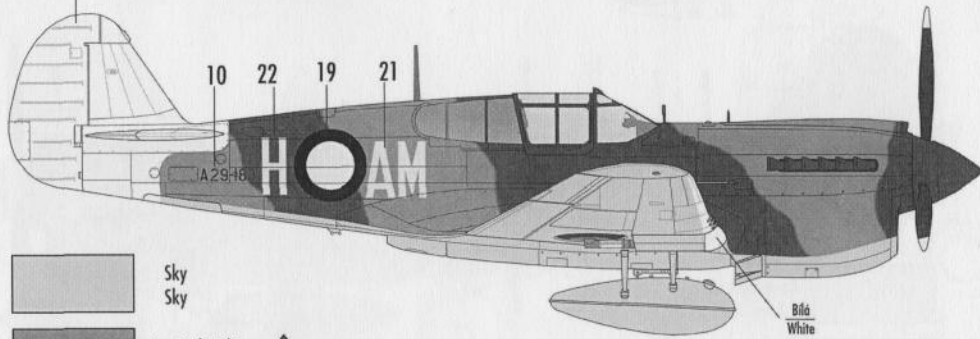
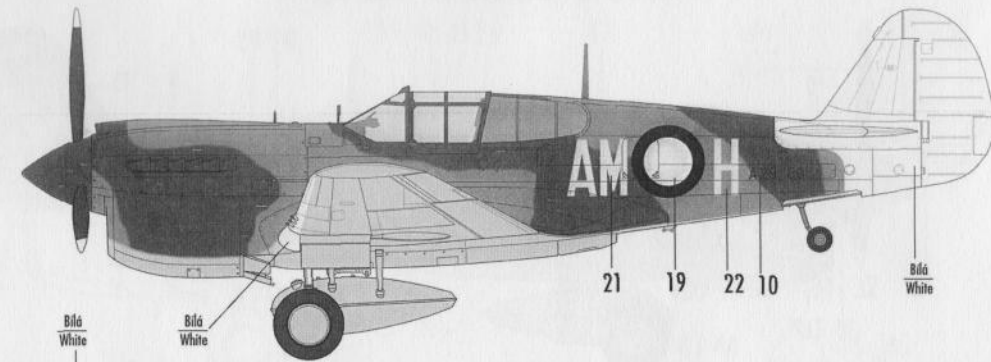
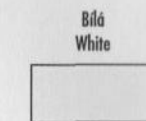
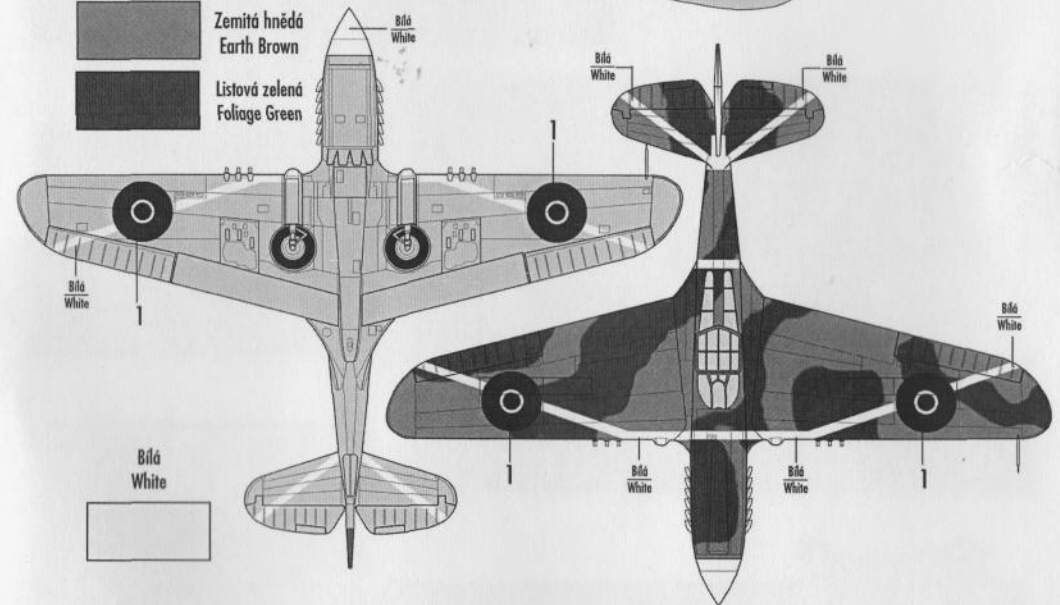
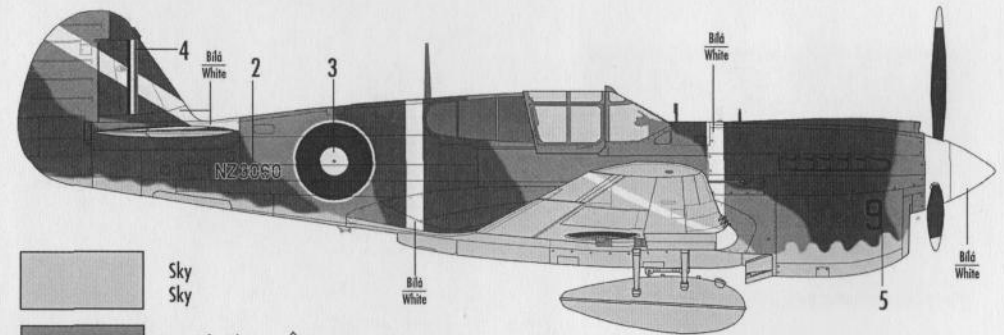
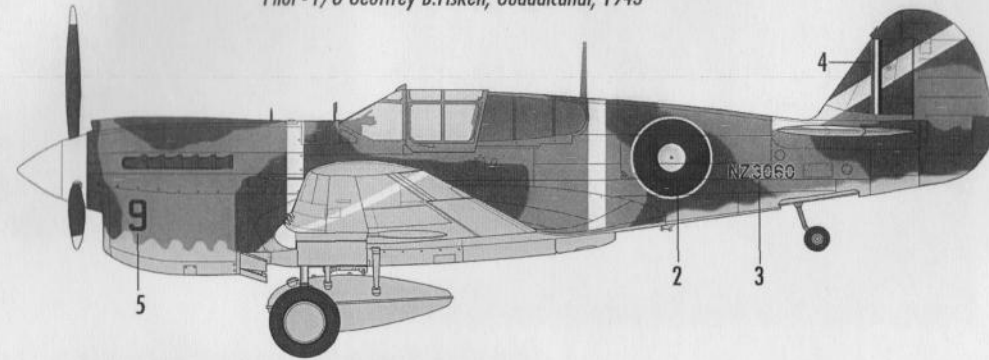

Curtiss P-40K-10, 77 Squadron RAAF, February 1944

Curtiss P-40K-15, 14 Squadron RNZAF,  
Pilot - F/O Geoffrey B. Fiske, Guadalcanal, 1943

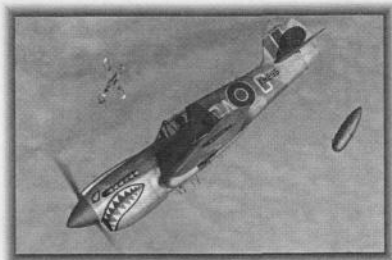
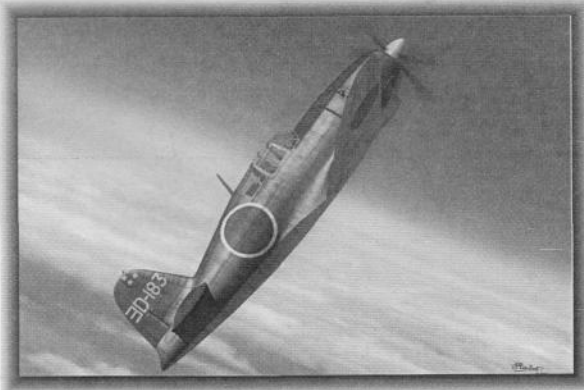

**Sword**