

INSTRUCTION

SUR LE

Montage et peinture

Automitrailleuse modèle 1914

Type ED



sku: 35013

échelle: 1/35

FRENCH ARMORED CAR MODEL 1914 (TYPE ED)

The French saw a use for armed scouting cars as early as 1898, and machine guns were mounted in French cars beginning in 1902, though these were initially created by private ventures and not at the behest of the French military. One document from 1907 calls for the need for machine gun-equipped automobiles to accompany cavalry units and use their mobility and firepower to support them in their maneuvers.

It was soon clear to some that to survive on the battlefield, the armed cars would also need armour and the ability to traverse difficult terrain. An early attempt that saw limited production was the Automobile de Guerre (War Car) CGV (for the designers Charron, Girardot & Voigt) 1906. They were sold as export models to Russia for both army and police use, though three were in France at the beginning of World War I awaiting delivery to Russia and were put into French service. It featured an armoured body, a Hotchkiss machine gun, and had removable rails that could be placed in front of the wheels to allow it to traverse uneven terrain.

Other manufacturers, including Panhard (equipped according to Captain Genty's views), Hotchkiss and Clément-Bayard, worked to develop a viable armed car design, but there was some disagreement as to how best to employ them. Would they be able to traverse difficult terrain in a combat environment? How light or heavy should they be? Should they be armed with a machine gun, multiple machine guns, or even cannon? Should they be fully armoured, partly armoured, or unarmoured and very fast?

At the outbreak of World War I, despite having used armed cars in Morocco and the fact that several French officers had advocated for their further development and use, the French Army only had eight armed cars in service on Aug. 1, 1914, and they were not included in the army's official equipment list.

When war broke out, French soldiers reported that German units in Luxembourg were accompanied by armed cars, and that French cavalry units needed them as soon as possible. Civilian cars were quickly armed with improvised machine gun mounts and pressed into service, but they were generally ineffective at first. The need for armour was proven, and as three of the CGV Automobiles de Guerre were pushed into service, other firms began developing their own armoured cars.

A number of Peugeot 146 cars were equipped with 37mm cannon, and they were successful enough for General Gallieni to order 192 of them, though General Joffre cut the number in half several days later. They were crewed wholly or in part by naval personnel.

Out of the multitude of vehicles put into frontline service, cars made by Renault stood out. The Ministry of War asked for vehicles that had enough armour to stop the German "S" bullet (the S stood for *spitze* - pointed) at 200 meters.

After reviewing designs, the first armoured car produced in large numbers was the Renault blindée -



Illustration 1. Renault armored car on a road somewhere in Champagne, France. Freshly put into service, car 17843 still looks almost new, but it has received its military registration, painted black on the sides and white on the front, a curious mixture. 1915.

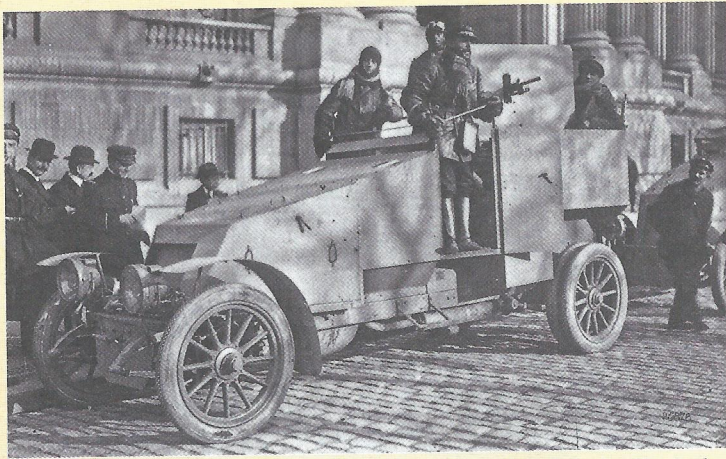

Illustration 2. Taken in front of the Grand Palais in Paris in December 1914. Two small tricolor flags are painted on the bonnet, but another photograph of the same car reveals other details: The registration number 46430 drawn in chalk on the left side, under the flag and, even more interesting, the ZM 26 marking on the front of the hood, which identifies it as belonging to the 7th group.

point for the full crew. A wide armoured louver gave the driver protection, or it could be raised for better visibility.

While none of the Model 1914 Renault armoured cars exist today, and technical information and specifications are impossible to confirm with certainty, it's possible to tell from period photos some of the vehicle's specifications. Its wheelbase was 3.56 meters (Renault ED standard), with an 18-hp engine (which was also sometimes designated as a 20-hp engine). The engine had four cylinders and measured 95x160mm with a displacement of 4,536 cc. The radiator was placed behind the engine, inside the fighting compartment. Though it provided more protection from damage, its location caused it to provide



Illustration 3. The special device visible on the right side of this armoured Renault is the first known example of an inverter on a French armoured car. Organized in a perfectly inconvenient way, it was not to be adopted. The other interesting aspect of this photograph is to show markings on the rear of the car, a detail rarely observed. The machine gun is in position for firing against aircraft. Winter 1915-1916.

the armoured Renault, which was built in Lyon, an armoured Car now known as the armoured Car Model 1914 (Type ED). The Renault company was one of the leaders of France's strong prewar auto industry, and their ED cars provided a proven design upon which to base an armoured car. Initially, the French Army ordered 100, but that was later reduced to 60 – enough to equip 15 groups. The first ones went into service on Oct. 25, 1914.

The Renault armoured cars were equipped with an 8mm St. Etienne machine gun on a raised mount in the open-topped rear compartment that fired over the armour and had its own armoured shield. In the front compartment sat the driver, and the rear compartment had space for a loader and a gunner. A single door on the left side of the front compartment served as the entry

insufficient cooling, and it was prone to boiling over. In combat, it was further determined that the engine provided insufficient power. Spare wheels and tires were carried internally, located at the junction of the front and rear areas of the fighting compartment, and the vehicle ran on six total wheels – two up front and four on a single rear axle, which was common in European armoured car designs of the time.

Of 12 cannon- and machine gun-armed car sections organized in 1914, five were equipped with Renaults (Sections 1, 3, 4, 5 and 6). To differentiate them from the cannon-armed vehicles, French nomenclature stipulated that the Renaults be classified as "ZM," with Z standing for Paris and M standing for mitrailleuse (machine gun).

Early French doctrine developed by General Gallieni, military governor of Paris, for employing the armoured cars was to have them support cannon-armed vehicles – chiefly the previously mentioned Peugeot 146 models in groupes d'autos-mitrailleuses et autos-cannons (French for “groups of auto-machine guns and auto-cannons,” abbreviated as GAMAC, among other names and abbreviations). Gallieni used the fame of the French taxis that had so quickly delivered troops from the capital to the Marne to make the case for armoured cars serving as mobile artillery. The cannons provided the offensive firepower, and the lighter machine guns were to provide protection for them as they hammered away at tougher targets.



Illustration 4. This classic photograph, taken from the press of the time, was taken in March 1915. The group to which car 17414 belongs is not known. Note the MG shield removed to fire against the aeroplanes.

Despite the need to stop the German “S” bullets at 200 meters, there was concern that the 5mm armour on the Renault Model 1914s could do the job, and Louis Renault personally informed the Minister of War that he couldn’t ensure that the armour on his armoured cars was capable of meeting that requirement. Upon testing, the Ministry of War officially classified the vehicles as “insufficiently armoured.” Upgrades in 1915 saw additional armour from St. Chamond, which later made tanks, as well as extra engine ventilation and additional armour protection for the crew.

Though they were quickly superseded by future developments, the Model 1914 (Type ED) remains the first armoured car built in large numbers by the French as they sought desperately to field armoured cars that would help them stop the invading German Army before it was able to take Paris and win the war.

In addition to serving in the French Army, 40 Renault Model 1914s were purchased by Russia, and they were dismantled for transport, with the chassis and the armoured hulls being shipped separately. They arrived in July 1915, and due to their inadequate armour, the Russians used many of them as ammunition carriers, though 11 chassis were sent to the Izhora factory to be used in a project headed by Staff Capt. Mgebrov, which became the Renault Mgebrov armoured cars.



Illustration 5. Another 17935 Renault armoured car on the streets of an unknown town, again without the MG shield.

COLOURS AND MARKINGS

Renault Model 1914s were painted,

like other armed and armoured vehicles in the French Army at that time, in Artillery Grey, though at least one was camouflaged in the field with an artistic countryside scene being painted on its armoured superstructure, and at least one other was painted in a four-color camouflage scheme that would become familiar as the war went on.

The "artillery grey" shade (a very light grey-blue) was adopted, by decision of December 21, 1896, for the new 75 mm model 1897 gun. It was then to be used for all equipment subsequently adopted by the French Army, whether artillery or vehicles (horse-drawn carriages, then automobiles).

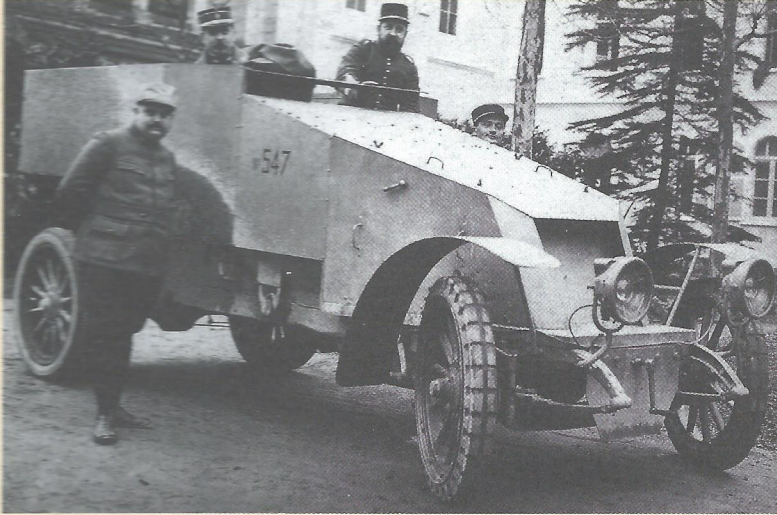

Illustration 6. This beautiful armoured Renault N° 547 with Ducasble tires is perhaps one of those not attributed to the navy groups. Its staff comes from the automotive service.

We can assume that the same is true for Renault N°552 car represented in this kit's markings (but the front tires were regular)



Illustration 7. This "armoured Renault" without a visible number presents a very fine example of multicolored streaking, each zone with irregular shapes being hemmed with a black or dark brown net. This car is likely from the 10th group. Probably Spring of 1915.

Text by François Vauvillier

Translated and edited by Brandon Darnell

Images provided in the article are from the François Vauvillier Collection

Important Notes

- Read the instructions carefully before starting the assembly.
- Use glue intended for plastic models.
- Choking hazard. Keep small parts and plastic bags away from children.
- Always wear protective eyewear when cutting and a protective mask when painting, glueing and sanding.
- Use paints designed and suitable for plastic model kits.

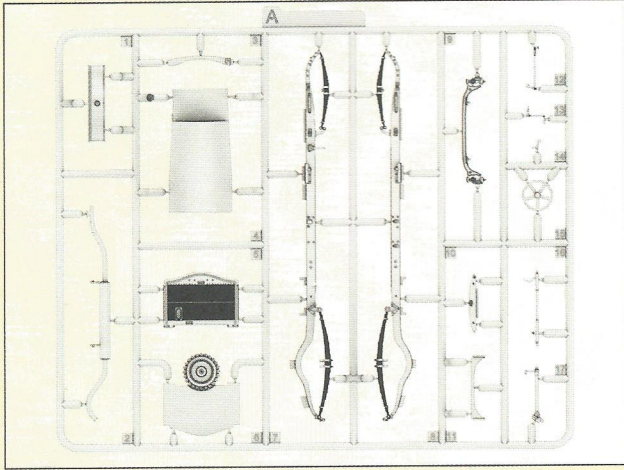

Fig. 1. Runner A

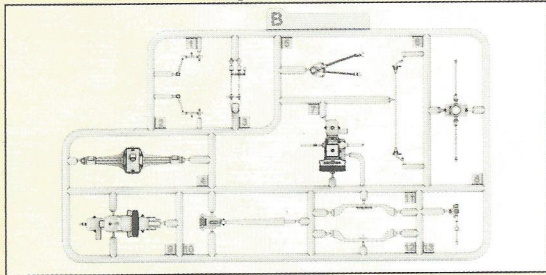

Fig. 2. Runner B

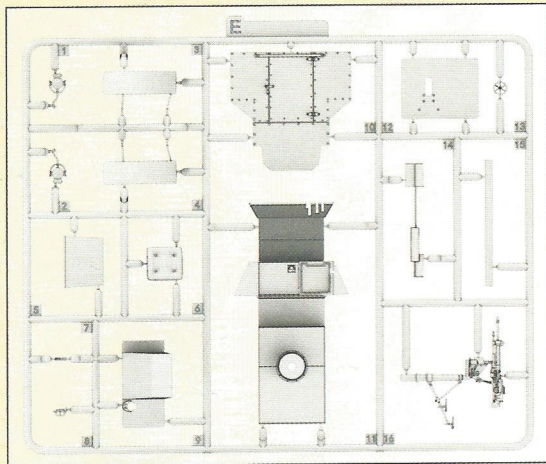

Fig. 5. Runners E

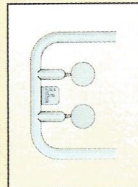

Fig. 6.
Runner F

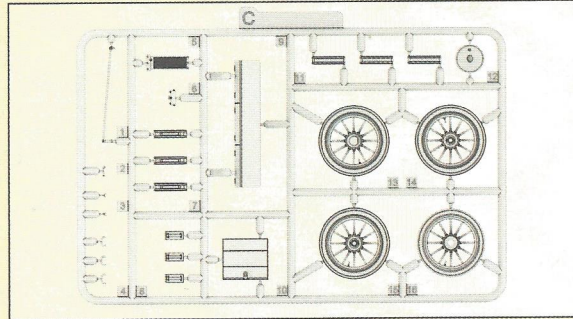
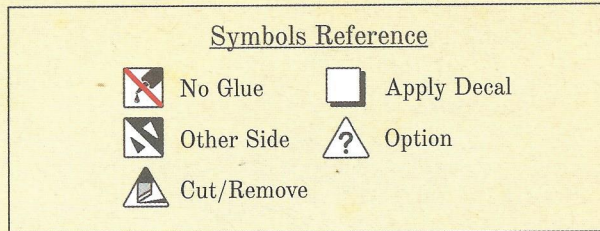

Fig. 3. Runner C, x2

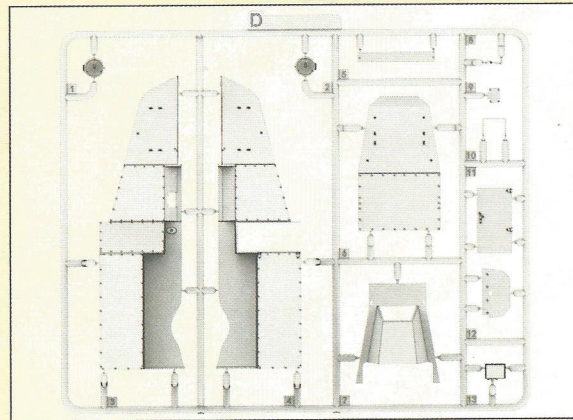

Fig. 4. Runner D

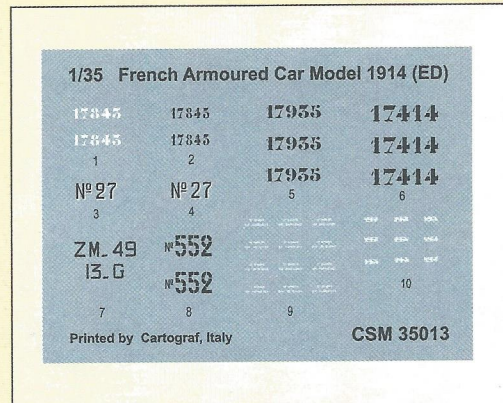
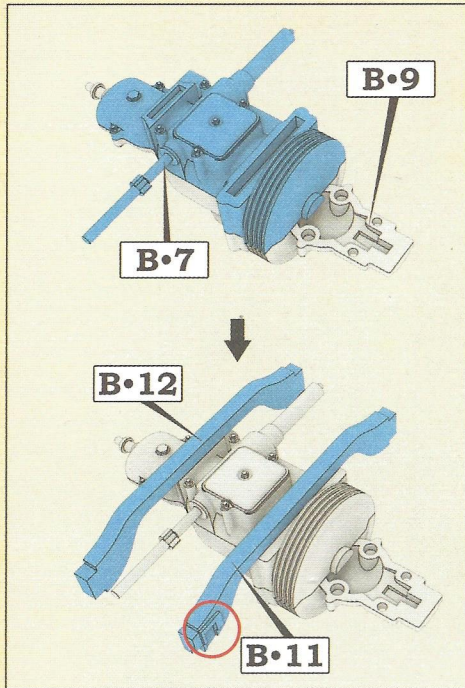

Fig. 7. Decals

Colour numbers

1 Burnt metal (exhaust)	5 Black	9 Grey green	13 French ochre
2 Rubber (Grey)	6 Brass	10 French artillery grey	14 French artillery blue
3 Leather	7 Wood	11 French brown	15 Linoleum red
4 Aluminum	8 Gun metal	12 French green	16 Steel

RC 246 / RC 321



Step 1. Assembling the gearbox

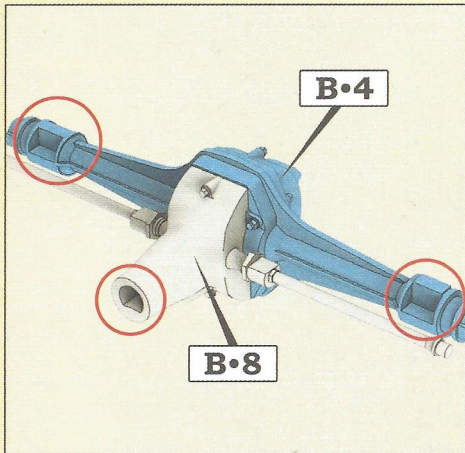

Step 2. Assembling the rear axle

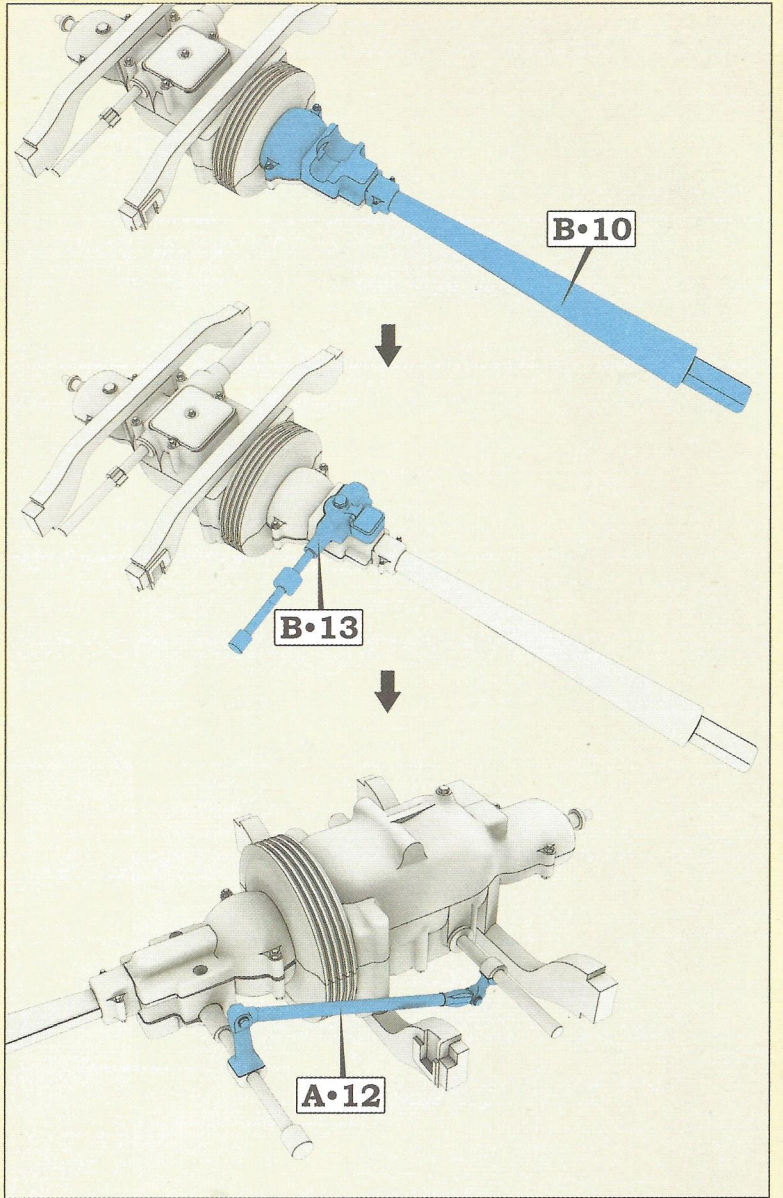

Step 3. Installing the drive shaft

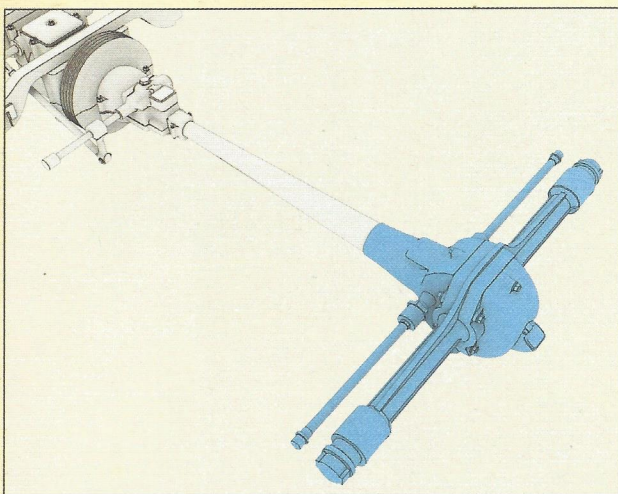

Step 4. Installing the rear axle

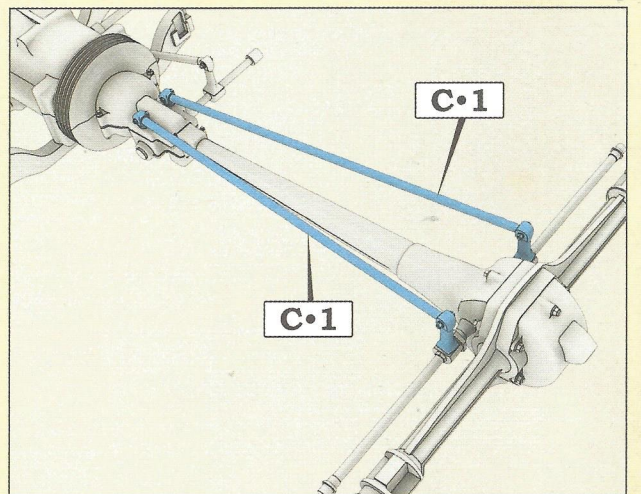

Step 5. Installing the rear radius rods

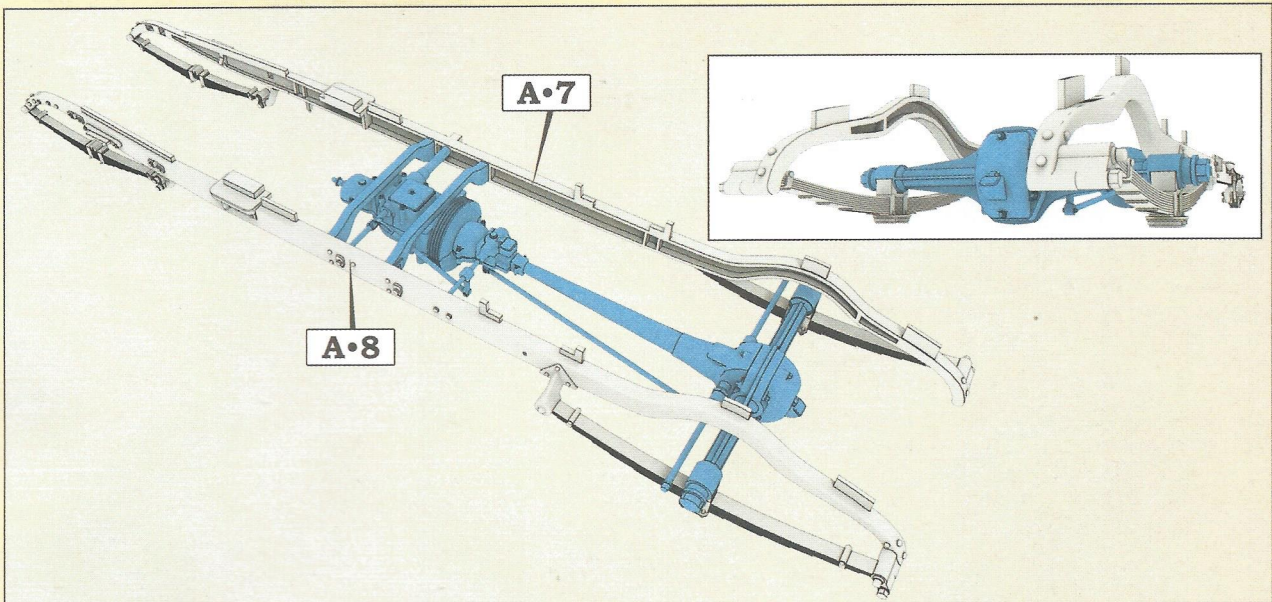

Step 6. Installing both side rails

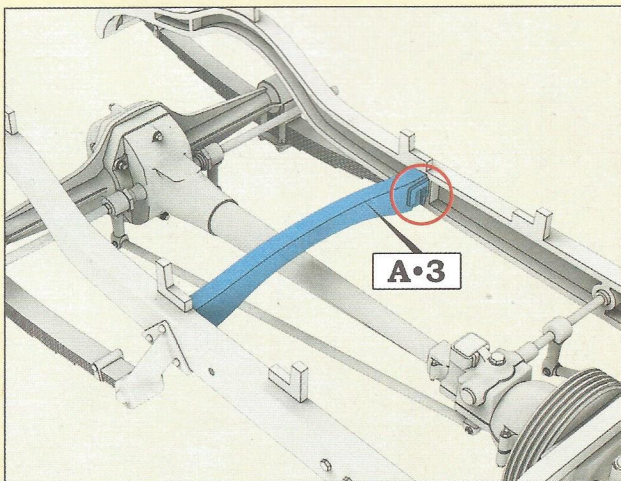

Step 7. Installing the cross member

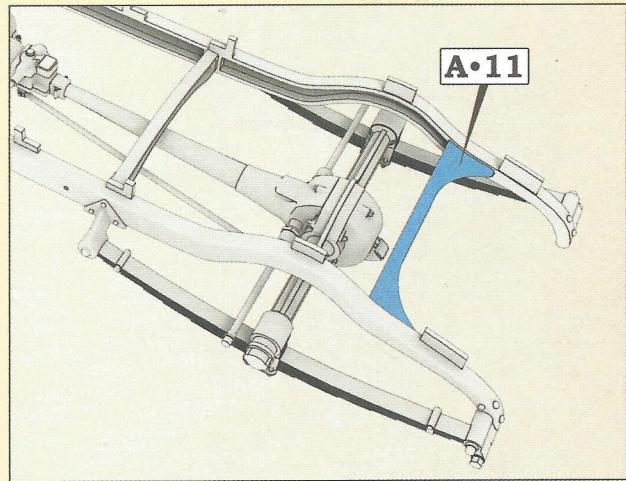

Step 8. Installing the rear cross member

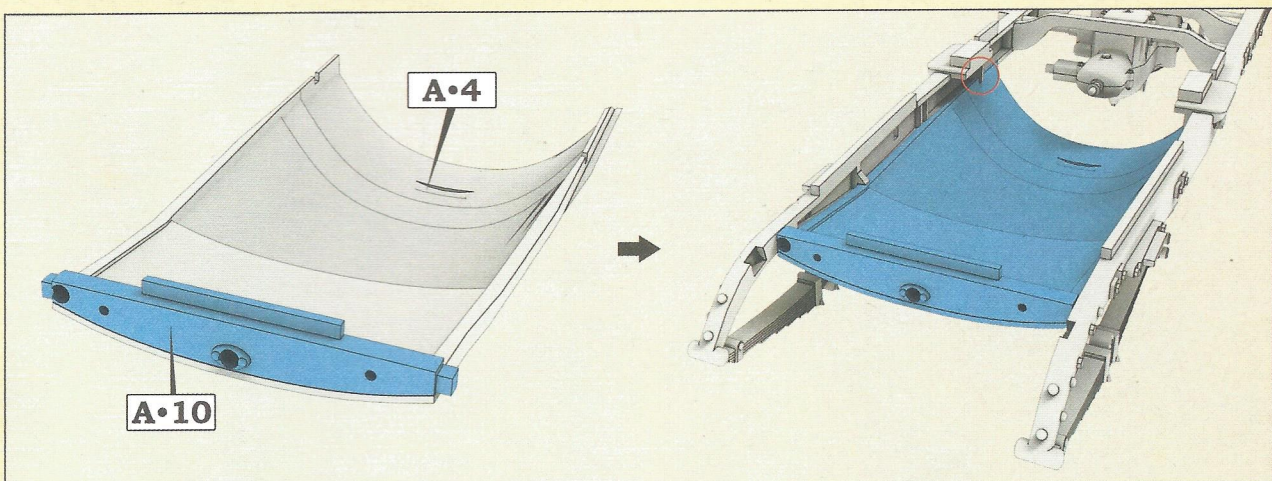

Step 9. Installing the front cross member with engine protection

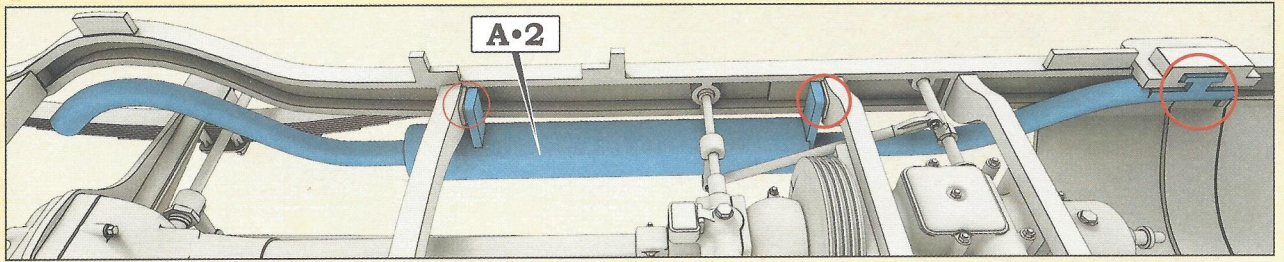

Step 10. Installation of the exhaust pipe with muffler

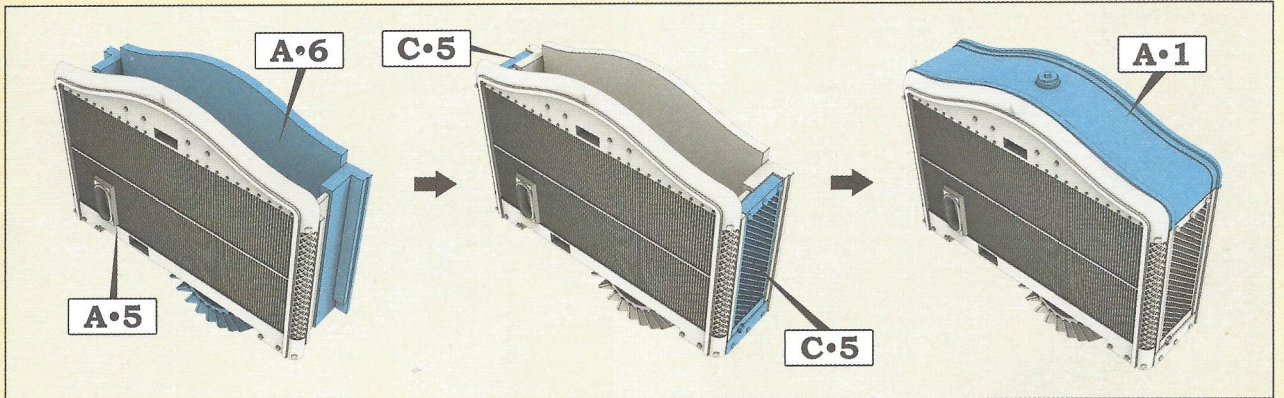

Step 11. Assembling the radiator

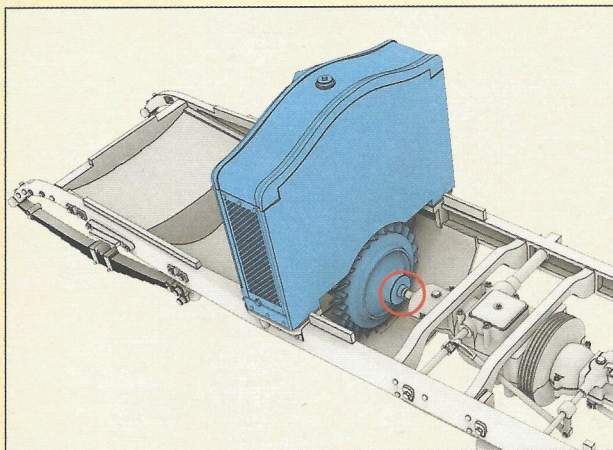

Step 12. Installing the radiator

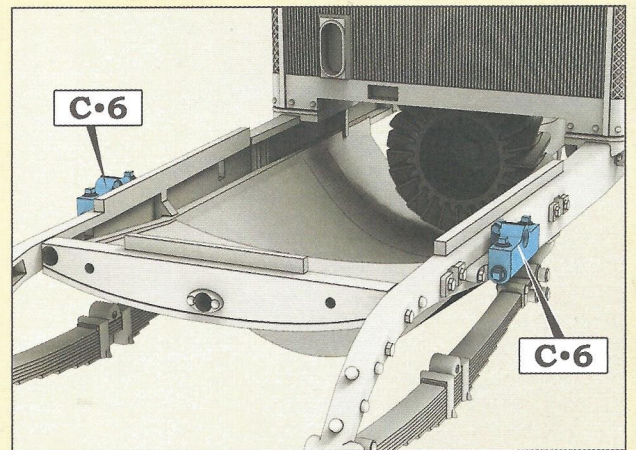

Step 13. Shock absorber blocks installation

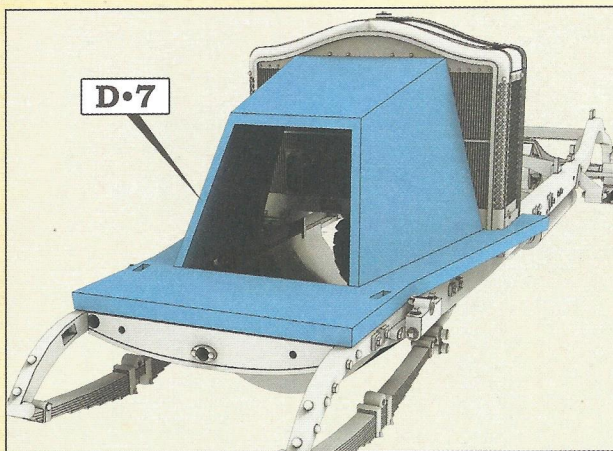

Step 14. Installing the engine protection

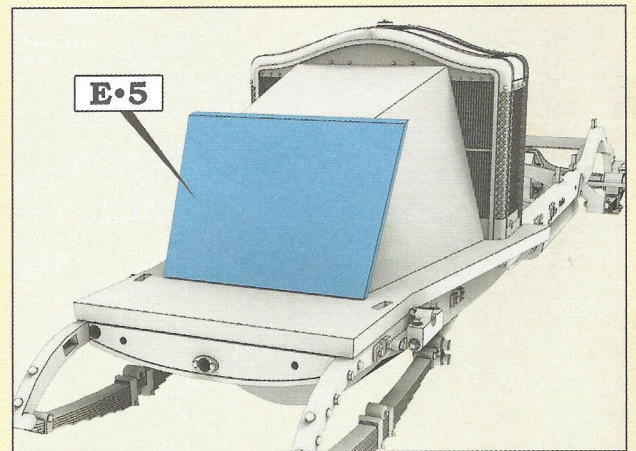

Step 15. Installation of the front engine armour plate

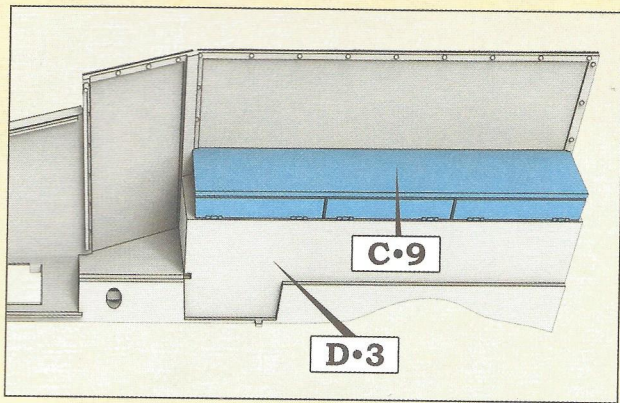

Step 16. Installing the starboard stowage boxes

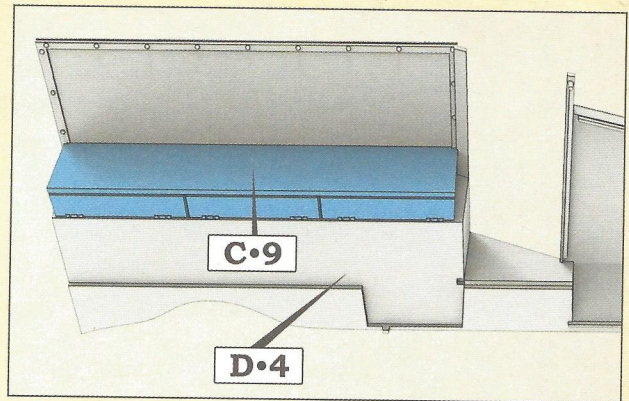

Step 17. Installing the port stowage boxes

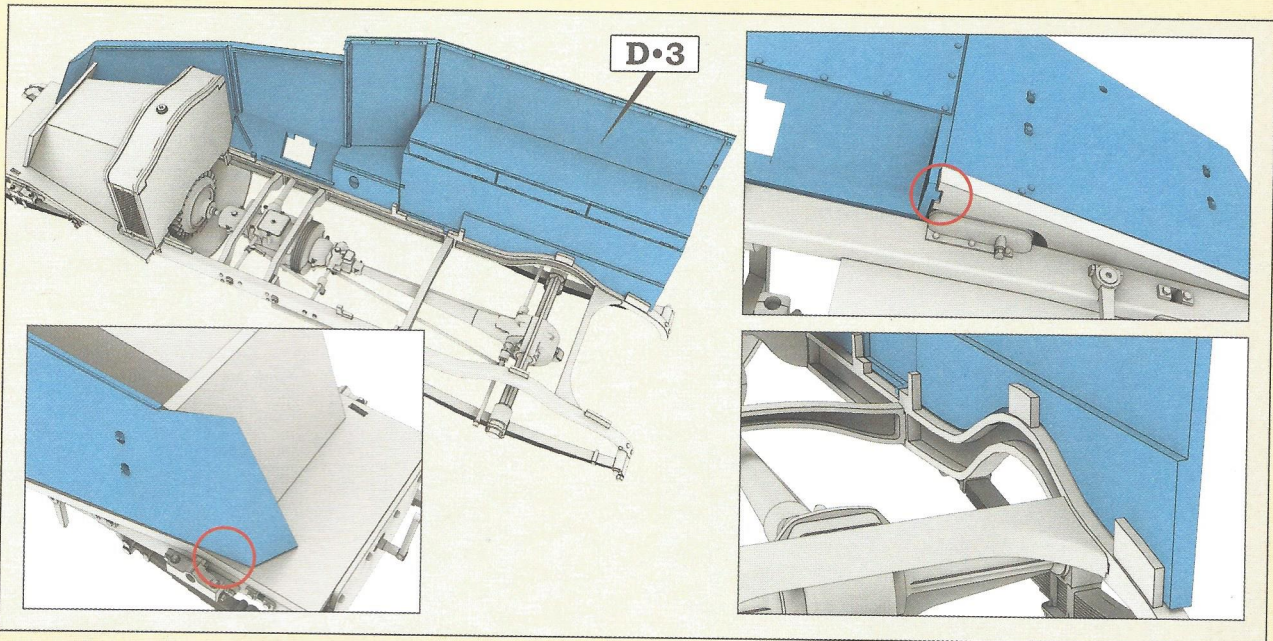

Step 18. Installation of the starboard armoured superstructure wall

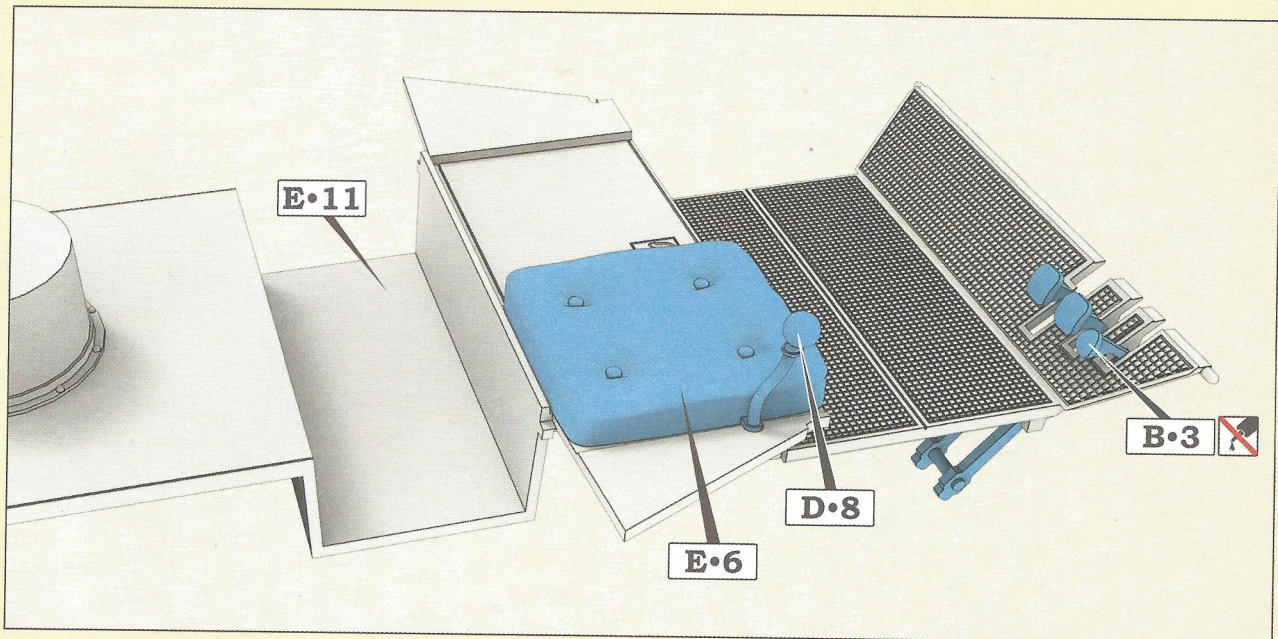

Step 19. Installing the pedals and the driver's seat

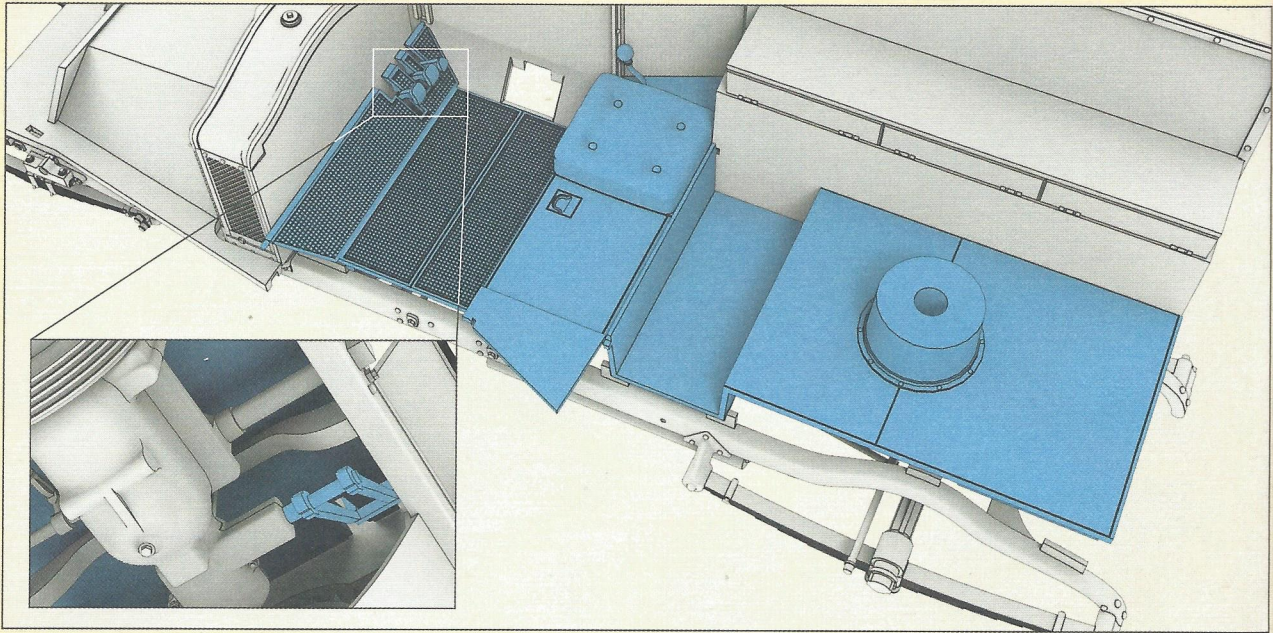

Step 20. Installing the floor into the armoured superstructure

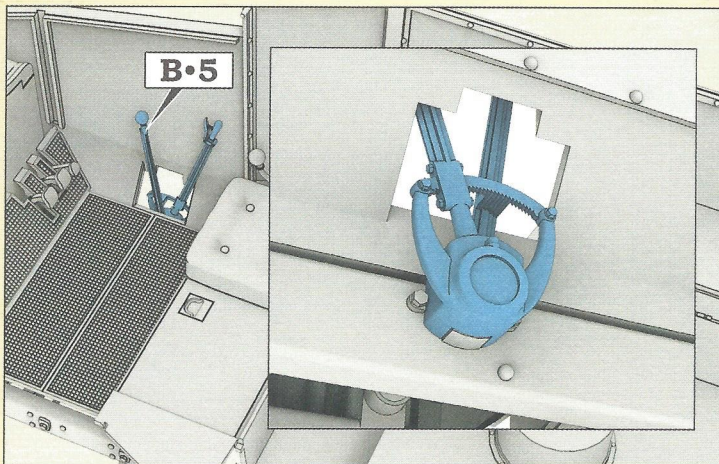

Step 21. Installation of the gear and handbrake levers

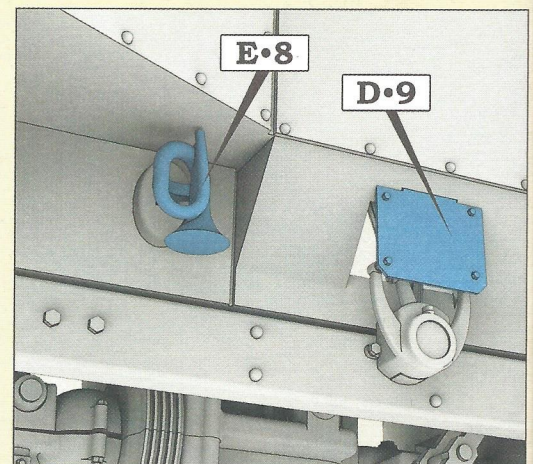

Step 22. Installing the horn and protection

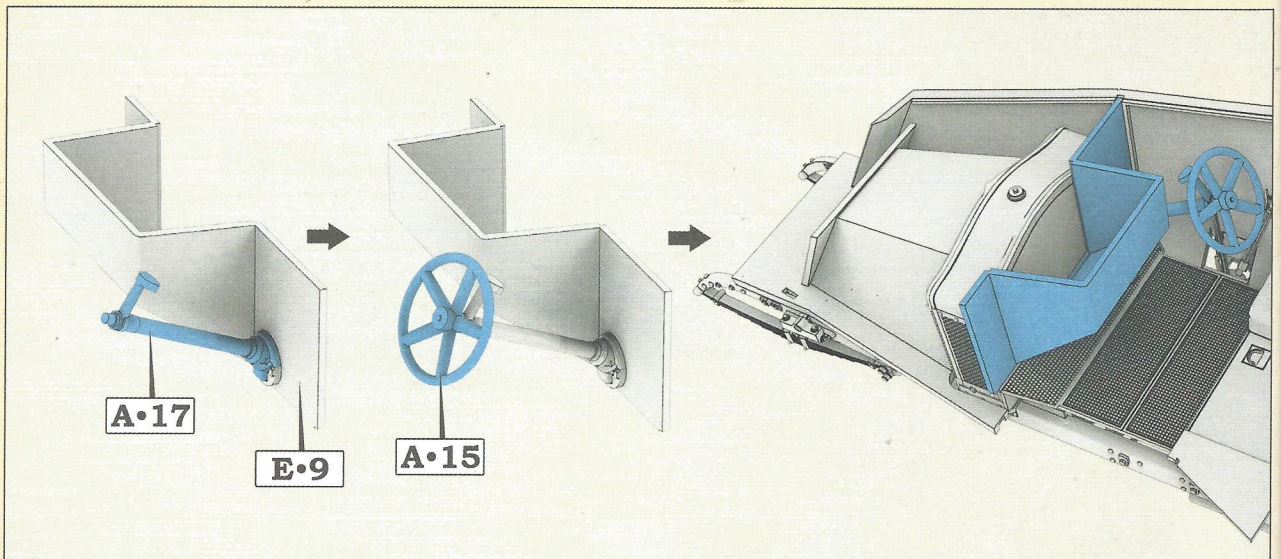

Step 23. Assembling and installation of the steering wheel and the fuel tank

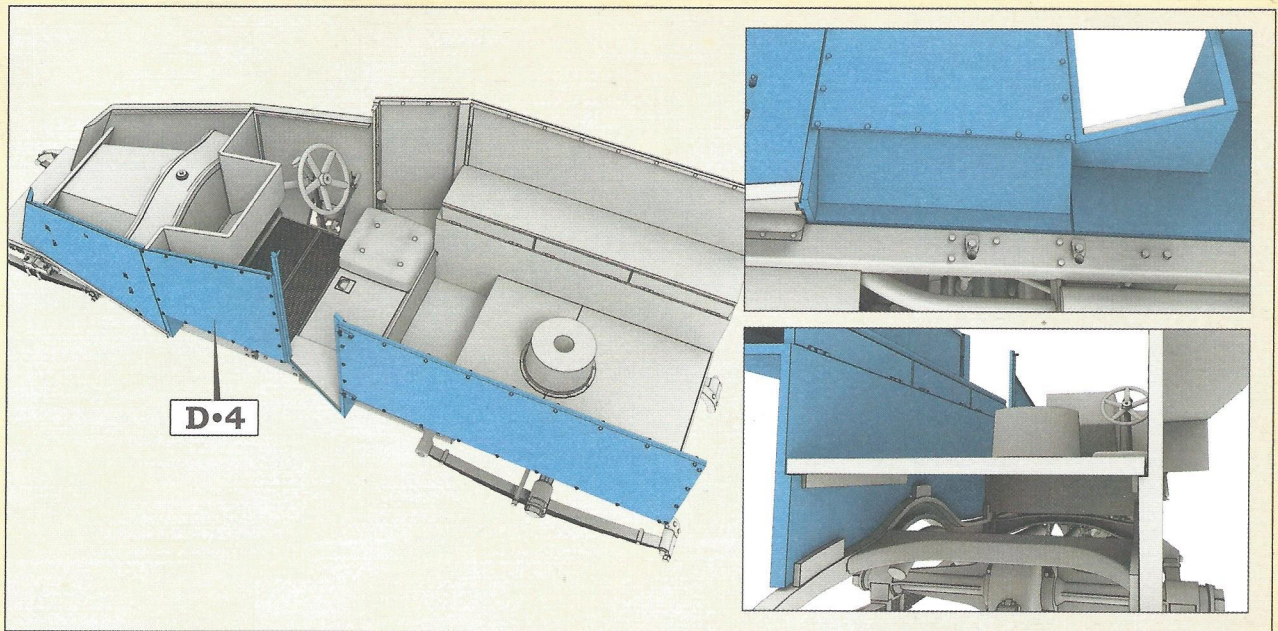

Step 24. Installation of the port armoured superstructure wall

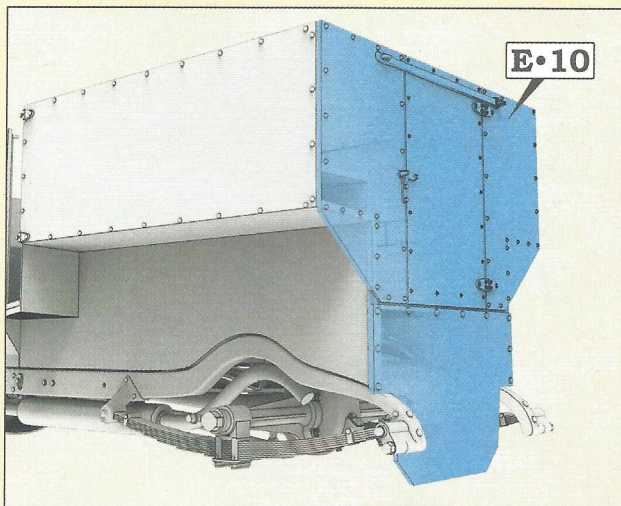

Step 25. Installation of the rear armour

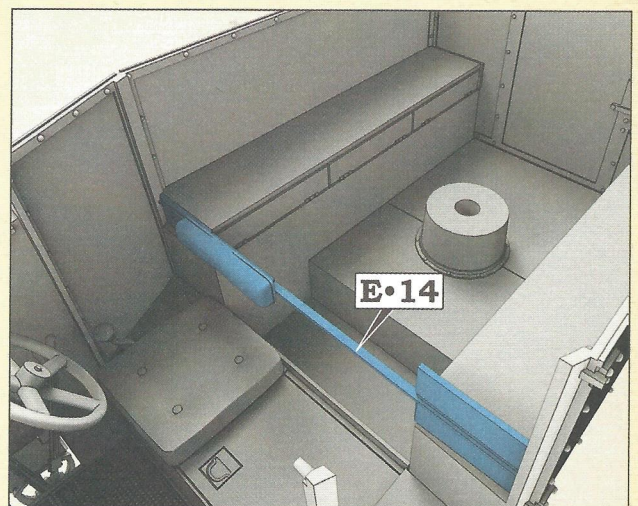

Step 26. Installing the driver's backrest with the compartment cross member

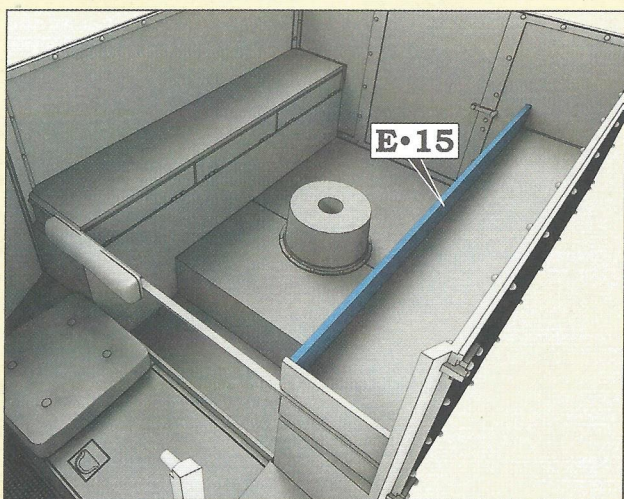

Step 27. Installing the side wall for ammo storage

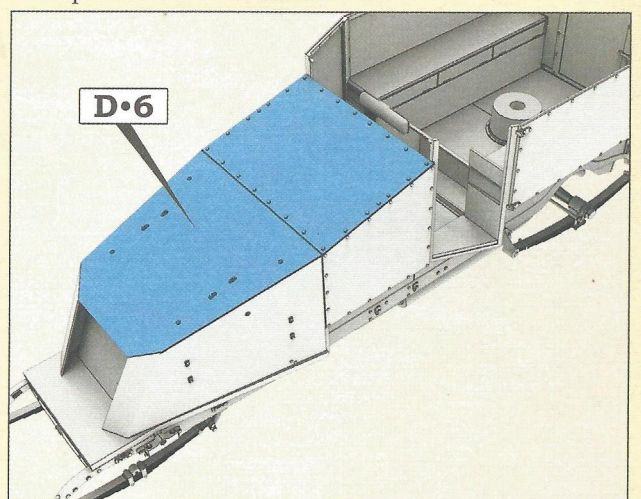

Step 28. Installing the engine hood

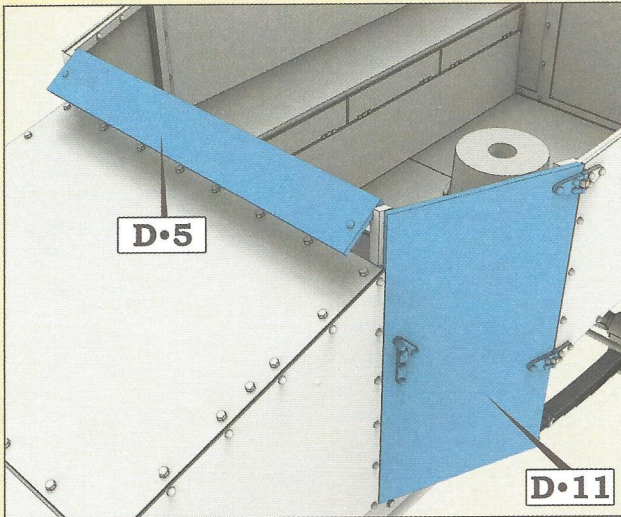

Step 29. Installing the crew door and driver's hatch

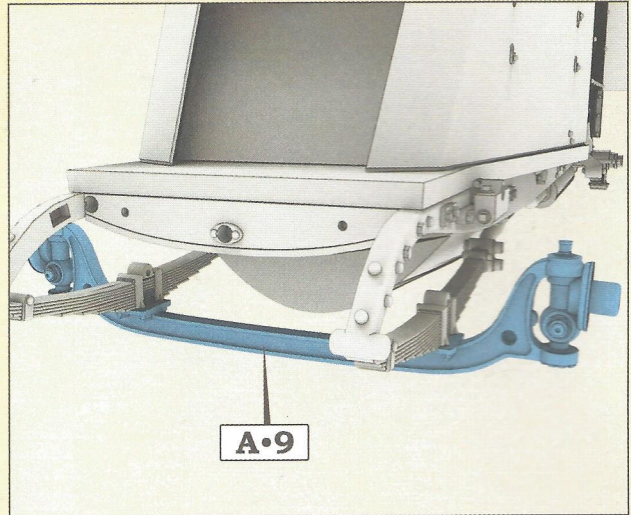

Step 30. Installation of the front axle

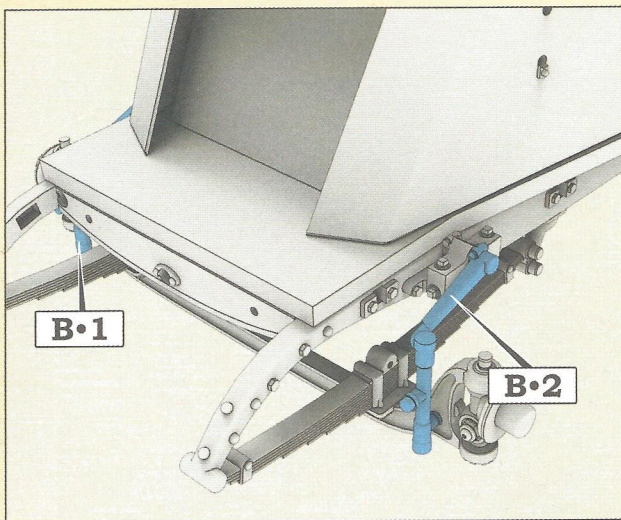

Step 31. Installation of the lever arm shock absorbers

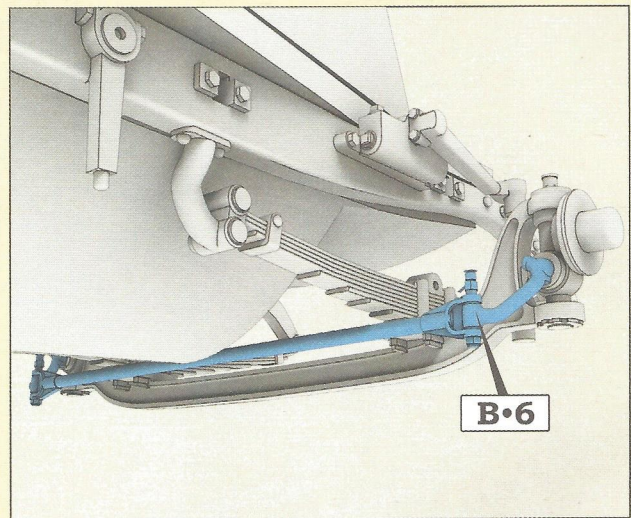

Step 32. Installing the track-rod

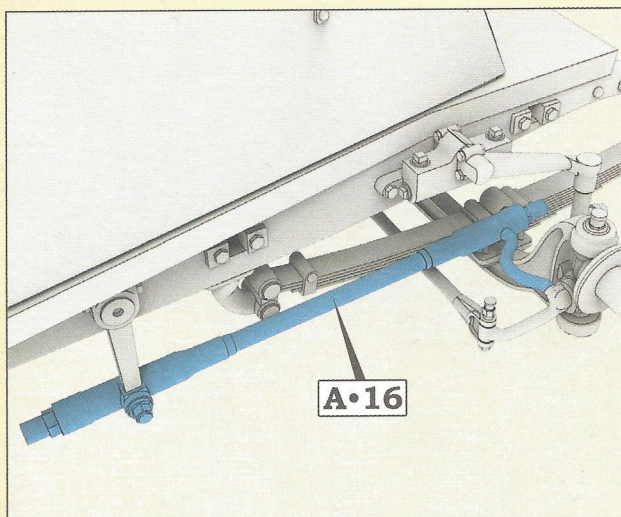

Step 33. Installation of the steering arm

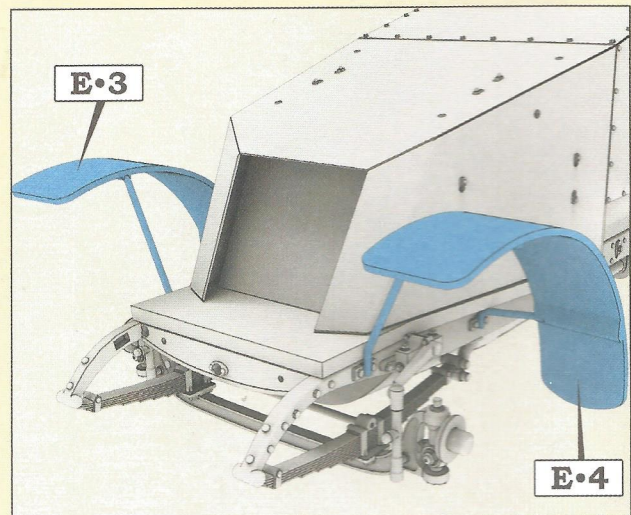

Step 34. Installation of the front fenders

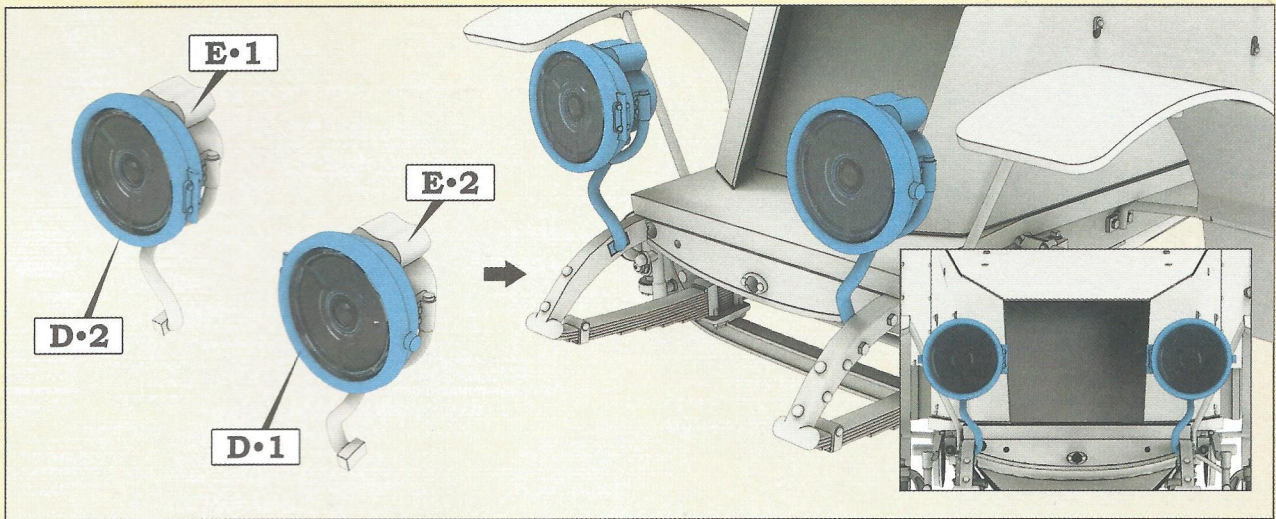

Step 35. Assembling and installing the headlights

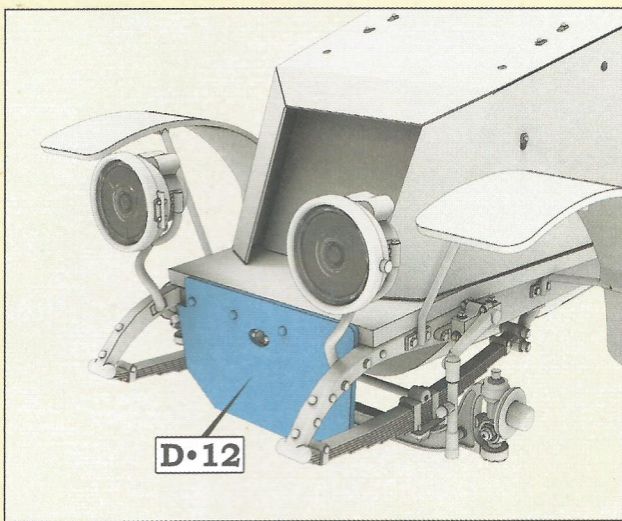

Step 36. Installing the crankcase protective plate

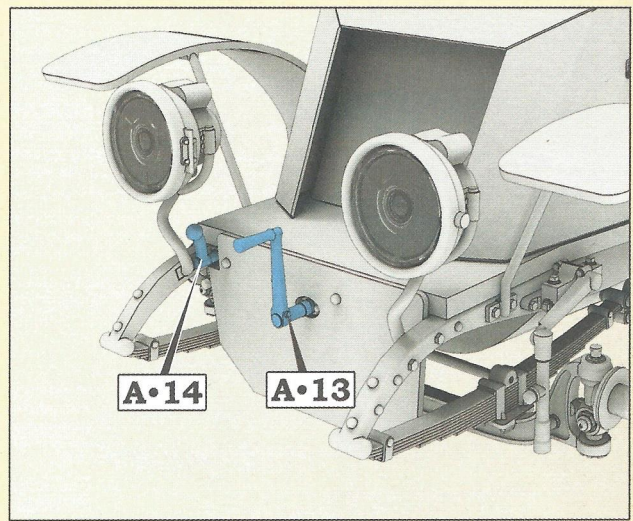

Step 37. Installing the lever and hand crank

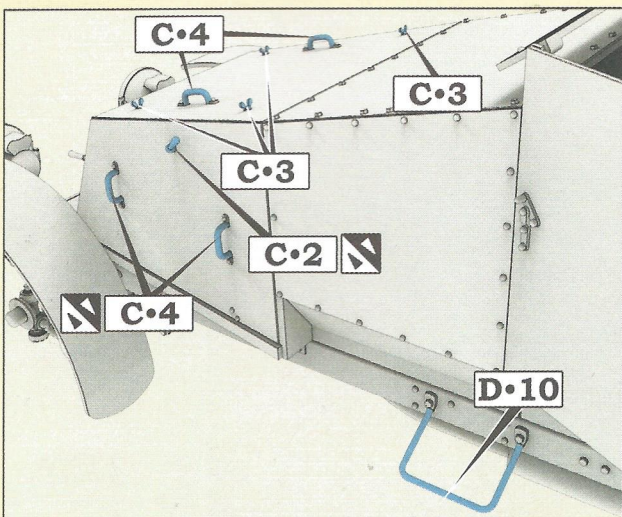

Step 38. Installation of the handles, wing nuts and crew step

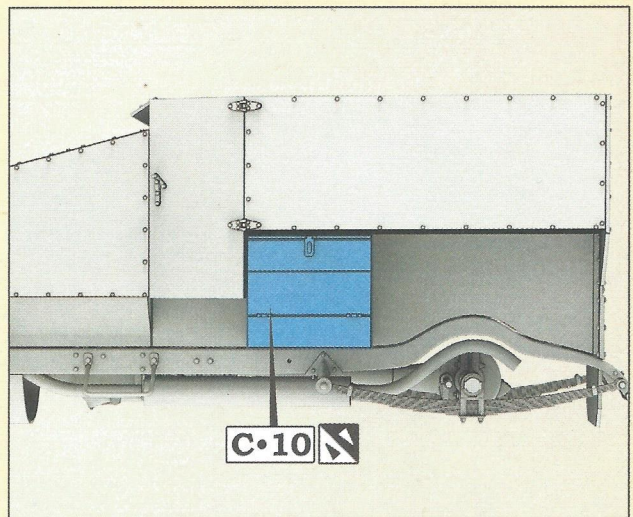

Step 39. Installation of the outside stowage boxes. On both sides of the car

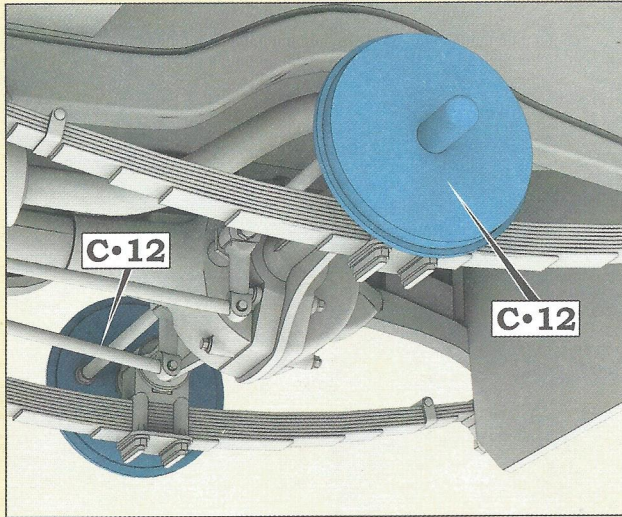

Step 40. Installation of the rear wheel brake drums

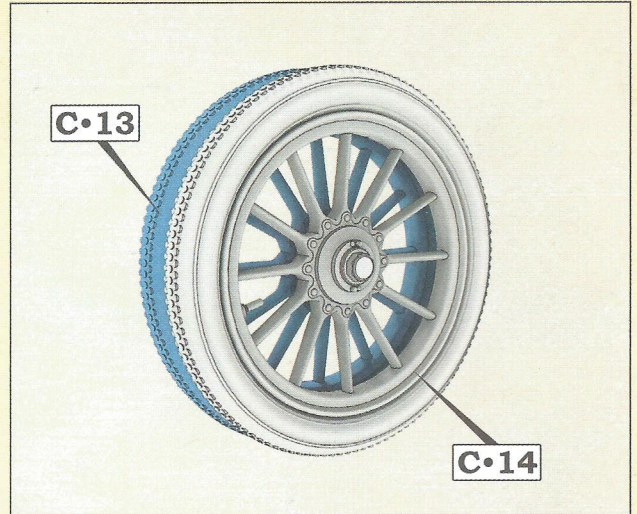

Step 41. Assembling the rear twin-wheel

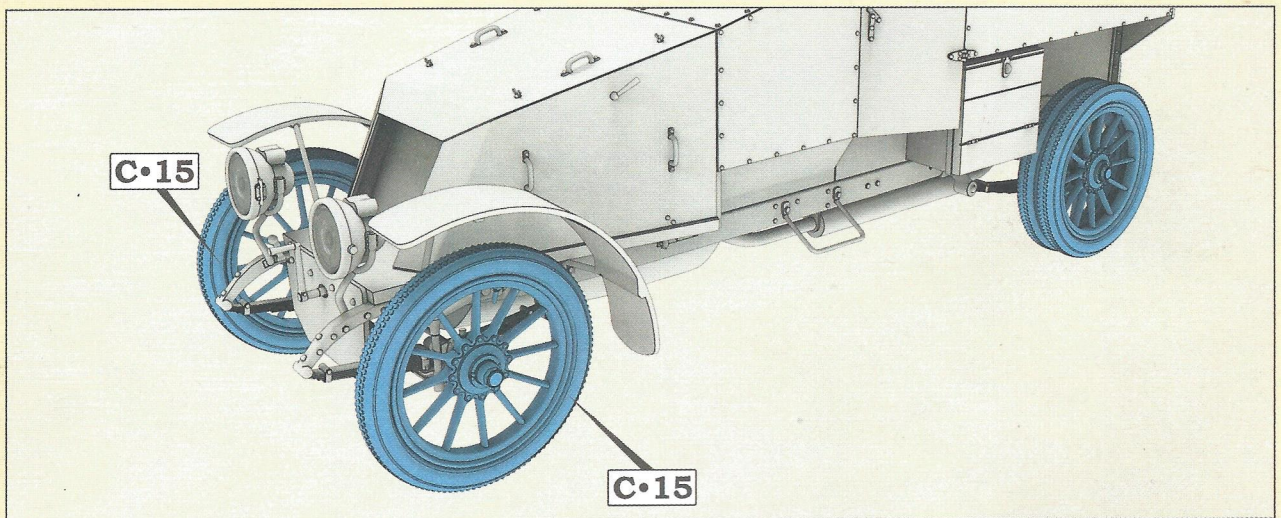

Step 42. Installation of the front and rear wheels

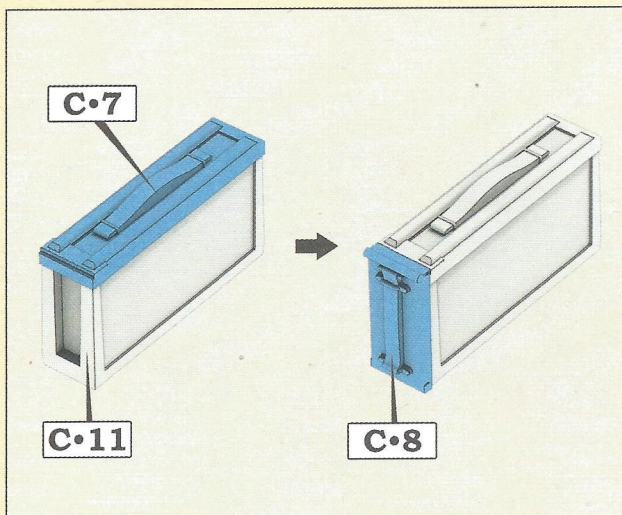

Step 43. Assembling the ammunition boxes. Make six

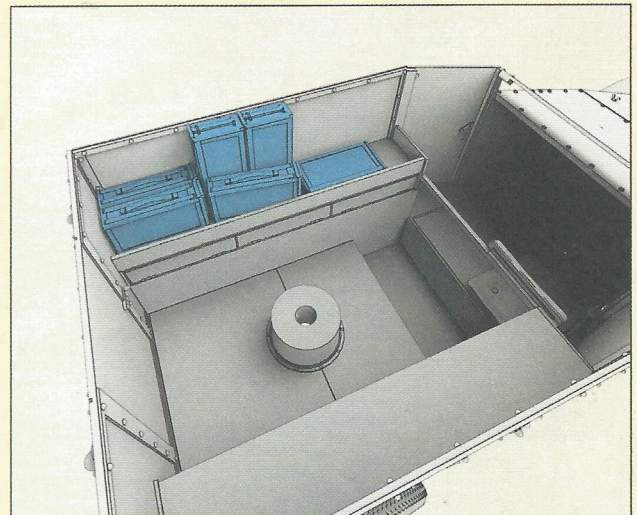

Step 44. A possible layout of the ammo boxes

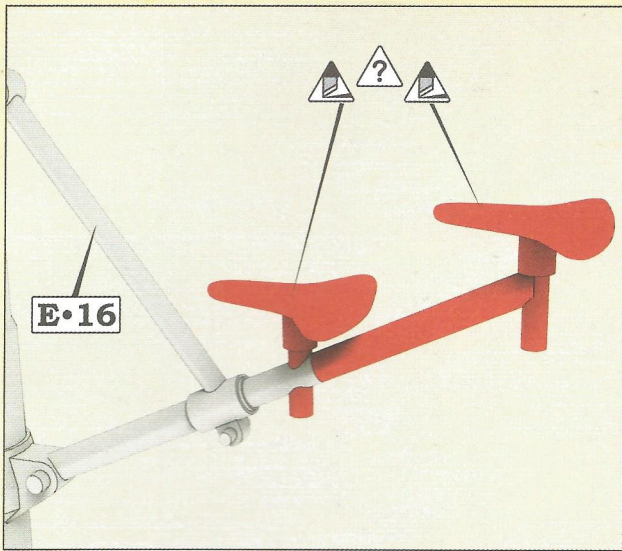

Step 45. Gunner seat possible length options. Fully extended when gunner is sitting

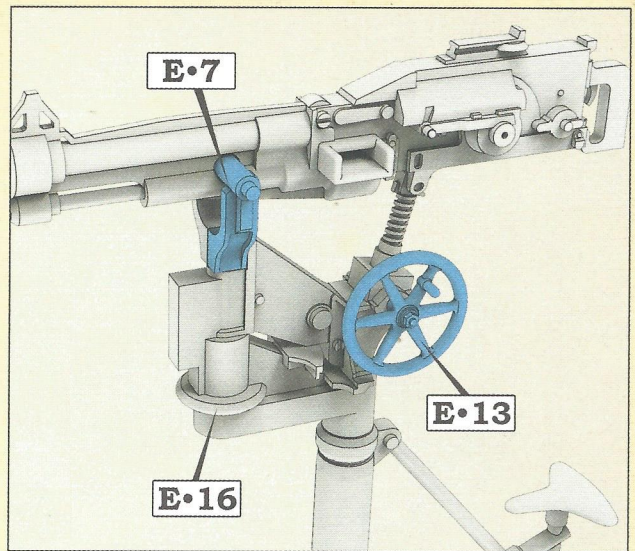

Step 46. Assembling the Saint-Étienne MG mount

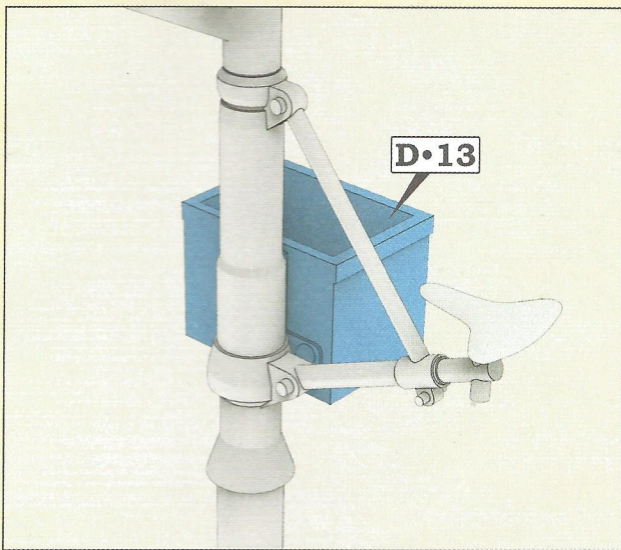

Step 47. Installing the box for empty strips

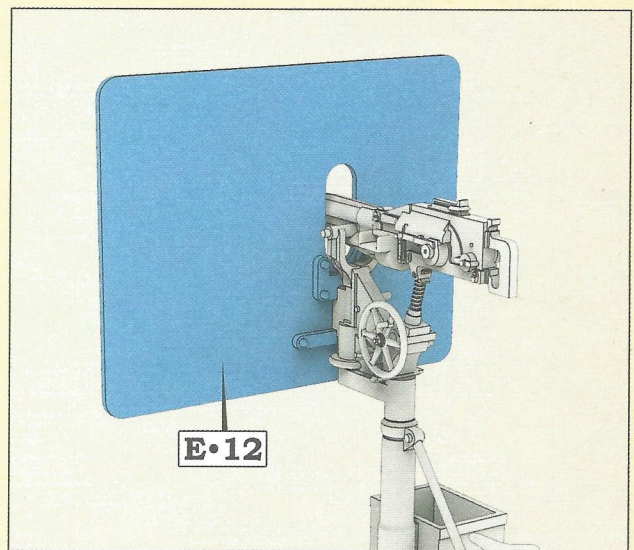

Step 48. Installing the MG shield. Not for all markings

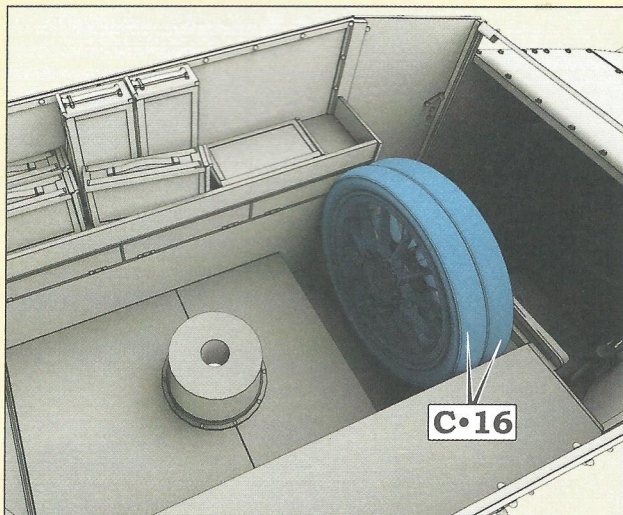

Step 49. Installing the spare wheels

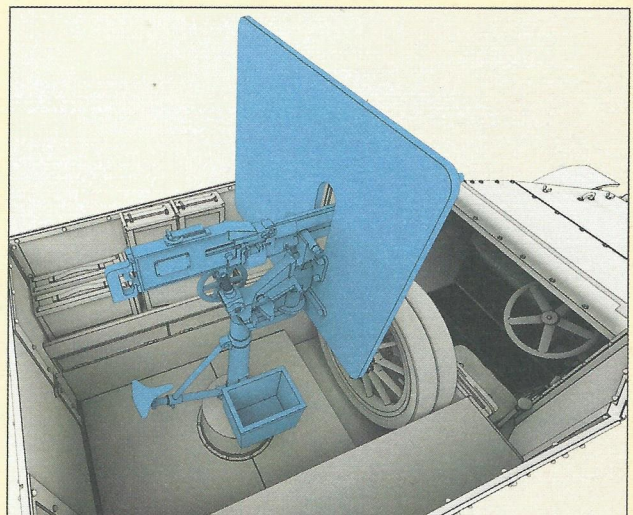

Step 50. Installing the MG into the car

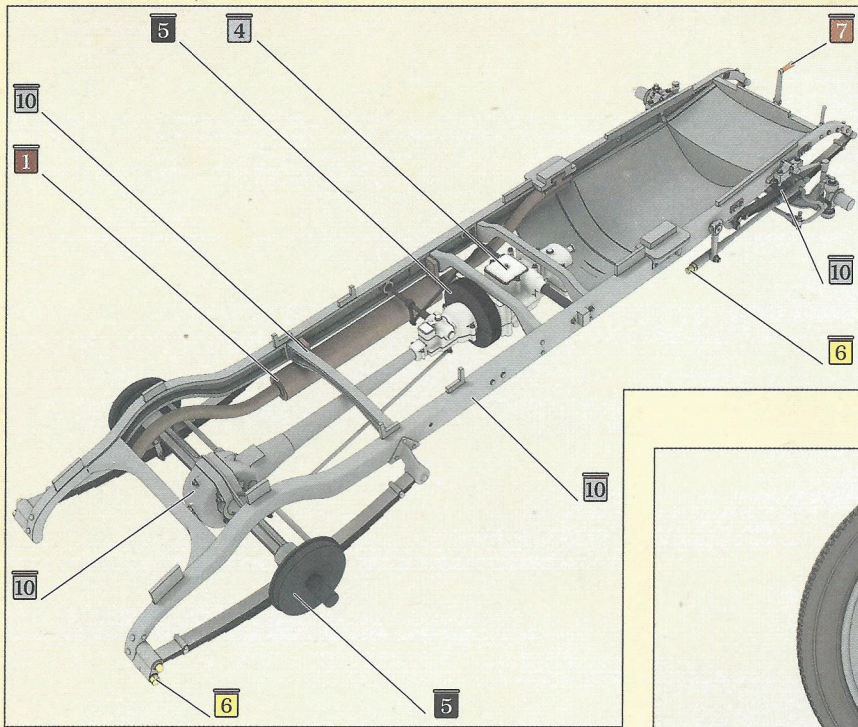

Fig. 8. Colours for the chassis

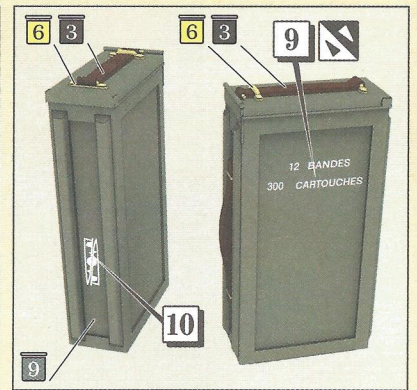

Fig. 9. Ammo boxes

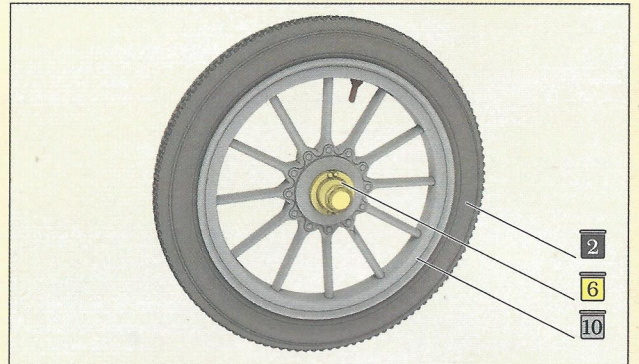

Fig. 10. Wheels

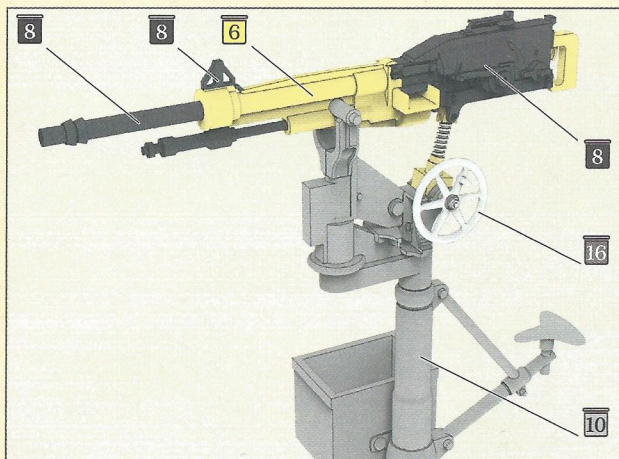

Fig. 11. Saint-Étienne Machine Gun

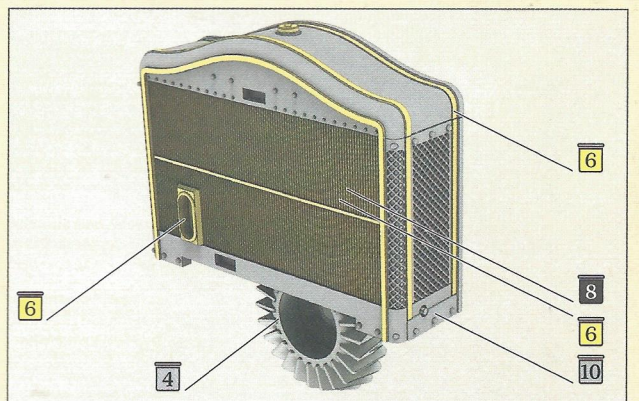

Fig. 12. Radiator colours

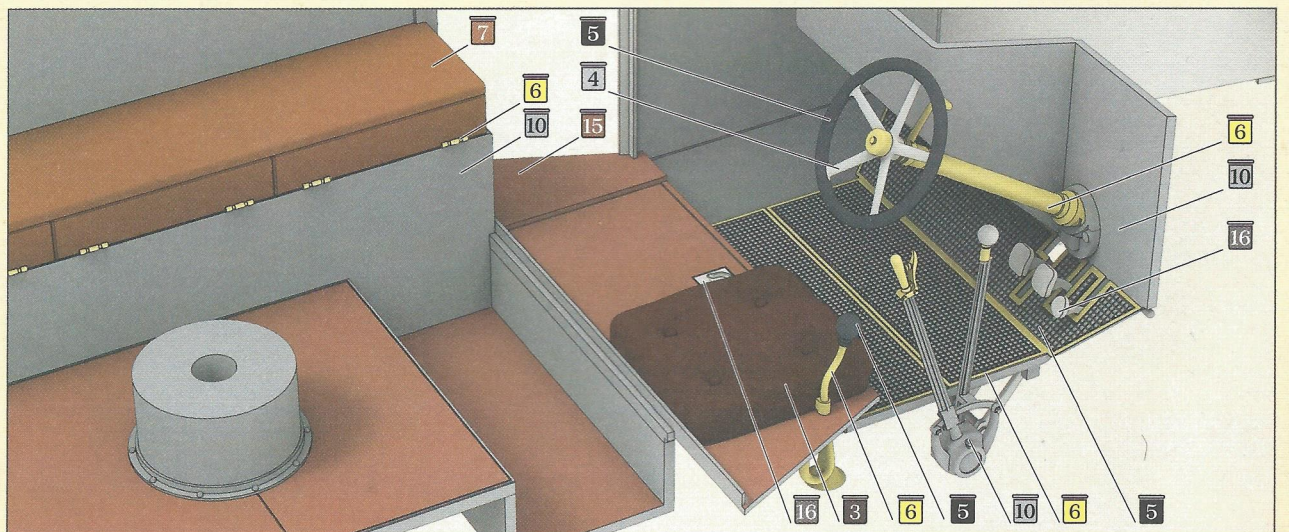

Fig. 13. Interior colours

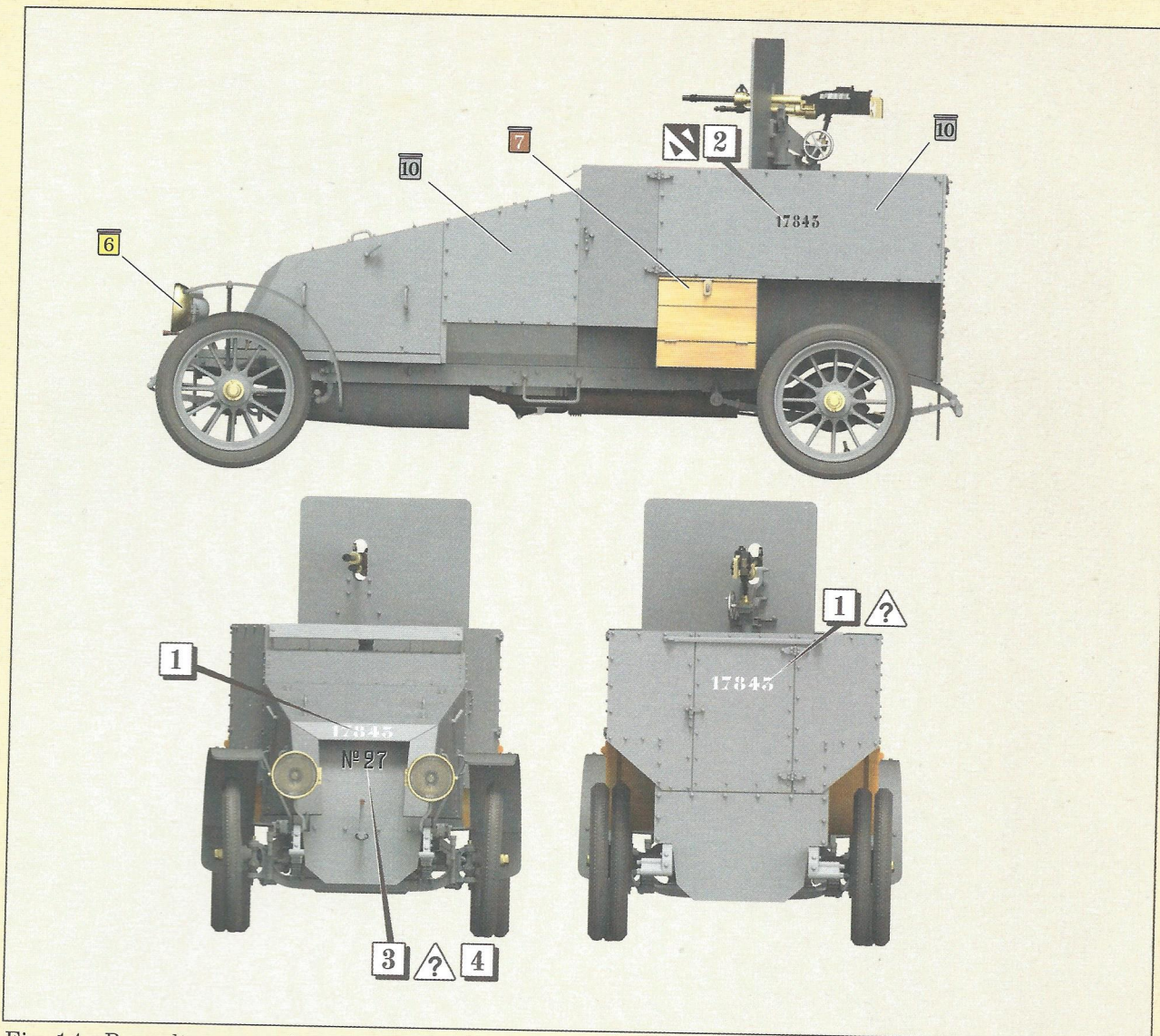

Fig. 14. Renault armoured car 17843
Somewhere in Champagne, 1915

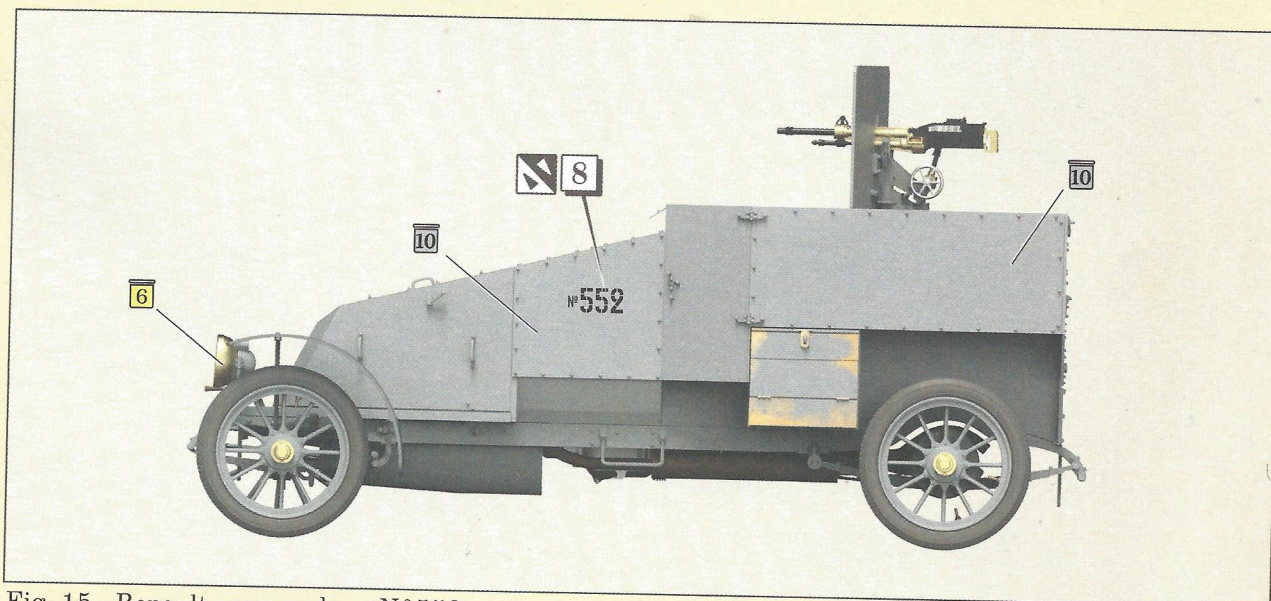

Fig. 15. Renault armoured car N° 552
Summer 1915, Creil

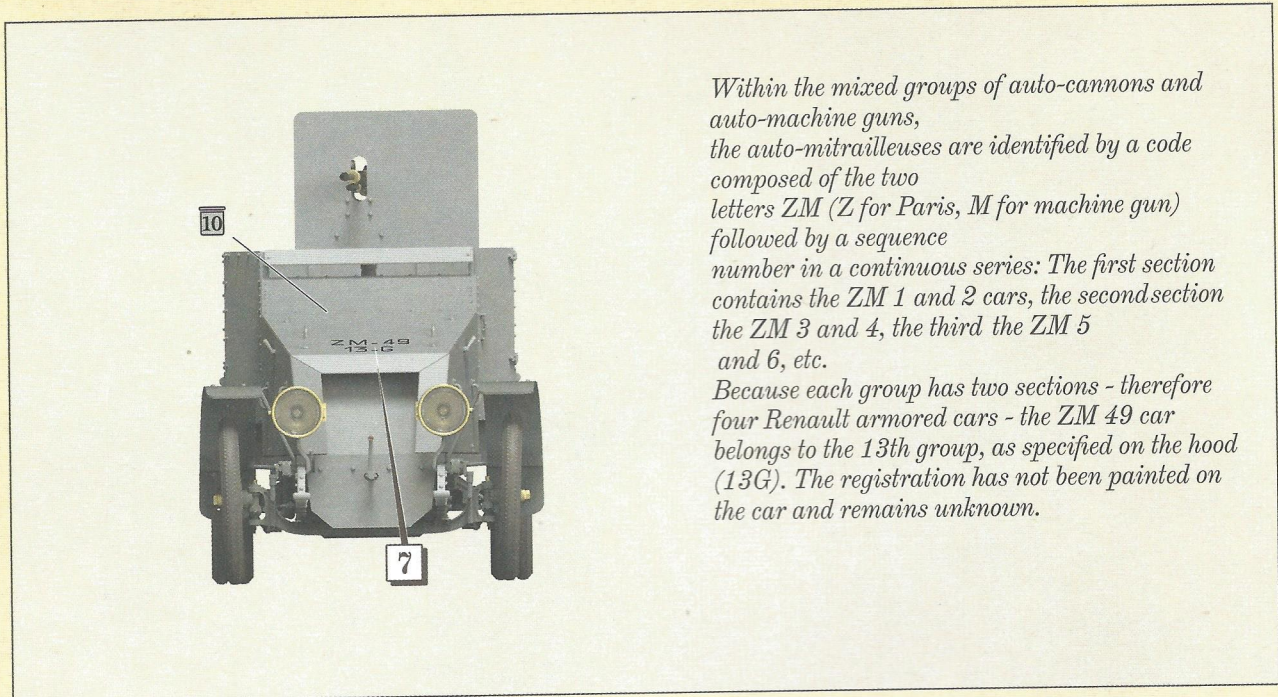

Fig. 16. Renault armoured car from the 13th group. 1915

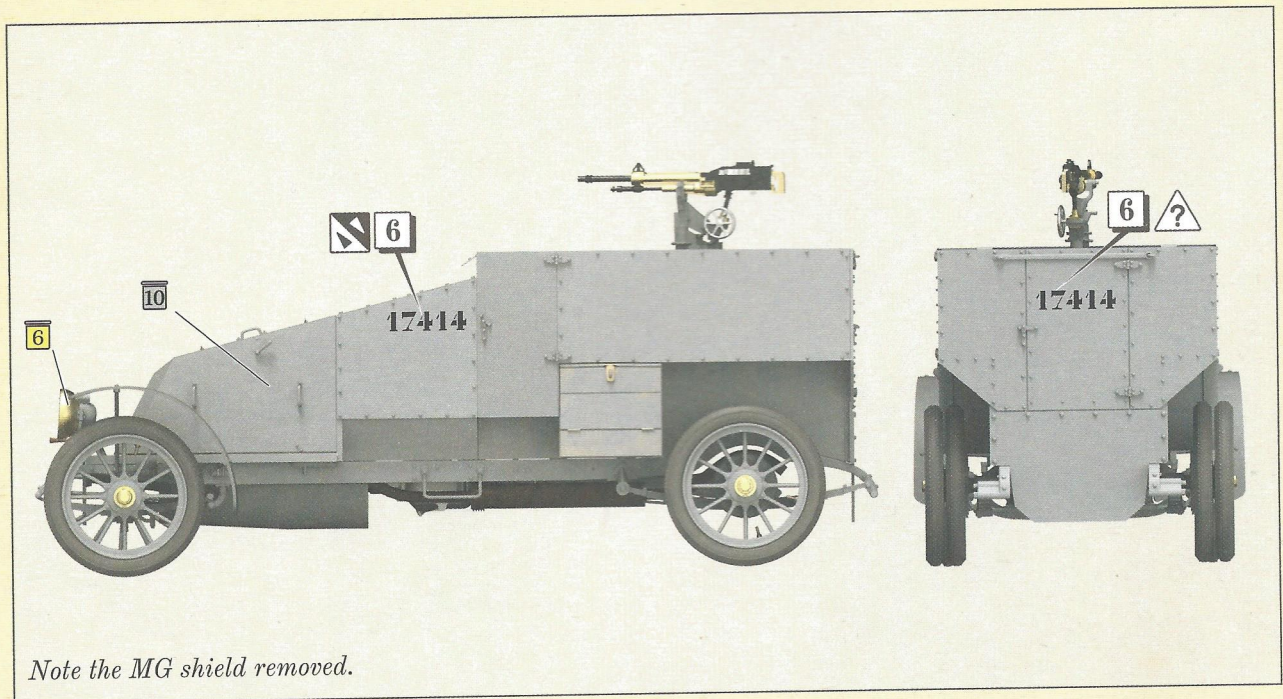
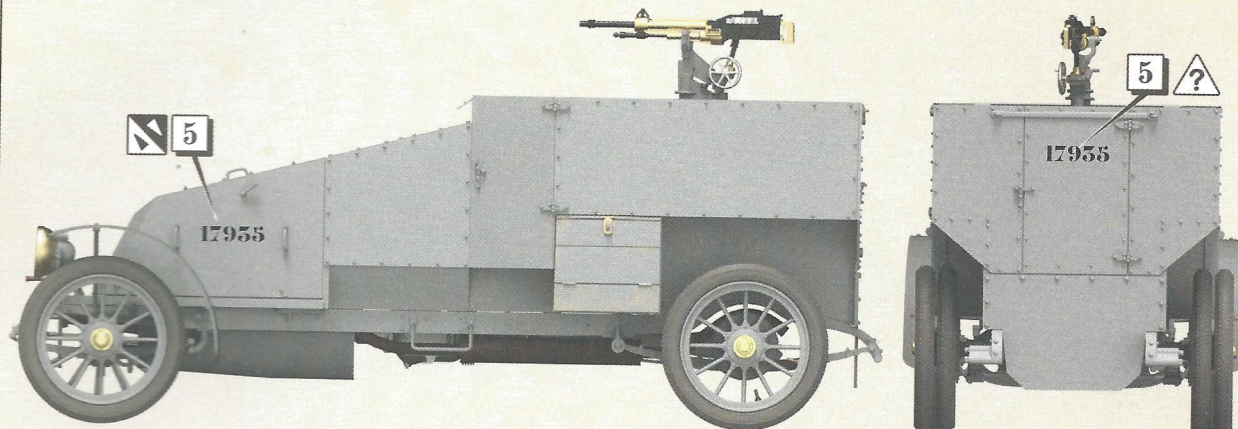

Fig. 17. Renault armoured car from unknown group. 1915

Here we have, in comparison with profile page 19, an illustration of the inconsistent way in which the registration number was painted on the cars



Note the MG shield removed.

Fig. 18. Renault armoured car from unknown group. 1915

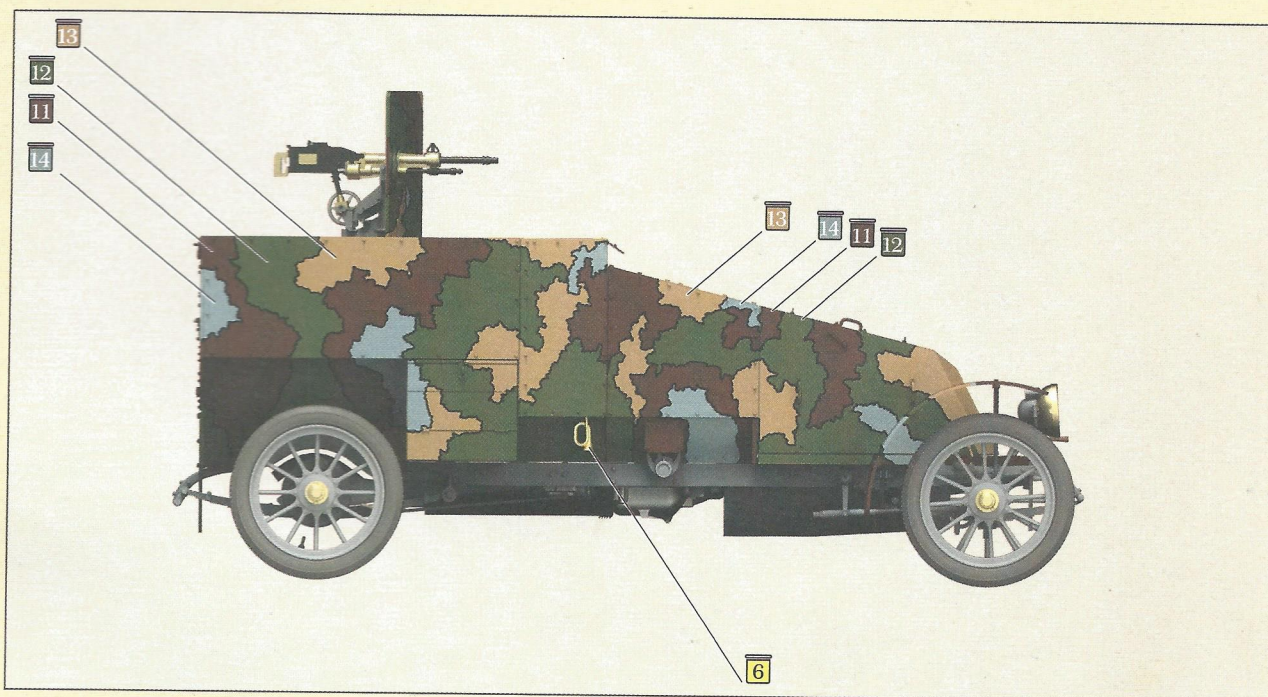

Fig. 19. Renault armoured car from the 10th group (probably).
Spring of 1915.

CSM team would like to thank:

Oleg Zaichkin - Russia
Jean-Louis Durand - France
Francois Vauvillier - France
Brandon Darnell - USA
Boris Harlamov - Russia

for all your help in this project

