

1 Chinook HC.1; 240 OCU, RAF, operating in Saudi Arabia during "DESERT STORM"; February 1991.

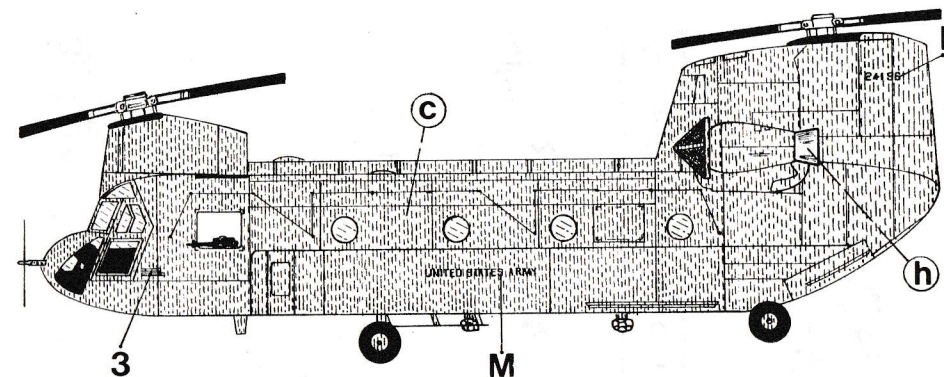

3 CH-47D Chinook; 101st Airborne Division, U.S. Army. Deployed to Saudi Arabia for Operation "DESERT STORM"; February 1991.

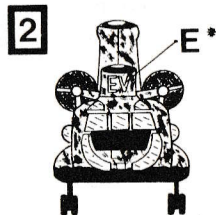
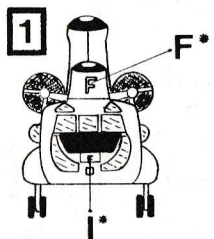

Reference for **2**:
JET & PROP 4/91

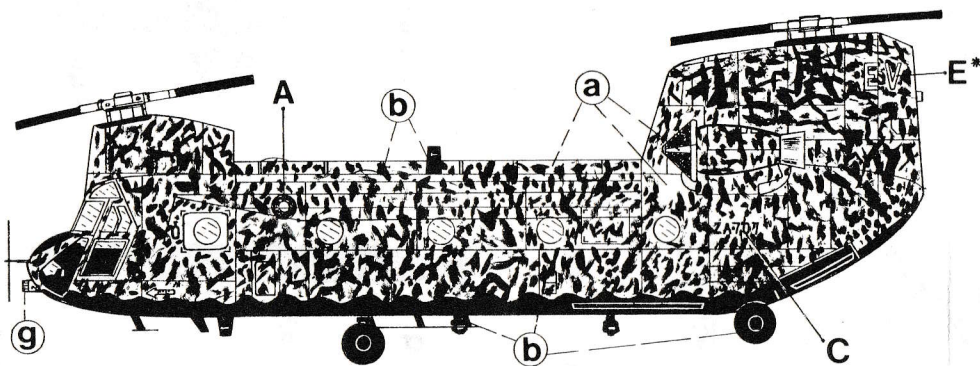

2 Chinook HC.1; 7th Sqn RAF, Saudi Arabia, with toned-down camouflage for night operations during "DESERT STORM"; February 1991.

72-012

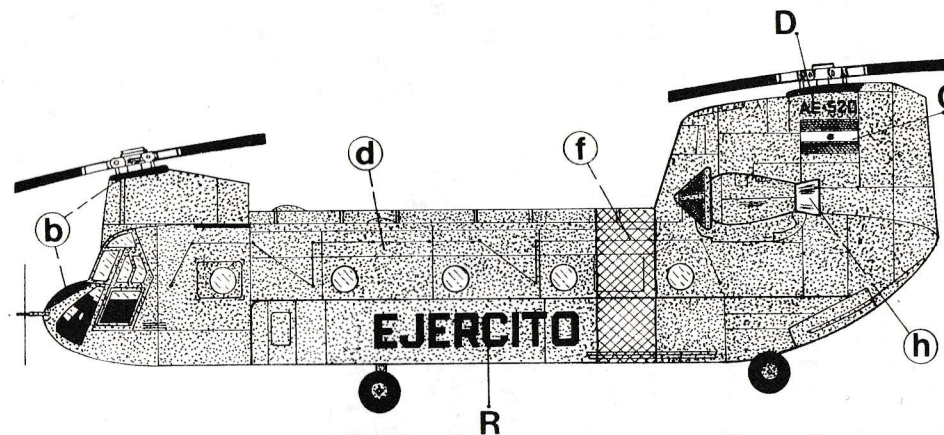

4 CH-47C Chinook; 601st Aviation Battalion, Argentine Army, during the South Atlantic War. Falkland Islands, June 1982.

*Markings applied after the Gulf War.

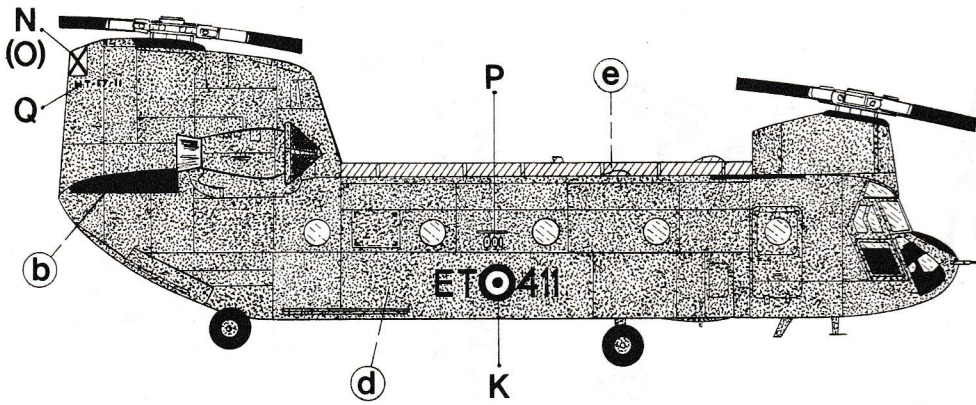

All versions:

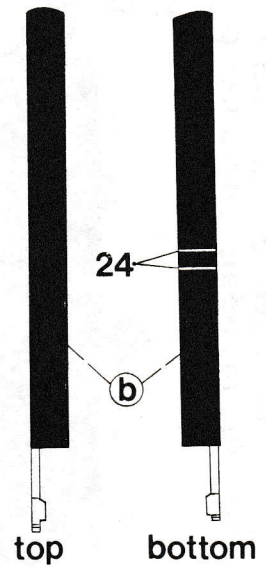

5 CH-47D Chinook; Helicopter Unit 5, Spanish Army Air Corp; Los Remedios A.B., 1987

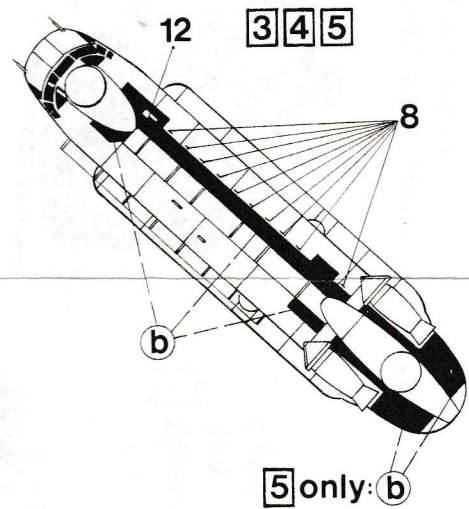
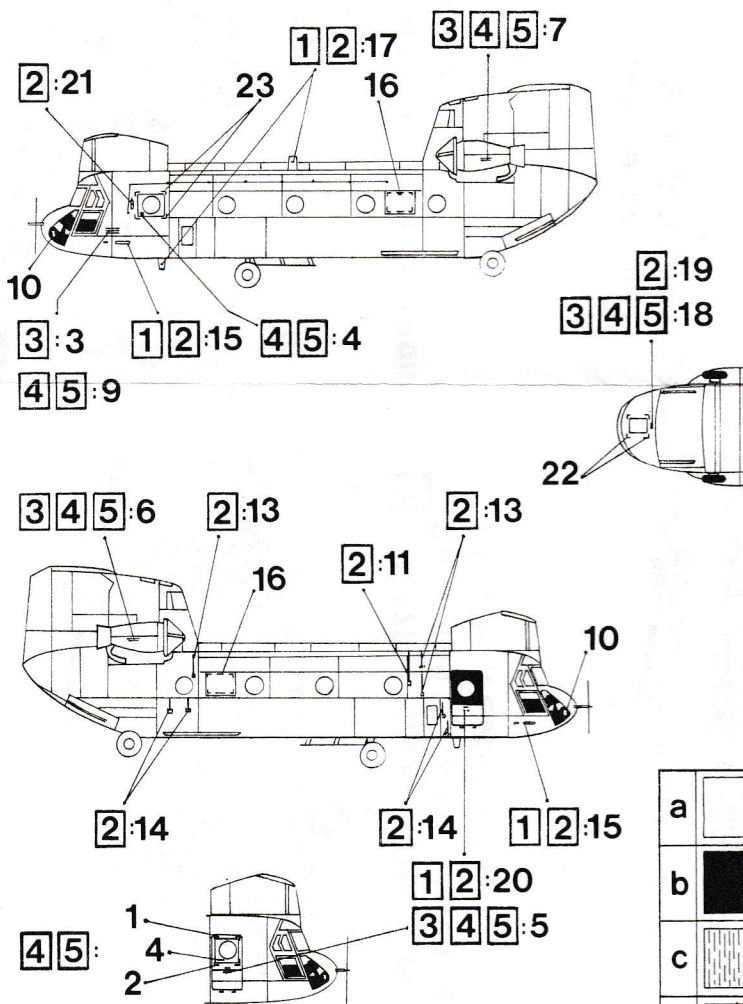

Model kit produced by Matchbox

BOEING – VERTOL Chinook CH-47D/HC.1

72-012

		Humbrol	Revell
a	Desert Pink F.S.30279	121, 95% 60+ 5%	—
b	Black F.S.37038	33	8
c	Dark Green F.S.34031	108	46
d	Olive Drab F.S.34087	155	—
e	White	34	5
f	Lemon Yellow	99	12
g	Dark Grey	79	77
h	Steel	Metal- cote	91