

1/35 Russian Artillery Tractor Komsomoletz T-20 Early Assembly Guide

this kits offer option to build either T20 Mod.1937 or T20 Mod.1938 Early

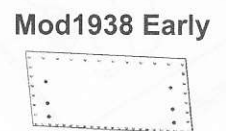

remove 2 lines of rivets
for Mod.1938 Early

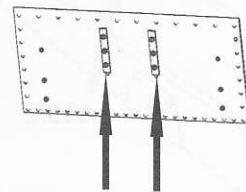
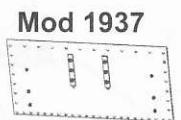
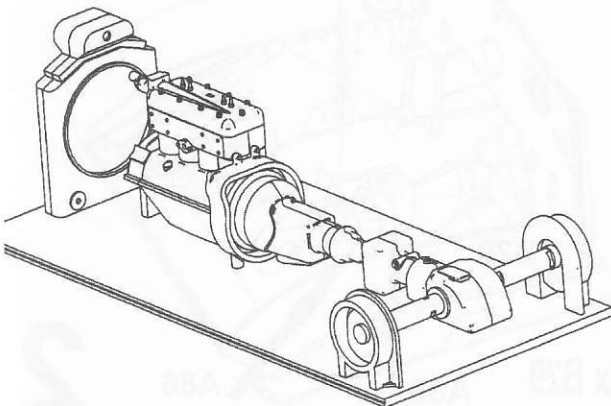
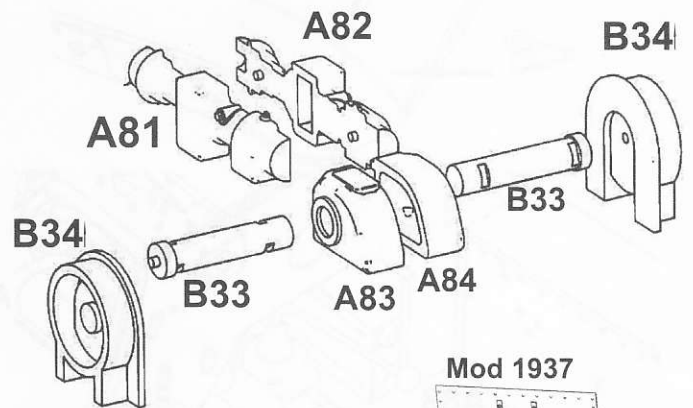
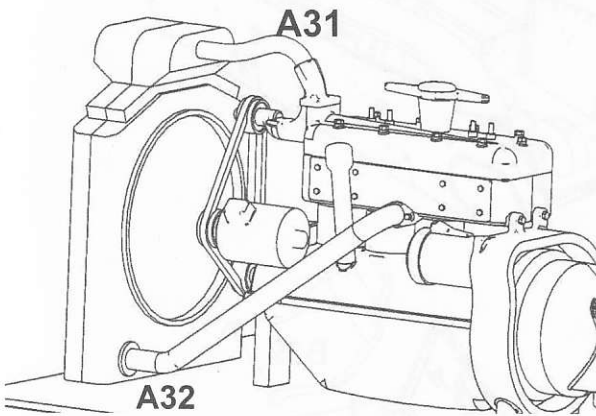
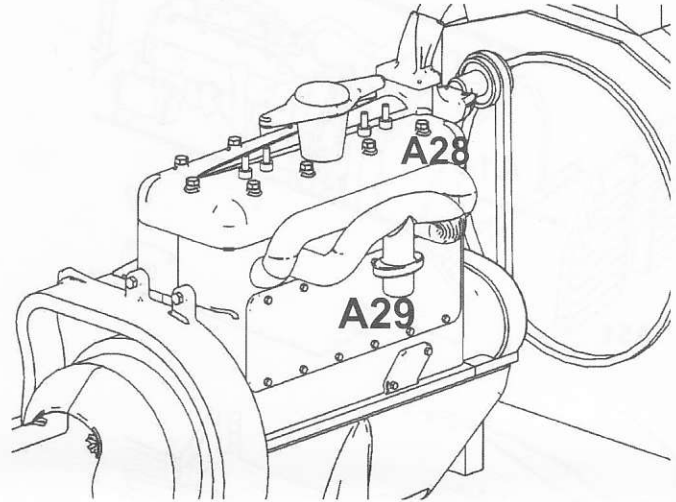
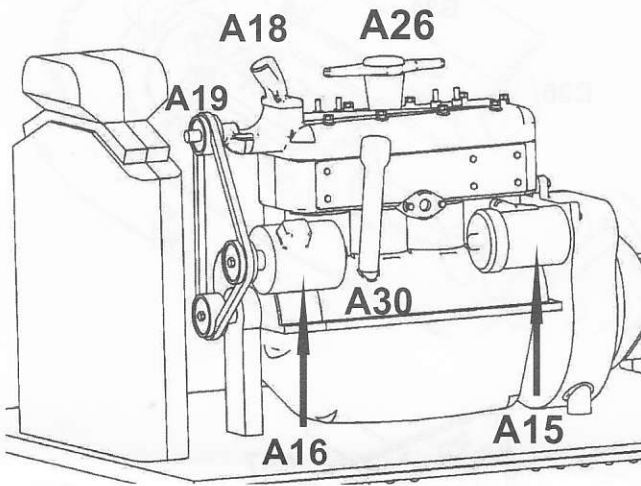
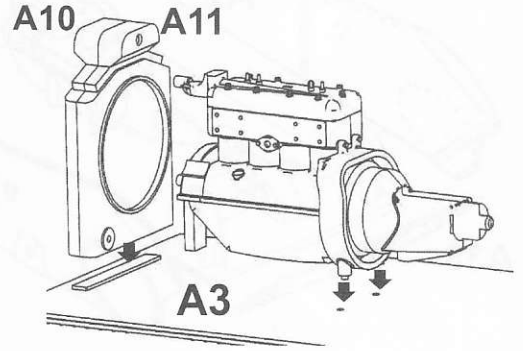
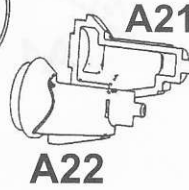
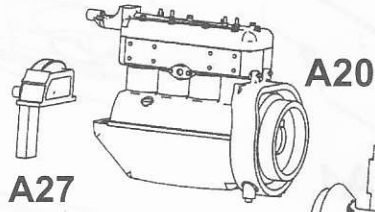
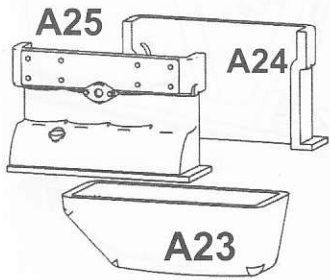
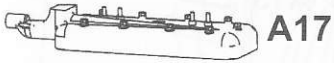
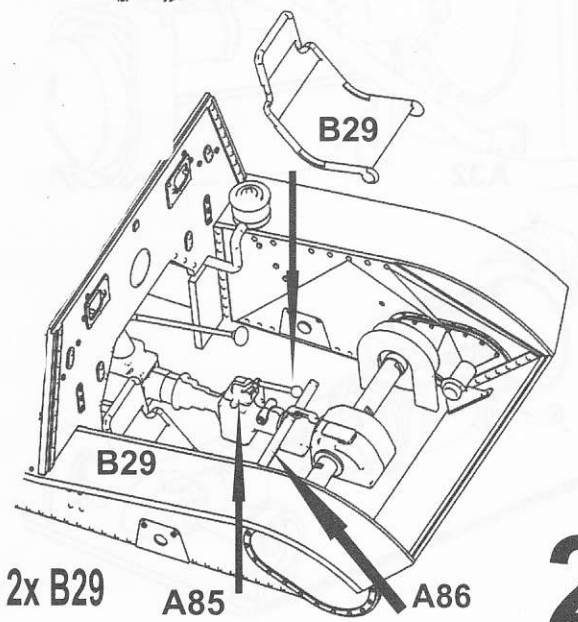
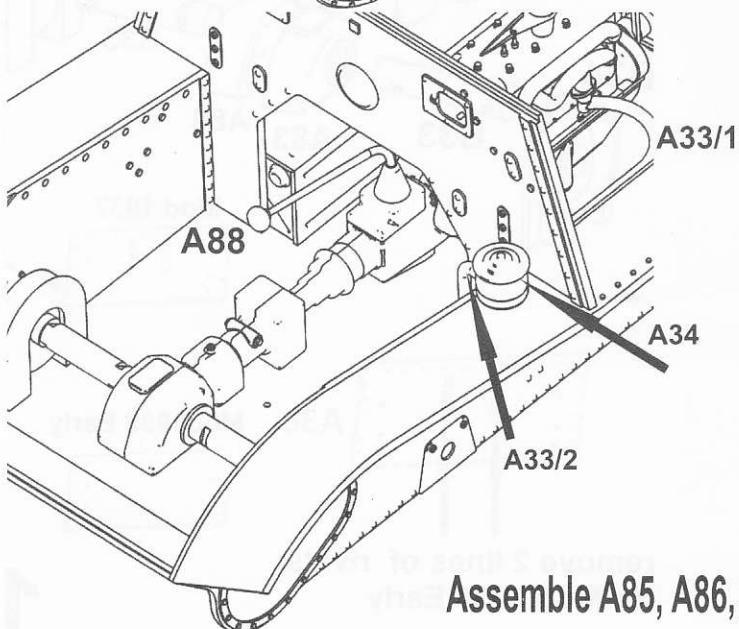
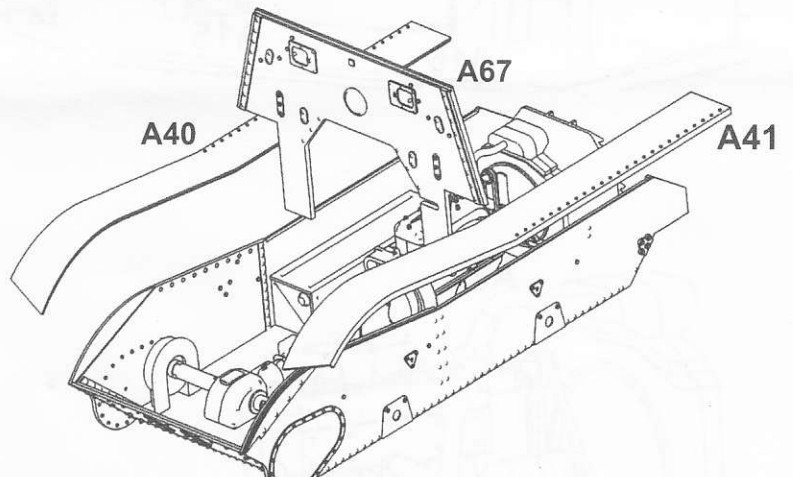
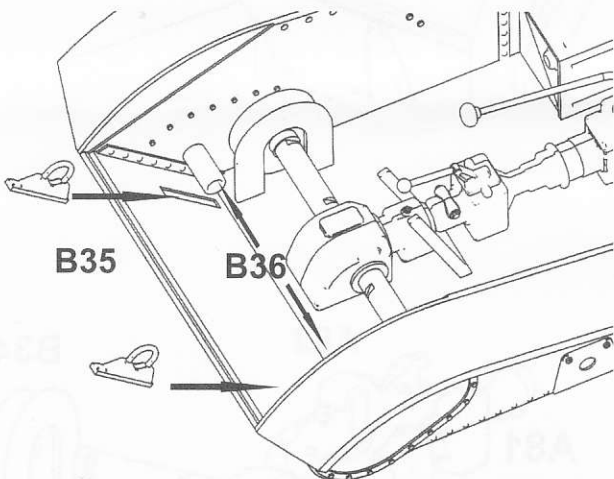
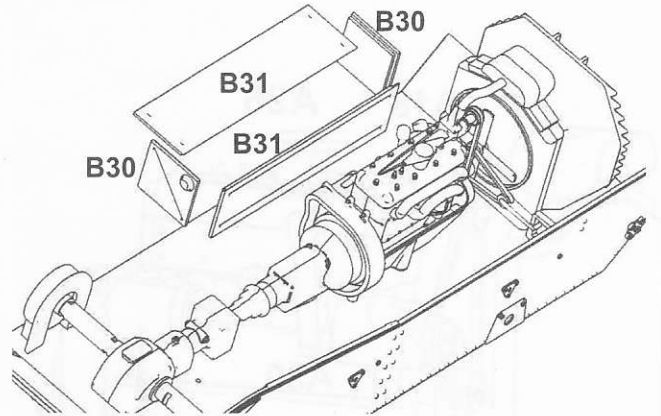
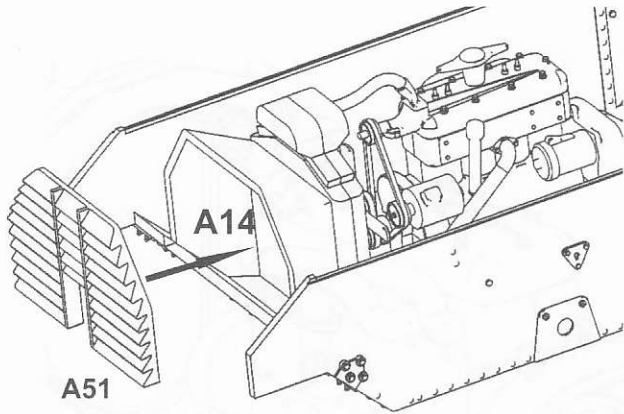
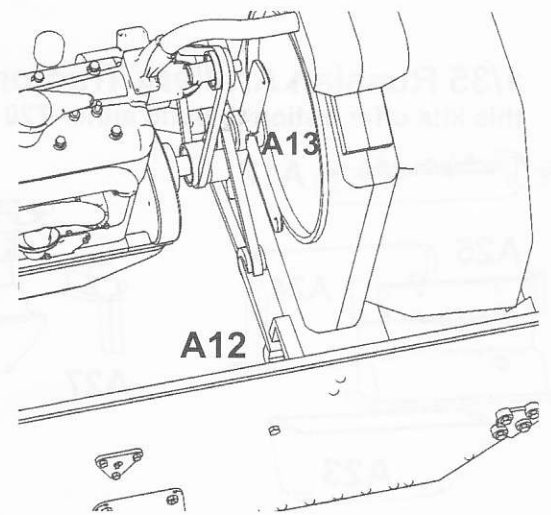
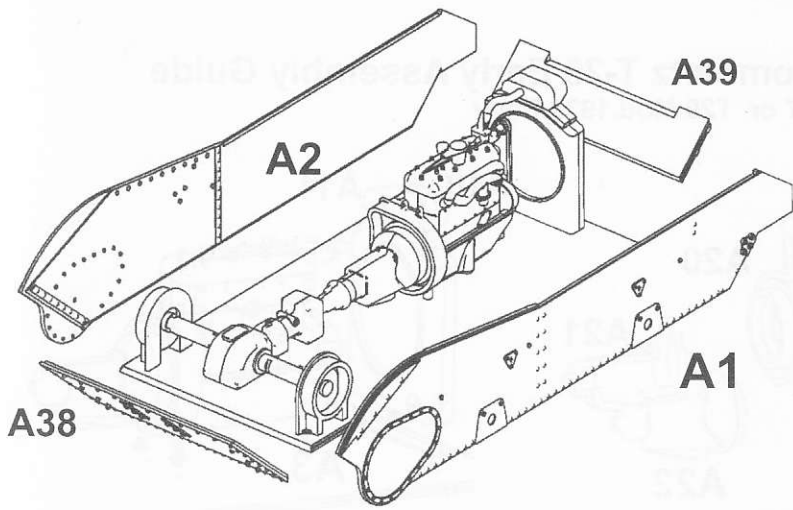

Assemble A85, A86, then 2x B29

Engine covers A4+A5 and A6+A7 can be assembled either open or closed

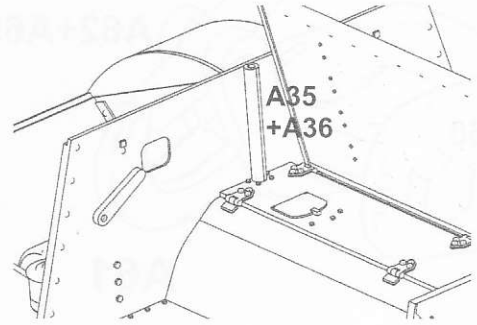
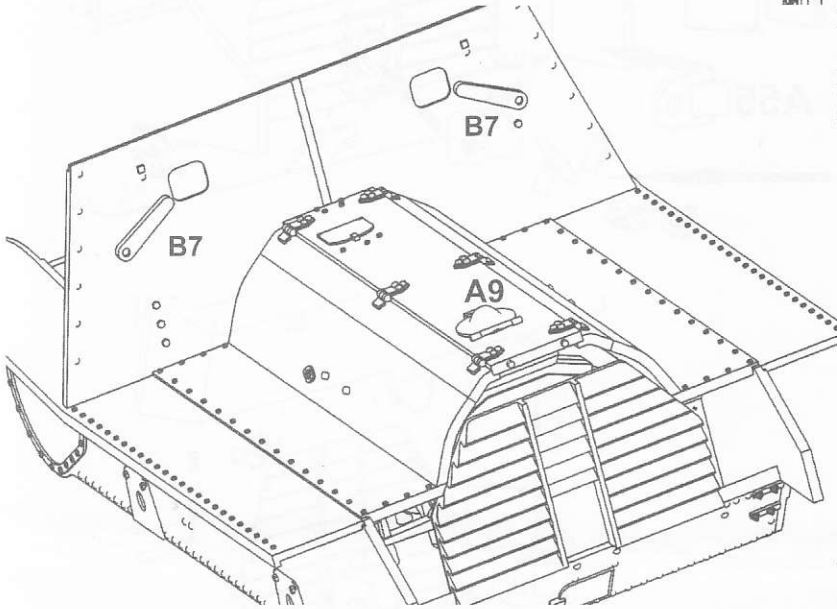
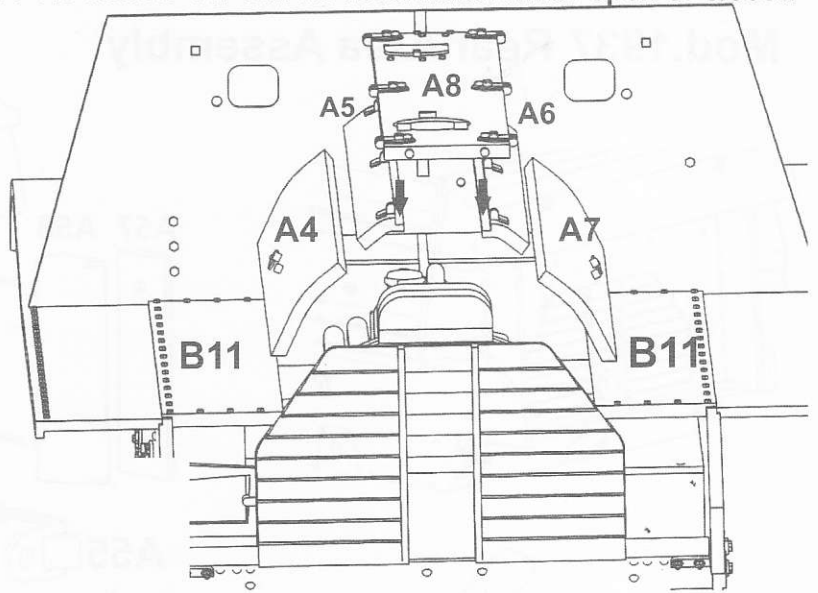
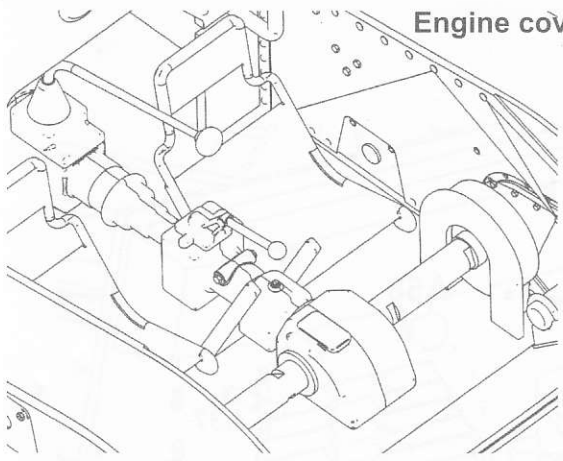

Benches can be rotated into any position required

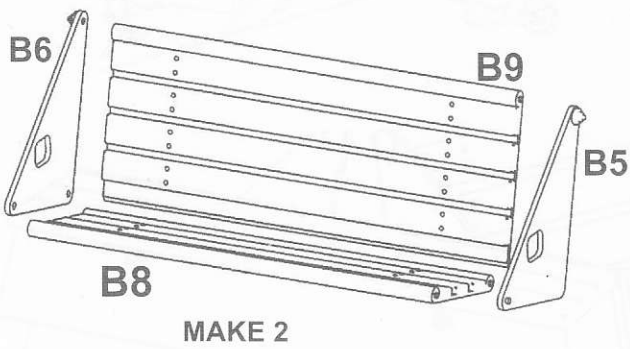

MAKE 2

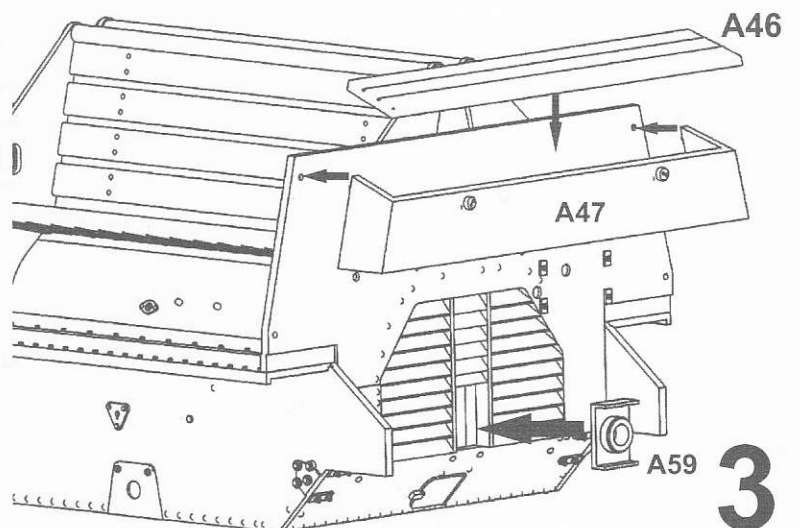
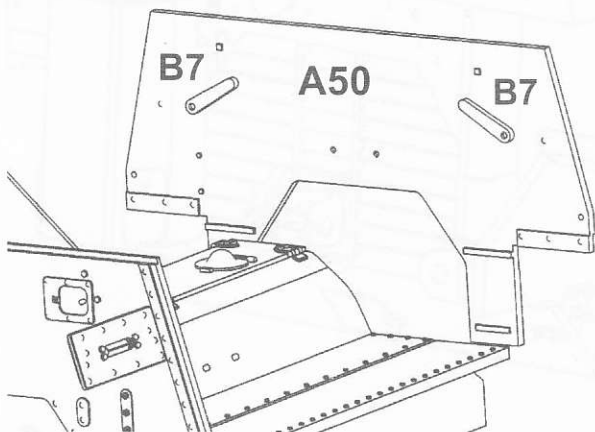
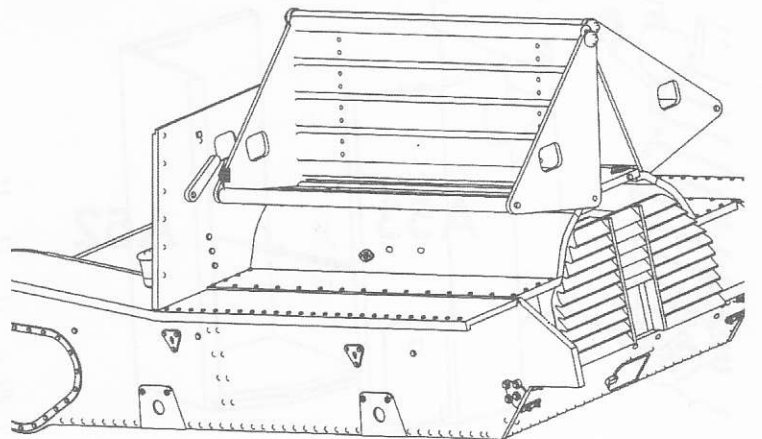

Mod.1937 Rear Area Assembly

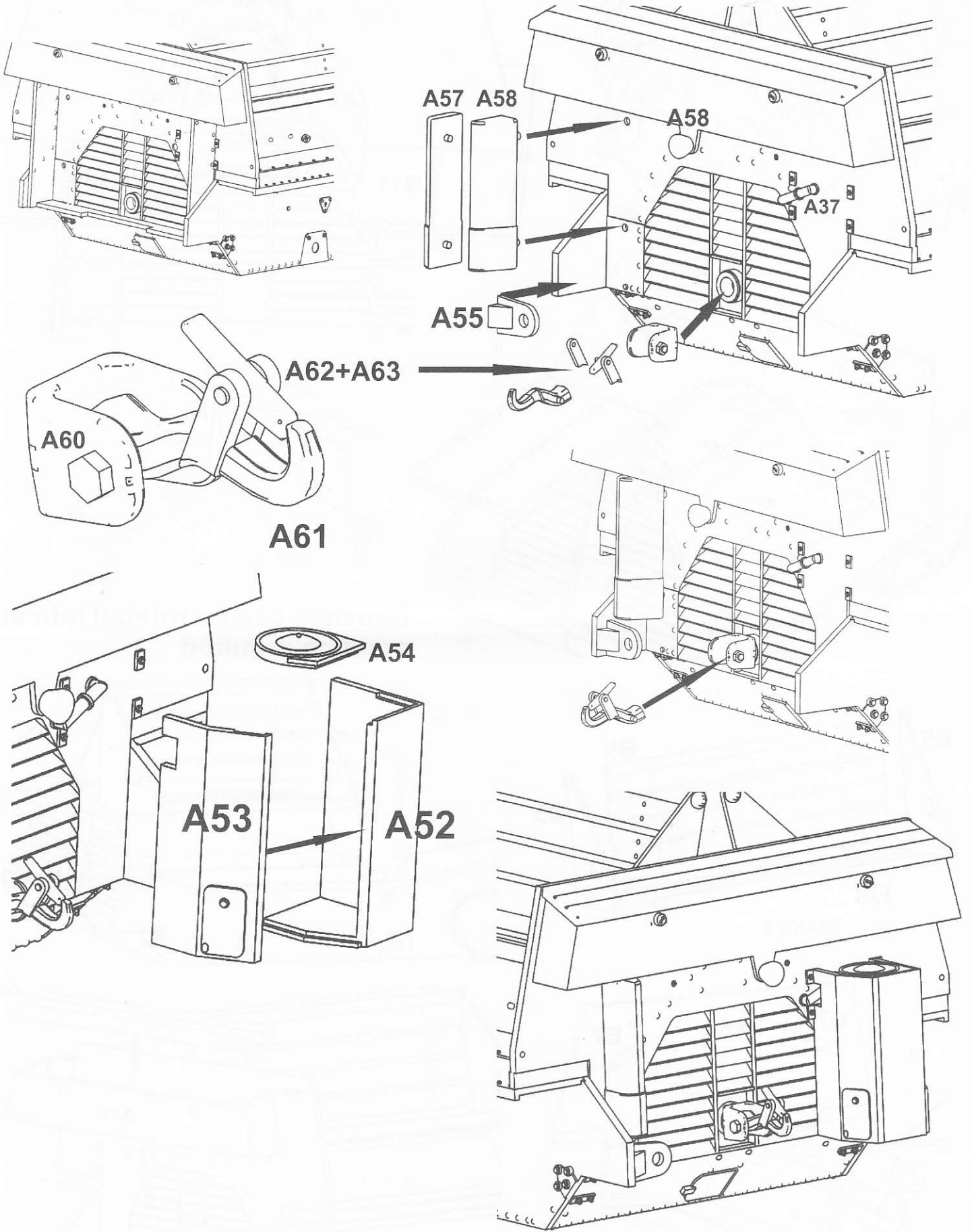

Mod.1938 Early Rear Area Assembly

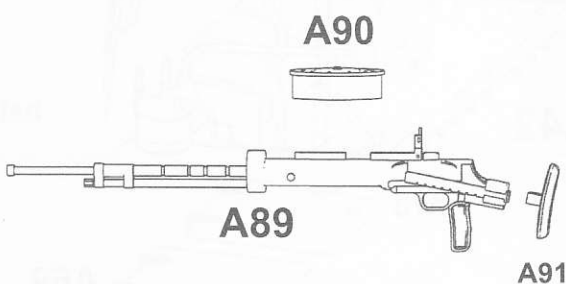
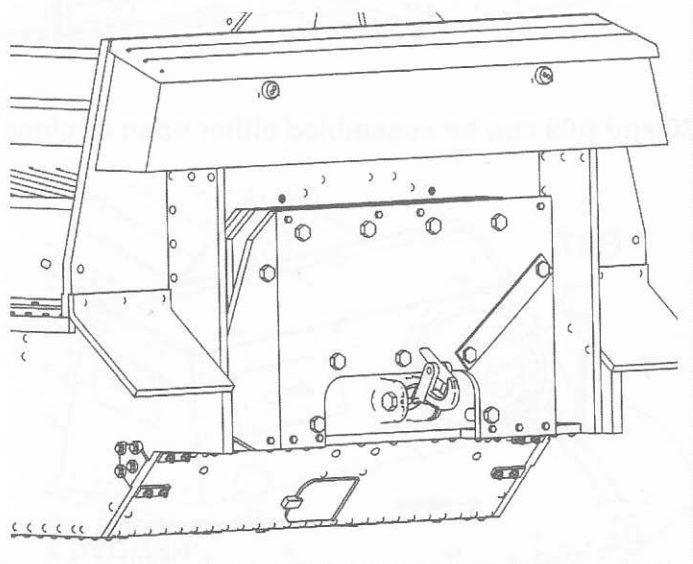
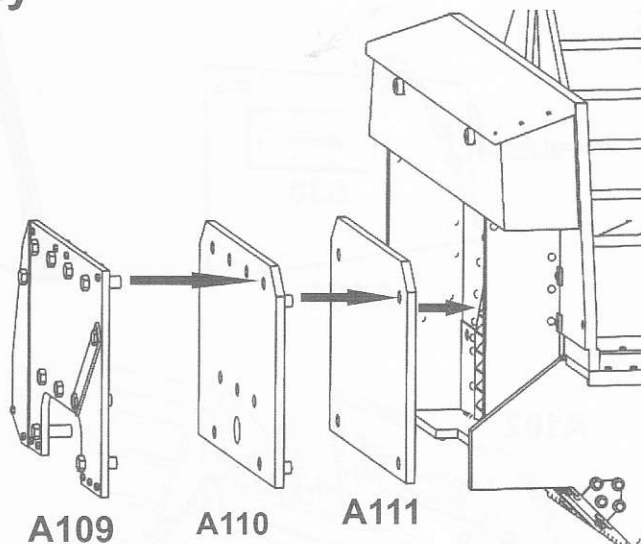
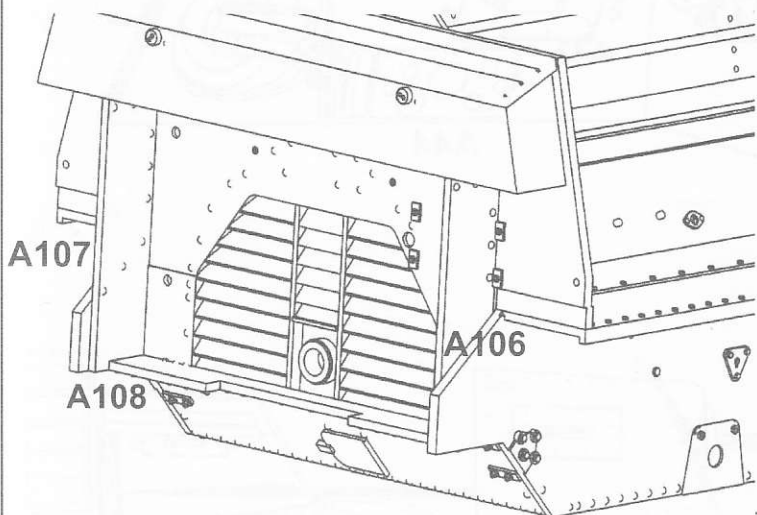

INNER SHUTTERS B28 CAN BE ASSEMBLED EITHER OPEN OR CLOSED

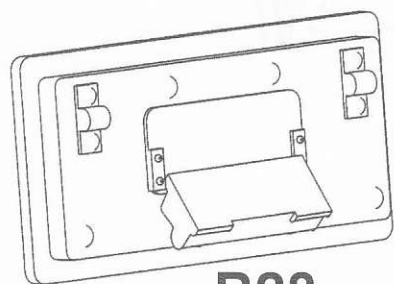

B28

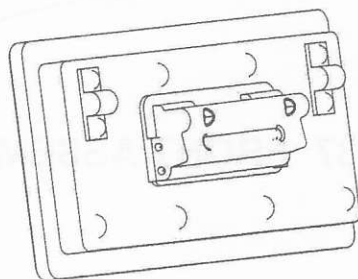

MAIN SHUTTERS CAN BE ALSO ASSEMBLED CLOSED IN ANY OPEN POSITION - SET B32 ACCORDINGLY

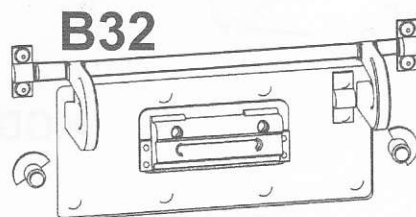

Mod.1938 Early Front Assembly

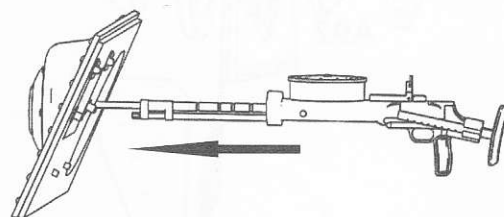
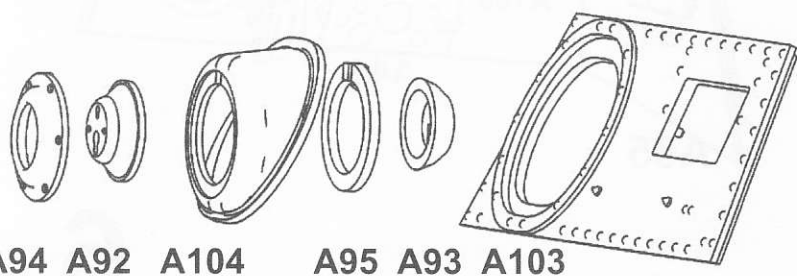

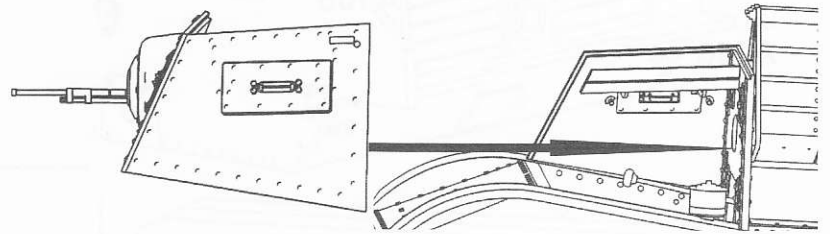
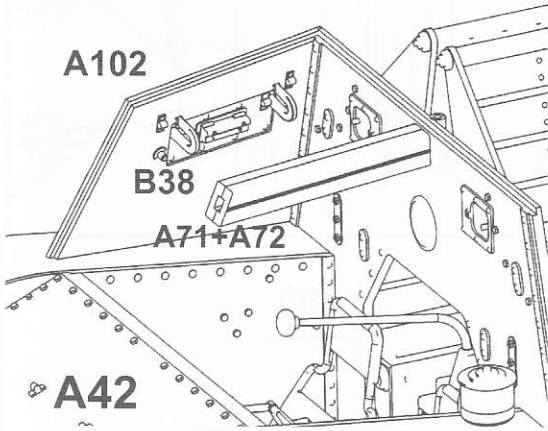
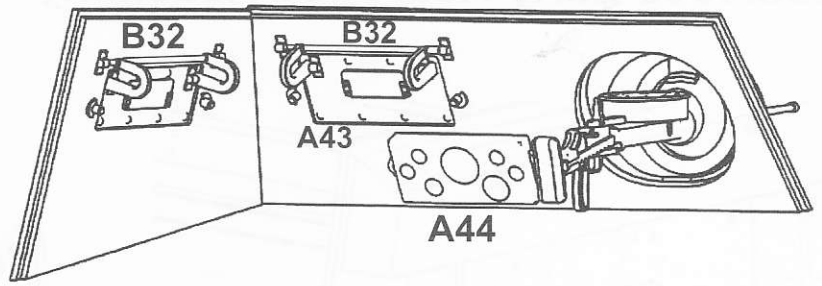
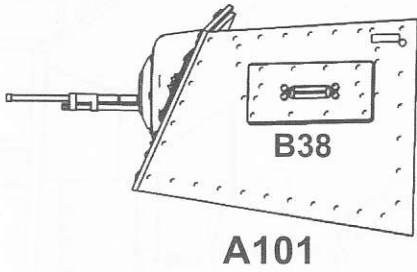

hatches A70 and A69 can be assembled either open or closed

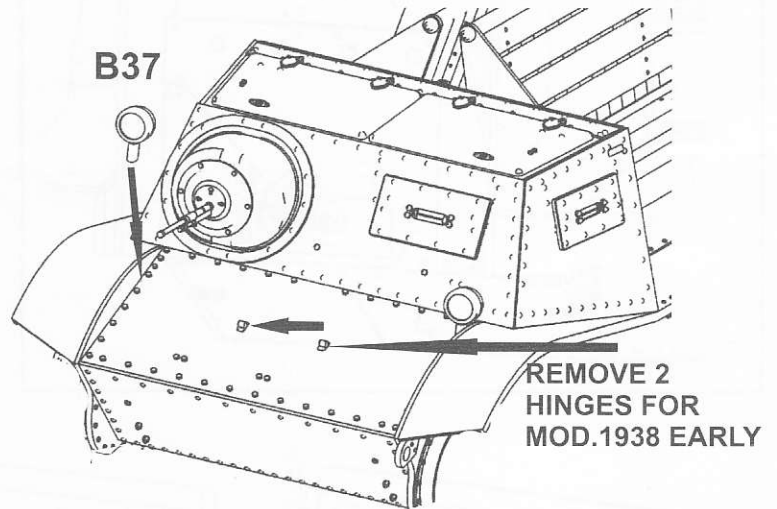
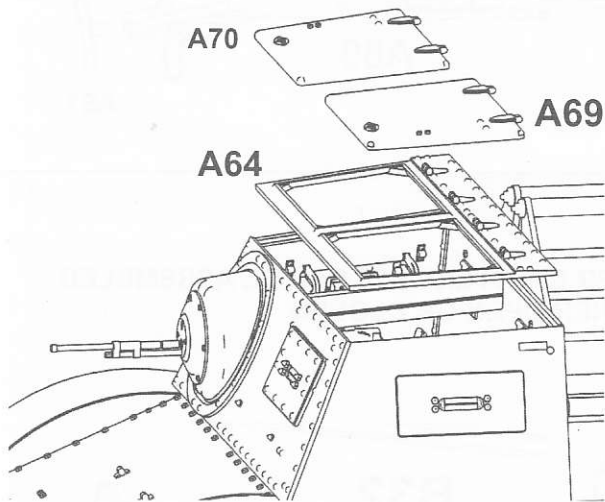

MOD.1937 FRONT ASSEMBLY

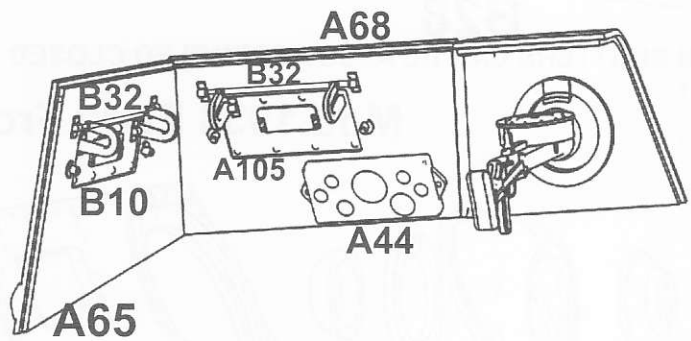
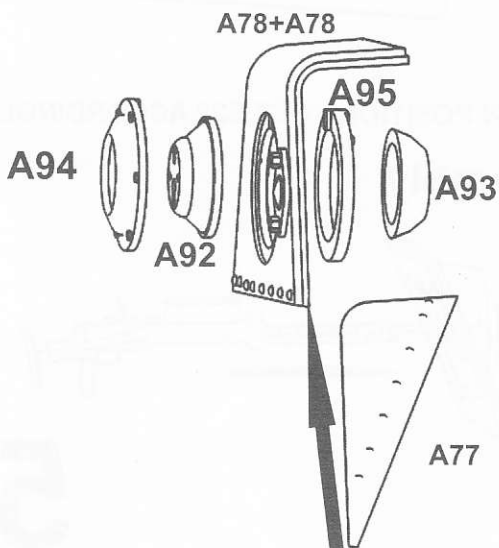

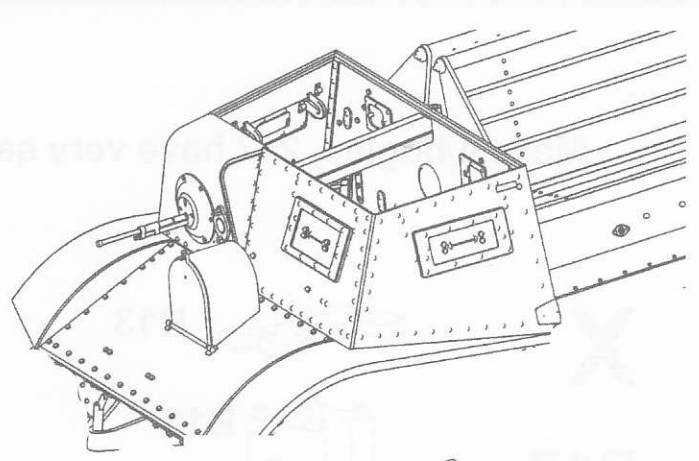
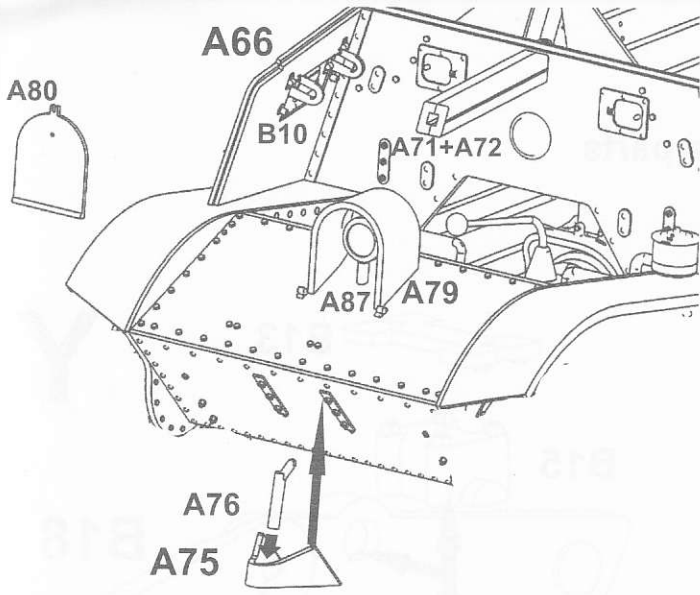

Parts A79 and A80 are optional, this light cover seems to be Finish modification. Tractors documented in Russian or captured in German service are assembled with two lights placed just like for Mod.1938 Early

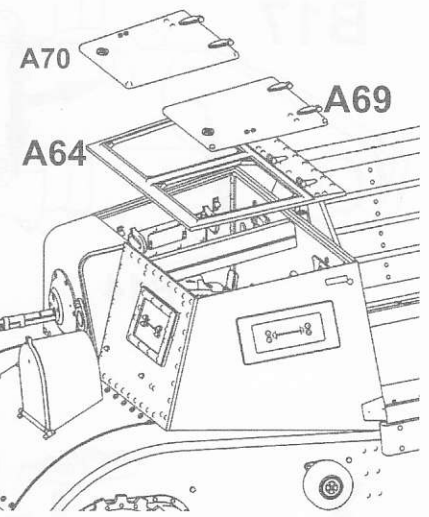

REST OF ASSEMBLY IS THE SAME FOR BOTH VARIANTS

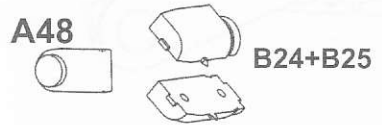
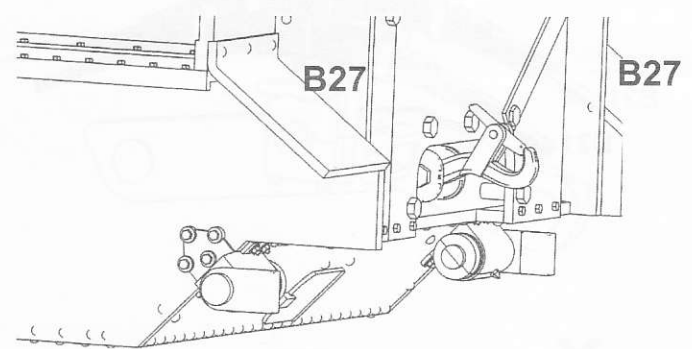
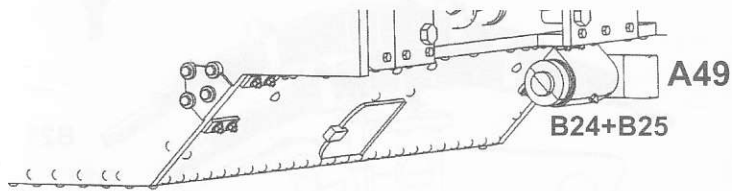

Idler wheels

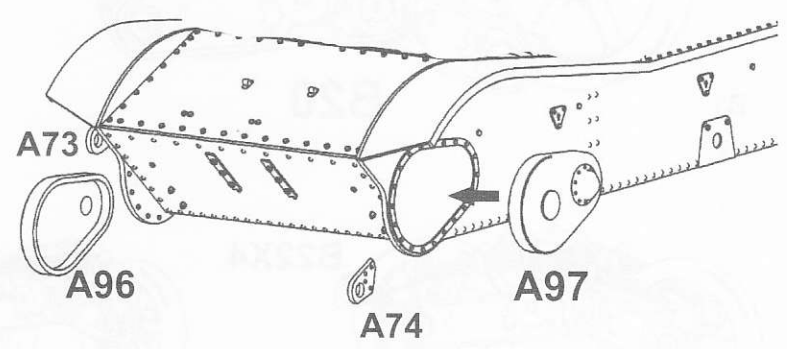
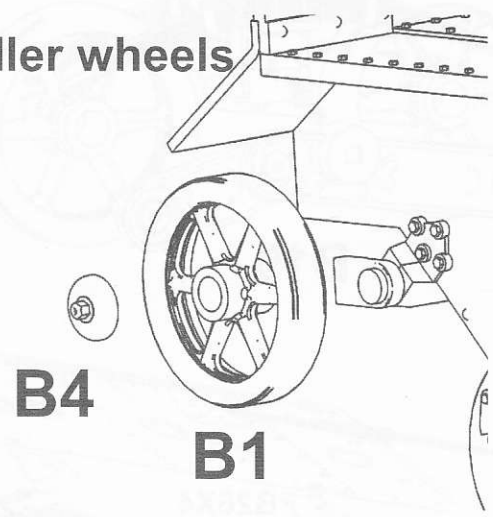

Make 4 bogies, 2+2 have very same parts

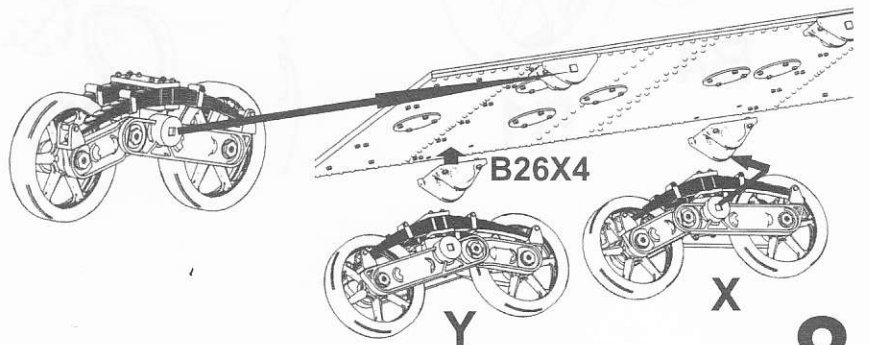
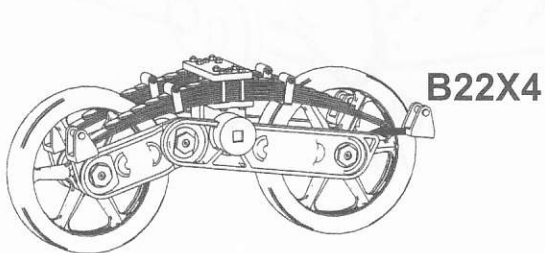
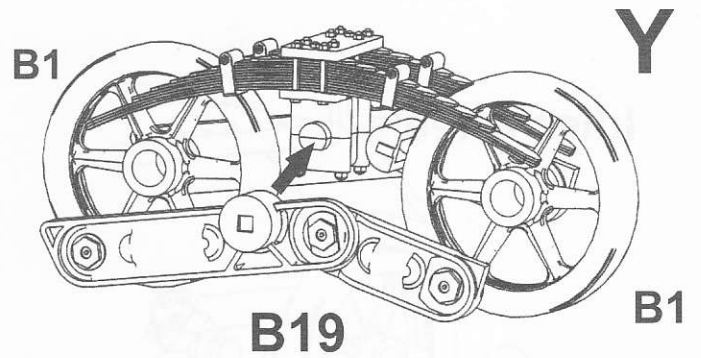
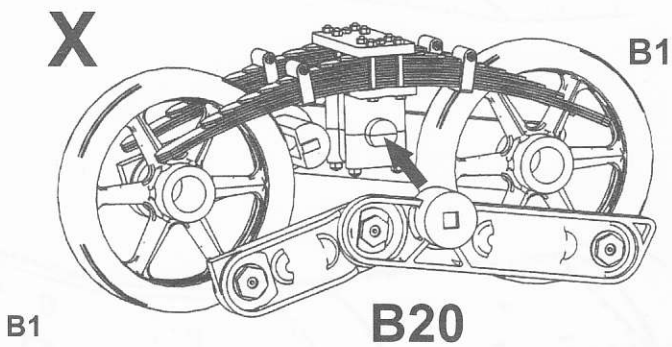
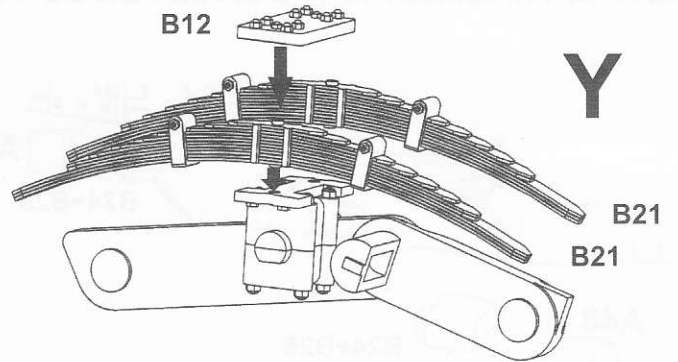
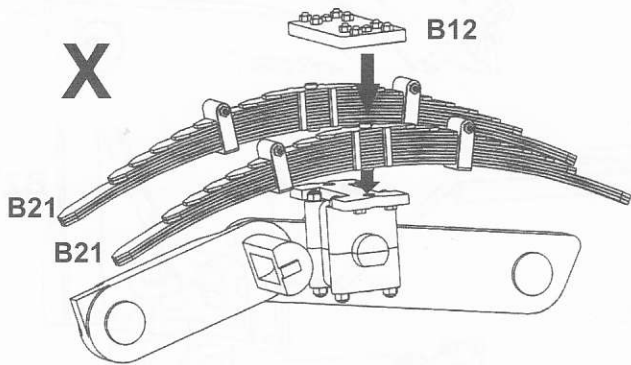
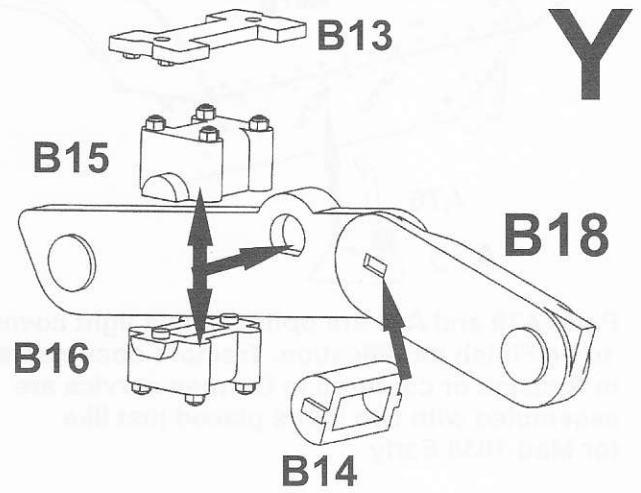
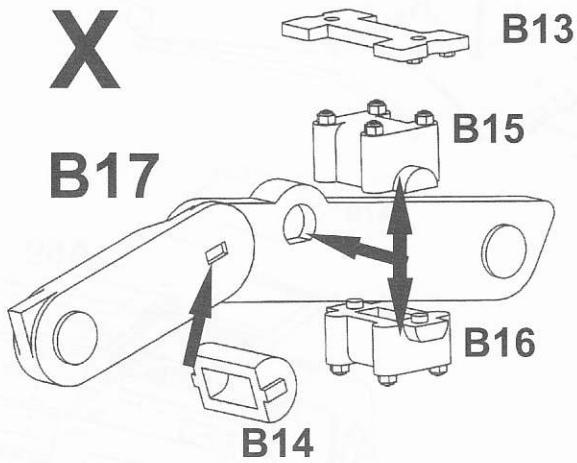

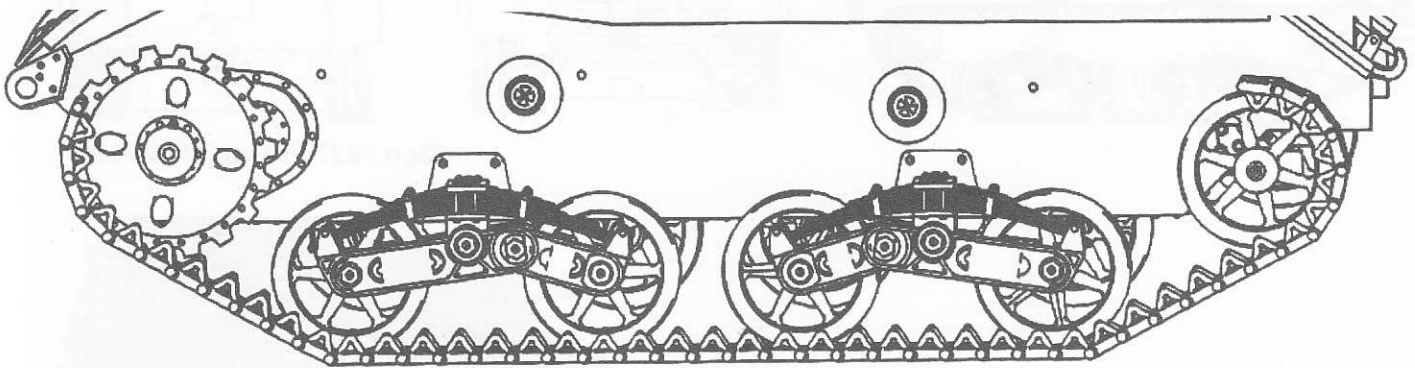
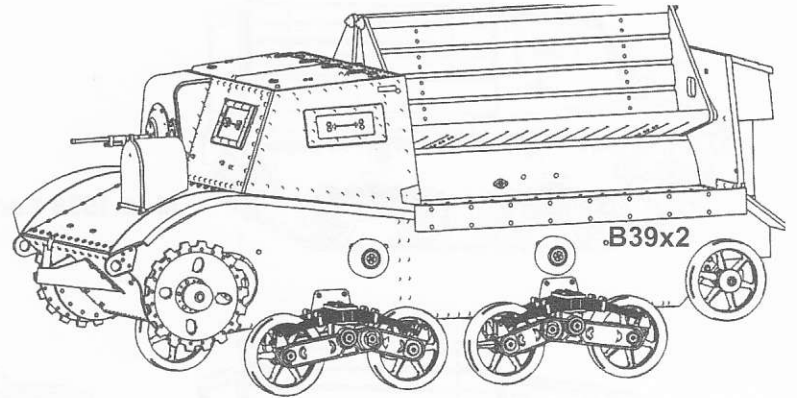
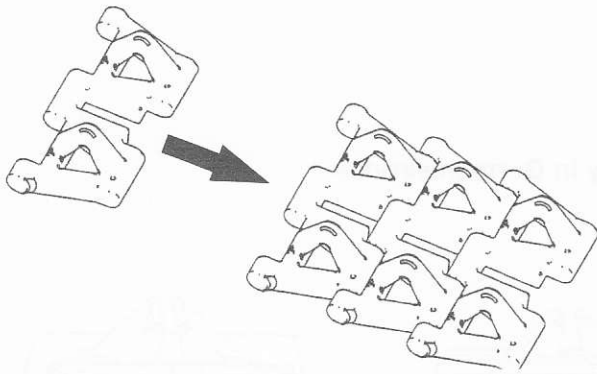
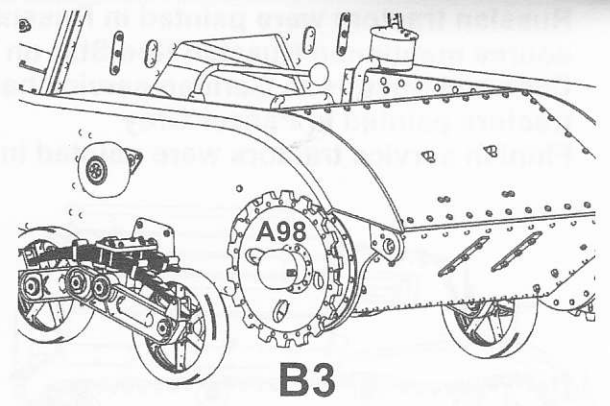
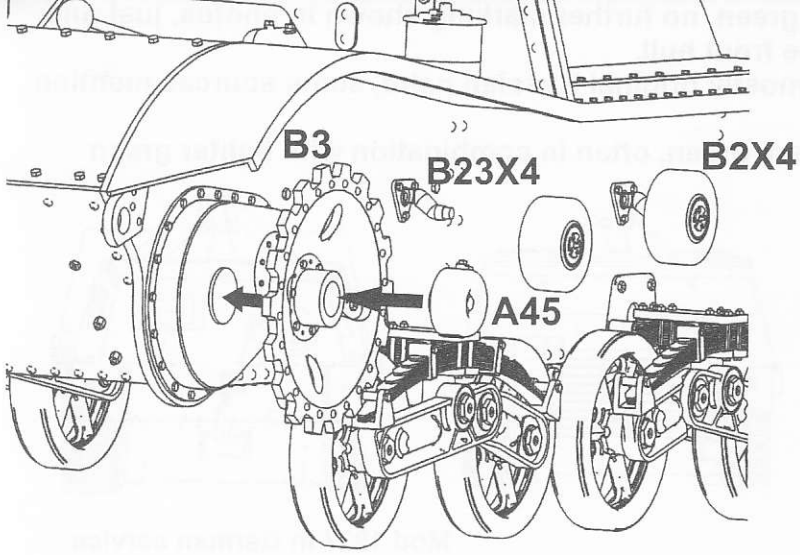

Track assembly, 78 links per track, tractors had trouble with falling tracks often, some references mentioned that a tracks were sometimes shortened to 77 links to improve this issue

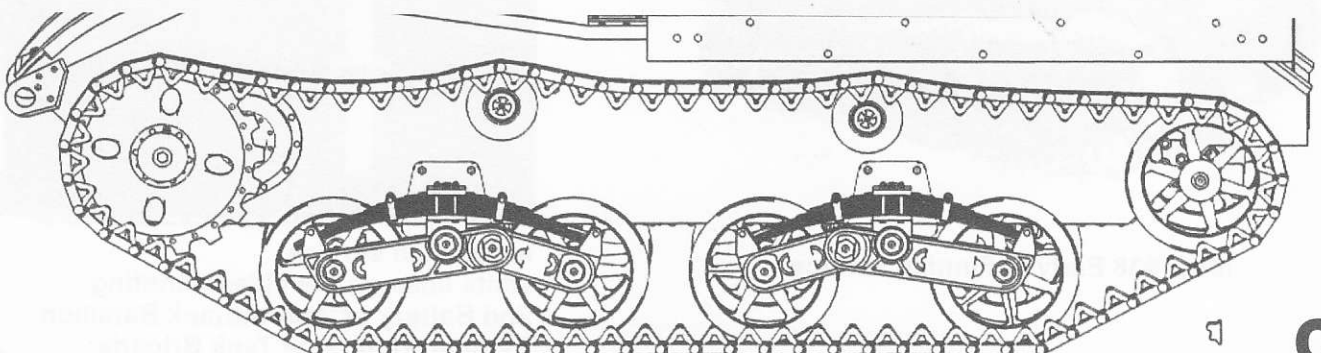

Russian tractors were painted in Russian green, no further marking shown in photos, just one source mentioned Russian Red Star on the front hull.

Captured tractors in German service had mostly original Russian paint, some sources mention tractors painted in Panzer Grey

Finnish service tractors were painted in dark green, often in combination with lighter green

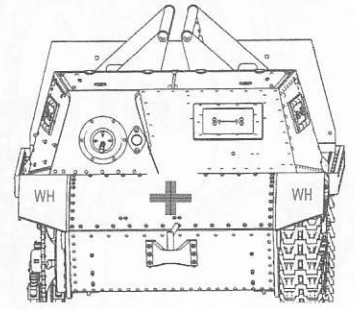
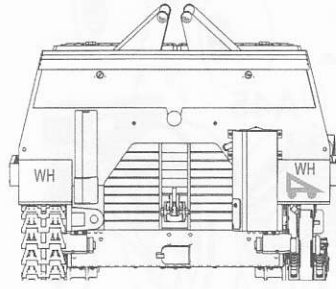
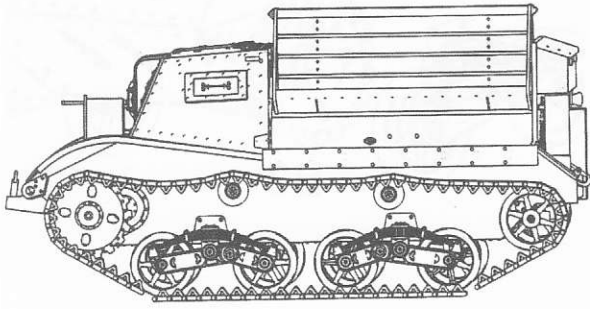

Mod.1937 in German service

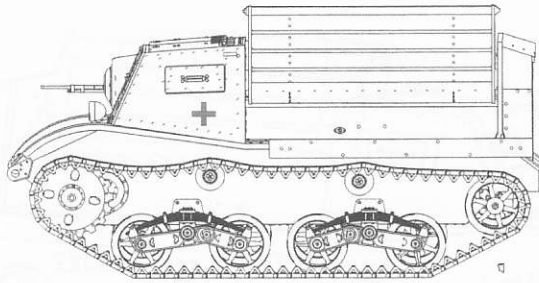

Mod.1938 Early in German service

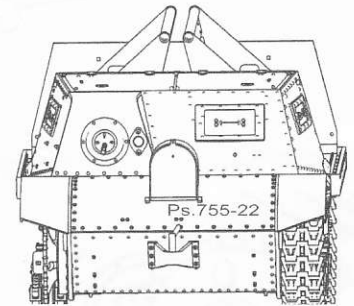
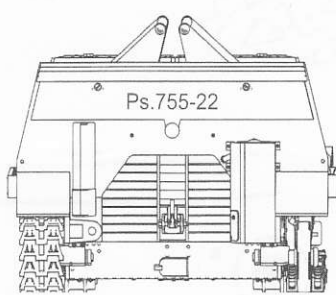
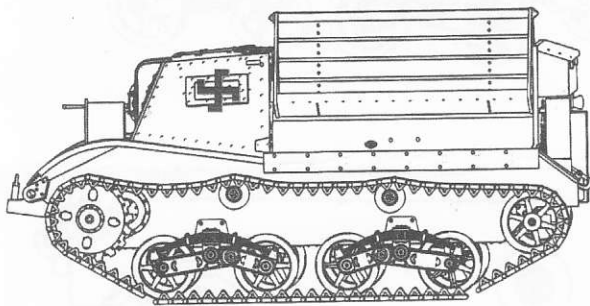

Mod.1937 in Finnish service



Mod1938 Early in Finnish service

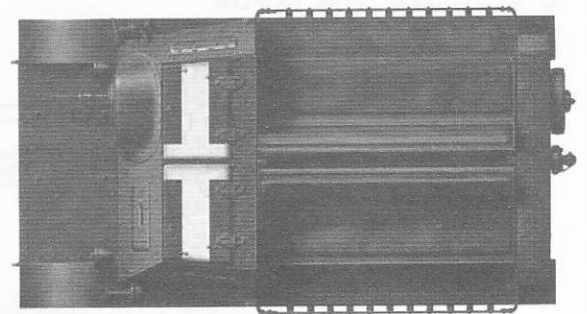
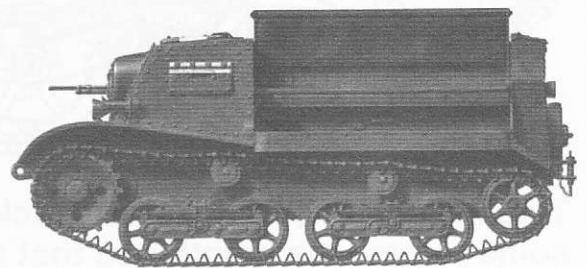

In Russian service
white lines on the sides denoting
2nd Battery of 2nd Antitank Battalion
Estonia, 18th Light Tank Brigade
white cross on the roof to identify
tractor from the air

1/35 Russian Fuel Trailer 1 Axle Assembly Guide

1

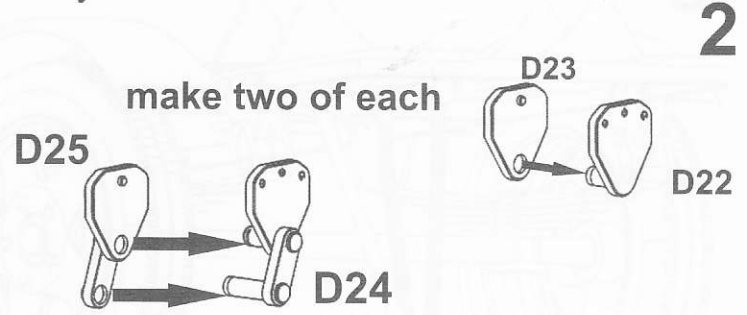
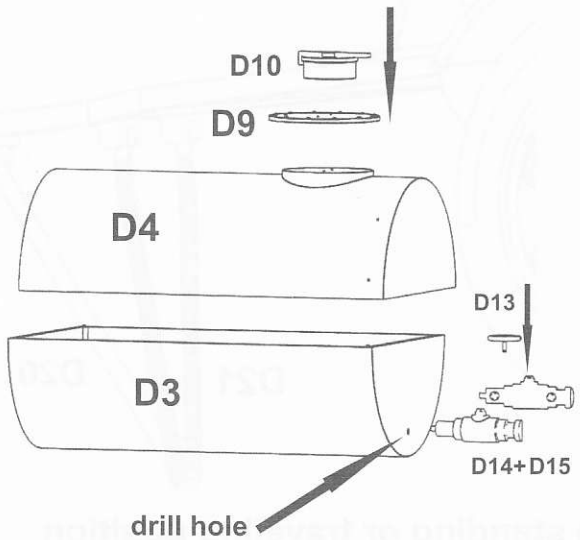

2

4

Assemble D22+D23 and D24+D25 in slots in D1

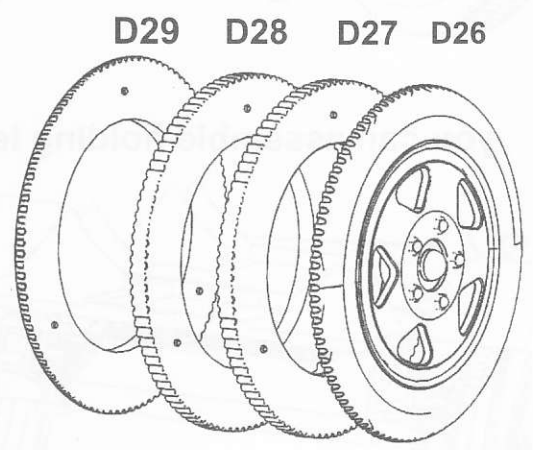
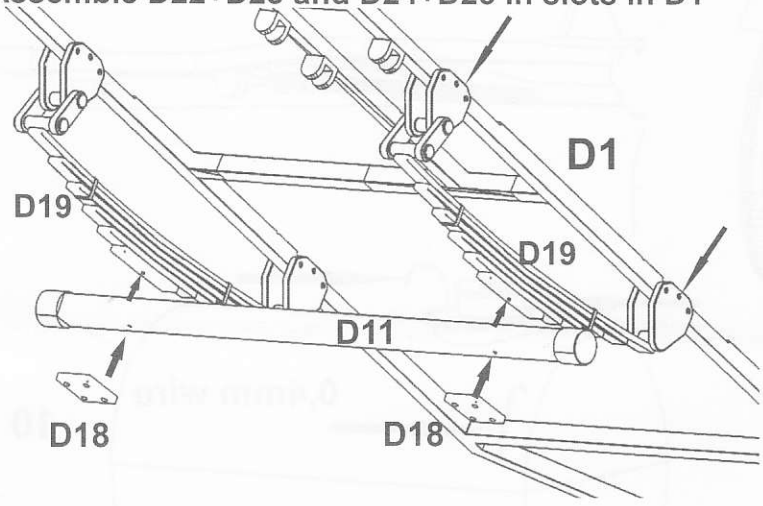

3

make two

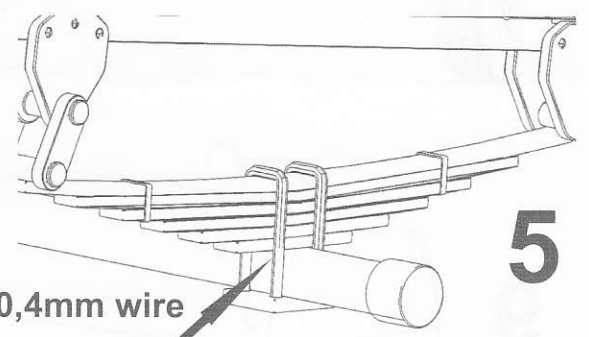

5

6

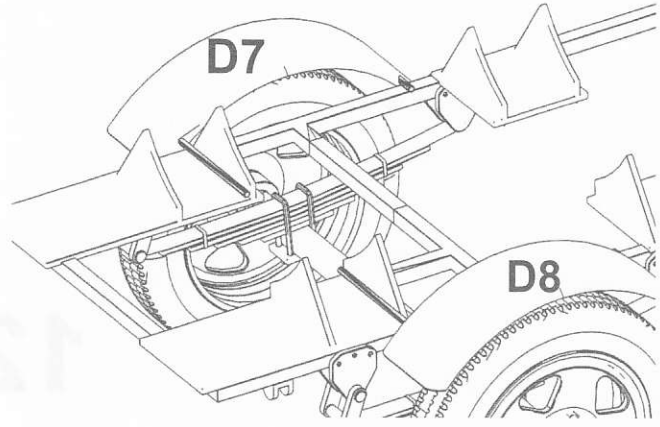
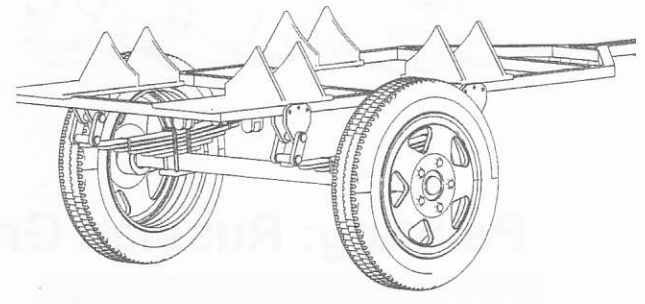
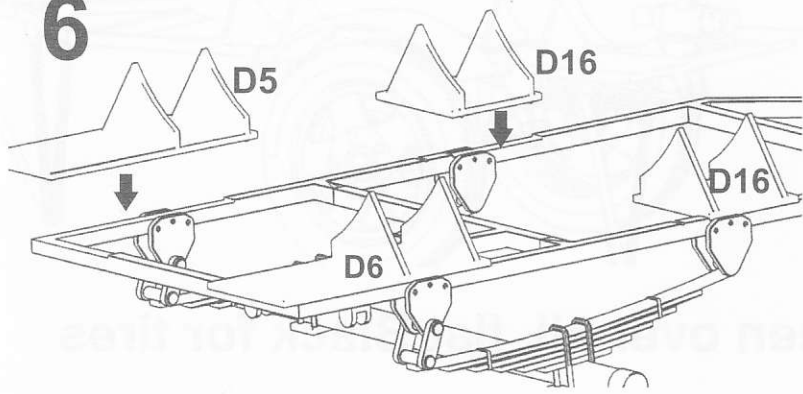

11

8

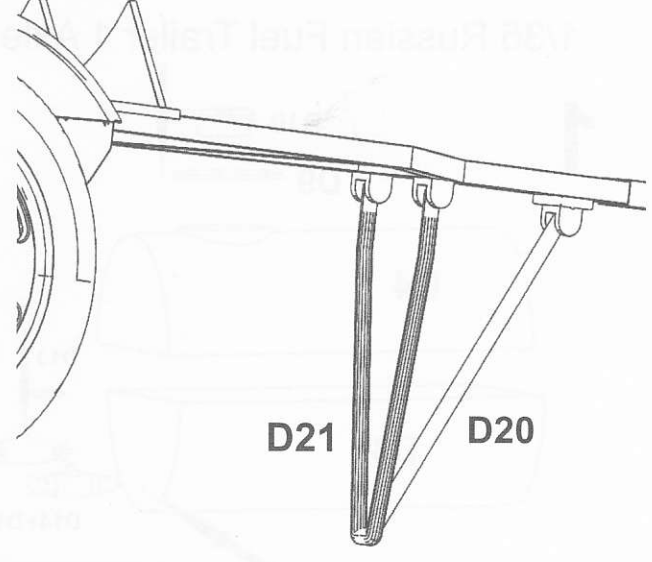
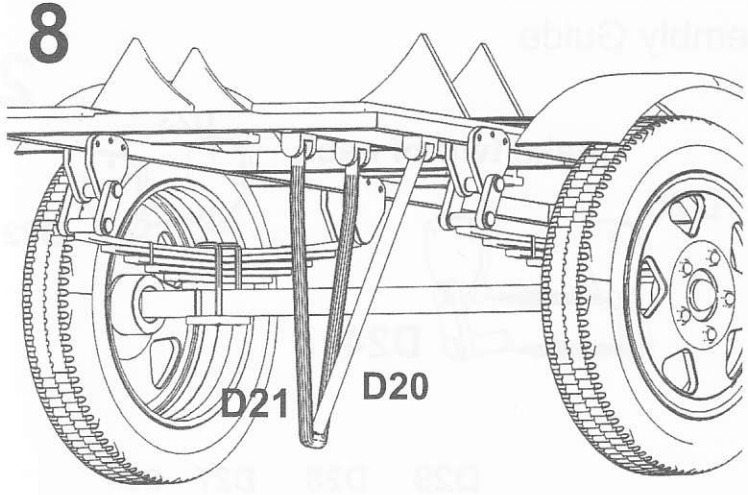

you can assemble holding legs either in standing or traveling position

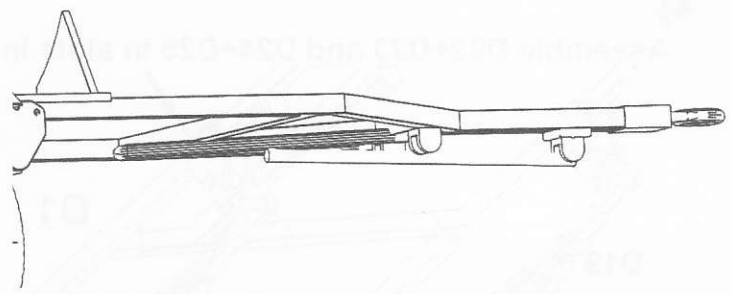
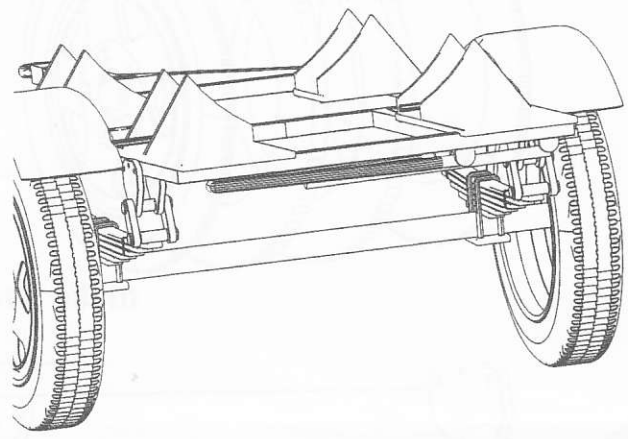

9

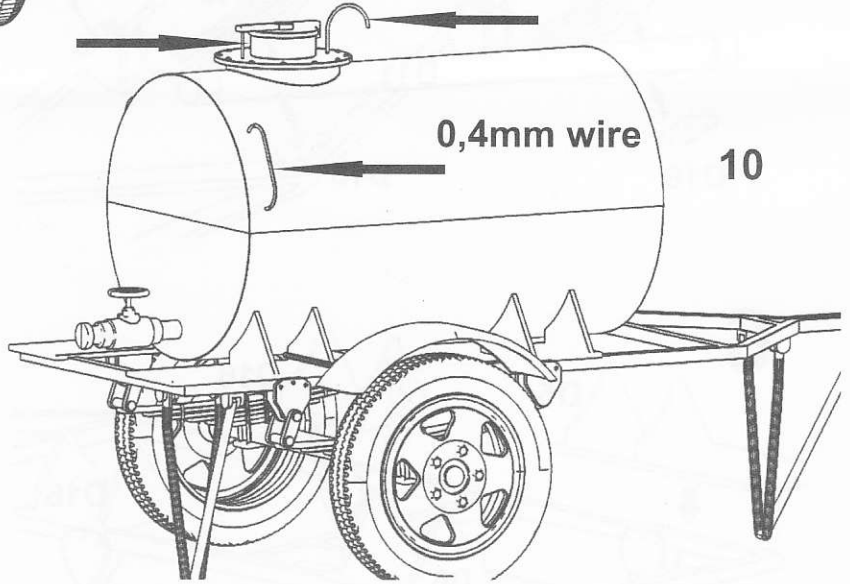
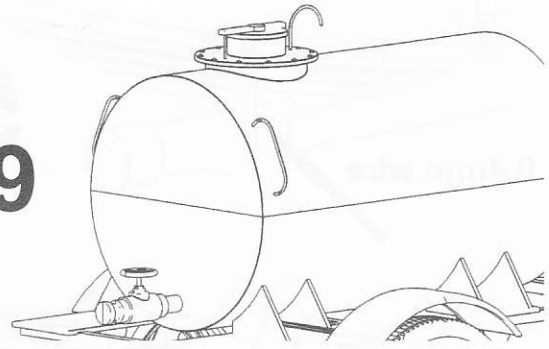

Painting: Russian Green over all, flat Black for tires

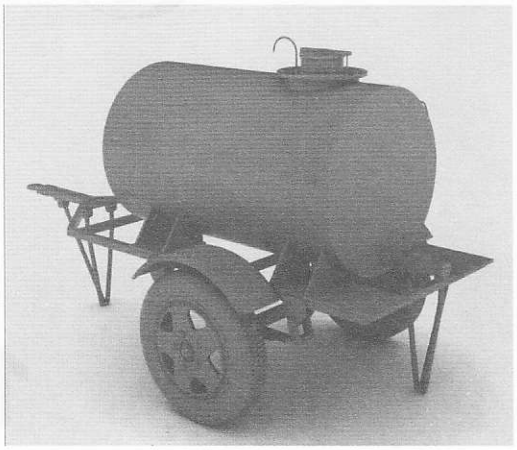

12