

# RAF Avro Vulcan B.2 Detail Set

It is highly recommended that you get hold of Issue No.3 of Wings of Fame, published by Aerospace Publishing, as this contains a major feature on the Vulcan. It includes a wealth of photographs, and markings and unit information.

The circled part numbers on the diagrams relate to kit parts, and the areas to be removed from any of these parts are shown as shaded.

It is possible to portray B.2 Vulcans at most points in their careers by using the different aeriels in the set - we have provided some notes on the drawings to assist in what was fitted where, and when, but you will doubtless be able to find variations on the guidelines given.

*These instructions refer to the use of Airwaves [ex-DB Productions] ejector seats but there are alternatives, available from Aeroclub, which will do equally as well.*



Trefacwn Fach,  
Llanrhian,  
St. Davids, Pembrokeshire,  
SA62 6DP, Wales, UK

[www.djparkins.com](http://www.djparkins.com)

## Fitting of Series 200 Jet Pipes

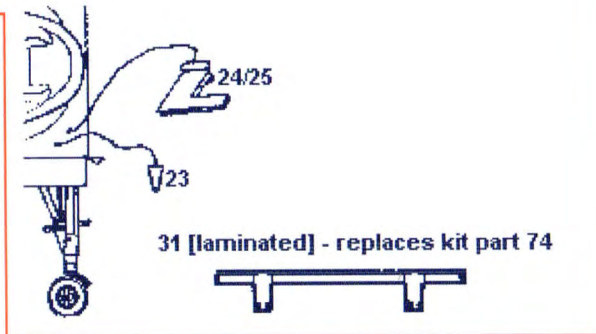
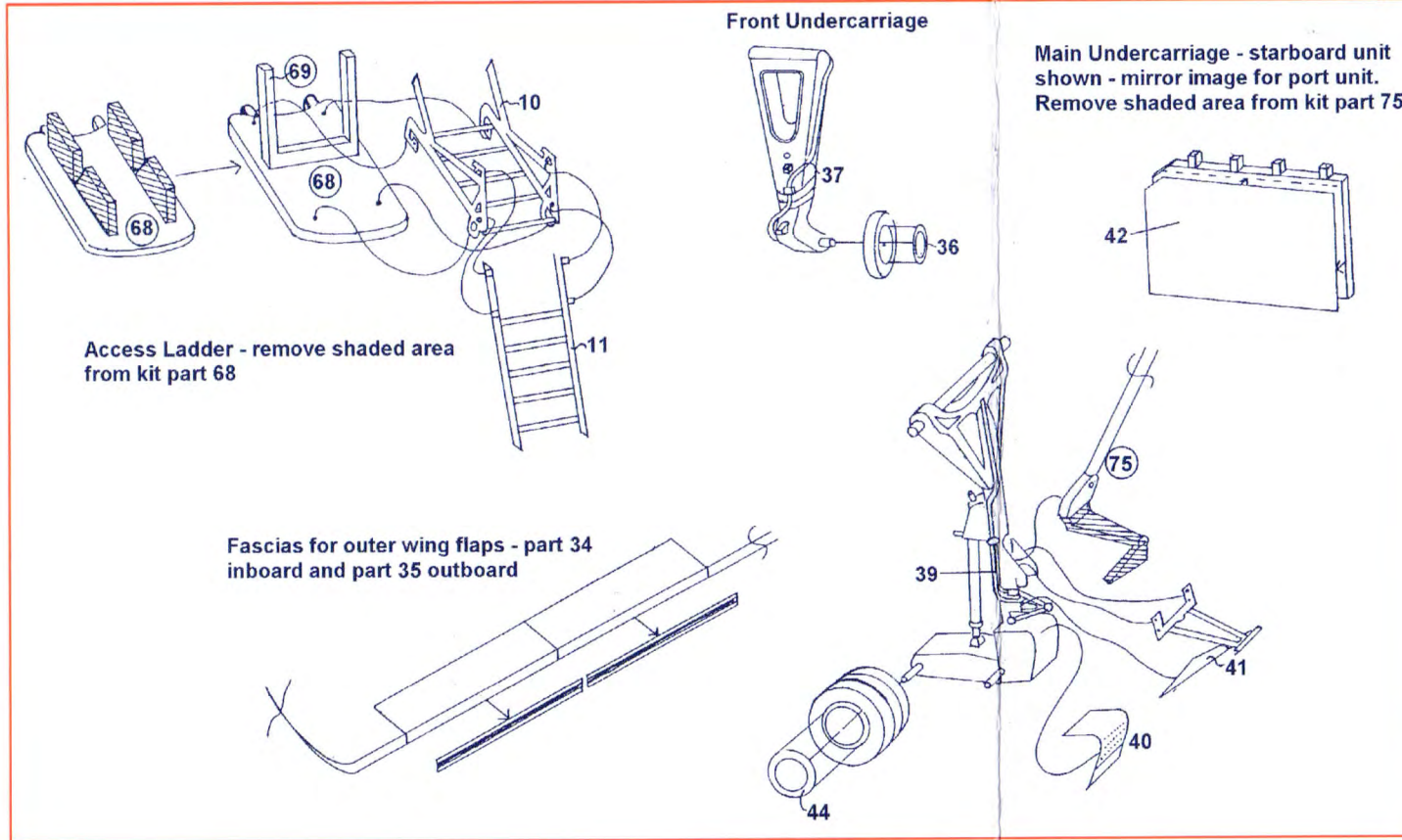
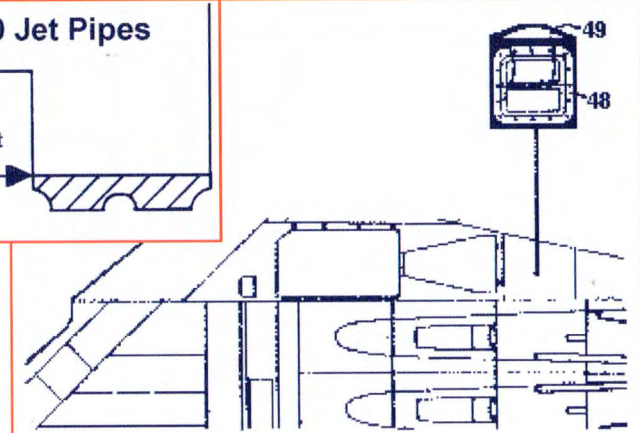
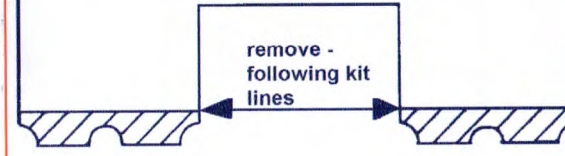



**Cockpit Canopy**

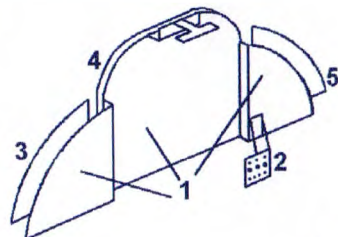
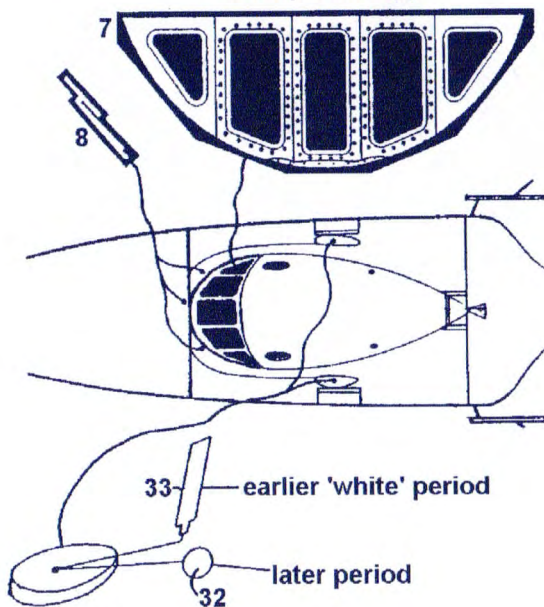

**Air Brake Units** - cut slots in wing upper surfaces using parts 12 as templates, prior to assembling the units

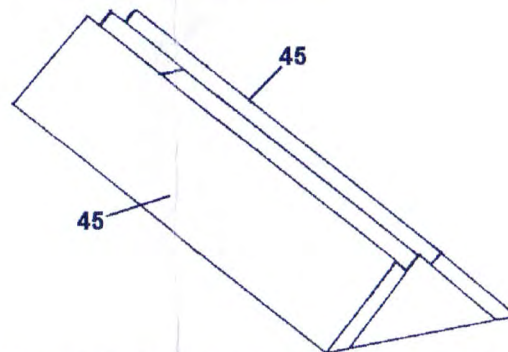

**Assembly of wheel chocks - main wheels**

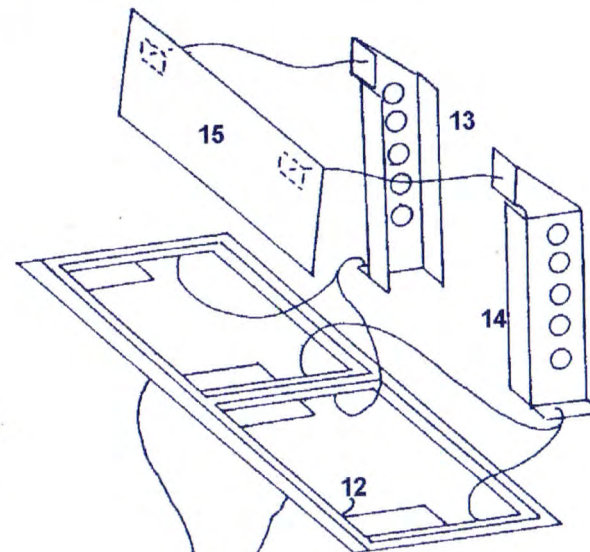

**Ejector Seats** - we recommend the use of the ED models [ex-DB Conversions] Mk.3/4 seats. Etched pull handles [parts 6] are supplied for these.

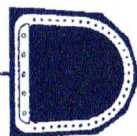
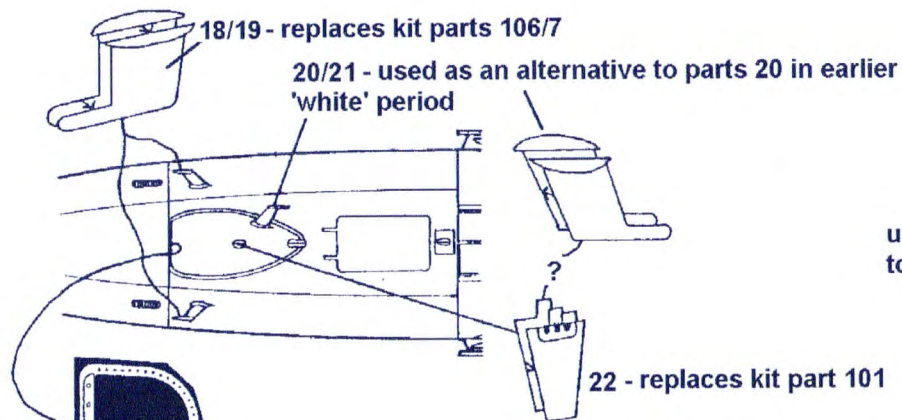

**Bomb Aimer's Viewing Panel**

