



DASSAULT MIRAGE III O

K 072016

1/72 Scale Model Construction Kit

HISTORY

The Dassault Mirage is one of the most successful French aircraft designs of the post-war era, and an outstanding third generation jet fighter. The Mirage III prototype first flew in 1956 benefitting greatly from the work done on the experimental Fairey FD-2 Delta. It entered service with the French Air Force in 1961.

The second major version, the Mirage IIIE, was selected by the Royal Australian Air Force as a supersonic replacement for the Rolls Royce Avon powered CAC Sabre. The Avon engine was also used on RAAF Canberra bombers and plans were made to produce the Mirage III with an engine from the same family. In the end the original SNECMA Atar 9C engines were retained, although the avionics fit was changed to meet RAAF needs. The first two examples were built in France and the following 98 at the Government Aircraft Factory (GAF) in Australia.

The Mirage IIIO entered RAAF service in 1964 with 2 Operational Conversion Unit at Williamtown. The first operational unit was 75 Squadron, followed by 76 Squadron. By 1969 77 Squadron and 3 Squadron were also equipped with Mirages, with 3 Sqn specialising in ground attack duties.

At the time the Australian defense strategy called for 'Forward Defence' to manage threats to the Australian mainland. RAAF units were stationed in Thailand and Malaysia under the SEATO and Five Power Defence Arrangements treaties. RAAF Mirages were based at RMAF Butterworth in Malaysia and often deployed to Singapore.

In 1984 the F/A-18 Hornet began entering service with the RAAF and the squadrons gradually began converting to the new type. The final operator was 75 Squadron which converted in 1988 - 24 years after its introduction. Most of the remaining aircraft were sold to Pakistan with some going to museums.

This kit includes three decal options from the long service in the RAAF, one from 76 Squadron and two from 75 Squadron.

COLOUR TABLE

| KEY | COLOUR | SPECIFICATIONS | APPROXIMATE MATCH | | | | | |
|-----|-----------------|------------------|-------------------|---------|-------------|--------|--------|-----------|
| | | | GUNZE MR COLOR | HUMBROL | MODELMASTER | REVELL | TAMIYA | XTRACOLOR |
| A | BLACK | | H2 | 21 | 1747 | 32107 | X-01 | X12 |
| B | LIGHT GREY | approx. FS 35375 | H308 | 127 | 1728 | 32143 | XF-19 | - |
| C | BLUE GREY | approx. FS 36373 | H337 | 145 | 1721 | 32157 | XF-20 | X126 |
| D | OLIVE DRAB | BSC 381C 298 | ~H52 | ~155 | ~1711 | ~36146 | ~XF-62 | X28 |
| E | ALUMINIUM PAINT | | H8 | 56 | 1781 | 32199 | XF-16 | - |
| F | STEEL | | H18 | 53 | 1780 | 32191 | XF-56 | - |
| G | CLEAR RED | | H90 | 91321 | 4630 | - | X-27 | - |
| H | SIGNAL RED | BSC 381C 537 | H327 | 153 | 1705 | - | XF-07 | X14 |
| I | PALE GREY | approx FS 36495 | H338 | 147 | 4765 | 32371 | XF-14 | - |
| J | DARK SEA GREY | BSC 381 638 | H335 | 156 | 2059 | 32179 | XF-54 | X4 |
| K | PALE GREY | - | - | 40 | - | - | - | - |
| L | YELLOW | BSC 381C 368 | H329 | 24 | 1569 | 35115 | | X11 |
| M | FRENCH GREY | BSC 381C 630 | ~H315 | ~183 | - | - | ~XF-20 | - |
| N | LIGHT GULL GRAY | FS 36440 | H325 | 129 | 1730 | - | ~XF-55 | ~X15 |
| O | AMC GRAY | FS 36173 | ~H53 | 156 | 2035 | - | ~XF-53 | ~X4 |

CONSTRUCTION

1

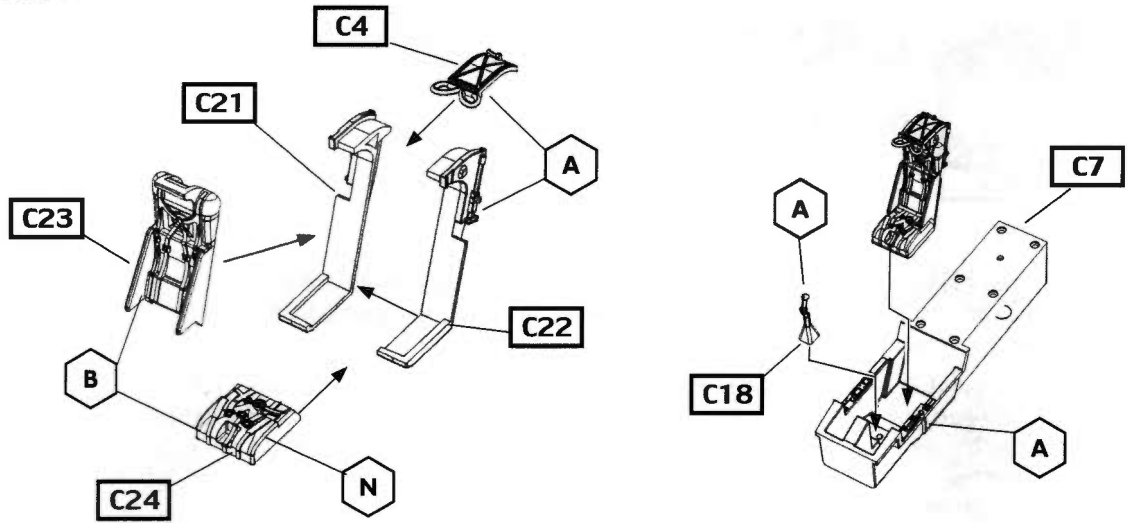

2

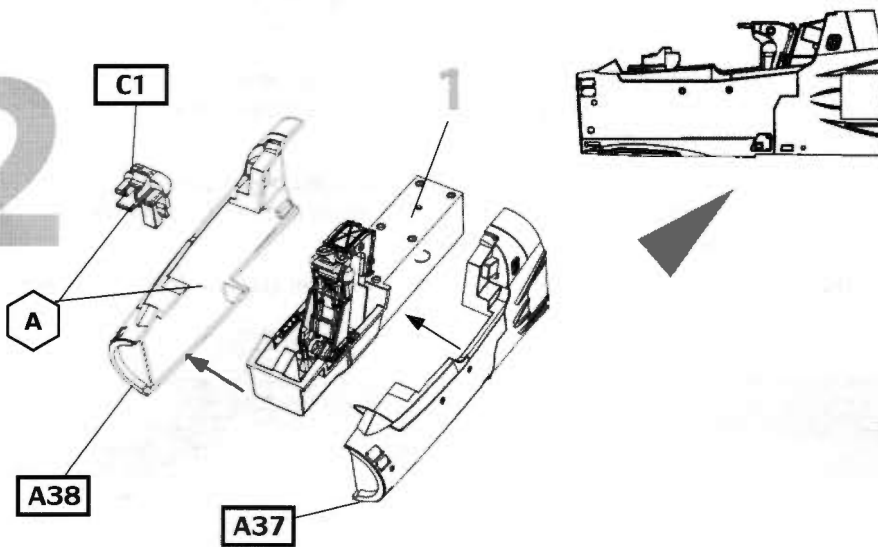

3

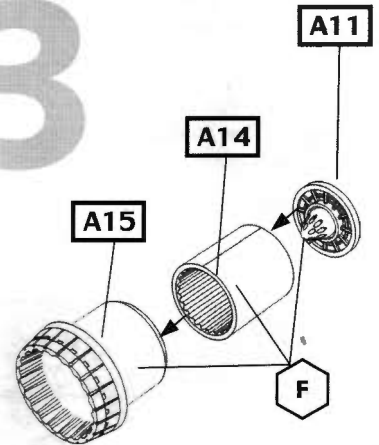

4

Remove pitot from tail

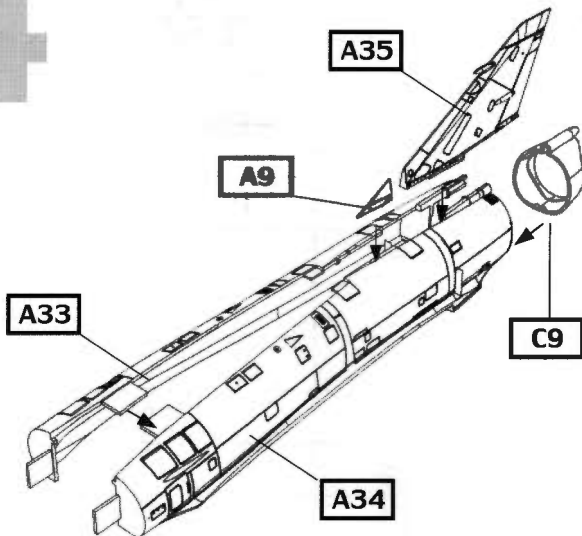

5

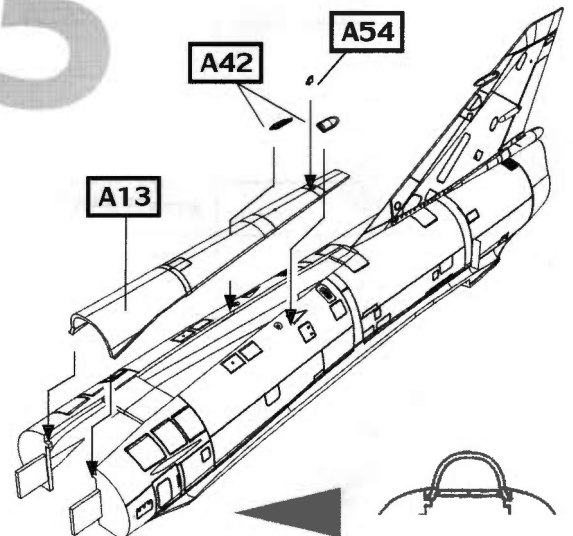

6

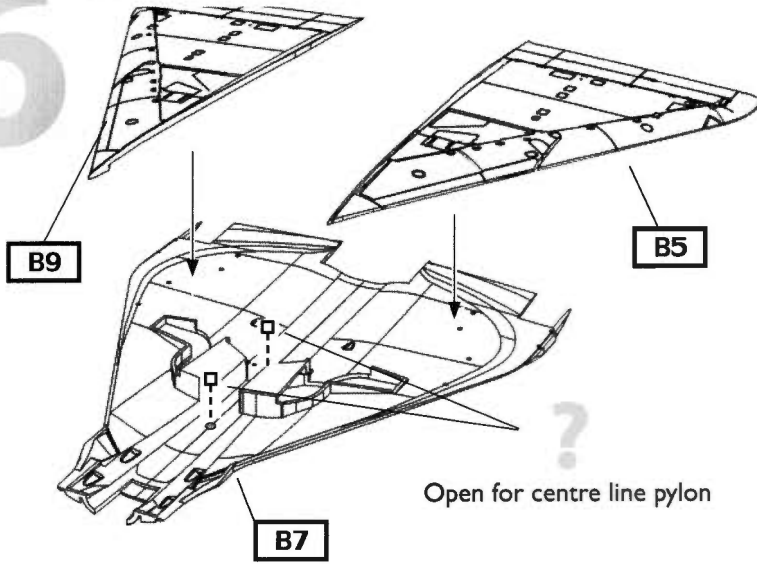

Open for centre line pylon

7

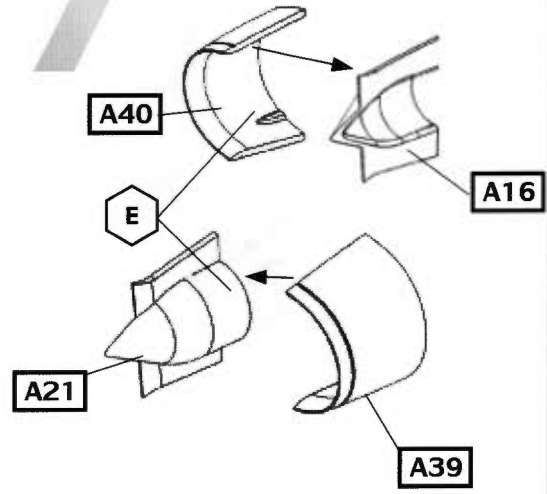

8

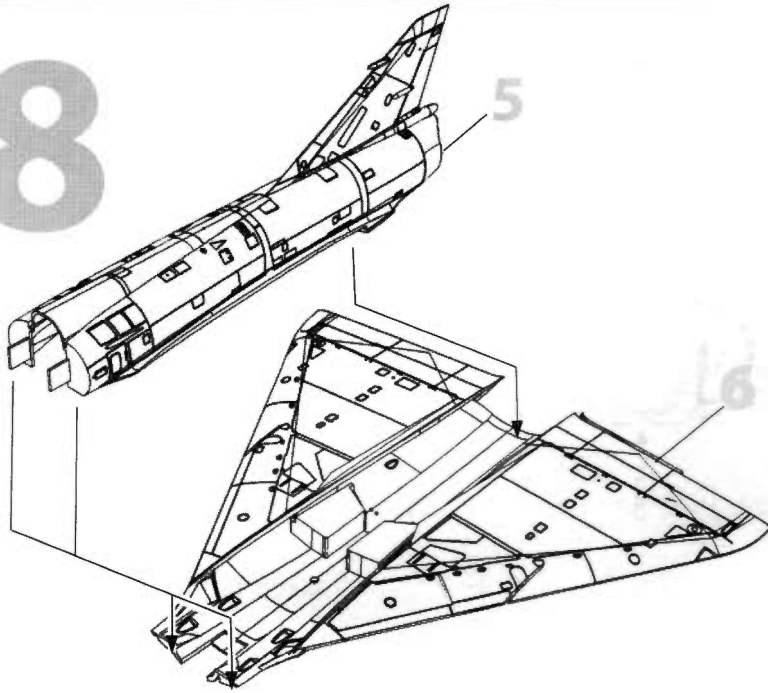

9

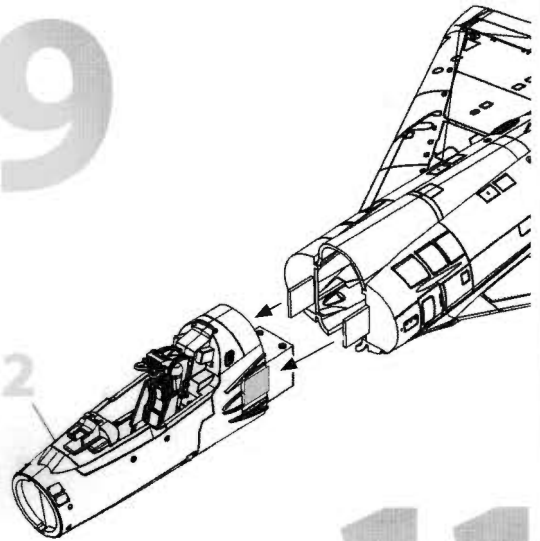

11

10

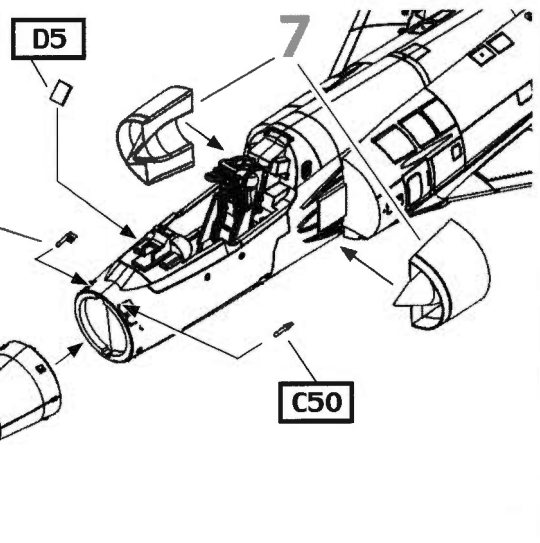
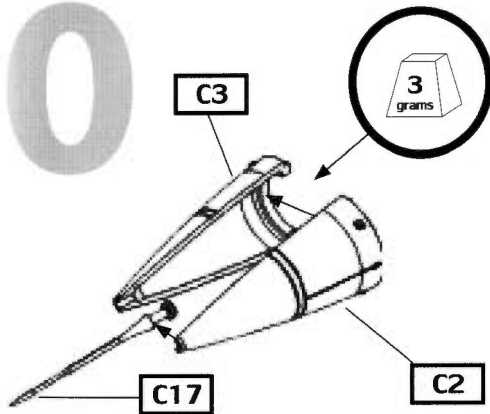

10

12

E45
A45

E46
A46

A17

E46
A46

E45
A45

SMALL INTAKE

A25a

E

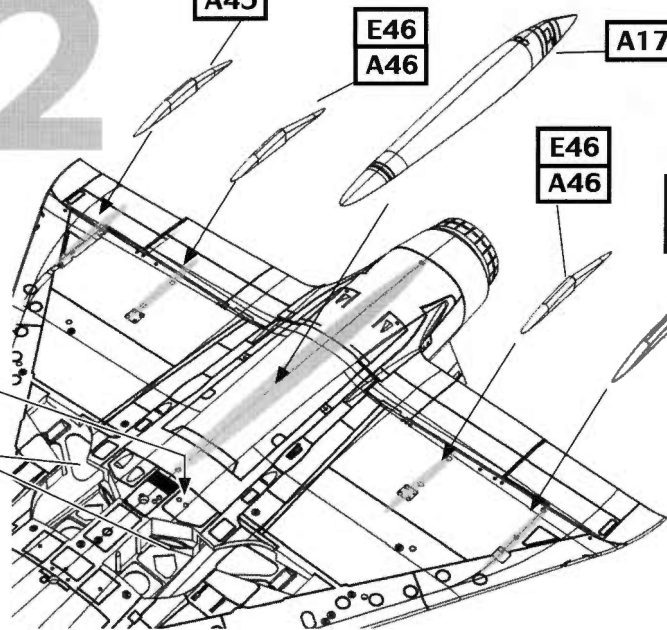

13

| | |
|-----|-----|
| L | R |
| A29 | A28 |

A20

A10

E

A

E

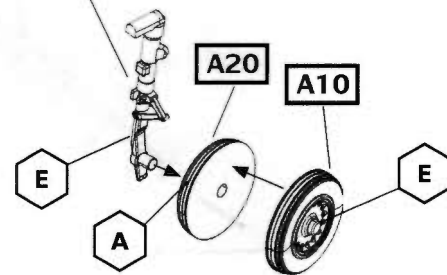

15

A23

A53

A47

A53

A8

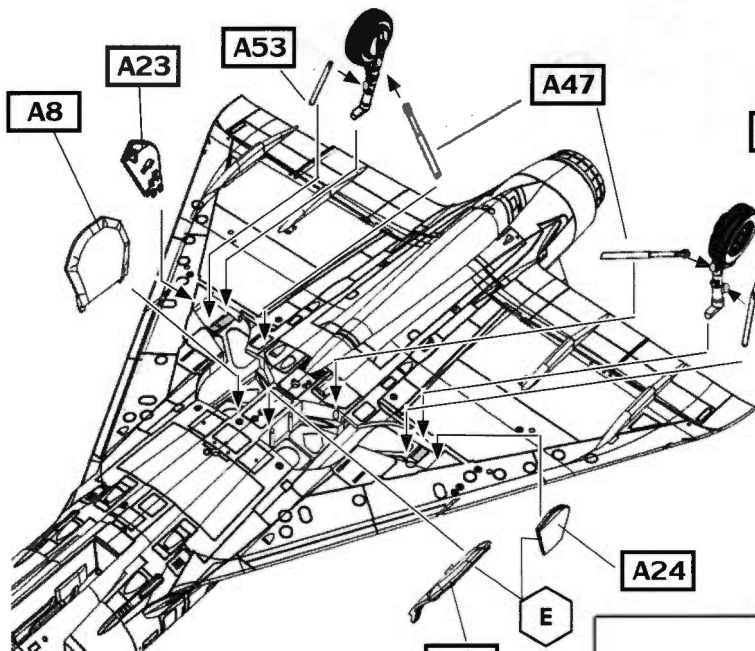

14

A27

A19

A26

D6

A

E

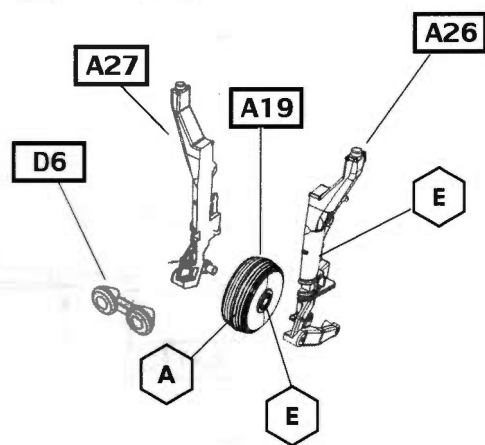

16

A30

A41

A1

A2

A30

E

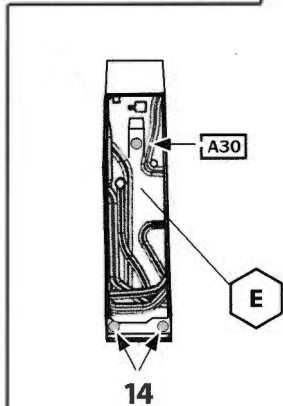
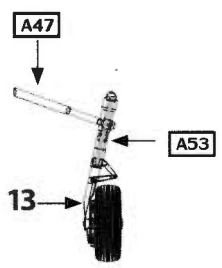
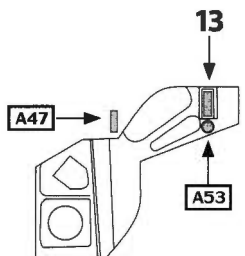
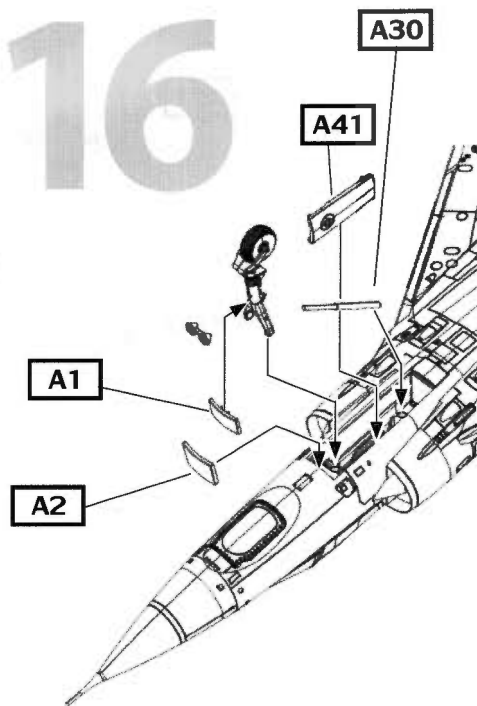

15

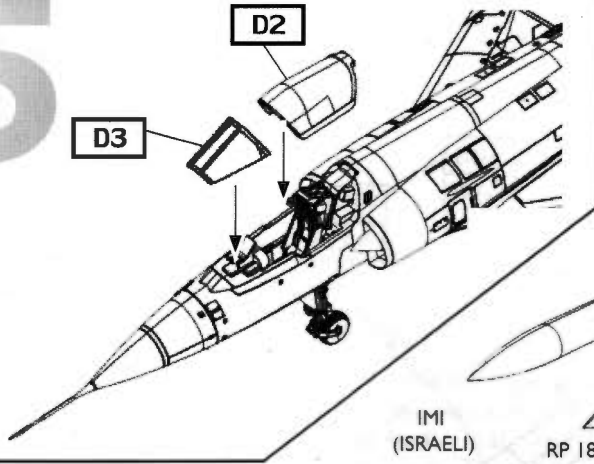

16

IMI (ISRAELI)

RP 18 (FRENCH)

SUPERSONIC TANKS
500 L (110 Gal)

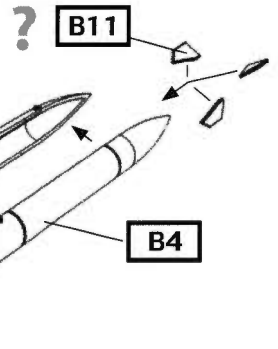

17

RP 62 TANK
1300 L (374 Gal)

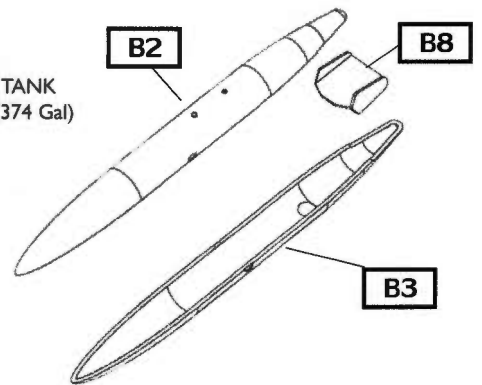

NOT TO SCALE

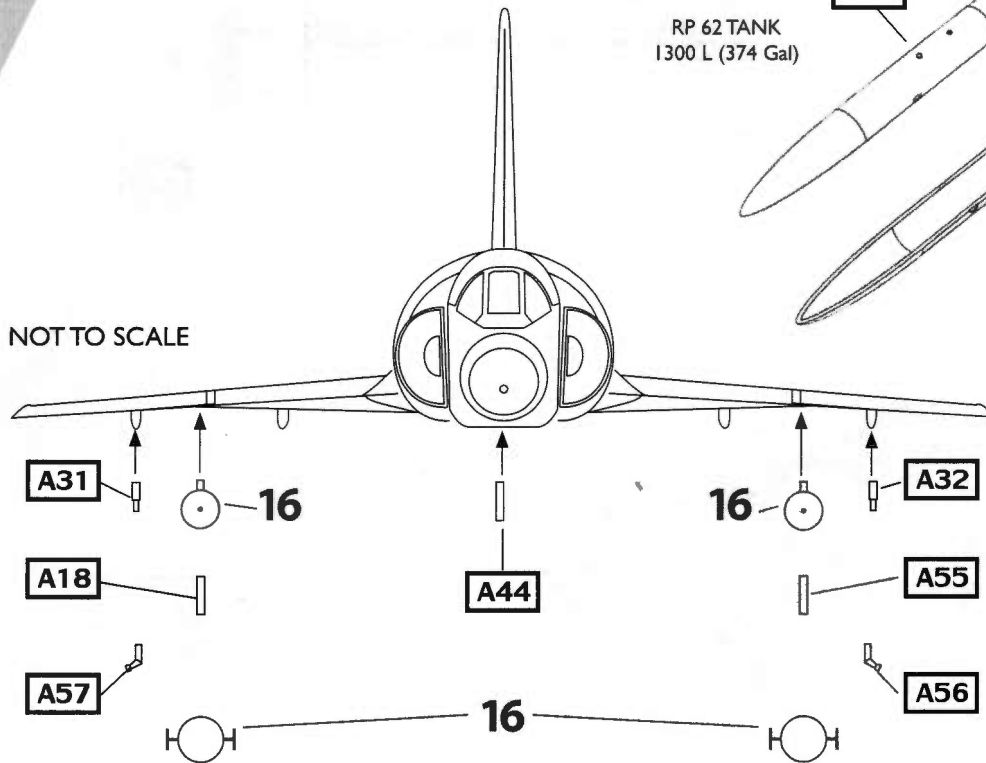

Stores not included - for information only

AIM-9B SIDEWINDER ✕
MATRA R.550 MAGIC ✕

MATRA R.530K

✕ AIM-9B SIDEWINDER
✕ MATRA R.550 MAGIC

MATRA R.530K

PM-3 RACK
MK 82 500 lb BOMBS

MATRA R.530K

RP30 TANK
1600 L (608 Gal)



DASSAULT MIRAGE III0



76 SQUADRON RAAF

Williamtown, Australia
Late 1960s-1974

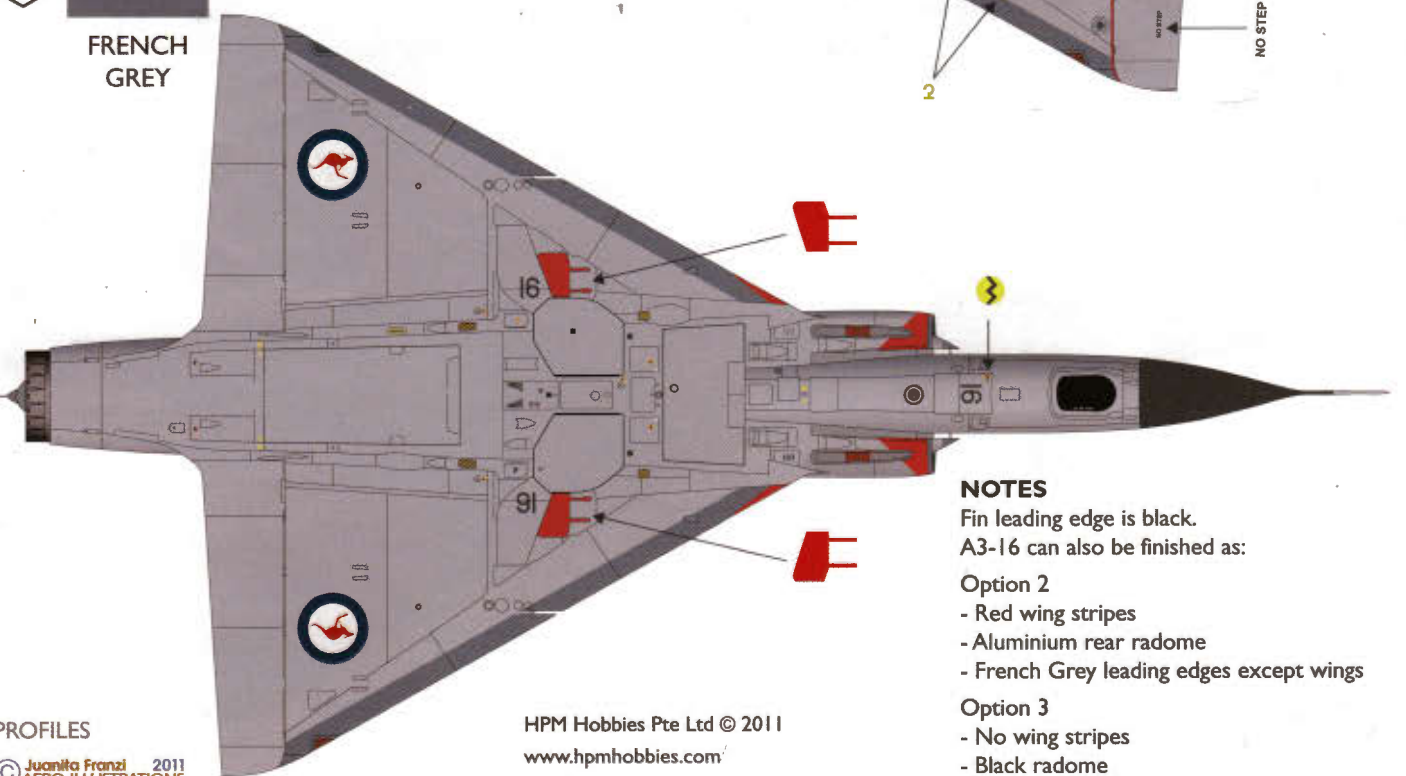
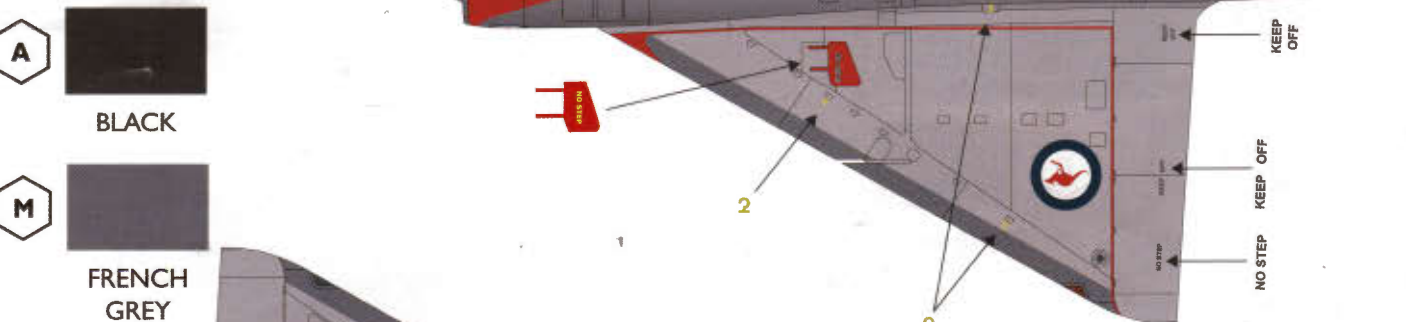

NOTES

Fin leading edge is black.
A3-16 can also be finished as:

Option 2

- Red wing stripes
- Aluminium rear radome
- French Grey leading edges except wings

Option 3

- No wing stripes
- Black radome
- Extra Dark Sea Grey leading edges

PROFILES

© Juanita Franzl 2011
AERO ILLUSTRATIONS
www.aerollustrations.com

HPM Hobbies Pte Ltd © 2011
www.hpnhobbies.com
info@hpnhobbies.com



DASSAULT MIRAGE IIIIO

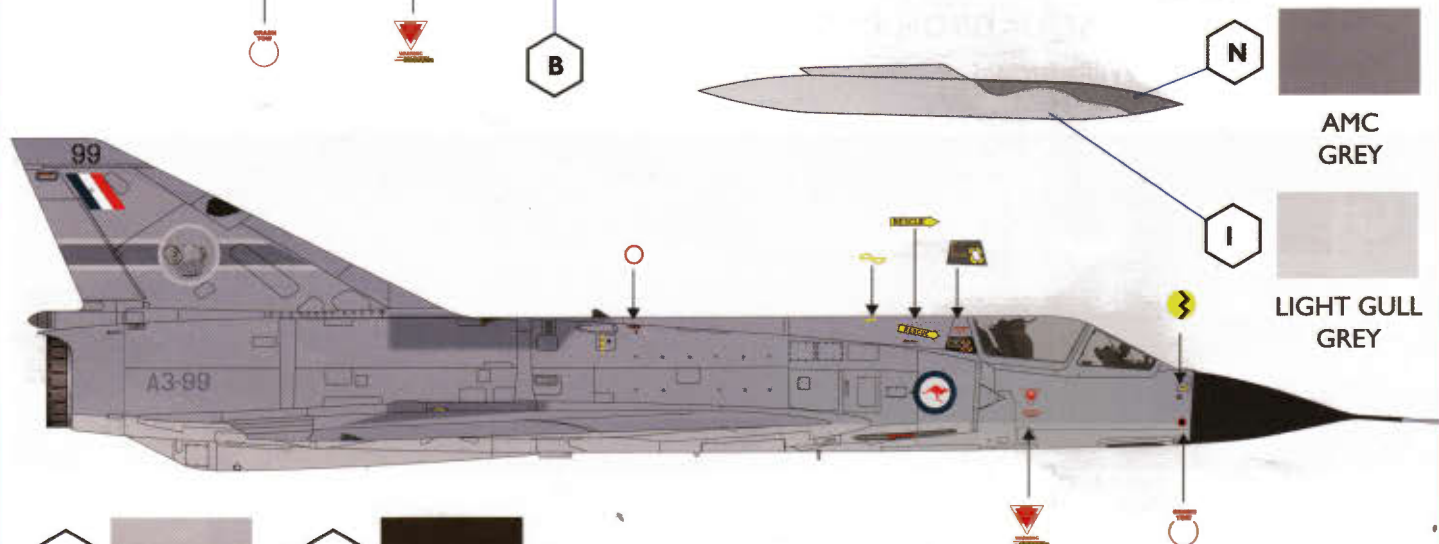
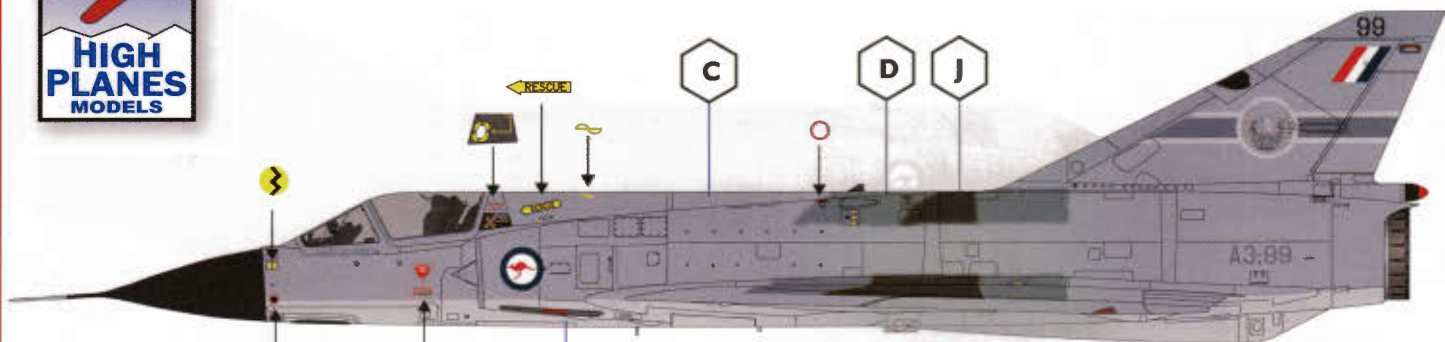

AMC
GREY



LIGHT
GULL
GREY



LIGHT GREY



OLIVE DRAB



BLUE GREY



EXTRA DARK
SEA GREY

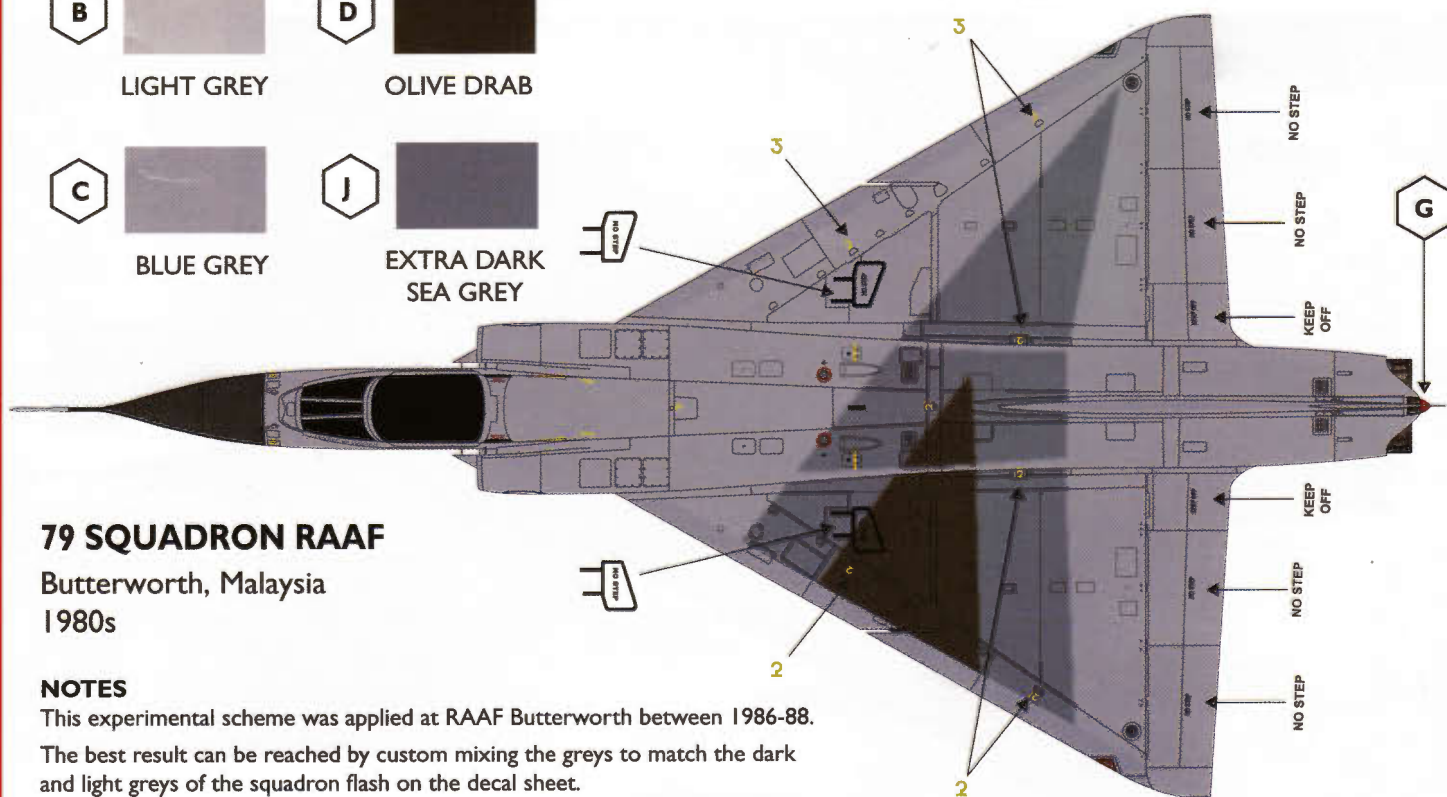

79 SQUADRON RAAF

Butterworth, Malaysia

1980s

NOTES

This experimental scheme was applied at RAAF Butterworth between 1986-88.

The best result can be reached by custom mixing the greys to match the dark and light greys of the squadron flash on the decal sheet.

If fitting supersonic tanks, they are FS 36440 Light Gull Grey with FS 36173

AMC Grey disruptive upper



DASSAULT MIRAGE IIIIO

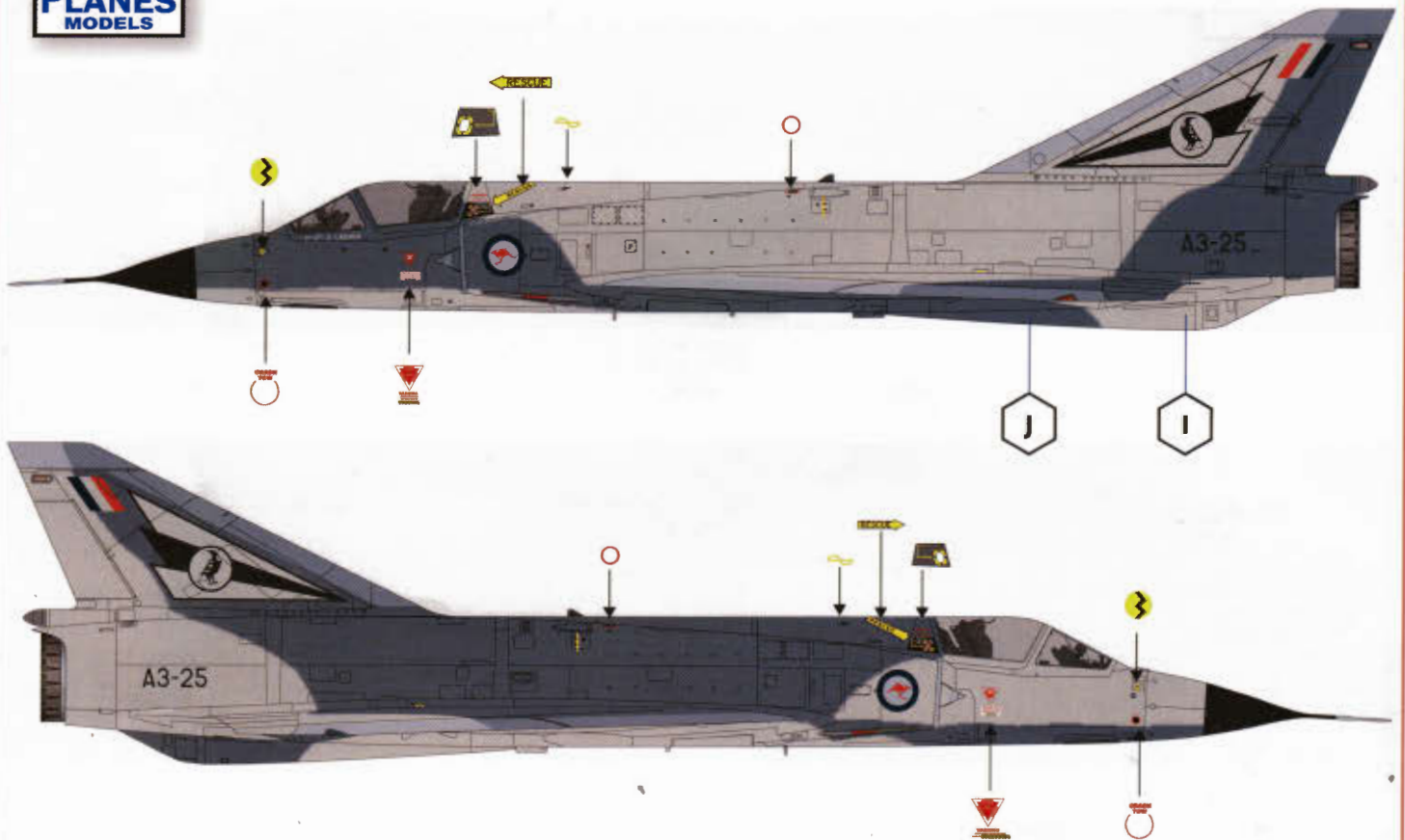

LIGHT
GULL GREY



EXTRA DARK
SEA GREY

75 SQUADRON RAAF

Butterworth, Malaysia

1981-2

NOTES

This experimental scheme was applied at RAAF Butterworth and the exact colours are not known although the relative shades are as presented.

The decals for the insignia and the squadron crest has been printed with a transparent background. Mask the area for the roundels, fin flash and crest with the colour you have used for the Pale Grey areas then apply the decal. The underwing roundels have white centres as normal.

The leading edges of RAAF Mirages were generally BSC 381C 630 French Grey in the early years of operation and BSC 381C 640 Extra Dark Sea Grey later. This aircraft is the exception as the leading edges are quite light, but lack the slight green hue of French Grey. The lighter tone is close to FS 26375, but a little more blue, and the darker tone close to FS 25526 but a little less blue

If fitting supersonic tanks they are Dark Sea Grey overall.



DASSAULT MIRAGE IIIIO

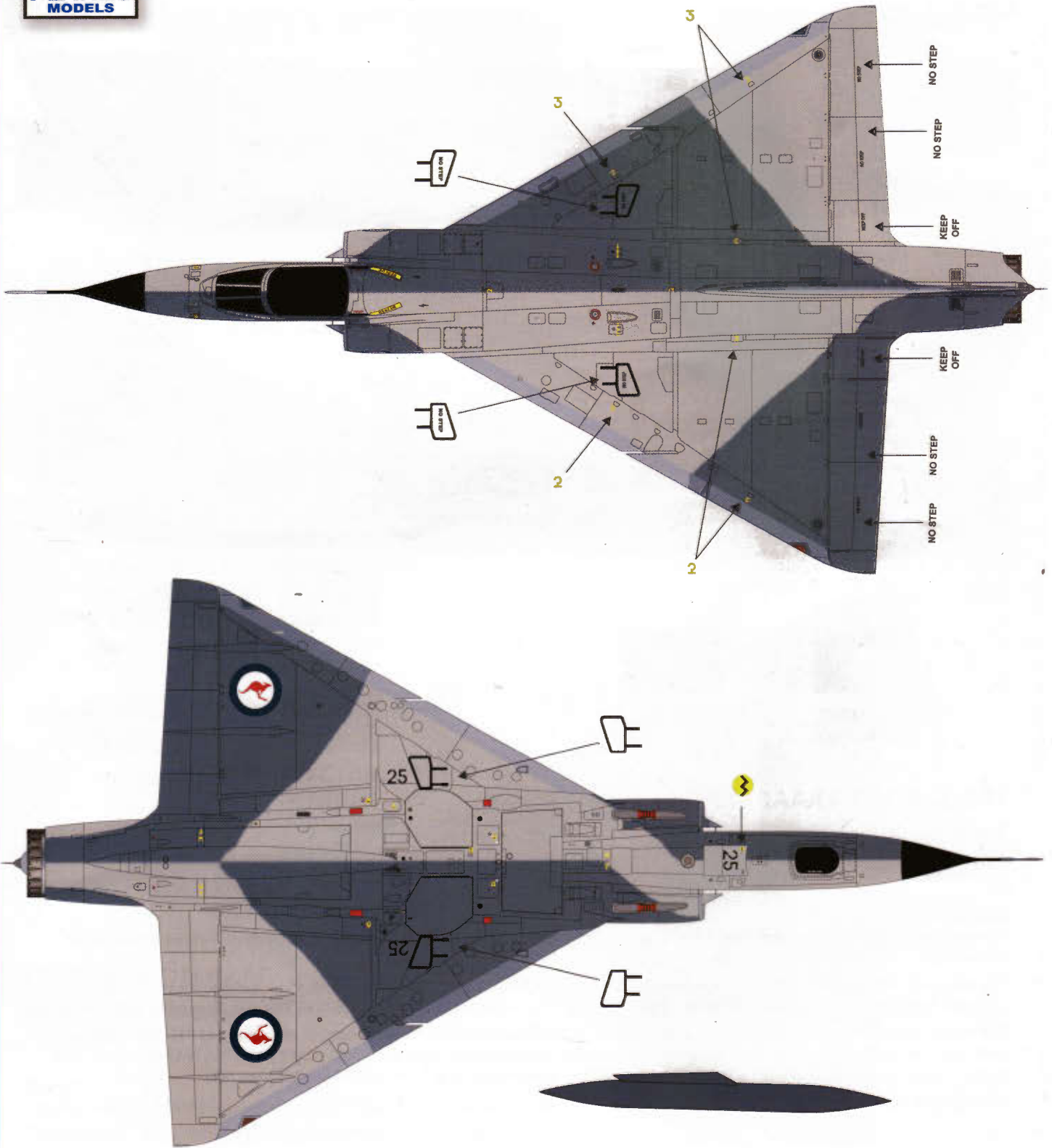

ACKNOWLEDGEMENT

We gratefully acknowledge the assistance of Michel Givord, Juanita Franzi, Darren Mottram and Michael Evans in preparing this kit.