

# Heinkel He 162 A „Volksjäger“

● one Jumo 004 D turbojet ● /GERMAN PROJECT WW II/

## Heinkel He 162 A-8

One of the last types of the He 162 A series of single-seat interceptor fighters - the He 162 A 8 - had to be powered with the Jumo 004 D turbojet providing 2050 lb s.t. for take off. This power plant was envisaged instead of the originally planned BMW 003 E turbojet, where shortages of this power plant were expected. The anticipated maximum speed of this aircraft was 551 m.p.h. at 19.085 ft (887 km/h at 6000 m). At a loaded weight of 6.220 lb (2820 kg) the He 162 A-8 was expected to attain an altitude of 19685 ft. (6000 m) in 5,3 minutes.

The He 162 A-8, as a number of other planned types of the He 162 A series, did not attain production status.

## Heinkel He 162 A-8

Einer der letzten Typen der He 162 A-Reihe des Einsatz-Abfangjägers-He 162 A 8 - sollte mit der Jumo 004 D Strahltriebwerke, die für den Start 430 kp Standschub leistete, angetrieben werden. Dieses Triebwerk wurde anstatt der ursprünglich geplanten BMW 003 E Strahltriebwerke, wo Mangel an diesen Triebwerken erwartet wurde, erwogen.

Die angenommene Höchstgeschwindigkeit dieses Flugzeugs war 887 km/h in 6000 m Höhe. Bei einem Fluggewicht von 2820 kg wurde erwartet, dass der He 162 A-8 Typ eine Höhe von 6000 m in 5,3 Minuten erreichen wird. Das He 162 A-8 Flugzeug, gleich wie eine Anzahl von anderen geplanten Typen der He 162 - Reihe, erreichte keinen Produktionsstand.

## Heinkel He 162 A-8

Un des derniers engins de la série He 162 A monoplace le chasseur intercepteur He 162 A-8, devait être mu par le turbo-jet JUMO 004 D fournissant une poussée de 1025 kg. Ce groupe moteur fut projeté à la place du turbo-jet préalablement prévu le BMW 003 E, car on craignait l'insuffisance de ces groupe moteurs. La vitesse maximum prévu pour cet avion était de 887 Km/h à 6000 m. Lorsque son poids en charge était de 2820 Kg, le He 162 A-8 pouvait atteindre une altitude de 6000 m en 5,3 minutes.

Le He 162 A-8 comme bon nombre d'autres avions du même type dans la série des He 162 A, ne fut jamais produit.

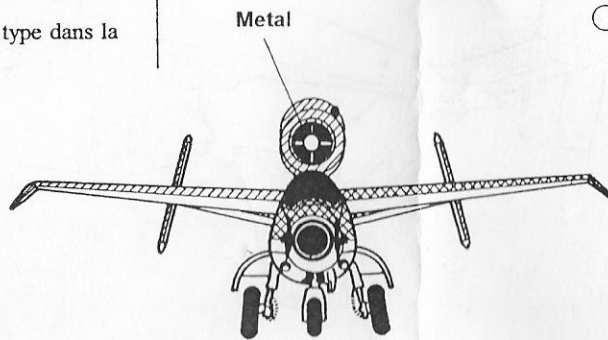
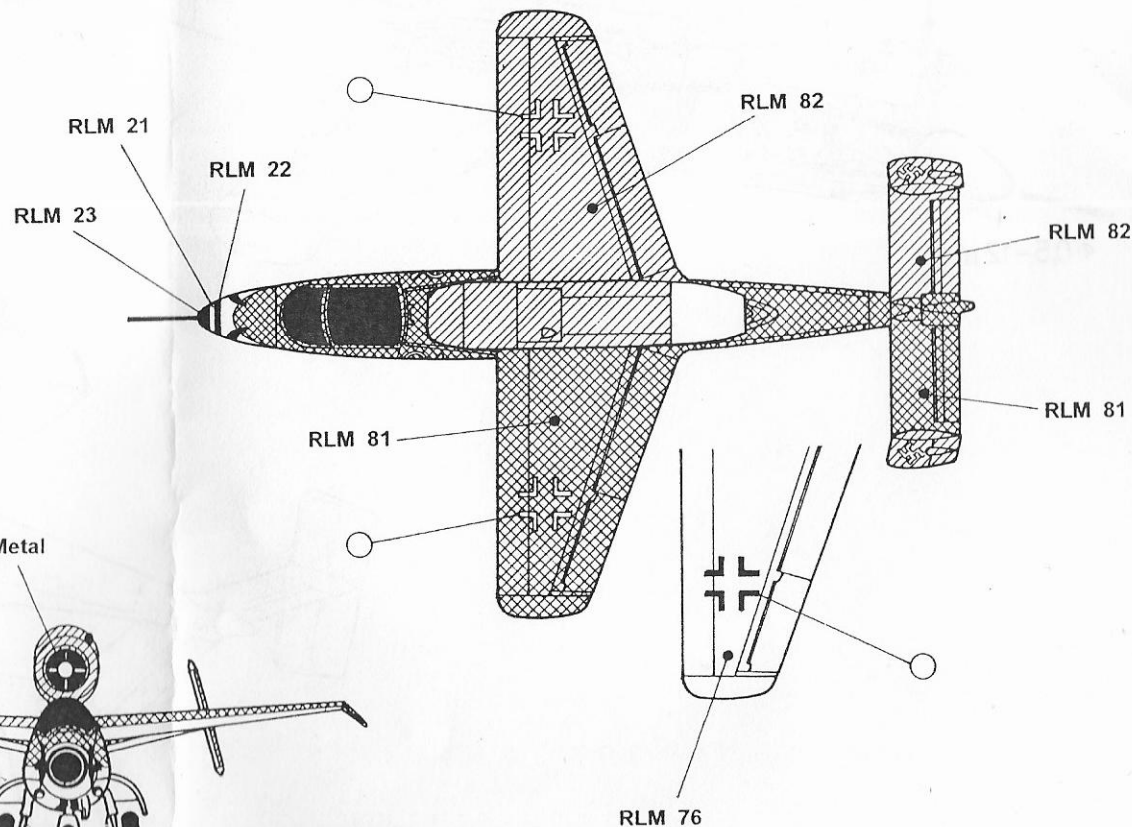
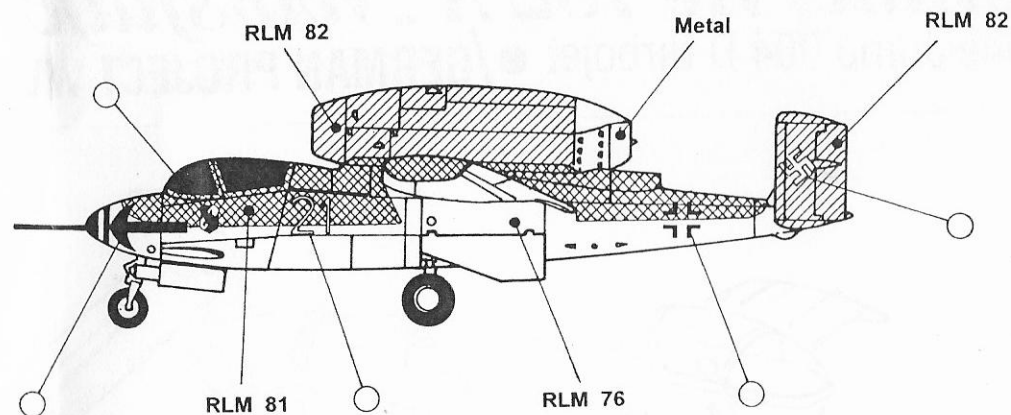



# Heinkel He 162 A „Volksjäger“

● one Jumo 004 D turbojet ● /GERMAN PROJECT WW II/

1:72  
No. 007

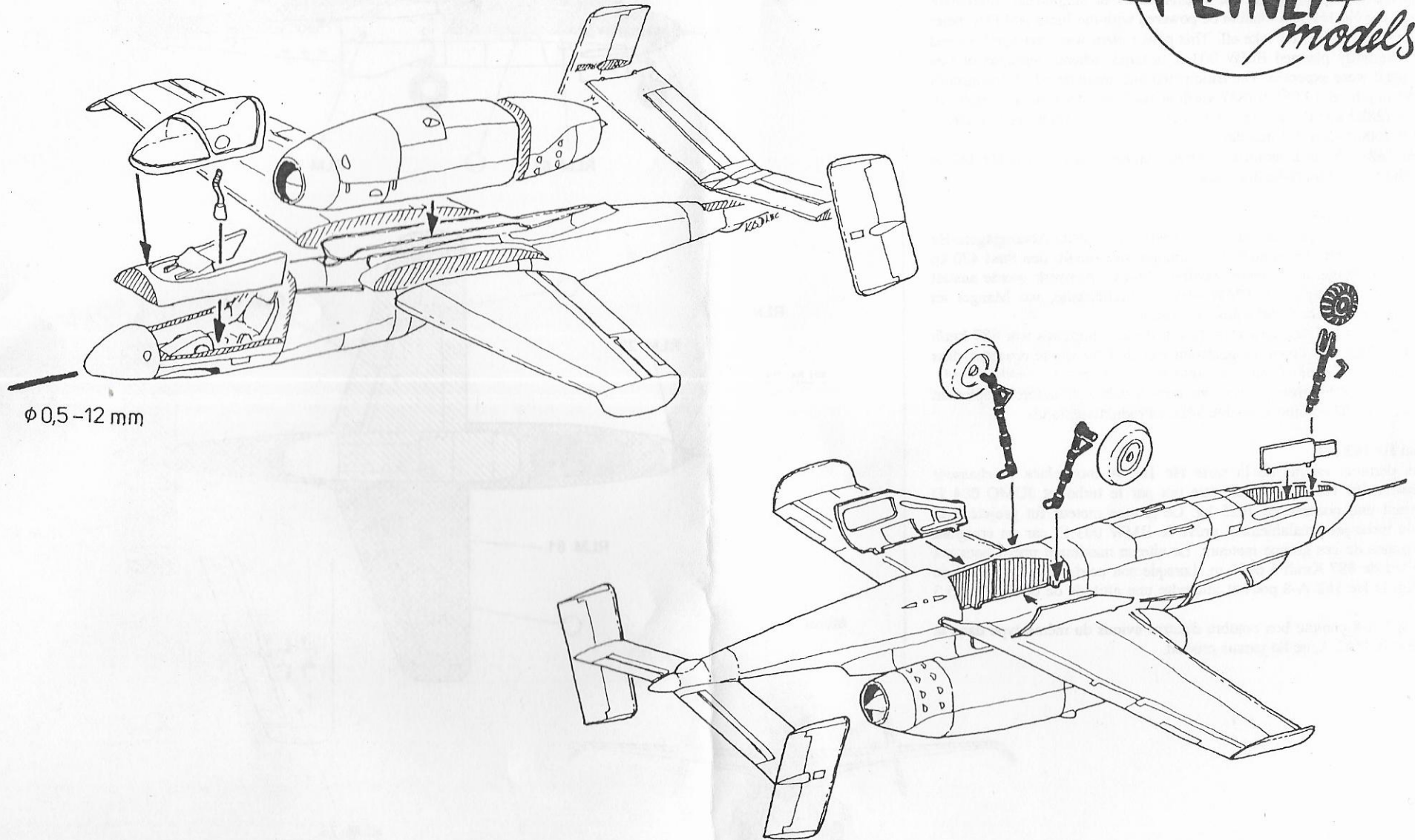

Made in Czech Republic

PLT 007, PLT 008, PLT 009, PLT010  
HEINKEL He 162 "Volksjager"

7 5 21 24

7 5 21 24

99 99  

    
  

# Heinkel He 162 A „Volksjäger“

● one Jumo 004 D turbojet ● /GERMAN PROJECT WW II/

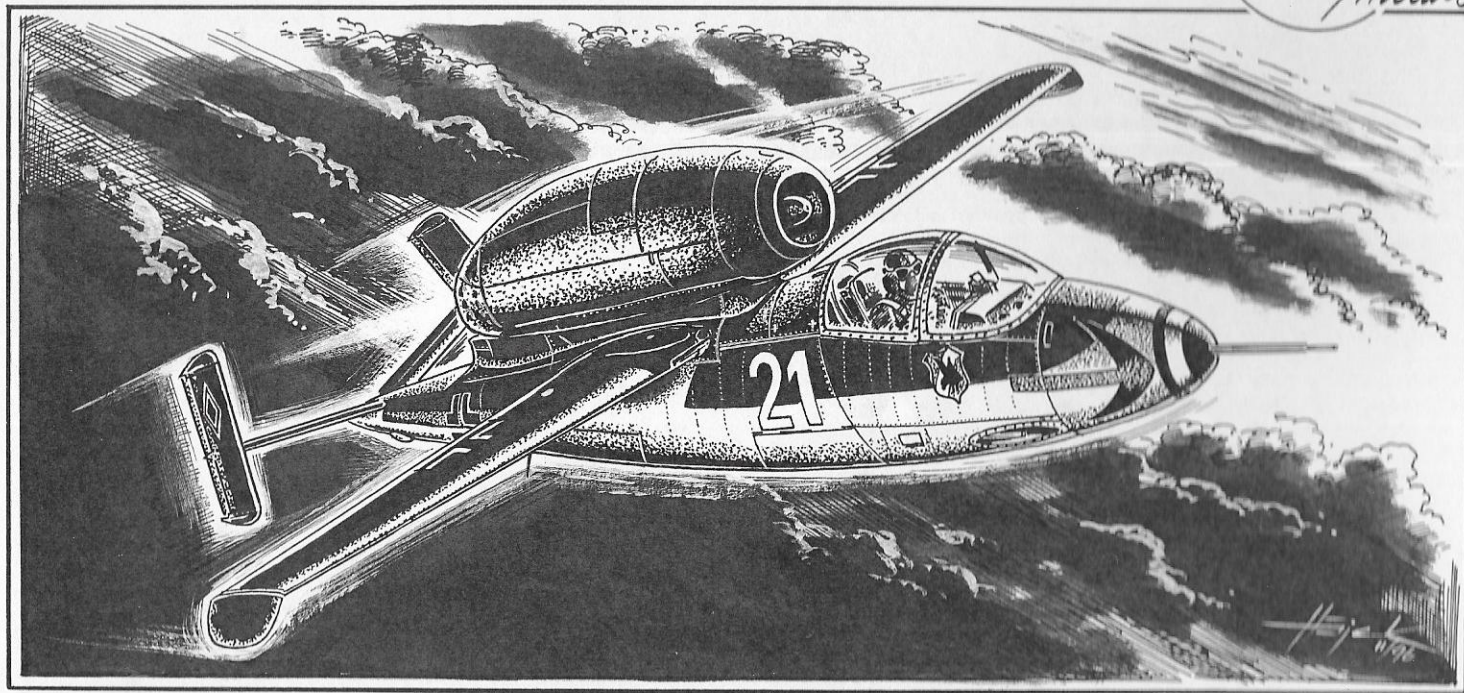

Made in Czech Republic