

# La-5

## HC1589 • 1:48 • WWII Soviet Fighter

**Aircraft Type:** fighter  
**Scale:** 1:48  
**Country Of Origin:** USSR

Universally considered one of World War II's most outstanding fighters, highly maneuverable La-5's were the chosen mounts of many famous Soviet pilots — including ace Vitali Popkov. Nearly 10,000 of these rugged wooden machines were manufactured. Kit features: detailed cockpit • landing gear • precise moldings • authentic markings.

**Type d'avion:** chasseur  
**Echelle:** 1:48  
**Pays d'origine:** USSR

Universellement considéré comme l'un des chasseurs les plus remarquables de la 2ème guerre mondial, également très manoeuvrable, le La-5 fut choisi par les plus célèbres pilotes soviétiques tel que Vitali Popkov. Ces robustes machines en bois furent construites à près de 10 000 exemplaires. Particularités du kit: • l'interieur détaillé • train d'atterrissage très détaillé • moulage précis • les marques authentiques.

**Tipo di aereo:** da caccia  
**Scala:** 1:48  
**Origine:** USSR

Universalmente considerati tra i più eminenti combattimenti della 2a guerra mondiale, gli La-5 con la loro grande manovrabilità furono scelti dal più famosi piloti sovietici, includendo anche il asso Vitali Popkov. Queste resistenti macchine in legno sono state prodotte in circa 10.000 esemplari. Caratteristiche del modello: • carlinga dettagliata e carrello di atterraggio • dettagli incisi • decals autentici.

**Typ:** Jagdflugzeug  
**Maßstab:** 1:48  
**Ursprungsland:** USSR

Viele berühmte russische Piloten, wie z.B. auch Vitali Popkov flogen die Lavochkin La-5, die im 2. Weltkrieg als einer der besten und vor allem wendigsten Jäger des östlichen Kriegsschauplatzes galt. Nahezu 10 000 Exemplare dieses mehr als robusten Typs wurden in Holzbauweise gefertigt. Der Bausatz enthält: • detailliertes Cockpit und Fahrwerk • fein eingravierte Details • authentische Abziehbilder

**Typo de avion:** de combate  
**L'escala:** 1:48  
**Pais de origen:** USSR

Considerado universalmente uno de más destacados combatientes de la 2a Guerra Mundial, altamente maniobrables La-5's fueron escogidas monturas de muchos pilotos soviéticos famosos — incluyendo al as Vitali Popkov. Fueron fabricados cerca de 10,000 de estos robustos aparatos de madera. Características del kit: • se detallan la cabina del piloto y el aterrizador • marcas auténticas

cyanoacrylate glue coller cyanoacrylate Cyanoacrylate kleben incollare cyanoacrylate pegar cyanoacrylate	cut couper schneiden tagliare cortar	bend plier sich biegen piegare doblar	file / sand ponce verspachteln levigare lijar	weight a lester Gewicht zavorra lastre	drill or pierce percer bohren forare agujerear	x2 two deux zwei dos
painting instructions mode d'emploi Anleitungen der Farben istruzioni per la verniciatura instrucciones sobre la pintura	caution! attention! vorsicht! attenzione! atención	alternative en option Alternativ alternativo alternativa	cement coller kleben incollare pegar	paint peindre bemalen verniciare pintar	decal decalcomania Abziehbild decalcomania calcomanias	no! no! nein! no! no!



**Read This Before You Begin!**  
 • study the assembly drawings  
 • each plastic part is identified by number  
 • check the fit of each piece before cementing  
 • do not use too much cement to join parts  
 • model may be painted to match box illustration

**Lisez Ce Qui Suit Avant De Commencer Le Montage!**  
 • étudier les schémas d'assemblage  
 • chaque pièce plastique porte un numéro d'identification  
 • contrôler que chaque pièce soit bien conforme avant de la coller à sa place  
 • utilisez uniquement une colle spéciale pour polystyrène  
 • le modèle peut être peint conformément aux illustrations de la boîte

**Vor Zusammenbau lesen sie bitte!**  
 • studiere die Bauanleitung  
 • die Plastikteile sind gekennzeichnet durch ihre Nummern  
 • vor dem Kleben prüfe ob die Teile zusammenpassen können  
 • benutze nicht zuviel Klebstoff  
 • die Bemalung des Modells kann auf dem Becketbild zeigen

# 1 Cockpit Assembly / Assemblage de L' Interieur

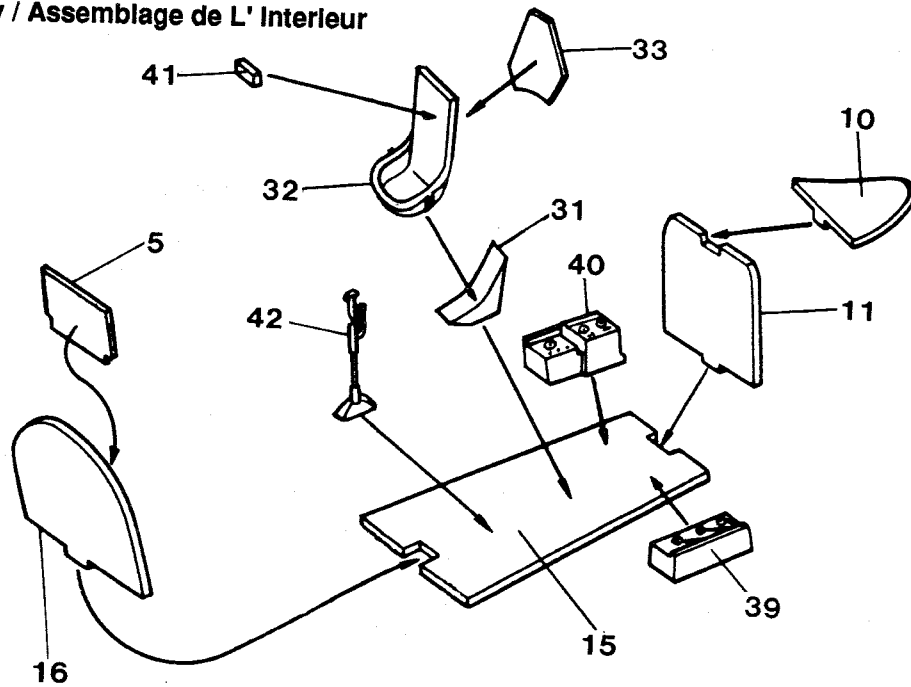

# 2 Fuselage Assembly / Assemblage du Fuselage

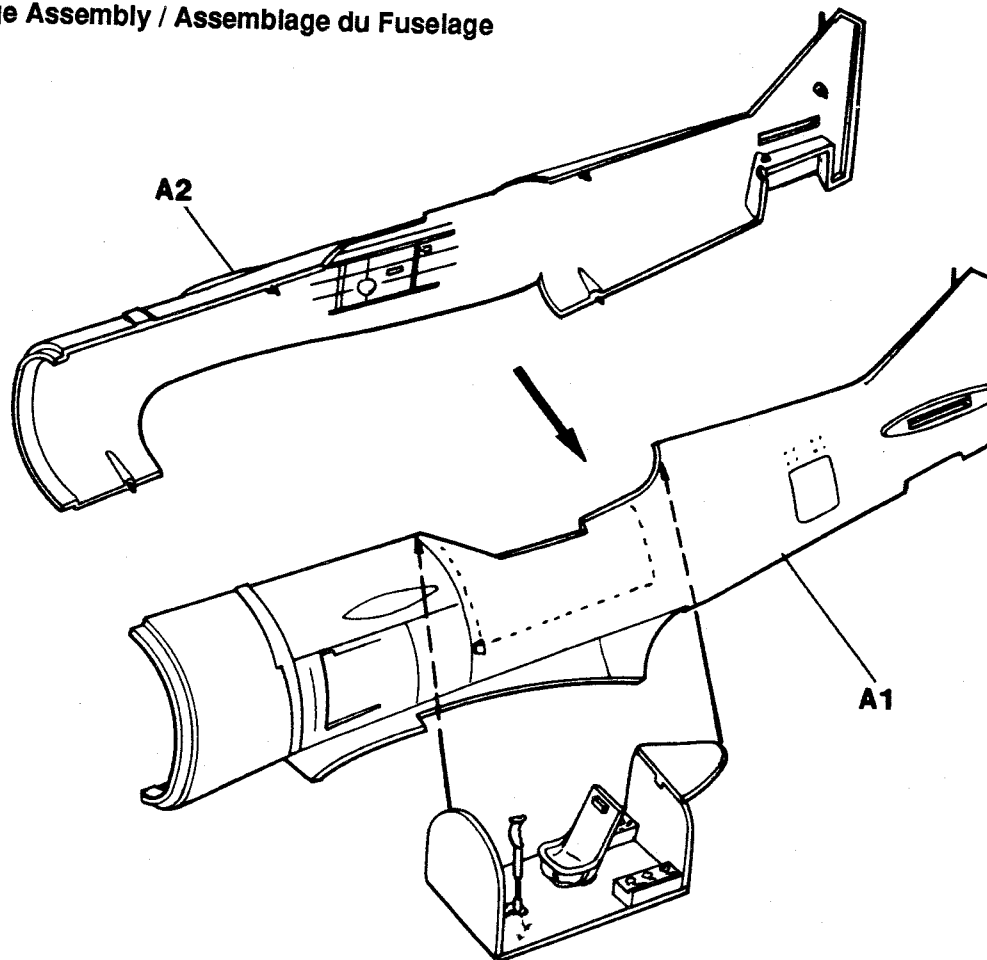

# 3

## Propeller Assembly / Assemblage de Helice

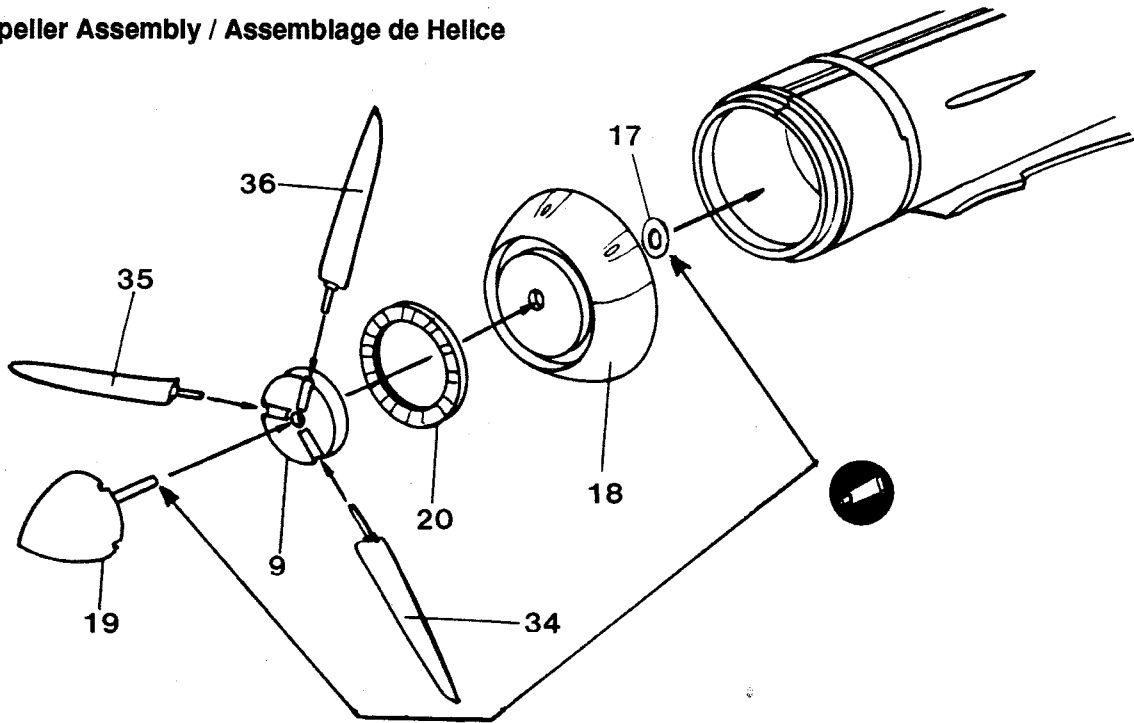

# 4

## Wing & Fuselage Assembly / Assemblage Ailes & Fuselage

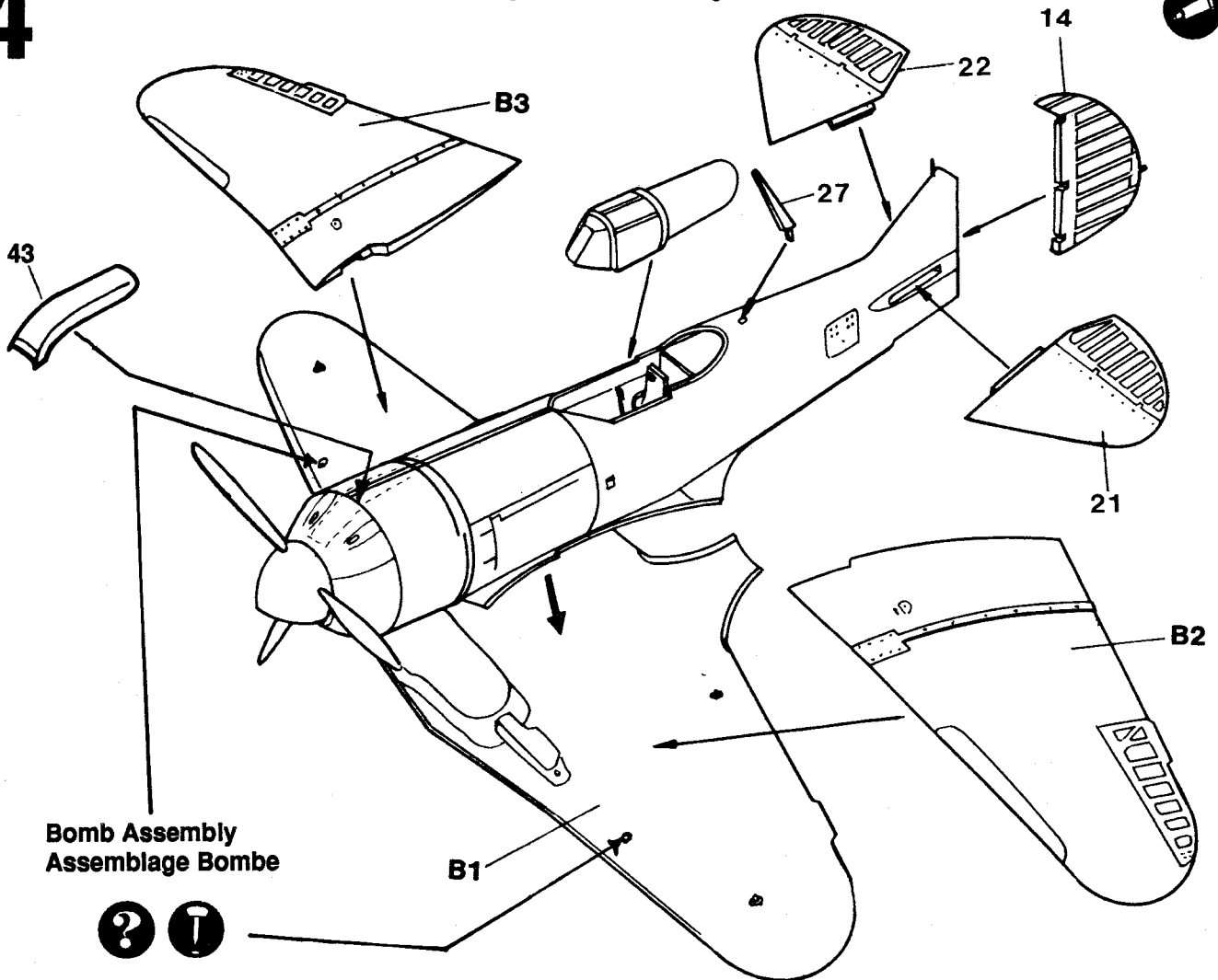

Bomb Assembly  
Assemblage Bombe

# 5 Landing Gear Assembly / Train D' Atterrissage

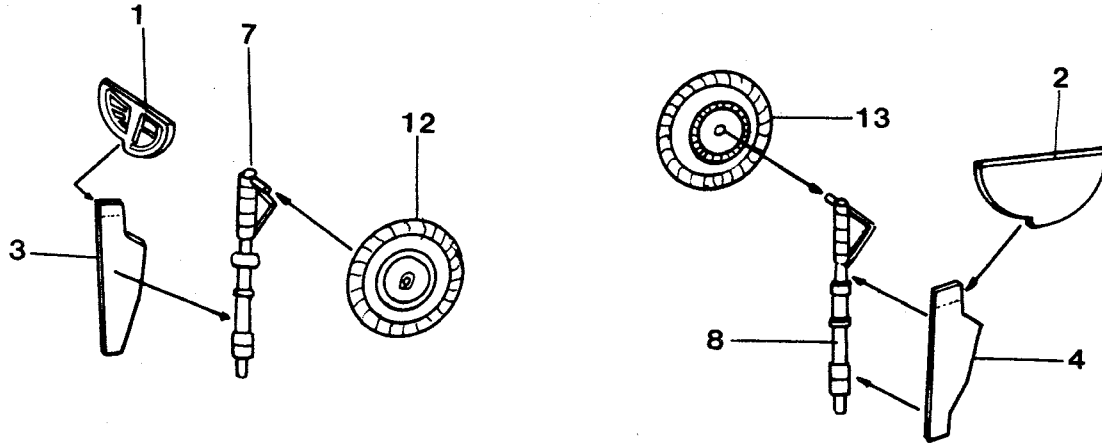

# 6 Landing Gear & Cover Assembly / Train D' Atterrissage & Couvercle

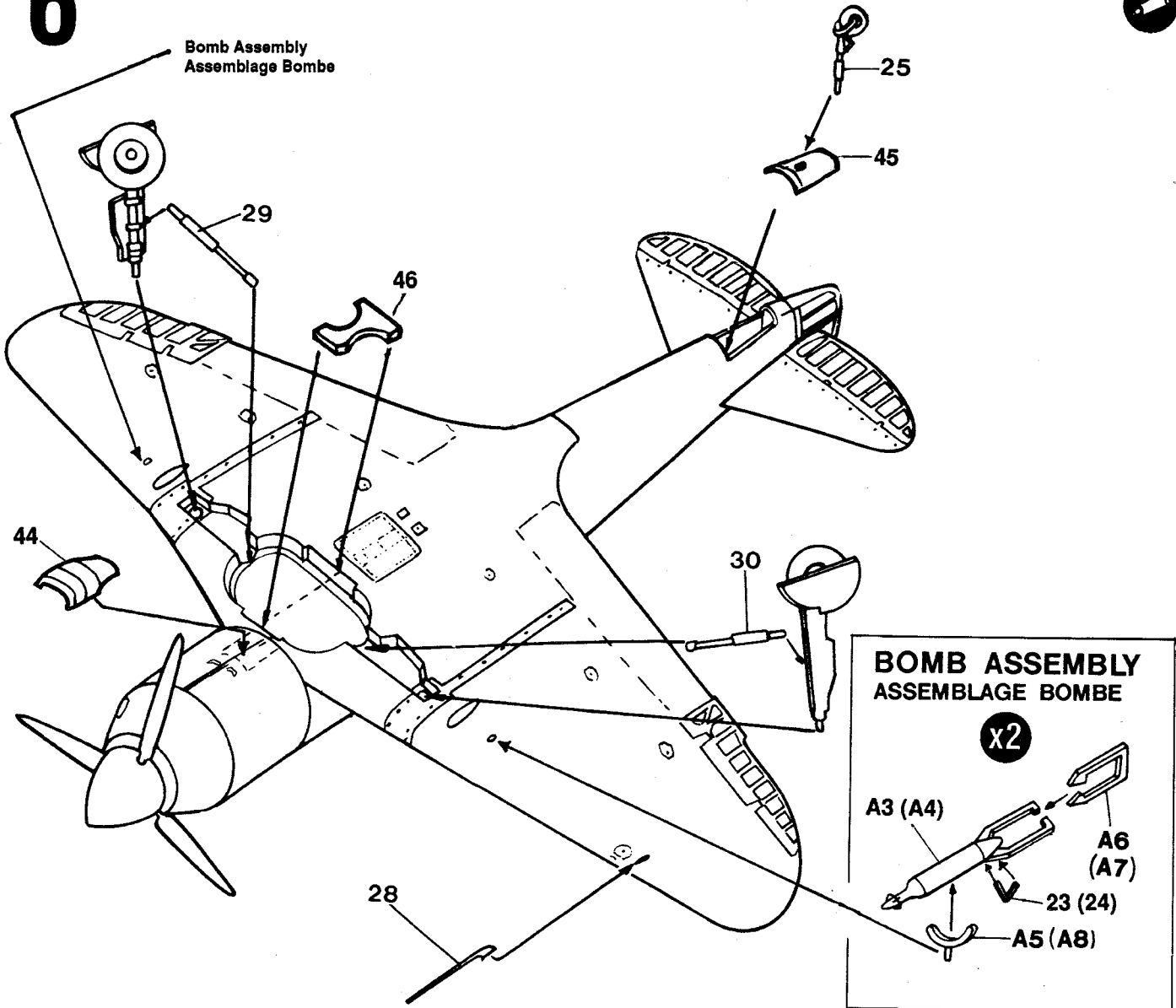

# Camouflage & Markings • Appliques et Couleurs



## I La-5, USSR, V. I. Popkov, 1943

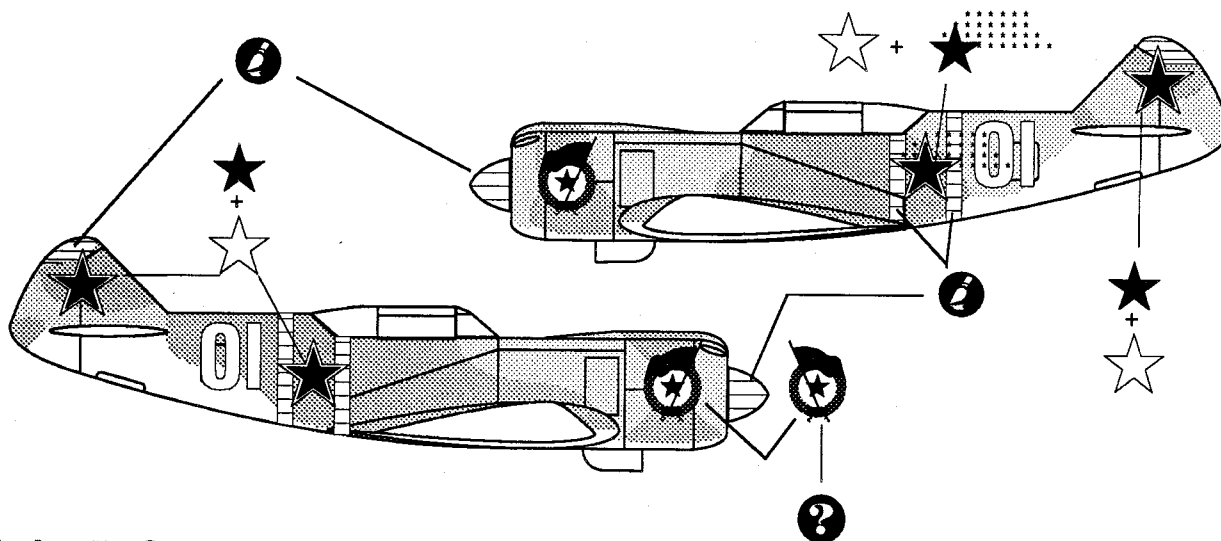

## II La-5, Czechoslovakia, 1946

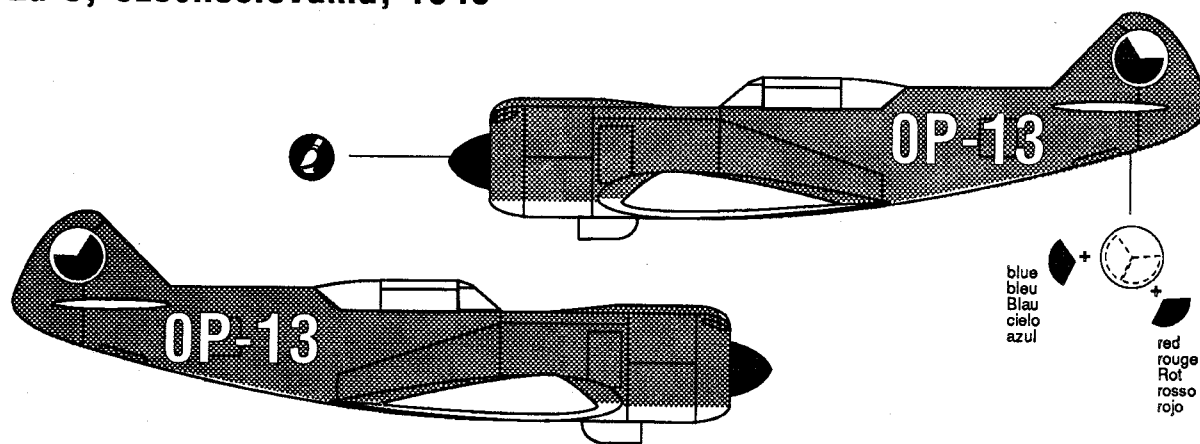

## III La-5, Czechoslovakia-USSR, 1944

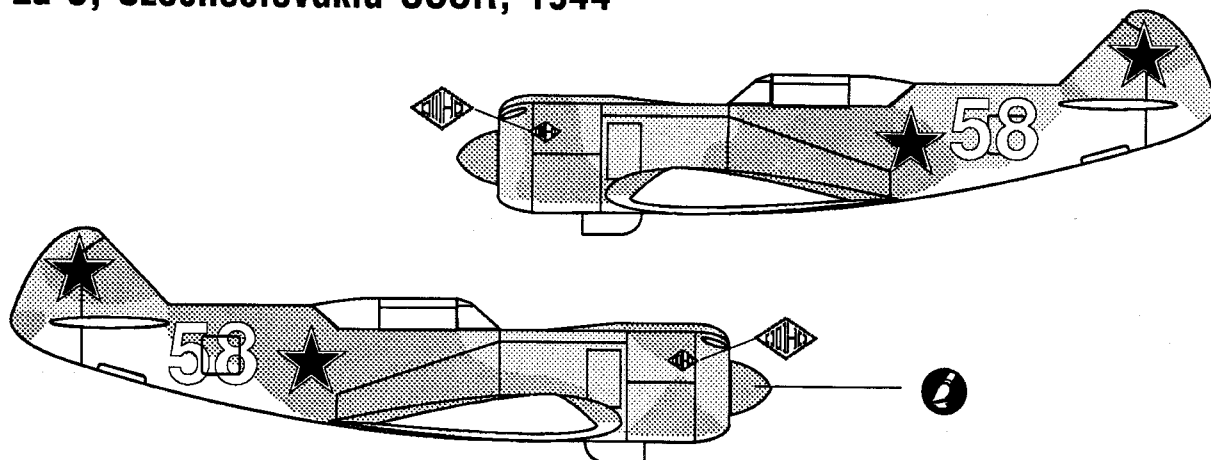

FS 35550

FS 37880

FS 26320

RLM 74

FS 34097

FS 31302

I = III

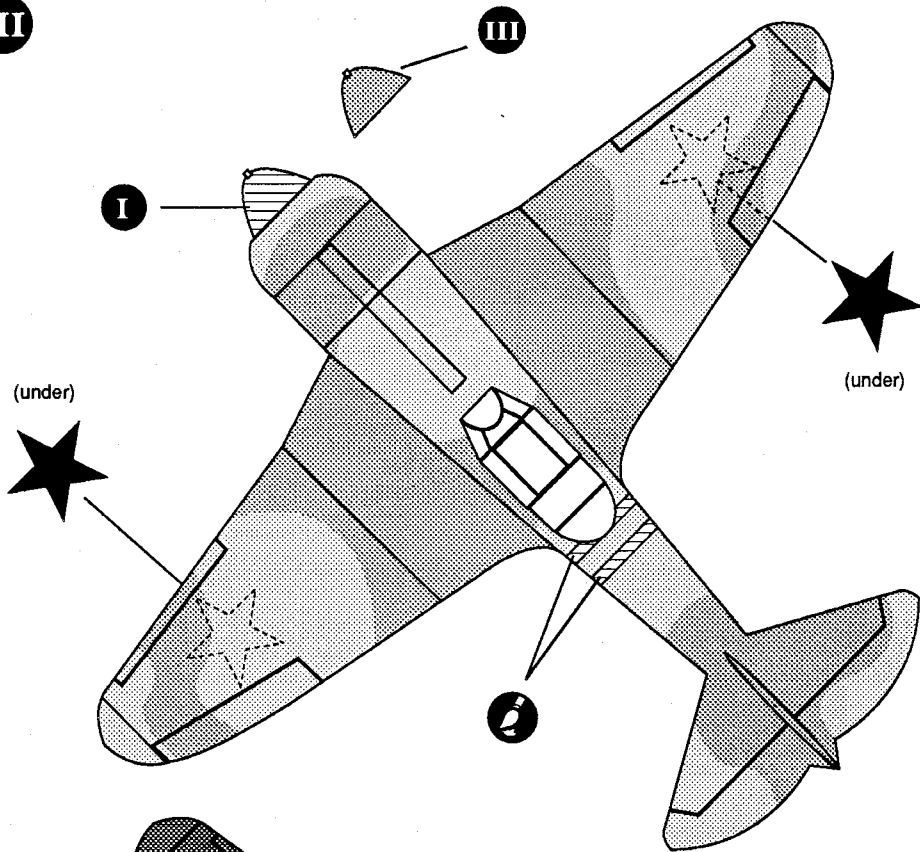

II

