

Fairey Swordfish Mk.I, L9777/701 of No. 814 NAS, HMS Ark Royal, December 1938 to May 1939. Built by Fairey, delivered 15.10.1938. (Ref: Air Brit FAA 1920-39 P.107; FAA C&M Cover)

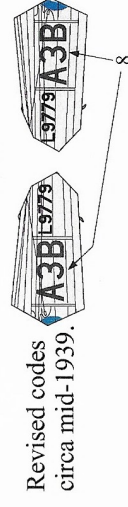

Fairey Swordfish Mk.I: L9779/702 of 814 NAS, HMS Ark Royal, March 1939. Built by Fairey, delivered 21.10.1938. (Ref: Air Brit FAA 1920-39, P.107; FAA C&M Cover)

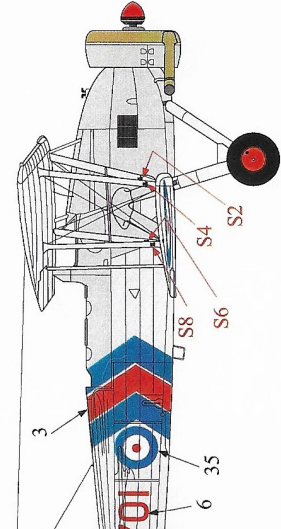
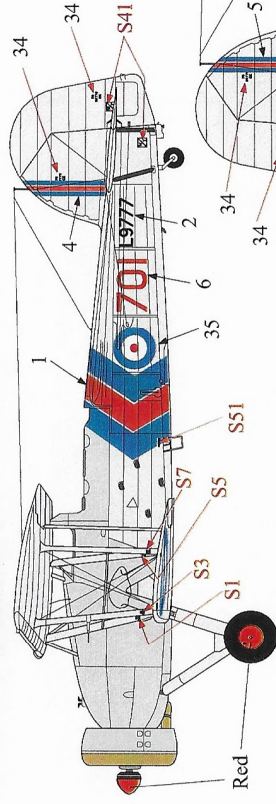
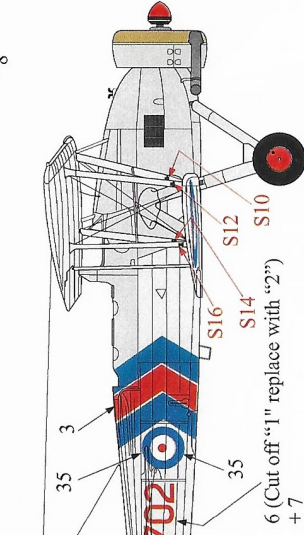
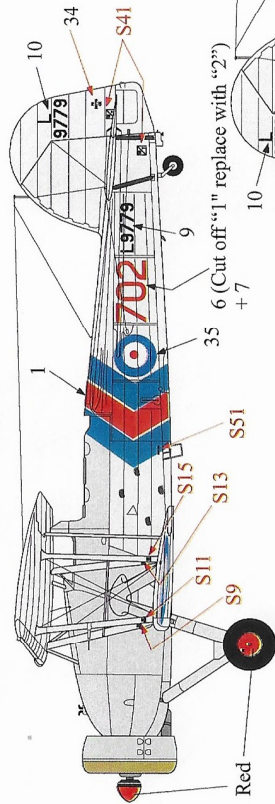

Swordfish Mk.I, P3992/G5K of 825 NAS, HMS Glorious, Summer 1939. Built by Fairey, delivered 1.2.39. (Ref: FAA C&M P49;SAM P.296)

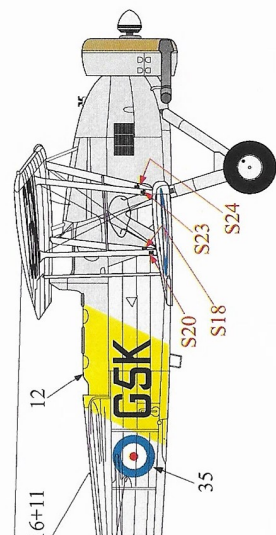
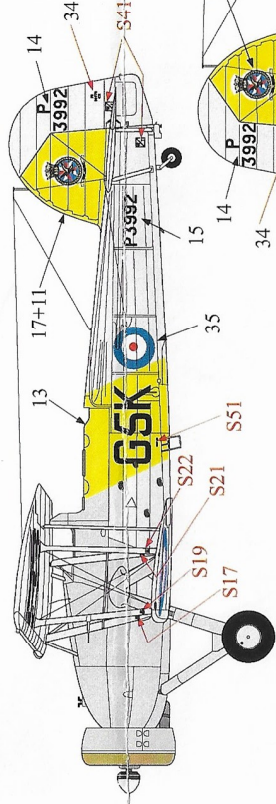

Fairey Swordfish Mk.I, K8393/E5K of No. 824 NAS, HMS Eagle, September 1939. Built by Fairey, delivered 1.12.1936, the aircraft was on strength from January 1937 to 1 November 1939. (Ref: Air Brit FAA 1920-39 P.117).

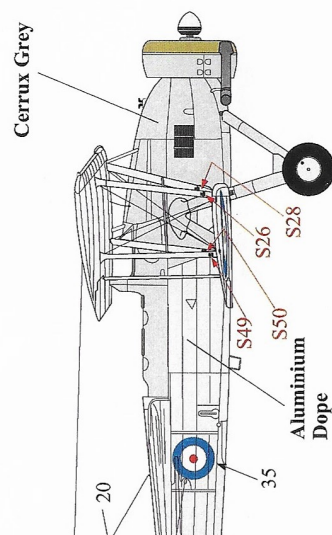
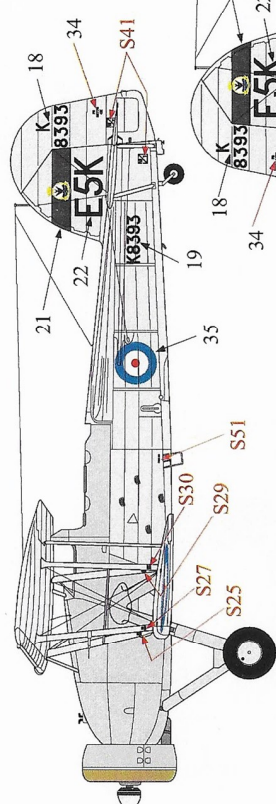

Fairey Swordfish Mk.I, L2732/685 of 821 NAS, HMS Courageous in 1938. Delivered 2.7.37. (Ref: Ray Sturtivant foto)

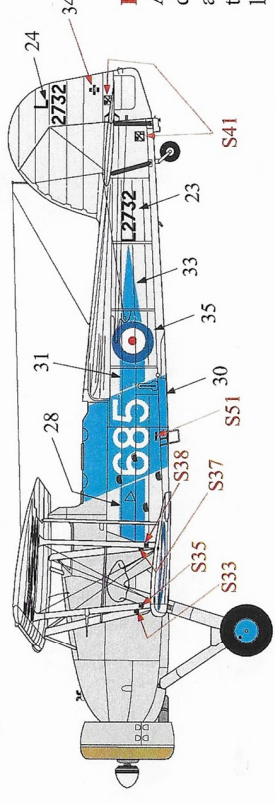

Pre-war finish

Aircraft were delivered with fabric areas in Aluminium dope and metal fuselage panels in Cerrux Grey. This also applied to the cowling, however, most photographs show this as a darker colour - heat discoloration? Undercarriage legs were probably also Cerrux Grey.

Fairey Swordfish Mk.I, L.2826/2P of 810 NAS, HMS Ark Royal in 1941. L.2826 was built by Fairey, delivered on 1.12.1937 and was with the squadron from March 1940 to March 1941. (Ref: Ray Sturttivant foto).

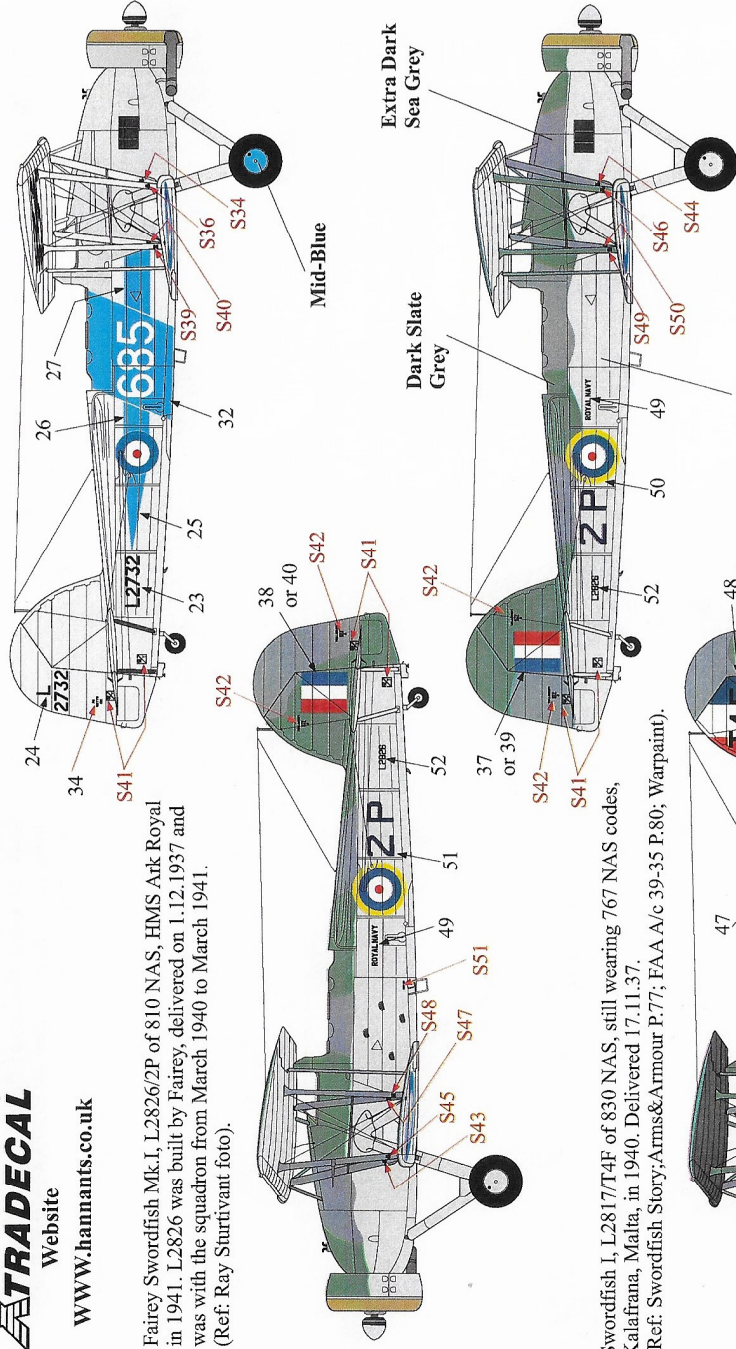

Swordfish I, L2817/4F of 830 NAS, still wearing 767 NAS codes, Kalafrana, Malta, in 1940. Delivered 17.11.37. (Ref: Swordfish Story:Arms&Armour P.77; FAA A/c 39-35 P.80; Warpaint).

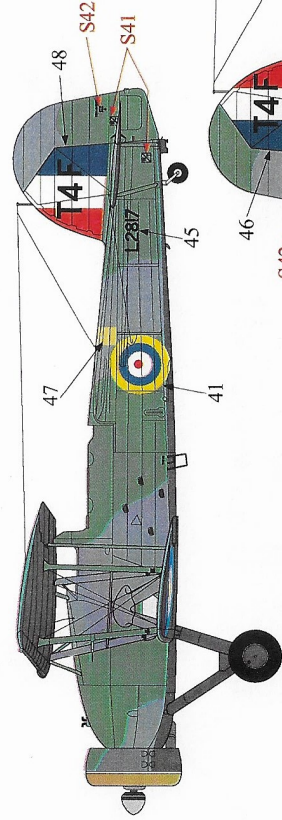

Fairey Swordfish Mk.I, V4298/4C of No 820 NAS, HMS Ark Royal. Damaged in the attack on the Bismark 26 May 1941; Pilot and TAG wounded (S/Lt F A Swanton and L/A J R Seager), the Observer Gerard Woods was unharmed. (Ref: FAA C&M Lloyd P.103)

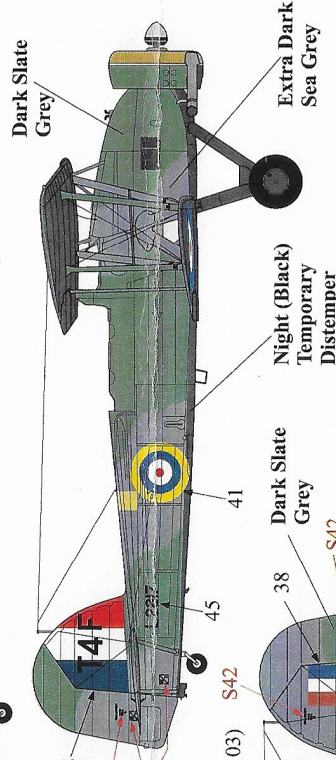

Extra Dark Sea Grey

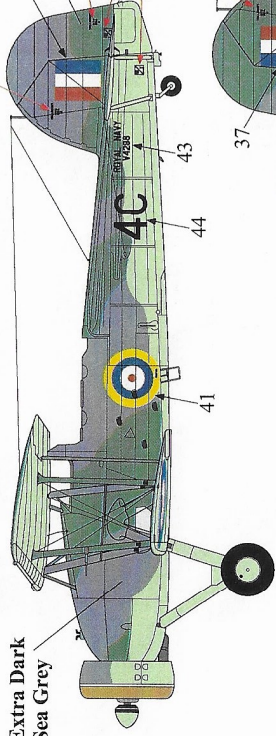

Extra Dark Sea Grey

Swordfish Mk.I, V4378/L9-S of 781 Sqn., RNAS Le-on-Solent, circa Sept 1942 to April 1944. Built by Blackburn, delivered 26.4.41. (Ref:SAM Apr 84 P.299; R Sturttivant Pic)

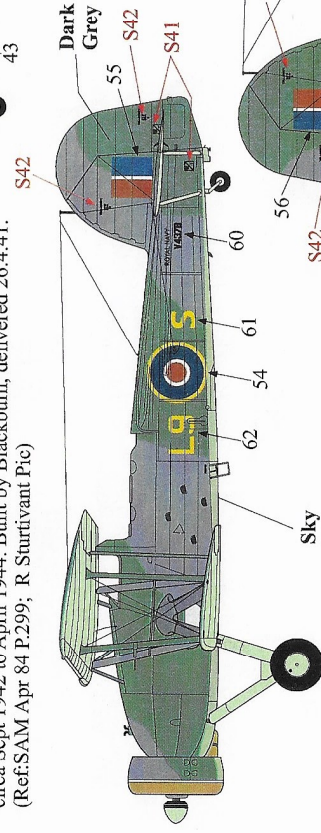

Sky

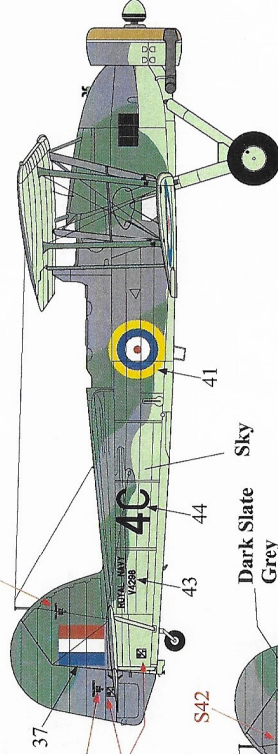

Extra Dark Sea Grey

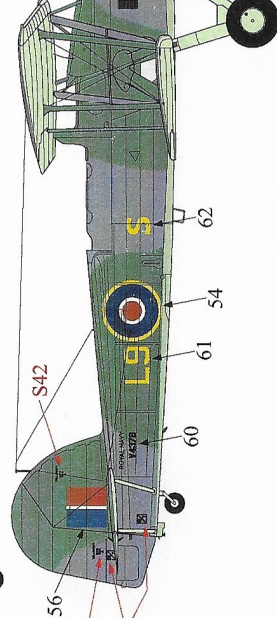

Note:
Use L2826 as a guide for placement of decals 43 to 50 on L2817, V4298, V4378, V4515 and LS348

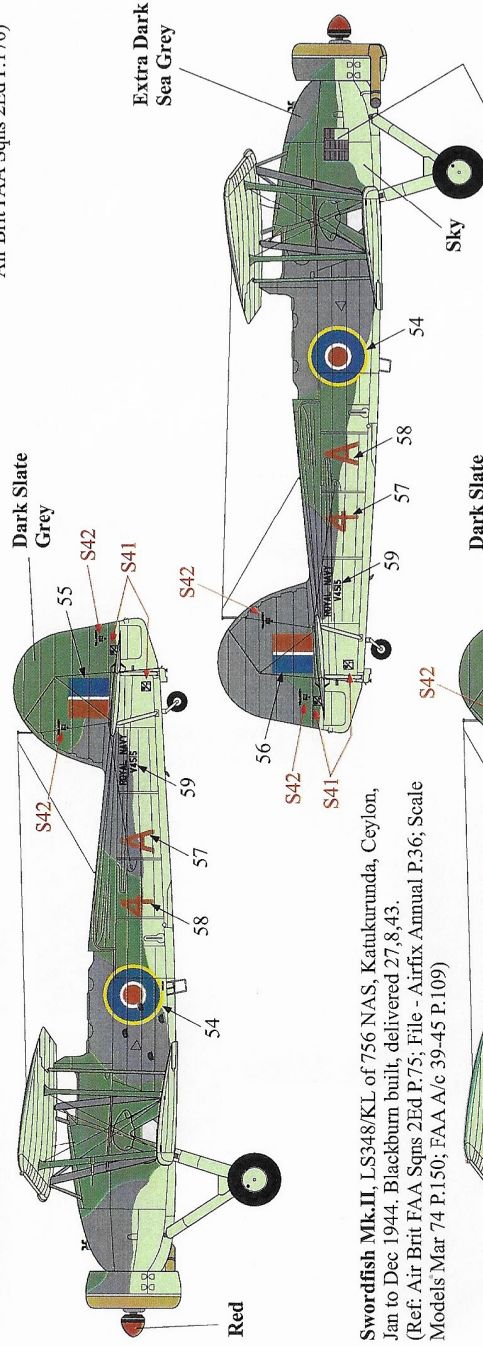

Swordfish Mk.II, LS348/KL of 756 NAS, Katukurunda, Ceylon,
Jan to Dec 1944. Blackburn built, delivered 27.8.43.
(Ref: Air Brit FAA Sqns 2Ed P.75; File - Airfix Annual P.36; Scale
Models: Mar 74 P.150; FAA A/c 39-45 P.109)

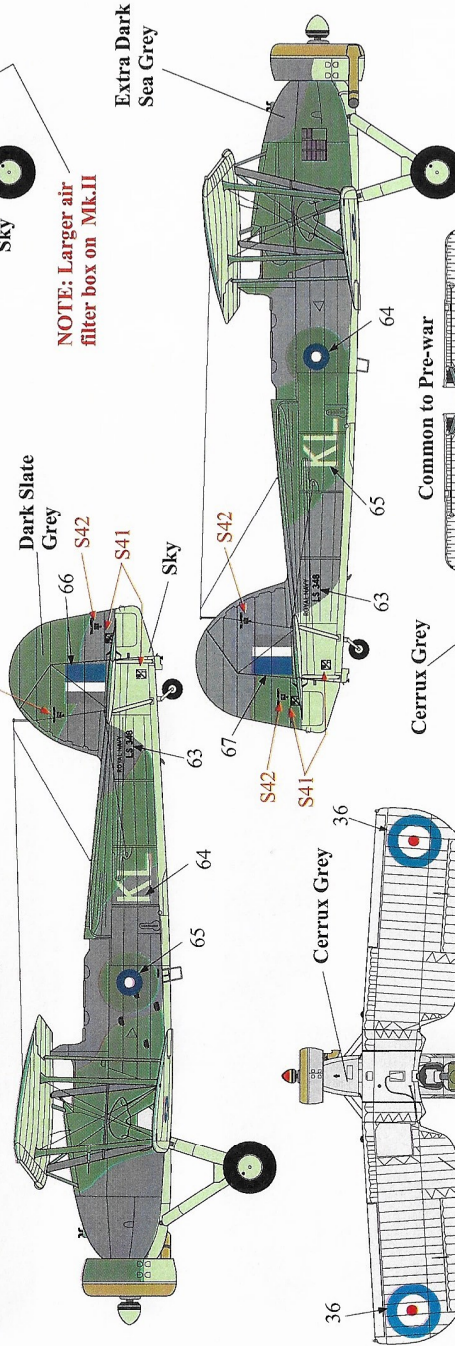

Aluminium
Dope

K8393
L2732
L9777
L9779
P3992

Cerrux Grey

Common to Pre-war

Matt Black

Aluminium
Dope

P3992

18

Decal 34
Use this plan to
position on
K8393, L2732, L9777,
L9779 and P3992.

Lower Wing

L2817 and L2826

Light Slate
Grey

Dark
Sea Grey

Dark Slate
Grey

Extra Dark
Sea Grey

42

L2817

Decal S42
Use this plan to
position on
L2817, L2826,
V4298, V4378,
V4515 and LS348

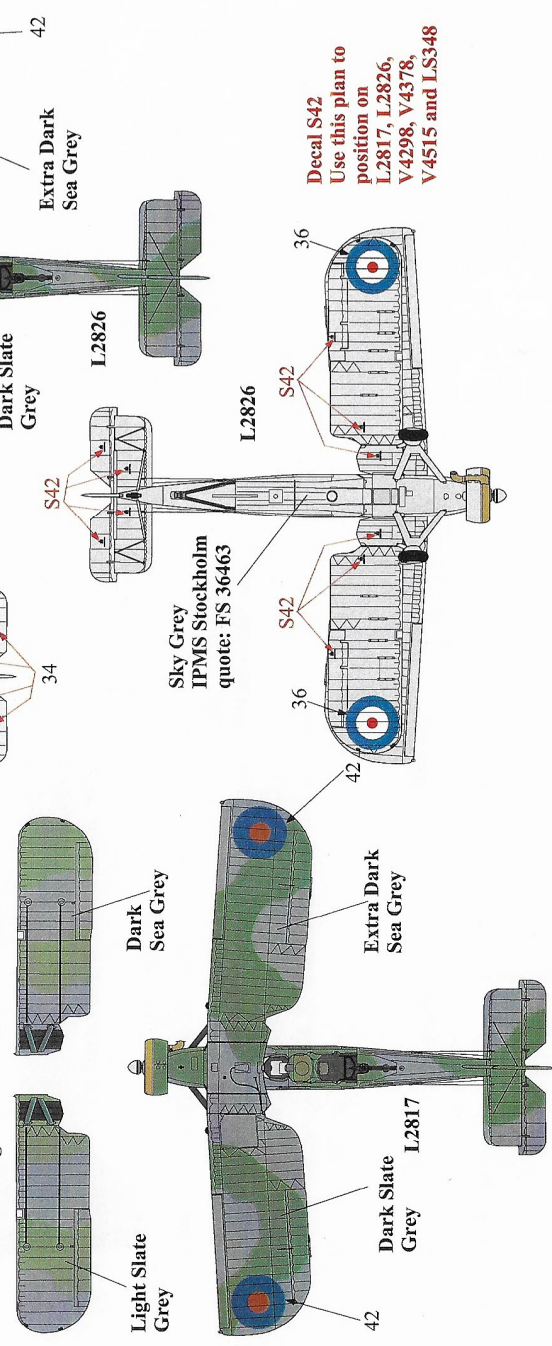

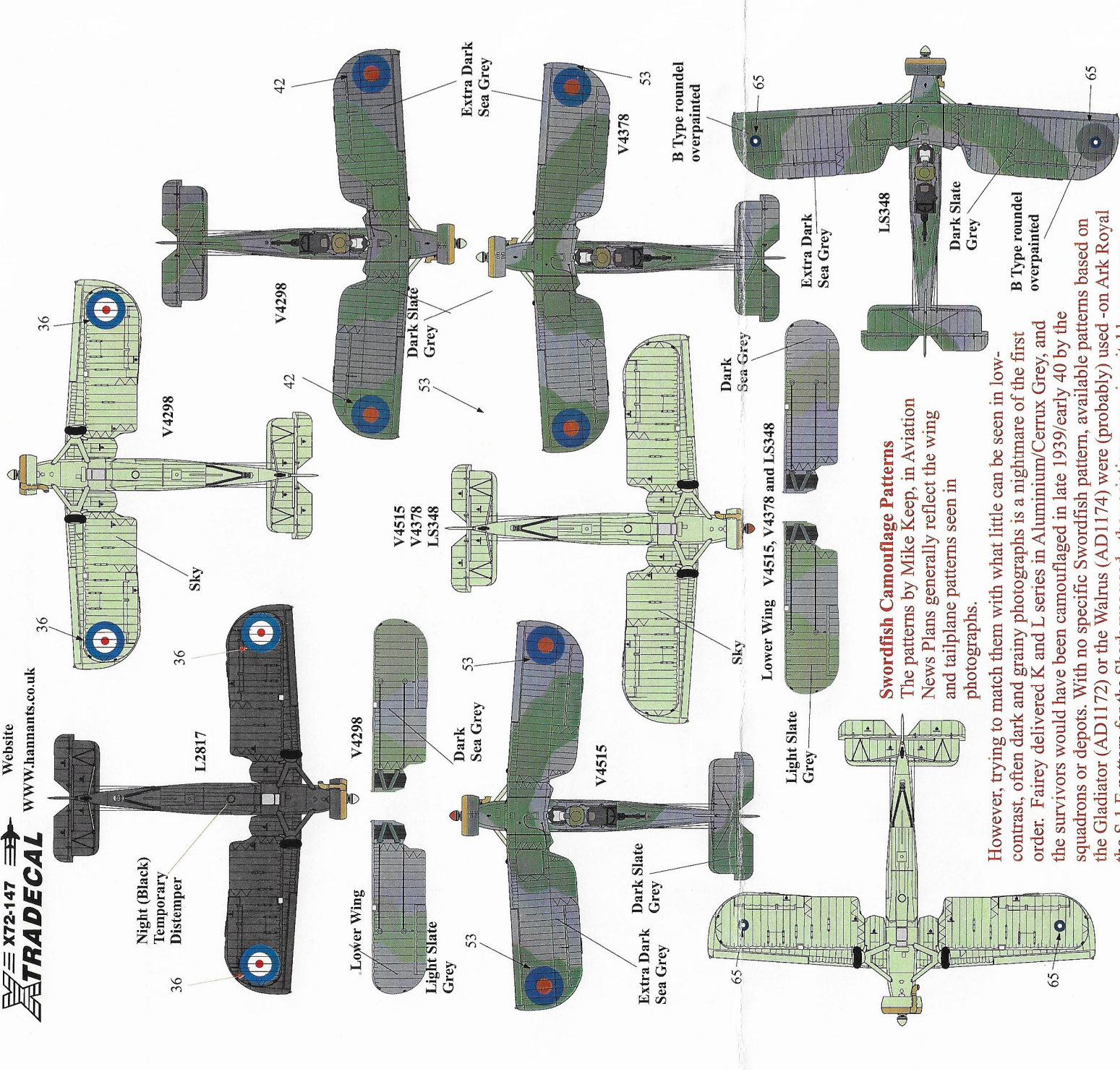

Swordfish Camouflage Patterns

The patterns by Mike Keep, in Aviation News Plans generally reflect the wing and tailplane patterns seen in photographs.

However, trying to match them with what little can be seen in low-contrast, often dark and grainy photographs is a nightmare of the first order. Fairey delivered K and L series in Aluminium/Cerrux Grey, and the survivors would have been camouflaged in late 1939/early 40 by the squadrons or depots. With no specific Swordfish pattern, available patterns based on the Gladiator (AD1172) or the Walrus (AD1174) were (probably) used - on Ark Royal the S.1.E pattern for the Shark was used - the variations were inevitably numerous..

Fairey produced the P series and Blackburn all subsequent production from V4288 onwards, for which patterns must have been produced - but, examples do not appear to have appeared in the modelling press. Mike Keep produced 3 patterns, A, B and Combined (used from circa March 1941). Did even numbers use A and uneven numbers B pattern?. Comments in Ian Huntley's article in SAM on the restoration of the FAA Historic Flight's LS326, quote Fairey Drawing B37609 with the comment "Blackburn late build copied final Fairey drawing with slight variations. With shadow shading.

Every effort has been taken to match the plan/side views, however, they are at best "For guidance only" and no claims regarding accuracy is made.

Xtracolor Paints:

Dark Sea Grey BS638
Extra Dark Sea Grey BS640
Sky BS210
Night BS642
Dark Slate Grey
Light Slate Grey
High Speed Silver
Sky Grey
Aluminium

Xtracrylix Paints:

Dark Sea Grey BS638 XA1004
Extra Dark Sea Grey BS640 XA1005
Sky BS210 XA1007
Night BS642 XA1012
Dark Slate Grey BS634 XA1025
Light Slate Grey XA1037
RLM Silber XA1216

Reference:

**Dalrymple & Verdun book
FAA Camouflage & Markings
by Stuart Lloyd**