

# B-34 Lexington



The B-34 evolved from earlier twin engine aircraft designed by Lockheed in the 1930's. This aircraft was used by both the United States Army Air Force and the United States Navy. The U.S. Army used early versions of the airplane until adequate quantities of more effective aircraft could be developed. The Ventura was also supplied to key allies including British Commonwealth member nations Canada and South Africa.

This kit offers an all new USAAF B-34 markings printed by Cartograf. The 2 new marking options represent 2 United States Army Air force B-34's. The first represents an early bomber originally ordered by the Royal Air Force but diverted to the U.S. Army Air Force after the U.S. entered World War II. The second marking scheme represents a B-34 used for crew training. The model features engine detail, rotating propellers and position-able landing gear.

Marking included in this kit are:

USAAF B-34 Lexington (Ventura II), RAF AJ288, ca. 1942  
USAAF RB-34 Lexington, 41-38165, Randolph Field, TX, 1942

Minicraft Models, 1501 Commerce Drive, Elgin IL 60123 USA  
[www.minicraftmodels.com](http://www.minicraftmodels.com)

Printed in China

11672

# PARTS LOCATING DIAGRAM

## SPRUE A

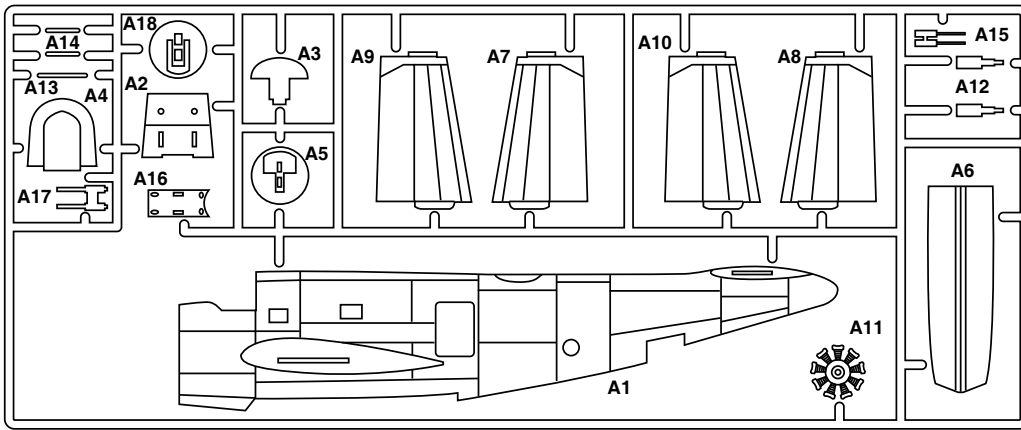

## CLEAR SPRUE E

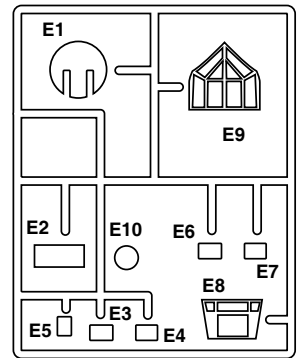

## SPRUE B

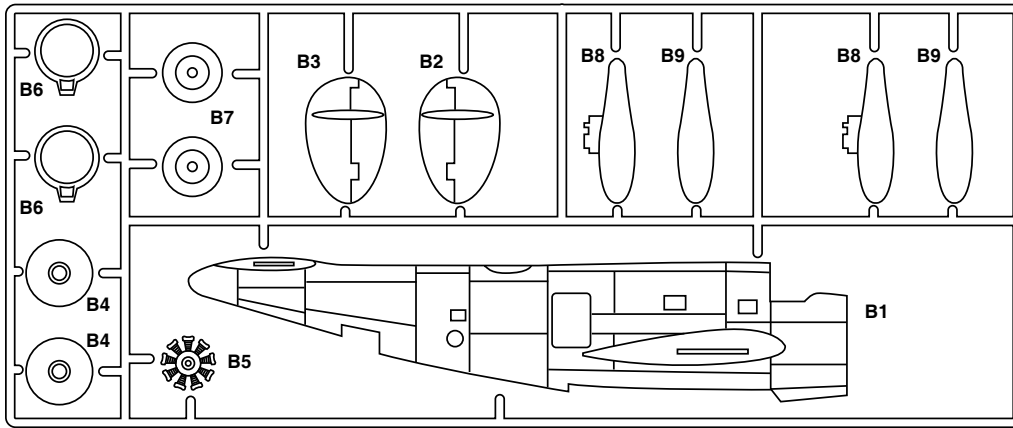

## CLEAR SPRUE E

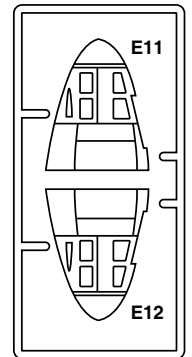

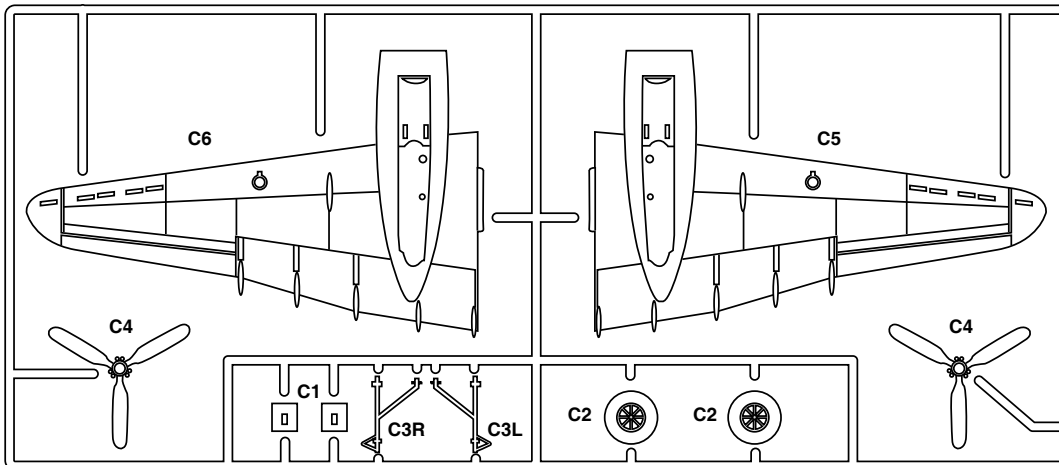

## SPRUE C



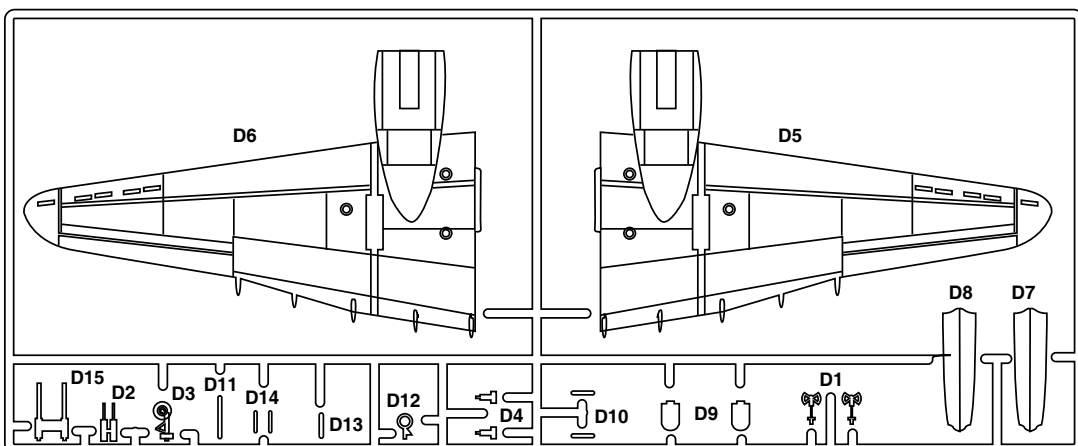

Note: All parts may not be used in assembling this kit.

## SPRUE D





- 

Cement  
Coller  
Kleben  
Pegar  
Incollare  
Colar  
Kleven
- 

DO NOT Cement  
Ne pas Coller  
Nicht Kleben  
No Pegar  
Non Incollare  
Nao Colar  
Niet Kleven
- 

Cut away  
Couper  
Scheiden  
Cortar  
Tagliere  
Cortar  
Snijden
- 

Optional parts  
Choix  
Auswahlmöglichkeit  
Eleccion  
Scelta  
Opaco  
Keuze
- 

3  
Repeat operation  
Rzpeeter l' opzration  
Vorgang wiederholen  
Repitir la operacion  
Ripetere  
Repitir a operacao  
Herhalen
- 

Symmetrical assembly
- 

Drill hole

# 1 INTERIOR / TURRET

 All Parts

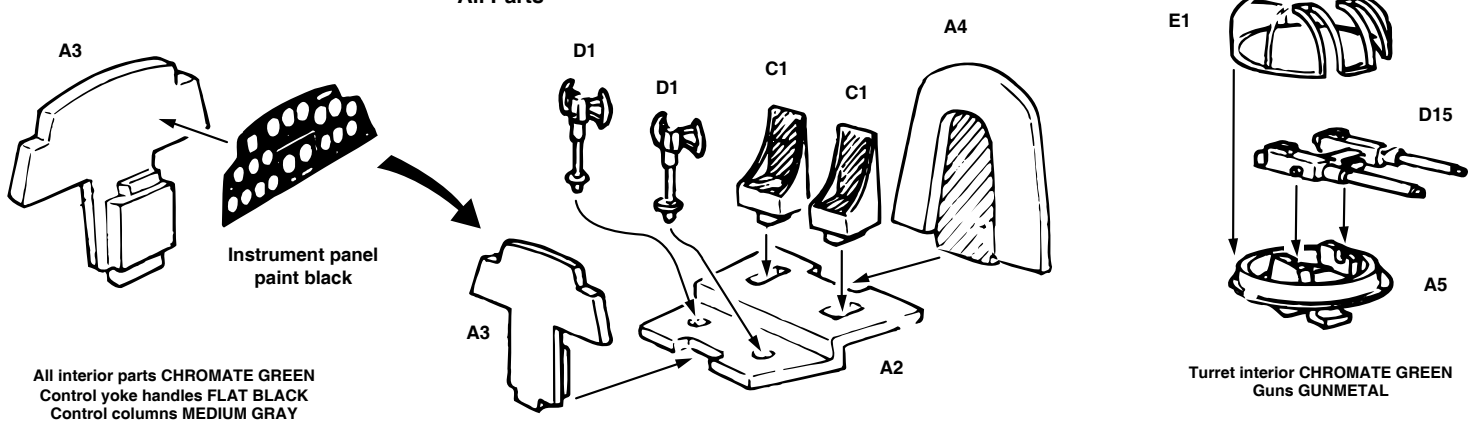

# 2 COCKPIT AND TURRET INSTALLATION

**NOTE**

Fill in engraved panels as shown in Gray before assembly

E11

E12

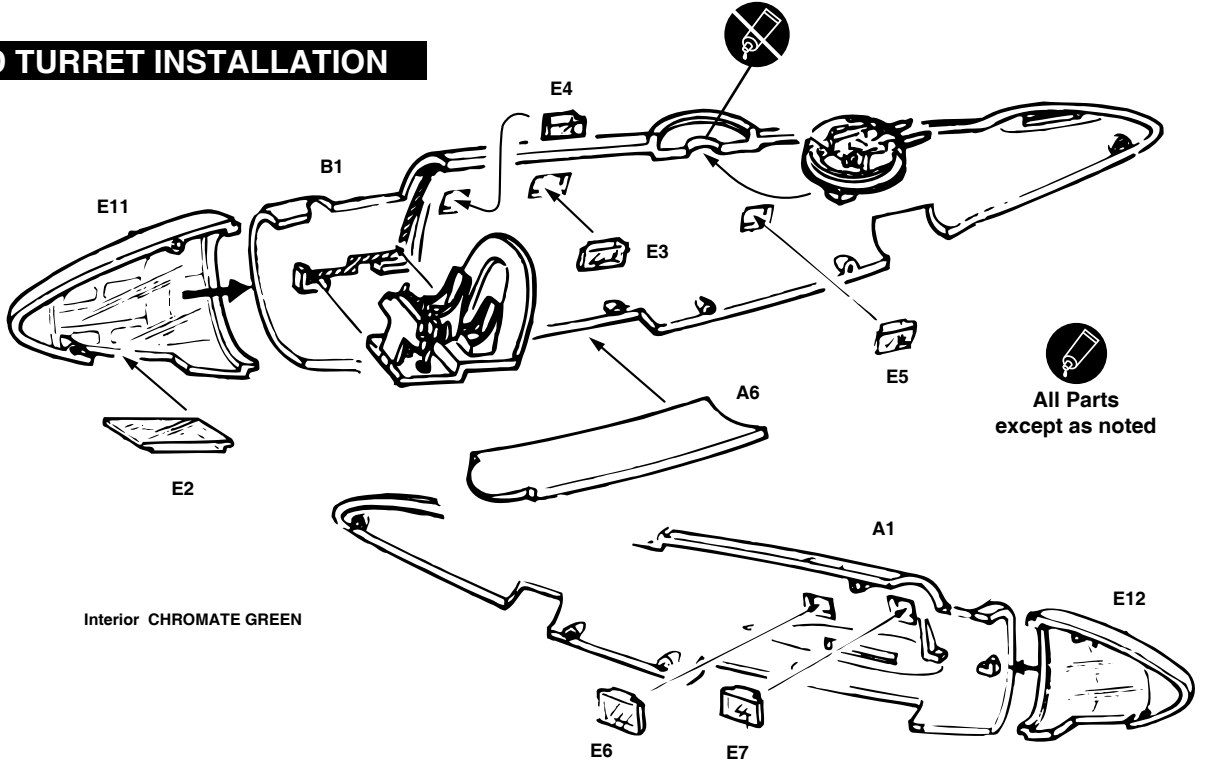

# 3 FUSELAGE ASSEMBLY

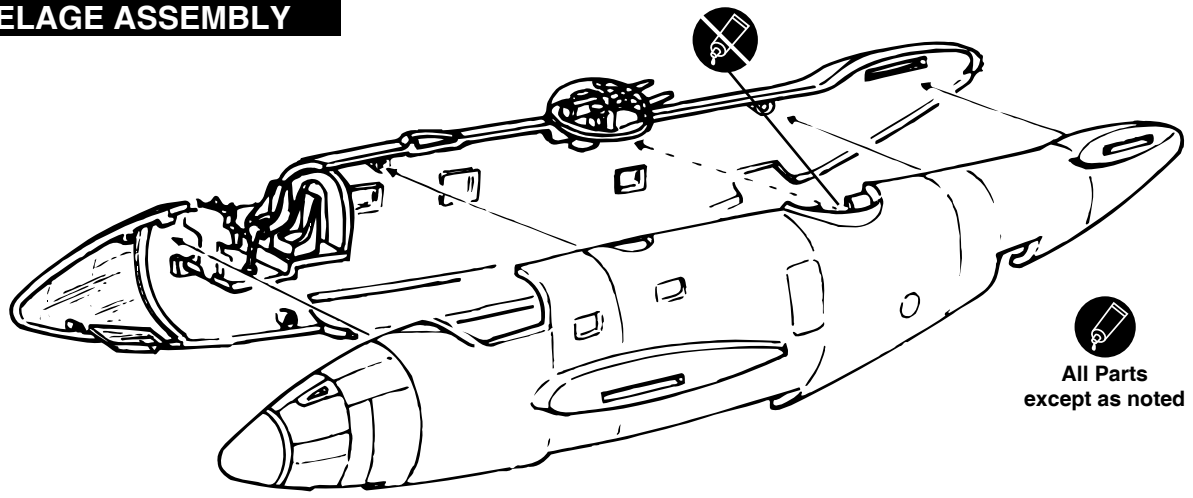

# 4 CANOPY INSTALLATION



All Parts

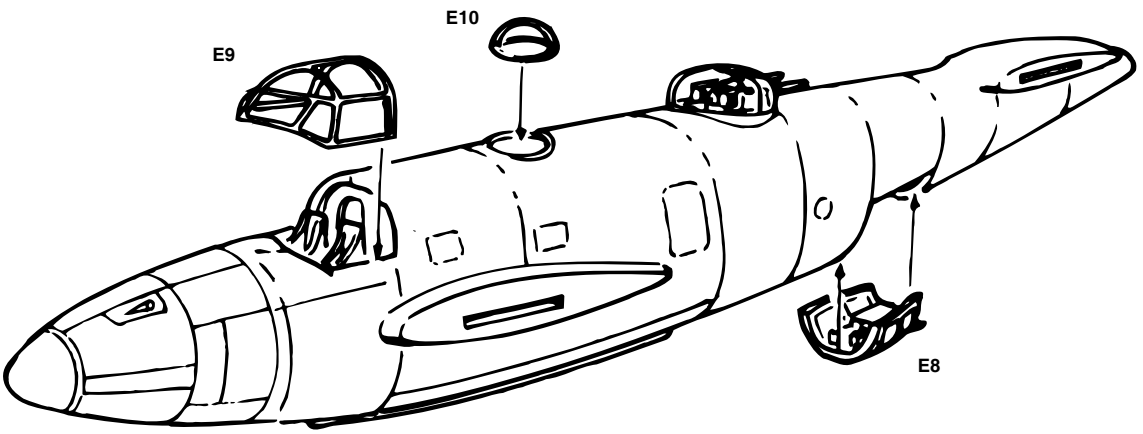

# 5 TAIL ASSEMBLY



All Parts

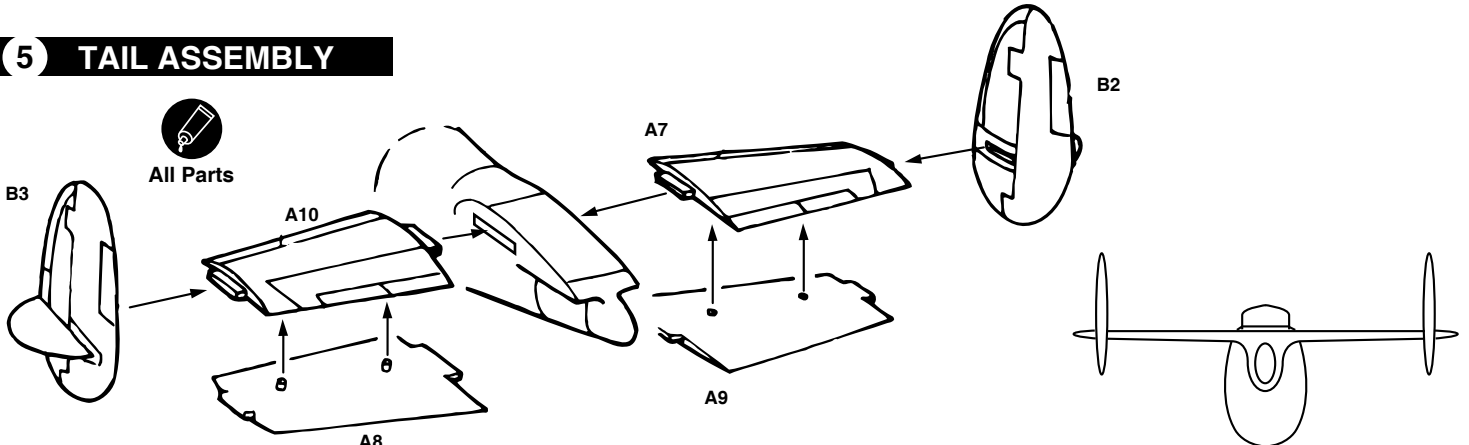

Note alignment

# 6 ENGINE ASSEMBLY



All Parts except as noted

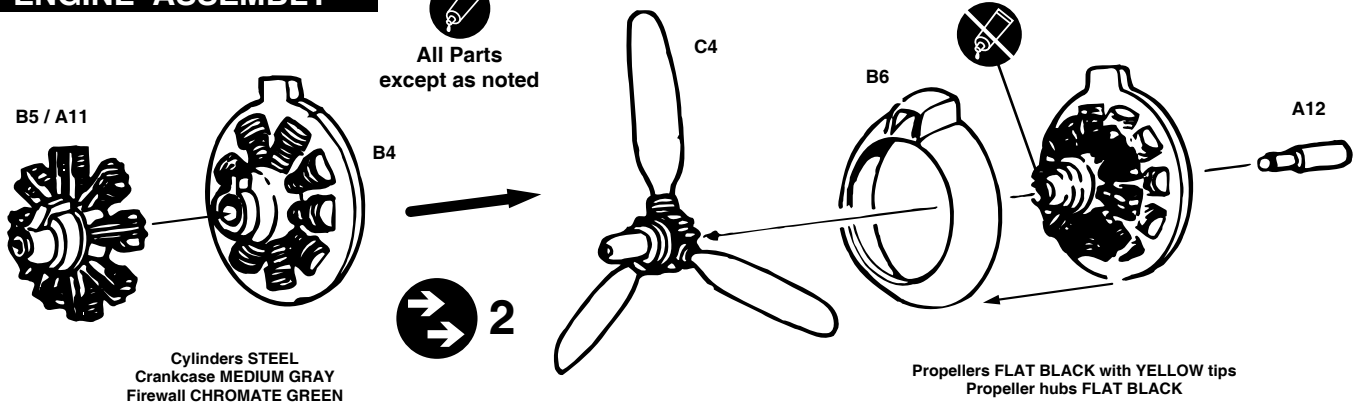

Cylinders STEEL  
Crankcase MEDIUM GRAY  
Firewall CHROMATE GREEN

Propellers FLAT BLACK with YELLOW tips  
Propeller hubs FLAT BLACK

# 7 MAIN LANDING GEAR



All Parts

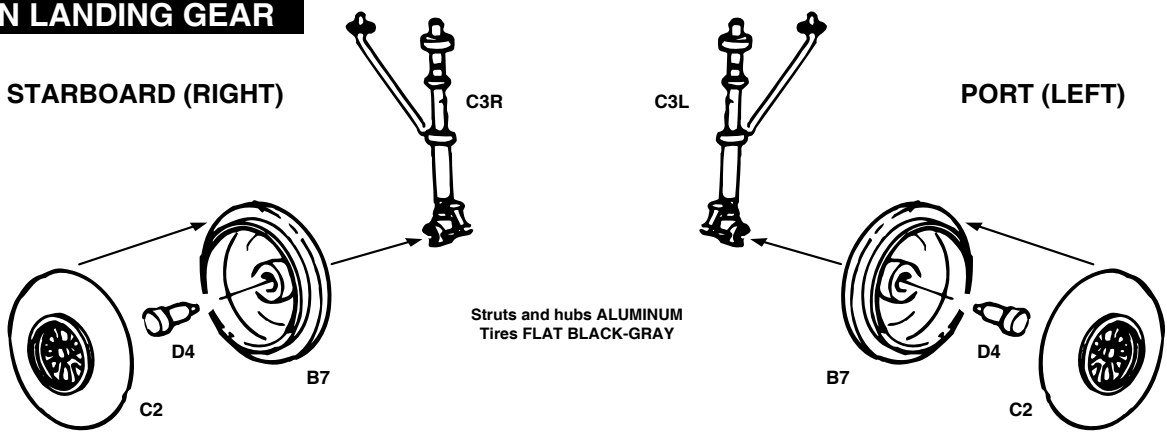

Struts and hubs ALUMINUM  
Tires FLAT BLACK-GRAY

## 8 PORT (LEFT) WING ASSEMBLY

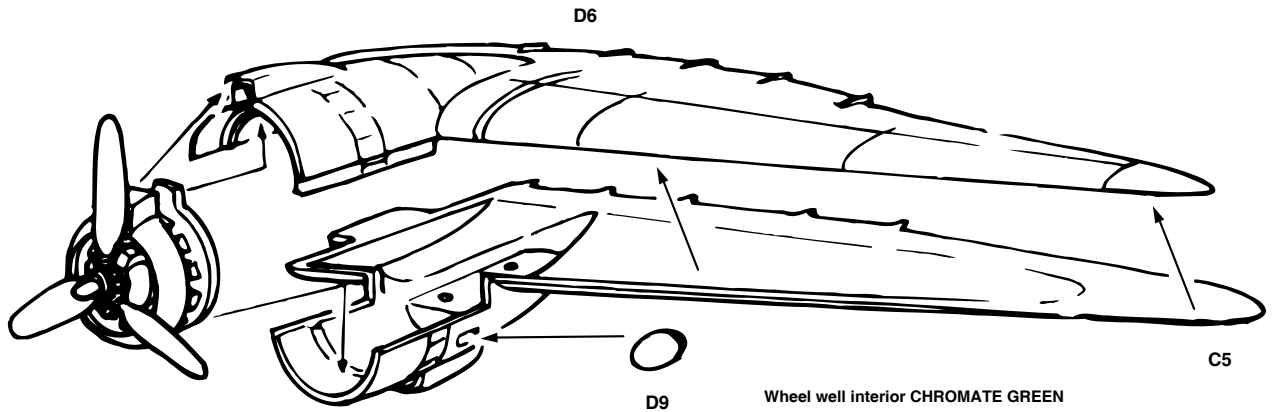

## 9 STARBOARD (RIGHT) WING ASSEMBLY

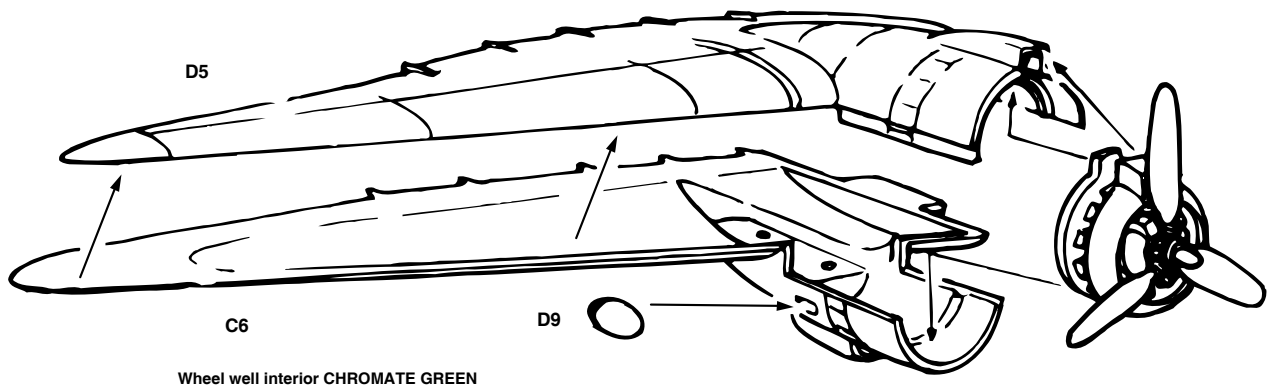

## 10 WING INSTALLATION

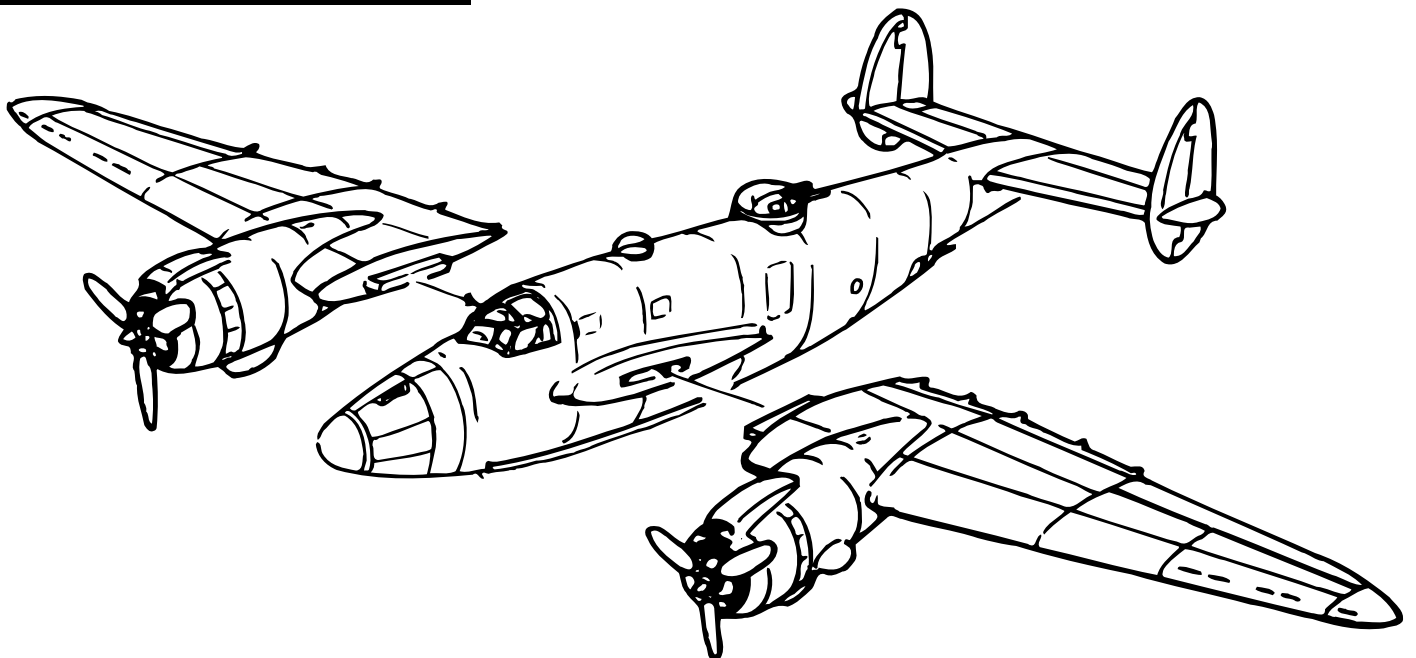

# 11 LANDING GEAR INSTALLATION

**EXTENDED MAIN GEAR**

Cut parts D7/D8 in half as shown

Gear door interiors CHROMATE GREEN  
Tailwheel strut ALUMINUM  
Tire FLAT BLACK-GRAY

**All Parts**

**RETRACTED MAIN GEAR OPTION**

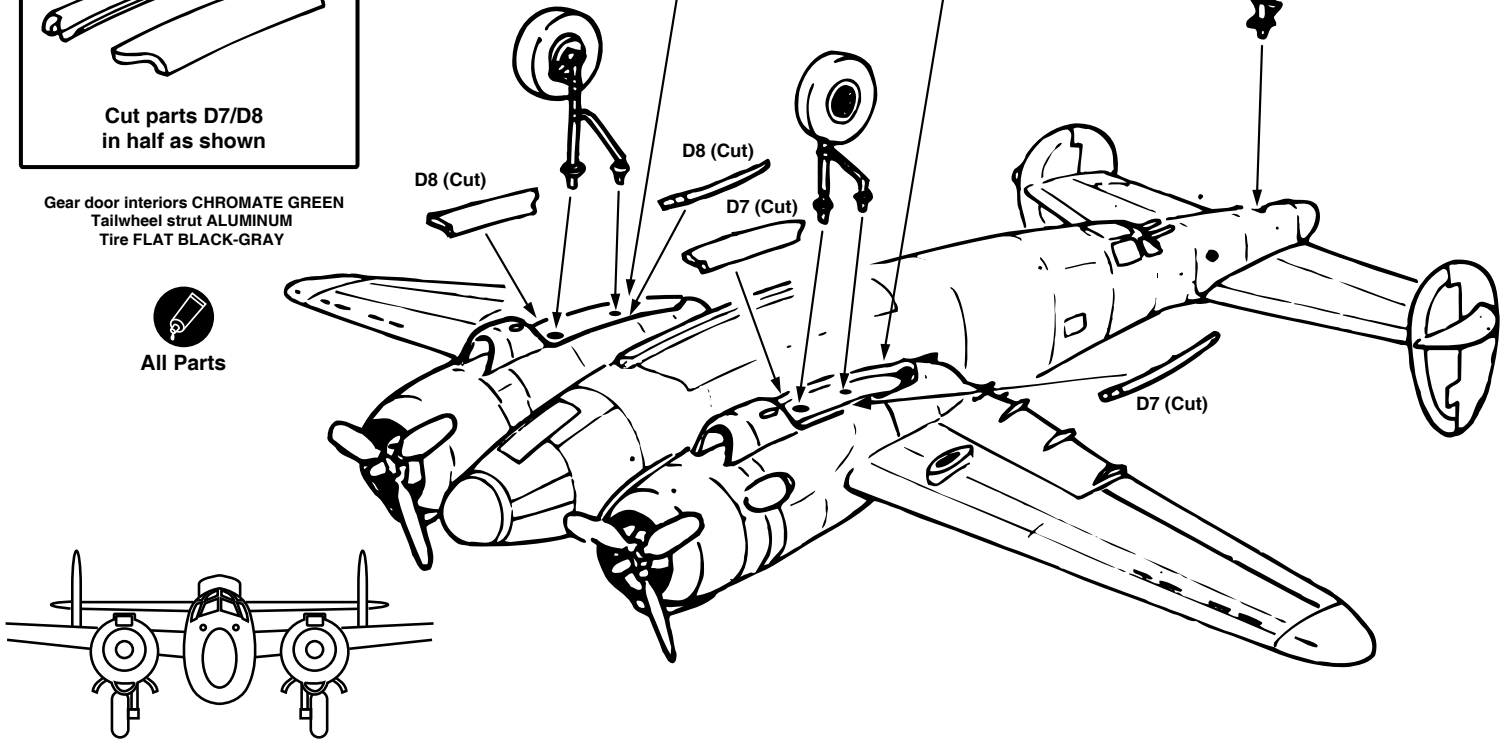

Note alignment

# 12 FINAL ASSEMBLY

**All Parts**

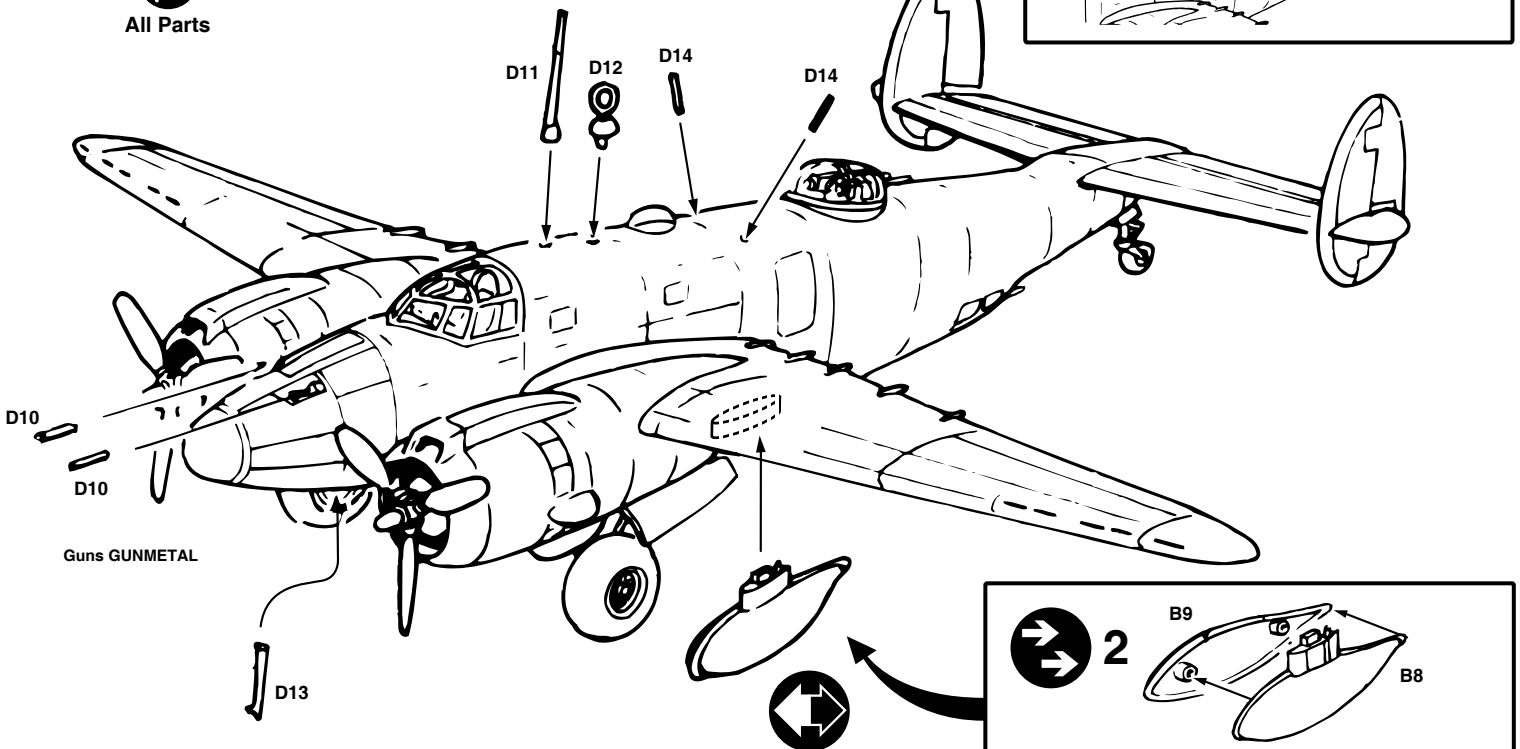
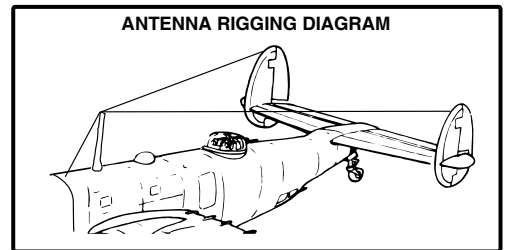

Guns GUNMETAL

# USAAF B-34 Lexington (Ventura II), RAF AJ288, ca. 1942

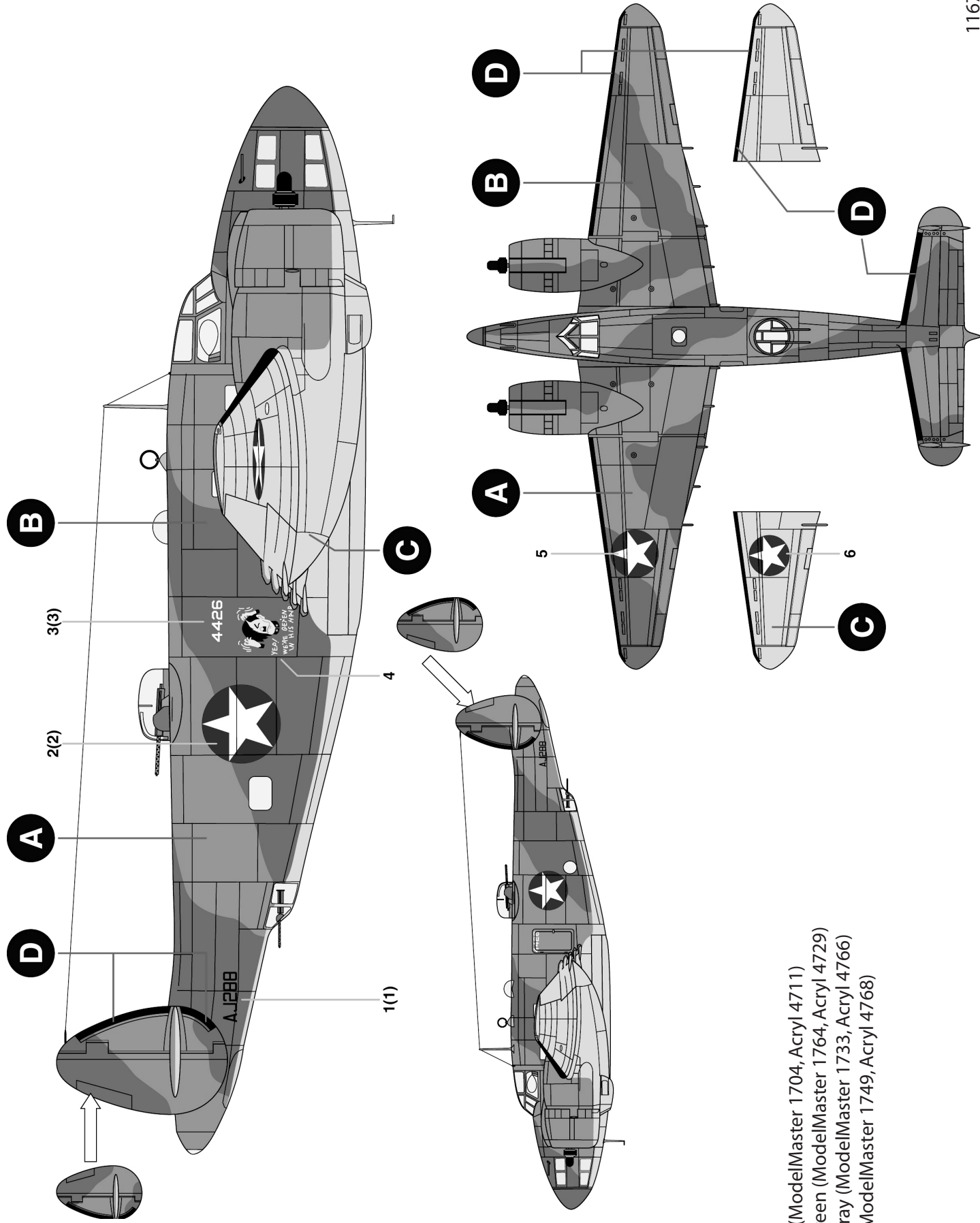

## PAINTS

- A Brown (ModelMaster 1704, Acryl 4711)
- B Dark Green (ModelMaster 1764, Acryl 4729)
- C Light Gray (ModelMaster 1733, Acryl 4766)
- D Black (ModelMaster 1749, Acryl 4768)

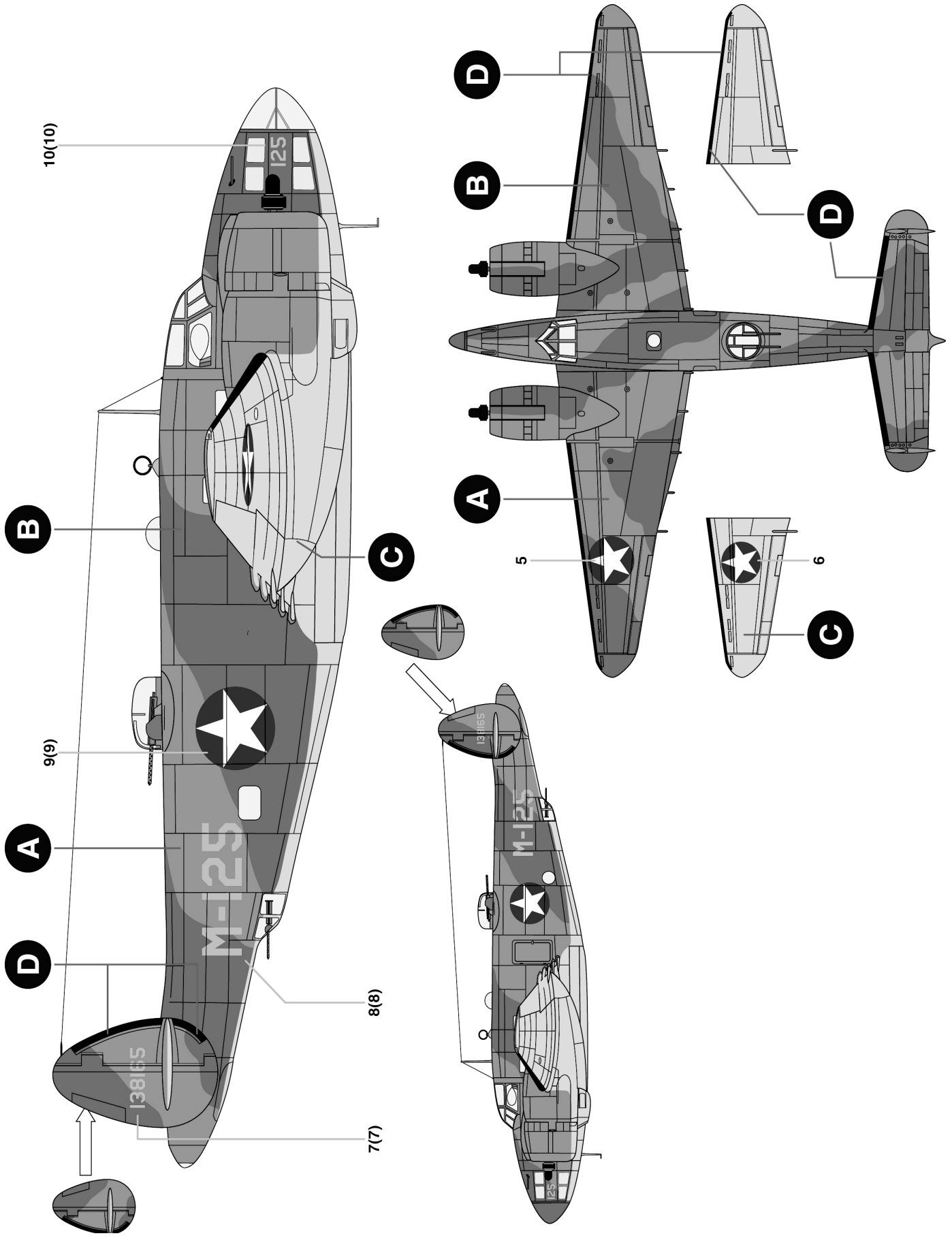



Your Minicraft model includes high-quality waterslide decals. These decals adhere best to a glossy surface; and it is recommended that you apply a clear gloss coat over your painted model.

Use a sharp scissors or knife to cut individual decals from the carrier sheet. Do not cut into the clear film surrounding the individual decals.

\* It is recommended that you apply one decal at a time.

\* Place the decal section in warm water, when first inserted in the water your decal will curl, after approximately ten seconds the decal will uncurl. Remove from water and lay on a paper towel. After approximately 10 - 20 seconds the decal will slide freely from the backing paper. Use a small brush to help slide the decal from the backing paper and into position on the model. Carefully blot excess water from the decal, using care not to move the decal or tear it.

\* If you choose to use a setting solution, apply a thin coat over the decal following the manufacturer's instruction.

\* Allow the decal to dry overnight. Wash any adhesive residue off the model with a small amount of clean water and dry thoroughly.

\* Apply clear gloss, matte or flat coat to seal decals following the instructions from the manufacturer.



*Legends in the making™*

Visit our Website-  
[www.minicraftmodels.com](http://www.minicraftmodels.com)

Minicraft Models (US) LLC  
1501 Commerce Drive  
Elgin, IL 60123

Phone: 847-429-9676