

FS35182 Australian Matilda Conversion (for Tamiya 35300 only)

1. Individual Track Links (32)
2. Upper Tracks(2)
3. Lower Tracks (2)
4. Oil Can Rack (2)
5. Muffler
6. Spare Tracks
7. Turret Ring (4)
8. Return Skid Mounts (12)
9. Rear Step (2)
10. Turret Stowage
13. Turret Stowage Boxes (3)
14. Front access Hatches (2)
15. Stowage Tube
16. Smoke Mount
17. Side Armor (2)
18. Track Guards(2)
19. Guard Mounts(4)
20. Guard Locks (2)
21. Return Skids (12)
22. Turret Box Mounts(6)

Track Assembly

The longer section runs across the top, shorter section along the bottom
7 individual links around front, 9 individual links around rear drive wheel

Oil Can Racks

Were originally mounted on the side armor at the rear, but driving through jungle soon made it obvious that they would be torn off, so they were mounted on top of the front fenders

Spare Tracks

These were welded on the upper side armour (A) 6 track lengths along side, 3 track lengths on front armour

Turret Stowage Boxes

Glue the mounts to the boxes then glue onto the hull

Track Return skids

Track return mounts should be positioned 2mm from top of inside armor plate. Use the mounting points on the reverse side as a guide to placement, then attach the return skids

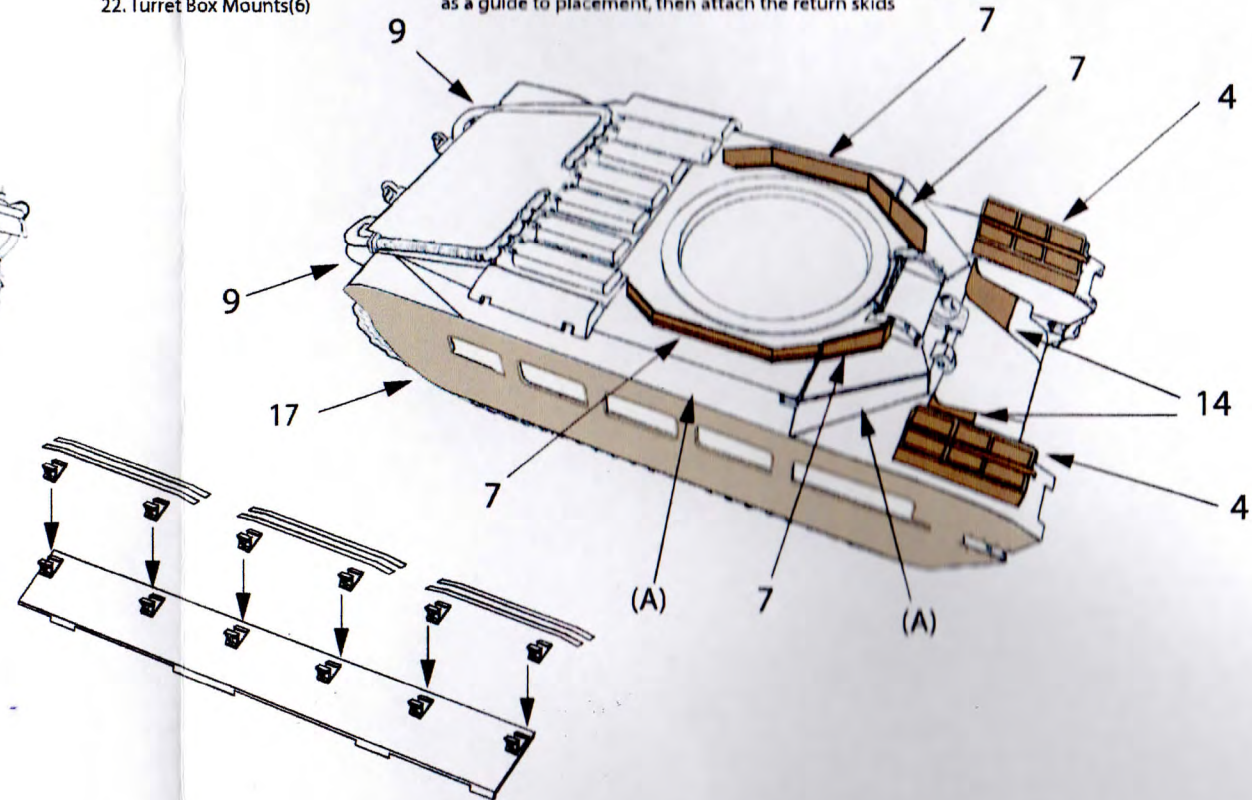
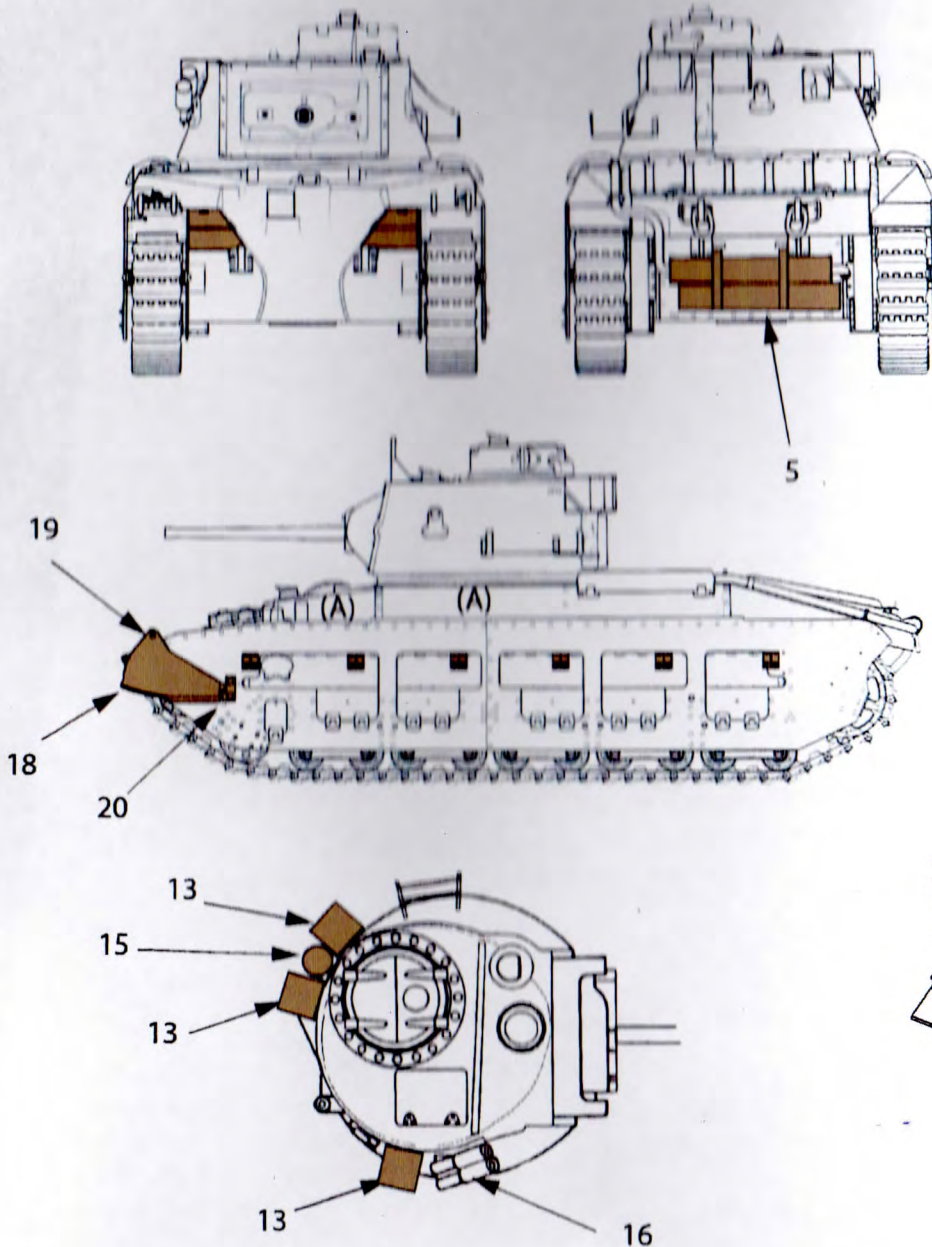

FS35182 Australian Matilda Conversion (for Tamiya 35300 only)

1. Individual Track Links (32)
2. Upper Tracks(2)
3. Lower Tracks (2)
4. Oil Can Rack (2)
5. Muffler
6. Spare Tracks
7. Turret Ring (4)
8. Return Skid Mounts (12)
9. Rear Step (2)
10. Turret Stowage
13. Turret Stowage Boxes (3)
14. Front access Hatches (2)
15. Stowage Tube
16. Smoke Mount
17. Side Armor (2)
18. Track Guards(2)
19. Guard Mounts(4)
20. Guard Locks (2)
21. Return Skids (12)
22. Turret Box Mounts(6)

Track Assembly

The longer section runs across the top, shorter section along the bottom
7 individual links around front, 9 individual links around rear drive wheel

Oil Can Racks

Were originally mounted on the side armor at the rear, but driving through jungle soon made it obvious that they would be torn off, so they were mounted on top of the front fenders

Spare Tracks

These were welded on the upper side armour (A) 6 track lengths along side, 3 track lengths on front armour

Turret Stowage Boxes

Glue the mounts to the boxes then glue onto the hull

Track Return skids

Track return mounts should be positioned 2mm from top of inside armor plate. Use the mounting points on the reverse side as a guide to placement, then attach the return skids

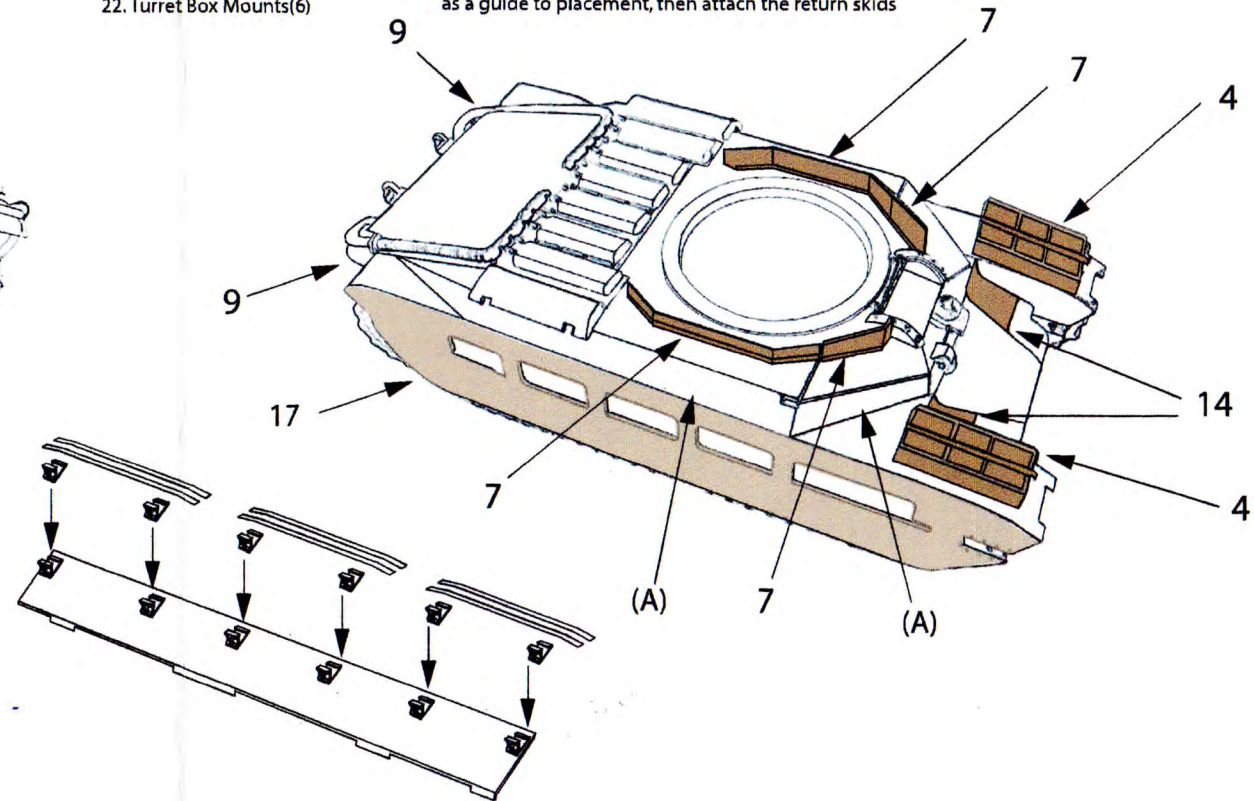
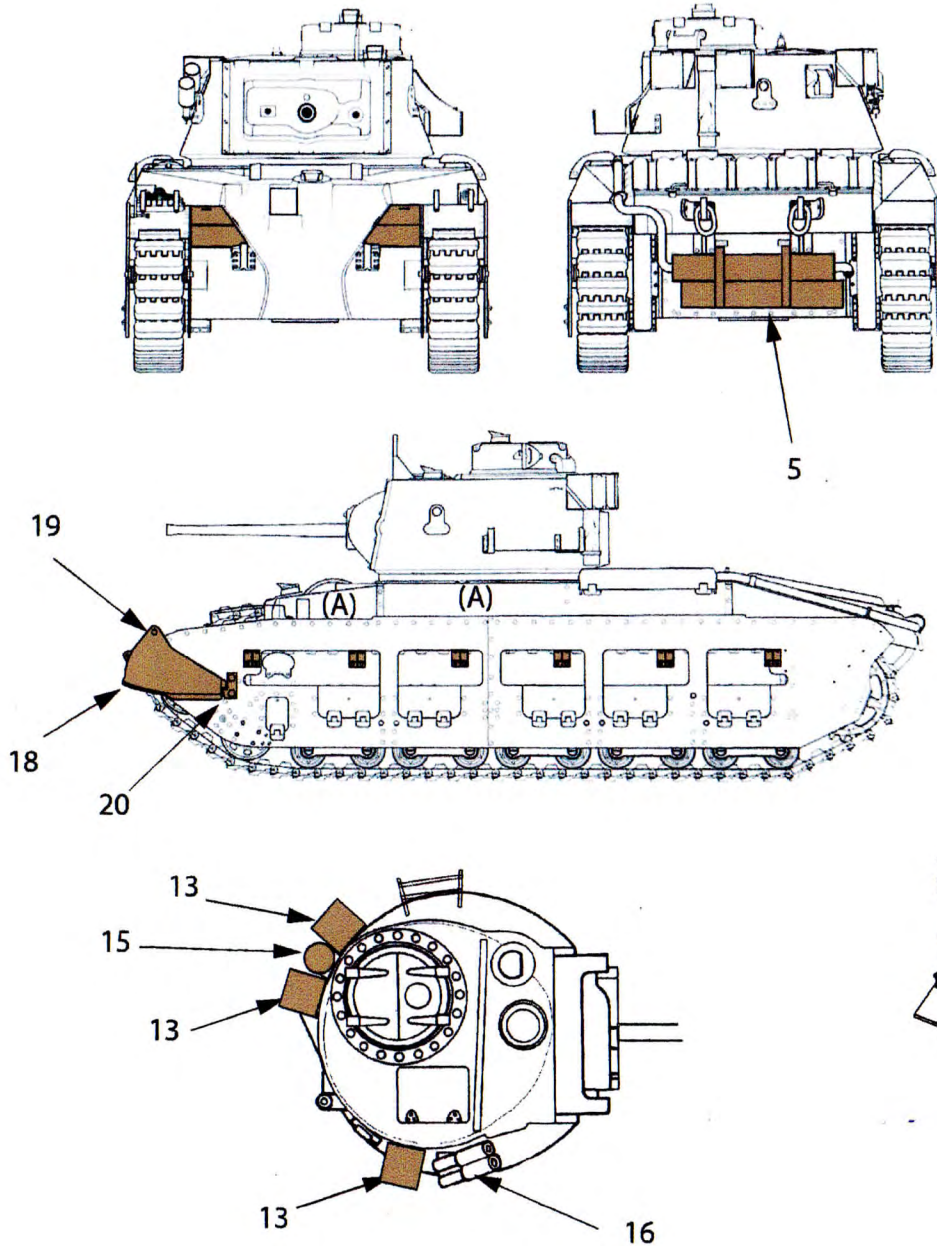

ASSEMBLY GUIDE 组装说明:

x2 2 sets needed
同样的制作两组

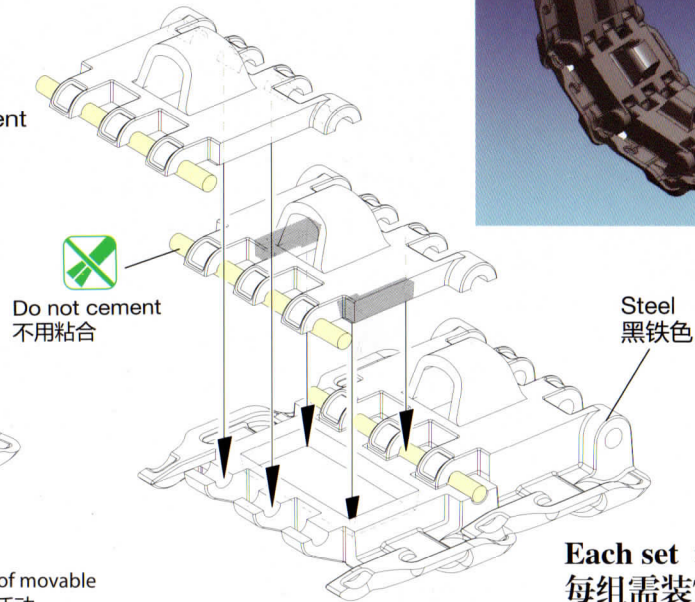
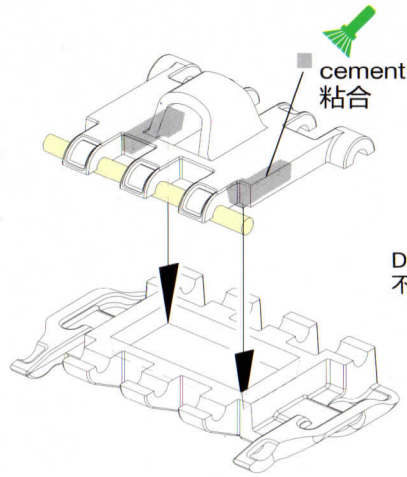

* please careful to glue the parts,
too much glue will influence the action of movable
请小心使用胶水,过多胶水会影响履带活动

Each set × 71 pc
每组需装71枚

