

35 K12

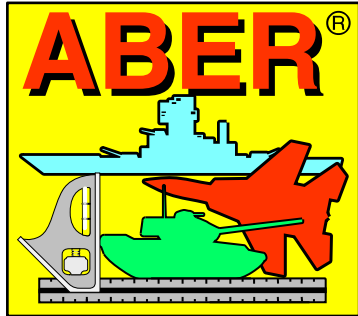

EXCLUSIVE EDITION

**UPGRADE SET
FOR DRAGON
1/35 MODELS**

Can be used to models of Kingtiger another producers

GERMAN HEAVY TANK
Pz.Kpfw. VI, Ausf.B "KINGTIGER"
(Sd.Kfz. 182) Henschel Turret

Niemiecki czołg Pz.Kpfw. VI, Tiger Ausf.B (Sd.Kfz. 182) z wieżą typu Henschel

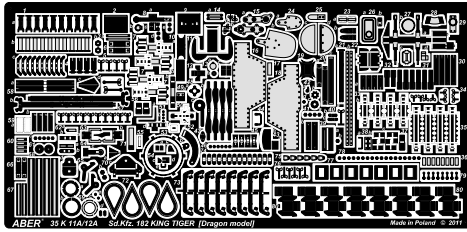
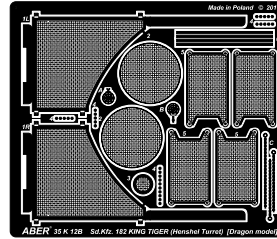
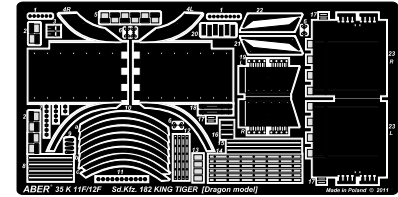
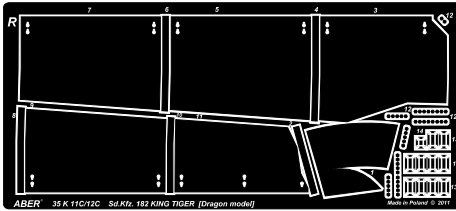
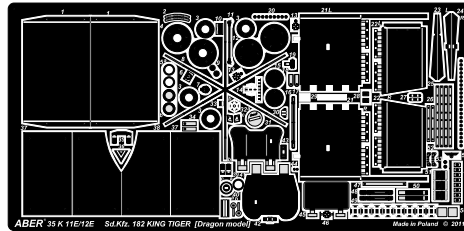
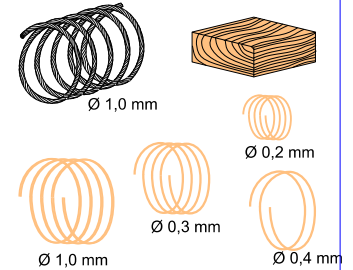
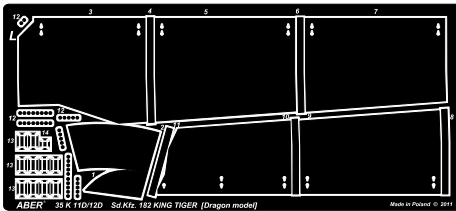
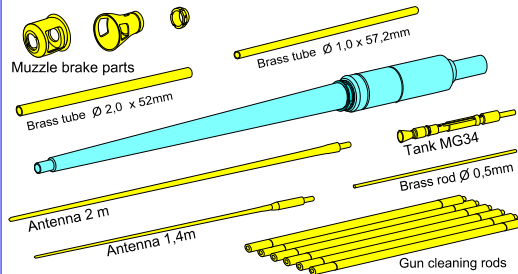
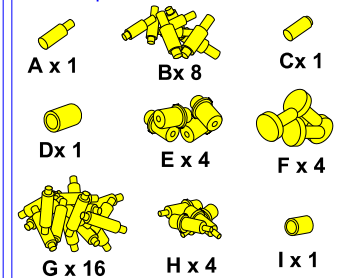
A**B****F****C****E****Bag with cable, wires & wood chock****D****Bag with ABER barrels, antennas, tubes and rods****Turned parts**

MOST IMPORTANT BIBLIGRAPHY:

- 1) Achtung Panzer No.6 - Panzerkampfwagen Tiger by Mitsuru Bitoh
- Dai Nippon Kaiga Co.,Ltd. ©1999
- 2) GROUND POWER No. 043, 053, 094, 095 - Delta Publishing Co.,Ltd. ©1997
- 3) Militärfahrzeuge Band 7; Der Panzer-Kampfwagen Tiger und Seine Abarten -
Walter J. Spielberger - Motorbuch ©1994
- 4) Schwere Panzer in Detail - B. Culver & U. Feist - Ryton Publications ©1998
- 5) AFV Modeling Guide Vol.2 - TIGER II - Geibun Mooks No.641
- 6) New Vanguard 1: KINGTIGER Heavy Tank 1942-1945 - Osprey Military ©1993
- 7) Sd.Kfz.182 Pz.Kpfw. VI Tiger Ausf.B "Königstiger - Waldemar Trojca vol.1 & 2 ©2003
- 8) AFV Super Detail Photo Book Vol.8 Sd.Kfz 182 VI Tiger Ausf.B KINGTIGER - ModelArt ©2008
- 9) Tiger Tank - A complete and comprehensive guide to modeling the Tiger I and
Tiger II in 1/35th scale - Military Miniatures in Review ©2002
- 9) German`s TIGER TANKS VK45.02 to Tiger II - Thomas L.Jentz & Hilary L. Doyle

Thank you for purchase our set **35 K12**.

Read carefully this instruction.

We advise that better method to join metal to metal parts is soldering.
Cement metal parts to plastic with good cyanoacryl or epoxy glue.

WARNING

Any unauthorized copying, producing and reproducing of ABER company products, or any part thereof, is strictly prohibited and any such action establishes liability for a civil action and may give rise to criminal prosecution.

OSTRZEŻENIE

Jakiegokolwiek kopiowanie, produkowanie i reprodukcja wyrobów firmy ABER bez zezwolenia, w całości lub części jest surowo zabronione. Powyższe działania powodują powstanie odpowiedzialności cywilnej oraz mogą spowodować wszczęcie postępowania karnego.

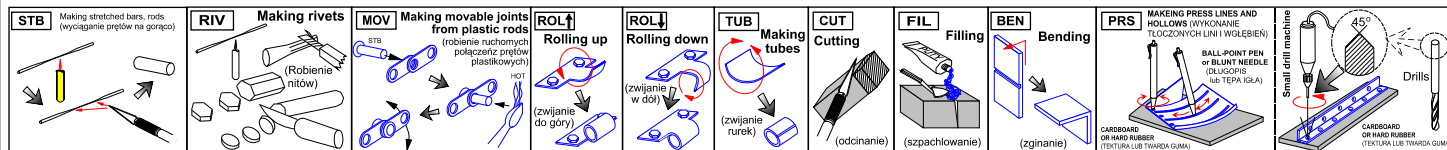

TOOLS RECOMMENDED

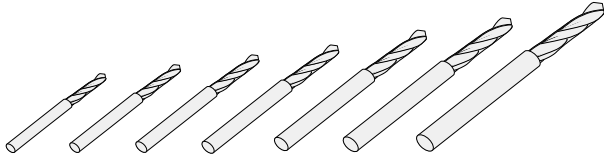

Drills from \varnothing 0,4 to 1,5 mm

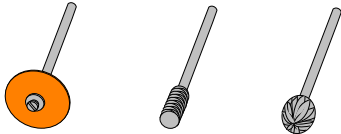

Assortment of cutting wheels and mills

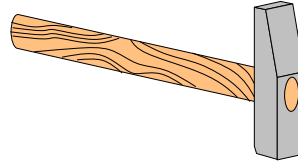

Light weight hammer

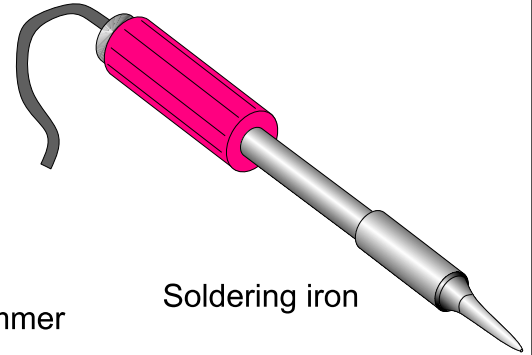

Soldering iron

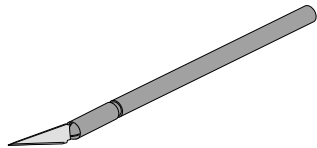

Sharp knife

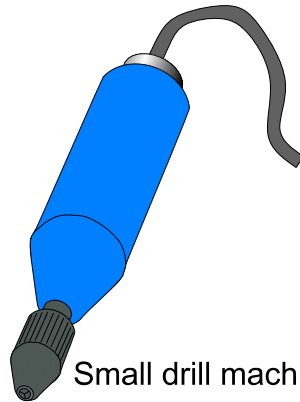

Small drill machine

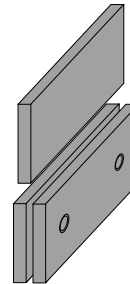

Bending tool
PG01 or PG02



Soldering flux

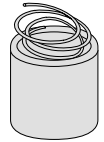

Solder

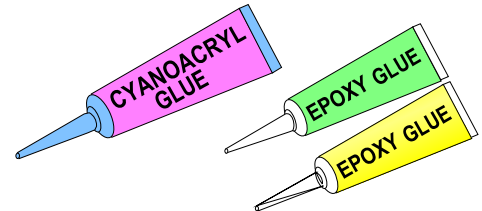

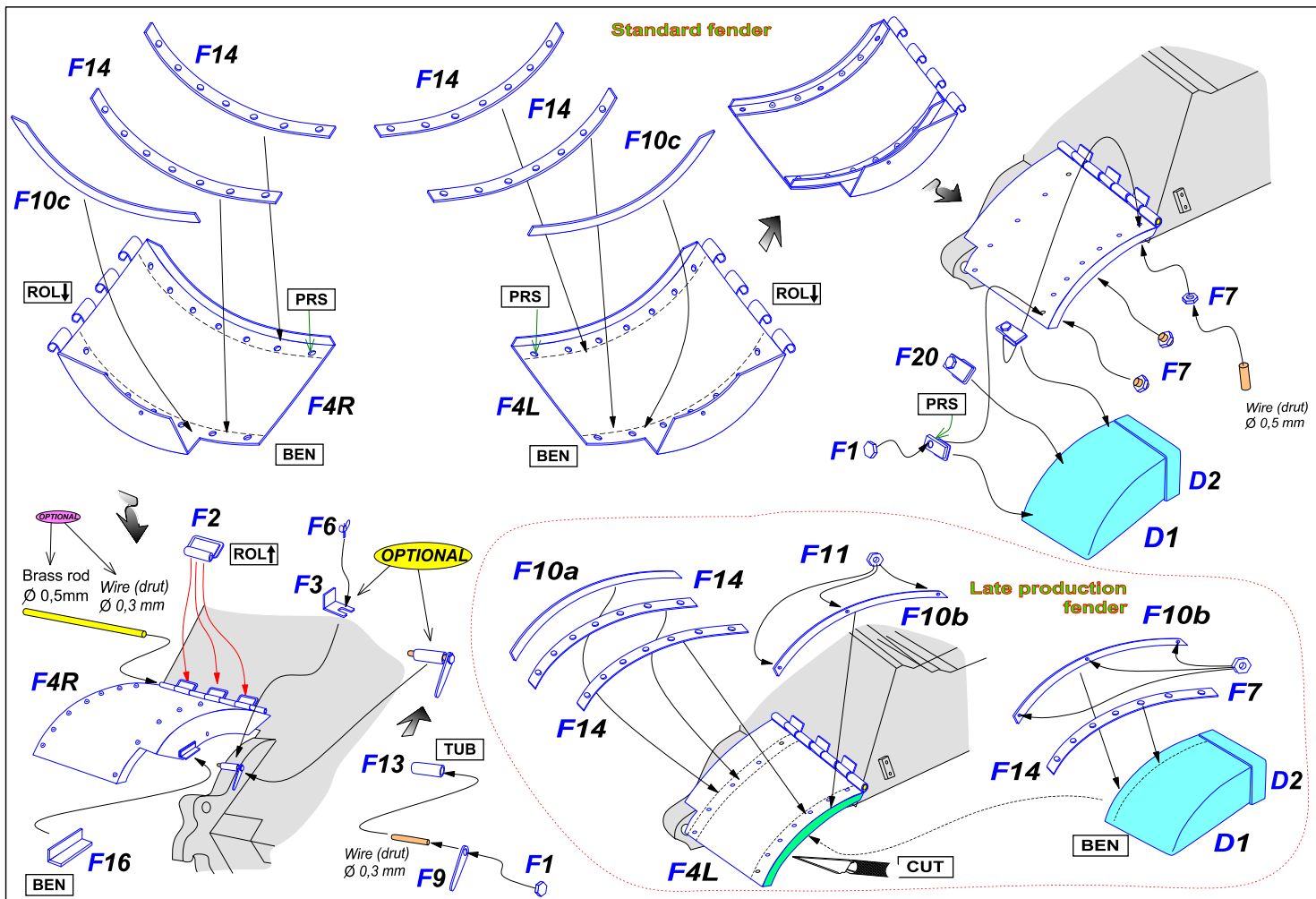

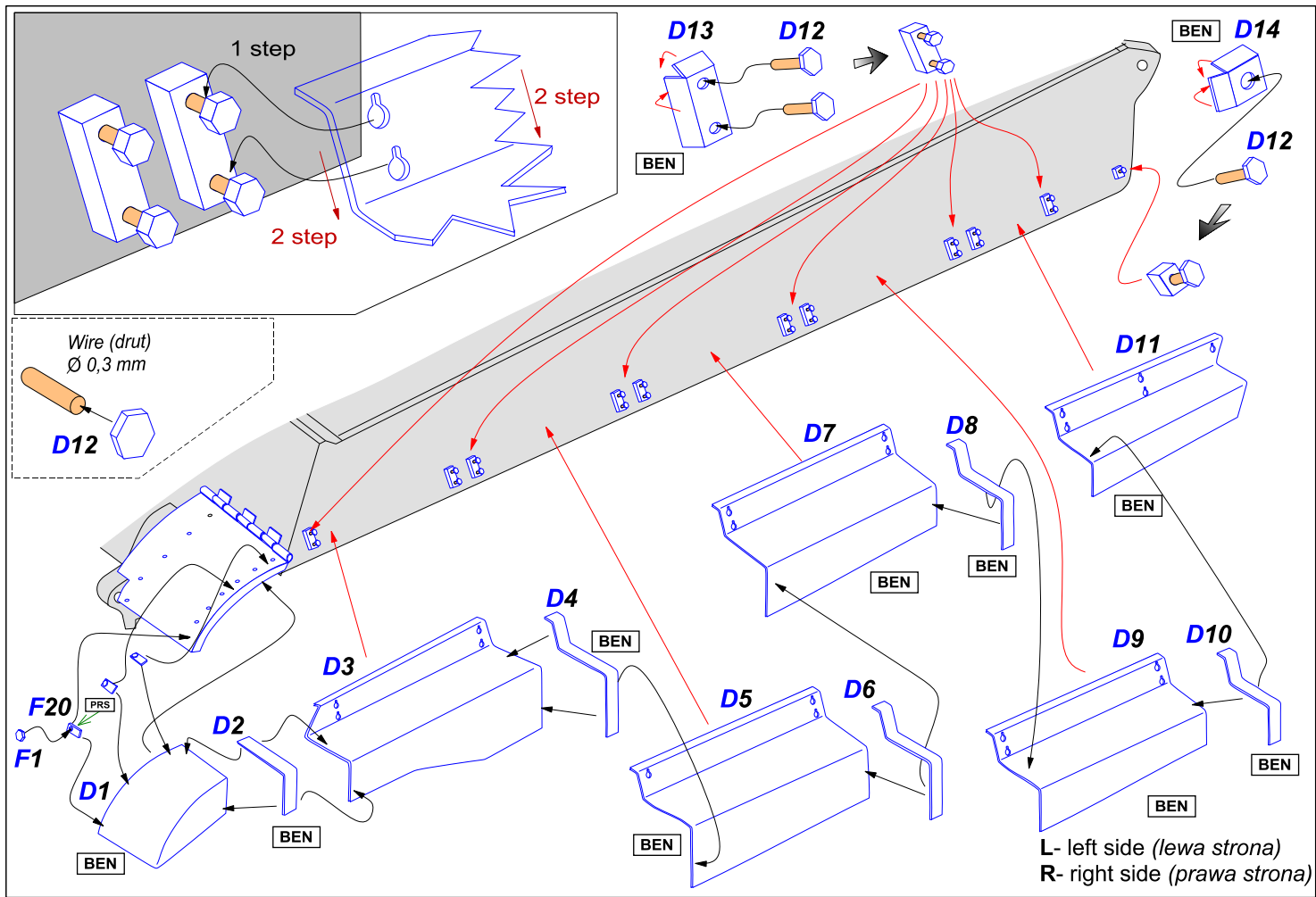

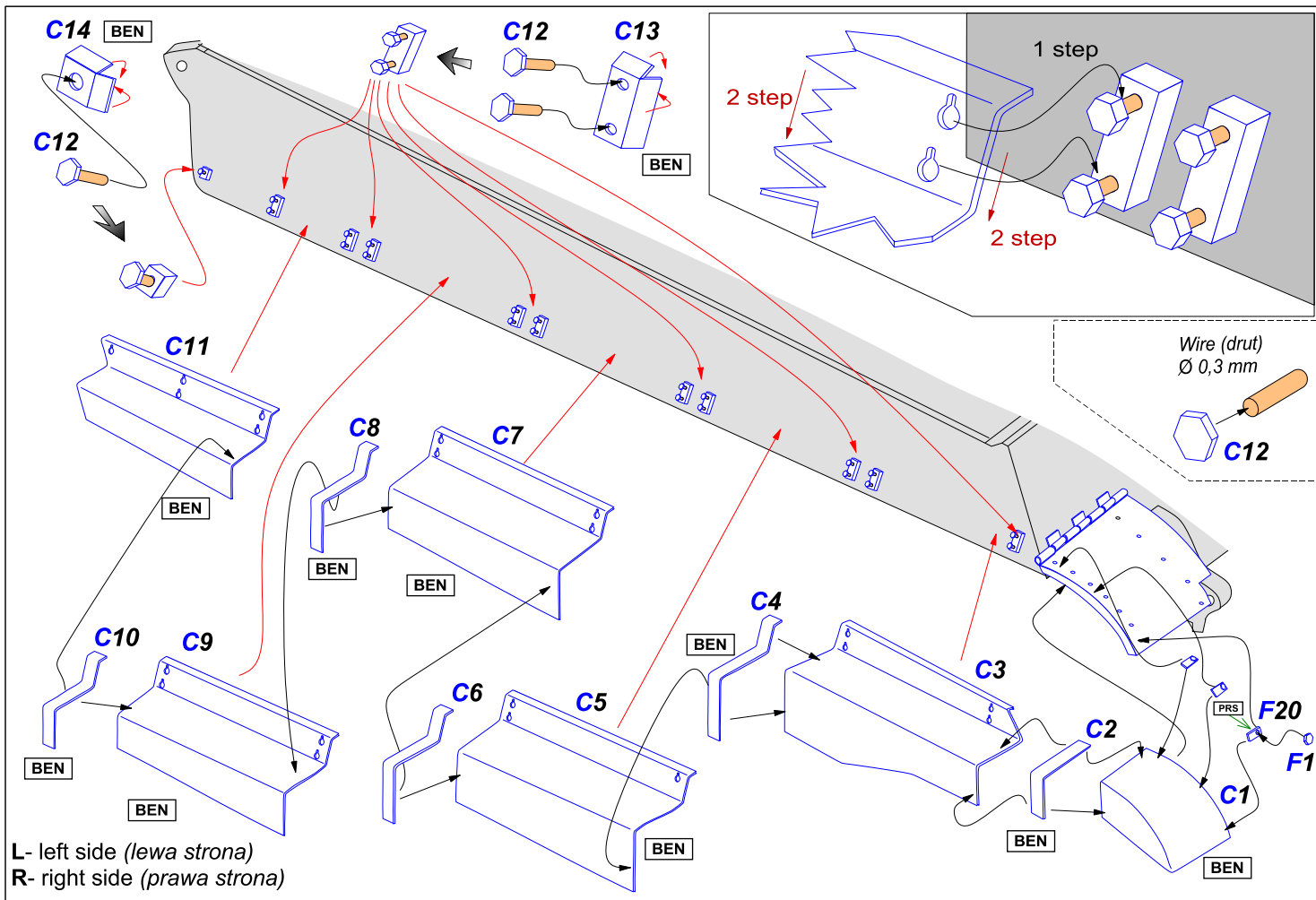

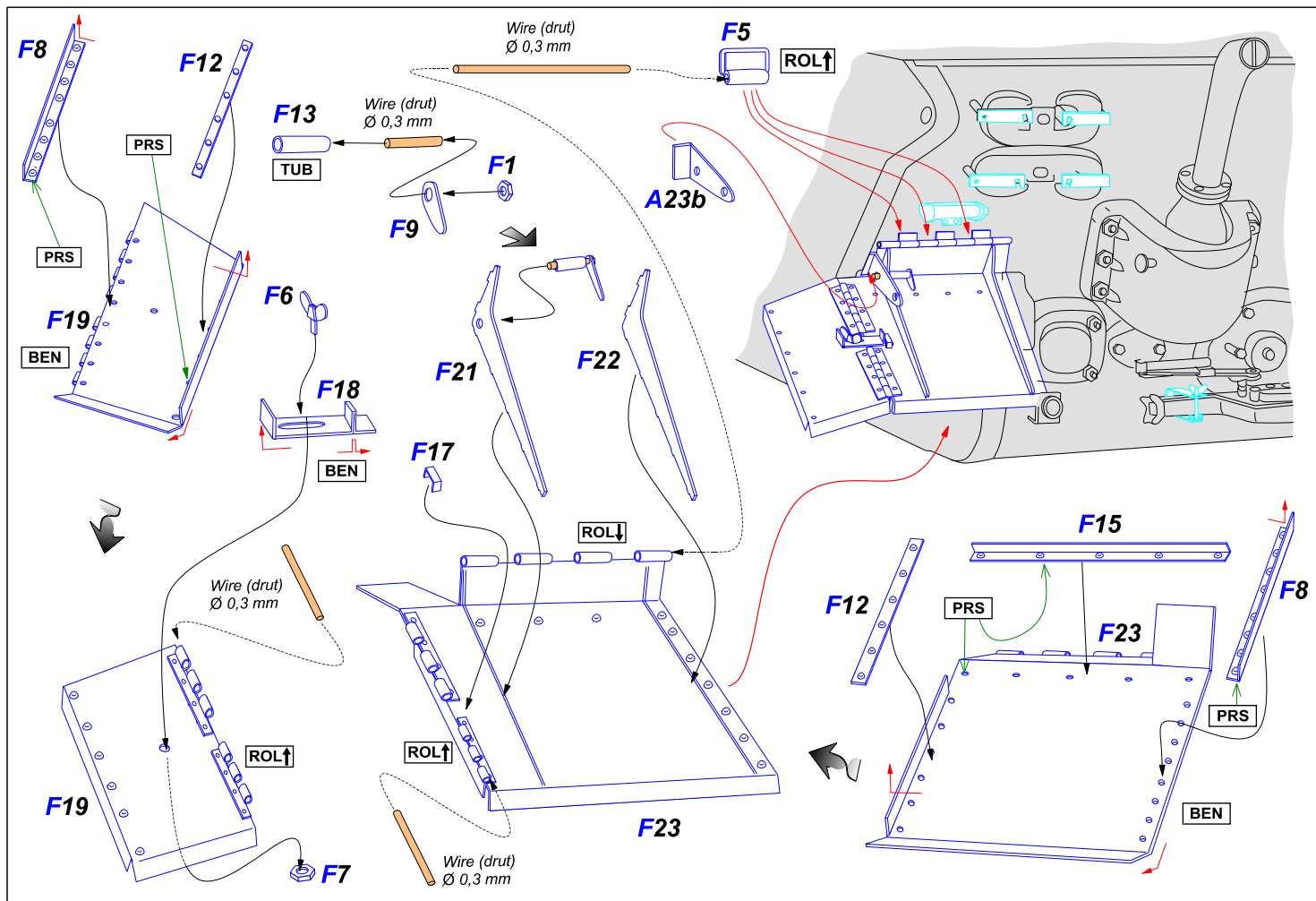

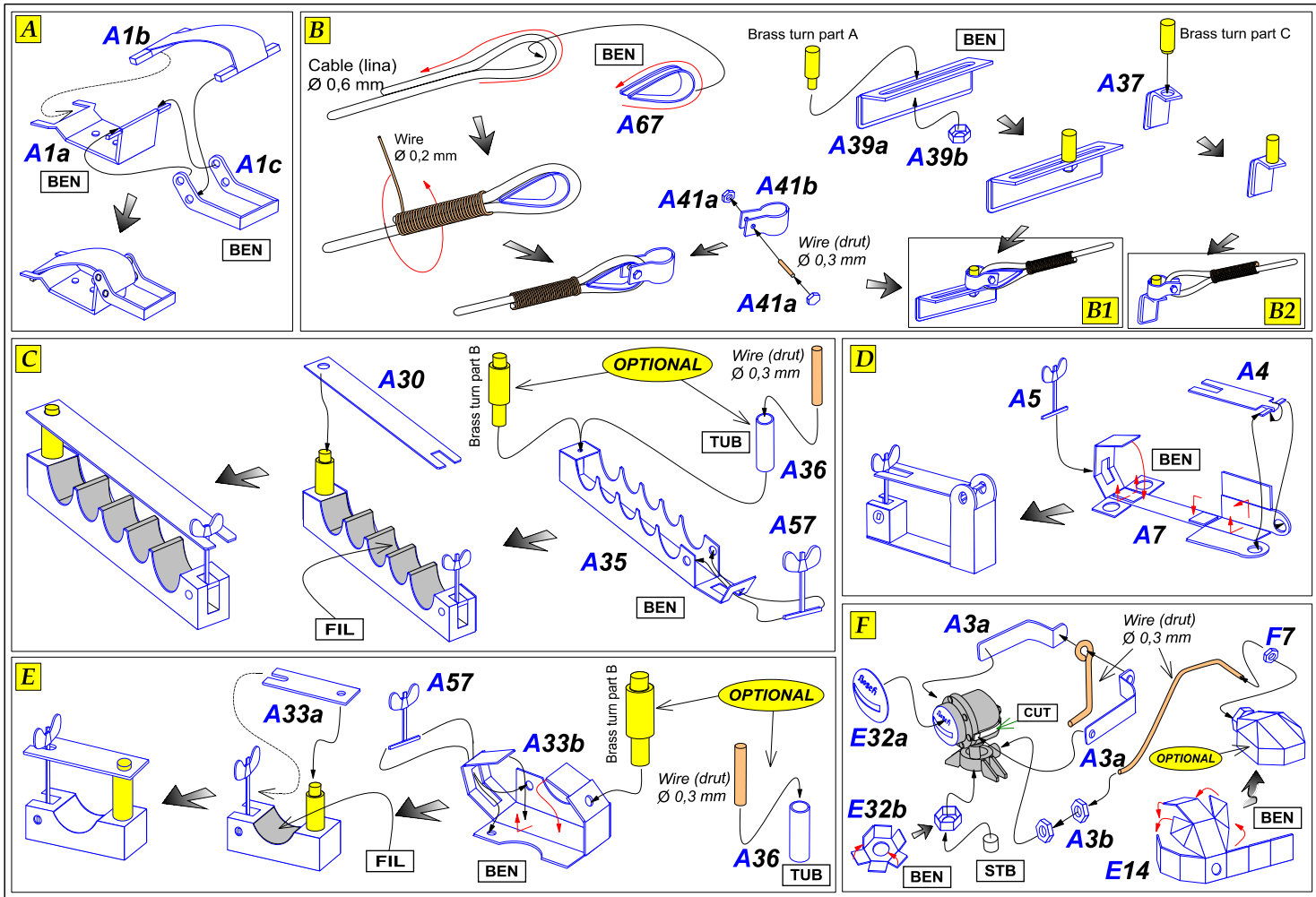

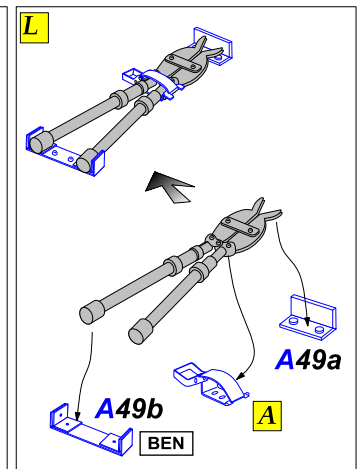
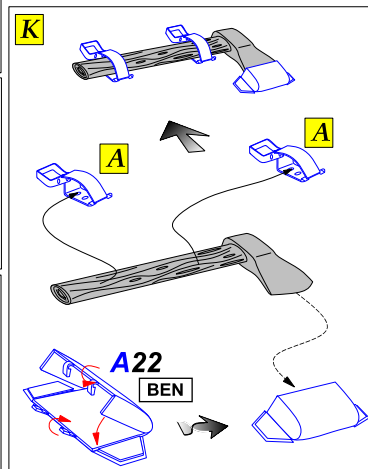
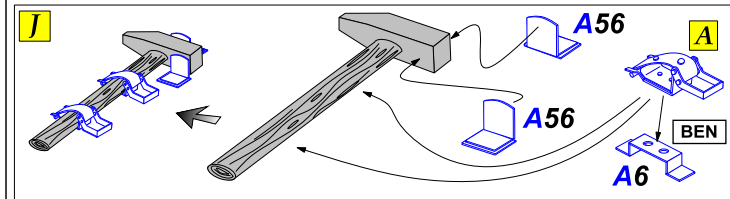
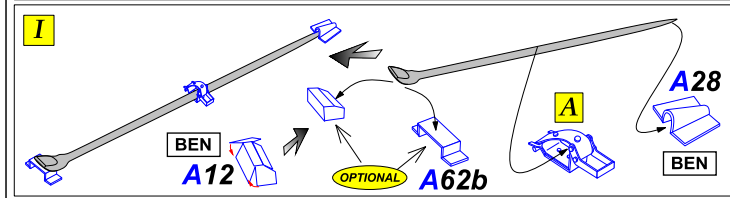
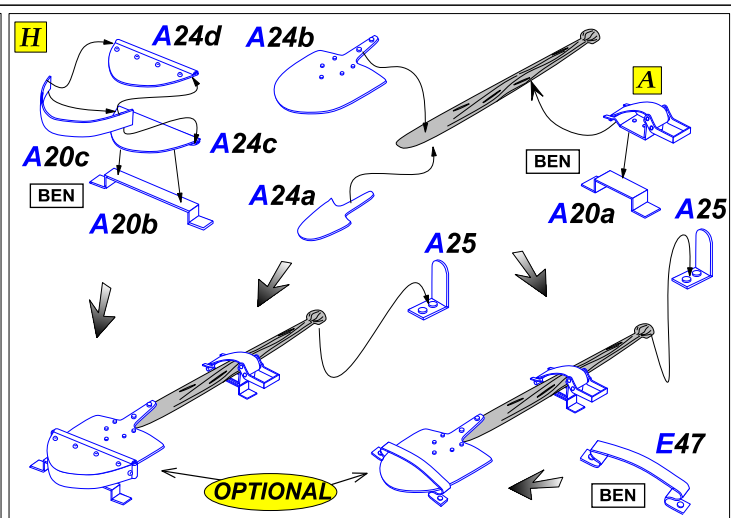
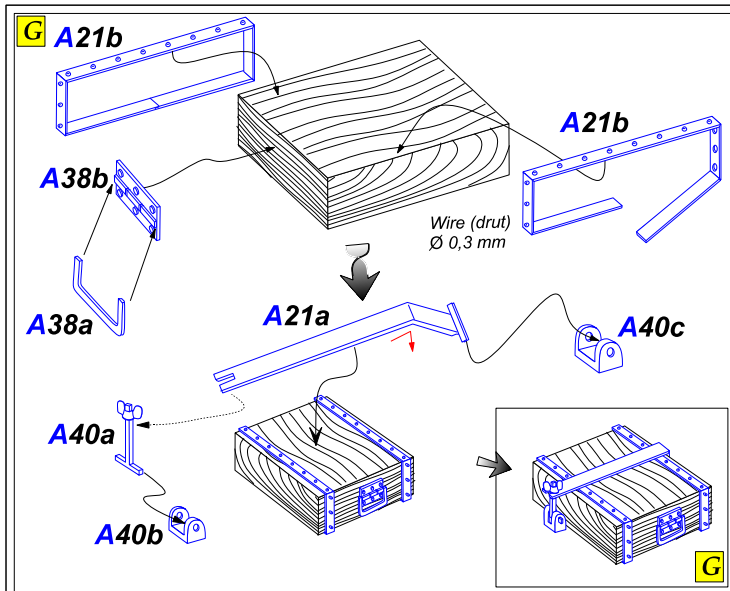

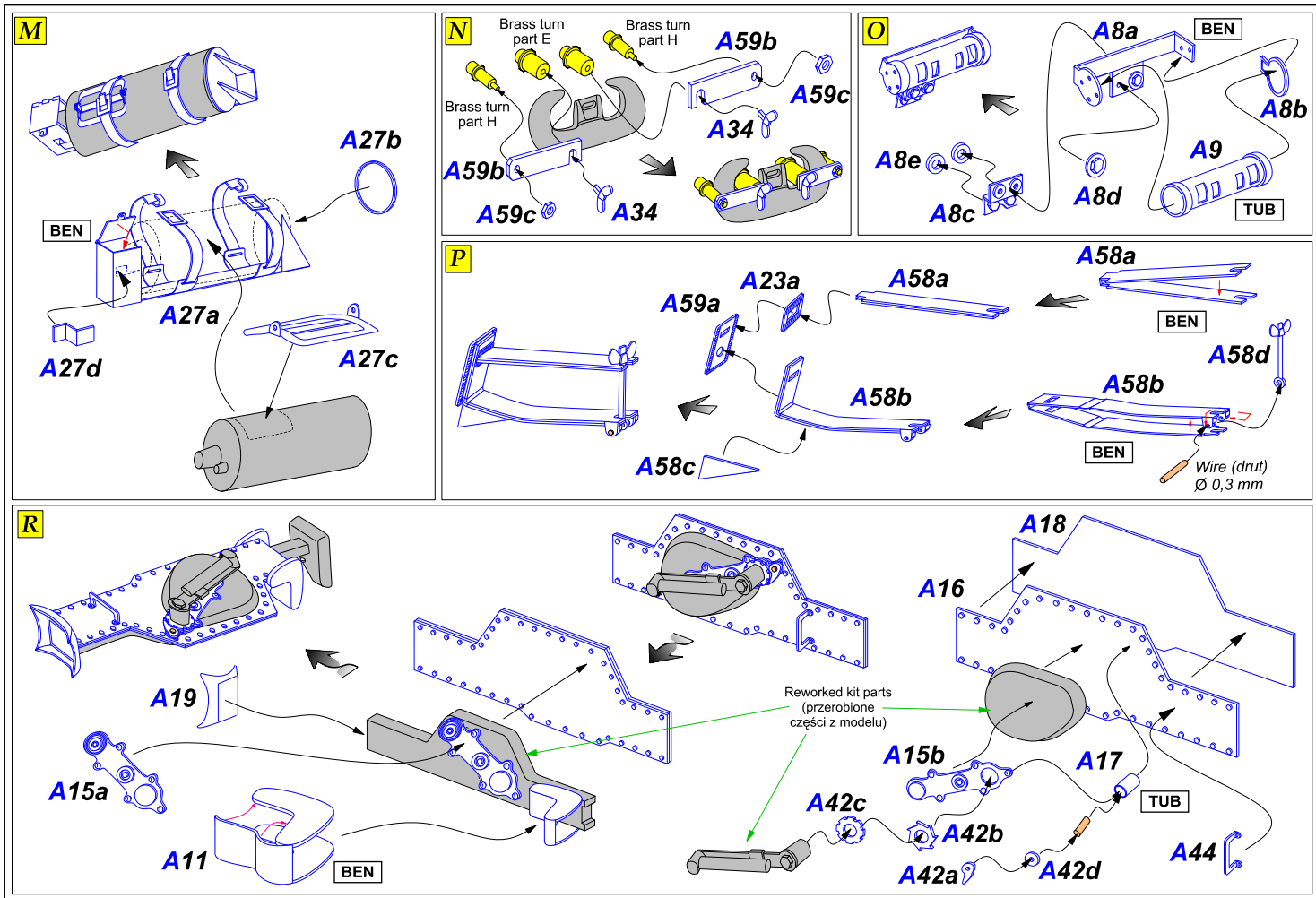

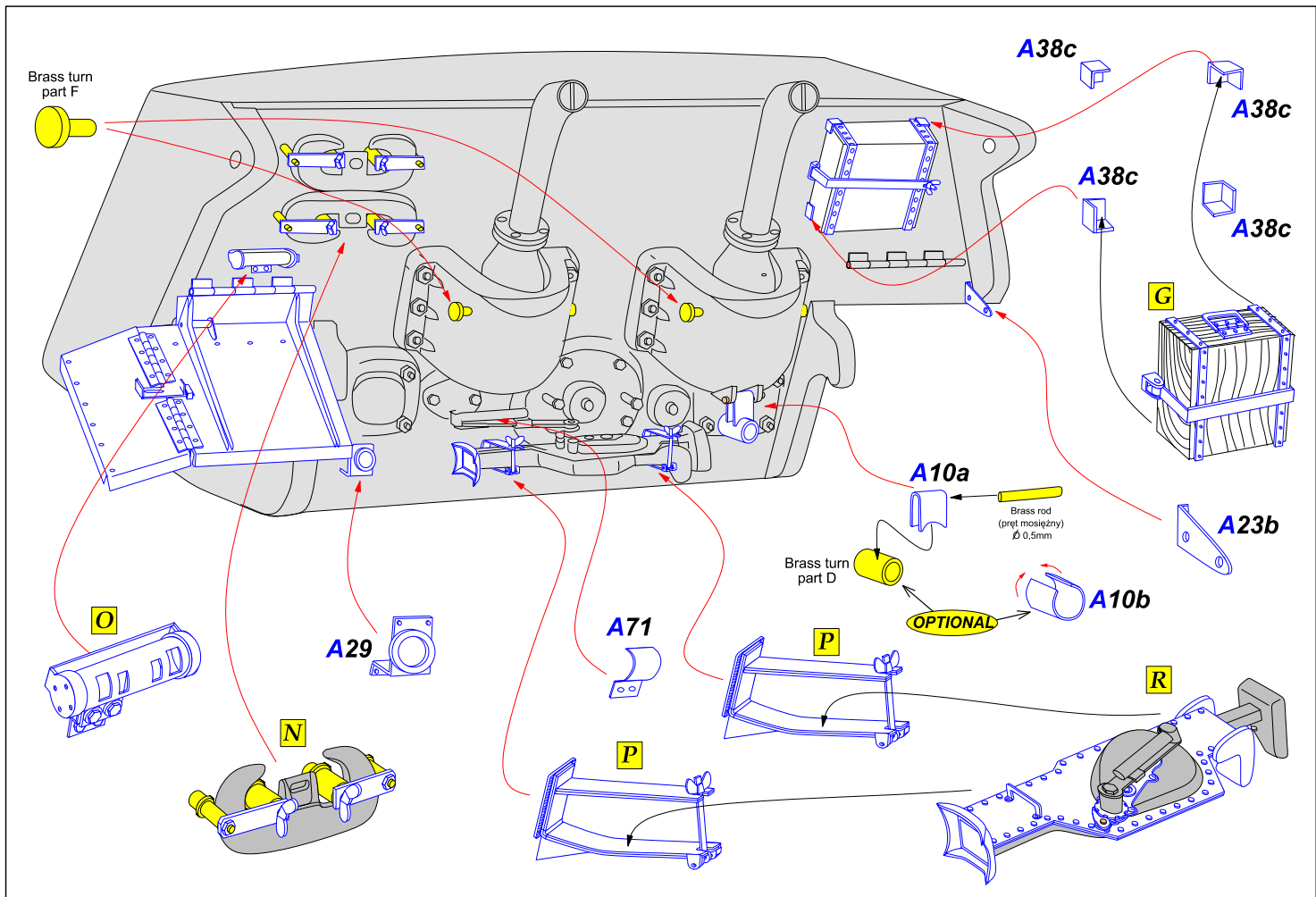

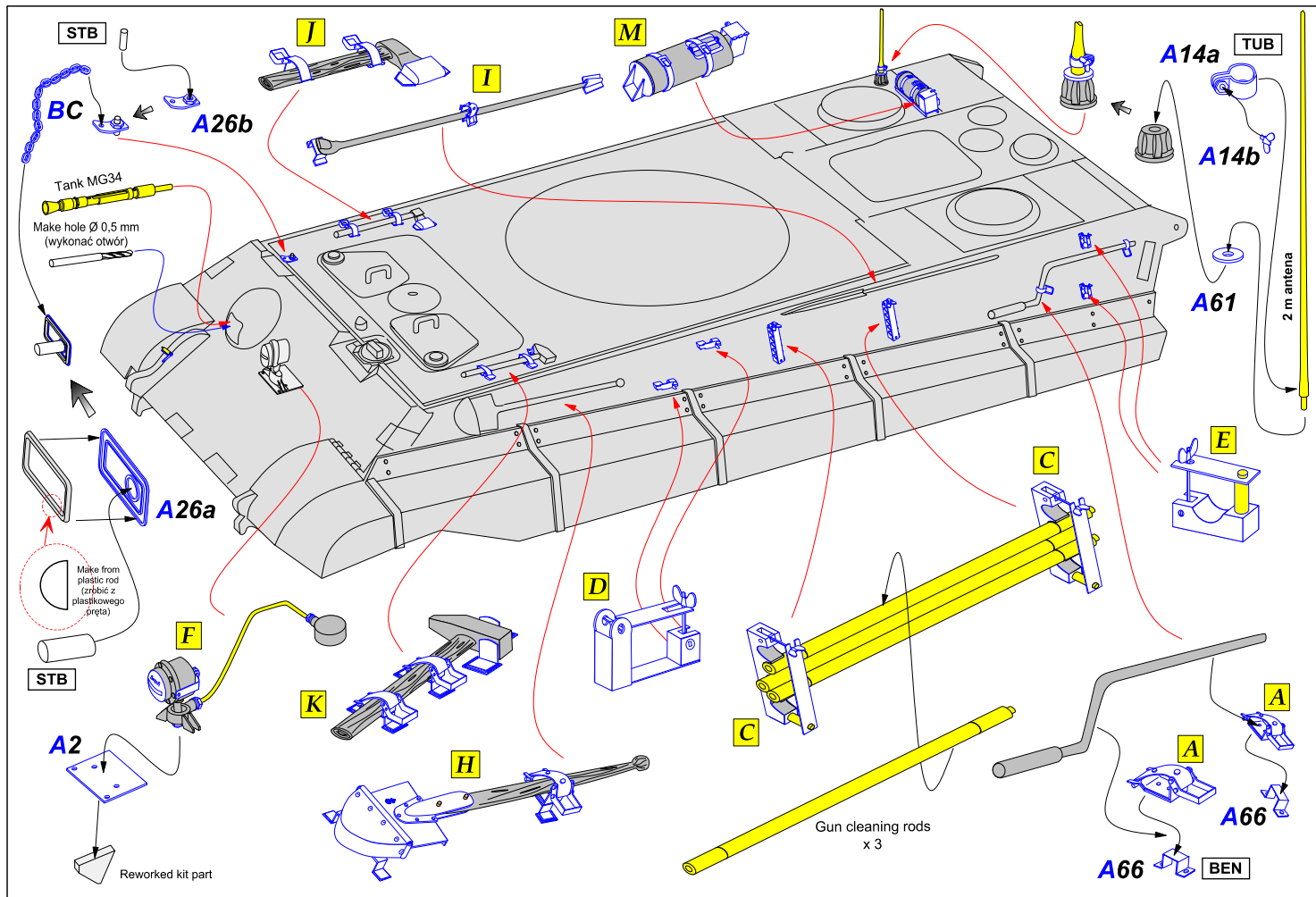

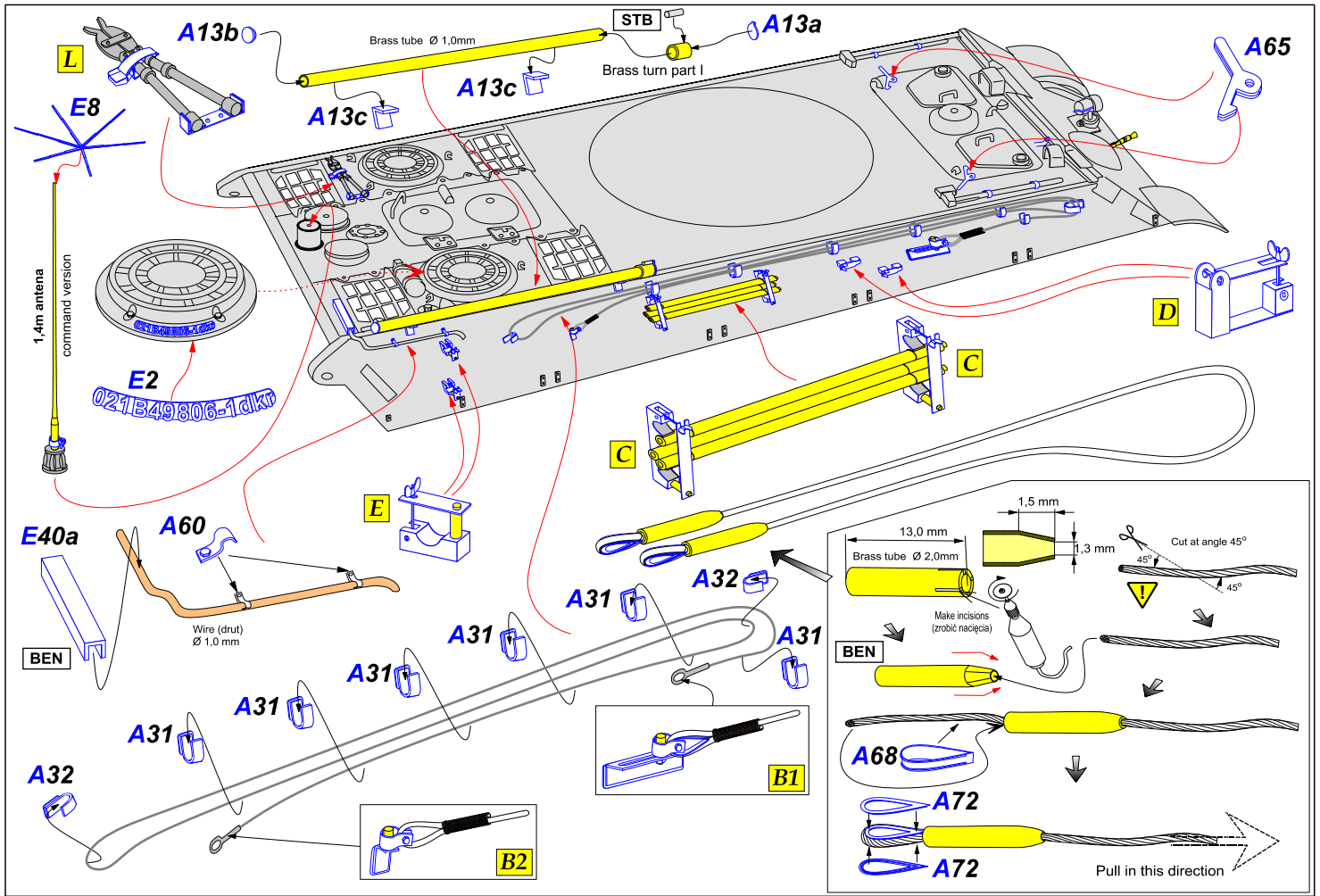

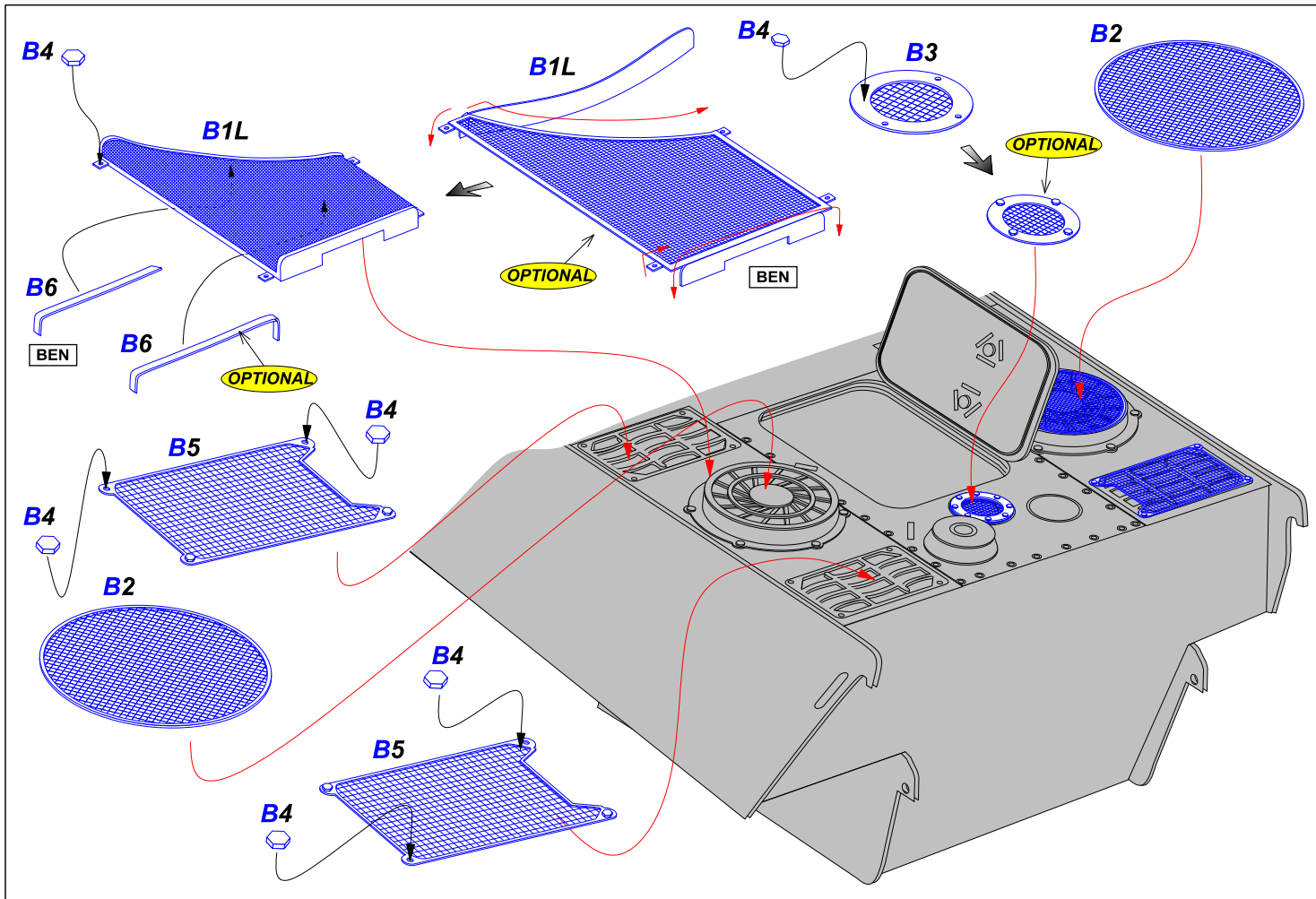

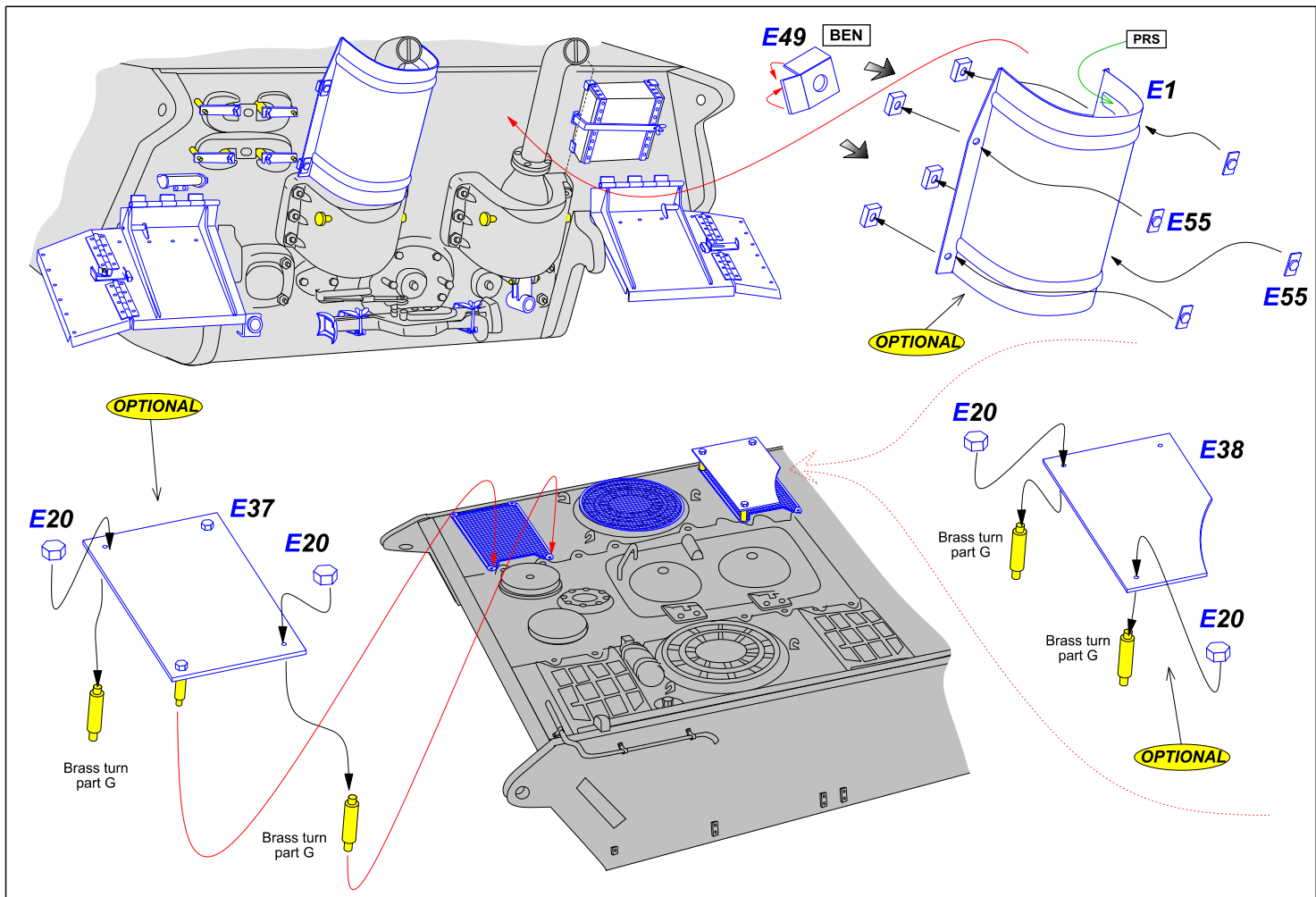

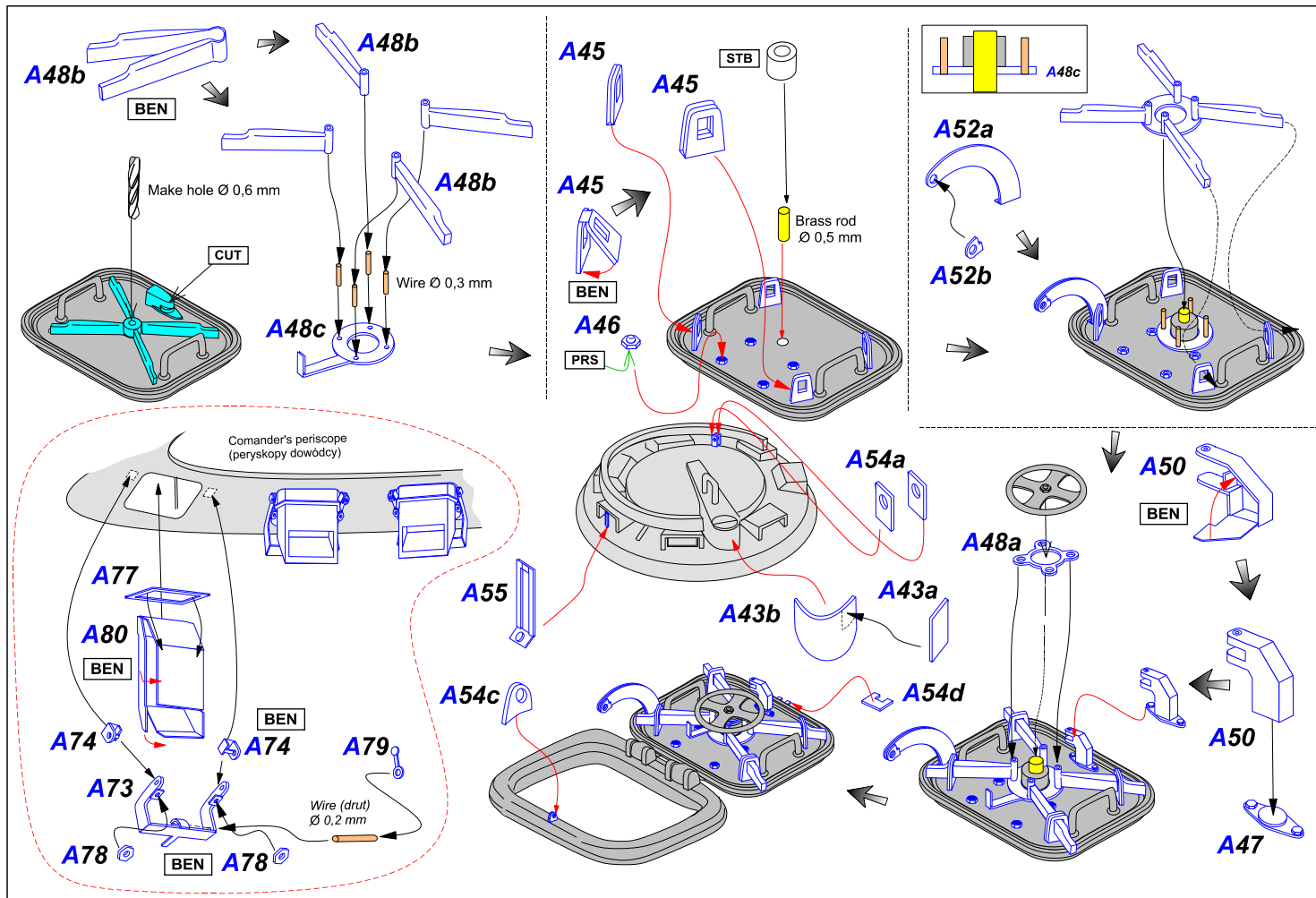

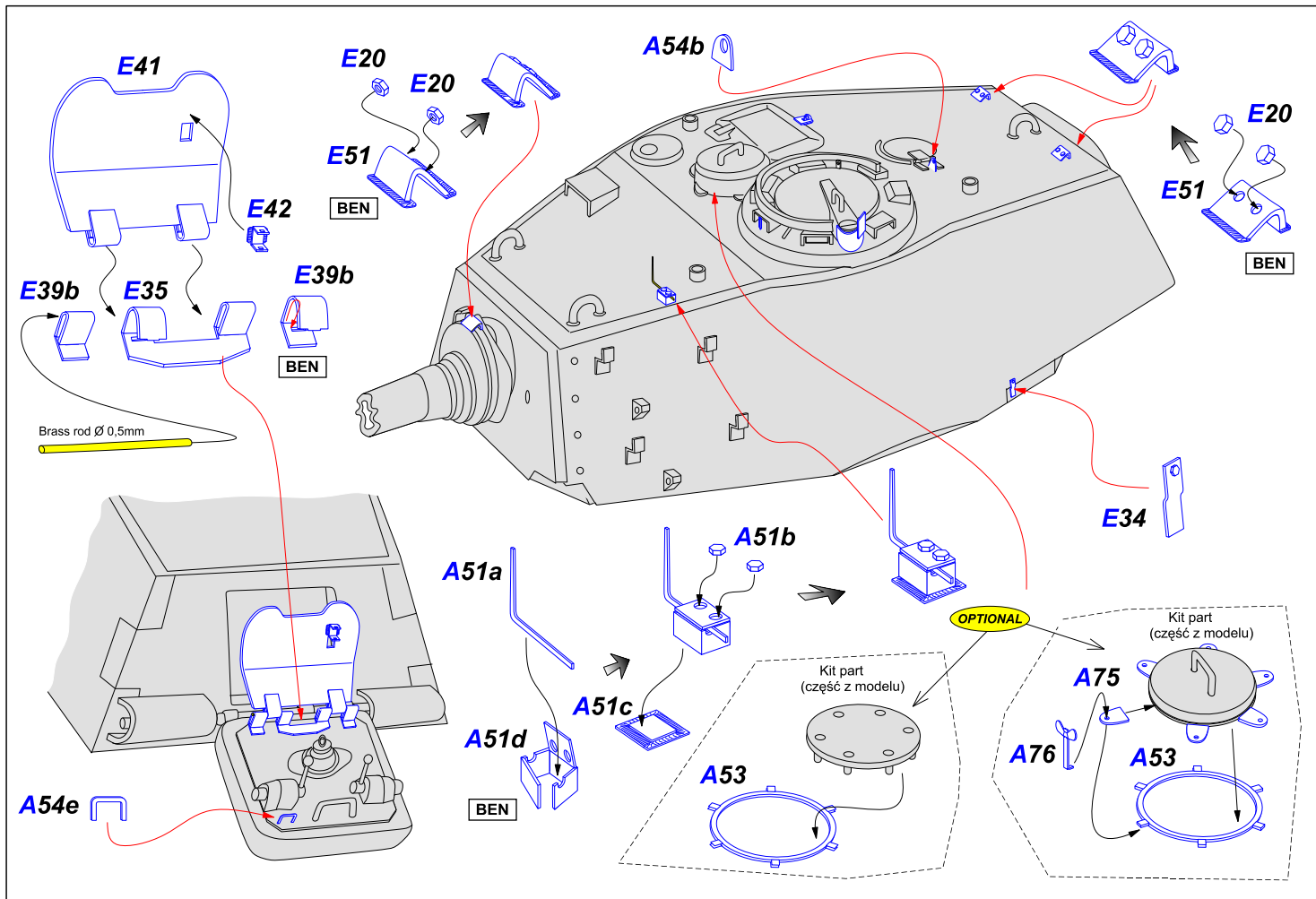

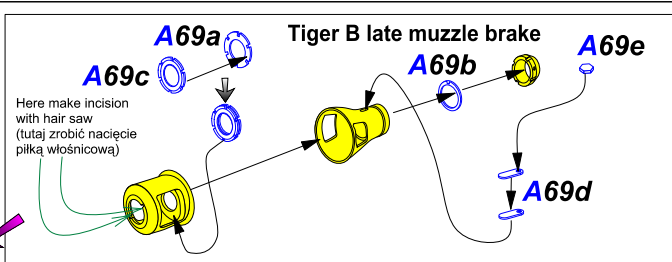

Tiger B Serien-Turm early

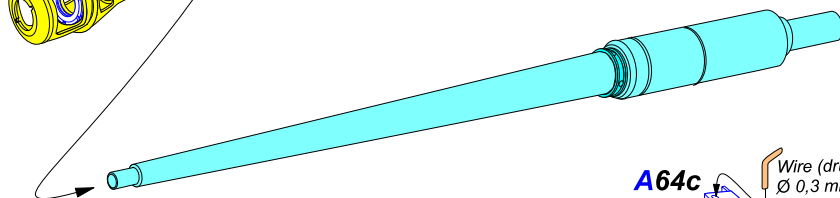
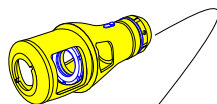
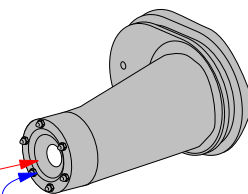

Make hole \varnothing 3,8 mm
(wykonać otwór)

