



**48001**  
**RESIN KIT**

# AVIATIK

## 30.40

**AUSTRO-HUNGARIAN WWI FIGHTER**



Prototyp Aviatik 30.40 poháněný rotačním motorem Le Rhone (St) o výkonu 150hp byl nejnáročnějším pokusem o splnění požadavků na projekt záhybného stíhače. Vážíci s maximální zátěží pouze 586 kg to byl nejlehčí stíhací letoun postavený v Rakousko-Uhersku. Drak letounu byl odvozen z dvojplošniku typu 30.27 a křídlo typu parasol zavěšené na vzpěrách bylo dokonale vyzkoušeno na letounu Aviatik D.II. Na základě velmi slibných výsledcích zaznamenaných během testů prováděných v červenci a srpnu 1918, byl typ 30.40 navržen pro sériovou výrobu v továrně Thöne&Fiala.

#### UPOZORNĚNÍ:

Použitý materiál je křehký a citlivý na teplo. Možné deformace lze odstranit vložením do horké vody. Po upravení do požadovaného tvaru ochlaďte ve studené vodě. K lepení používejte kyanoakrylátové lepidlo.



The Aviatik 30.40 prototype powered by 150 h.p. Le Rhone (St) rotary engine was Aviatik's most ambitious effort to meet the interceptor requirements. Weighing only 586 kg fully loaded it was the lightest fighter built in Austria-Hungary. The airframe was derived from 30.27 bi-plane and the strut-braced parasol wing had been thoroughly tested on the Aviatik D.II. Based on promising performance recorded during trials in July and August 1918, the 30.40 was proposed for production by Thöne&Fiala company.

#### NOTICE:

Used material is brittle and sensitive to heat. Incidental deformations can be removed by putting the part to hot water, after arrangement cool it down in cold water. Use cyanoacrylat adhesive.

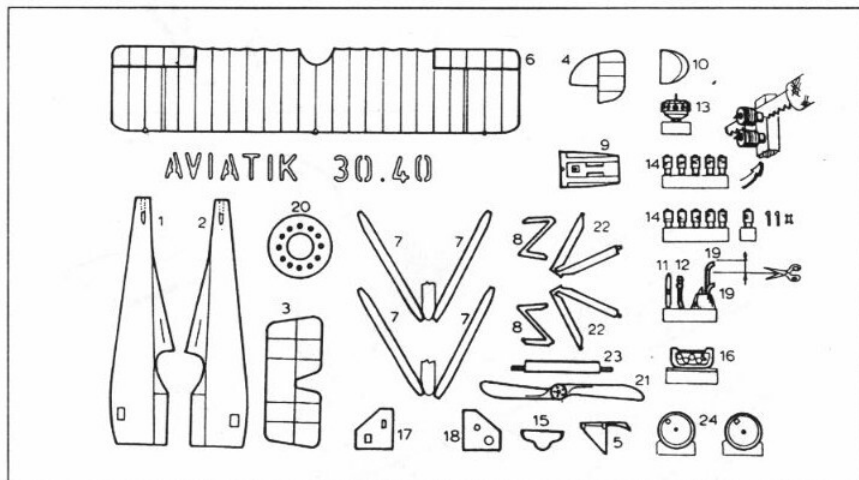

**MODELIMEX, Slovenská 2648, 415 01 TEPLICE, CZECH REPUBLIC**  
**tel/fax: +420 417 381 980**





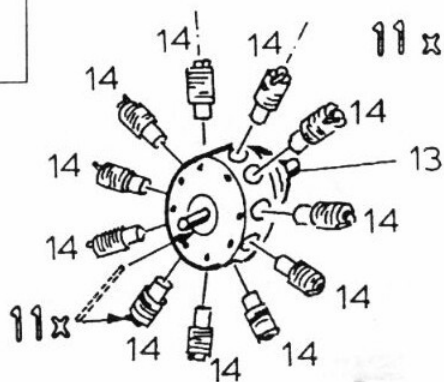
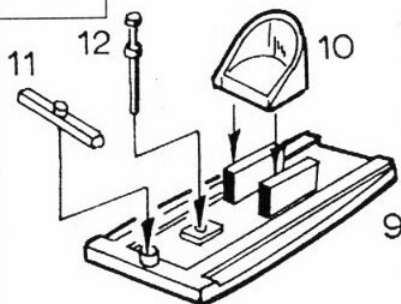
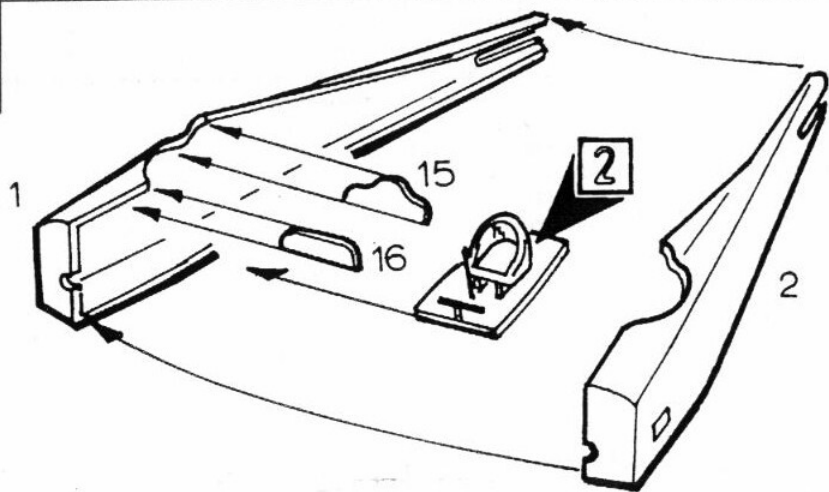
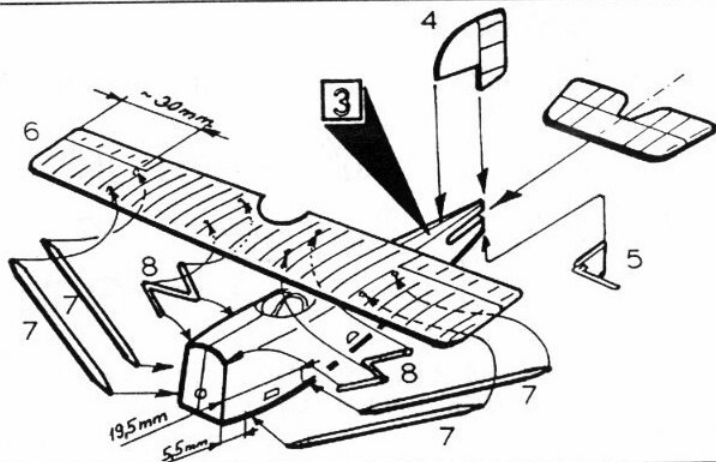

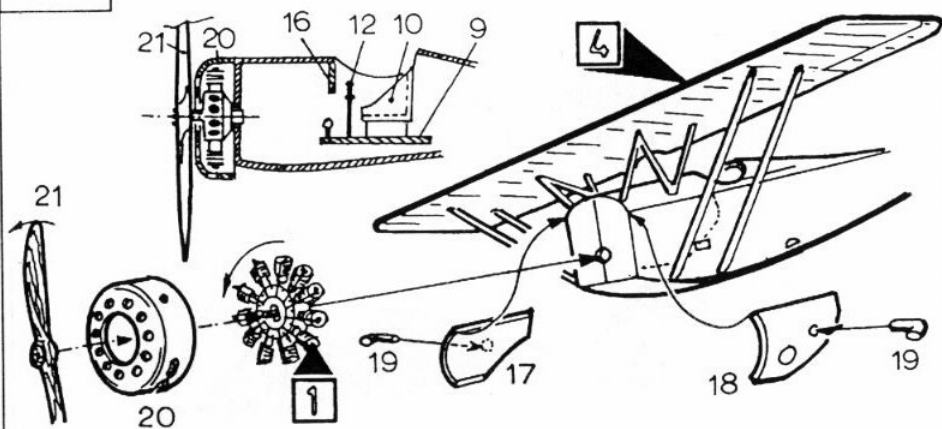
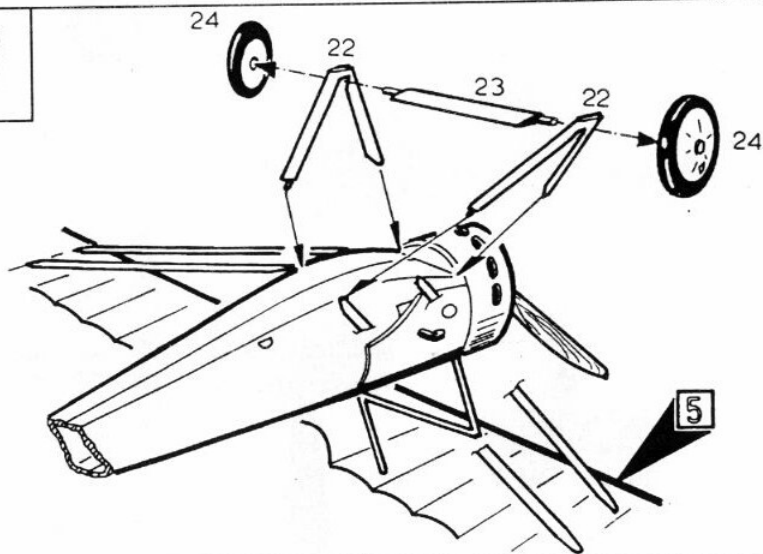
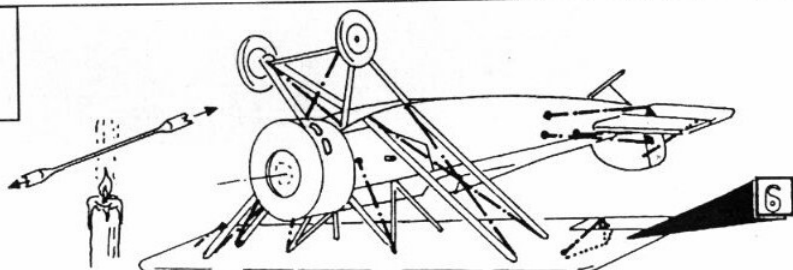
<http://www.modelimex.cz>

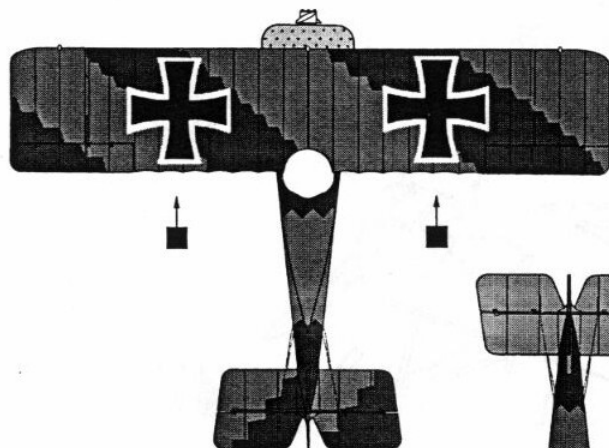
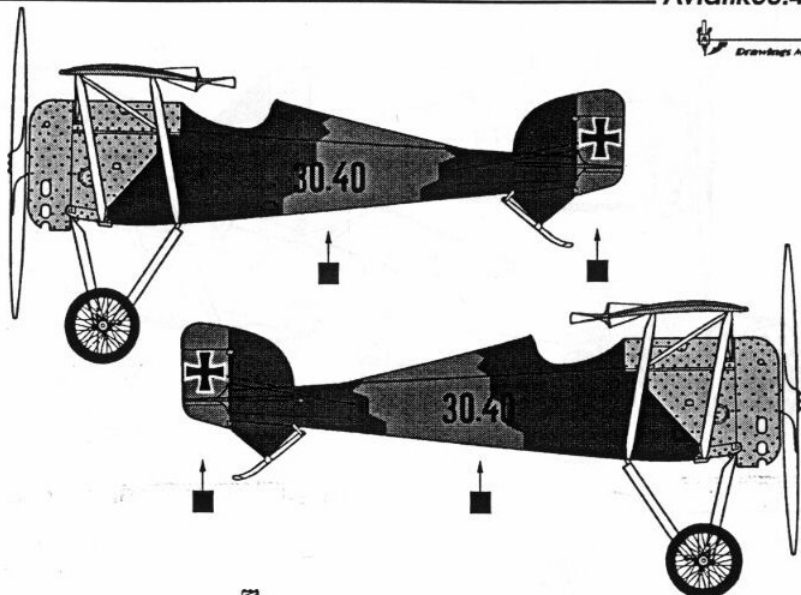
**E-mail: [info@modelimex.cz](mailto:info@modelimex.cz)**

**1****2****3****4**

**5****6****7**



- 
 lakované dřevo / lacquered wood
- 
 lakované plátno / lacquered canvas
- 
 světlé šedá / light grey
- 
 tmavé šedá / dark grey
- 
 hliník / aluminium
- 
 obtlisk / decals

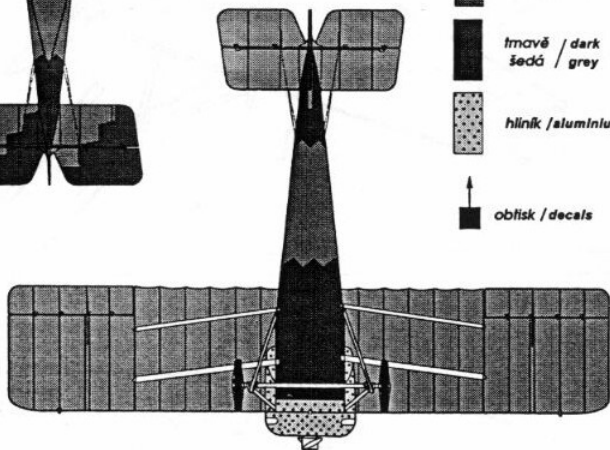

# Österreichische Aviatik 30.40

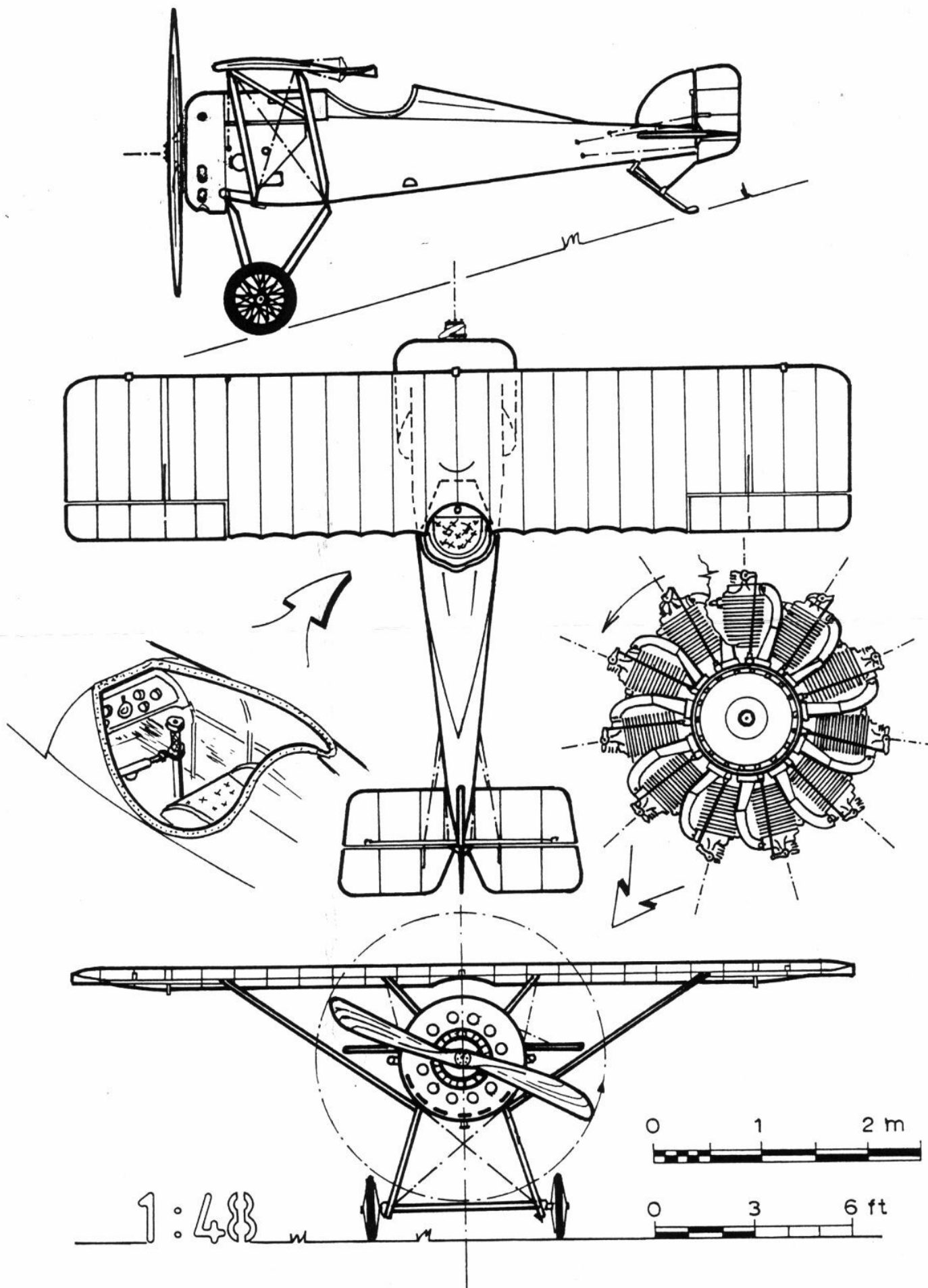

1 : 48

0 1 2 m

0 3 6 ft