

Workable leaf springs

for Land Rover LWB series

VMD35022

1/35 scale photoetched detail set

for Tamiya kits

adaptable to all kits



minor 

Made in Europe 2013

www.minor-web.com

CAUTION This product contain small pieces,
not suitable for childrens under 10 years



 Bend Symmetrically (Both sides)  OP Optional  I Put into  Original parts  minor kit parts  Scratchbuilt or modified parts  R Repeat on all similars

Is better to bend the spring before to mount the leaf grips and before to mount on the axis.

Later you can adjust the spring curvature

FRONT SPRING

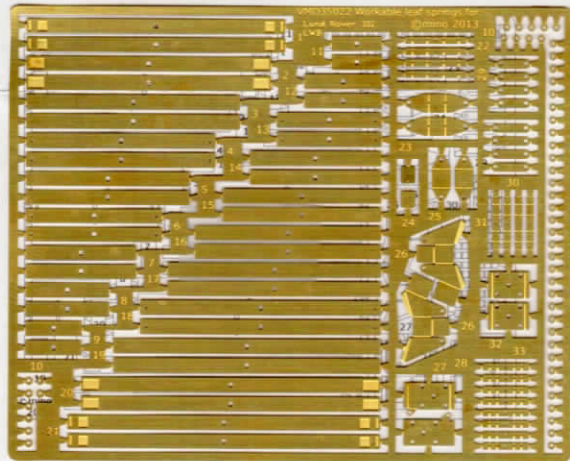
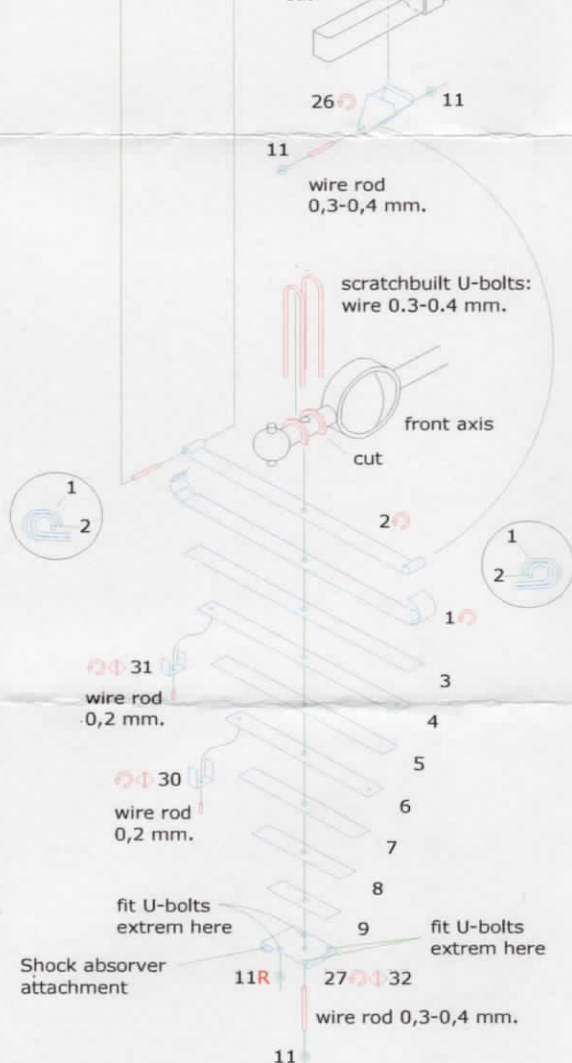
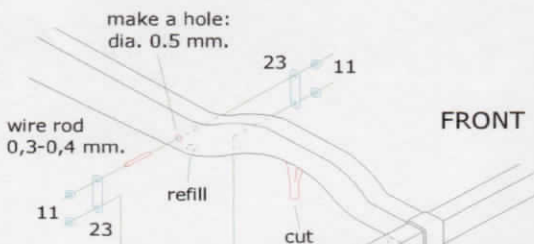

REAR SPRING

