



# PD DECALS

1/48 SCALE

SPAD XIII (part 1)

48 - 008

**IMPORTANT : PLEASE READ THE DIRECTIONS FIRST**

## DIRECTIONS

Study the subject you wish to model closely, and be sure you have properly identified the decals you will require. Please note that this sheet covers both Bleriot and Kellner built aircraft, which were finished in subtly different camouflage schemes.

Tweezers and a clean paint brush can be useful tools when applying decals. Decal setting solutions may also be used with this product, but their manufacturers directions must also be observed. Better results can be achieved by applying decals to a clean gloss surface.

It is recommended that these decals be applied one at a time. Cut out the decal you wish to apply, dip into water, and put aside. When the decal slides freely on its backing paper, it is ready for application. The decal should be slid directly onto the model; wetting the area receiving the decal with water or setting solution will assist final positioning of the decal.

## KITS

Dragon - SPAD XIII

## REFERENCES

- 1) "SPAD 13.C1 - Windsock DataFile 32", by J M Bruce, Albatros Publications, Hertfordshire, England, 1992
- 2) "Windsock International", Vol.6, No.4, July/Aug 1990, Albatros Publications, Hertfordshire,
- 3) "Windsock International", Vol.6, No.5, Sept/Oct 1990, Albatros Publications, Hertfordshire,
- 4) "SPAD FIGHTERS In Action", by J C Connors, Squadron Signal Publications, Texas, 1989
- 5) "AEROPLANE MONTHLY", Vol.19, No.8, August 1991, IPC Magazines Ltd, London
- 6) "Project Butterfly - The standard French Camouflage System of 1918", by A D Toelle, H D Hastings and B F Hardesty, parts 2 and 3, published in "Cross and Cockade Journal", Vol 13, No 2, Summer, 1972 and Vol 13, No 4, Winter, 1972

The above references are referred to in the instructions by their number.

**NOTE : Americal Gryphon produces decal sheets with USAS and French roundels which may be useful with these decals.**

The kind assistance of Mr. R. Guest is gratefully appreciated.

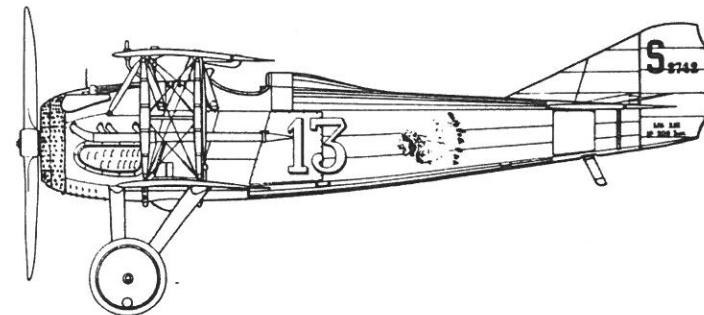
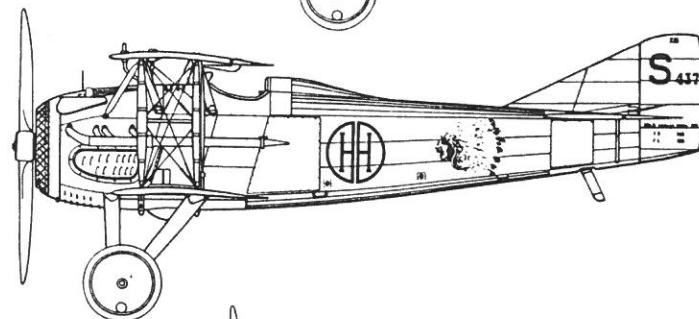
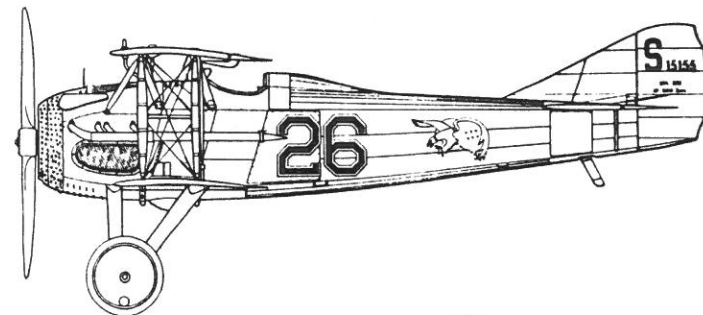

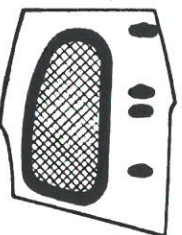
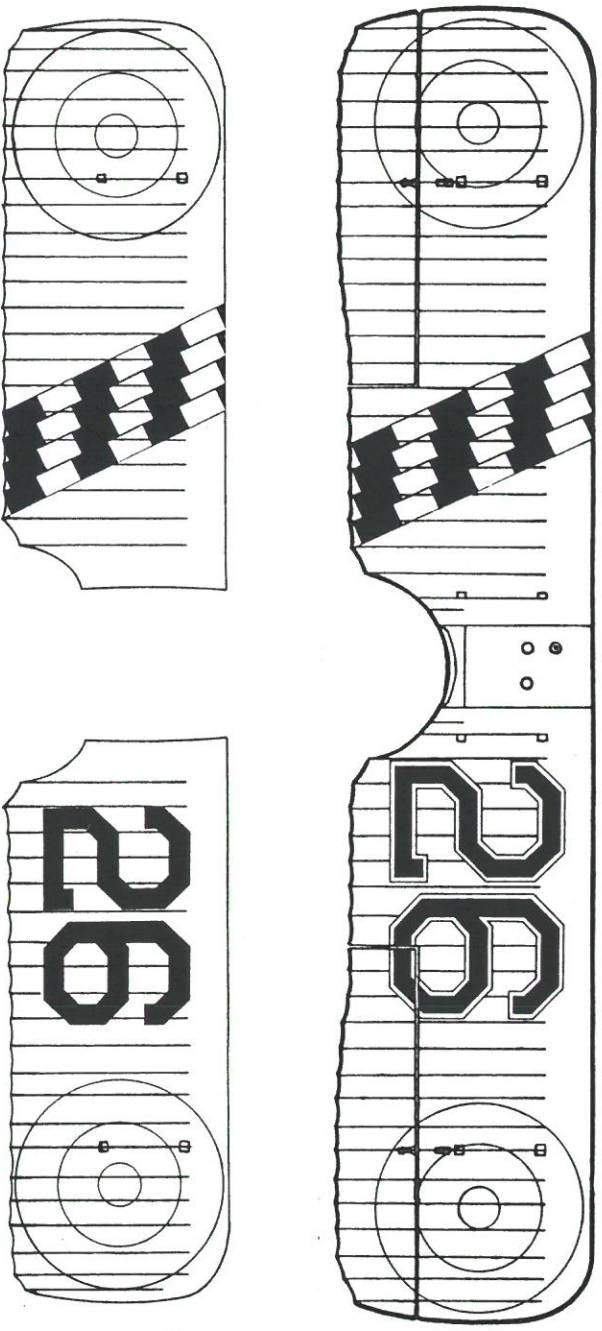

this panel natural metal  
note dark rim to mesh

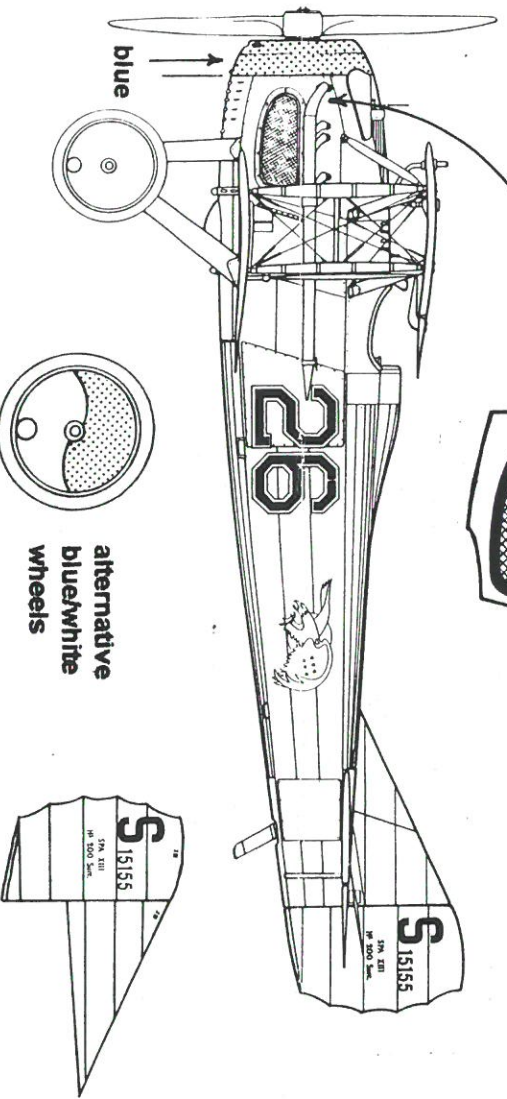

alternative  
blue/white  
wheels

### 1) SPAD XIII, S15155, 2nd Lt Frank Luke, 27th Aero Sqn, 1918

The exploits of Frank Luke have acquired a legendary status. Renowned as a balloon "busting" specialist, he claimed 18 victories, 14 of these balloons, and all during September 1918. He claimed 3 balloons on the 15th, and 2 balloons and 3 aircraft on the 18th. He ultimately met an untimely demise when he was mortally wounded on 29 September and bled to death next to a stream behind enemy lines. The actual markings of his aircraft have proved elusive - those presented here are based on the cover illustration and photo shown in Reference no. 1.

This was a Bleriot built machine, and was camouflaged according to their pattern. The cowling ring was Blue, and the side cowling panels were a light colour, probably natural metal. Struts are a dark colour, either Brown or Dark Green, with the undercarriage and wheel discs in the undersurface colour, probably Pale Yellow. The wheels may have been finished in Blue/White at a later time. The number "26" has been provided in two parts for the fuselage and upper wings. The White should be applied first, then the thinner Black inner part over the top. The lower wing "26" is Black (the thicker Black "26"). The eagle emblem faces forward on both sides. Red/White/Blue stripes should be applied to the rudder (Red forward) before applying rudder decal. Note a small "XIII" is carried on the upper right side of the fin and rudder. The Black/White check decal for the wings will not exactly fit the trailing edge; when it has dried completely, excess decal over the scalloped trailing edges can be removed by CAREFUL use of a very light grade wettable sanding paper. Note roundels on upper wings are same size as lower wings.

References : No 1 Inside/outside front cover

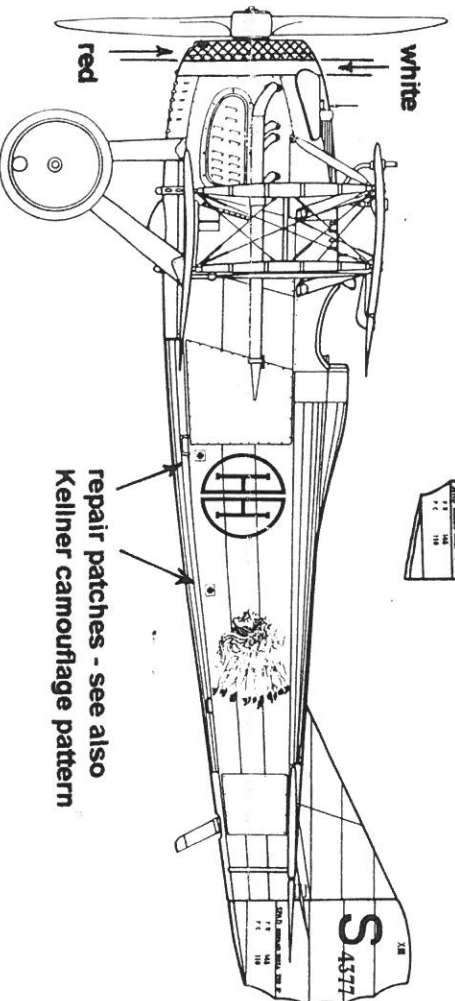
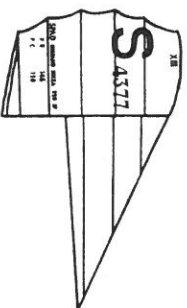
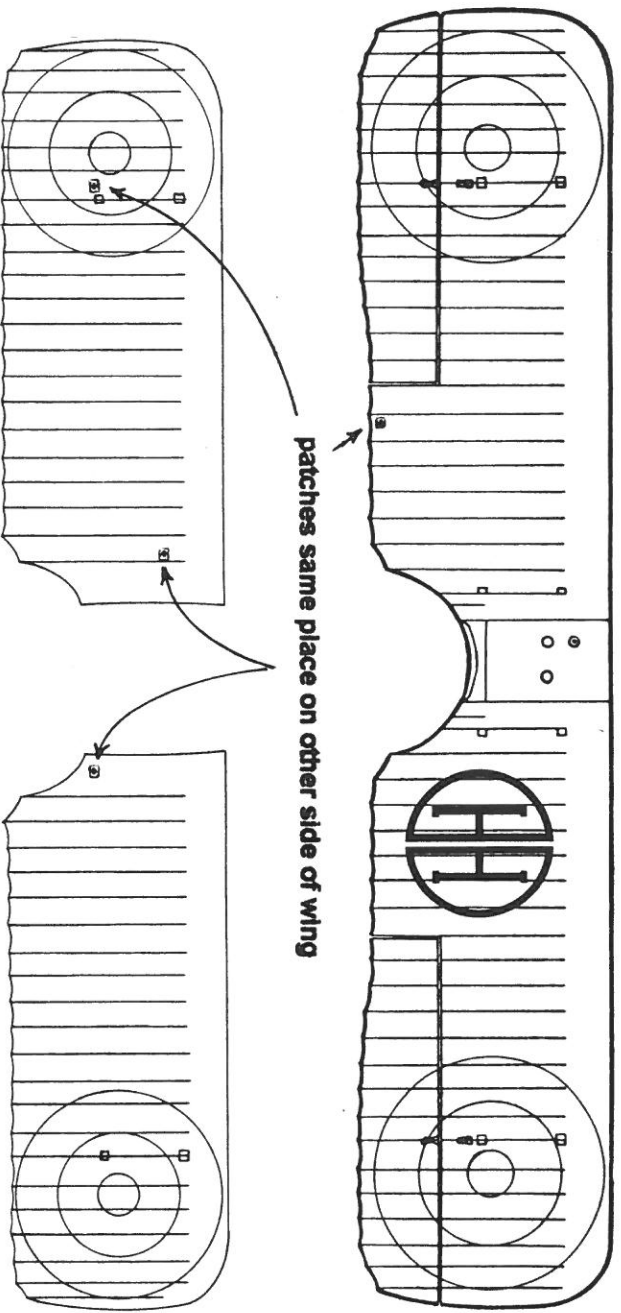

## 2) SPAD XIII, S4377, 1st Lt Charles Dolan, 103rd "Lafayette" Aero Sqn, 1918

Charles Dolan joined the Lafayette Escadrille in May 1917 and was still with the Escadrille when it became the 103rd Aero Squadron in February 1918. He returned to the USA in June 1918 as an instructor with one victory to his credit, having shot a Fokker off the tail of 1st Lt Gorman Lamer on October 12. He was destined to be the last surviving member of the Lafayette Escadrille. This scheme represents the restored aircraft of the Memorial Flight Association at Meudon in France, which was finished in the colours of Charles Dolan.

A Kellner built machine, it has been camouflaged according to their pattern. The cowling ring is Red and White, with Red forward. The personal emblem was an "H" in a divided circle; the Red half of the "H" is forward on both sides of the fuselage, and to the right on the upper wing. Struts are natural wood. The undercarriage and wheel discs are finished in the undersurface colour of Light Grey. The aircraft has repair patches on the fuselage and wings, a white square with an "Iron Cross". Patch positions should be carefully noted, as they differ on each side of the fuselage. On the upper and lower wings the patches correspond with each other for upper/lower surface of each wing. Note that more patches have been provided than will be required, and they should be cut off one at a time. The Indian head faces forward on both sides. Blue/White/Red stripes should be applied to the rudder (Blue forward) before applying the rudder decal. French national markings are carried on the wings of this aircraft.

References : No. 3 cover, p. 19 ; No. 5 pp. 456, 457 and 476

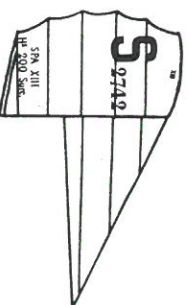
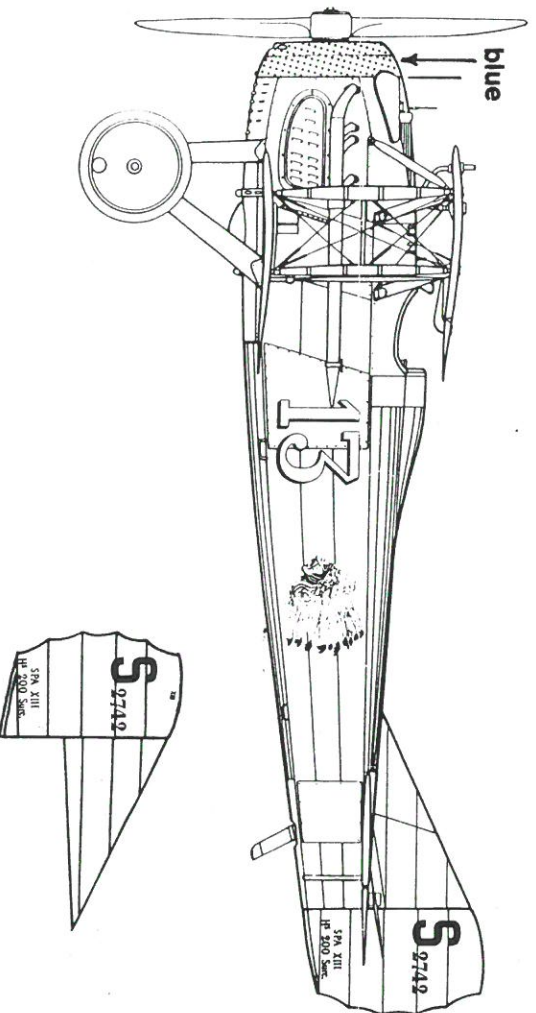
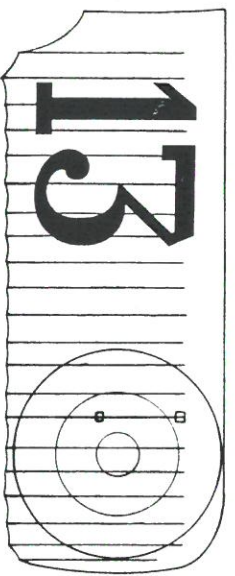
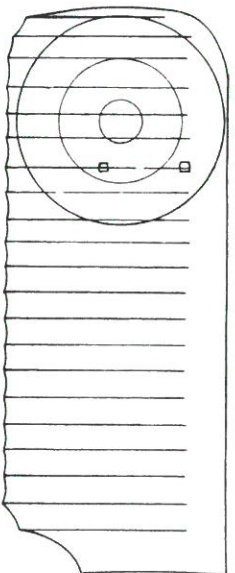
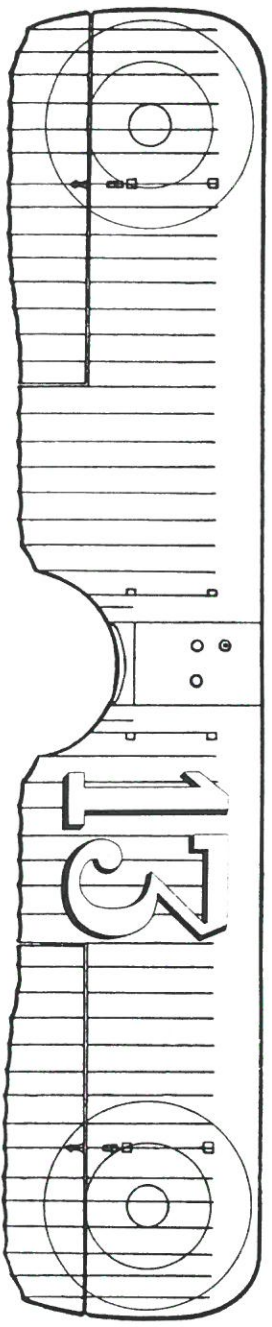

### 3) SPAD XIII, S2742, 1st Lt Gorman Larner, 103rd "Lafayette" Aero Sqn 1918

Gorman Larner joined the 103rd Aero Squadron in June, 1918, having served with Spa. 86 since November 1917. He finished the war with the 103rd, and seven victories to his credit. He went on to serve with President Wilsons staff in Paris, before serving as Air Attache at the US Embassy in London in 1940. He retired from the USAF with the rank of Colonel.

This was a Bleriot built machine, and was camouflaged according to their pattern. This aircraft has been illustrated with a White cowling ring, but photographic evidence suggests Blue may be more likely. Struts are a dark colour, either Brown or Dark Green. The undercarriage and wheel discs are painted in the undersurface colour of Pale Yellow. The number "13" has been provided in three parts for the fuselage and upper wings. The White "13" should be applied first, then the Yellow, then the Black "shadow" over the top. The lower wing "13" is Black only. The Indian head faces forward on both sides.

Blue/White/Red stripes (Blue forward) should be applied to the rudder before applying rudder decal. Note roundels on upper wings are same size as lower wings.

References : No. 2 pp. 23-27 ; No. 4 p. 46

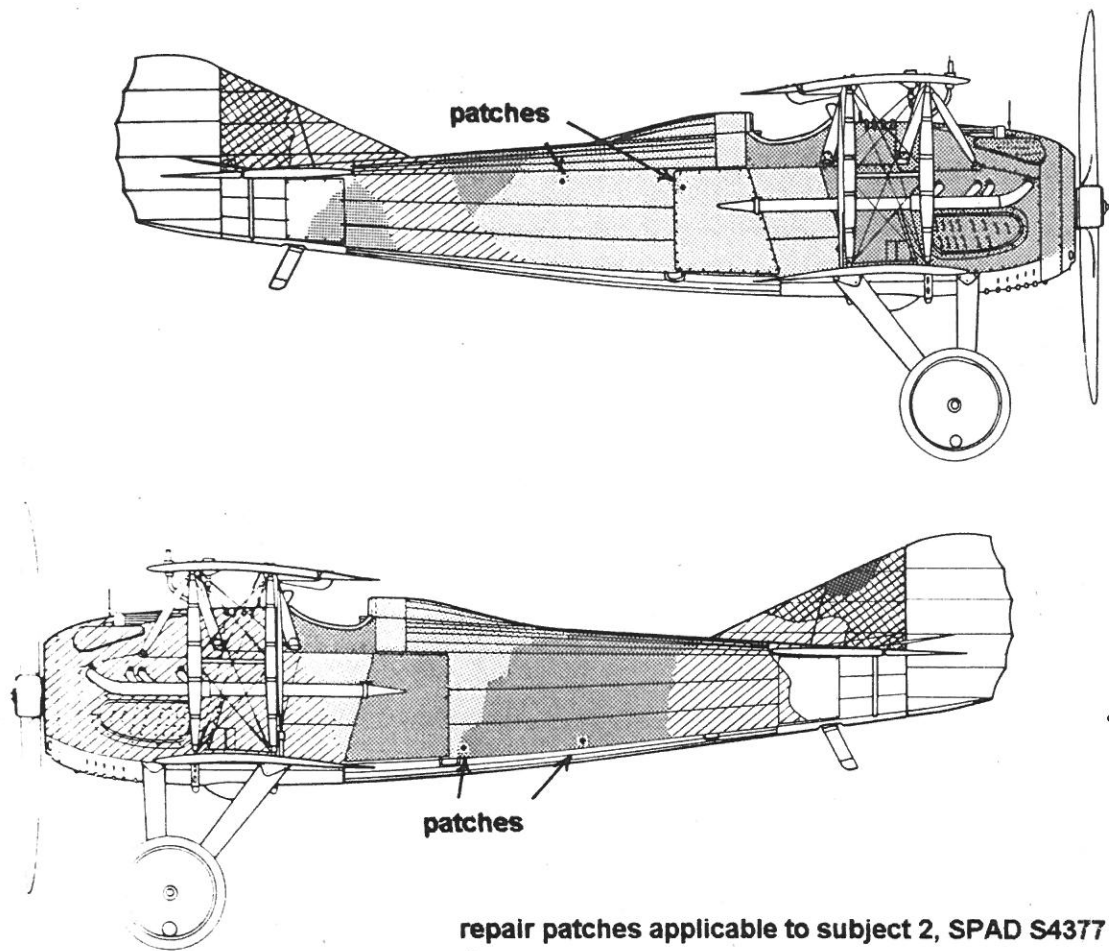

repair patches applicable to subject 2, SPAD S4377

### Typical Camouflage Scheme - KELLNER

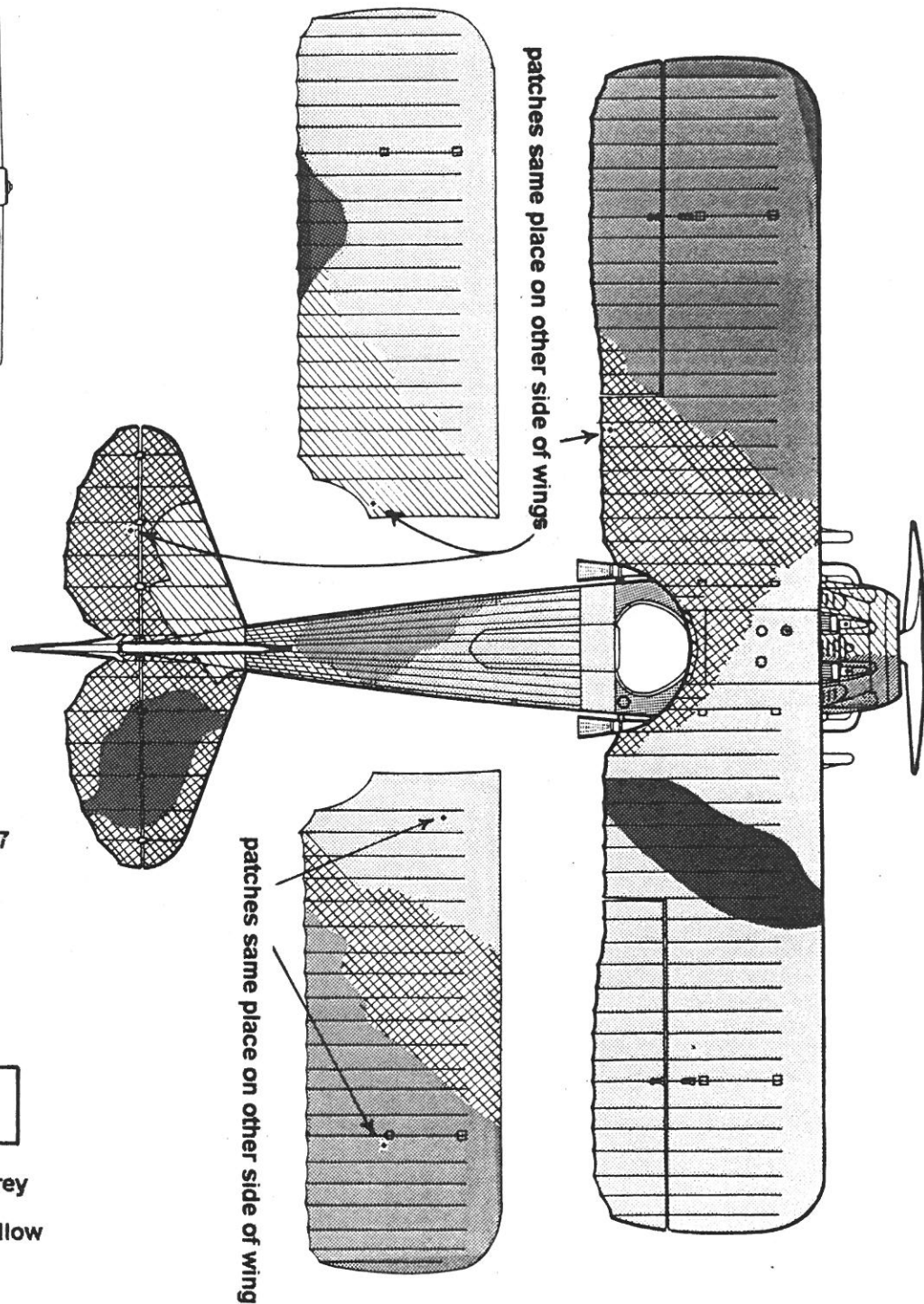
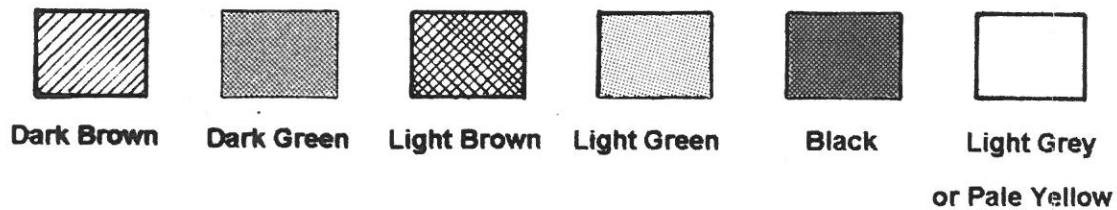

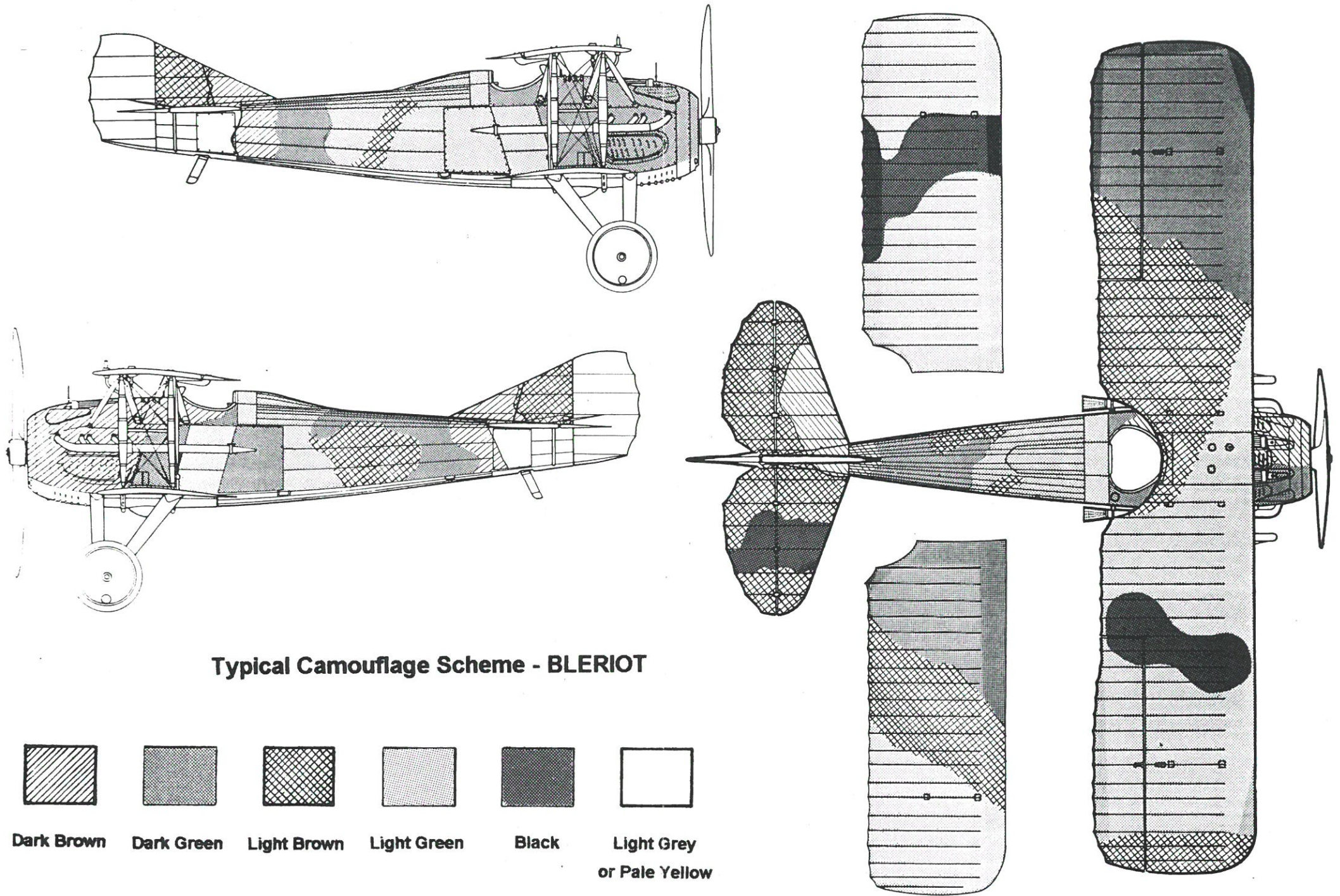

**Typical Camouflage Scheme - BLERIOT**



**Dark Brown**



**Dark Green**

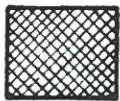

**Light Brown**



**Light Green**



**Black**



**Light Grey  
or Pale Yellow**

26 26

26 26

S 2742

XII  
S 4377

SPAD ROUNDR SILLA 118 P  
P 145  
P 118

S PA XIII  
H 500 Sert.

S 15155  
SPA XIII  
H 500 Sert.

XII  
S 2742

XIII  
S 4377

S PA XIII  
H 500 Sert.

SPAD ROUNDR SILLA 118 P  
P 145  
P 118

S 15155  
SPA XIII  
H 500 Sert.

S 13

S 13



S 13

S 13

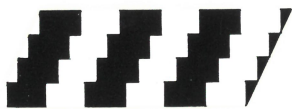

LOWER WING



UPPER WING

13

