



US ARMY

HH-60L MEDEVAC

IN 1/48 SCALE



MINICRAFT MODEL KITS

Legends in the making

The importance of the Medevac helicopters became clearly evident during the recent natural disasters, such as the Asian tidal wave and the violent hurricanes that devastated the southeastern United States. Among the units responding to the flooding of New Orleans was the 146th Medical Company (Air Ambulance). This West Virginia National Guard Unit has been trained just for such emergencies. One of the rescues demonstrates the typical actions of the this specialized unit.

A family marooned on a truck in the rising flood was discovered and a medevac HH-60L Black Hawk was directed the site. It was dark, and the crew was relying on night vision goggles to locate the victims. The wind and clouds made it difficult to maneuver the big helicopter, and to add to the hazard, there were power lines and to avoid and raging water surging over the vehicle.

The Black Hawk was placed in a hover just 80

feet above the ground and the flight medic was gingerly lowered on the rescue hoist to the floundering truck. The crew used a FLIR infrared scanner to monitor the actions of the medic to determine when the each of the victims could be hoisted into the helicopter.

When all the victims were safely in the helicopter, they were flown to a nearby ground ambulance for any needed treatment, and, after refueling their craft, the crew set out to perform more such mercy missions.

With its two jet engines, and large interior, the design of the HH-60L is ideally suited to such search and rescue missions, as well as other, more hazardous combat roles .

11644

MADE IN CHINA

PARTS LOCATING DIAGRAM

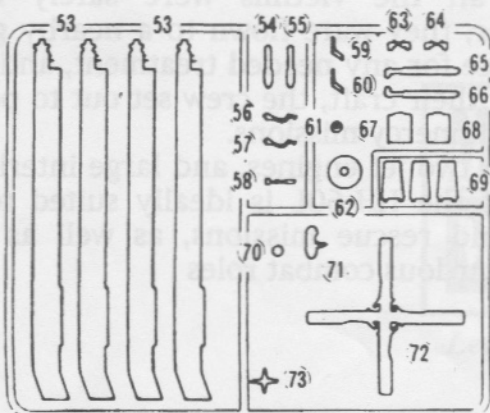
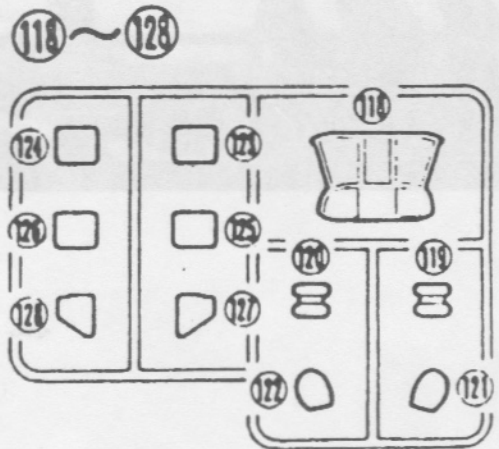
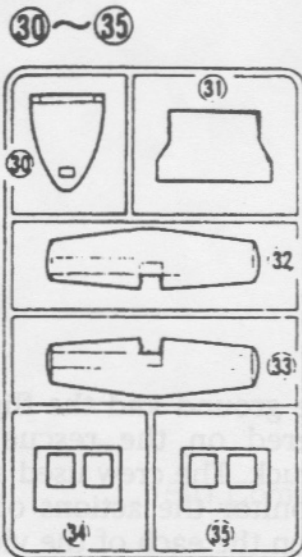
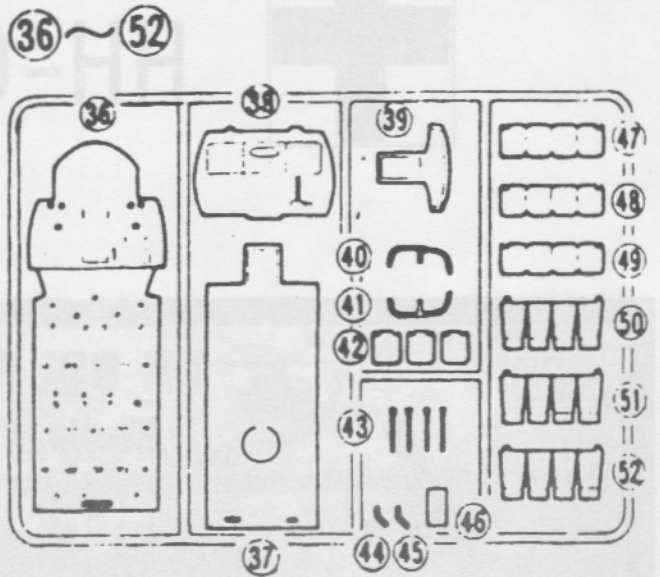
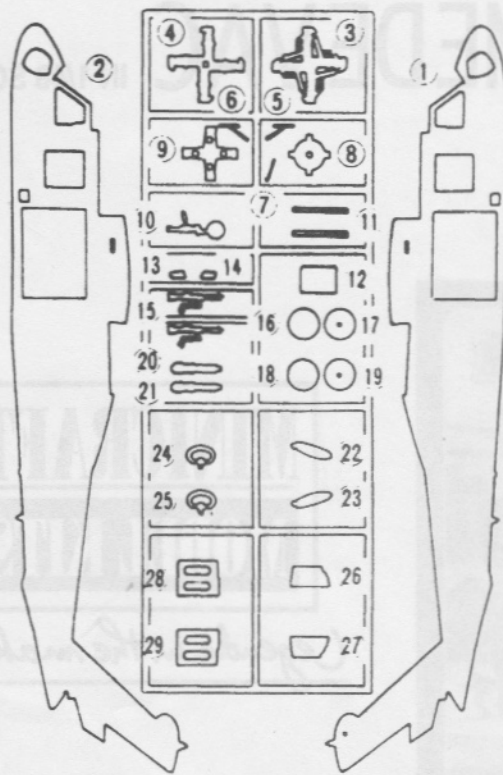

UH60L

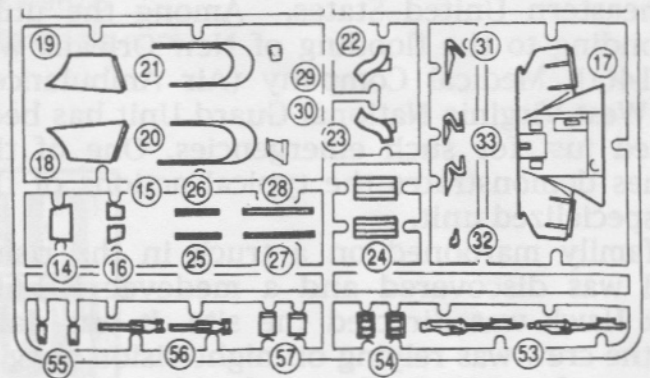

Unused Parts

1 MAIN ROTOR ASSEMBLY



Common Parts
 Color: Olive Drab
 Material: No Plug
 No Color
 No Color
 No Color

Optional Parts
 Color: Flat Black
 Material: Aluminum
 No Color
 No Color
 No Color

3
 Read Operation
 Rubber Inspection
 Verify Measurement
 Repair to Specification
 Repair to Specification
 Repair to Specification

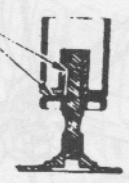
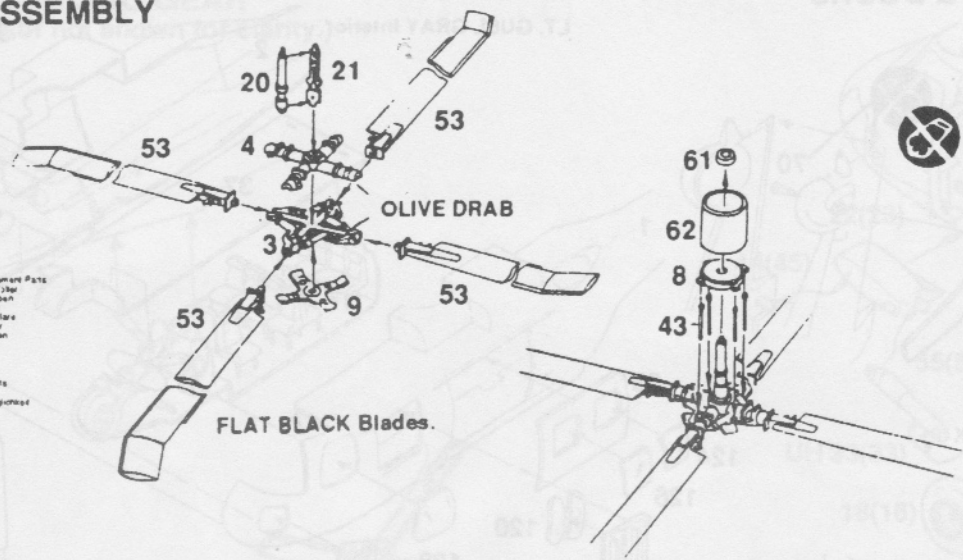

2 INTERIOR ASSEMBLY

LT. GULL GRAY Interior. - SEATS

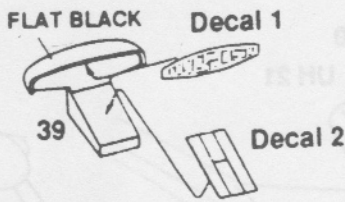
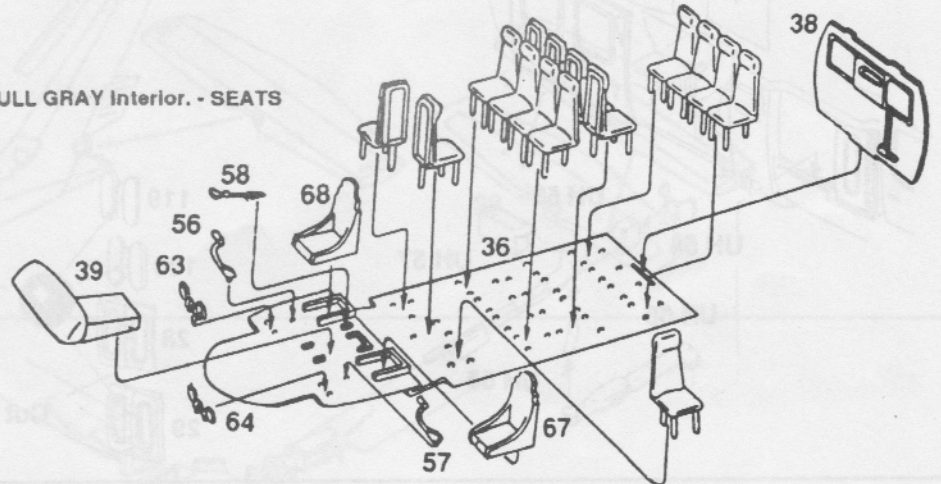
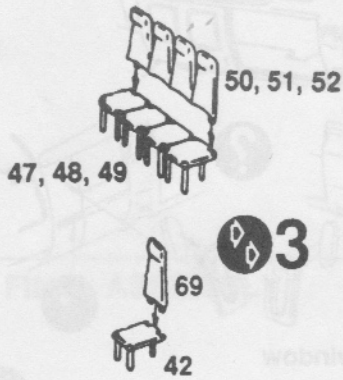

FLAT BLACK Seats, Pedals and Control Sticks. - COCKPIT

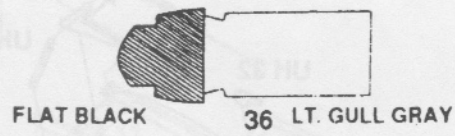

3 EXHAUST ASSEMBLY

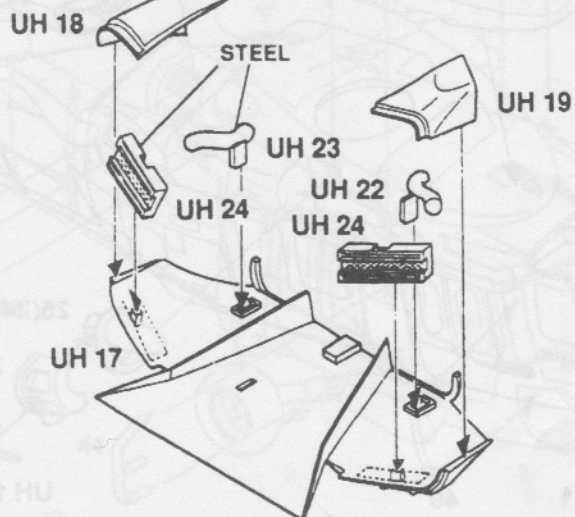

4 TAIL ROTOR & DOORS

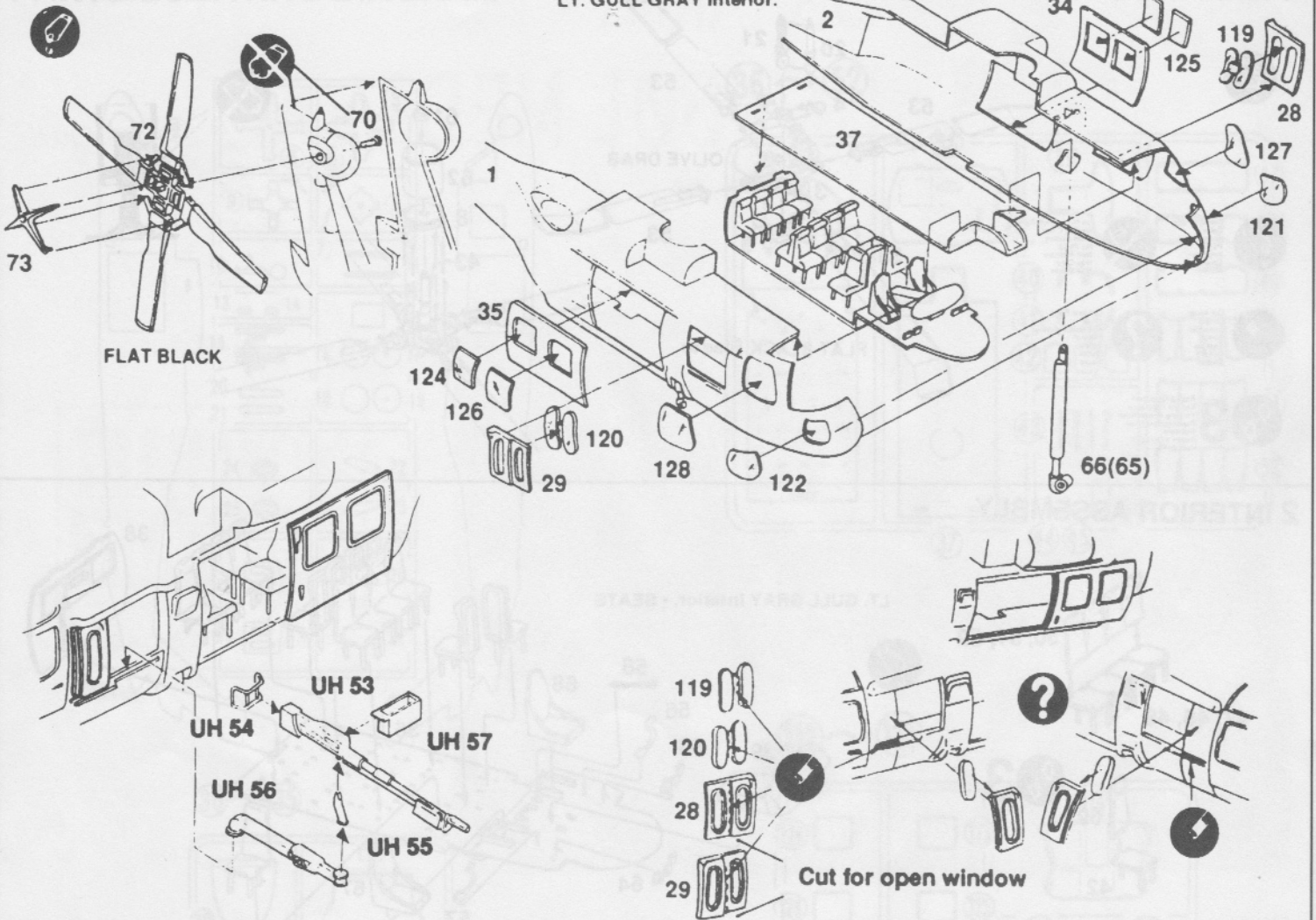

5 FUSELAGE ASSEMBLY

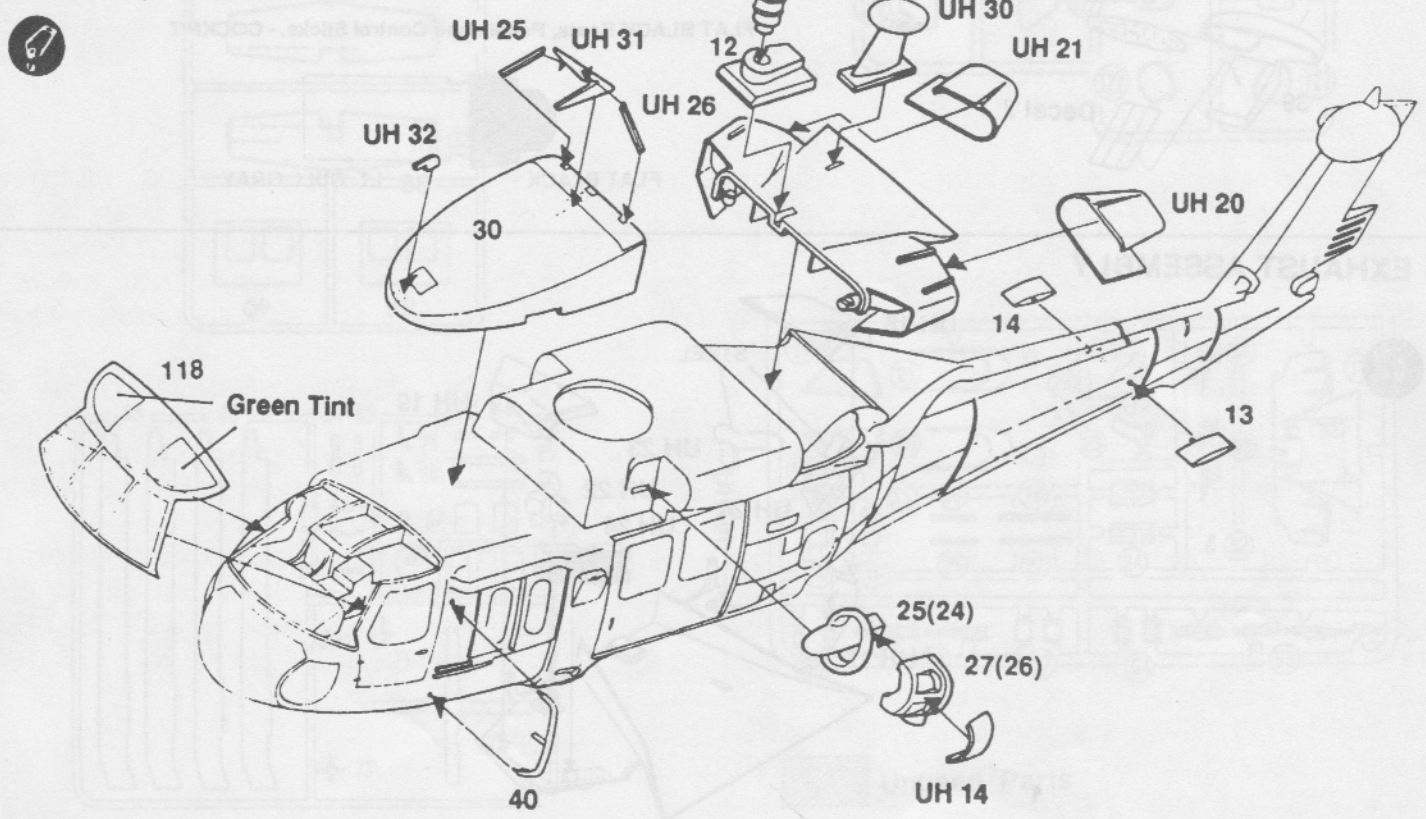

6 STABILIZER & LANDING GEAR

(Tail rotor not shown for clarity.)

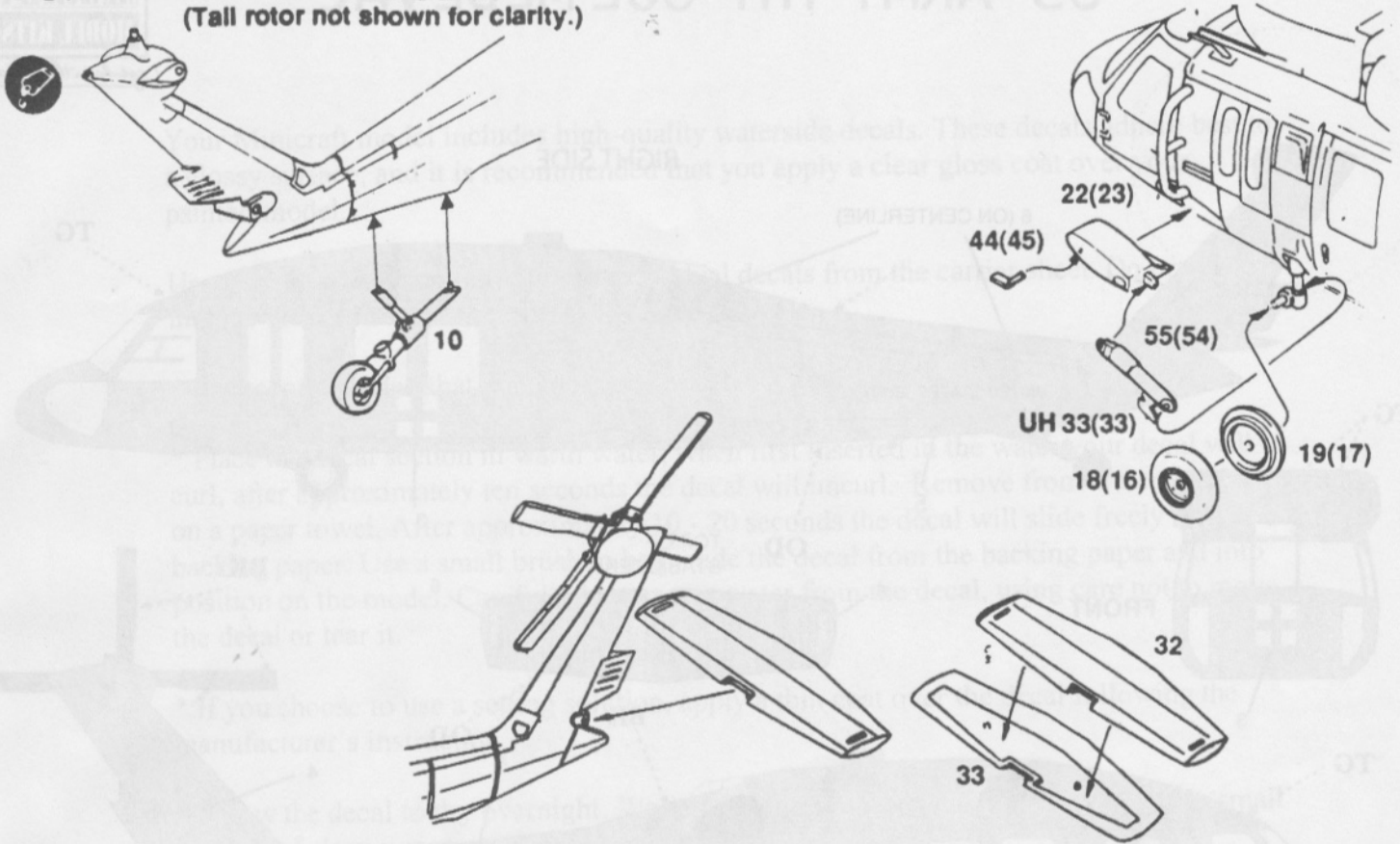

7 FINAL ASSEMBLY

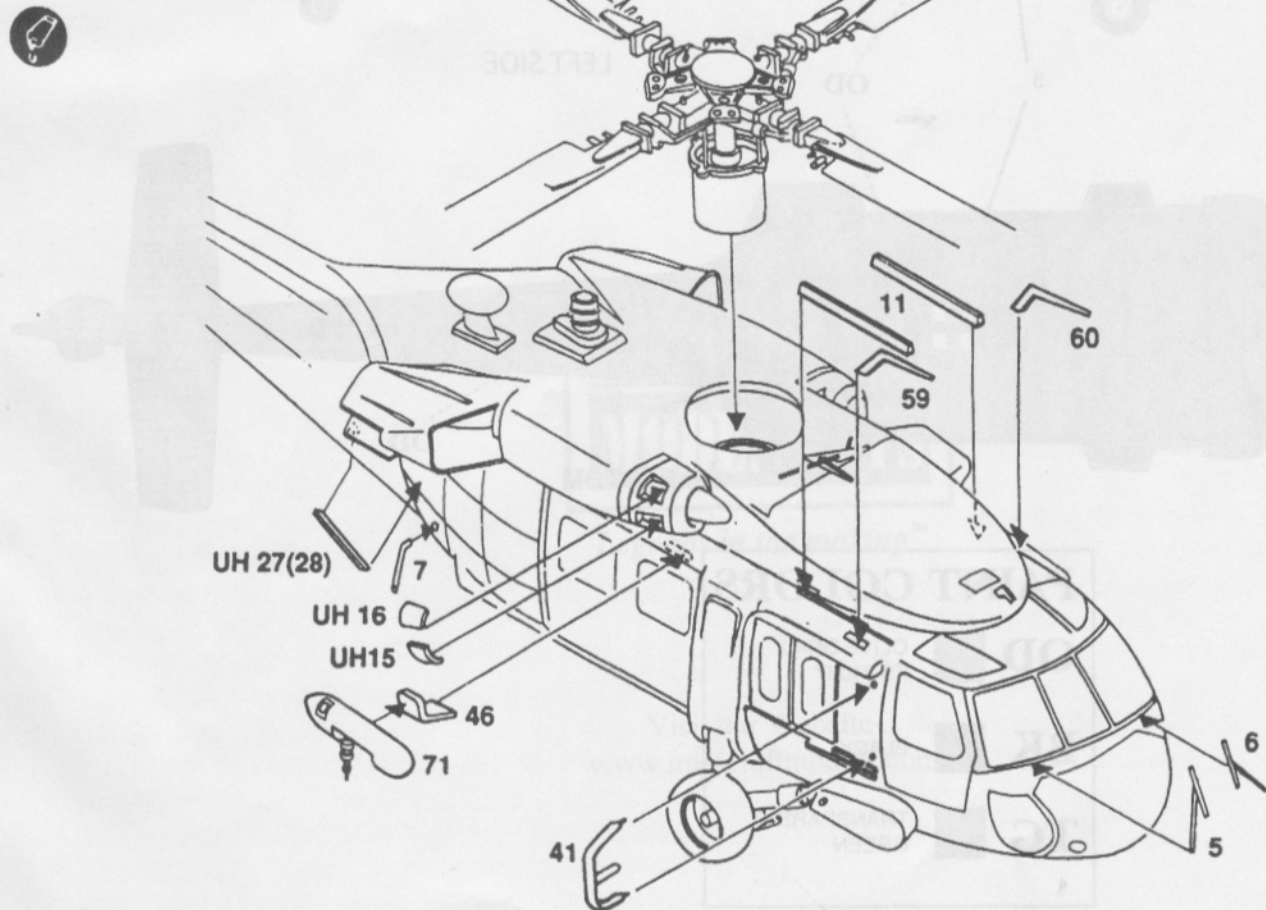

US ARMY HH-60L MEDEVAC

**MINICRAFT
MODEL KITS**

Legends in the making

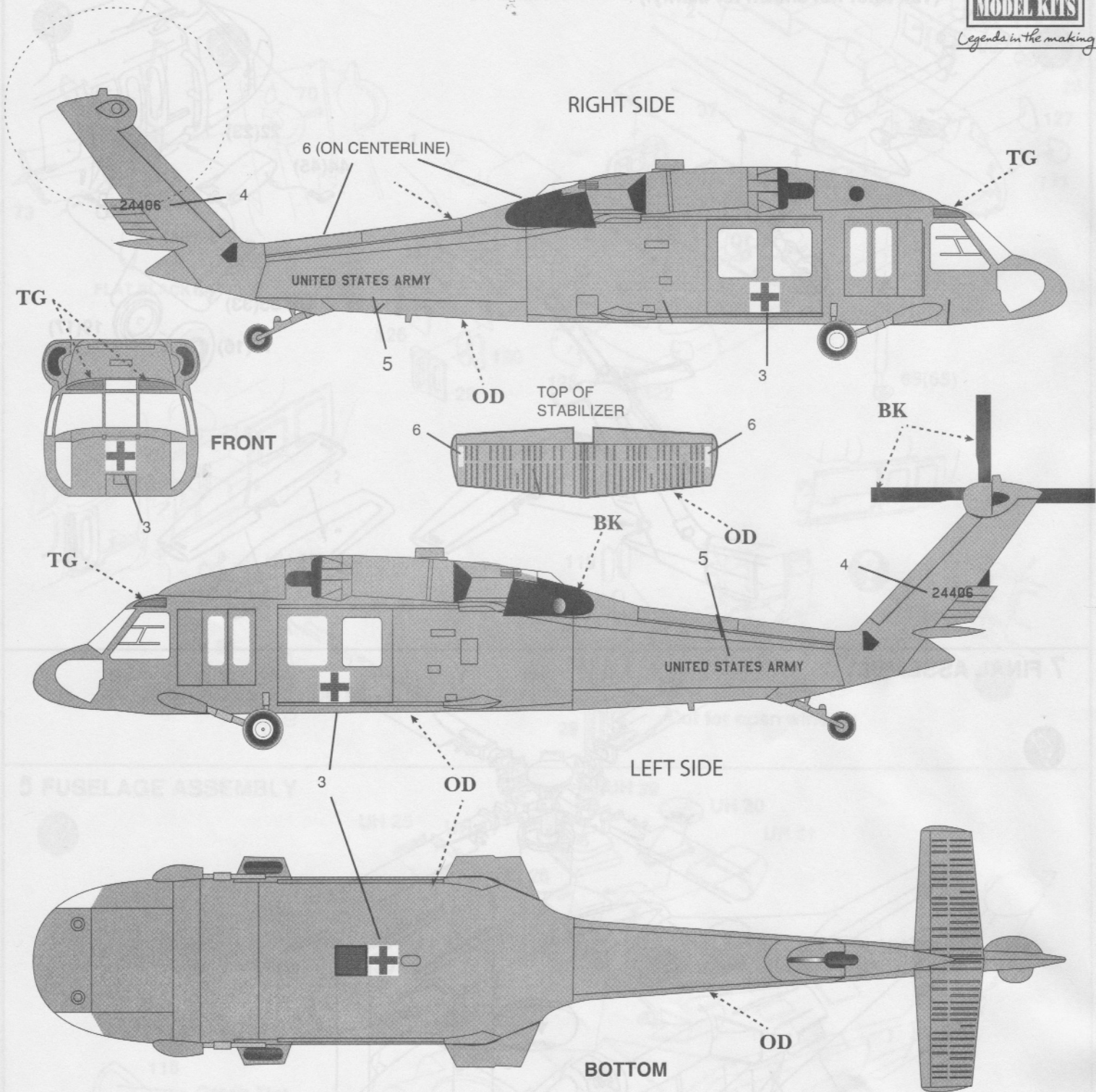

PAINT COLORS	
OD	OLIVE DRAB FS 34087
BK	BLACK
TG	TRANSPARENT GREEN

Your Minicraft model includes high-quality waterside decals. These decals adhere best to a glossy surface; and it is recommended that you apply a clear gloss coat over your painted model.

Use a sharp scissors or knife to cut individual decals from the carrier sheet. Do not cut into the clear film surrounding the individual decals.

* It is recommended that you apply one decal at a time.

* Place the decal section in warm water, when first inserted in the water your decal will curl, after approximately ten seconds the decal will uncurl. Remove from water and lay on a paper towel. After approximately 10 - 20 seconds the decal will slide freely from the backing paper. Use a small brush to help slide the decal from the backing paper and into position on the model. Carefully blot excess water from the decal, using care not to move the decal or tear it.

* If you choose to use a setting solution, apply a thin coat over the decal following the manufacturer's instruction.

* Allow the decal to dry overnight. Wash any adhesive residue off the model with a small amount of clean water and dry thoroughly.

* Apply clear gloss, matte or flat coat to seal decals following the instructions from the manufacturer.

MINICRAFT
MODEL KITS

Legends in the making™

Visit our Website-
www.minicraftmodels.com



Your Minicraft model includes high-quality waterside decals. These decals adhere best to a glossy surface, and it is recommended that you apply a clear gloss coat over your printed model.

Place the decal section in warm water, when first inserted in the water your decal will cut, after approximately ten seconds the decal will unroll. Remove from water and lay on a paper towel. After approximately 10-20 seconds the decal will slide freely from the backing paper. Use a small brush to help slide the decal from the backing paper and into position on the model. Carefully remove the decal from the model, using care not to damage the decal or the model.

If you choose to use a setting solution, apply a thin coat over the decal following the manufacturer's instructions.

Allow the decal to dry overnight. Wash the model with soap and water to remove any excess of clear water used in the application.

Apply clear gloss coat to the model following the manufacturer's instructions.

Apply clear gloss coat to the model following the manufacturer's instructions.

Apply clear gloss coat to the model following the manufacturer's instructions.

Apply clear gloss coat to the model following the manufacturer's instructions.

Apply clear gloss coat to the model following the manufacturer's instructions.

Apply clear gloss coat to the model following the manufacturer's instructions.

Apply clear gloss coat to the model following the manufacturer's instructions.

Apply clear gloss coat to the model following the manufacturer's instructions.

Apply clear gloss coat to the model following the manufacturer's instructions.

Apply clear gloss coat to the model following the manufacturer's instructions.

Apply clear gloss coat to the model following the manufacturer's instructions.

Apply clear gloss coat to the model following the manufacturer's instructions.

Apply clear gloss coat to the model following the manufacturer's instructions.

Minicraft Models
1501 Commerce Drive, Elgin IL. 60123-9304 USA.
Telephone: 847-429-9676
E-mail @ www.minicraftmodels.com



Legends in the making™