

GERMAN TANK DESTROYER Sd.Kfz.173

JAGDPANTHER G1

Early Production

w/Zimmerit

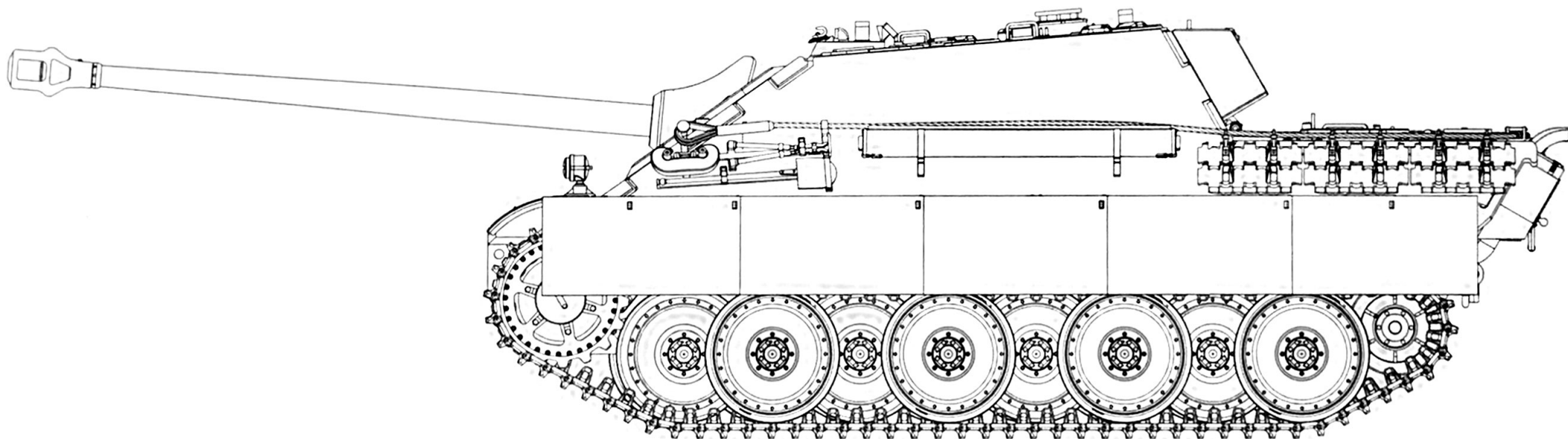

The 8.8cm Panzerjäger Panther Sd.Kfz. 173, or Jagdpanther, was a heavy tank destroyer based on the chassis of the Panzer V Panther and was armed with the same long-barreled 8.8 cm gun as the Tiger II or 'King Tiger', and a single 7.92 mm MG-34 machine gun in the front glacis plate for local defense. The Jagdpanther had a good power-to-weight ratio and a powerful main gun, which enabled it to destroy any Allied tank. Based on the existing Panther chassis, the vehicle did not suffer too many mechanical problems, and had an upgraded transmission and final drive to counter the Panther's main weakness. The Jagdpanther was powered by the 700hp Maybach HL230 P30 V-12 petrol engine and a 7 speed forward, 1-speed reverse transmission system with a maximum speed of 46 km/h (28.6 mph) and a range of about 200 kilometers (99 miles). It was manned by a crew of five: a driver, radio-operator, commander, gunner and a loader.

Two main variants can be distinguished, the earlier (1944 model) G1 with a small internally-bolted main gun mantlet and a modified Panther A engine deck, and the later (1945 model) G2 with a larger, externally-bolted mantlet and a modified Panther G engine deck, though late G1s also had a larger mantlet. Early Jagdpanthers had two vision openings for the driver, whereas late versions had only one. The main gun originally had a monobloc gun barrel, but later versions were equipped with the PaK 43/4 gun with a two-part barrel. Early G1s (to September 1944) were given a distinctive pattern of Zimmerit anti-magnetic mine coating.

A total of 415 Jagdpanthers were produced from January 1944 by three manufacturers; MIAG produced 270 from January 1944 until the end of the war; Maschinenfabrik Niedersachsen-Hannover (MNH) produced 112 from November 1944; Maschinenbau und Bahnbedarf (MBA) produced 37 vehicles from December 1944.

READ BEFORE ASSEMBLY

CAUTION

- Read carefully and fully understand the instructions before commencing assembly. A supervising adult should also read the instructions if a child assembles the model.
- When assembling this kit, tools including knives used. Extra care should be taken to avoid personal injury.
- Keep out of reach of small children. Children must not be allowed to suck any part, or pull vinyl bag over their heads.



Optional



Remove



Instant Glue for Metal



Drill

PAINTS REQUIRED

Color info and profiles by Mig Jimenez

A.MIG 033 Rubber & Tires

A.MIG 035 Dark Tracks

A.MIG 038 Light Wood

A.MIG 041 Dark Rust

A.MIG 045 Gun Metal

A.MIG 098 Crystal Periscope Green

A.MIG 902 Olivgrun Opt.2

A.MIG 318 Dunkelgelb Mid war

A.MIG 014 Schokobraun

A.MIG 036 Old Wood

A.MIG 040 Medium Rust

A.MIG 037 New Wood

A.MIG 008 Dunkelgrau

A.MIG 001 Olivgrun Opt.1

APPLYING DECALS

1. Clean the model surface with a wet cloth.
2. Cut out each decal design from sheet, and dip it in tepid water for 15-20 sec.
3. Hold the backing sheet edge and slide decal onto the model.
4. Move decal into position by wetting decal with finger.
5. Press decal gently down with a soft cloth until excess water and air bubbles are gone.

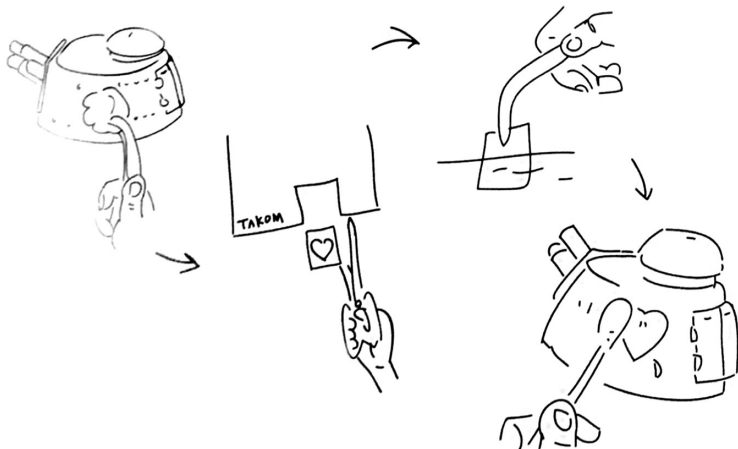

REMOVING PE

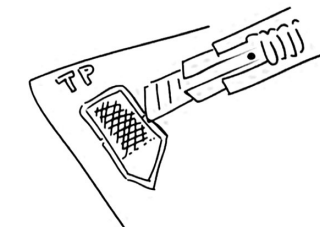

Be careful not to hurt when removing PE parts.

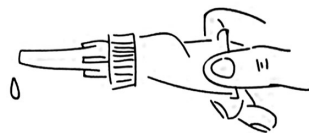

Secure using instant glue (not included).



Finish using file.

PARIS

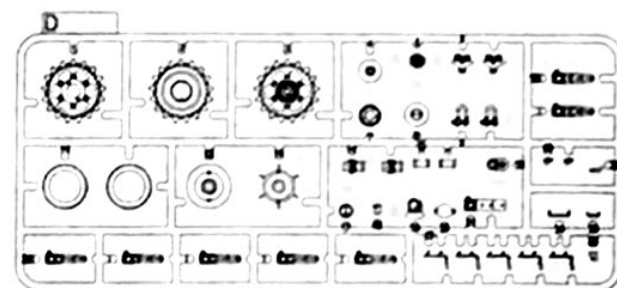
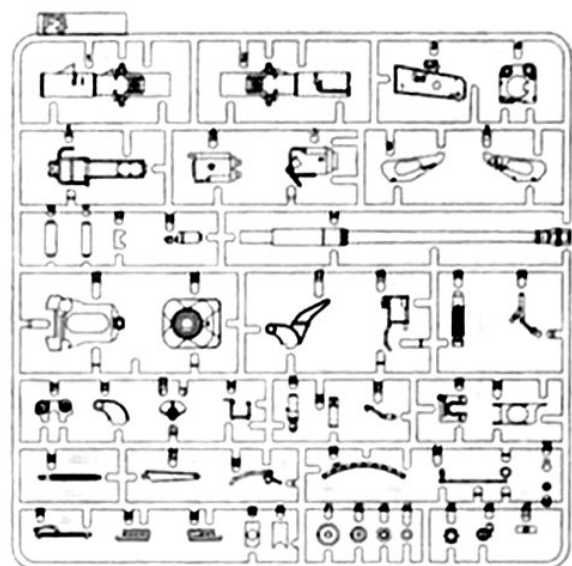
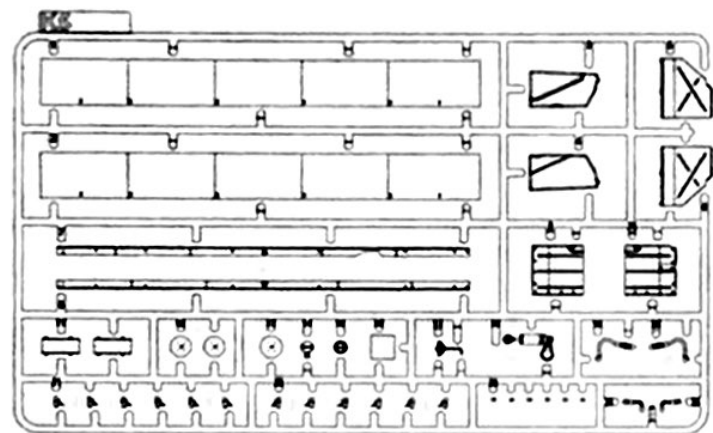
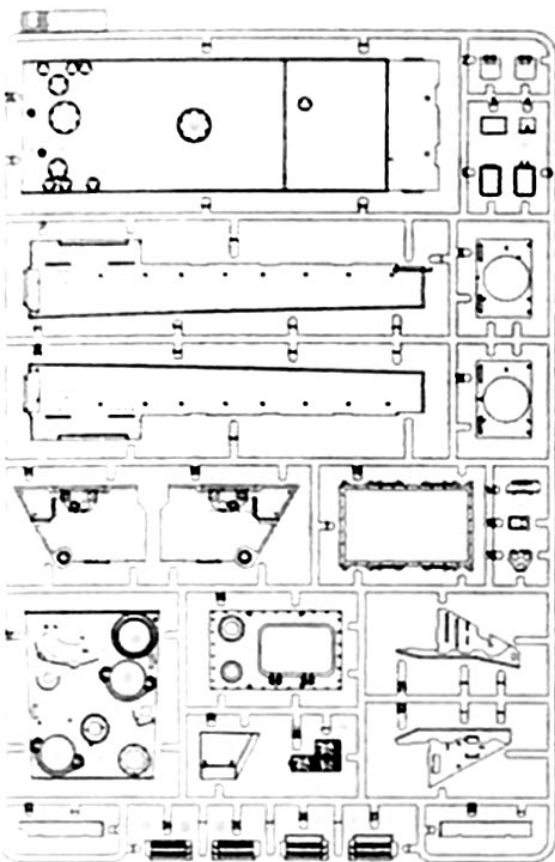

X2

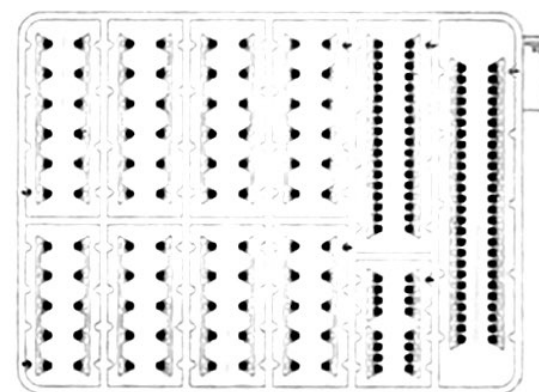
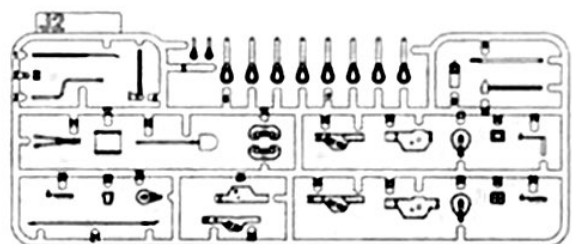
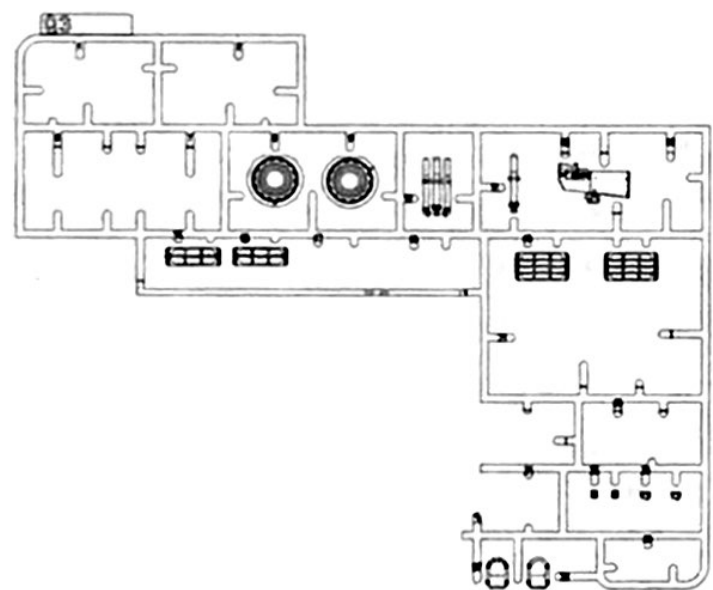
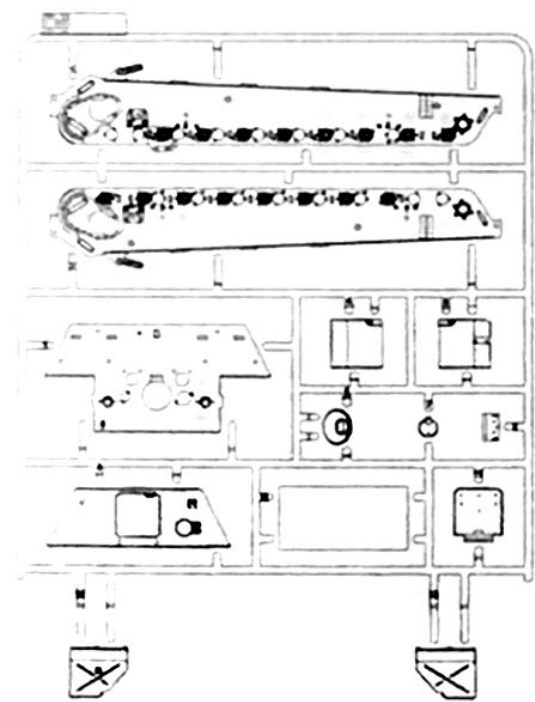
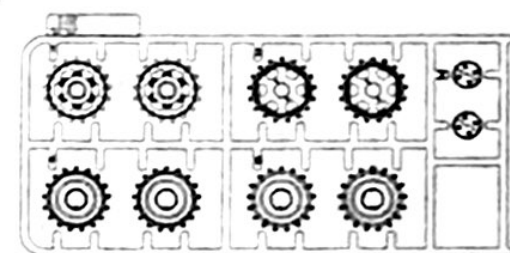

X2

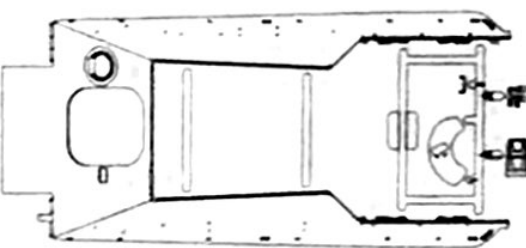

M14

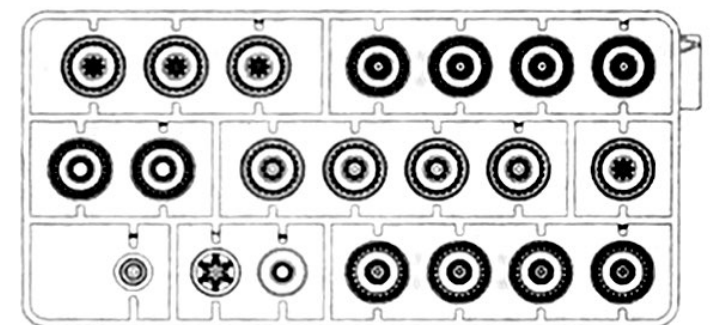
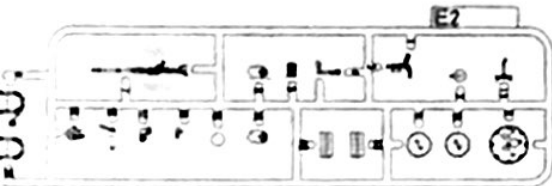

X2

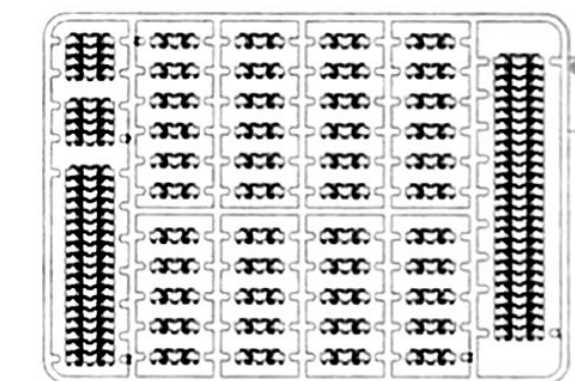
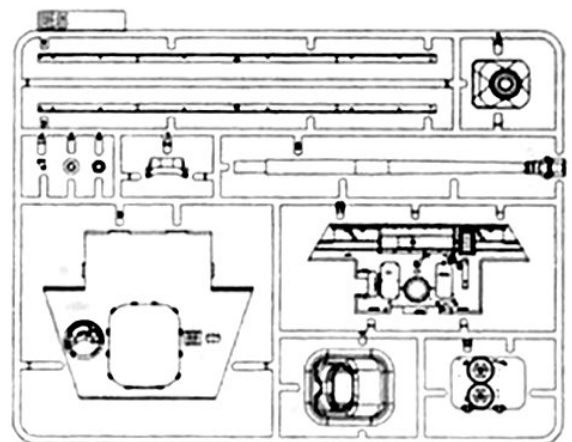

X2

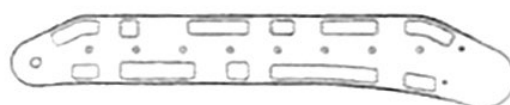

Z2



Z1

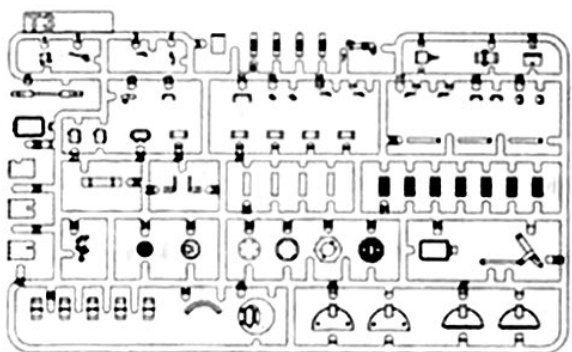
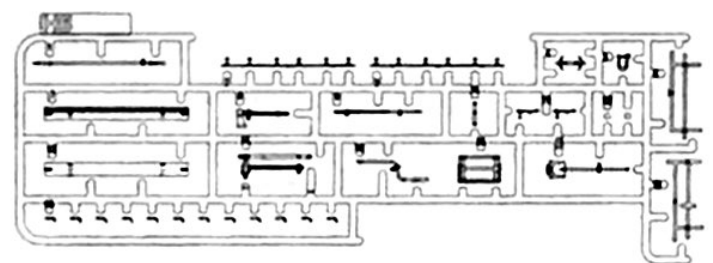

TP

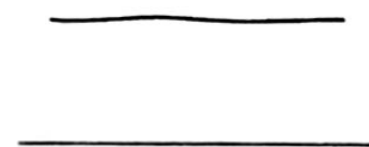

Cable



Decal

1

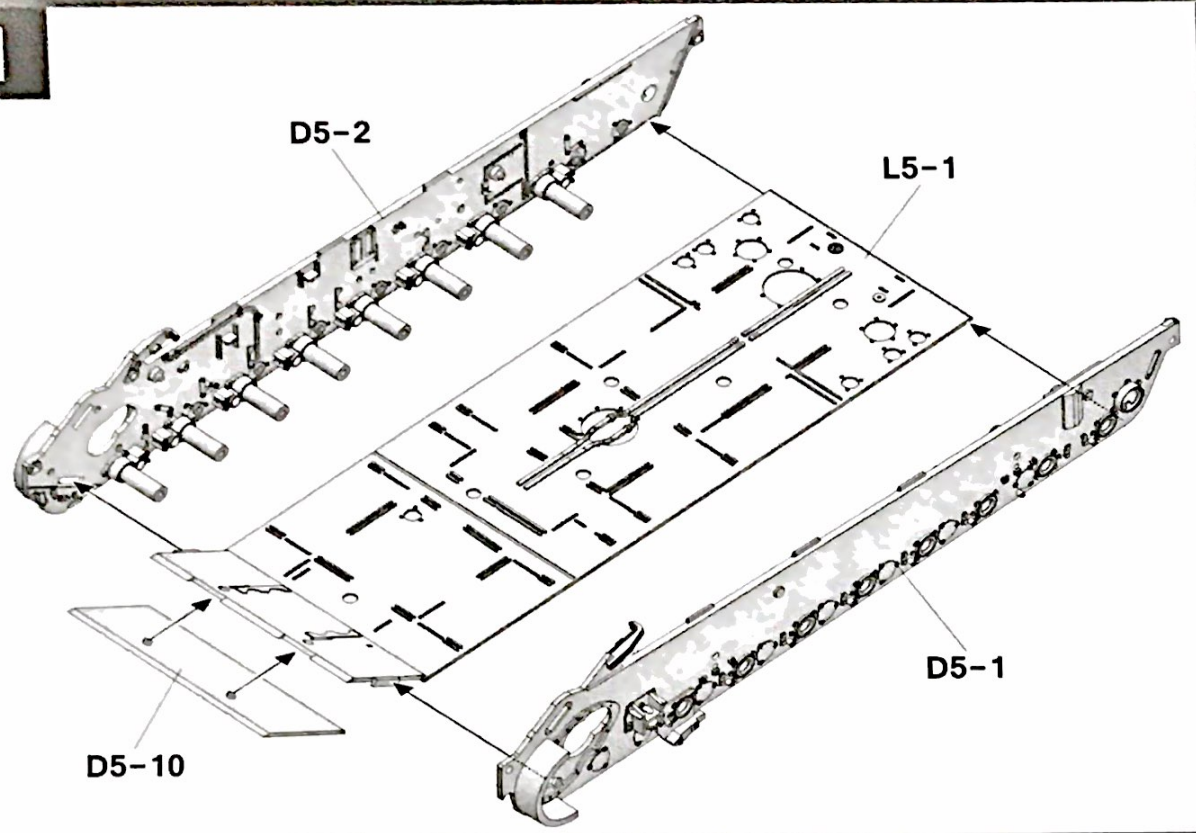

3

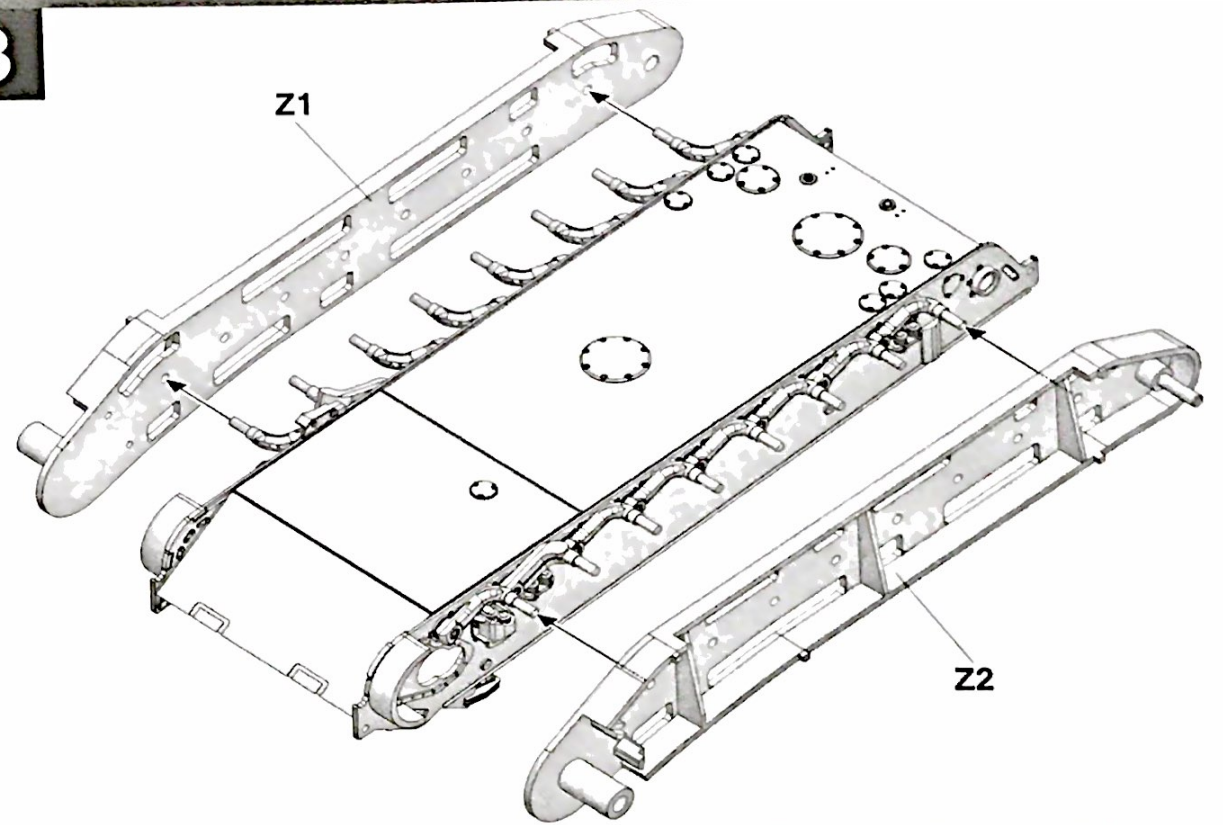

2

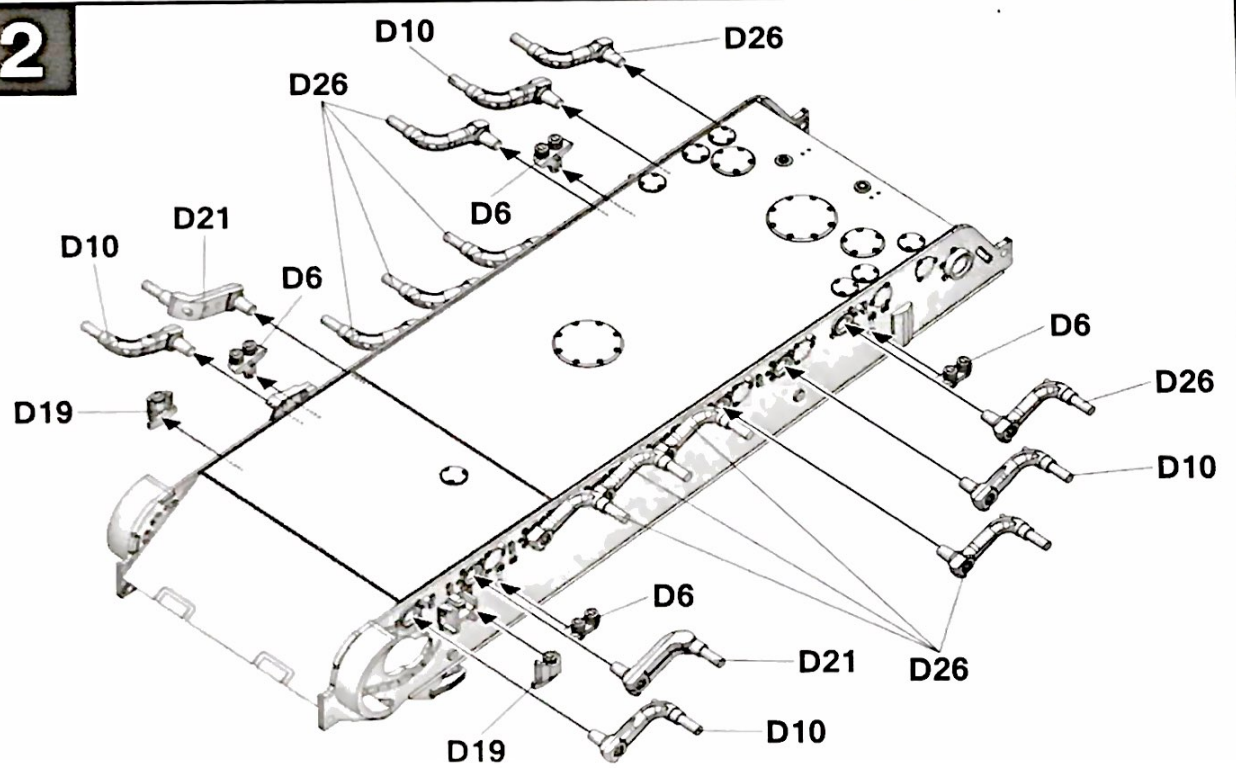

4

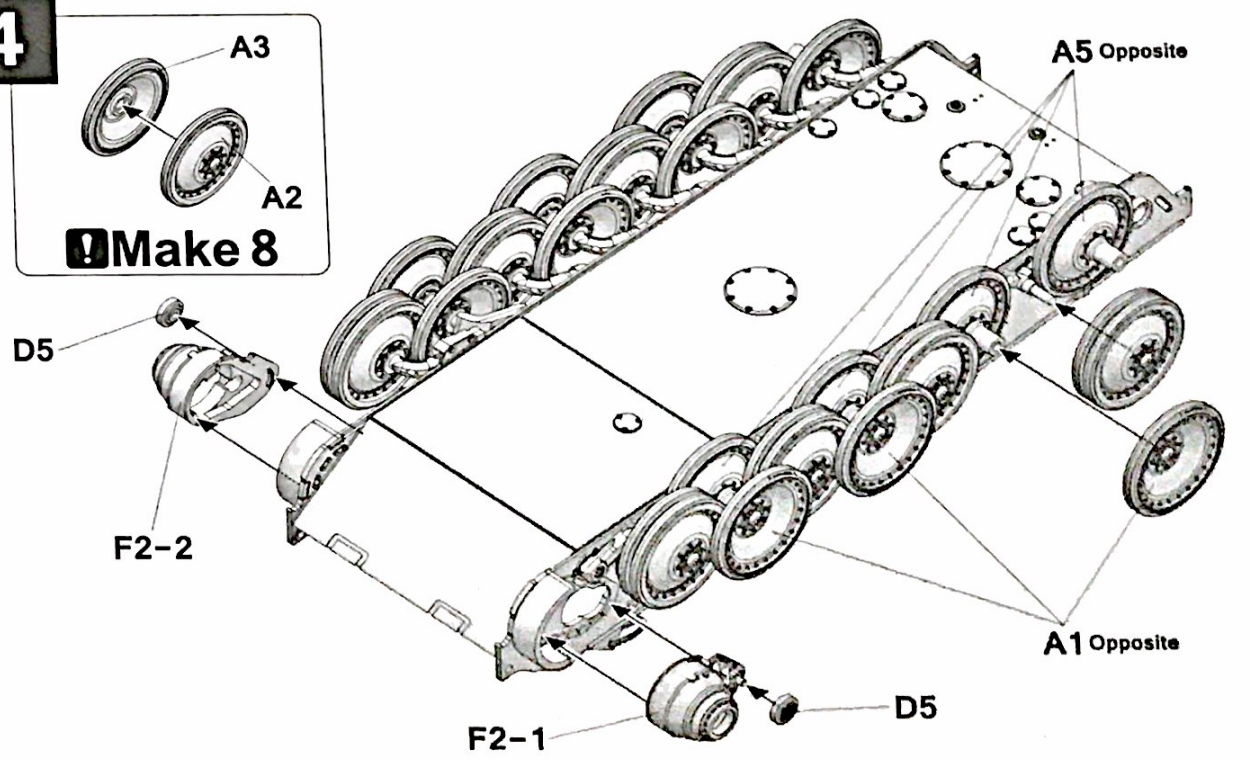

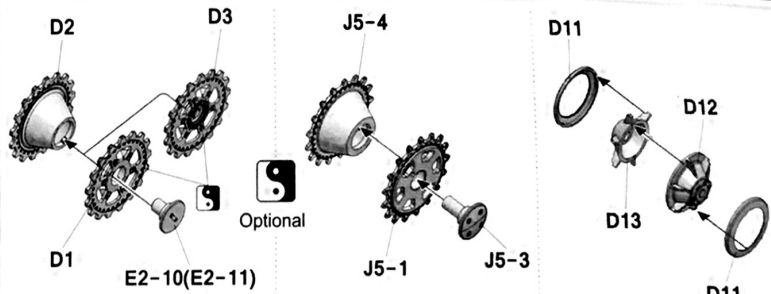
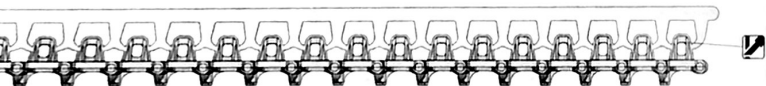
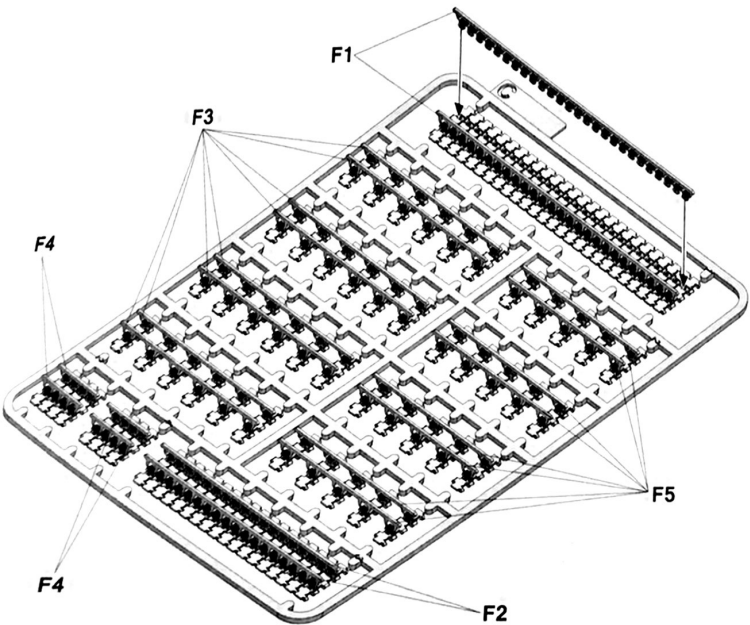
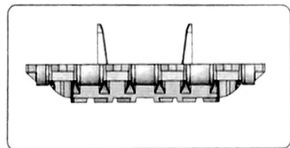

Make 2

Make 2

Make 2

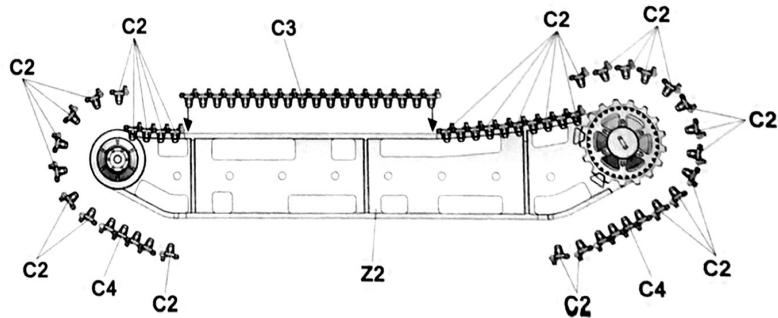
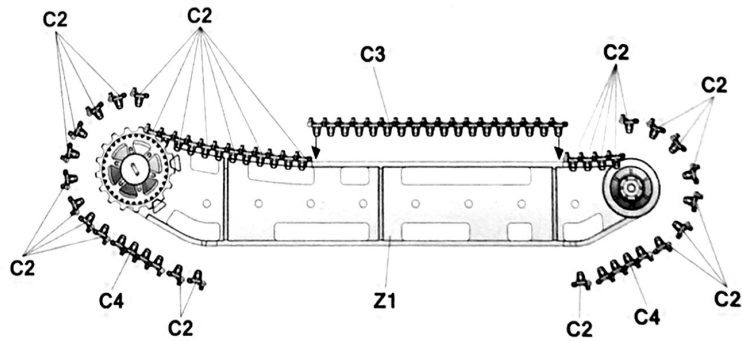

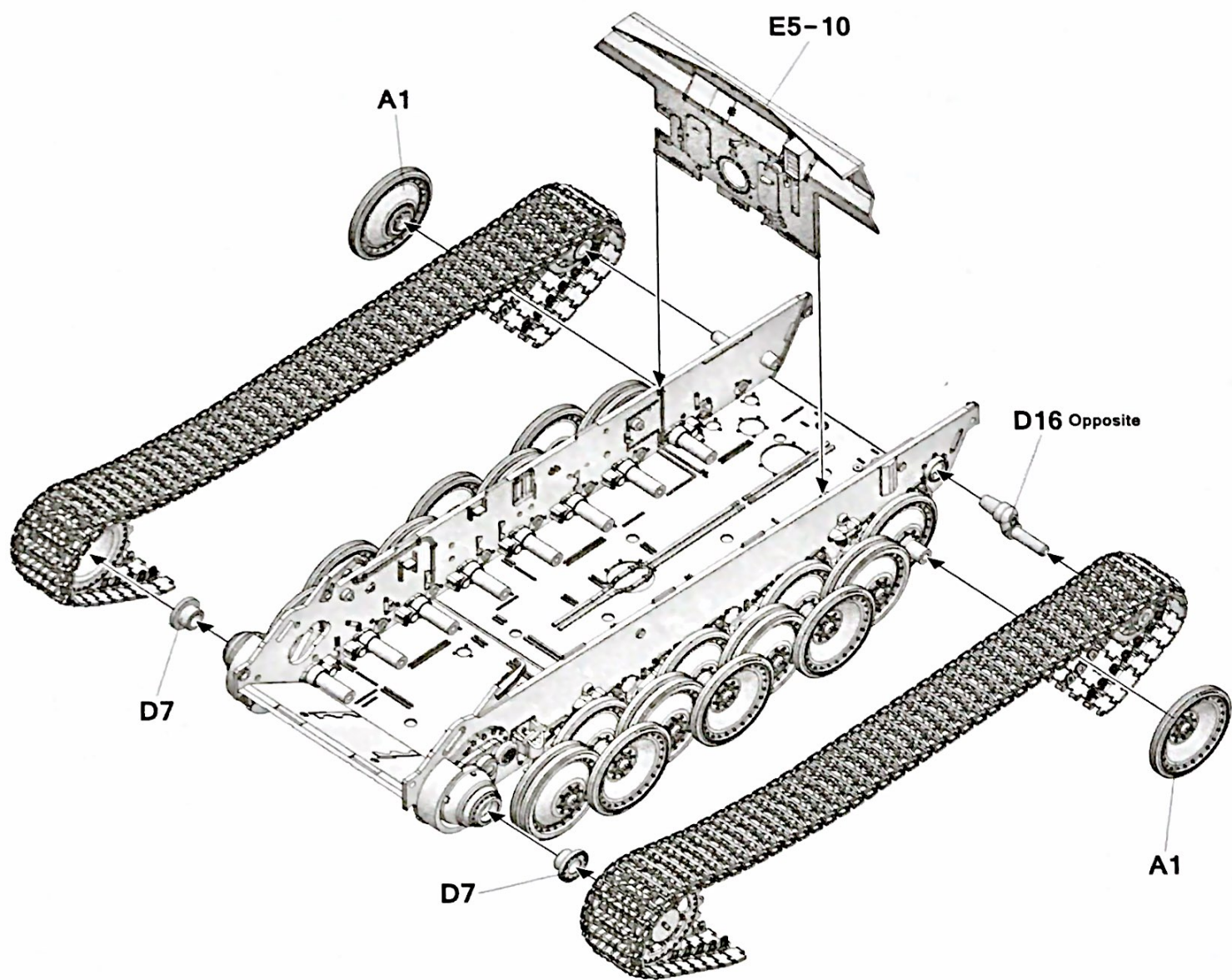
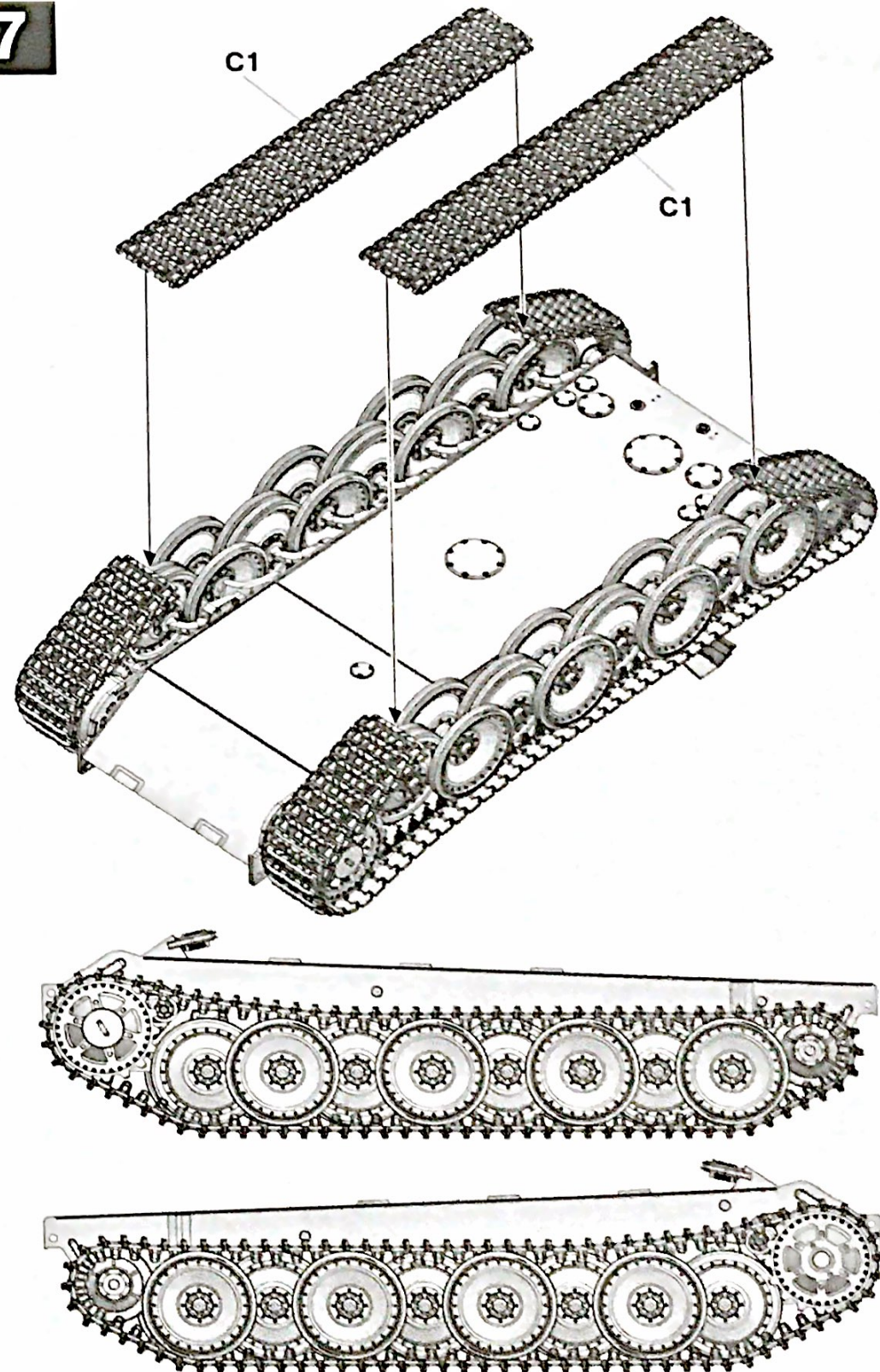
6**7**

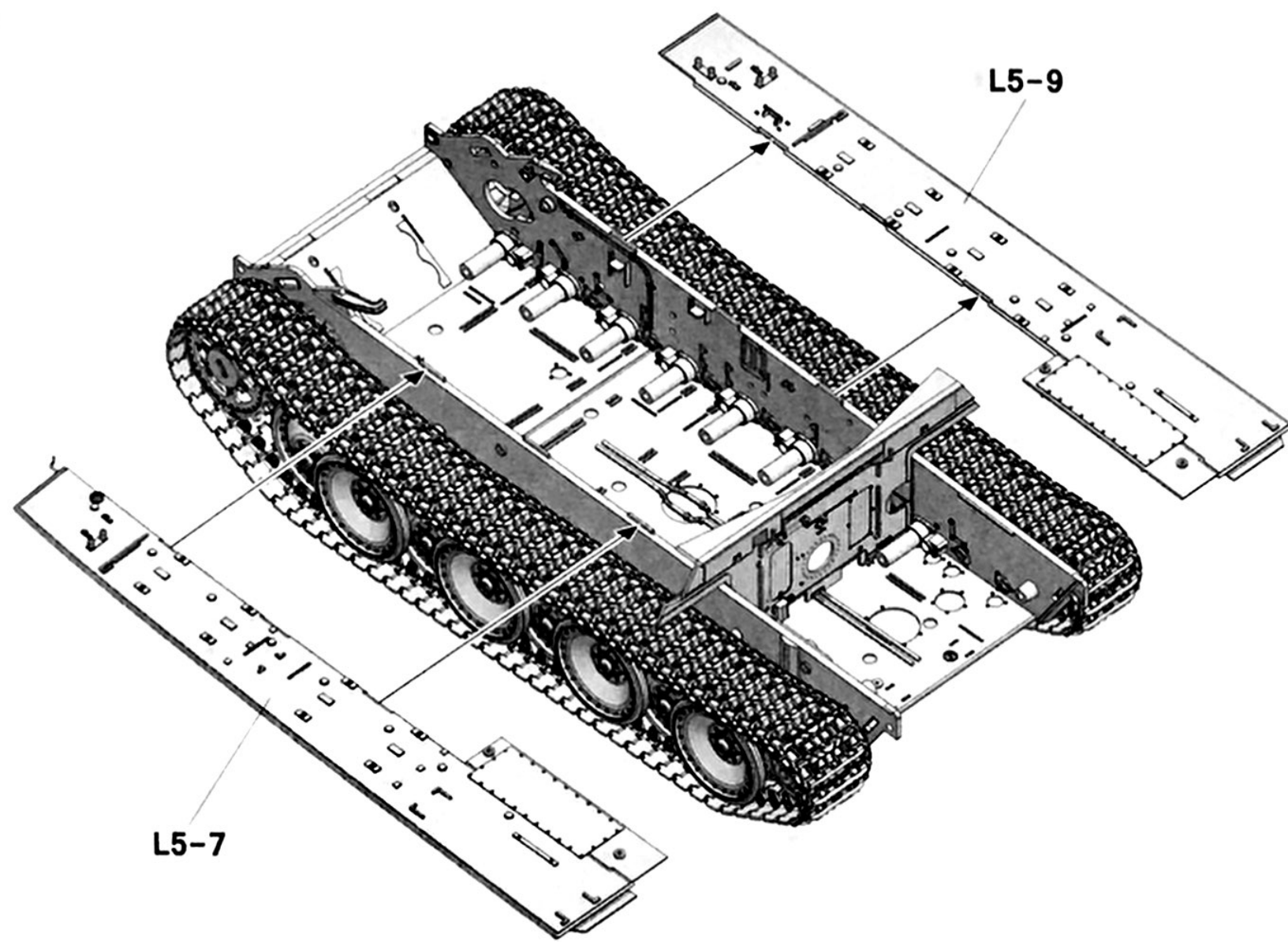
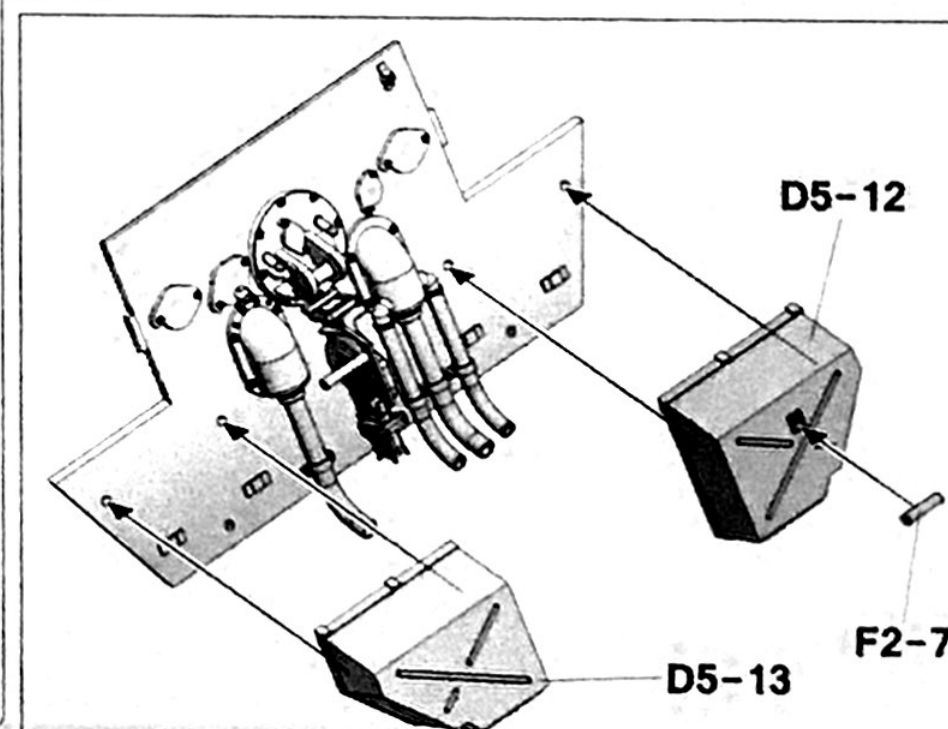
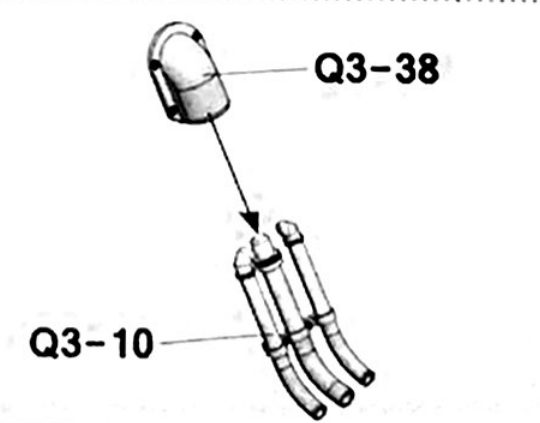
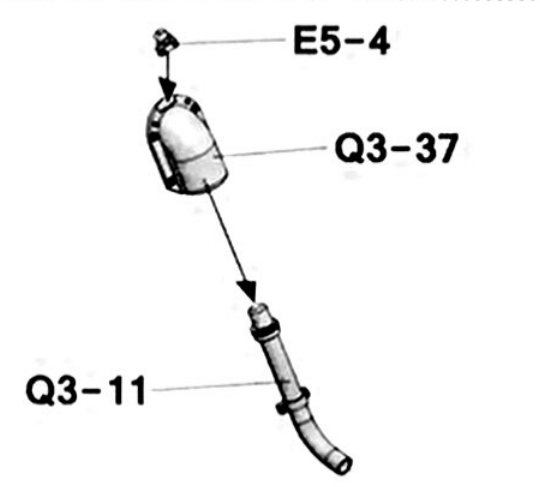
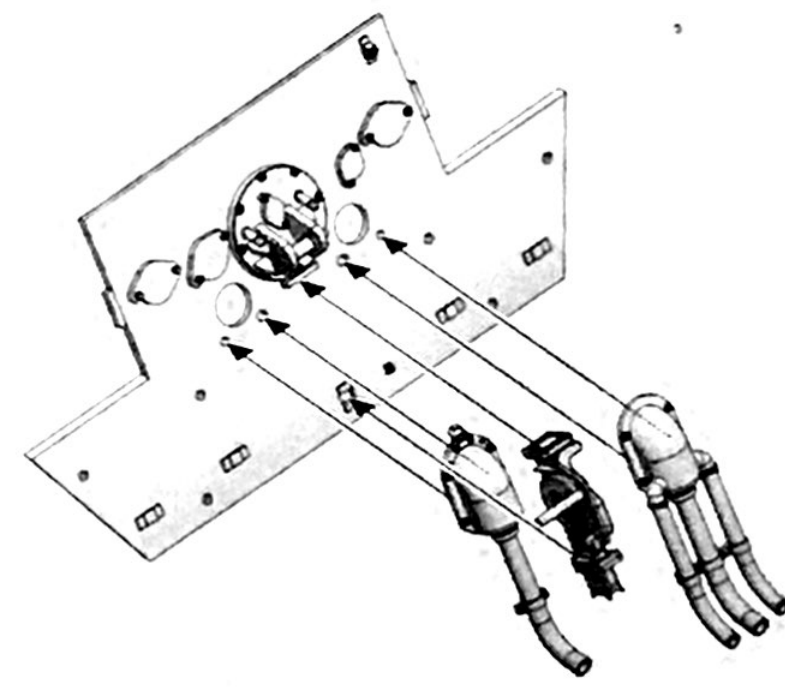
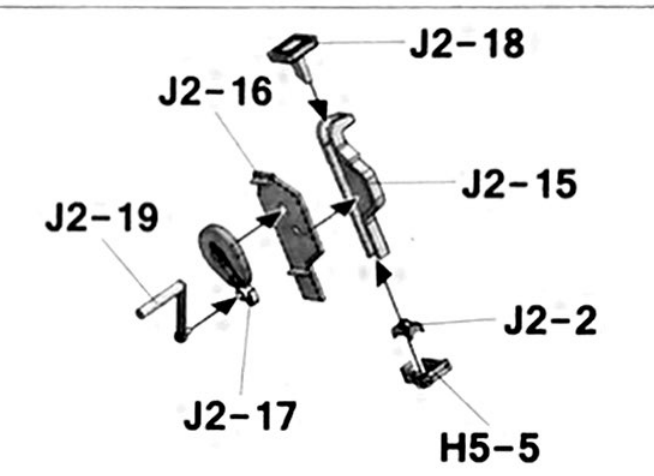
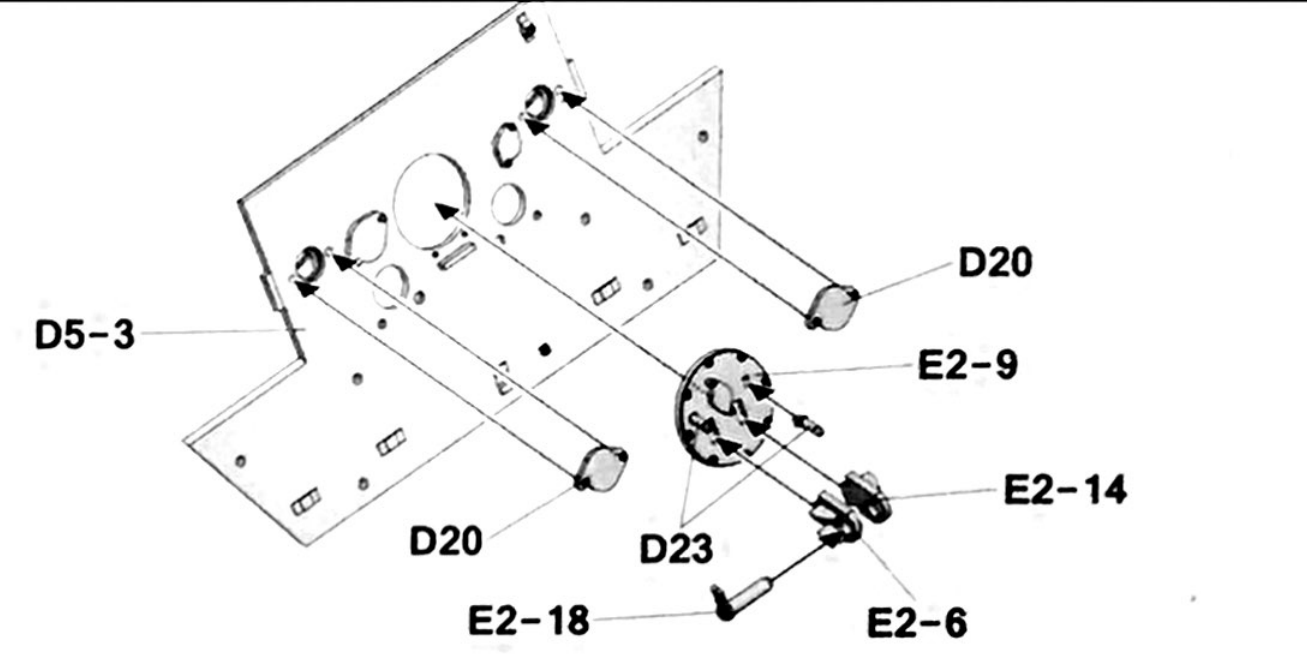
8**9**

10

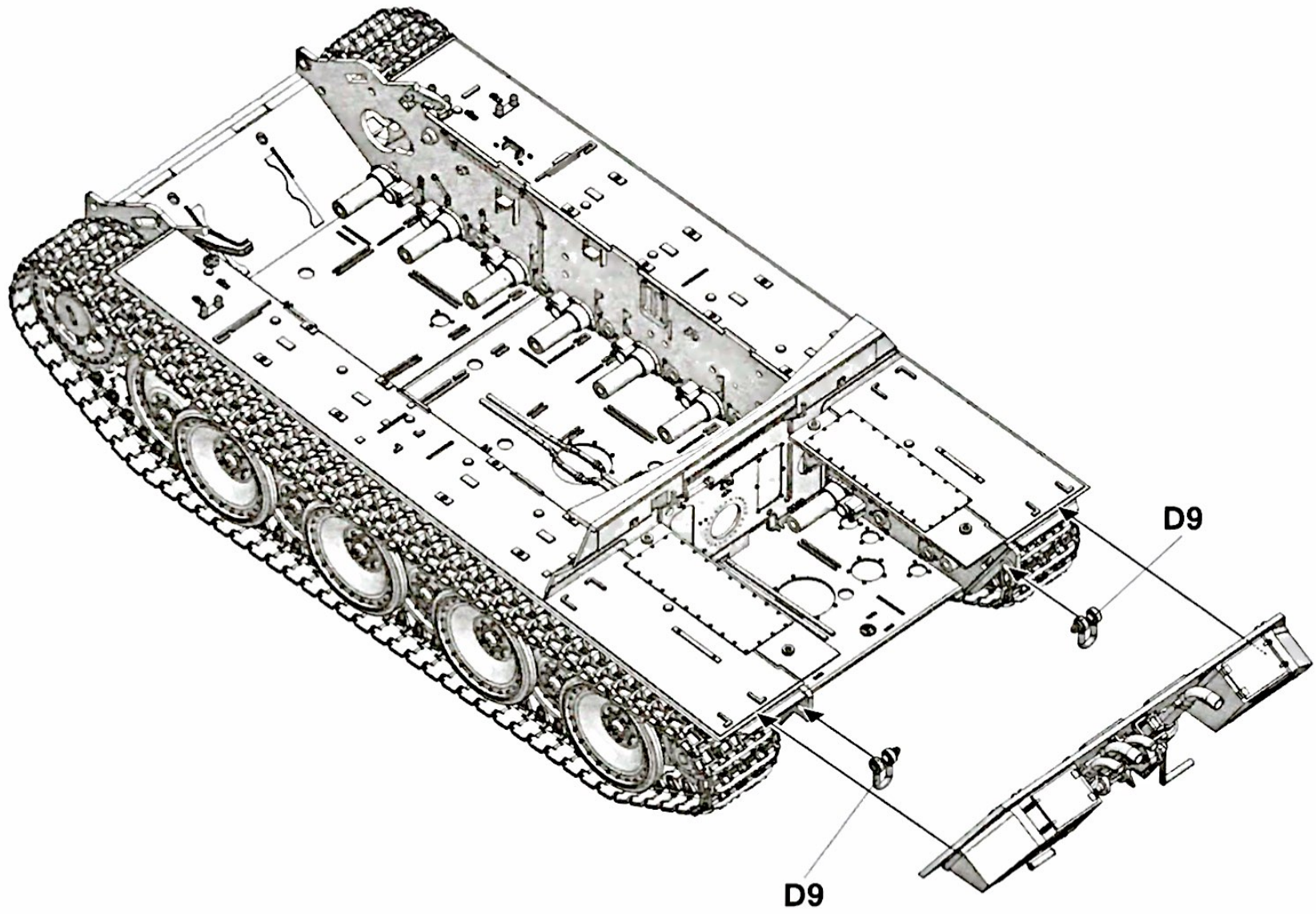

11

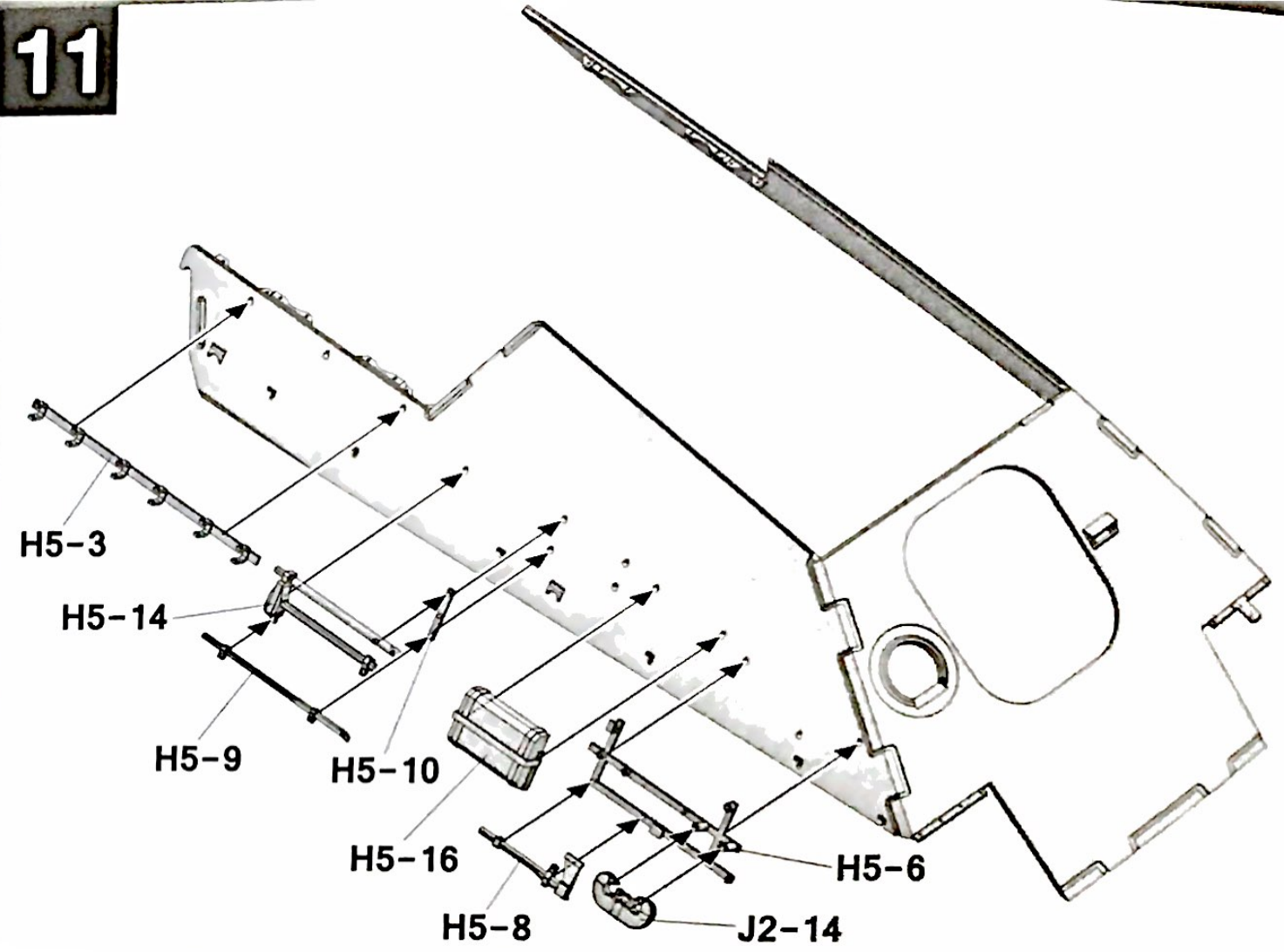

12

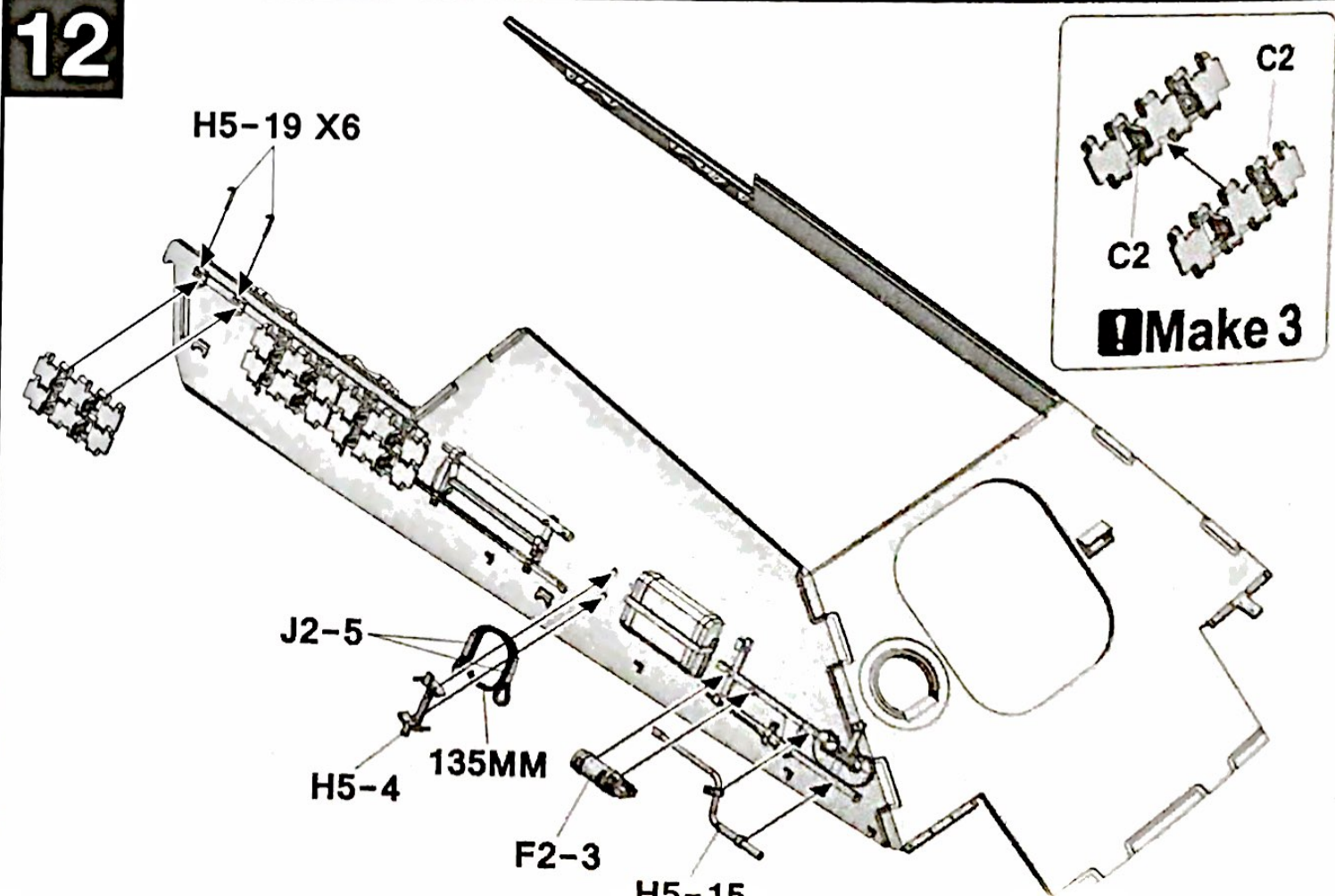

13

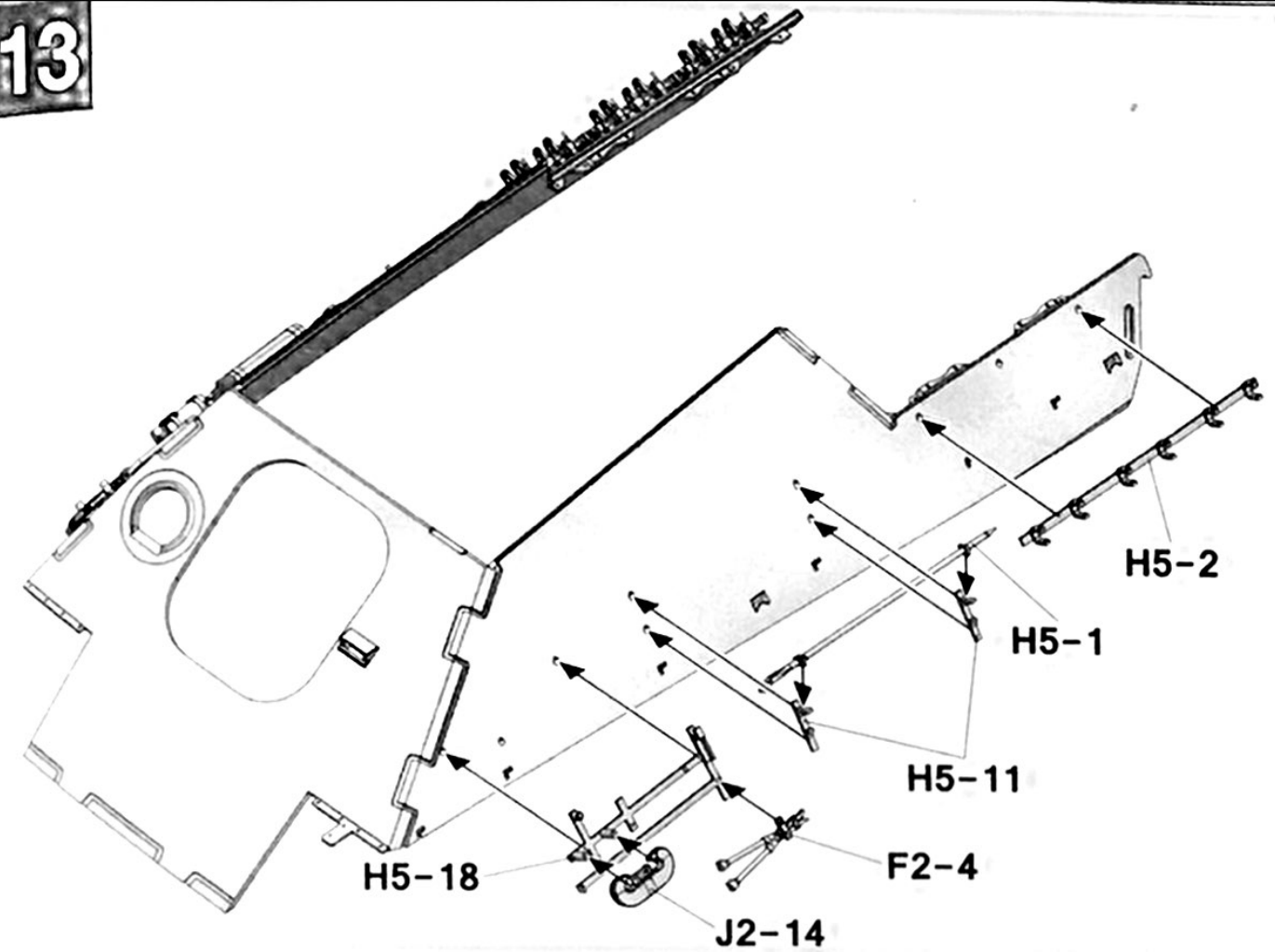

14

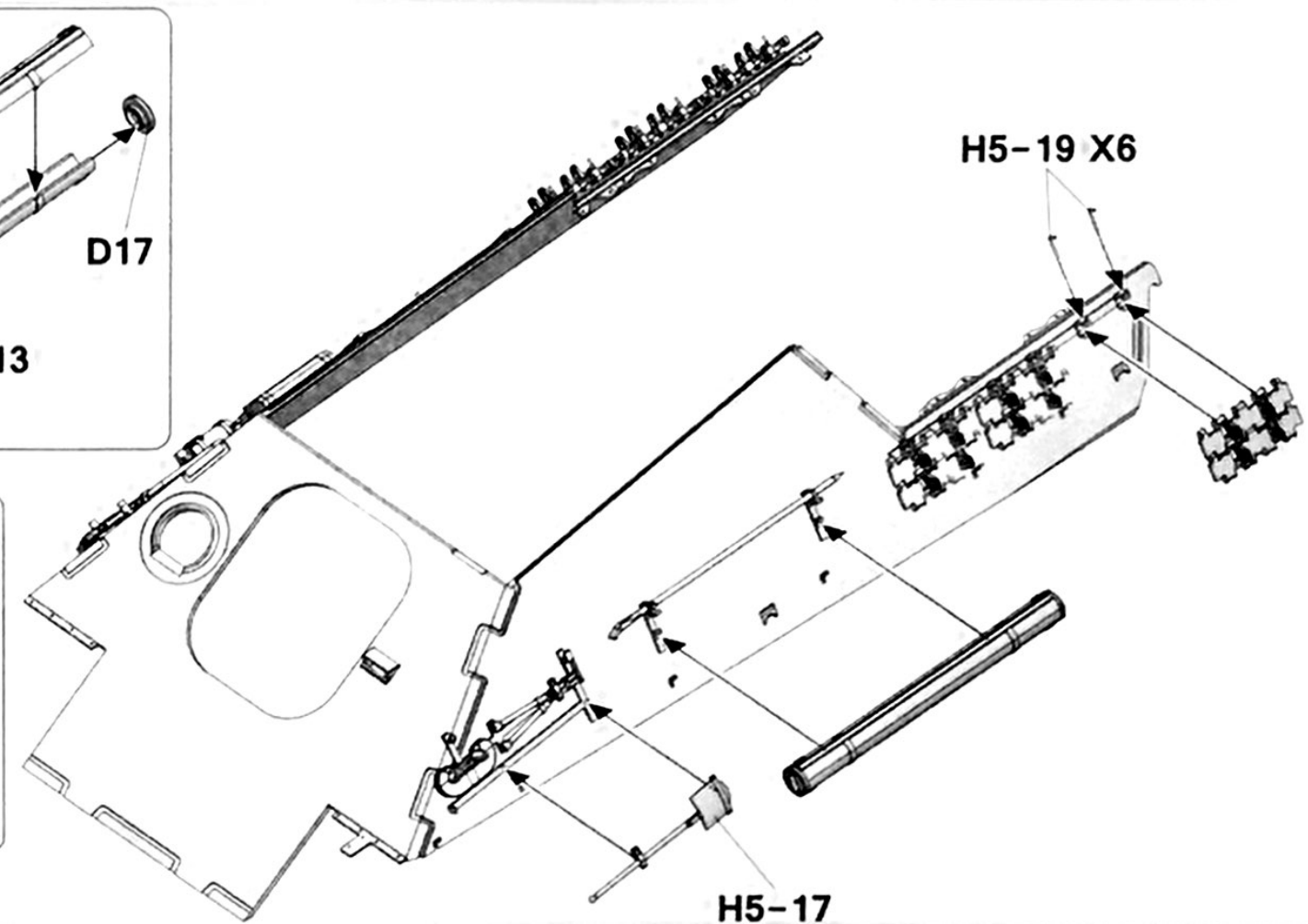
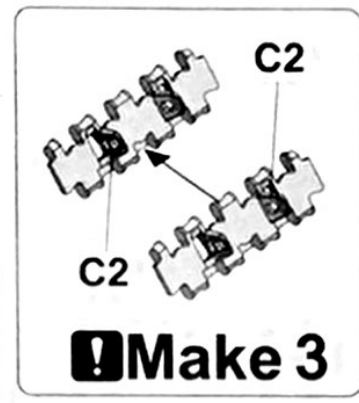
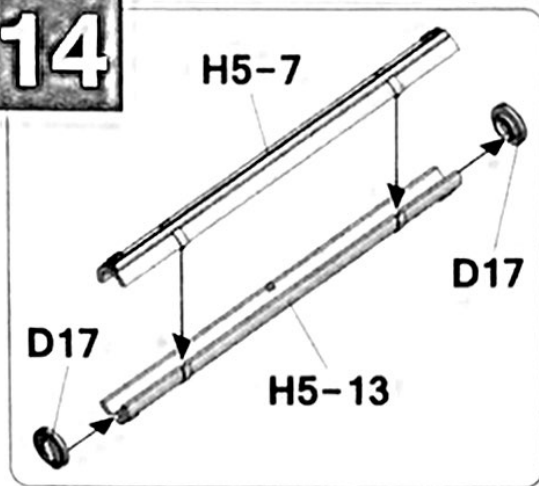

15

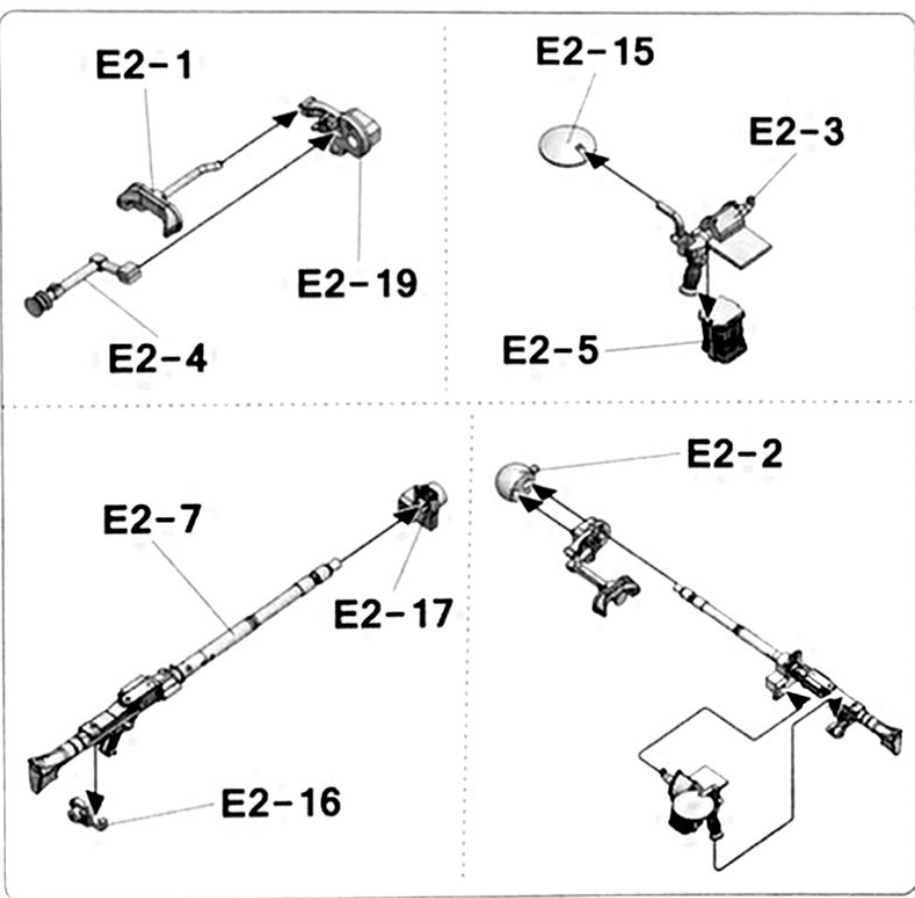
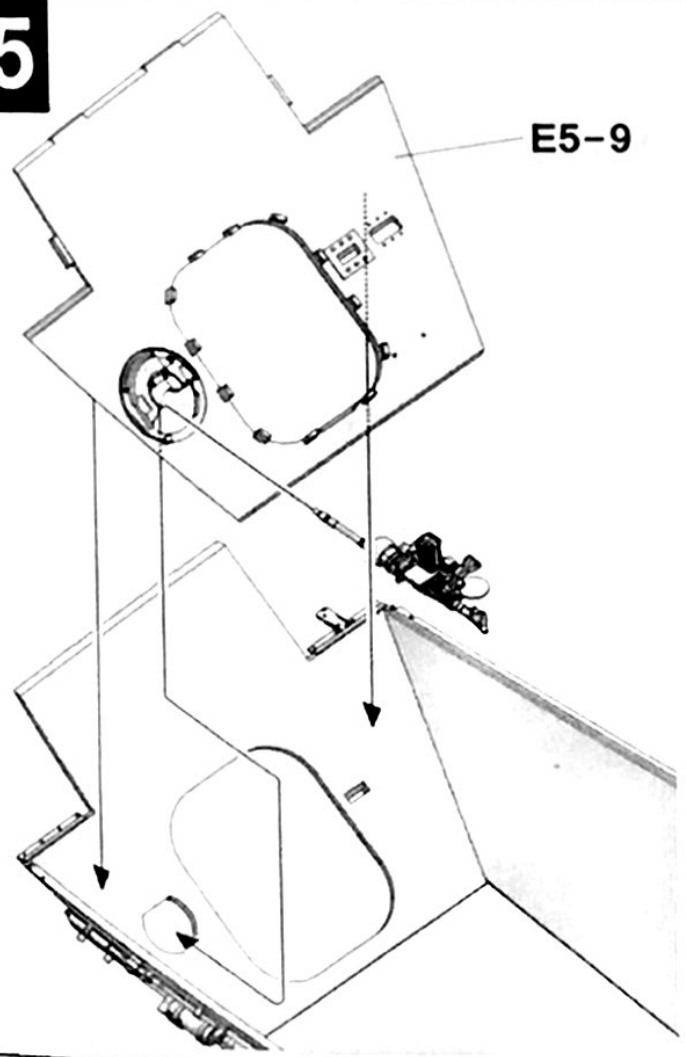

16

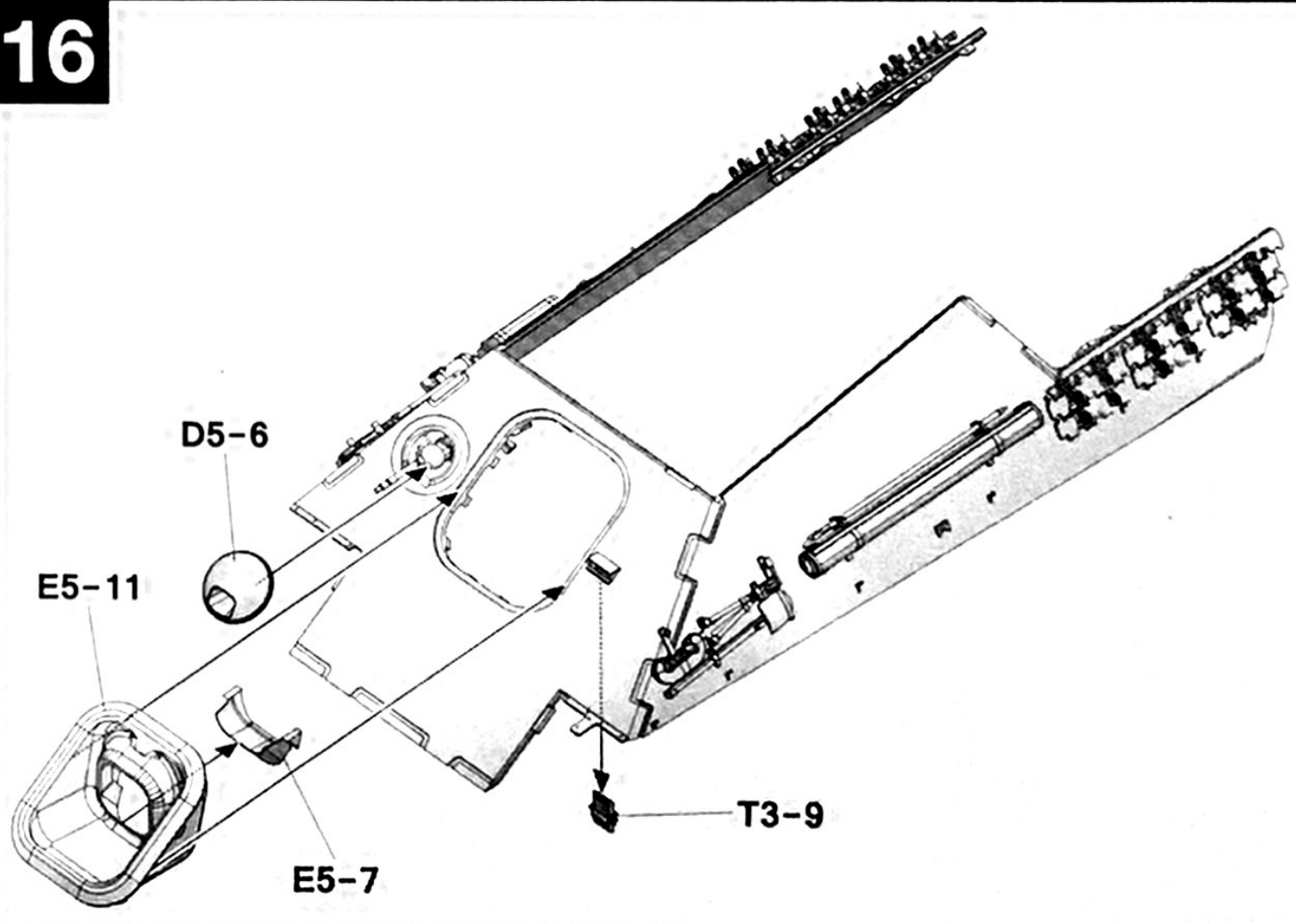

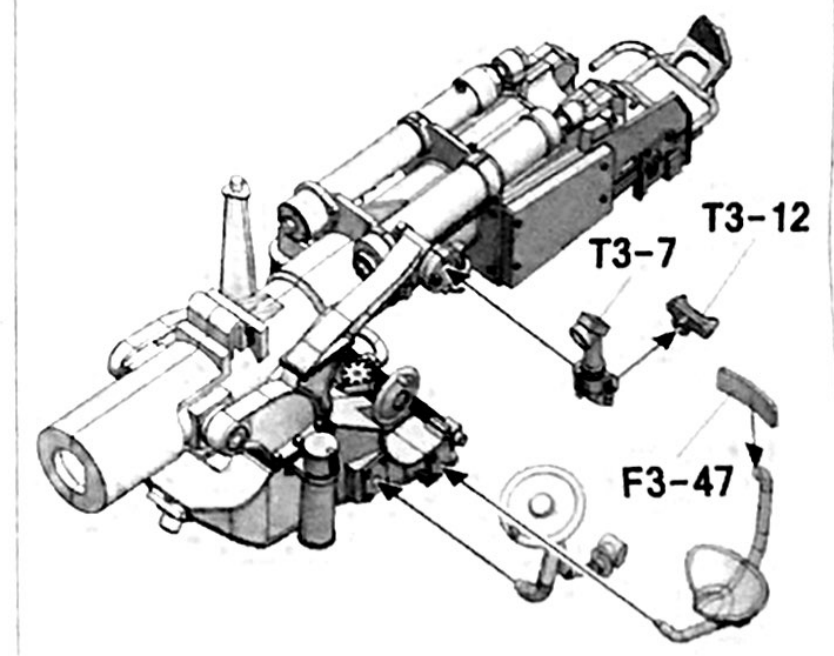
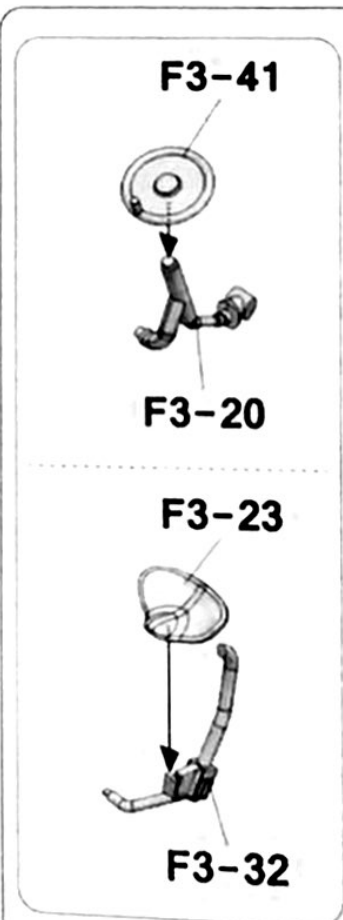
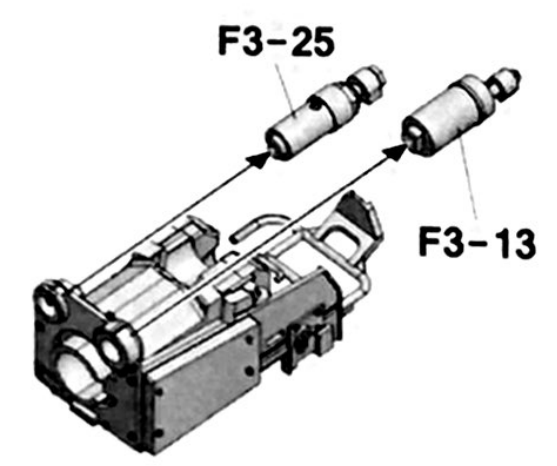
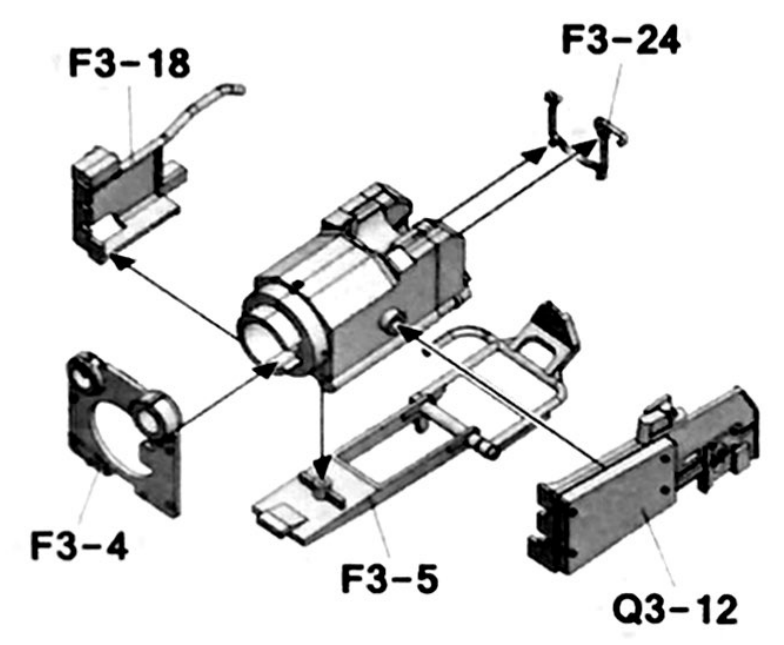
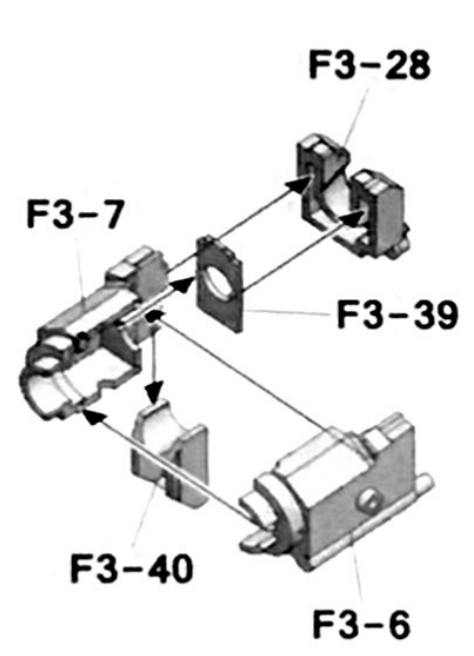
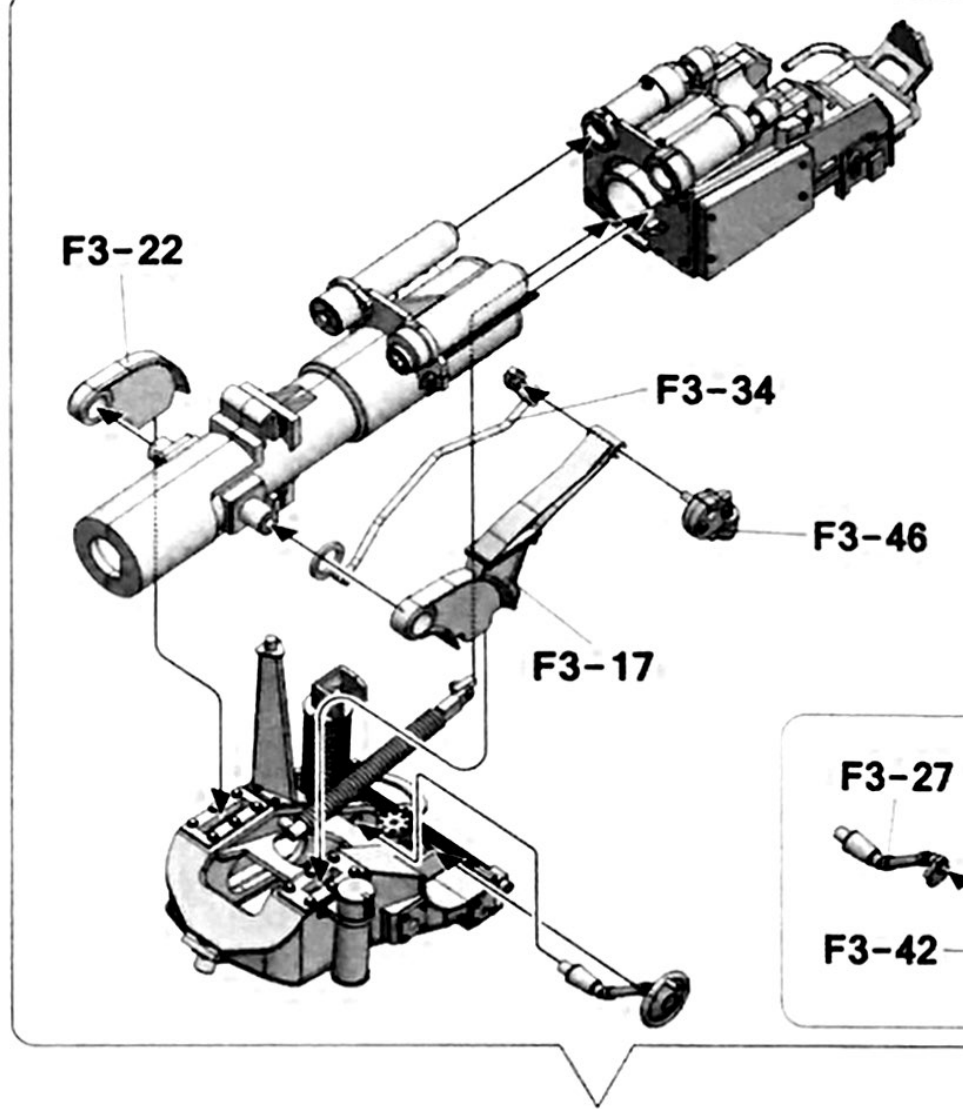
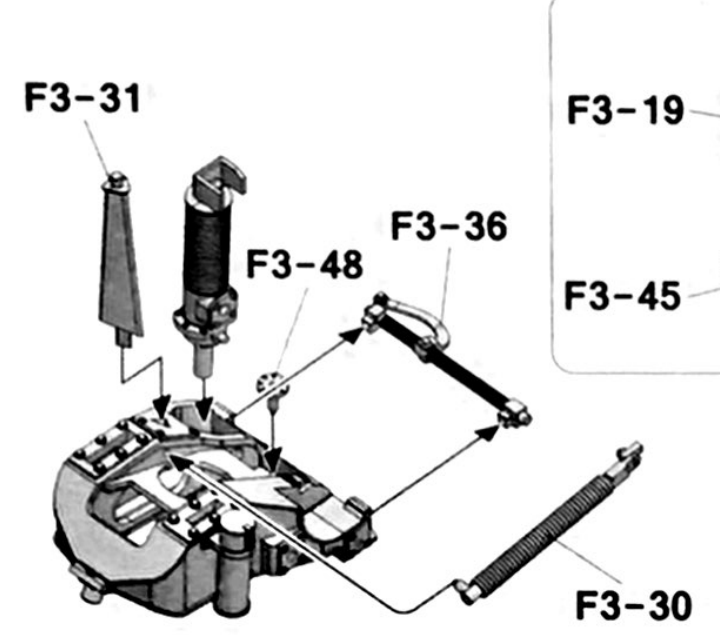
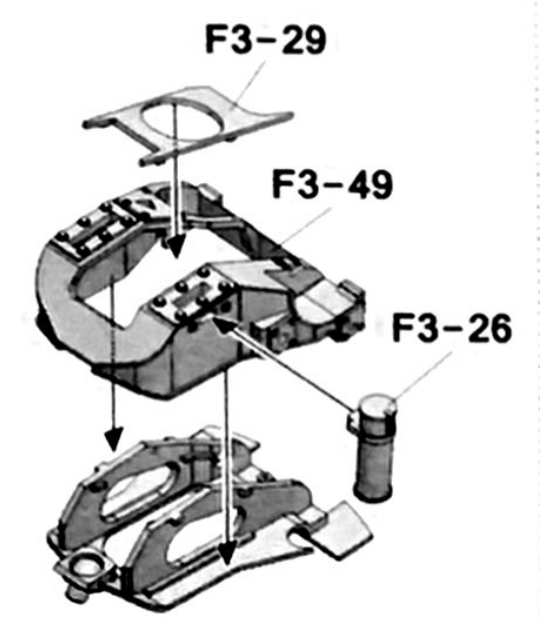
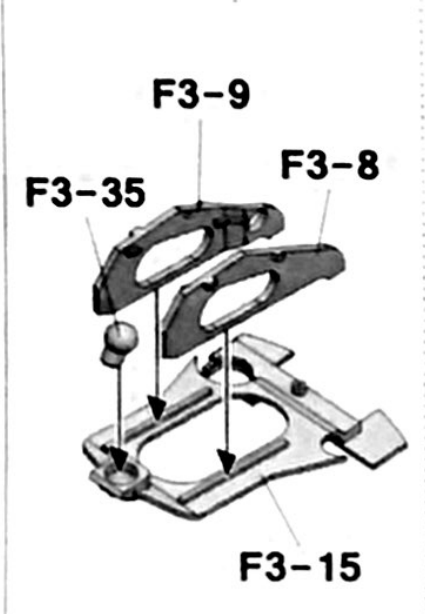
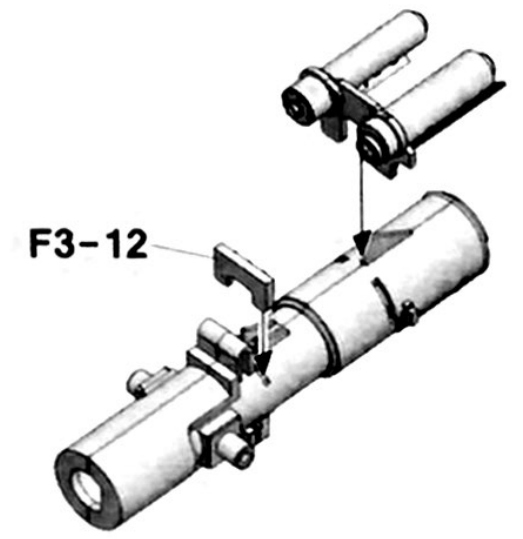
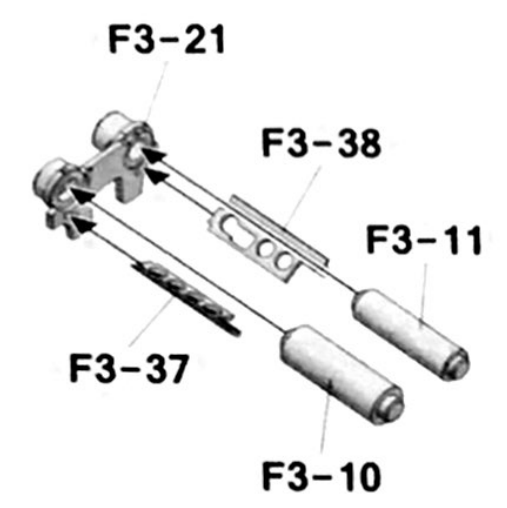
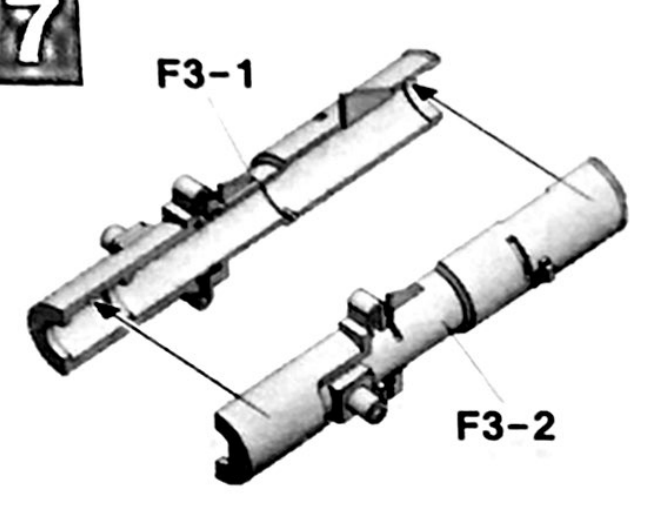

18

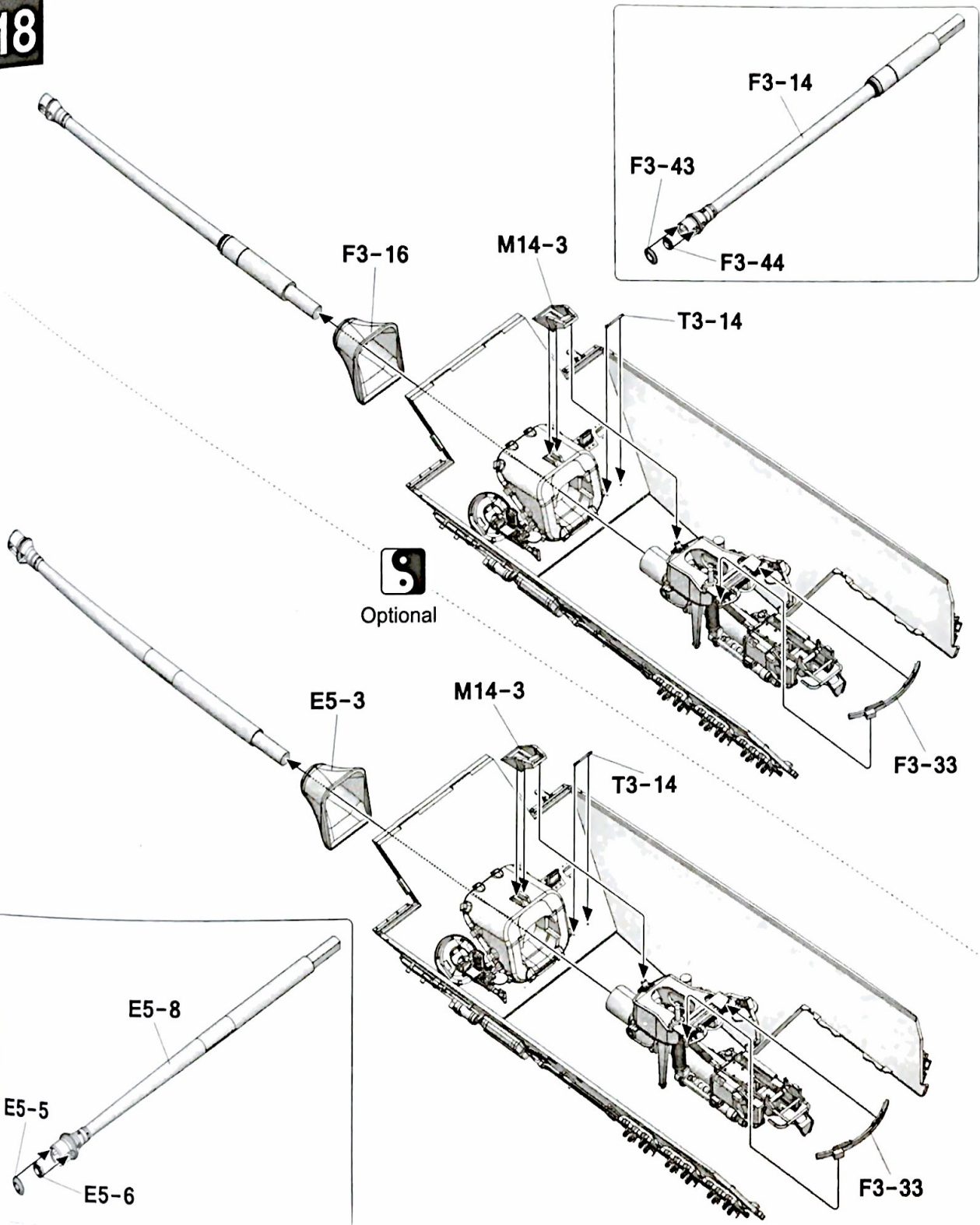

19

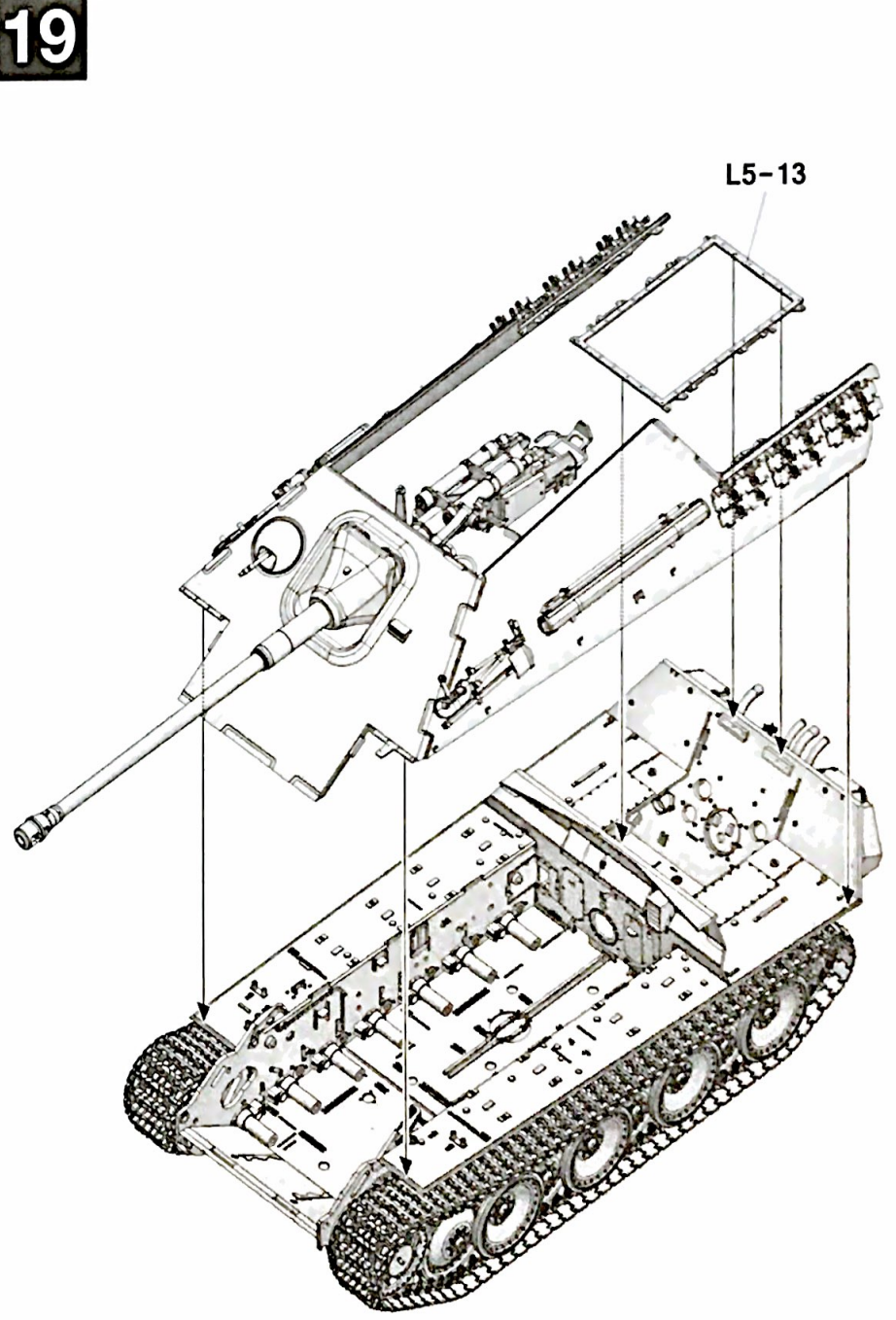

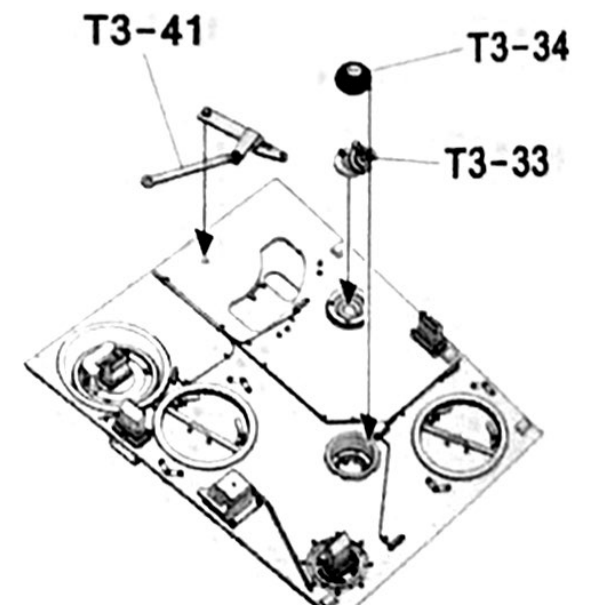
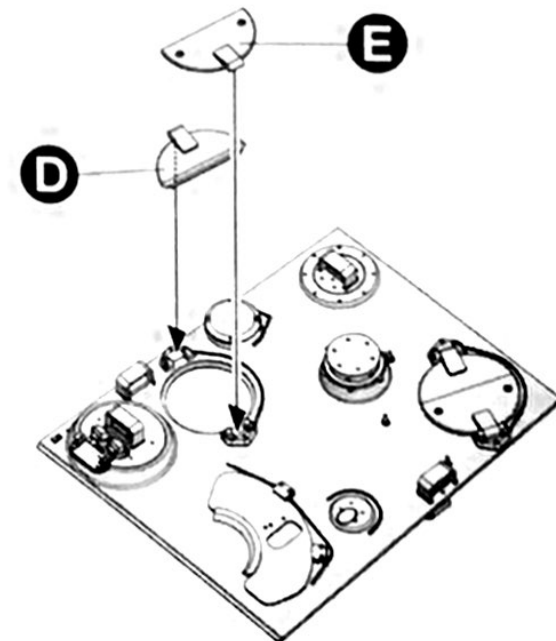
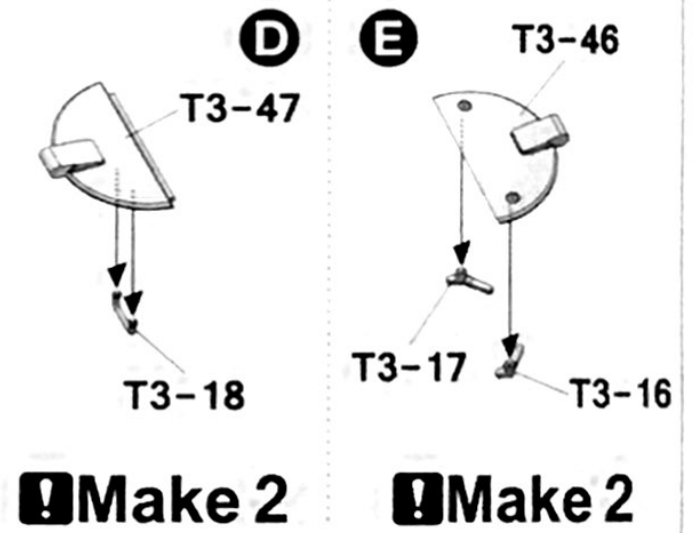
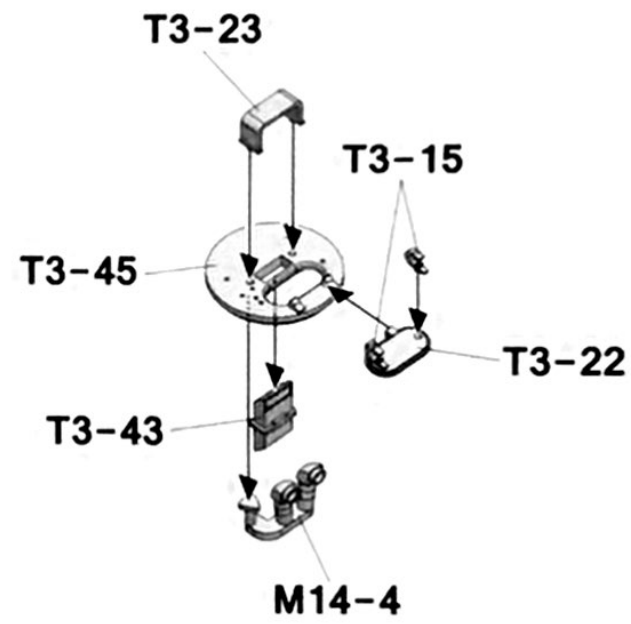
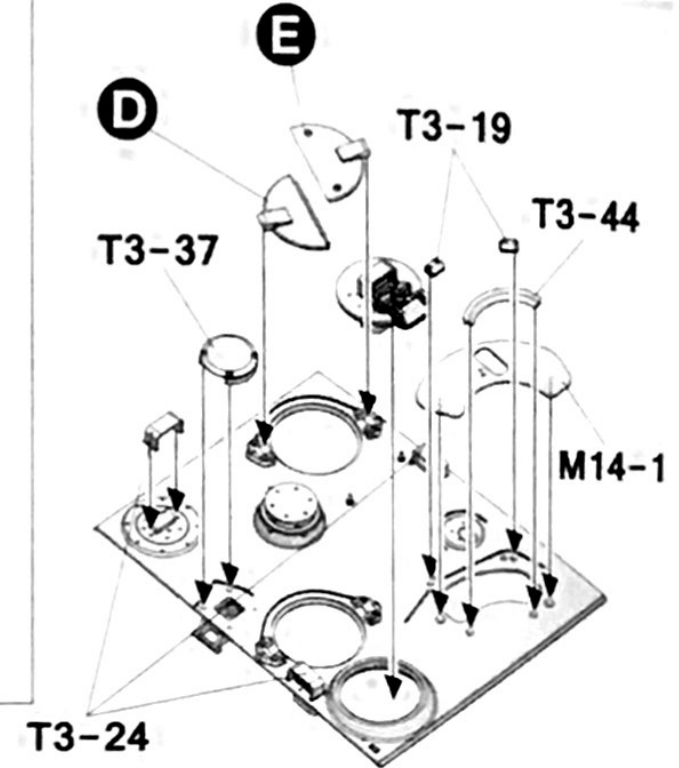
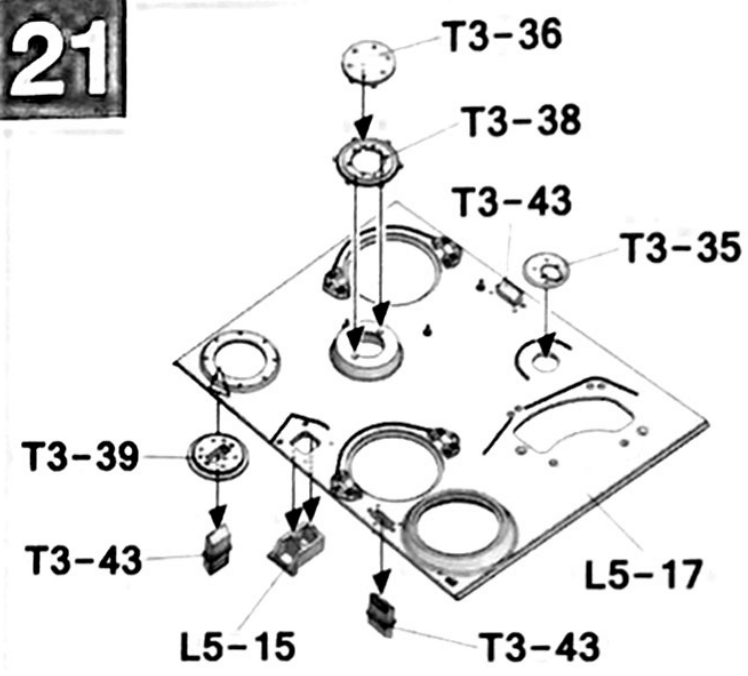
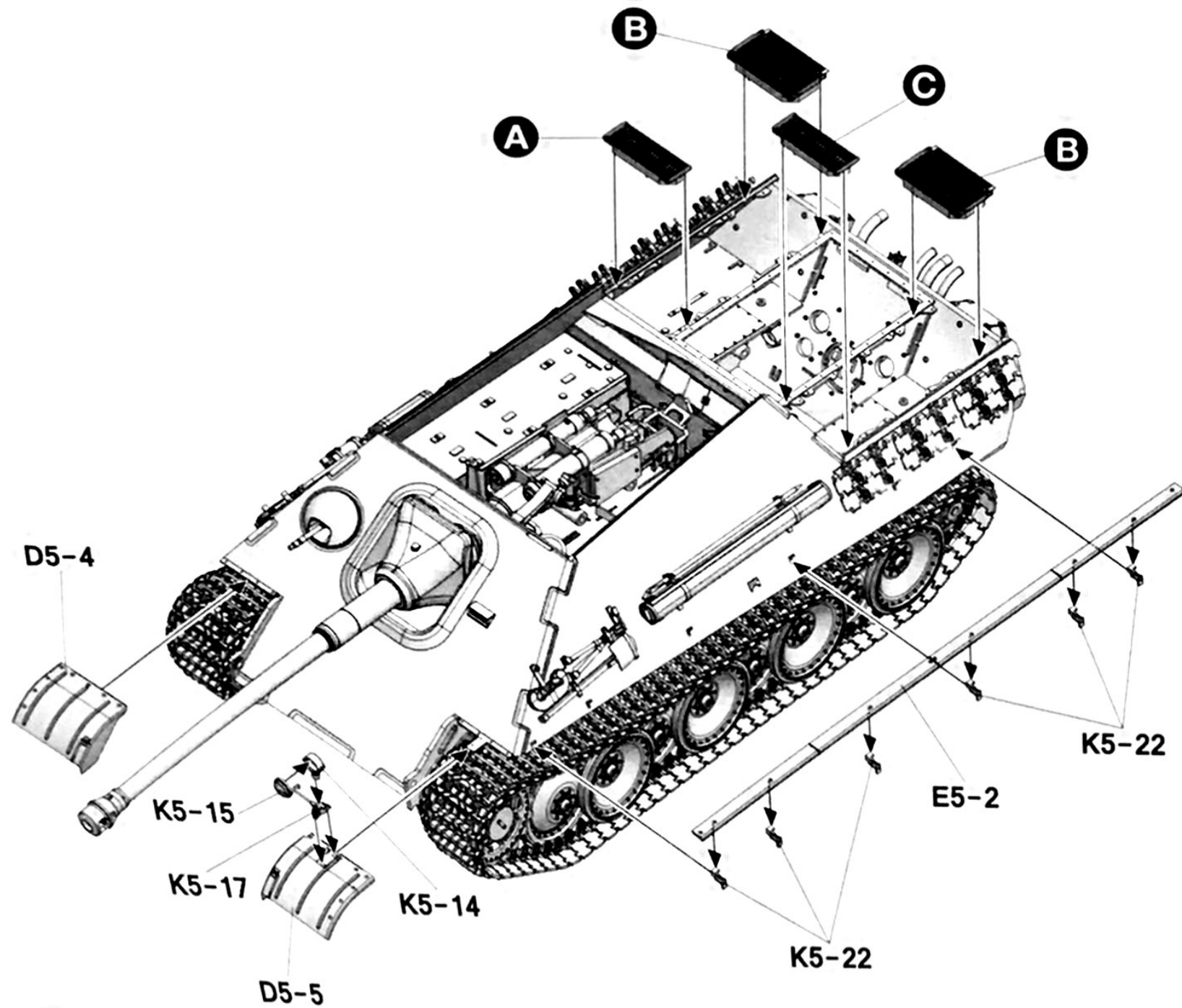
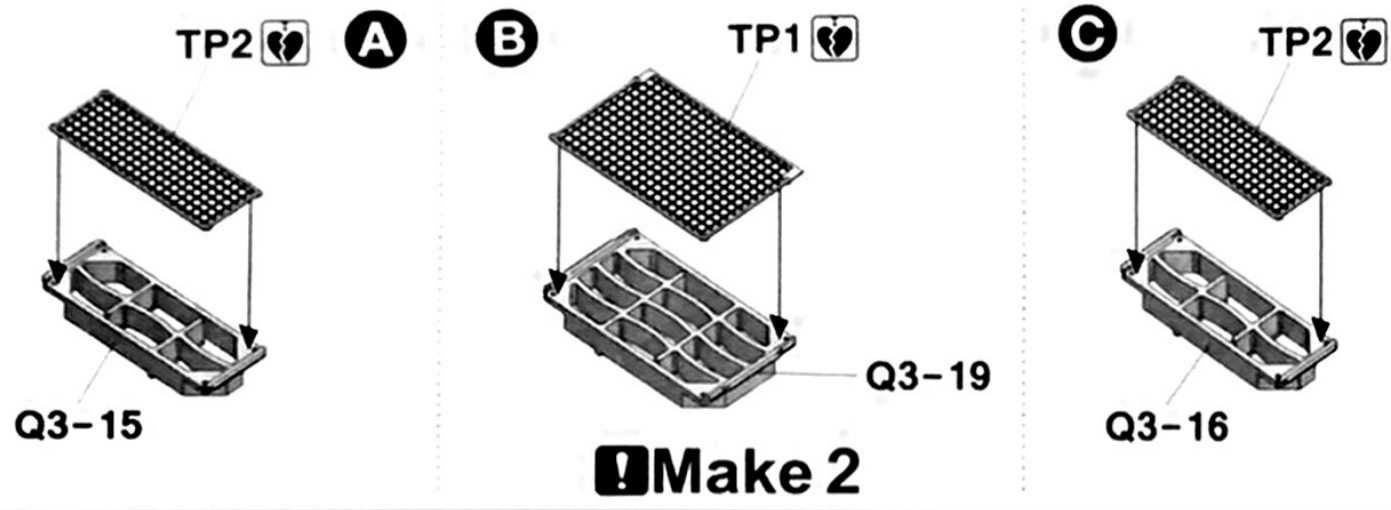

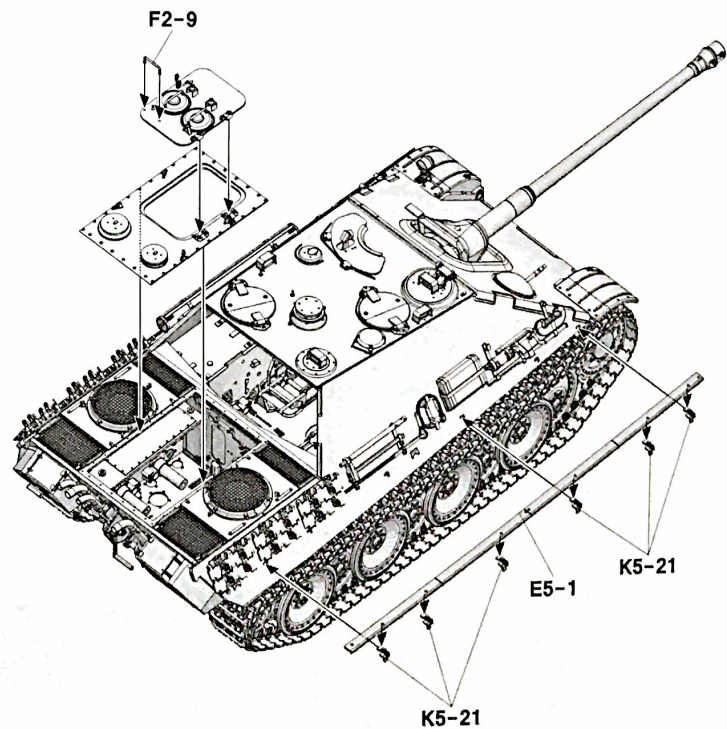
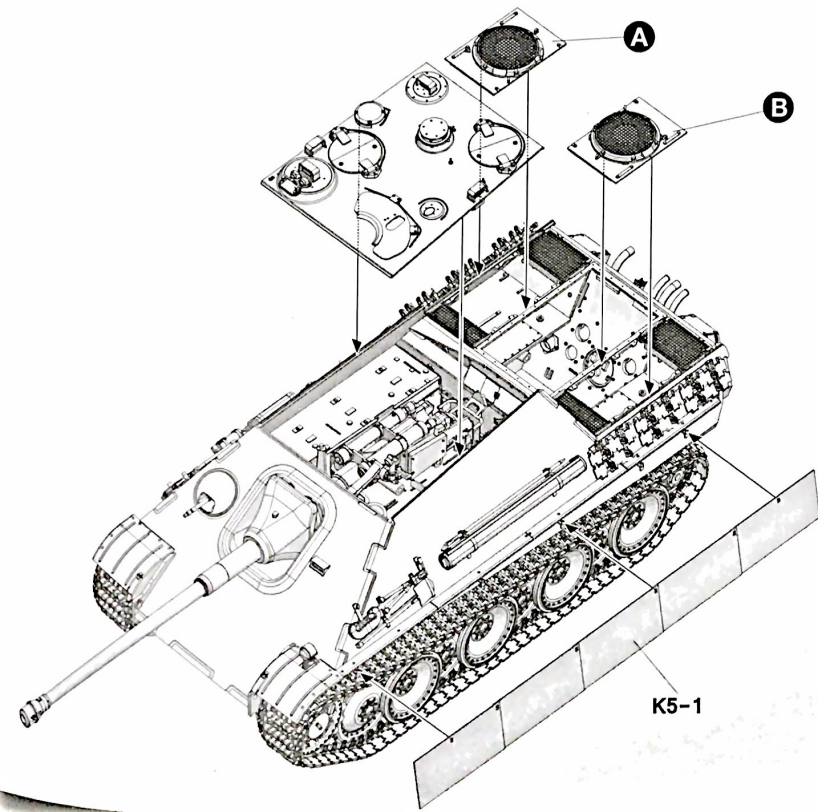
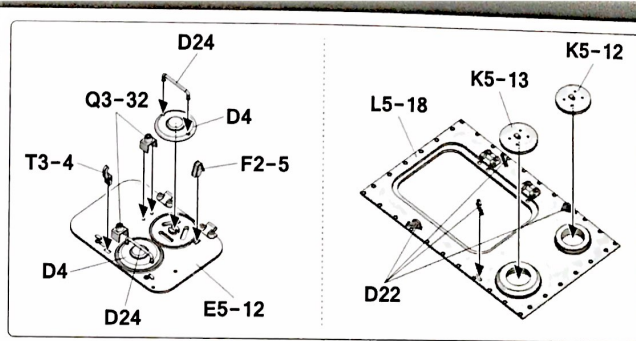
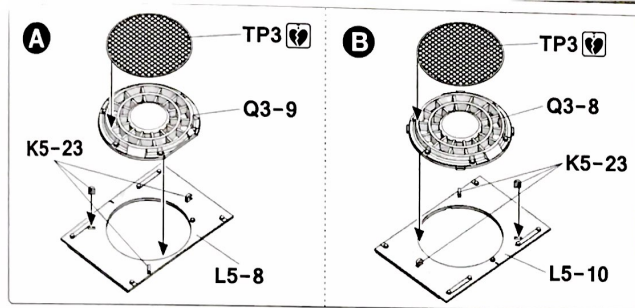

24

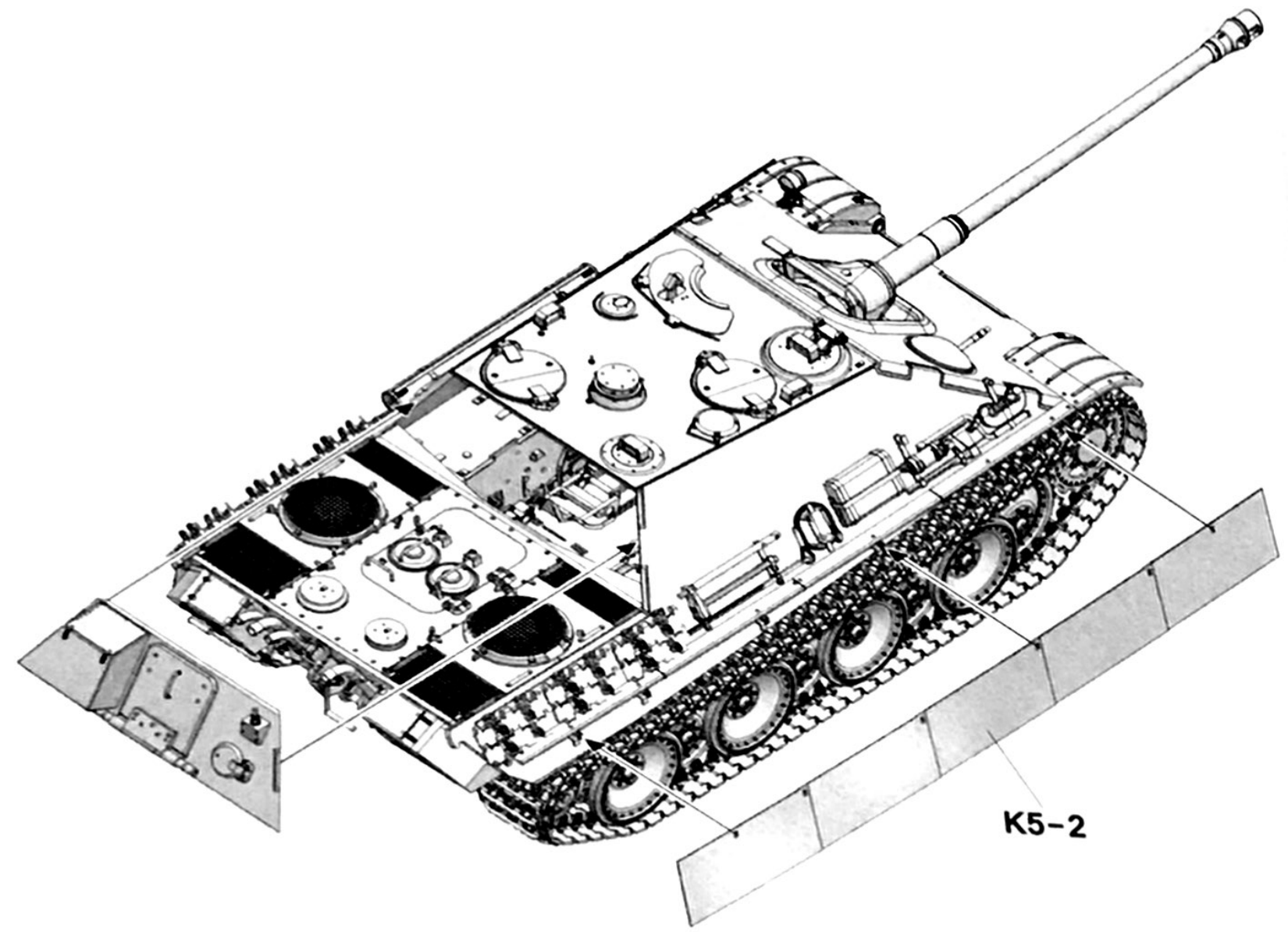
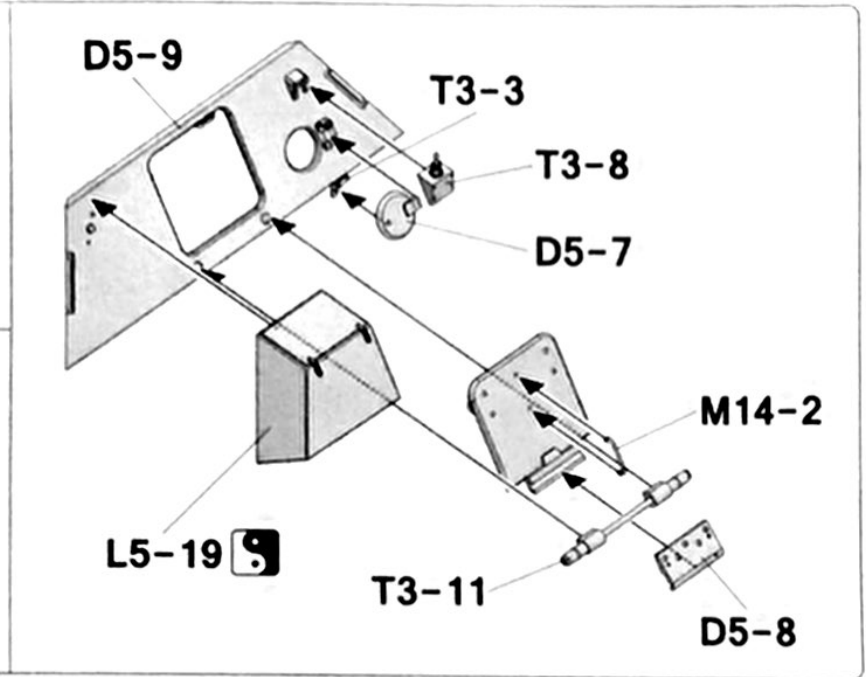
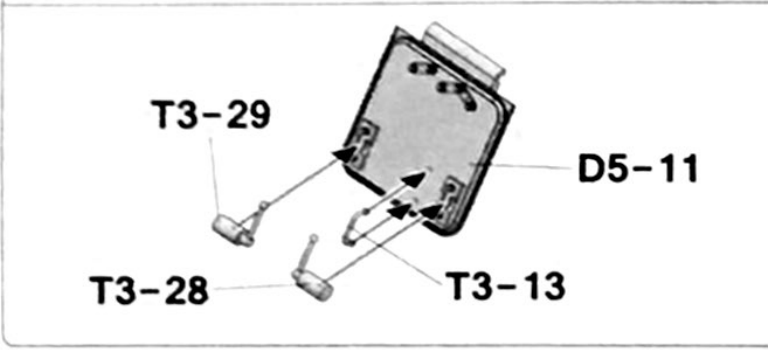
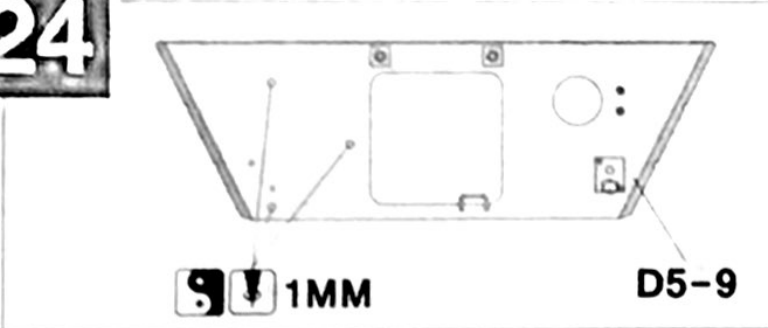

25

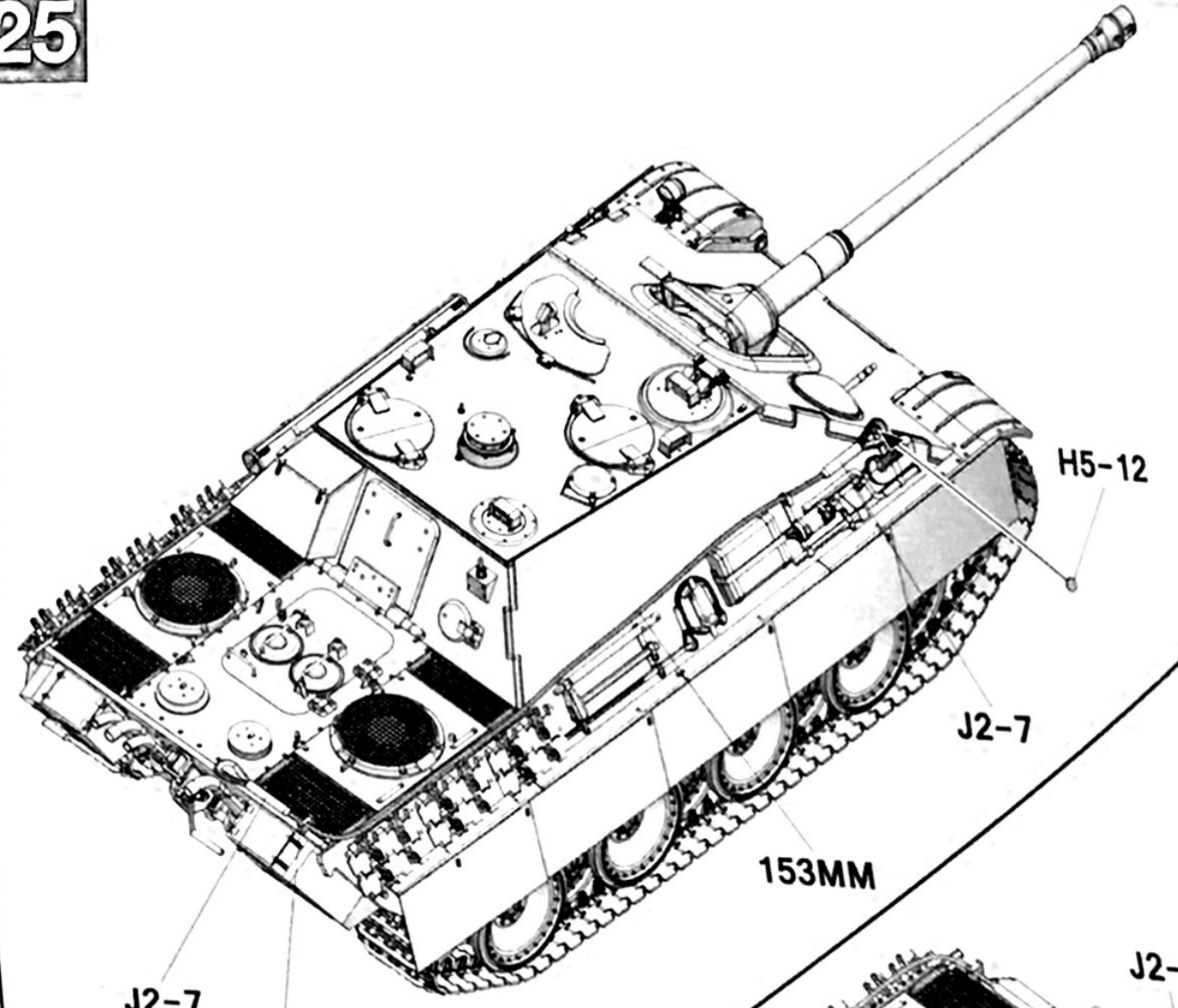

26

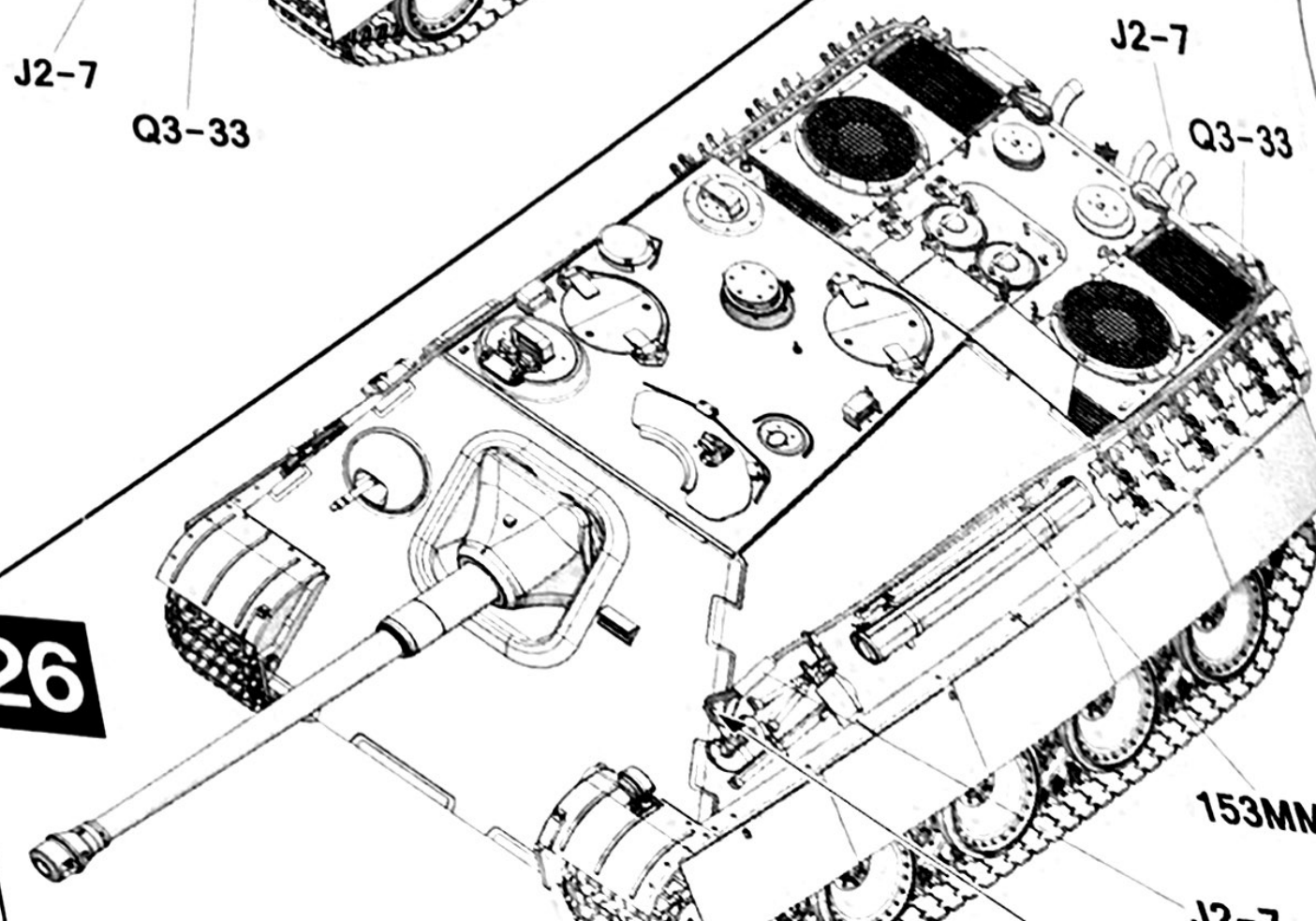

03.03.2125



Jagdpanther Ausf.G1

www.migimenez.com



Painting and Marking Guide

TAKOM Ref: 2125

Jagdpanther Ausf.G1 Mid/Late Production

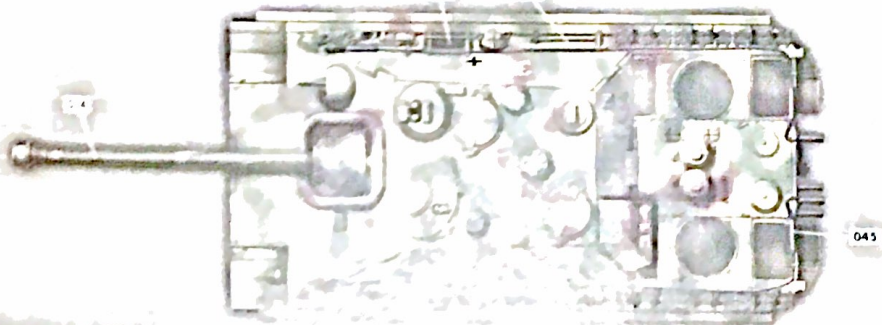
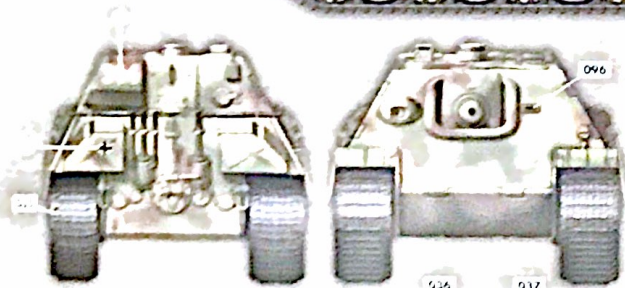
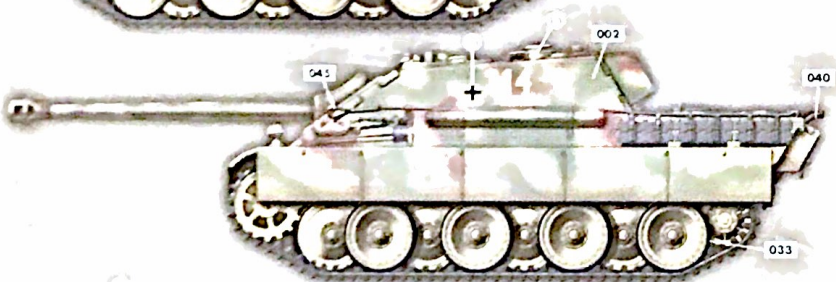
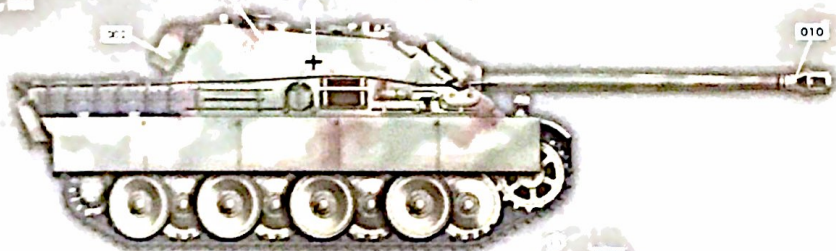
I Kompanie, s. Pz. Jg. Abt.559, Holland,
Summer 1944

GENERAL WASH

AMMO 1000 Gun Wash

STREAKING

AMMO 1203 Streaking Gun

FILTER

AMMO 1510 Filter

WASH & SPLASHES

AMMO 1705 Wash & Splashes

WASH & OIL

AMMO 1754 Wash & Oil

WASH & SPLASHES

AMMO 1705 Wash & Splashes

WASH & OIL

AMMO 1754 Wash & Oil

03.03.2125



Jagdpanther Ausf.G1

www.migimenez.com



Painting and Marking Guide

TAKOM Ref: 2125

Jagdpanther Ausf.G1 Mid/Late Production

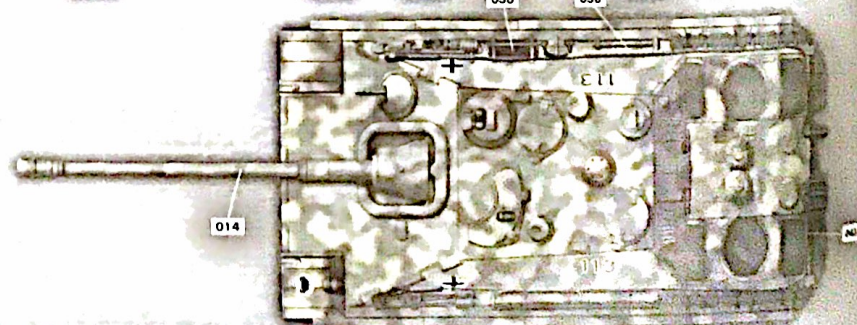
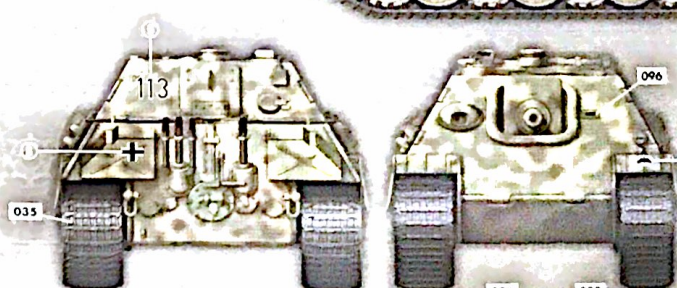
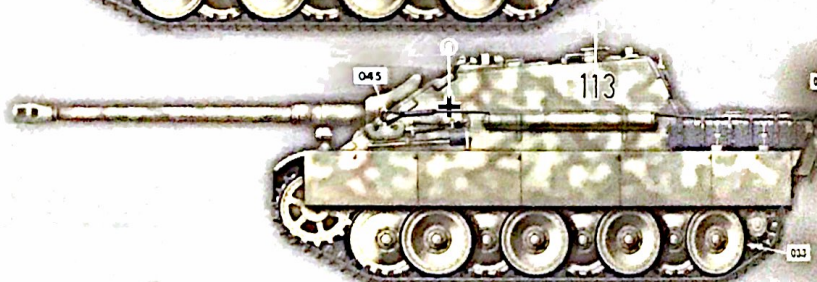
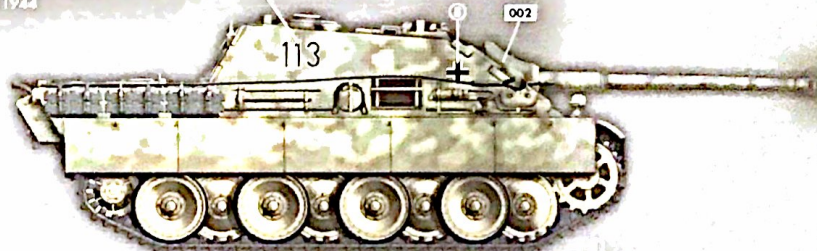
I Kompanie, s. Pz. Jg. Abt.559, Holland,
Summer 1944

GENERAL WASH

AMMO 1000 Gun Wash

STREAKING

AMMO 1203 Streaking Gun

FILTER

AMMO 1510 Filter

WASH & SPLASHES

AMMO 1705 Wash & Splashes

WASH & OIL

AMMO 1754 Wash & Oil

GENERAL WASH

AMMO 1000 Gun Wash

STREAKING

AMMO 1203 Streaking Gun

FILTER

AMMO 1510 Filter

WASH & SPLASHES

AMMO 1705 Wash & Splashes

WASH & OIL

AMMO 1754 Wash & Oil

Jagdpanther Ausf.G1

Painting and Marking Guide

TAKOM Ref: 2125
Jagdpanther Ausf.G1 Mid/Late Production

- A.MIG-033 Rubber & Tire
- A.MIG-035 Dark Irons
- A.MIG-036 Light Wood
- A.MIG-040 Medium Rust
- A.MIG-045 Dark Brown
- A.MIG-096 Crystal Polycarbonate Green
- A.MIG-002 Champagne Gold 3
- Darklight Yellow
- A.MIG-014 Dark Brown
- A.MIG-004 Dark Yellow

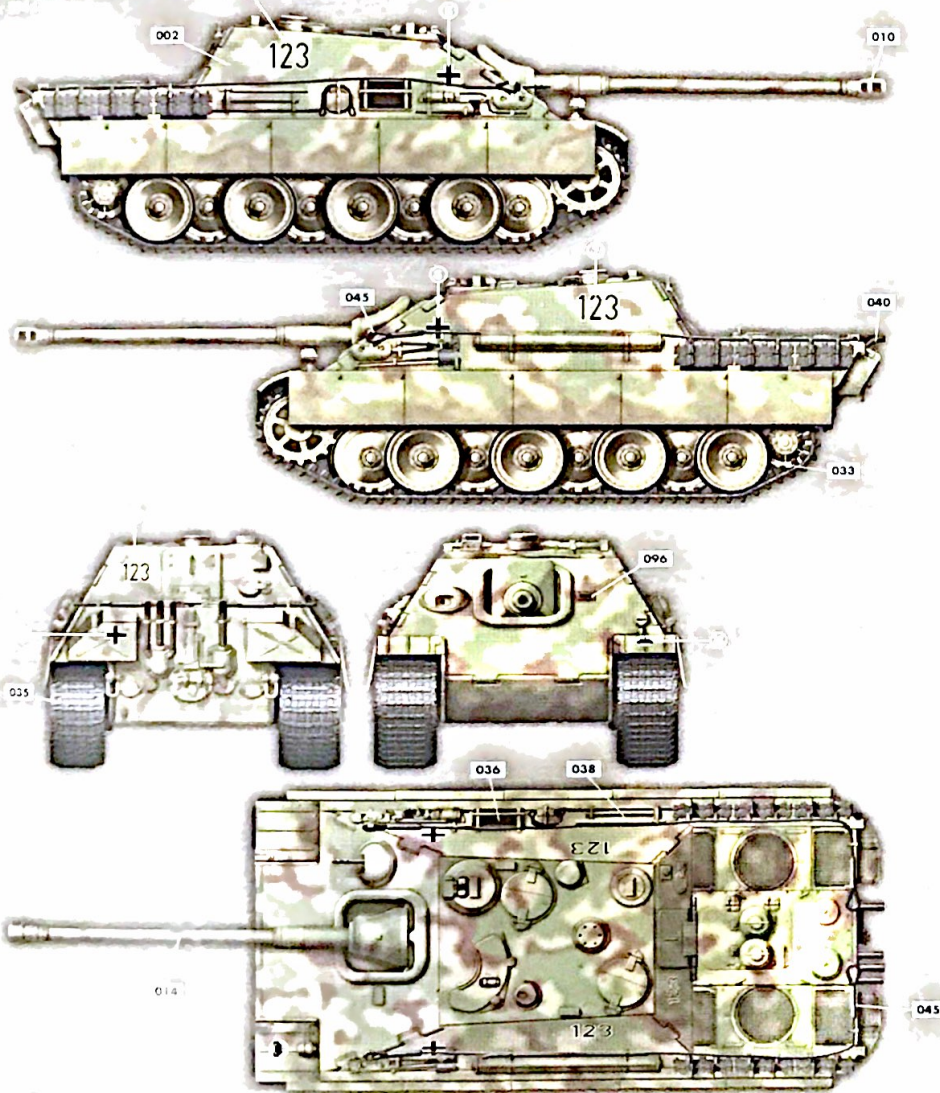

- 1 GENERAL WASH**
A.MIG-1000 Dark Brown Wash for Green
- 2 FILTER**
A.MIG-1010 Tan for 1 Tone Coat
- 3 STREAKING**
A.MIG-1253 Streaking/brusher Grime
- 4 WATER WASH**
A.MIG-1002 Tracks Wash
- 5 RUST**
A.MIG-3510 Rust
- 6 DUST**
A.MIG-3011 Arfield Dust
- 7 MUD & SPLASHES**
A.MIG-1704 Heavy Earth / A.MIG-1753 Tanned Oil
- 8 GREASE & OIL**
A.MIG-1408 Fresh Engine Oil

Jagdpanther Ausf.G1

Painting and Marking Guide

TAKOM Ref: 2125
Jagdpanther Ausf.G1 Mid/Late Production

- A.MIG-033 Rubber & Tire
- A.MIG-035 Dark Irons
- A.MIG-036 Light Wood
- A.MIG-040 Medium Rust
- A.MIG-045 Dark Brown
- A.MIG-096 Crystal Polycarbonate Green
- Darklight Yellow
- A.MIG-002 Champagne Gold 3
- A.MIG-004 Dark Yellow
- A.MIG-006

1 Kompanie, s. Pz. Jg. Abt.654, France, Spring 1944

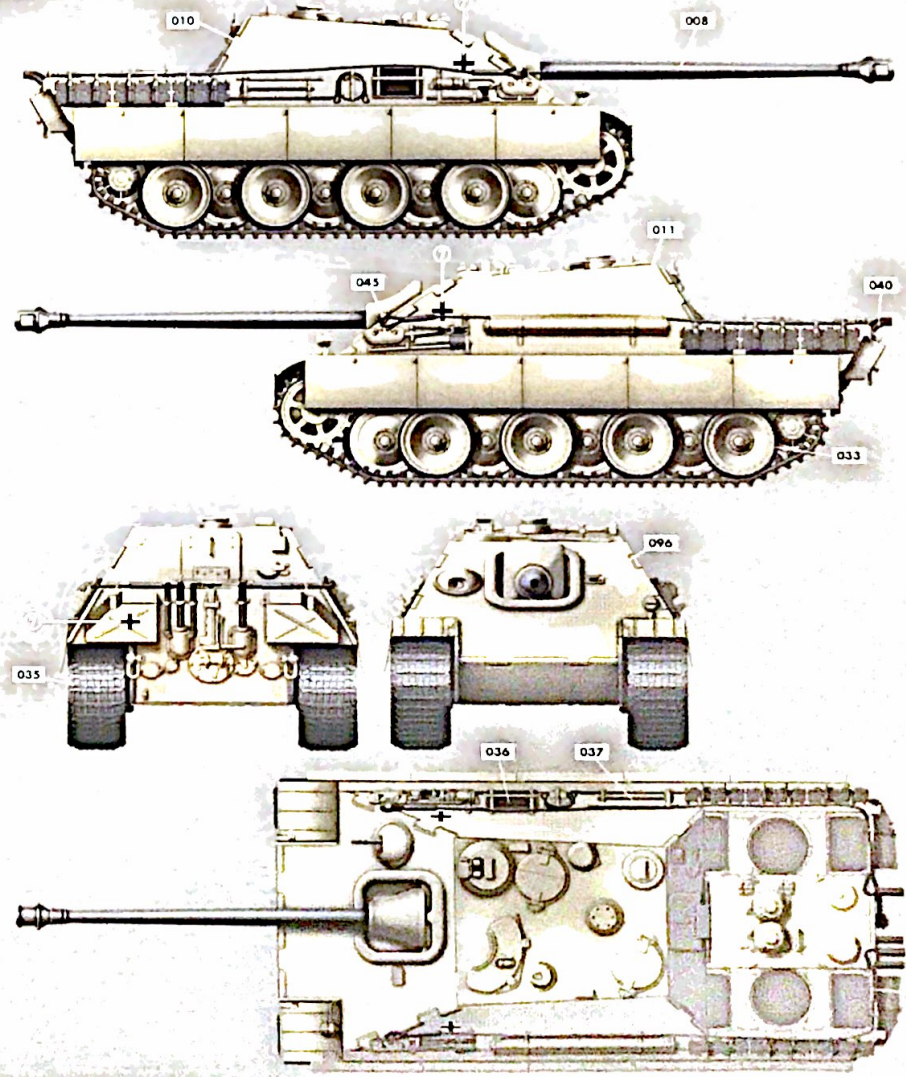

- 1 GENERAL WASH**
A.MIG-1000 Brown Wash for Dark Yellow
- 2 FILTER**
A.MIG-1011 Brown for Dark Yellow
- 3 STREAKING**
A.MIG-1254 Streaking/brusher Grime
- 4 TRACK WASH**
A.MIG-1002 Tracks Wash
- 5 RUST**
A.MIG-1254 Streaking/brusher Rust
- 6 DUST**
A.MIG-3011 Arfield Dust
- 7 MUD & SPLASHES**
A.MIG-1704 Heavy Earth / A.MIG-1753 Tanned Oil
- 8 GREASE & OIL**
A.MIG-1408 Fresh Engine Oil

Jagdpanther Ausf.G1

Painting and Marking Guide

TAKOM Ref: 2125

Jagdpanther Ausf.G1 Mid/Late Production

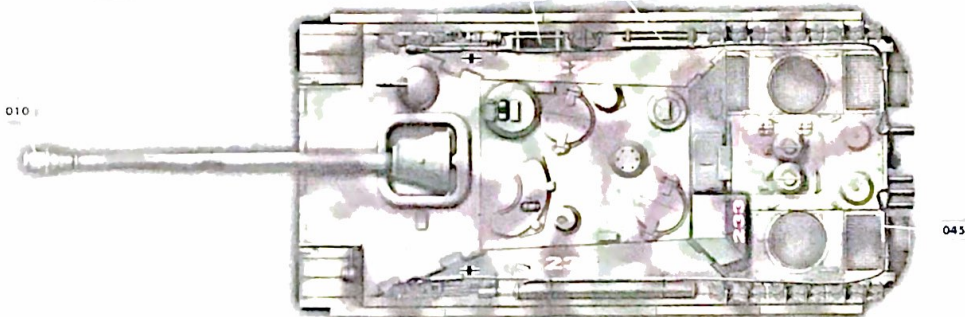
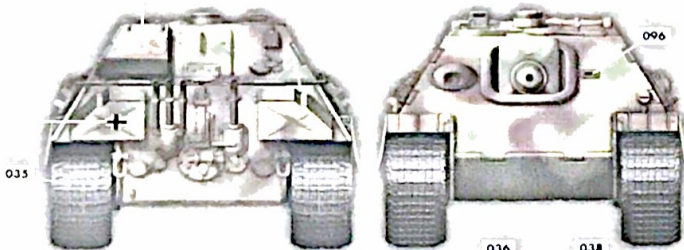
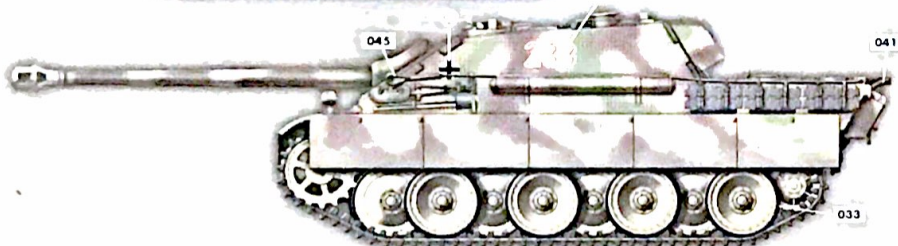
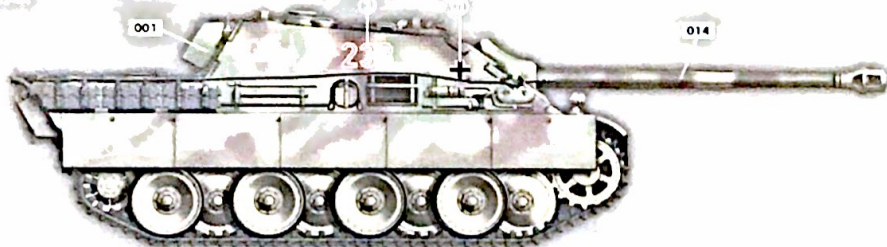

- 1 GENERAL WASH**
A MIG-1000 Brown Wash for Dark Yellow
- 2 FILTER**
A MIG-1510 Tan for 3 Tone Camo

- 3 STREAKING**
A MIG-1253 Streaking/brusher Grime
- 4 TRACK WASH**
A MIG-1002 Tracks Wash

- 5 RUST**
A MIG-1253 Streaking Rust Effects
- 6 DUST**
A MIG-3013 Rubble

- 7 MUD & SPLASHES**
A MIG-1700 Moss Ground / A MIG-1752 Loose Ground
- 8 GREASE & OIL**
A MIG-1408 Fresh Engine Oil

Jagdpanther Ausf.G1

Painting and Marking Guide

TAKOM Ref: 2125

Jagdpanther Ausf.G1 Mid/Late Production

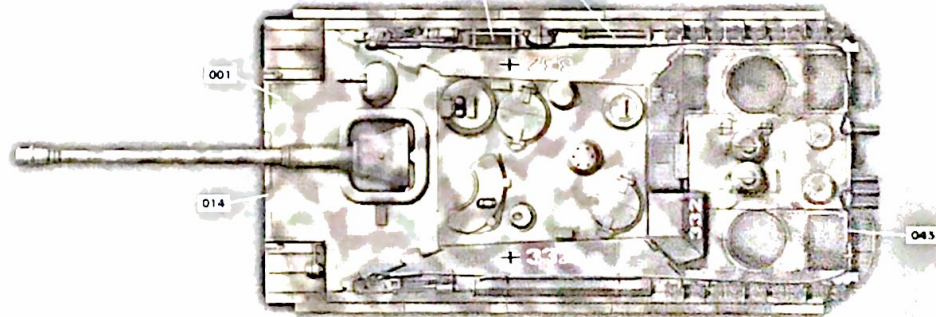
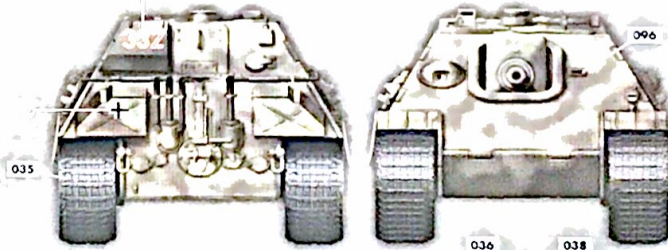
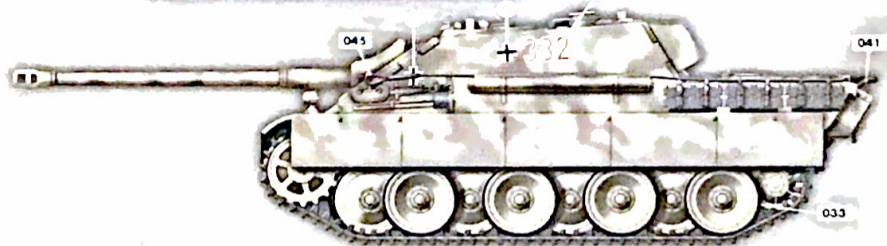
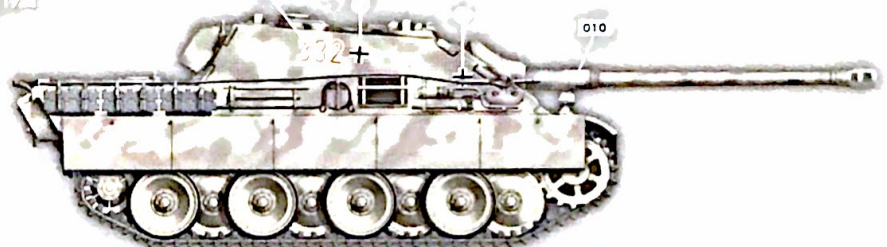

- 1 GENERAL WASH**
A MIG-1008 Dark Wash
- 2 FILTER**
A MIG-1510 Tan for 3 Tone Camo

- 3 STREAKING**
A MIG-1258 Streaking/brusher Green-Gray Grime
- 4 TRACK WASH**
A MIG-1002 Tracks Wash

- 5 RUST**
A MIG-1204 Streaking Rust Effects
- 6 DUST**
A MIG-3004 Europe Earth

- 7 MUD & SPLASHES**
A MIG-1704 Heavy Earth / A MIG-1753 Toned Dirt
- 8 GREASE & OIL**
A MIG-1408 Fresh Engine Oil

2023/2125W

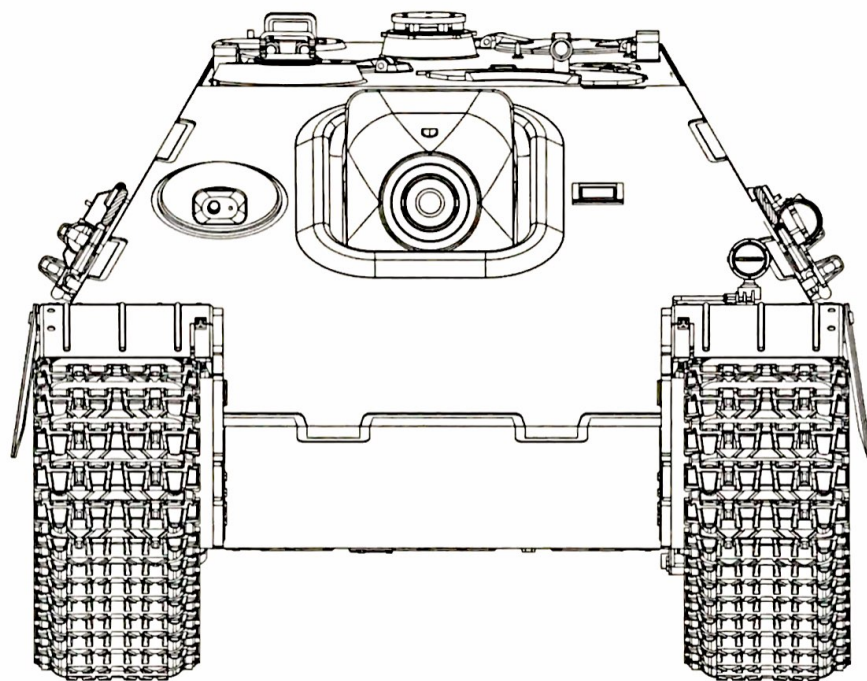

You can find TAKOM on Facebook.com