



Photo by: Jake Melampy

F-16F UNITED ARAB EMIRATES AIR FORCE

The twin-seat Block 60 F-16F Desert Falcon is being developed for the United Arab Emirates Air Force and is the latest and most advanced F-16 variant fielded ever. It features conformal fuel tanks, the AN/APG-80 agile beam radar, advanced weapons compatibility, an internally mounted FLIR targeting system, a new glass cockpit, internal countermeasures, the F110-GE-132 engine and enhanced performance.

The United Arab Emirates Air Force ordered a total of 80 F-16E/F Block 60 aircraft (55 F-16Es and 25 F-16Fs) in 1998, becoming the first customer for this advanced version of the F-16. Given that the Block 60 has only been offered to the United Arab Emirates, all development costs have been paid for by the UAE. The UAE have linked a potential order to the availability of the AIM-120 AMRAAM.

The first UAEAF F-16 Block 60 made its maiden flight at Lockheed's facilities in Fort Worth, Texas on December 6th, 2003. The aircraft's designation, F-16E/F, recognizes the major structural, avionics and propulsion enhancements in this practically all-new version of the F-16.

The UAE purchased USD \$2 billion in sophisticated aircraft armament for its F-16s, including 491 AIM-120B AMRAAM Missiles, 267 AIM-9M Sidewinder, 163 AGM-88 Harm, 1,163 AGM-65D/G Maverick, 52 AGM-84 Harpoon, laser guided bombs, 20mm ammunition and other sophisticated weaponry.

H1	1	White
H2	2	Black
H4	4	Yellow
H5	5	Blue
H8	8	Silver
H9	9	Gold
H52	12	Olive Drab

H18	28	Steel
H12	33	Flat Black
H90	47	Clear Red
H91	48	Clear Yellow
H50	50	Clear Blue
H76	61	Brunt Iron
H28	78	Metal Black

H305	305	Gray FS36118
H306	306	Gray FS36270
H307	307	Gray FS36320
H308	308	Gray FS36375
H338	338	Light Gray FS36495

H1 GSI Creos Aqueous Hobby color

1 GSI Mr.Color

Glue is not included in this kit.

1/48 SCALE AIRCRAFT SERIES NO.08 - F-16F

! CAUTION

- *Read carefully and understand fully the instructions before commencing assembly.
- *Keep out of reach of children. Children must not be allowed to put any parts in their mouths, or pull plastic bag over their heads.
- *When using adhesives and paints, please make sure not to use them in closed room or near the fire.
- *When assembling this kit, tools including knives are used. Extra care should be taken to avoid injury.

WARNING: CONTAIN SMALL PARTS NOT FOR CHILDREN UNDER 14 YEARS OF AGE.

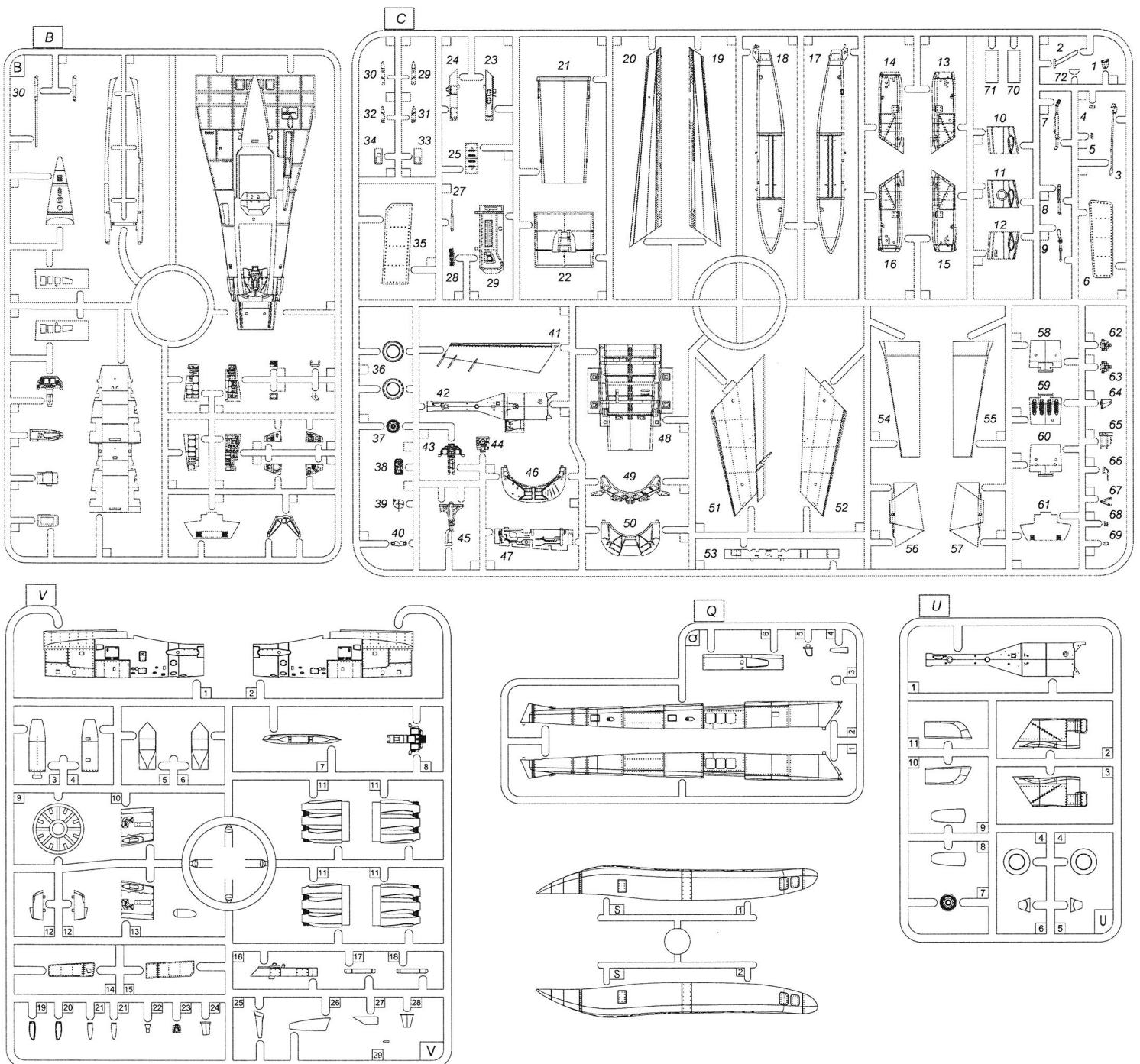

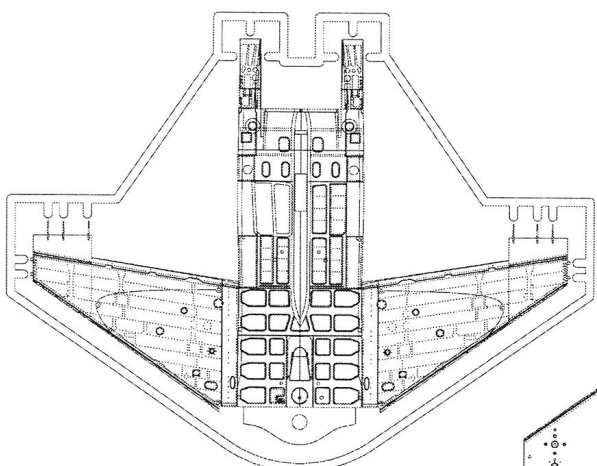
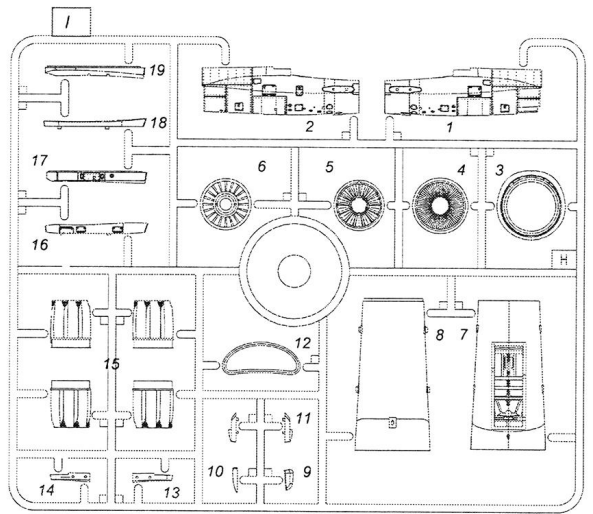
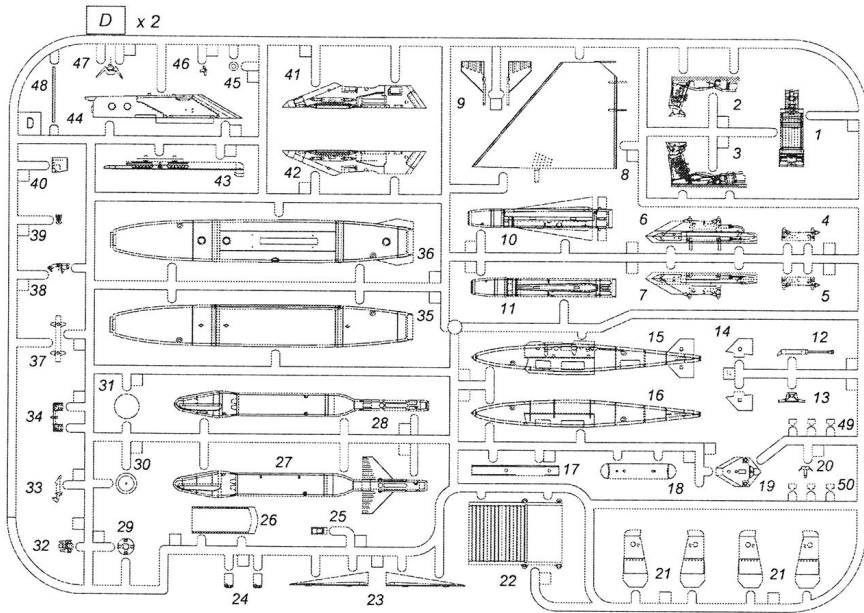

Upper fuselage

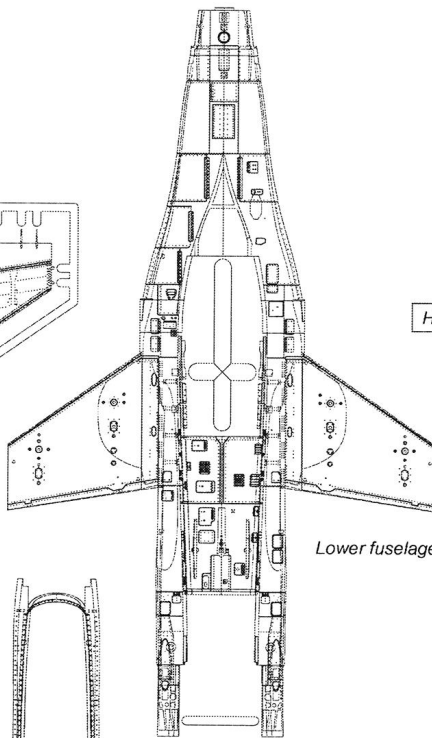

Lower fuselage

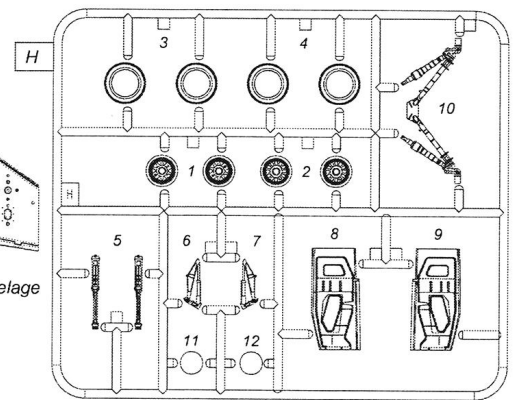
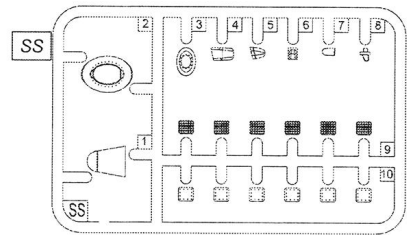
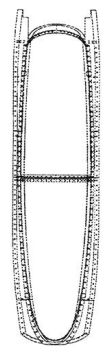
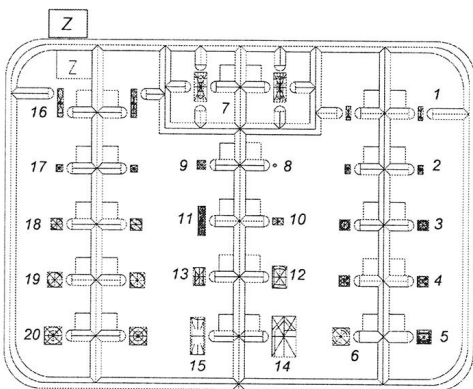

Photo etch part for CFT x 1



canopy



nose cone

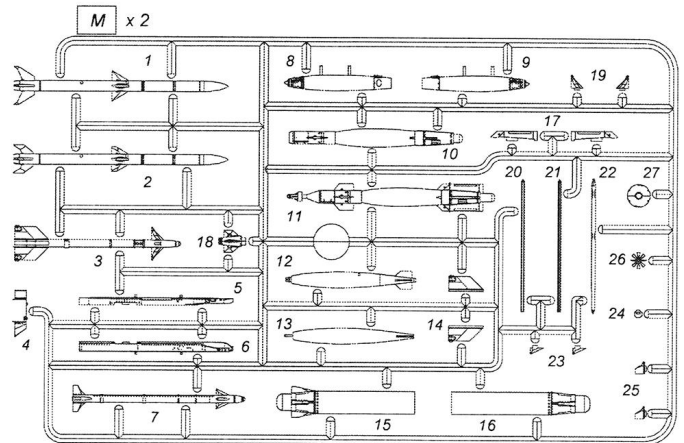

Some parts are not for use. For those parts not shown in the construction manual, please simply neglect them as they will not be used for building this model.

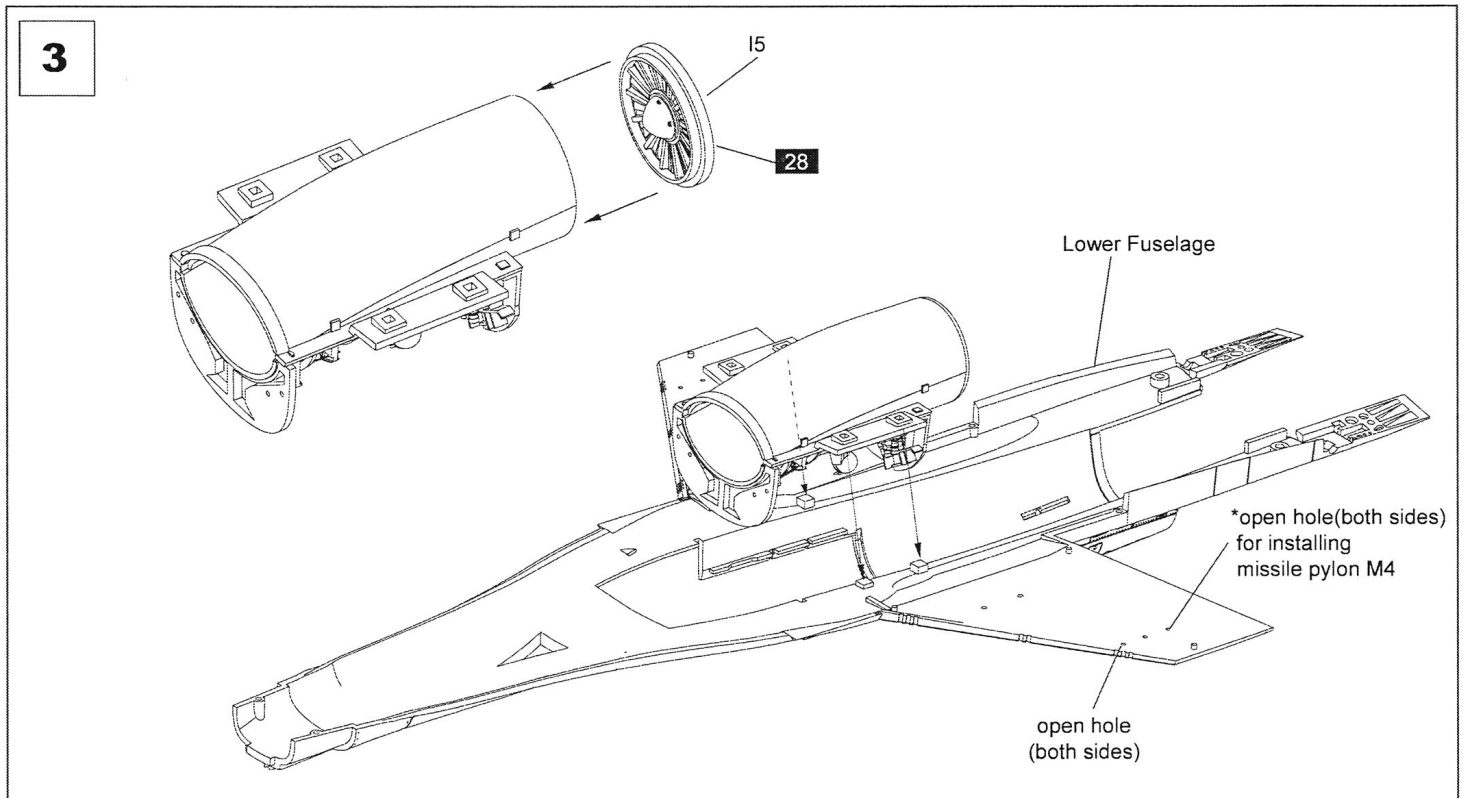
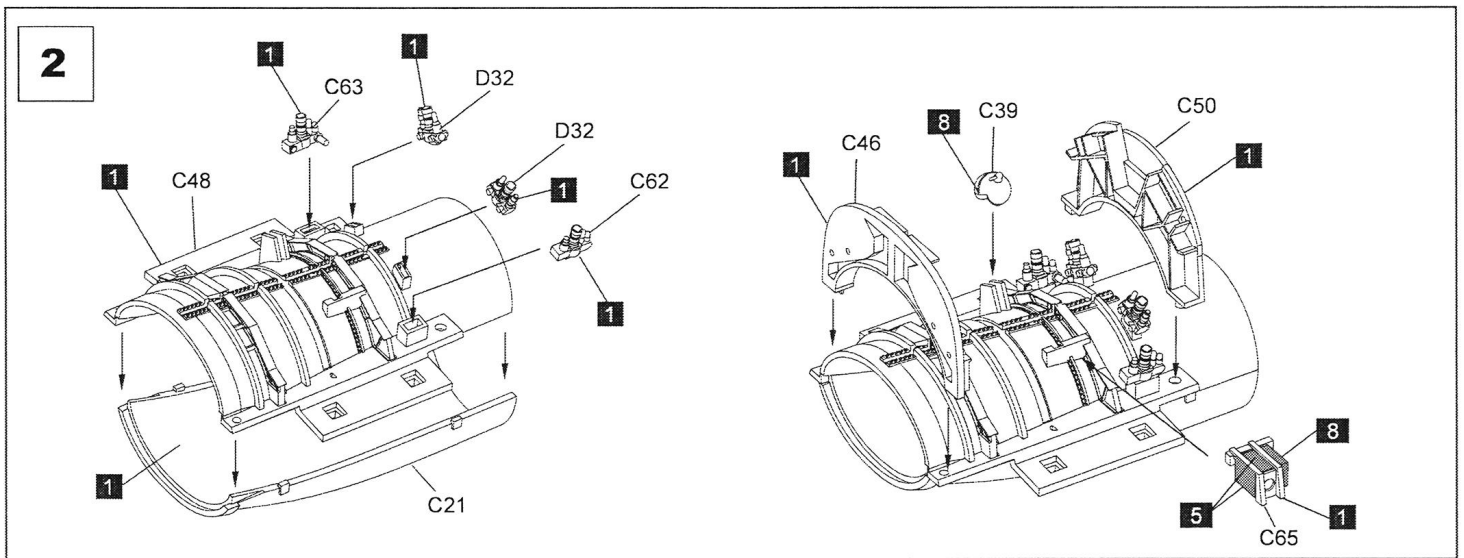
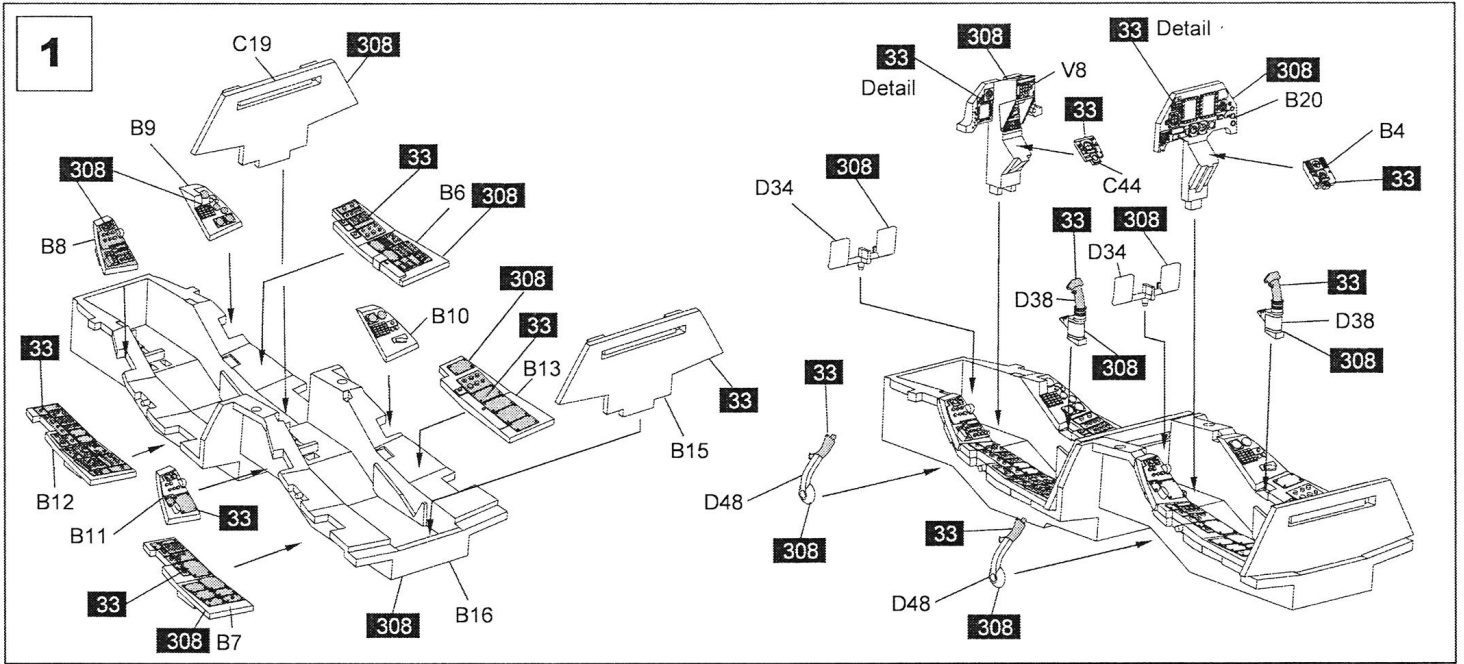

4

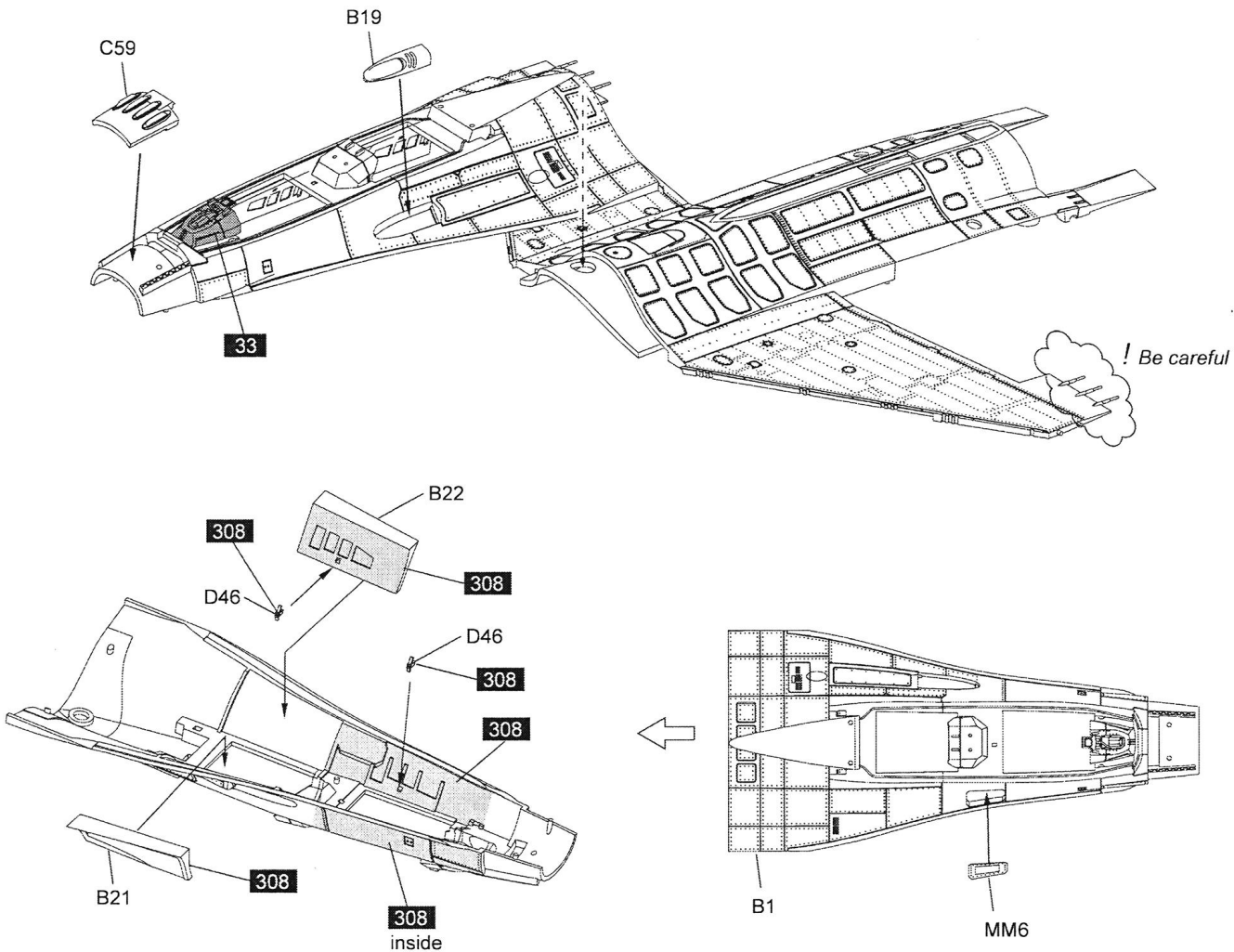

5

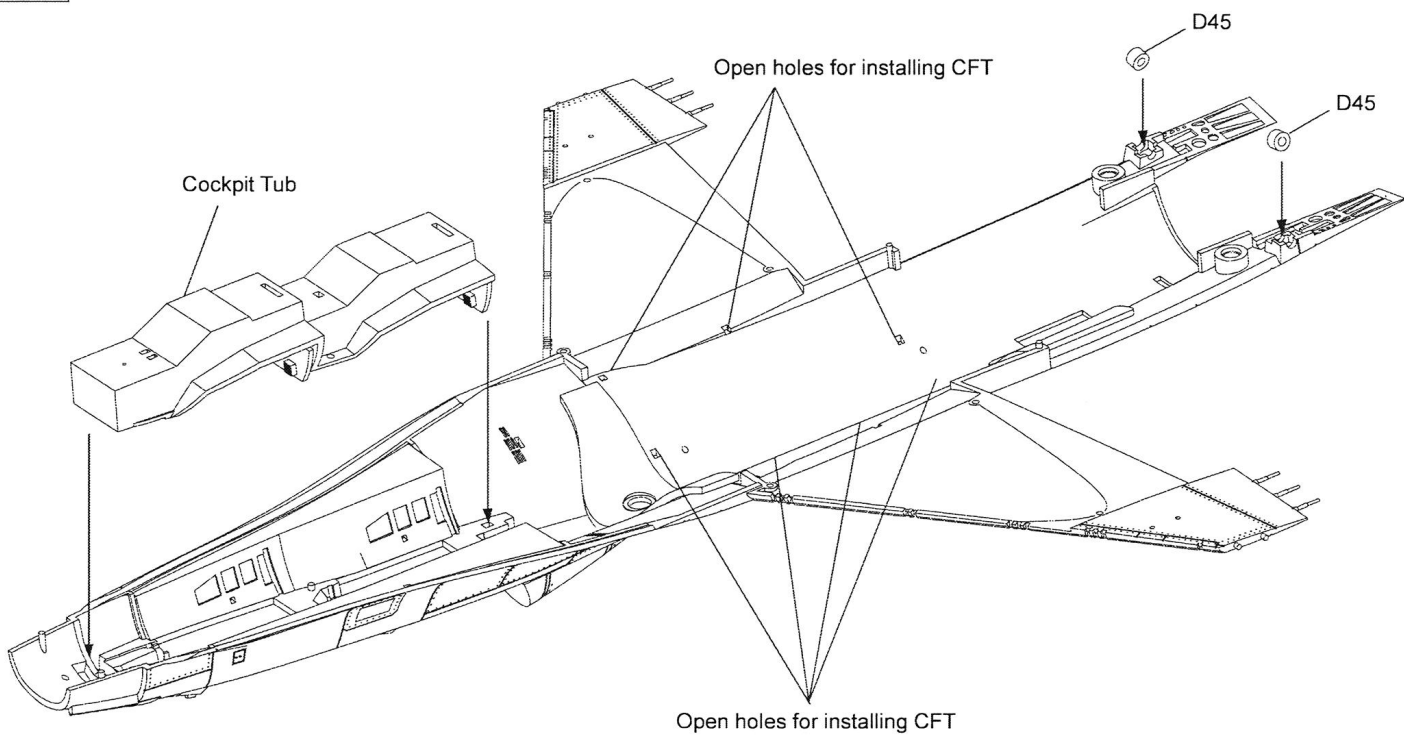

6

Cut along the lines for open air brake

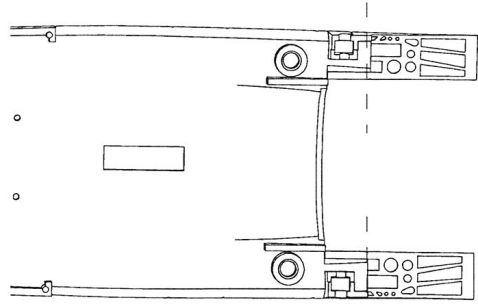

Upper Fuselage

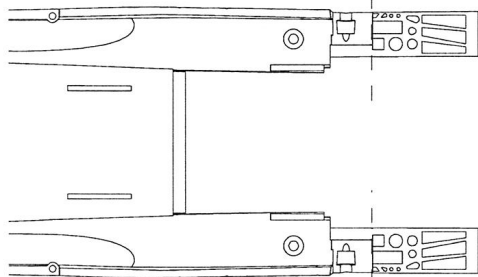

Lower Fuselage

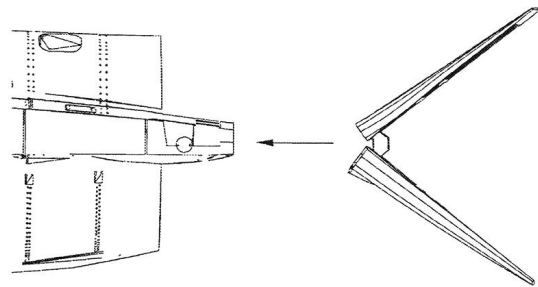
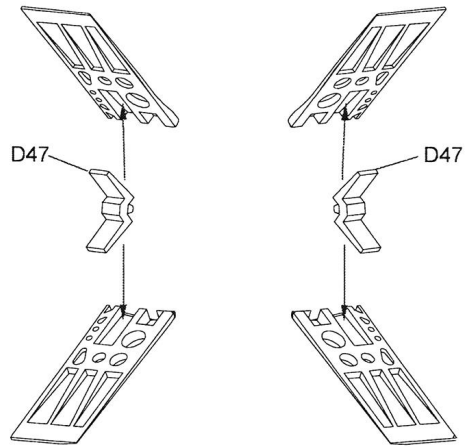

7

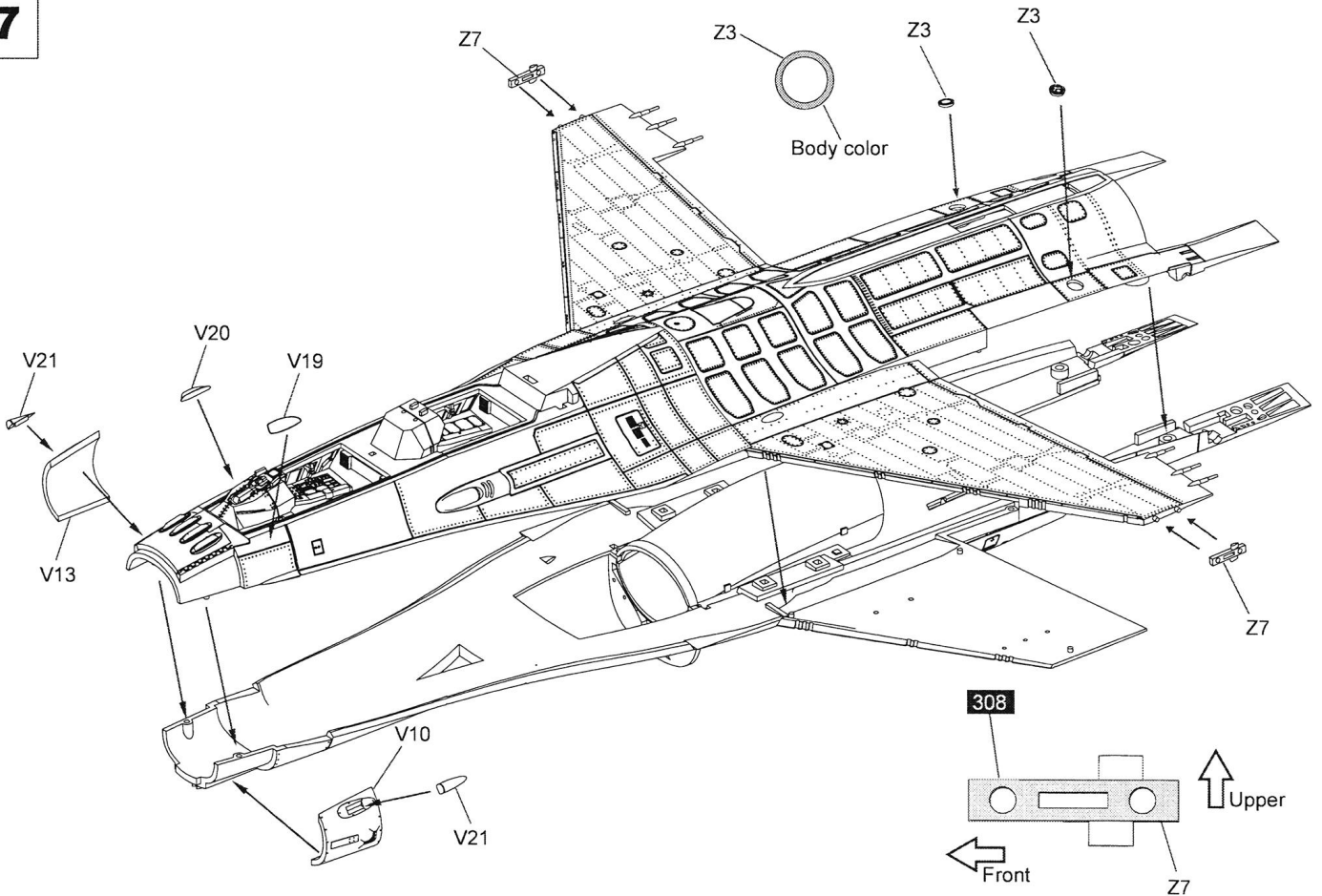

8

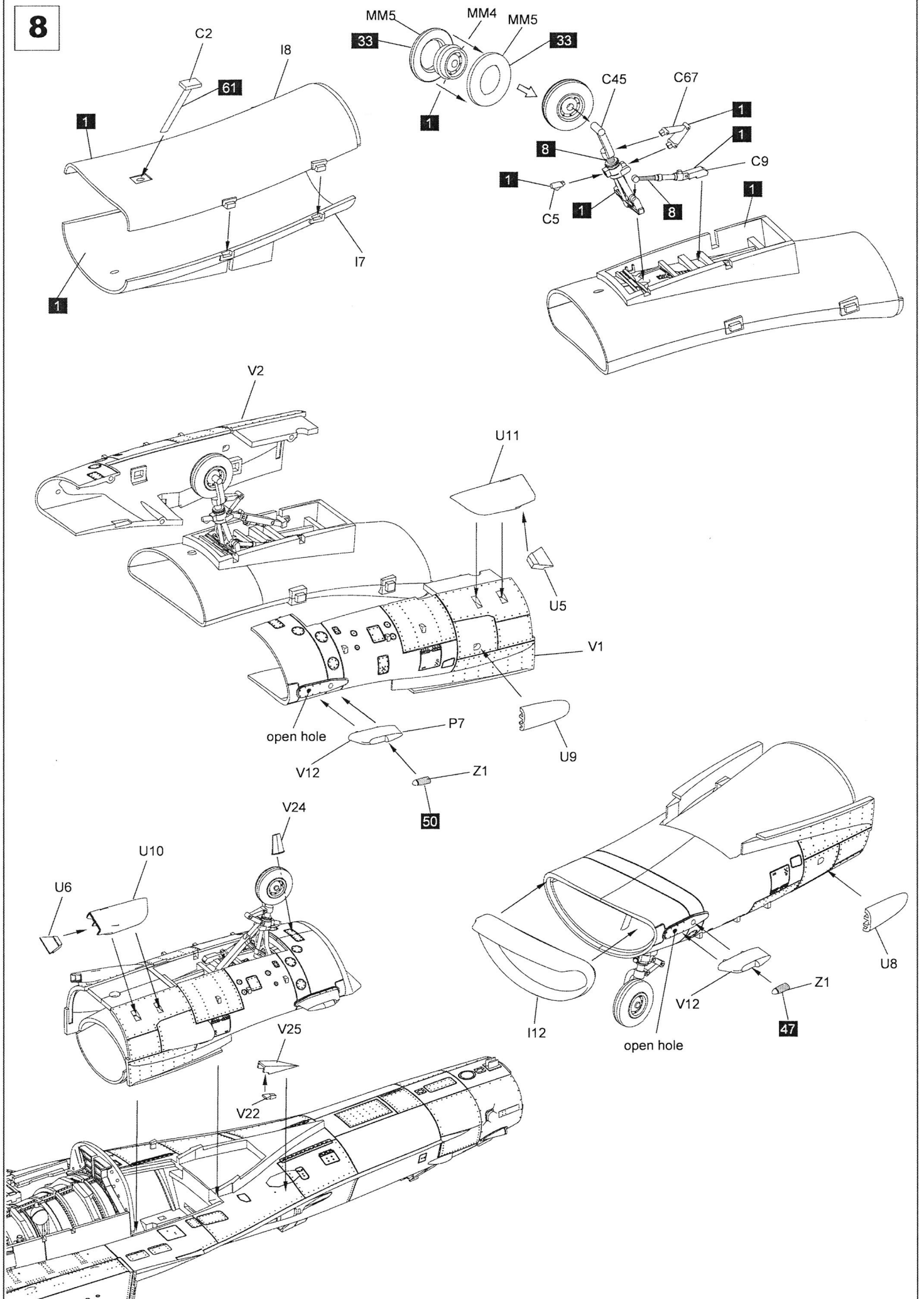

9

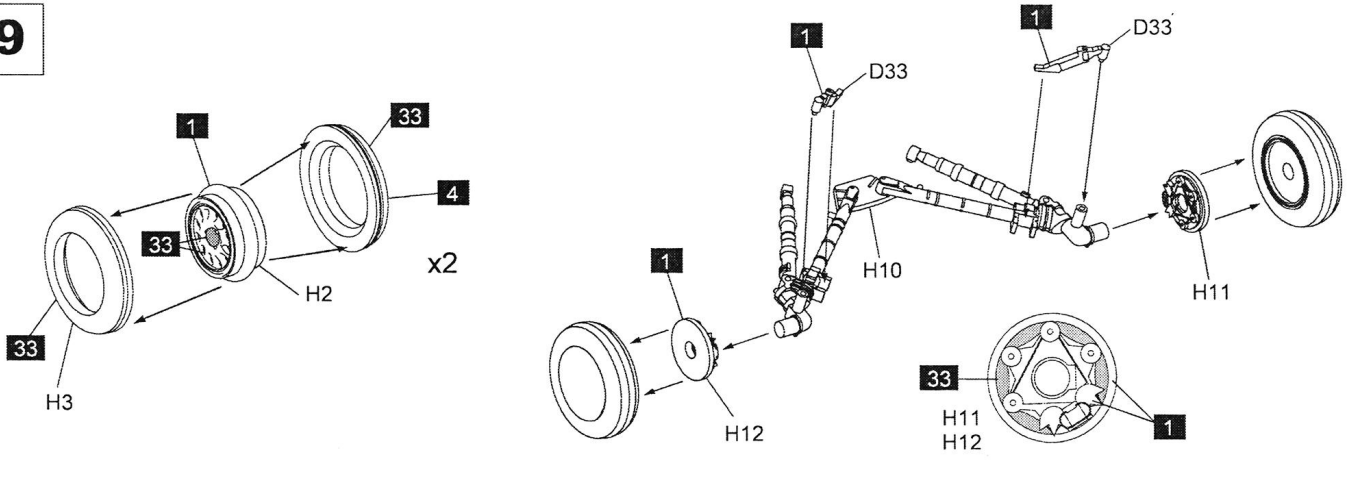

10

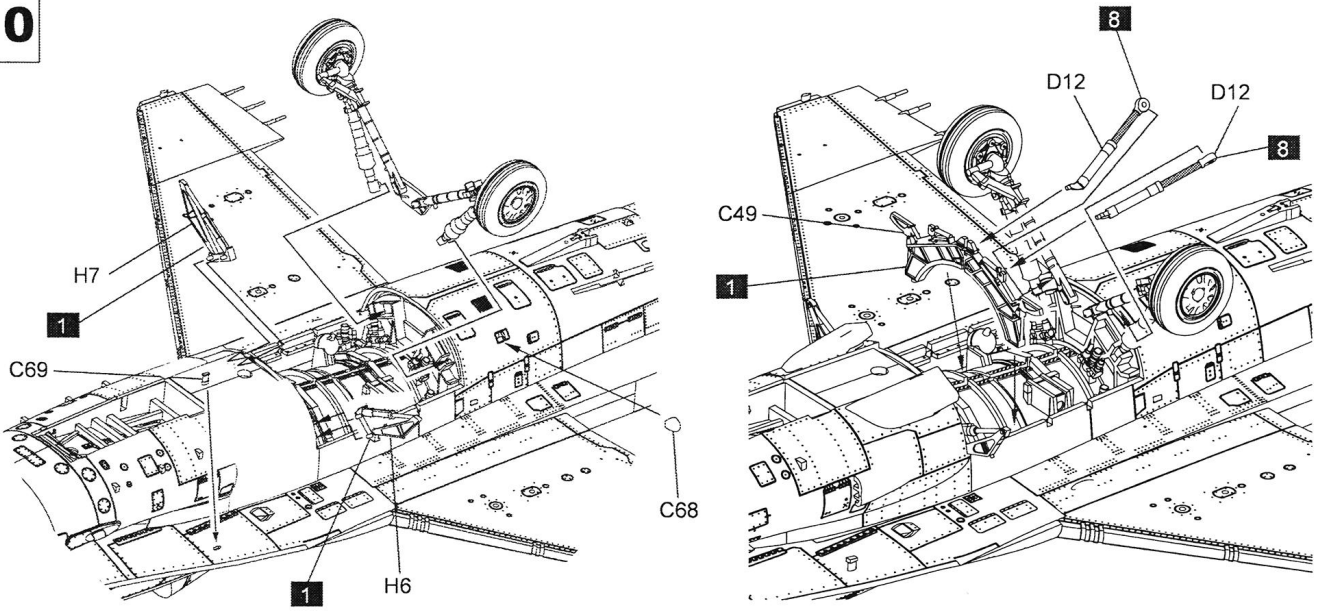

11

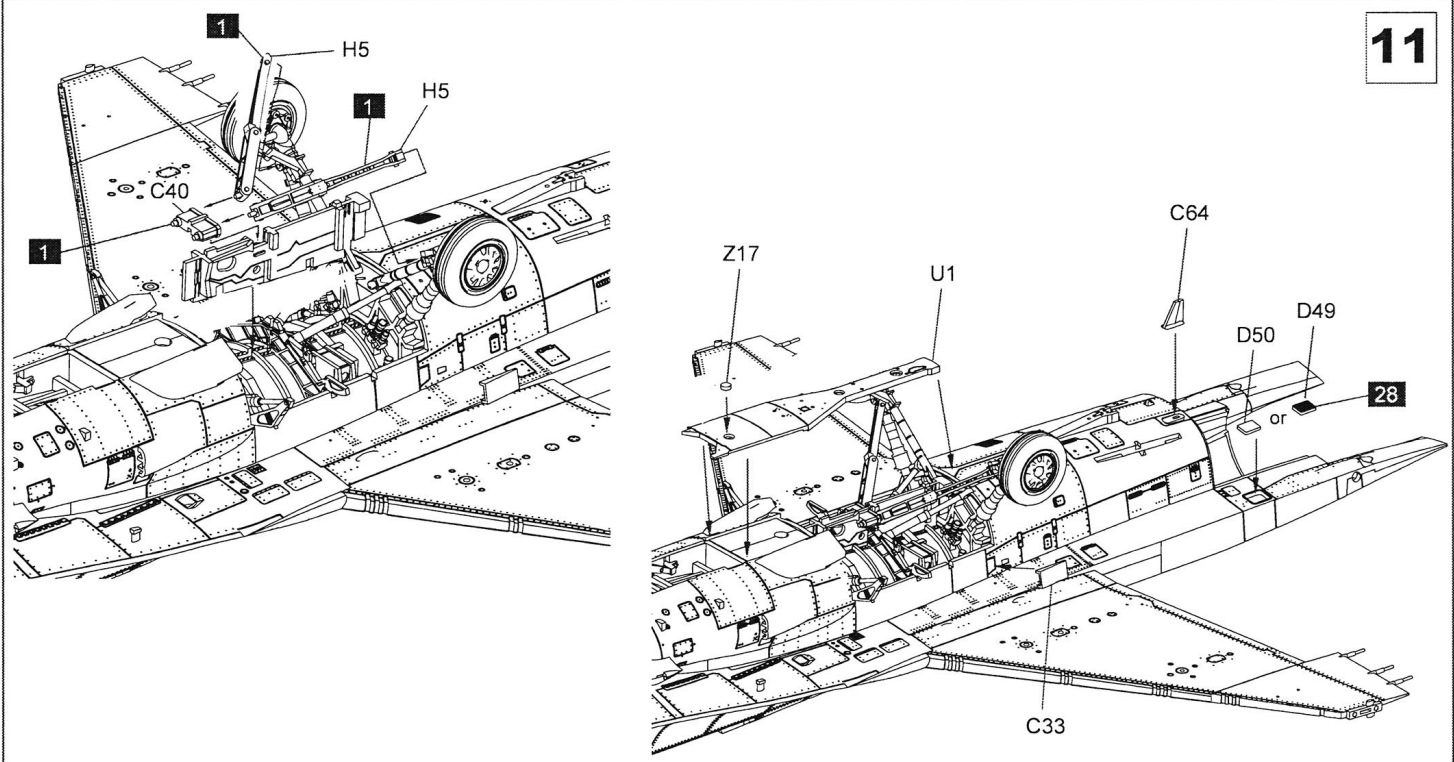

12

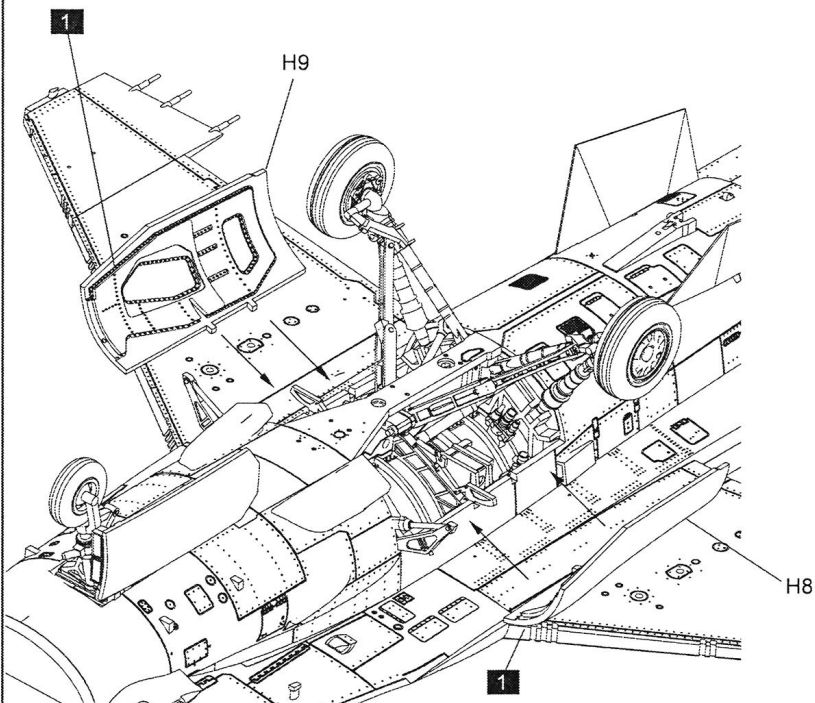
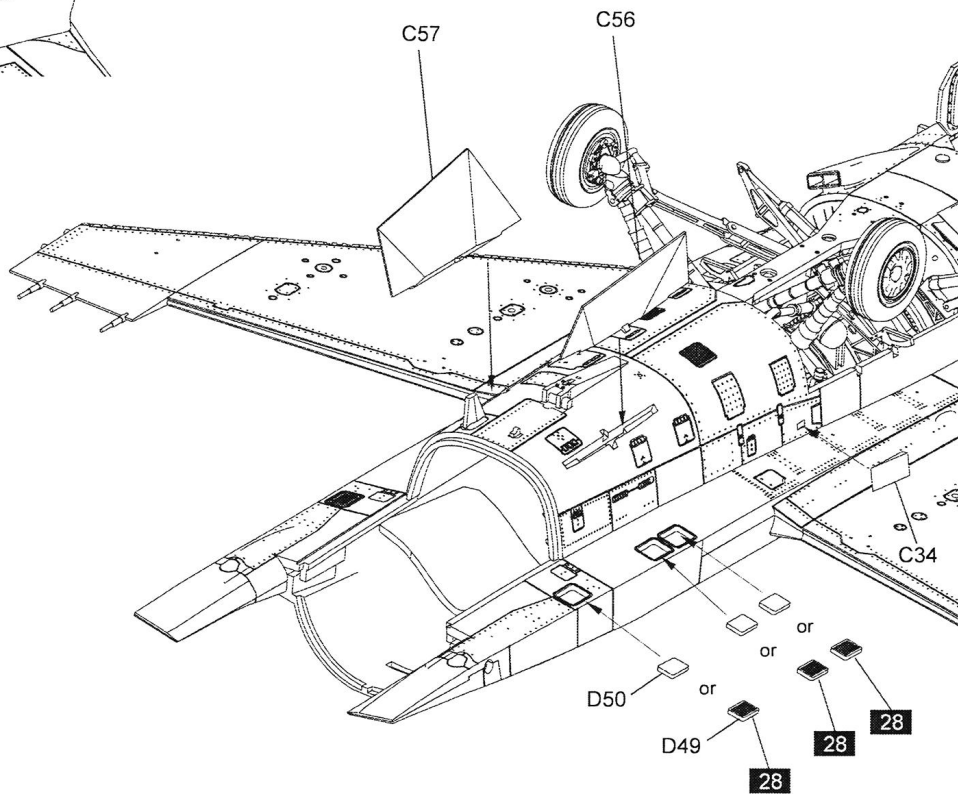
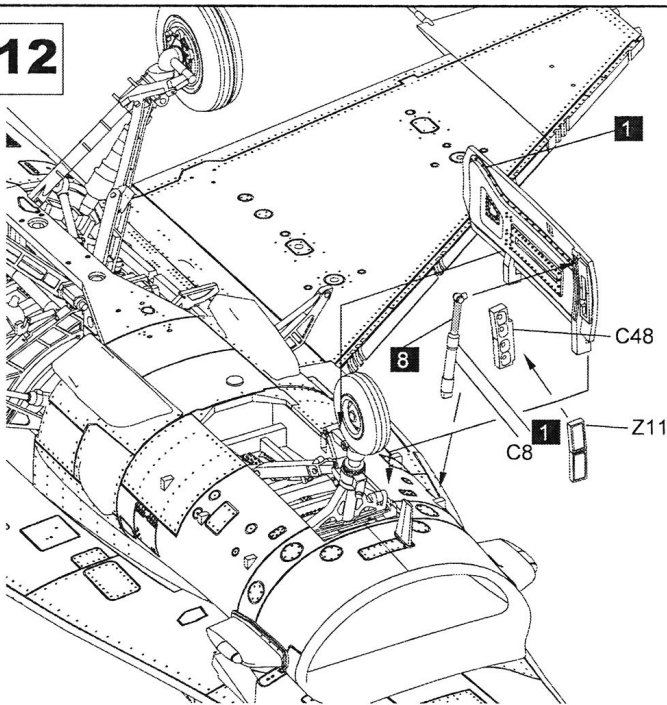

13

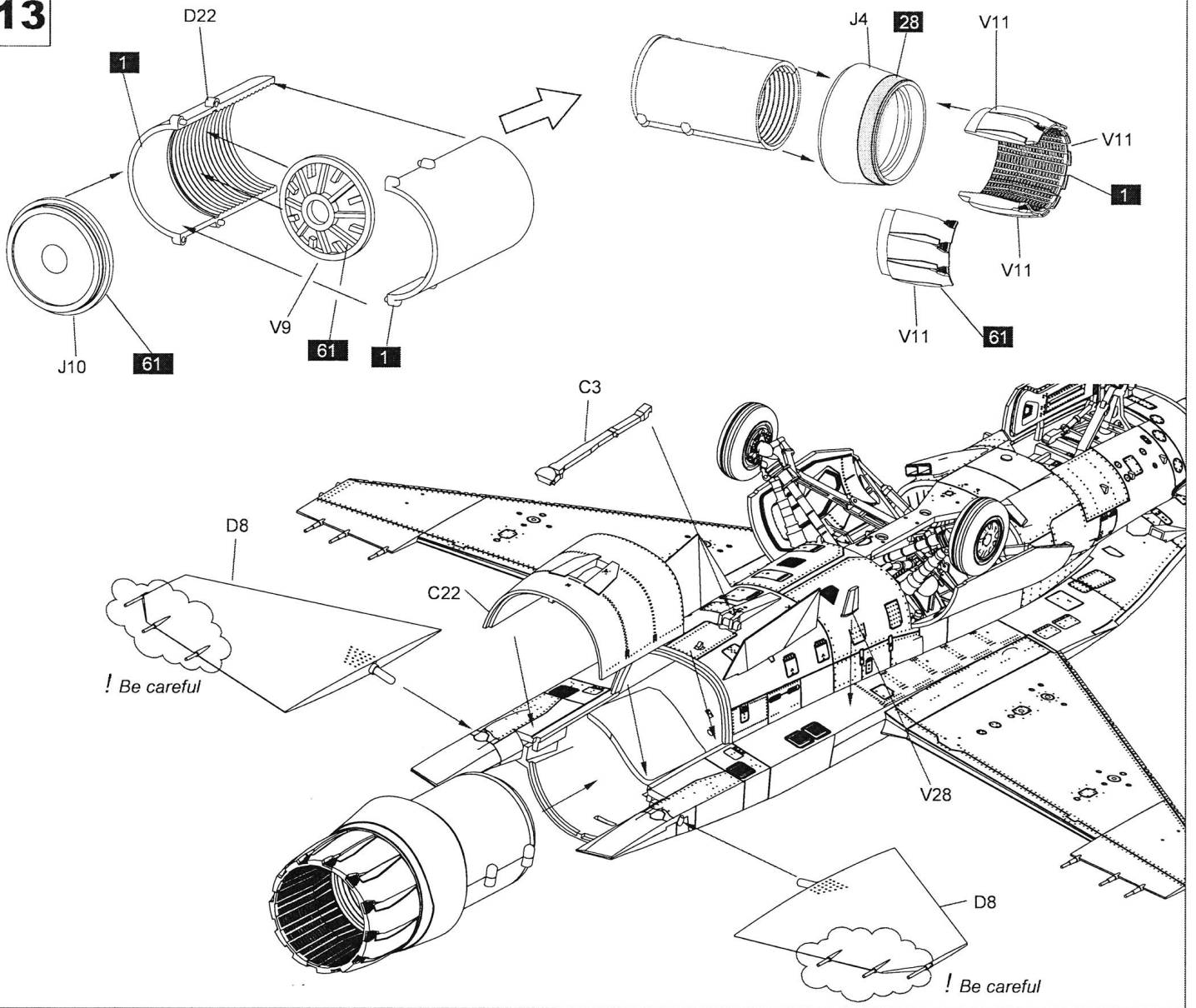

14

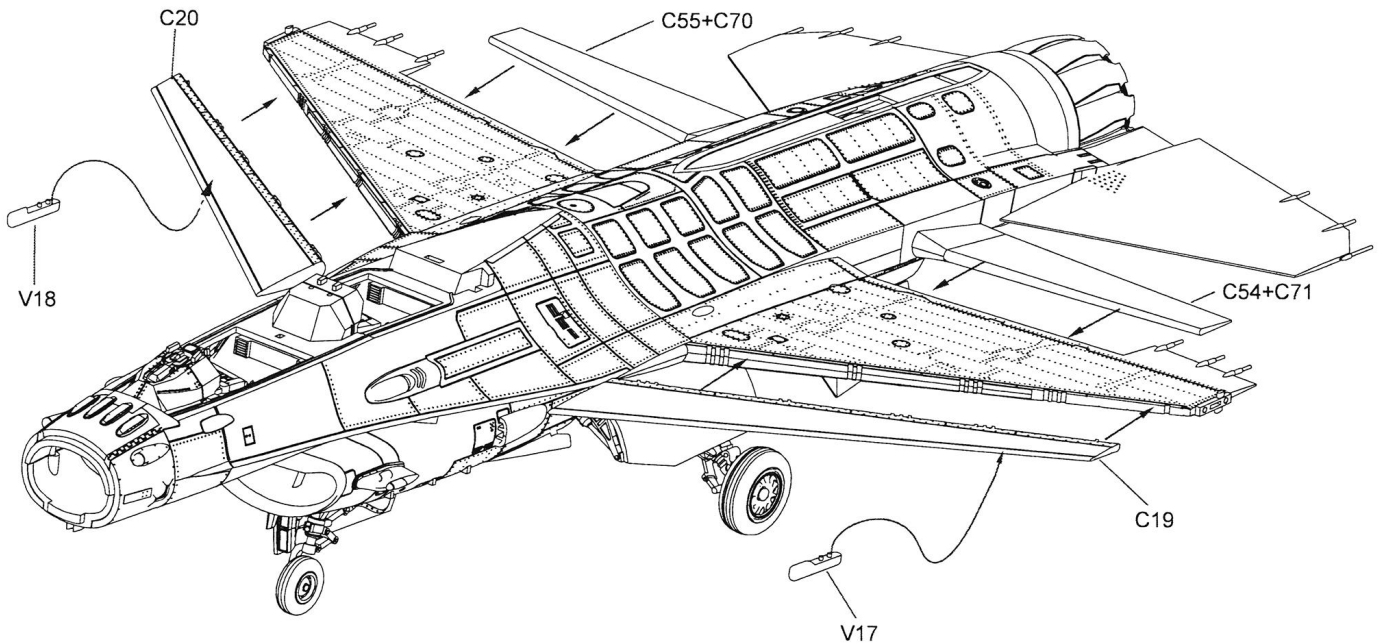

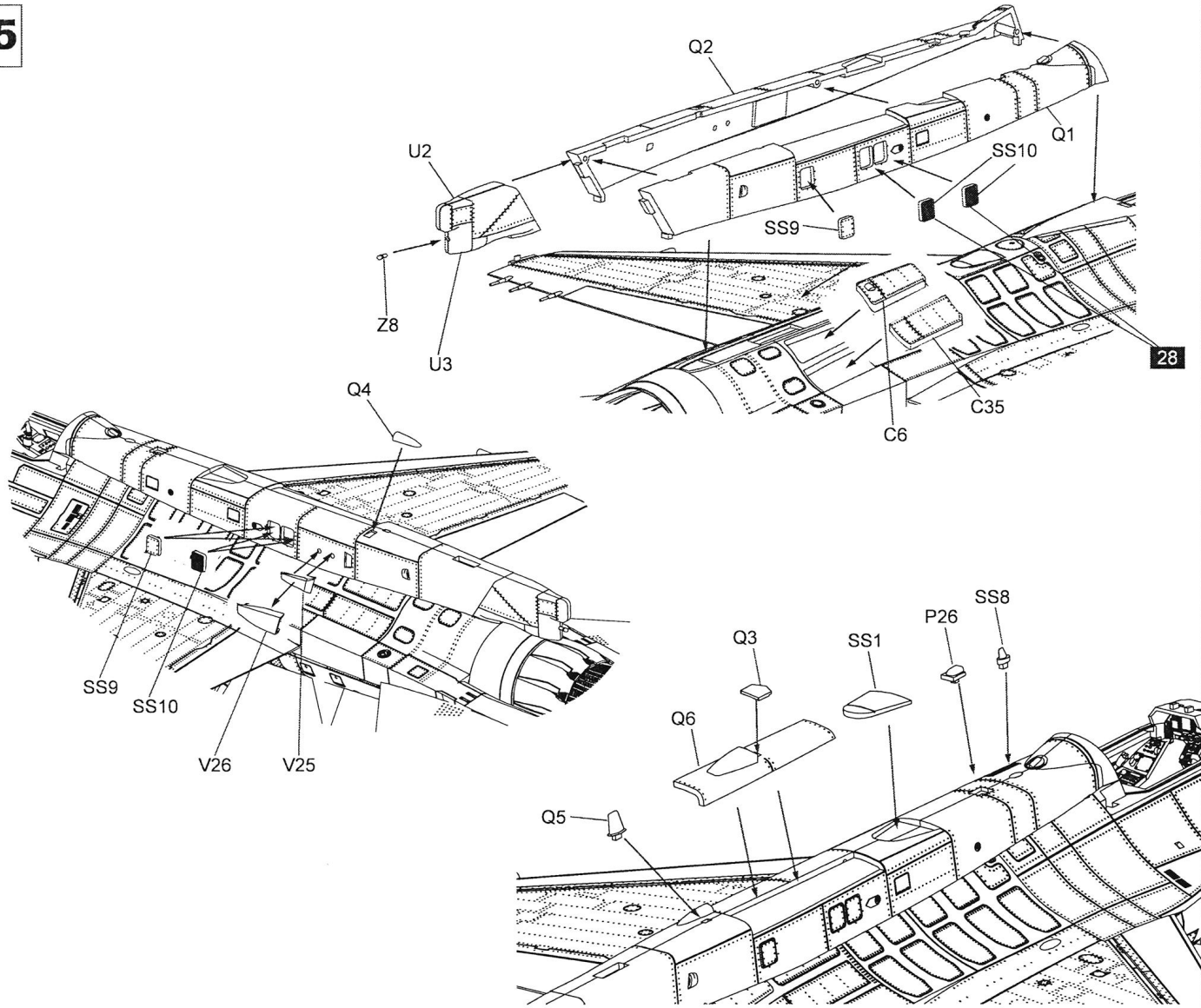

28

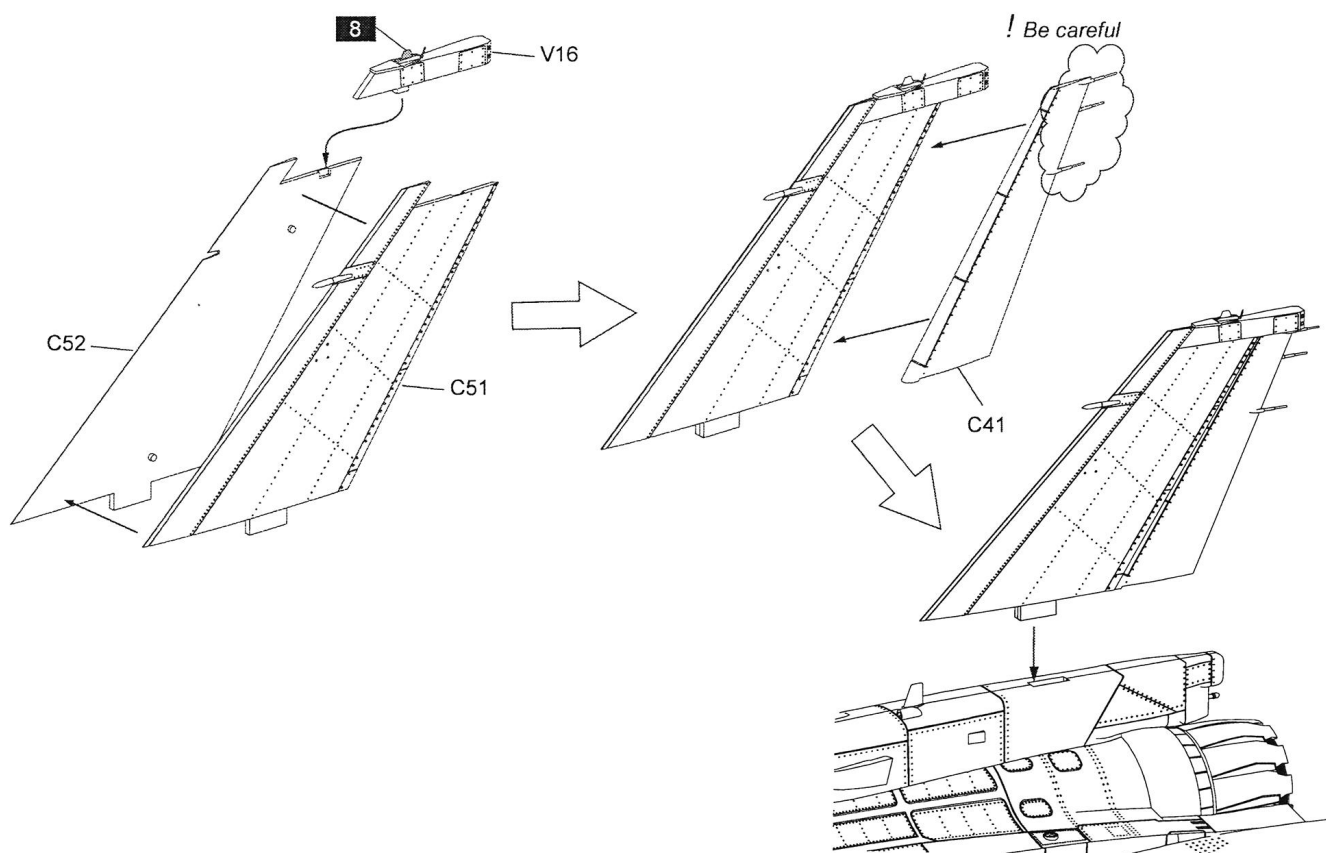

16

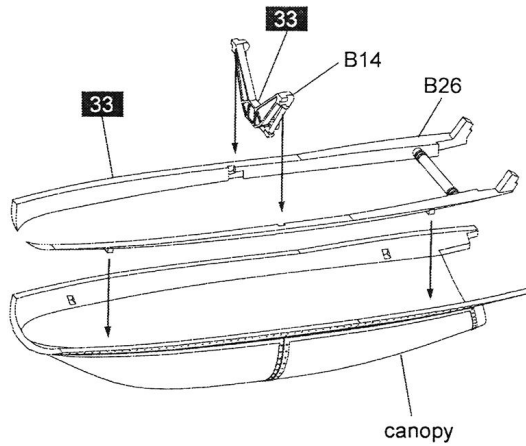
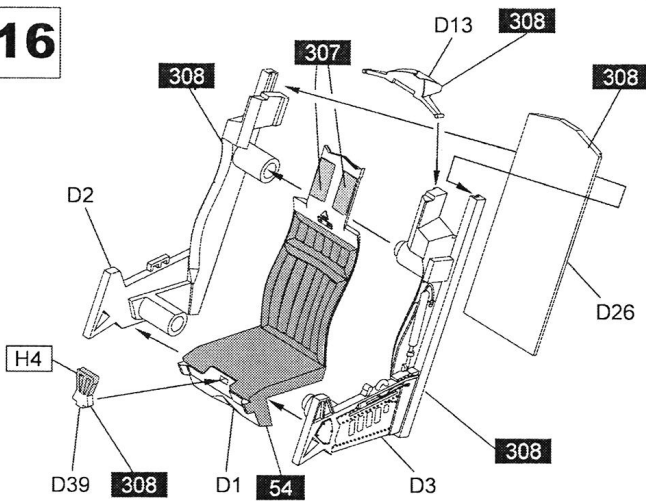

17

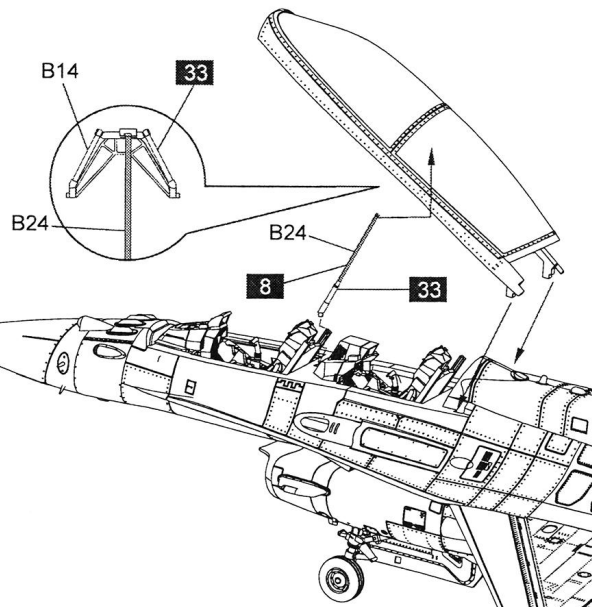
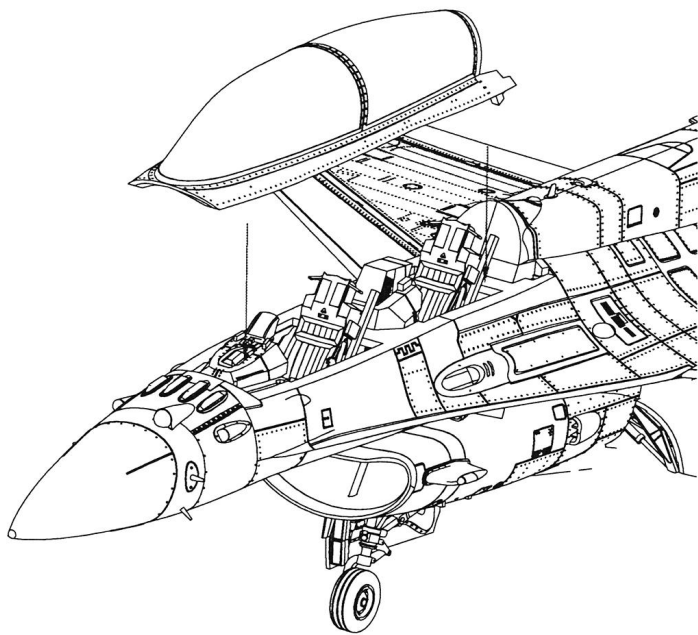
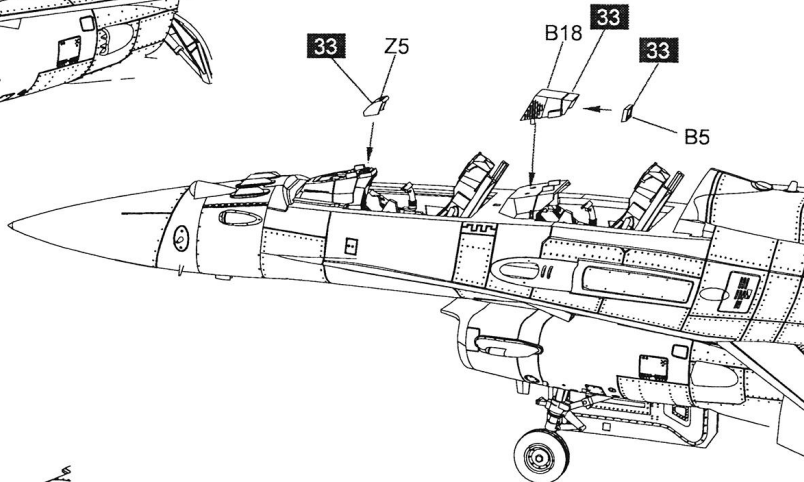
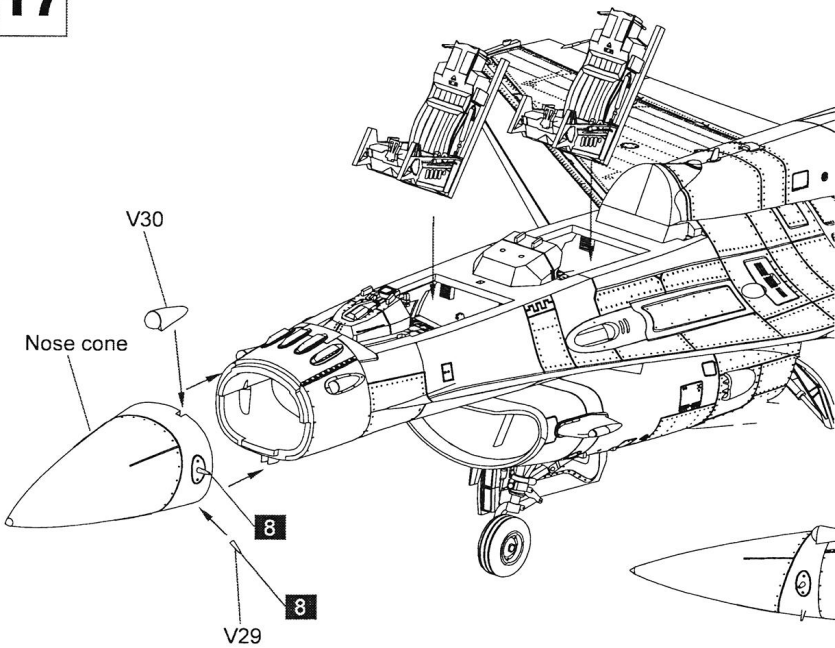

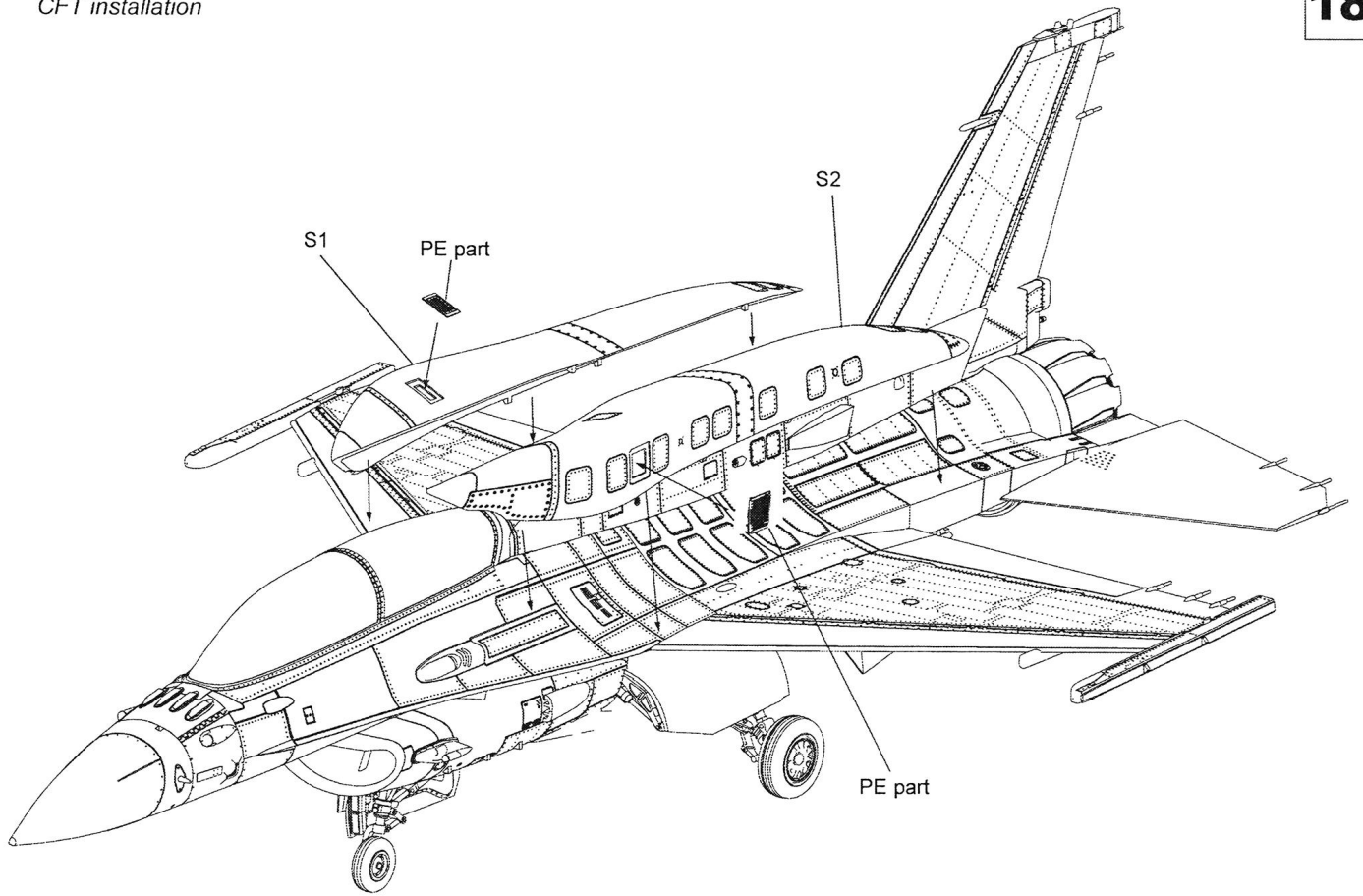

370 Gallon Wing Tank

300 Gallon Centerline Tank

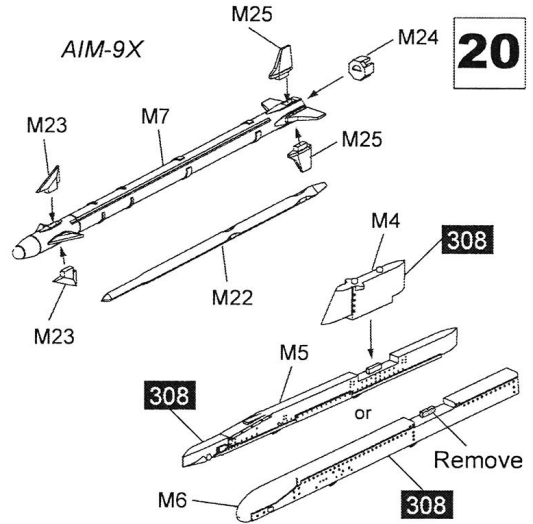
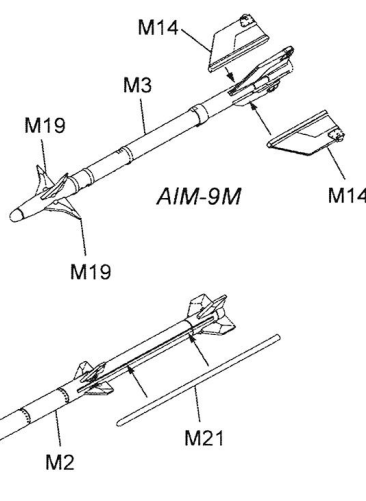
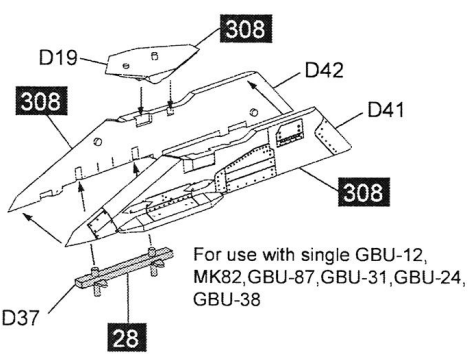
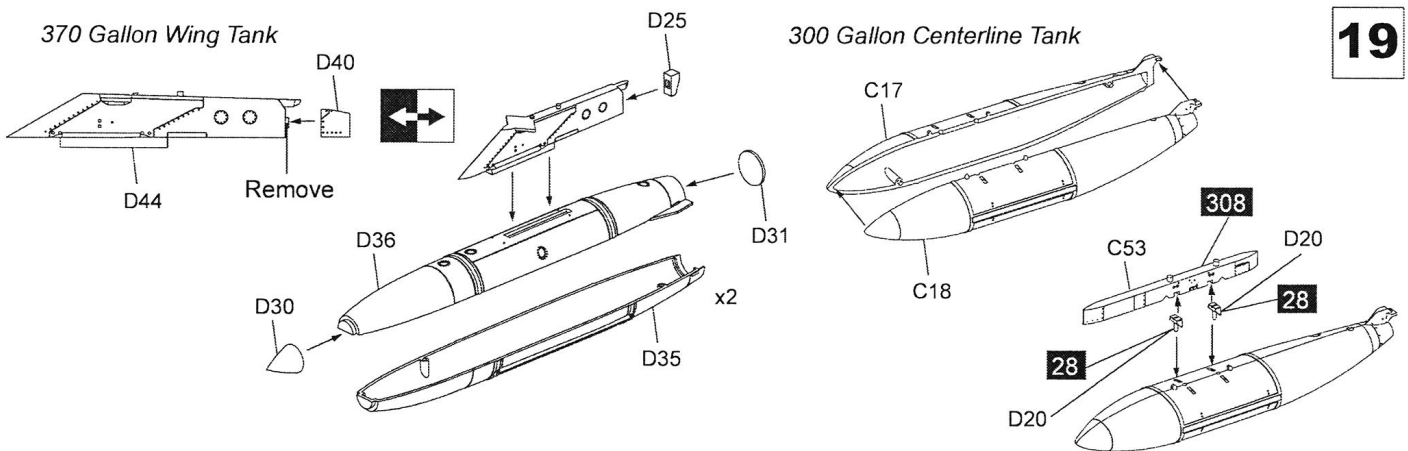

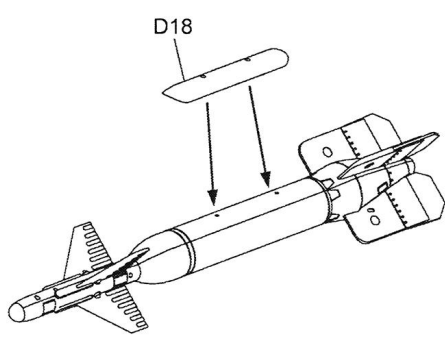
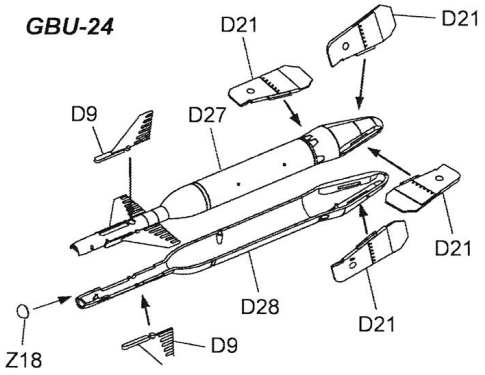
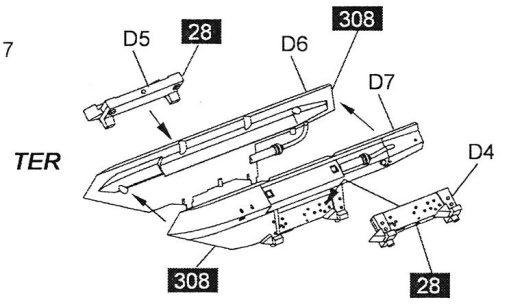
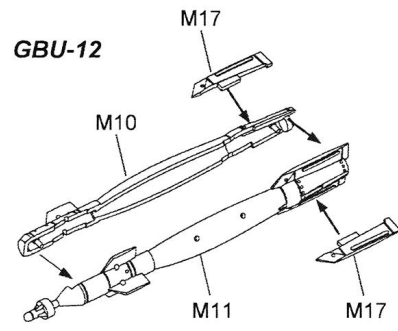
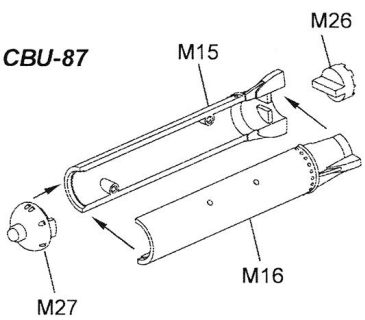
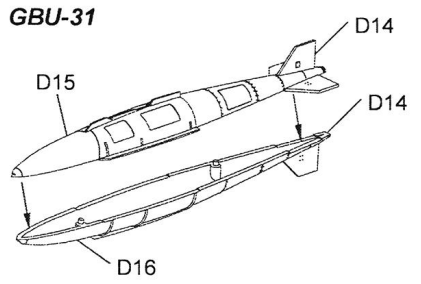
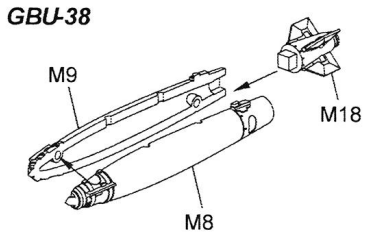
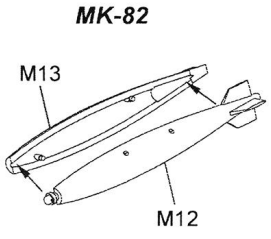
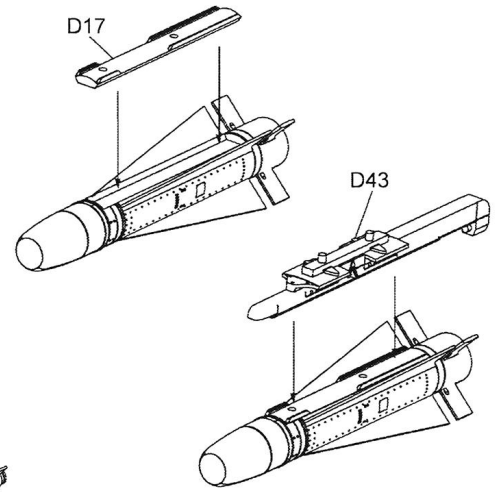
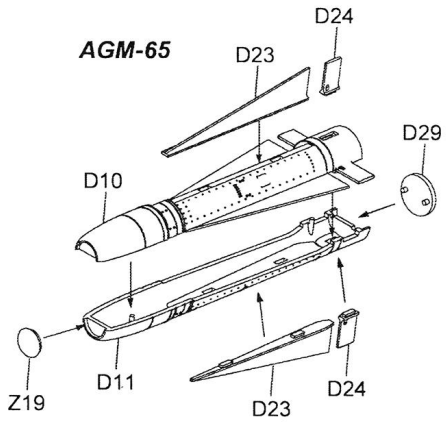

AN/AAQ-32

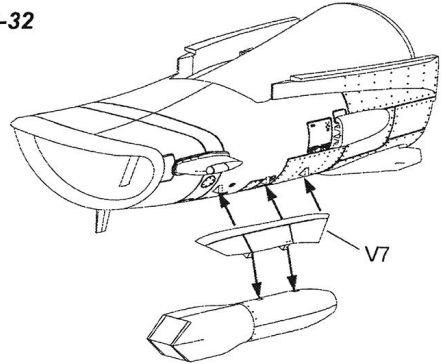
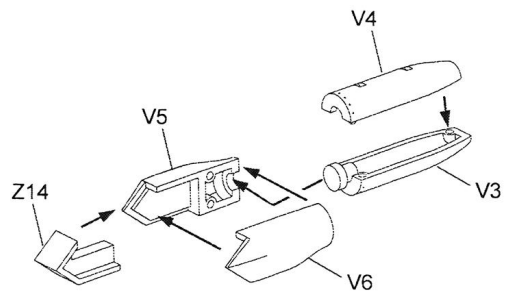

Painting & Decal Placement - External Stores (F-16 C/D)

Fuel Tank

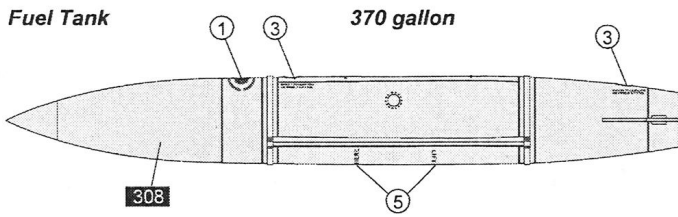

300 gallon

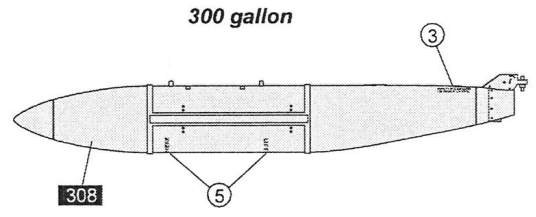

AIM-120C

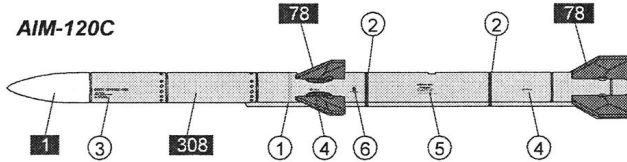

AIM-9M

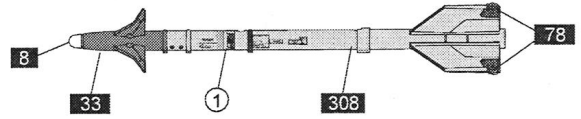

GBU-12

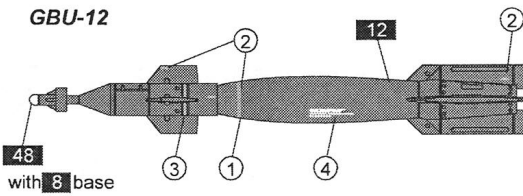

AIM-9X

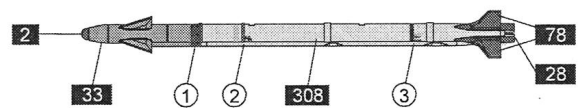

MK.82

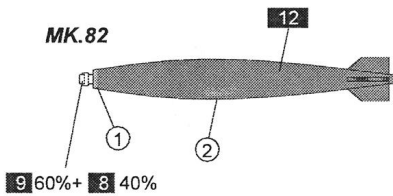

GBU-31

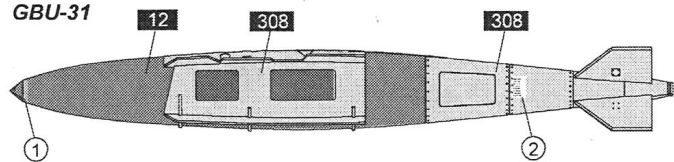

GBU-38

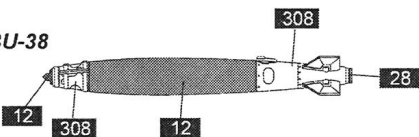

CBU-87

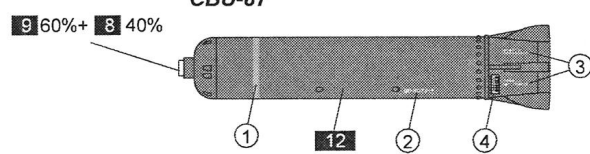

GBU-24

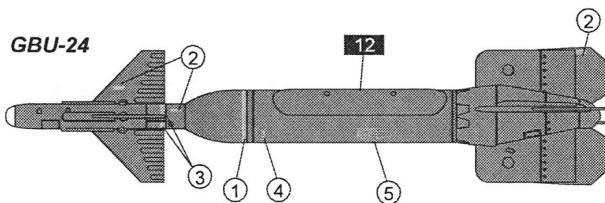

AGM-65

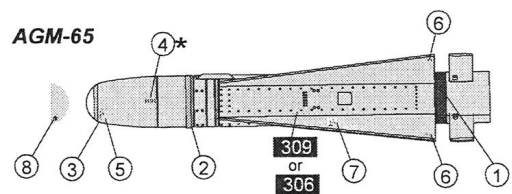

EXTERNAL STORES

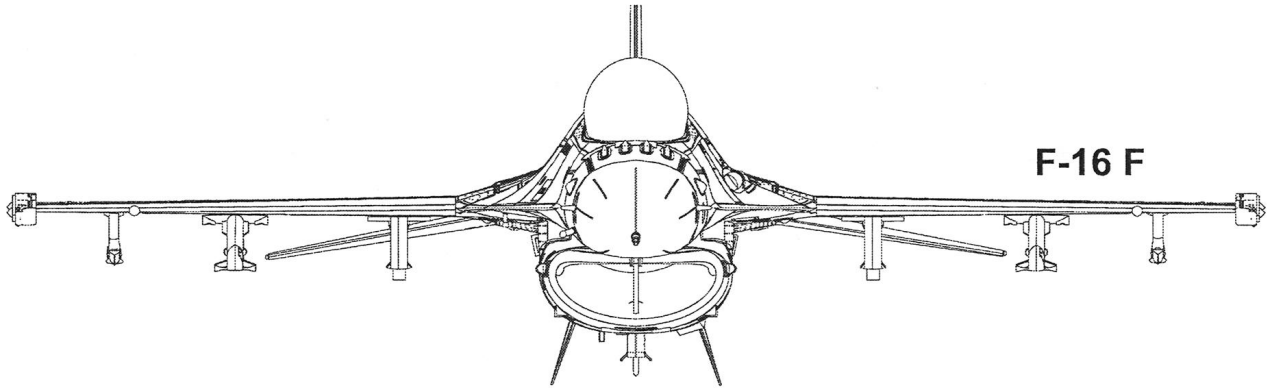

Station No. Weapons	9	8	7	6	5R	5	5L	4	3	2	1
LAU-114 (W/AIM-9M only)	●	●	●						●	●	●
LAU-129	●	●	●						●	●	●
AIM-9M	●	●	●						●	●	●
AIM-9X (W/LAU-129 only)	●	●								●	●
AIM-120B (W/LAU-129 only)	●	●	●						●	●	●
MK.82			●						●		
MK.82 (W/TER)			● ●						● ●		
GBU-12			●						●		
GBU-12 (W/TER)			● ●						● ●		
GBU-31			●						●		
GBU-87			●						●		
GBU-87 (W/TER)			● ●						● ●		
GBU-38			●						●		
GBU-38 (W/TER)			● ●						● ●		
GBU-24			●						●		
AGM-65			●						●		
370gal. Fuel tank				●				●			
300gal. Fuel tank						●					
AN/AAQ-32							●				

1/48 SCALE AIRCRAFT SERIES: F - 16F

 F-16F UNITED ARAB EMIRATES AIR FORCE

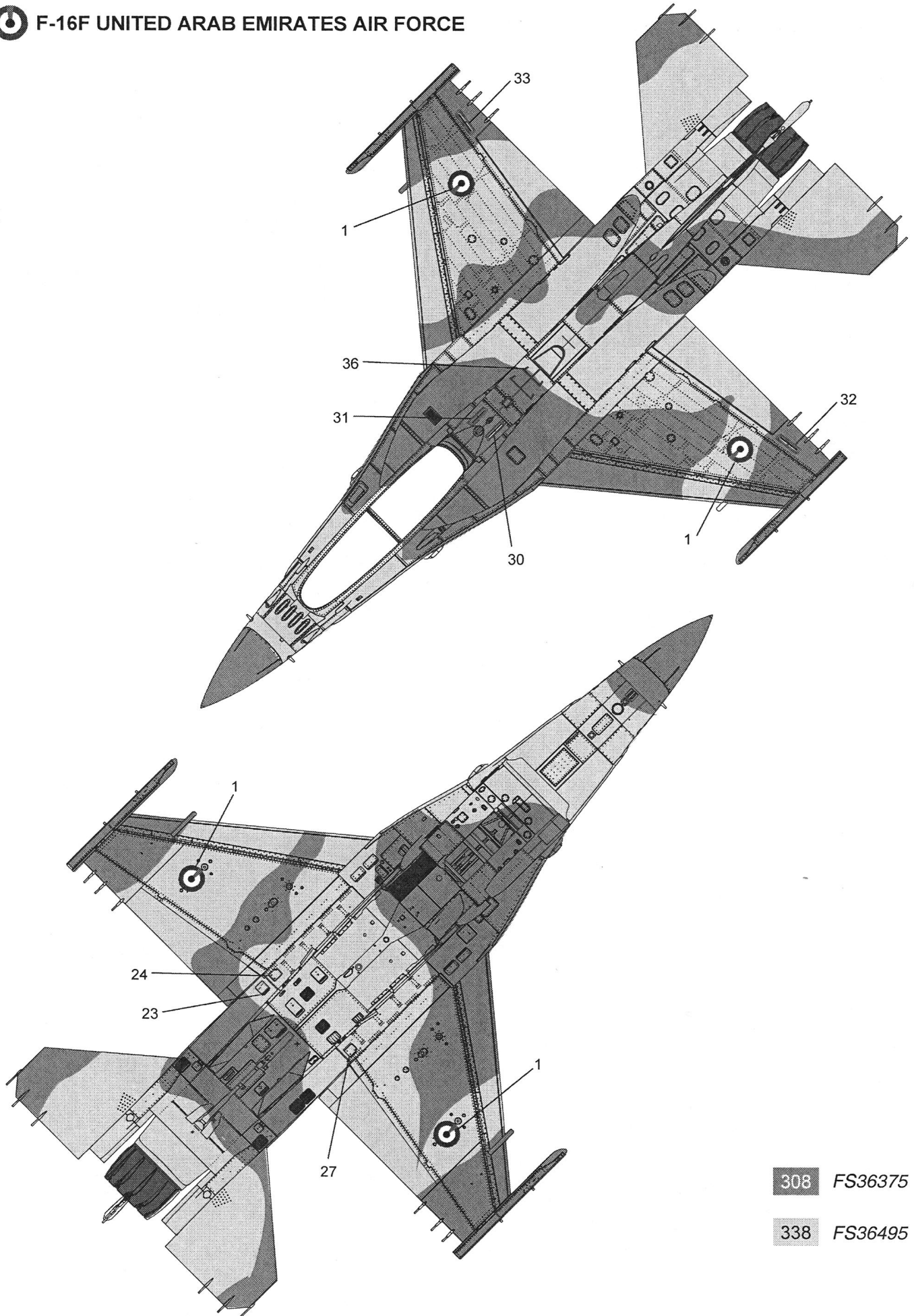

308 FS36375

338 FS36495

1/48 SCALE AIRCRAFT SERIES: F - 16F

F-16F UNITED ARAB EMIRATES AIR FORCE

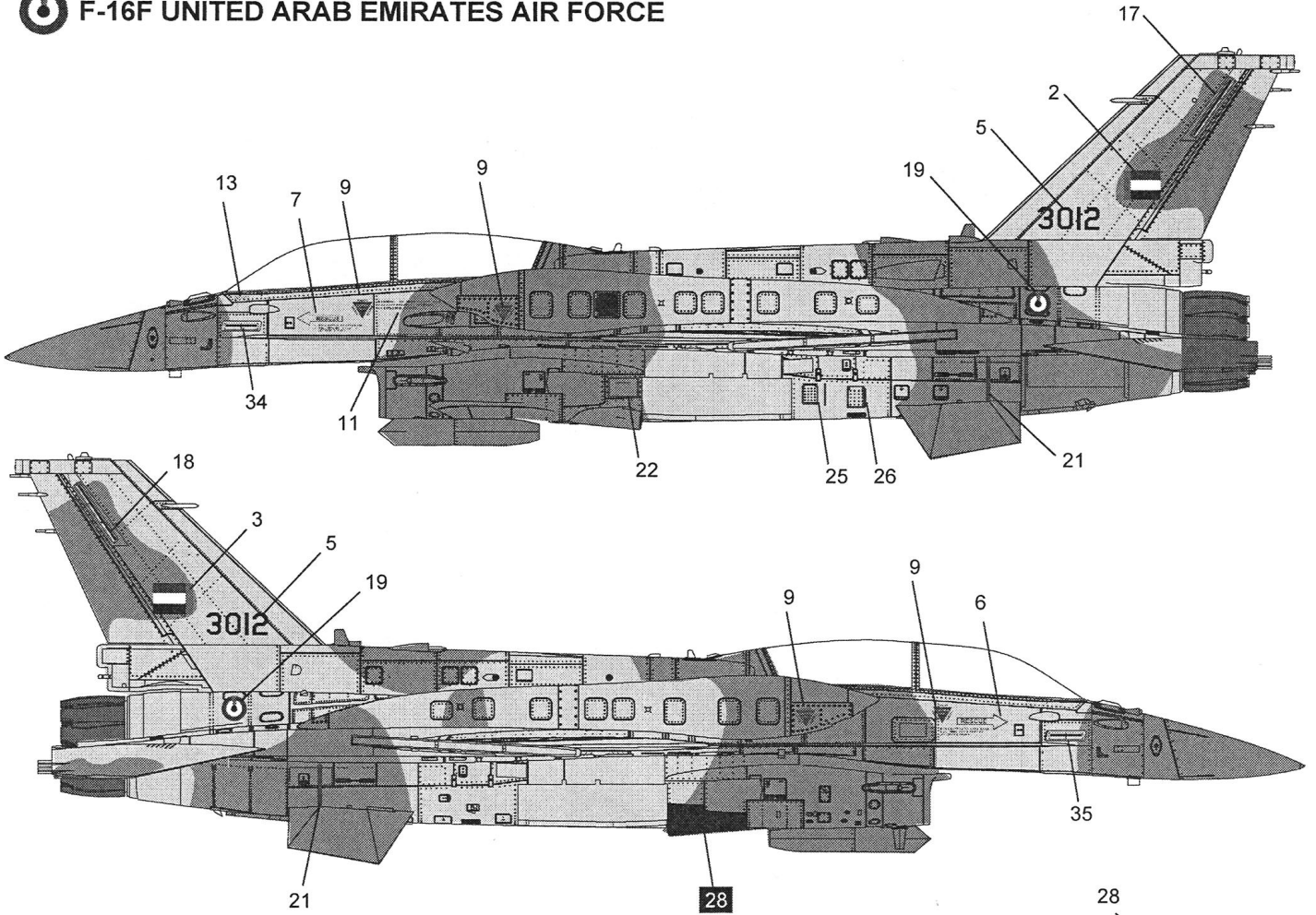

308 FS36375

338 FS36495

