

DOUGLAS

A-20J "HAVOC"



Stock No. 8895

BEFORE YOU BEGIN!

Read the Supplemental Instruction Sheet that accompanies this one Before You Begin! It contains modeling tips, paint requirements, and other important information you should know before assembling your model kit.

1A

11: CONTROL PANEL (Right)

OVERALL: *Interior Green*
BOXES (Shaded Areas): *Black*
ALL DIALS: *White*

DETAIL

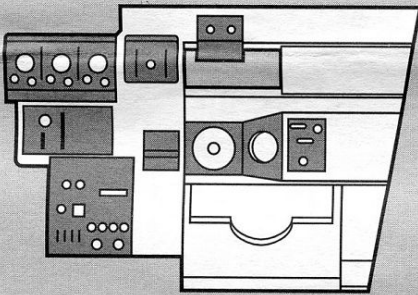

1B

10: CONTROL PANEL (Left)

OVERALL: *Interior Green*
LEVERS / DETAIL (Shaded Areas): *Black*
ALL KNOBS: *White*

DETAIL

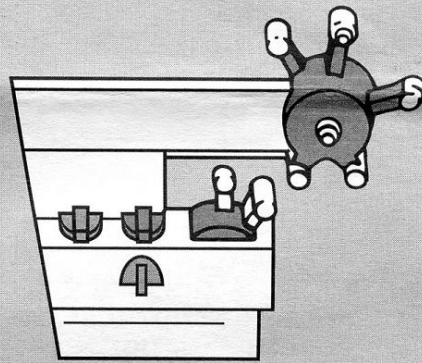

1C

7
CONTROL COLUMN
Interior Green

8
YOLK
Black

9
SEAT
Interior Green

11
CONTROL
PANEL
(Right)

5
COCKPIT FLOOR
Interior Green

6
INSTRUMENT PANEL
Black
INSTRUMENTS: *White*

10
CONTROL
PANEL

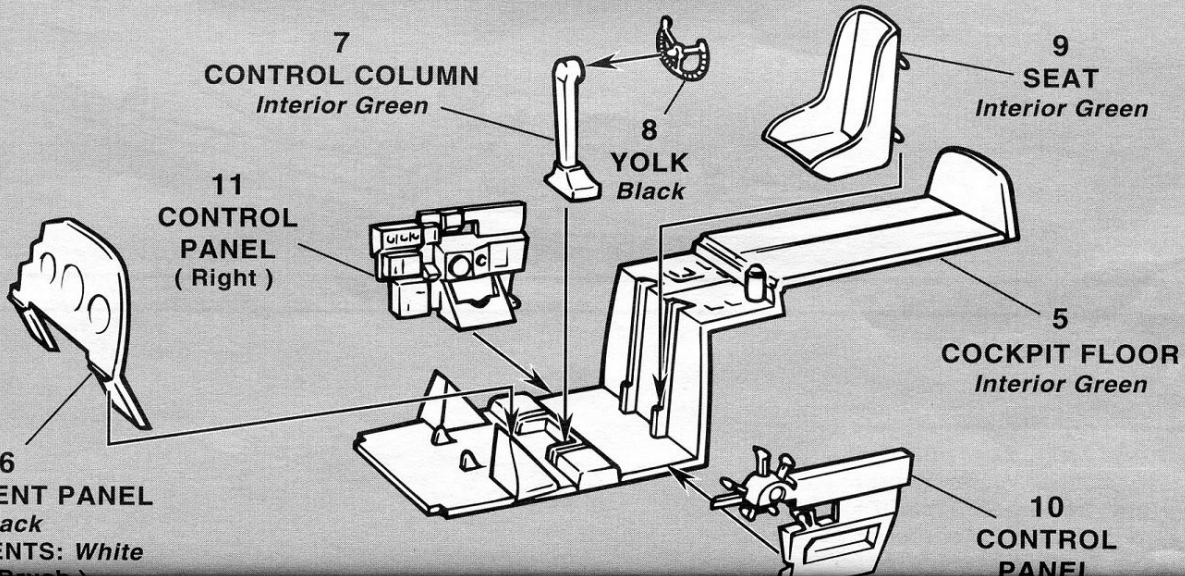

43
**NOSE GEAR
 ACTUATOR**
Neutral Gray
 NOTE: Install First.

35
RETRACTOR STRUT
Neutral Gray

34
**NOSE GEAR
 SCISSORS**
Neutral Gray

33
NOSE GEAR STRUT
Neutral Gray

15A GEAR DOWN

NOTE: After assembly mask the WINDSCREEN, CANOPY GLASS, REAR MACHINE GUN, BOMB BAY opening, both LANDING GEAR openings and the front opening of both ENGINE COWLS and paint assembly as a unit.

15B

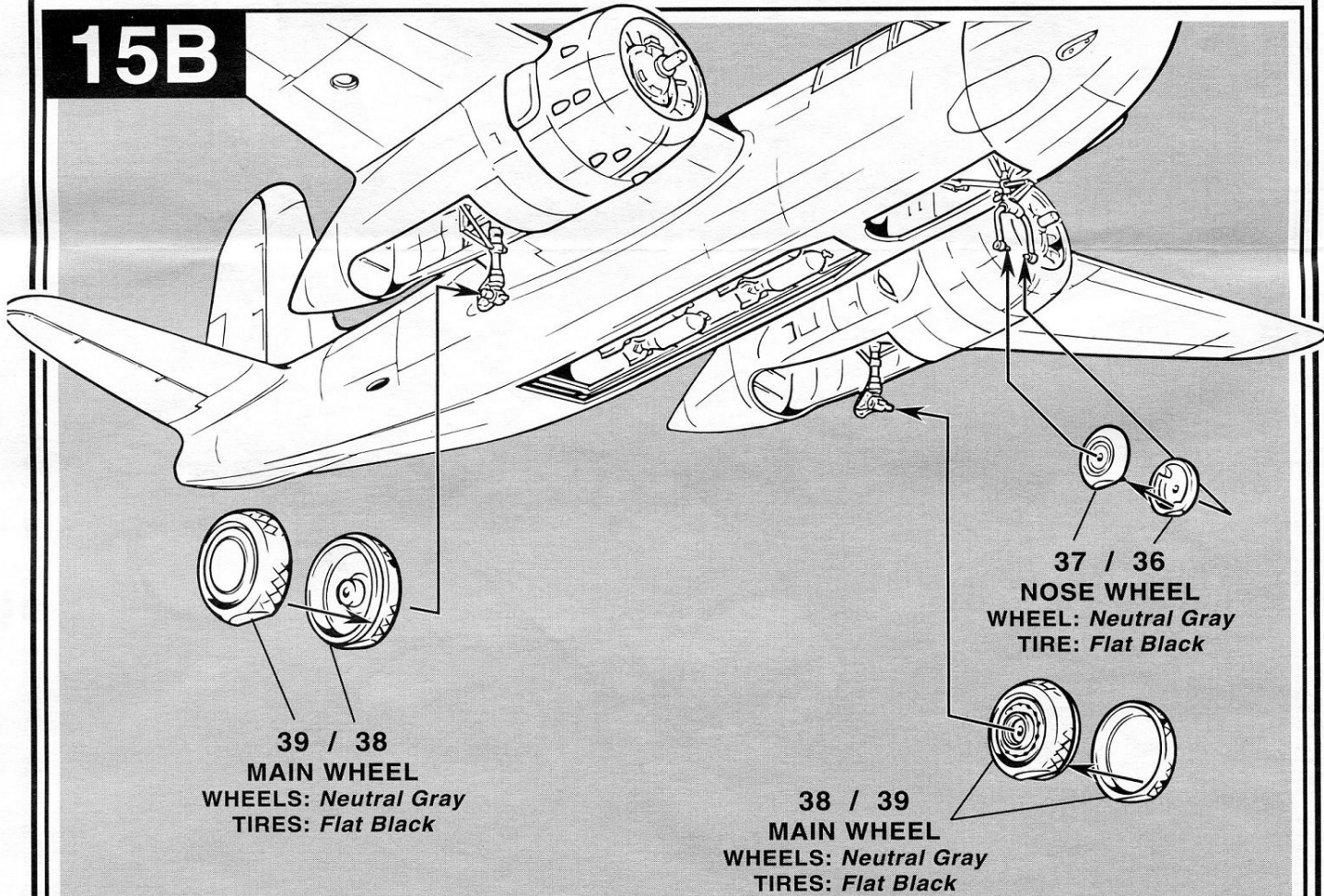

37 / 36
NOSE WHEEL
 WHEEL: *Neutral Gray*
 TIRE: *Flat Black*

39 / 38
MAIN WHEEL
 WHEELS: *Neutral Gray*
 TIRES: *Flat Black*

38 / 39
MAIN WHEEL
 WHEELS: *Neutral Gray*
 TIRES: *Flat Black*

NOTE: While cement is still wet place the model on a flat surface to align the flattened areas of the tires.

15C

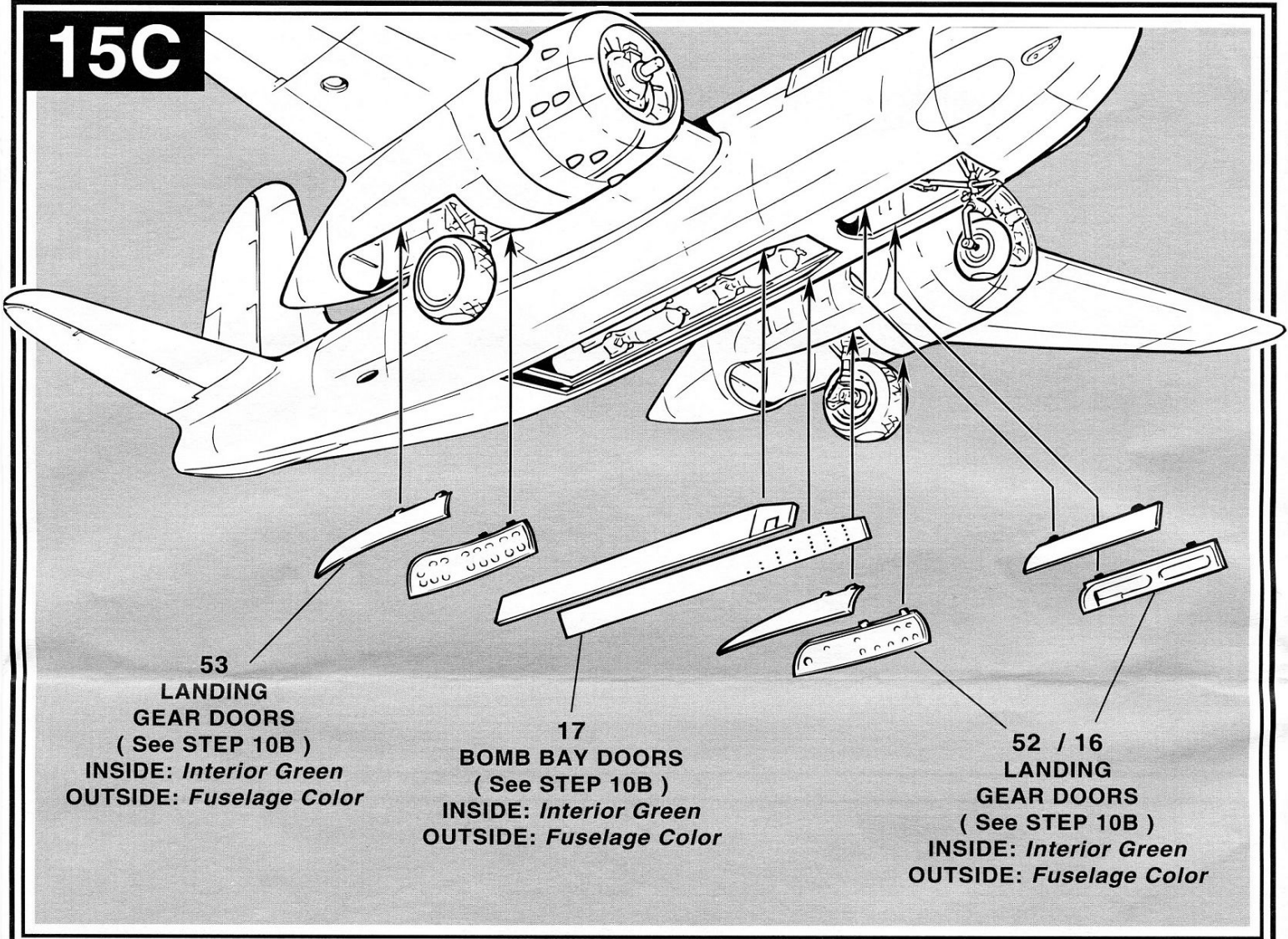

16

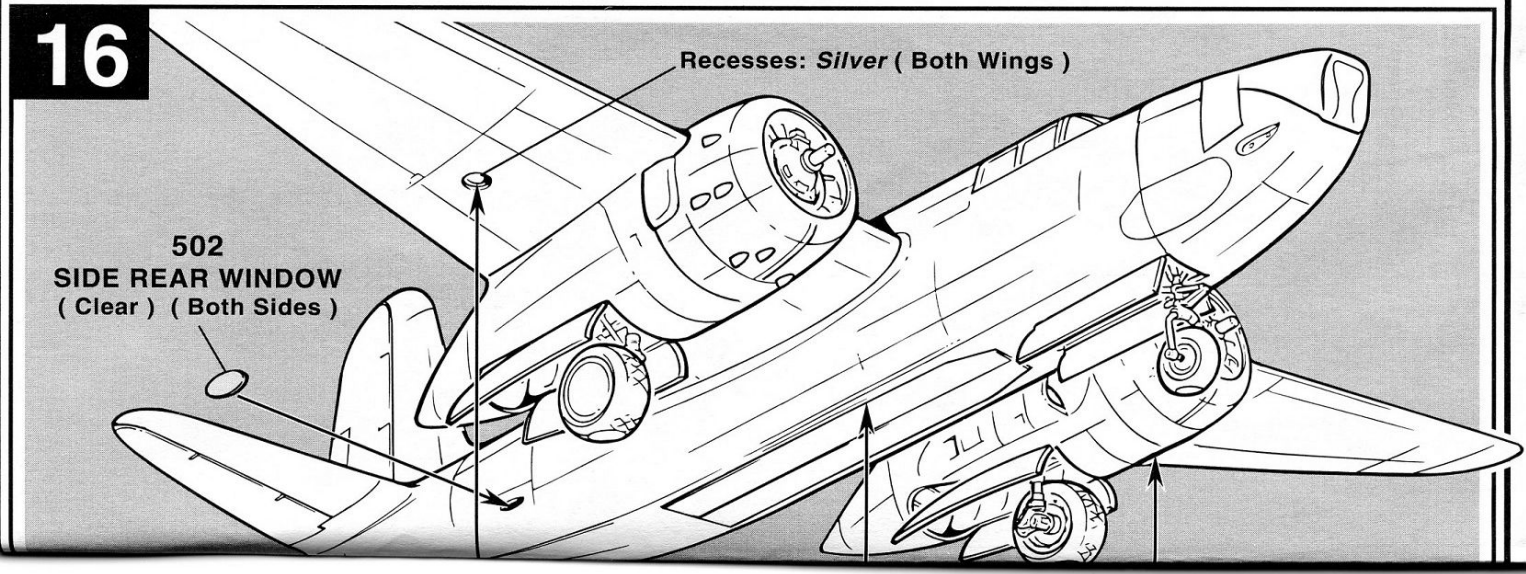

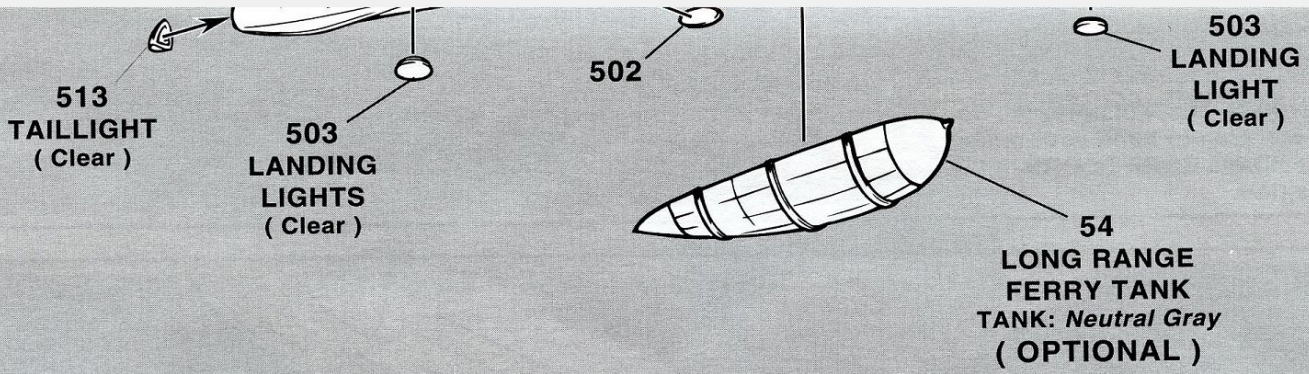

17

NOTE: Paint parts ANTENNA MAST(14) and RADIO DIRECTION LOOP(15) to match the aircraft.

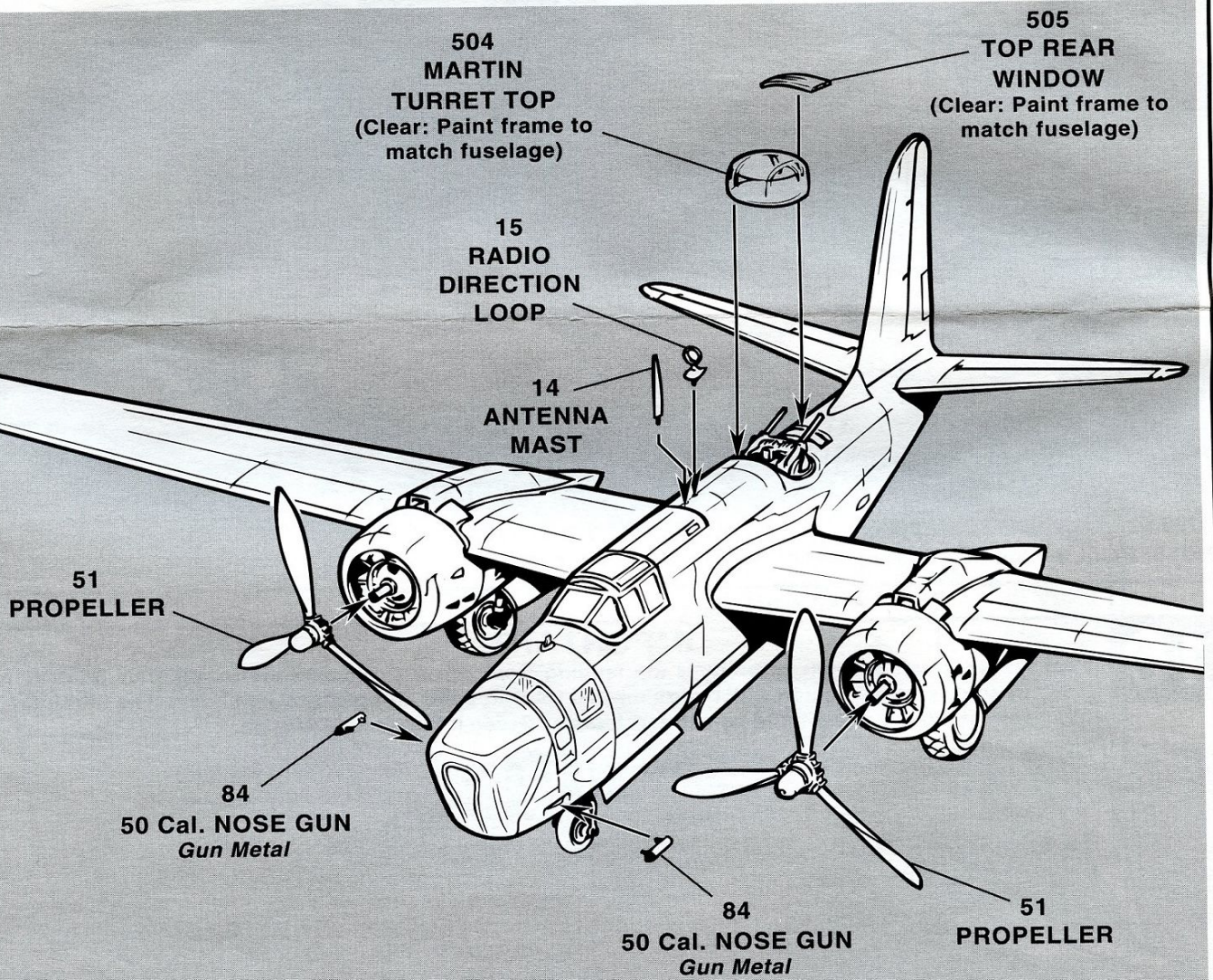

1D

NOTE: The bottom edge of the NOSE GEAR WELL should align with the bottom edge of the NOSE BULKHEAD.

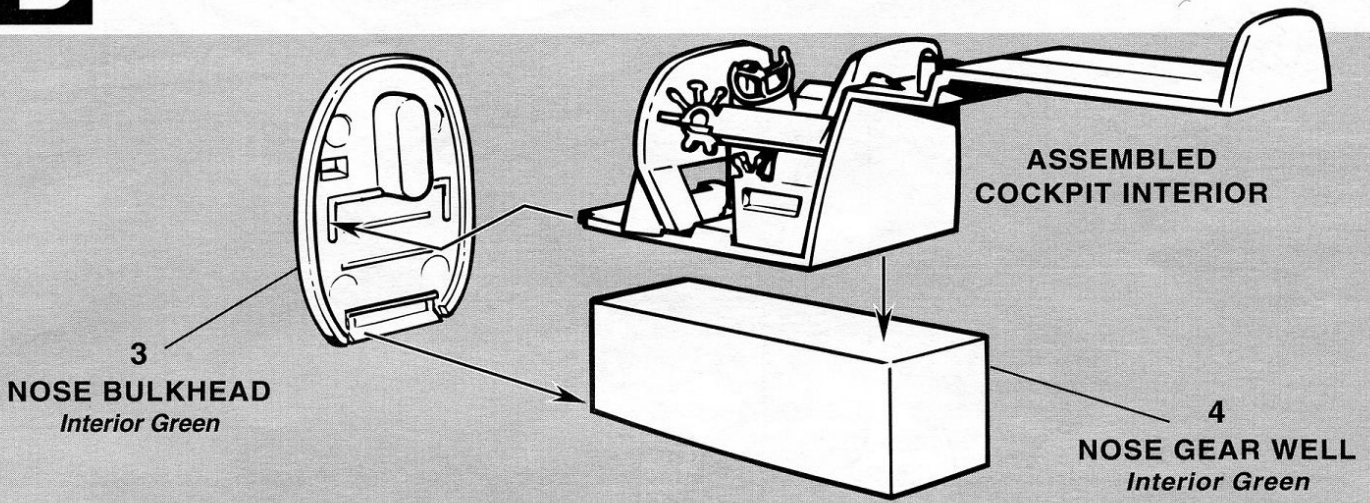

1E

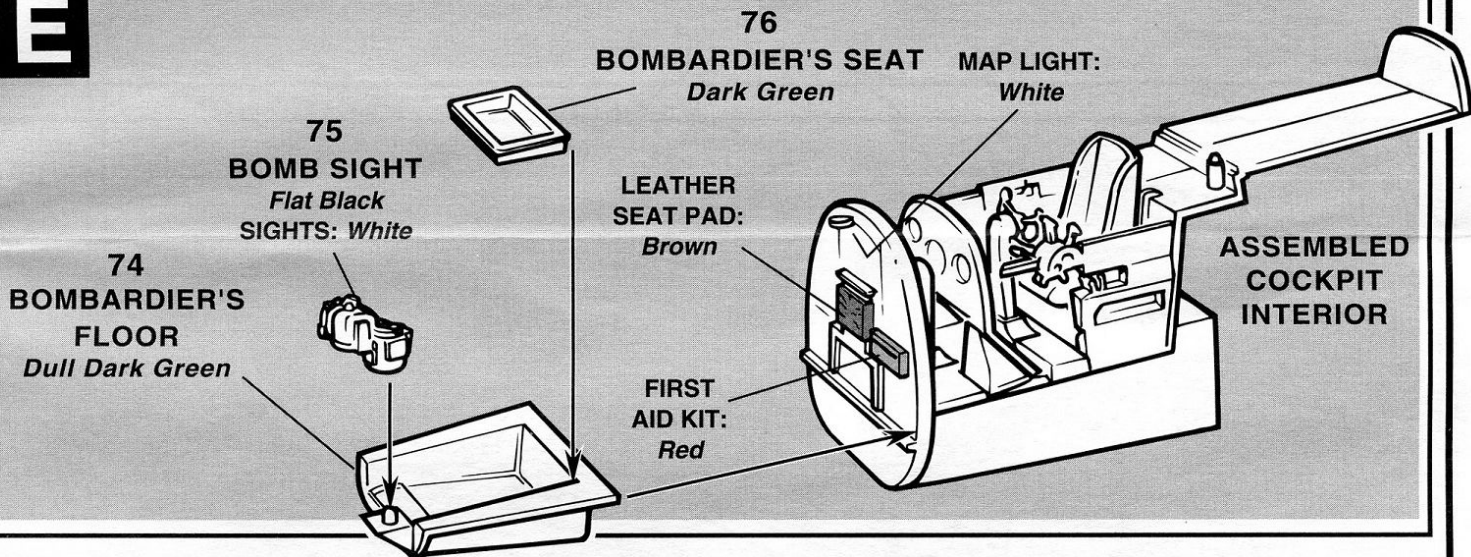

2

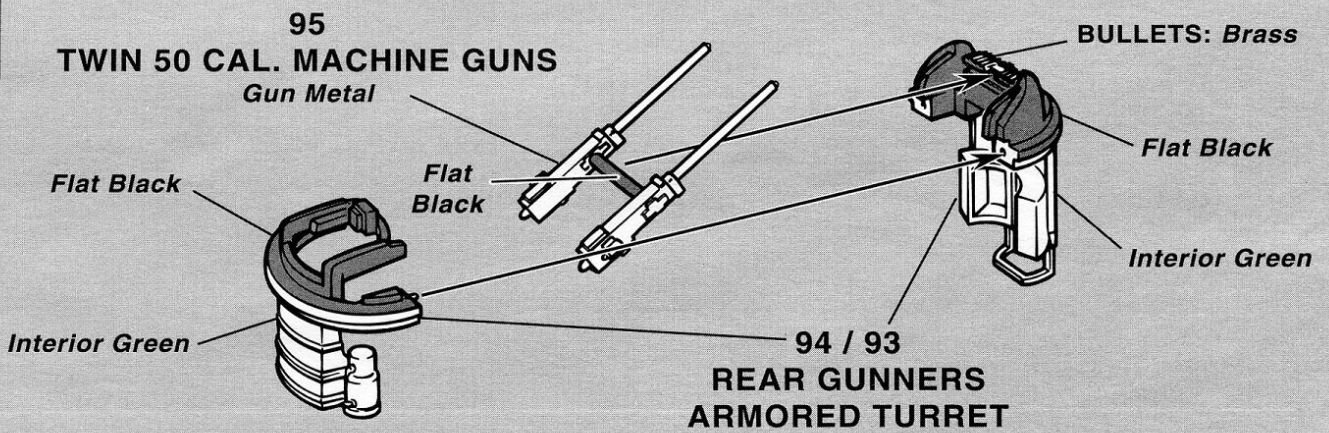

3

78
UPPER BOMB HALVES
Dark Olive Drab

NOTE: BOMBS are optional. Do not use if you plan to build your model with the BOMB BAY DOORS closed (STEP 16).

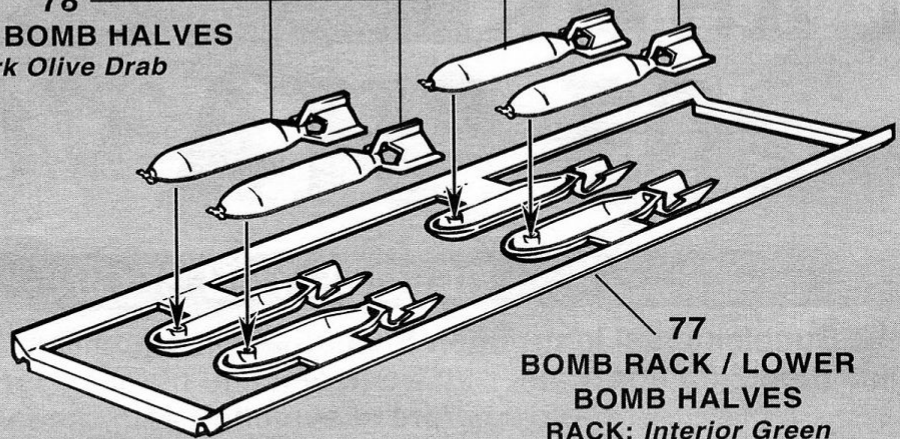

77
BOMB RACK / LOWER BOMB HALVES
 RACK: *Interior Green*
 BOMBS: *Dark Olive Drab*

4

NOTE: Paint the inside of both FUSELAGE HALVES *Interior Green*. After assembly, use tape or rubber bands to hold the fuselage together while the cement is allowed to dry thoroughly.

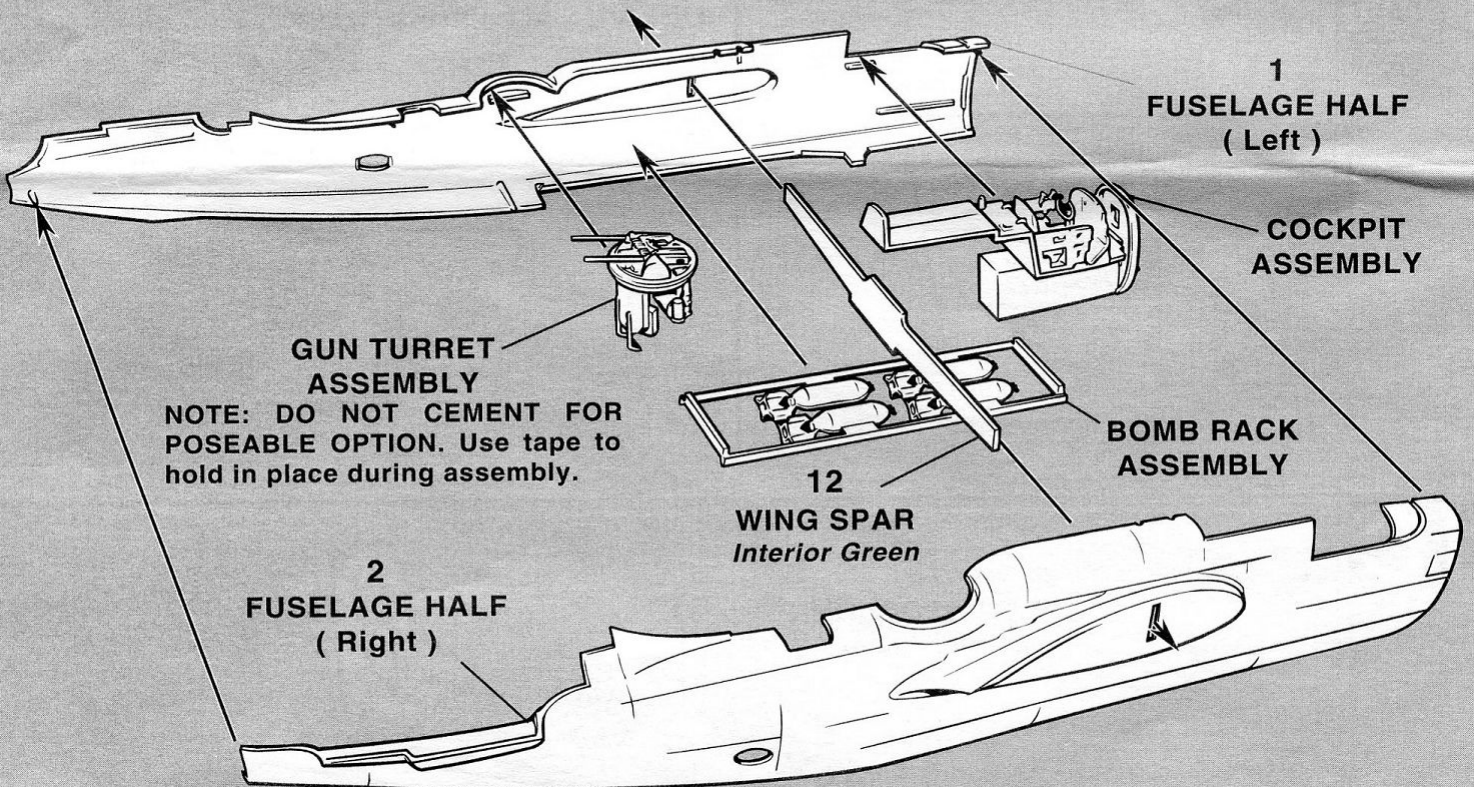

GUN TURRET ASSEMBLY
NOTE: DO NOT CEMENT FOR POSEABLE OPTION. Use tape to hold in place during assembly.

1
FUSELAGE HALF (Left)

COCKPIT ASSEMBLY

BOMB RACK ASSEMBLY

12
WING SPAR
Interior Green

2
FUSELAGE HALF (Right)

5

IMPORTANT: For proper balance we recommend adding as much weight as possible (Modelers

CANOPY
 13
Fuselage Color & 501 (Clear)

BOTTOM:
Interior Green

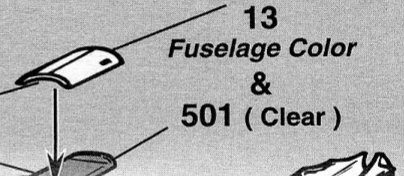

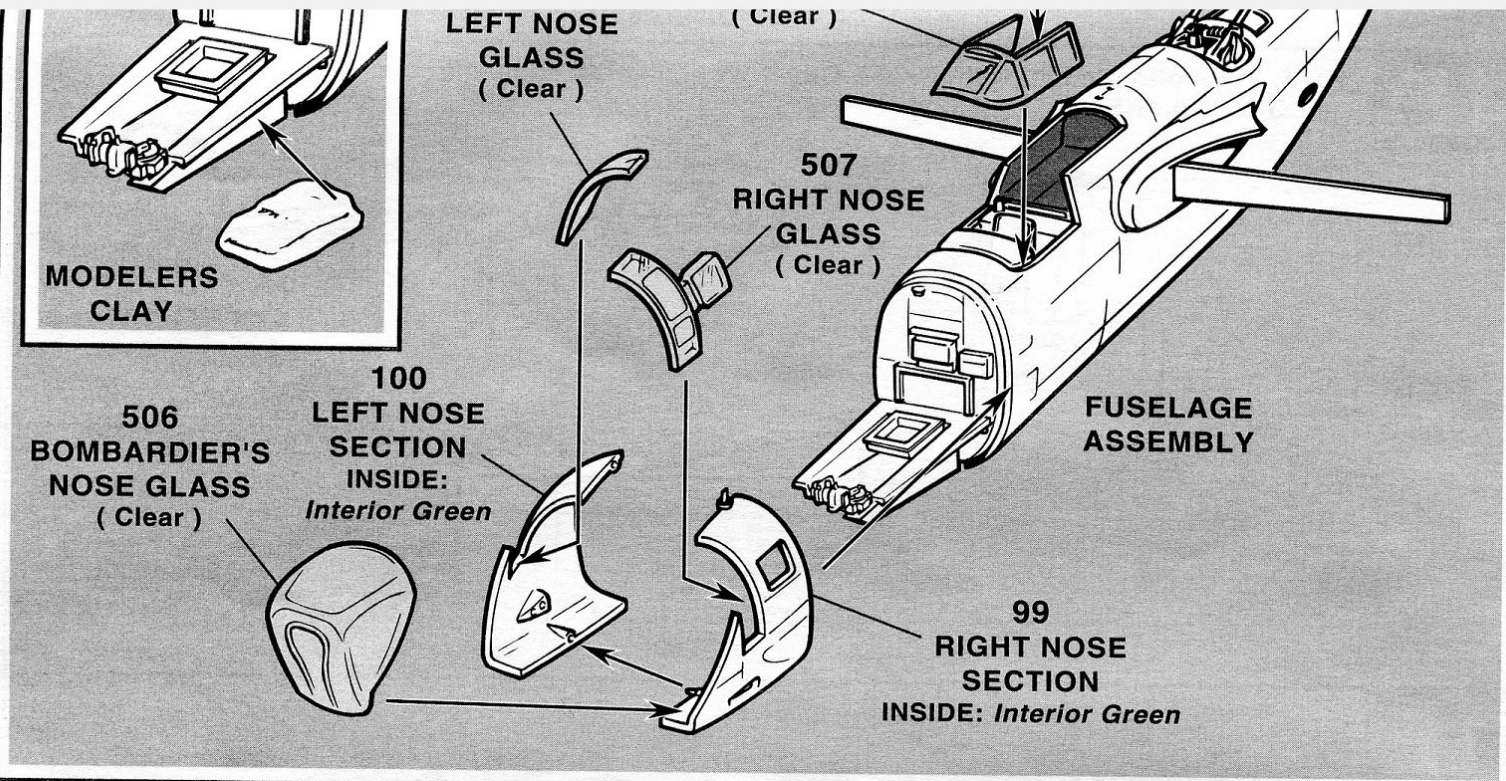

6

VERTICAL STABILIZER
21 / 22

HORIZONTAL STABILIZER
18 / 20 / 19

FUSELAGE ASSEMBLY

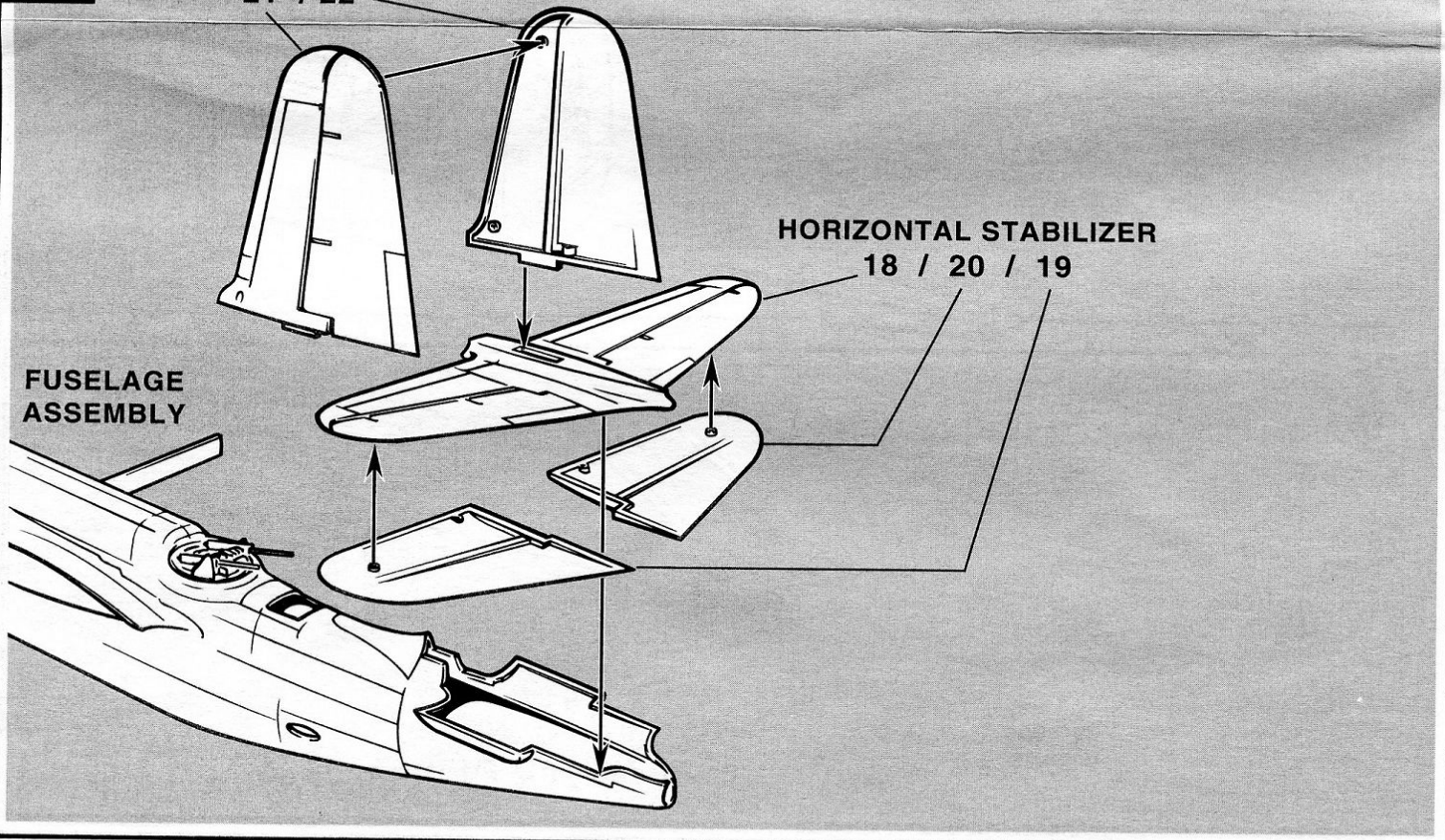

7

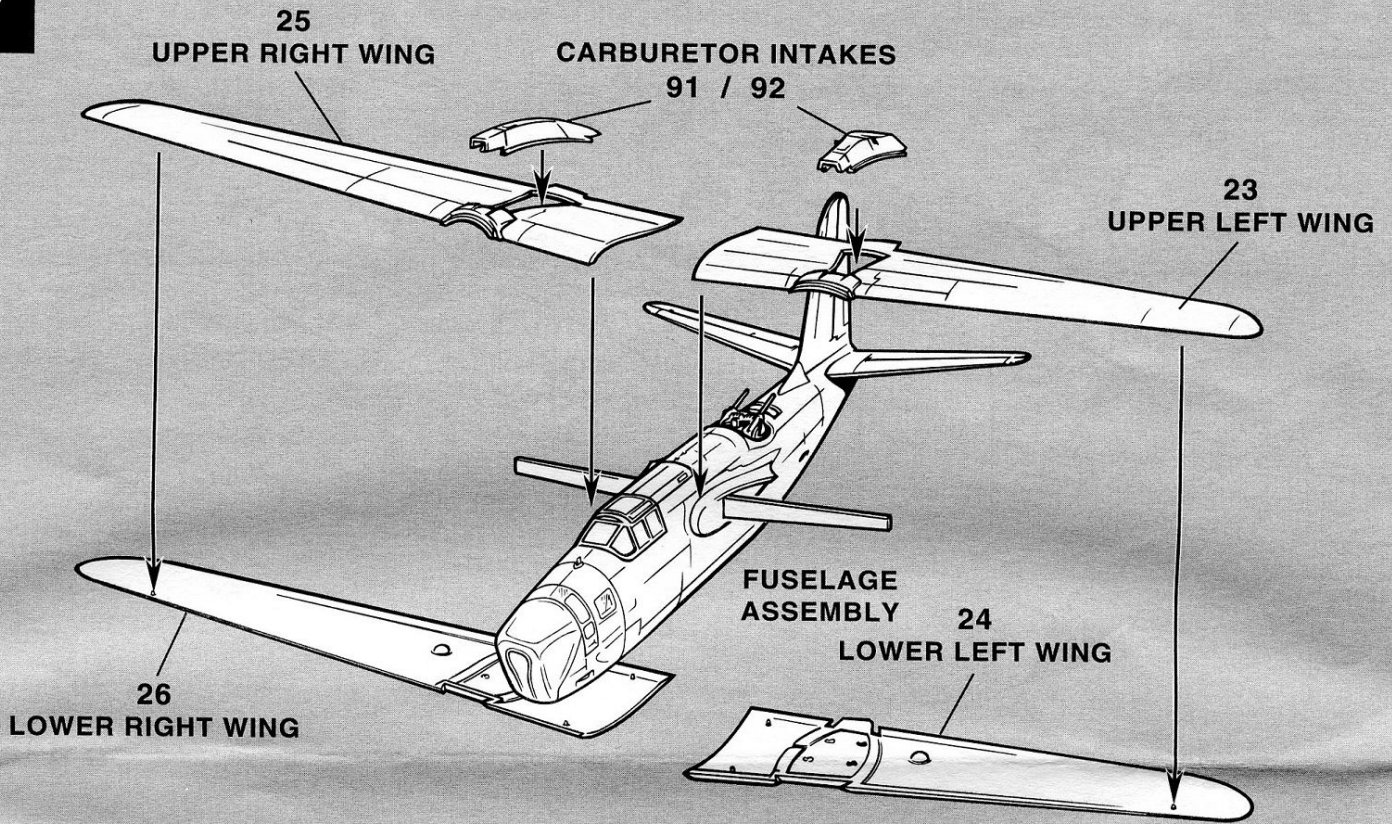

8

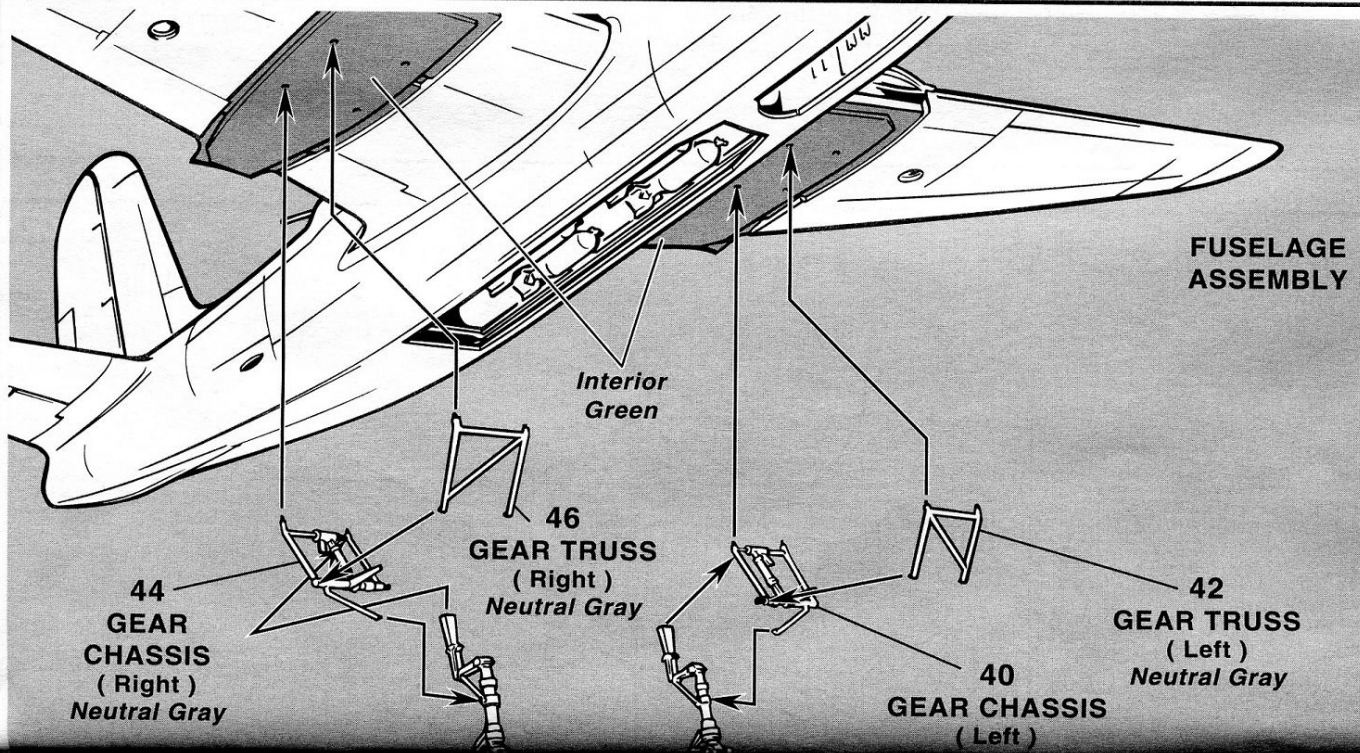

41 (Right) / 45 (Left)
LANDING GEAR STRUTS

Neutral Gray
Paint BRAKE LINES: Black

NOTE: LANDING GEAR is optional. Do not use if you plan to build your model with the LANDING GEAR DOORS in the closed position.

9

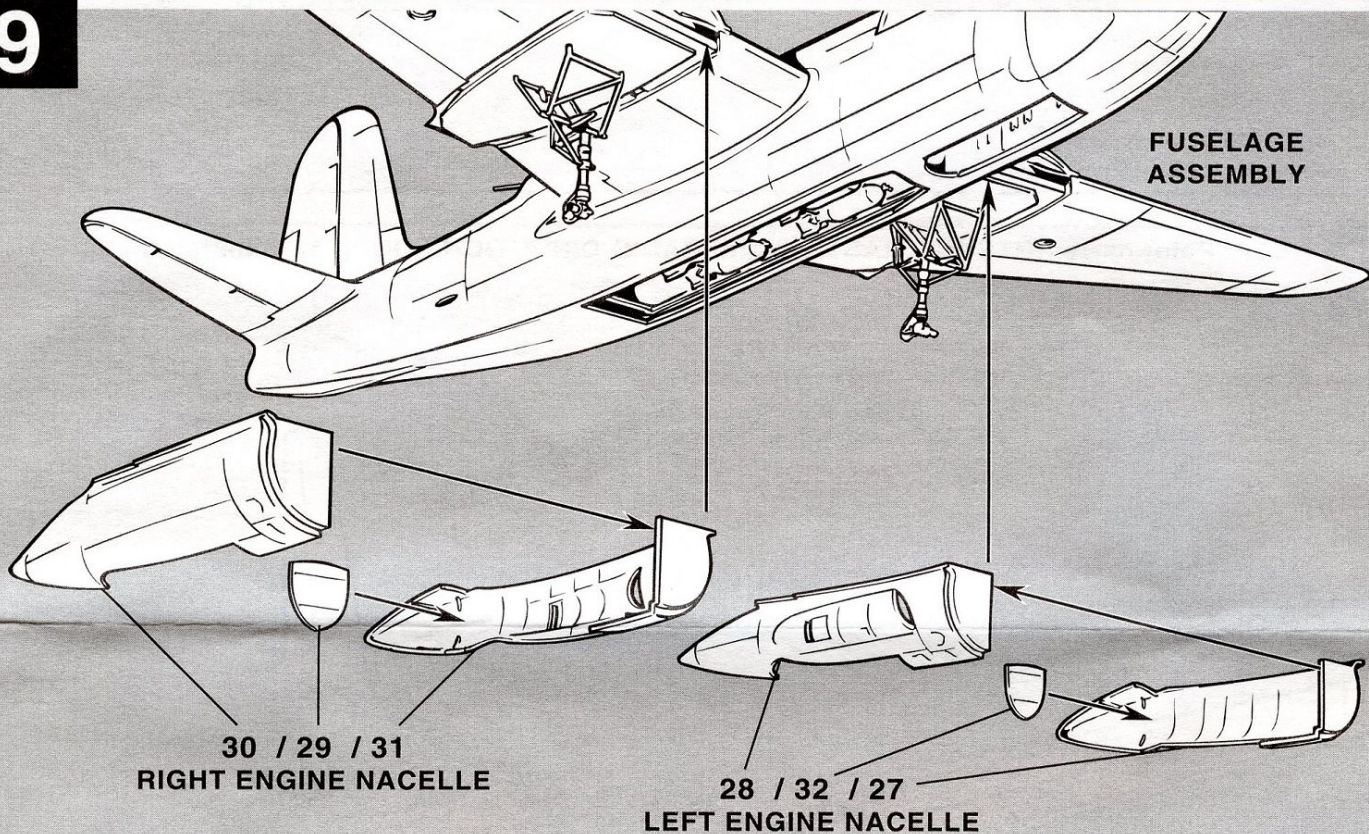

NOTE: Paint the inside of both ENGINE NACELLES *Interior Green*

10

IMPORTANT

This kit can be built with either the landing Gear Up or Down and the BOMB BAY DOORS open or closed. Decide which version you want to build and proceed as shown. The interior side of these parts should be painted *Interior Green* if the doors are open.

A

NOTE: For GEAR UP display, carefully cut the 'TABS' from the sides of the LANDING GEAR DOORS.



B

NOTE: For GEAR DOWN display, carefully cut the LANDING GEAR DOORS in half.

If you plan to use the LONG RANGE FUEL CELL (STEP 16) DO NOT cut the BOMB BAY DOORS. They will need to remain in the closed position.

For BOMB BAY DOORS OPEN cut the BOMB BAY DOORS OPEN in half.

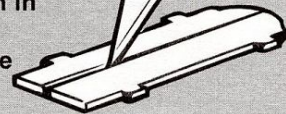

11

NOTE: Paint the inside of LEFT ENGINE COWL *Interior Green*.
For ENGINE BANKS painting see detail drawing below

(Left)

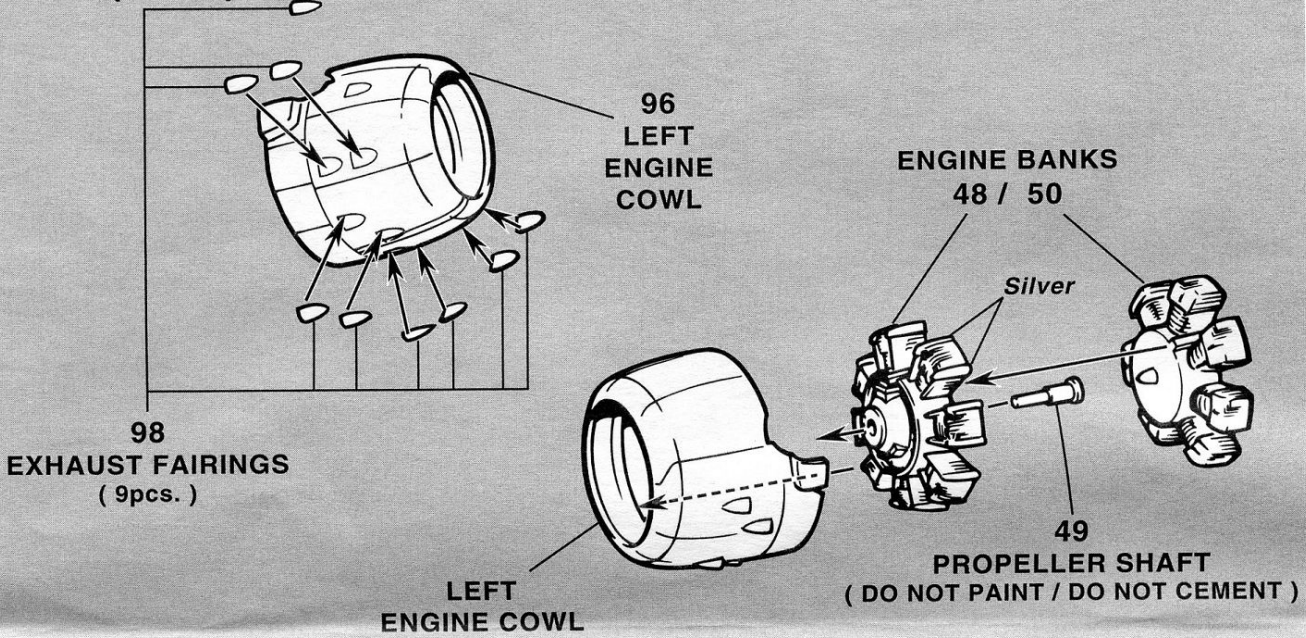

12

NOTE: Paint the inside of LEFT ENGINE COWL *Interior Green*.
For ENGINE BANKS painting see detail drawing below

(Right)

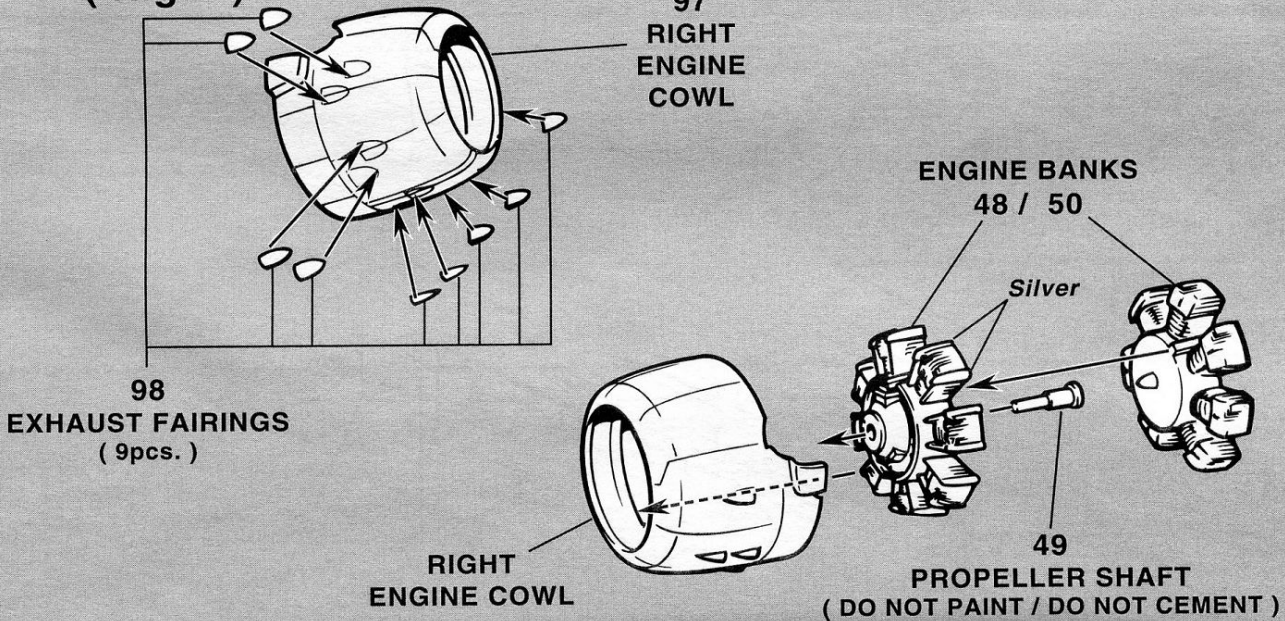

DETAIL

NOTE: Align ENGINES into ENGINE COWLS as shown.

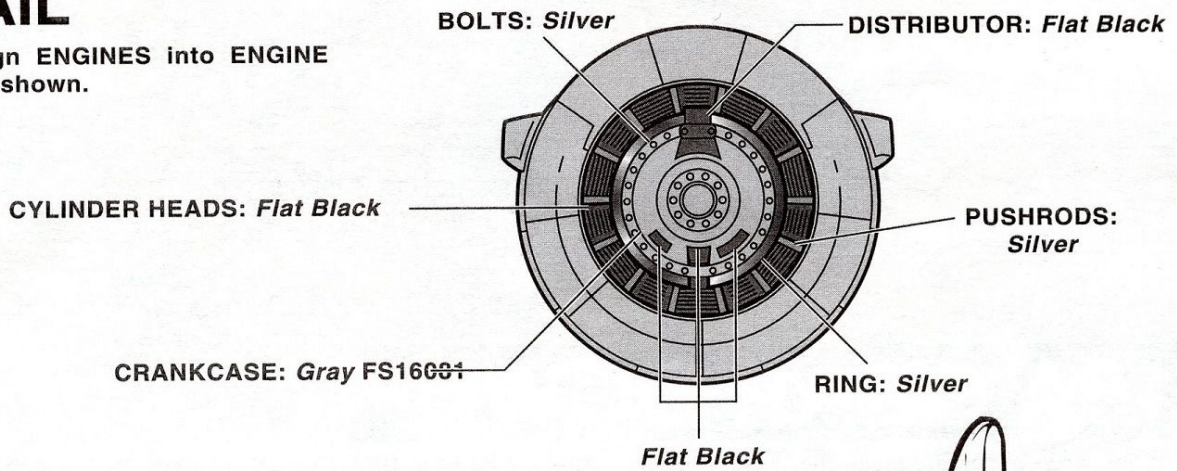

13

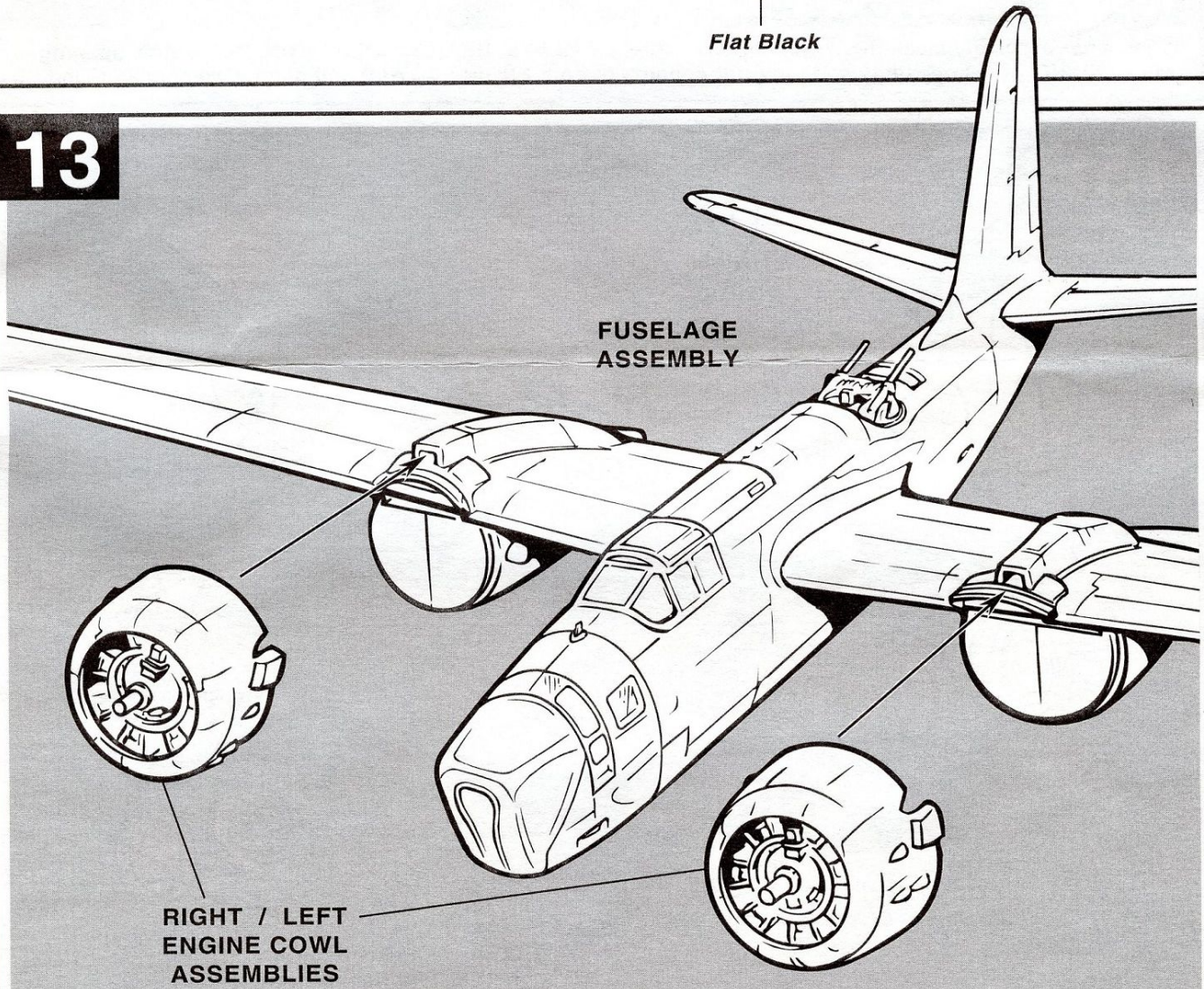

A-20J HAVOC

Form No. 099 - 8895

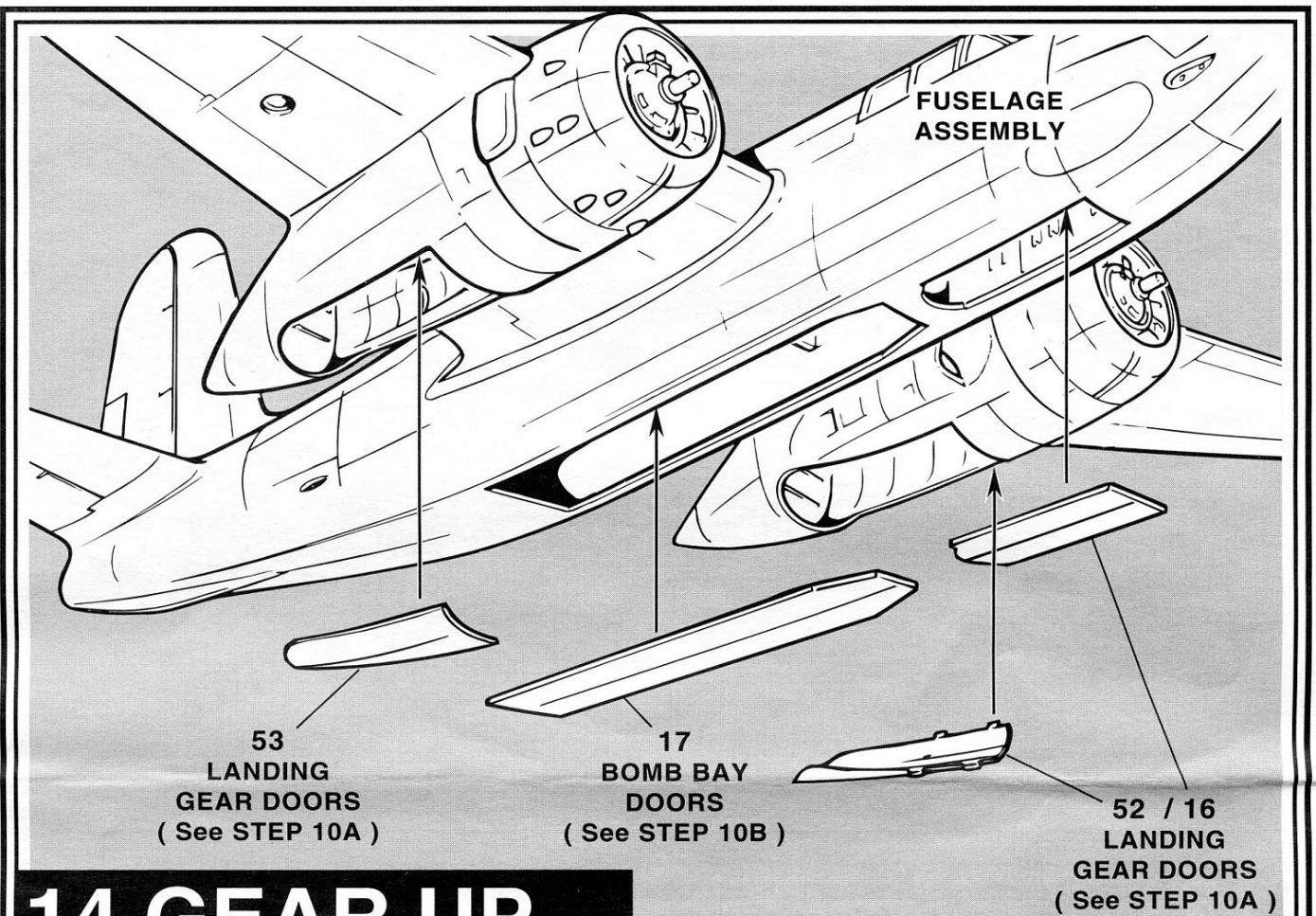

14 GEAR UP

NOTE: Mask the WINDSCREEN, CANOPY GLASS, GUN TURRET ASSEMBLY and the front opening of both ENGINE COWLS and paint assembly as a unit.

