

Pz.Kpfw.IV Ausf.J Last

● READY TO ASSEMBLE PRECISION MODEL KIT ● MODELING SKILLS HELPFUL IF UNDER 14 YEARS OF AGE ● MODEL MAY VARY FROM IMAGE ON BOX ● CEMENT AND PAINT NOT INCLUDED

ドイツIV号戦車J最後期型

2
in
one

1
2
Workable track links
連結組立可動式履帯
link & Length style tracks
部分的に結合された履帯



1/35
SCALE
BT-008

JASDN 2019

Border

History | 历史介绍

Panzer IV J Last

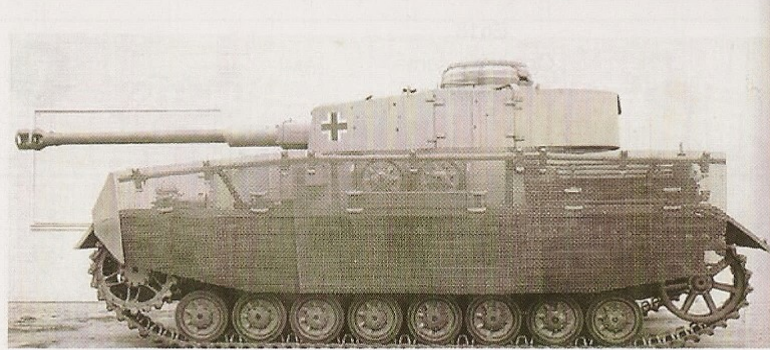
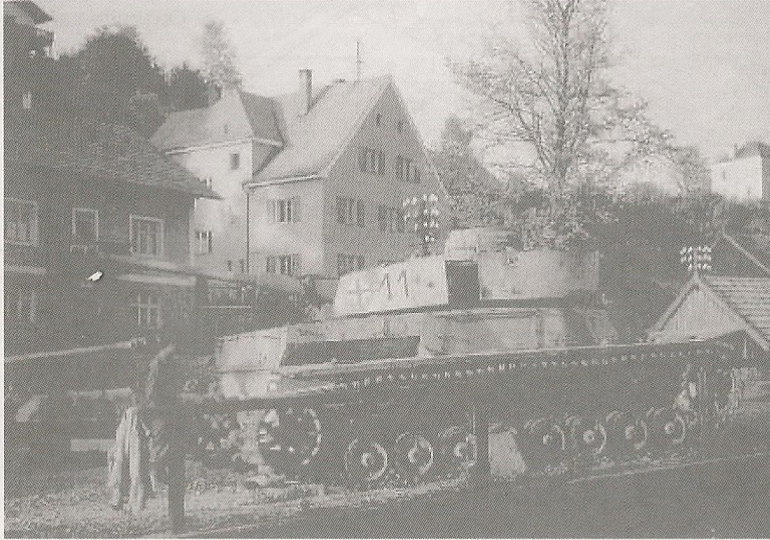

In June 1944, Panzer IV J, the last mass-produced model of Panzer IV, started production. The J-type is similar to the H-type, with some modifications to the exhaust and suspension system for ease of manufacture. By March 1945, the Nibelungenwerk had produced a total of 1,758 Panzer IV type J. But because the German war losses were so great, the J-type greatly simplified its production process to increase production speed. The generator used to assist the rotating turret was eliminated. All Panzer IV turrets were electrically driven, while the J-type had to be manually rotated, leaving space for an auxiliary fuel tank with a capacity of 200 litres, increasing its maximum range to 320km. In late 1944, German armored vehicles no longer used Zimmerit on their tanks, and the J-type was also removed. The last model adopted casting idler and steel supporting wheels, reducing the supporting wheels to 3, and the 5mm side skirt of the J-type was changed to iron mesh system. They also removed the gun and observation ports from the turrets and simplified the engine's radiator. Panzer IV H and J are powerful weapons in experienced soldiers. In addition to the formal improvements, the Panzer IV also implemented continuous improvements based on feedback from the front line and even crew modifications.

1944年6月，IV号坦克J型开始进入制造，这是IV号坦克最后一种量产型号。J型和H型差不多，在排气装置以及悬挂系统上做了一些改动以易于制造。到1945年3月，尼伯伦根工厂一共生产了1758辆IV号坦克J型。但由于德军战损非常多，J型大幅简化其生产过程来提高生产速度。用来协助旋转炮塔的发电机被取消，所有的IV号坦克炮塔都是采用电驱动转动，而J型则是只能采用手动式旋转，留下来的空位用来作辅助燃料槽，该槽容量达200升，故其最大行程增至320千米。而1944年后期，德军的装甲车的坦克不再使用防磁装甲，IV号J型也同样取消了防磁装甲。晚期型的J型采用了铸造诱导轮以及钢质托带轮，将托带轮减少为3个，同时J型的5mm侧裙改为铁网制。厂方还取消了炮塔上的手枪射击口及观察口，同时简化引擎的散热器。IV号坦克H型和J型在有经验的坦克手手里都是极具威力的武器。除了正式改进，IV号坦克还根据前线反馈的信息实施的不间断改进甚至乘员自己的改造。

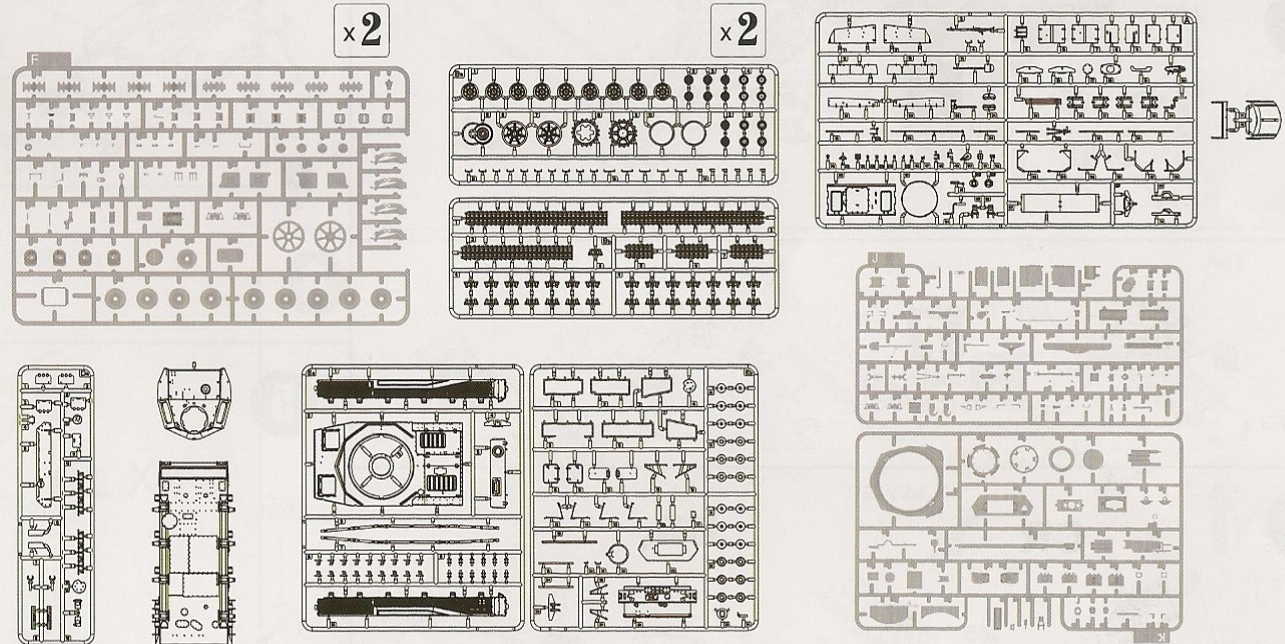

Assembly of Special Optional Parts

特殊的搭载物品组装

(A) x2

(B) x2

(C) x2

(D) x10

Optional Parts:
Additional Track from T34 Tank
可选择搭载物：
来自T34坦克的备用履带

1

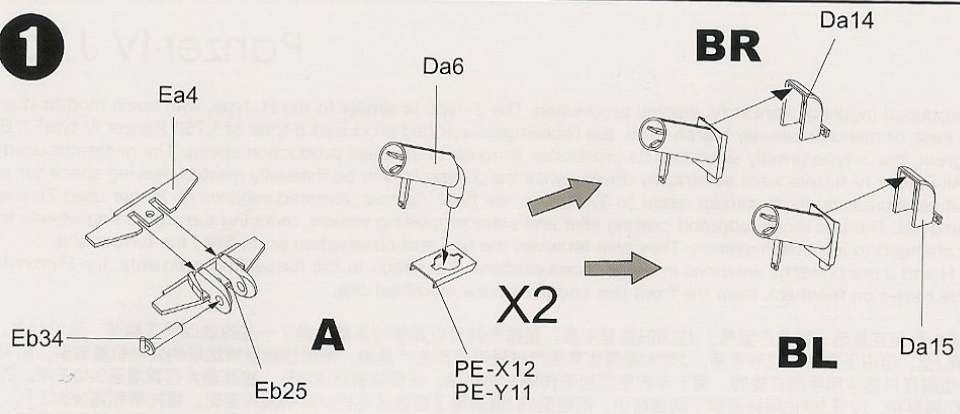

2

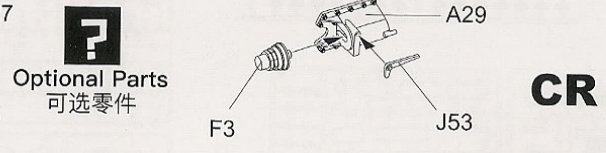
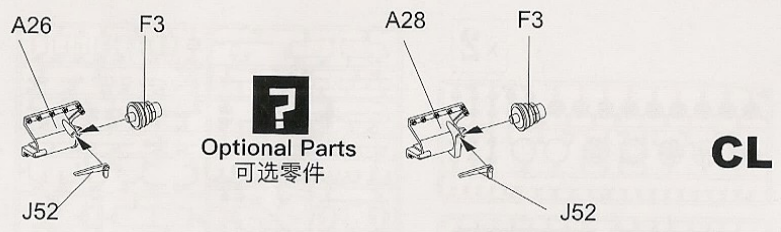

3

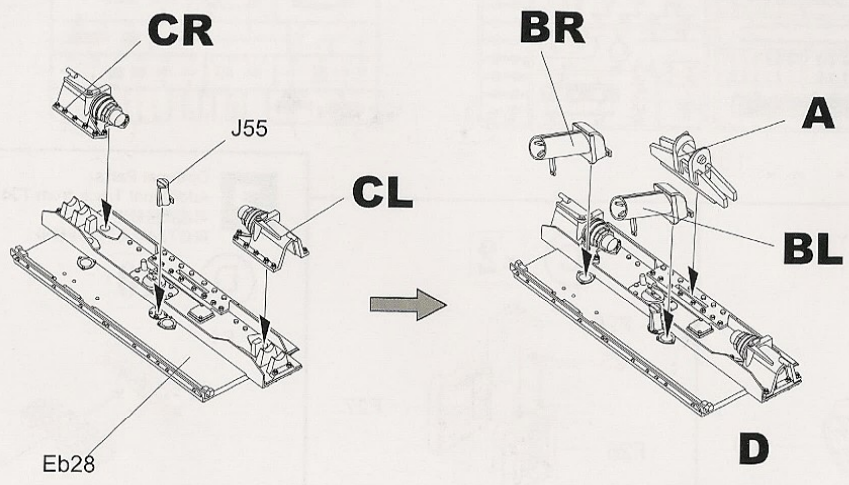

4

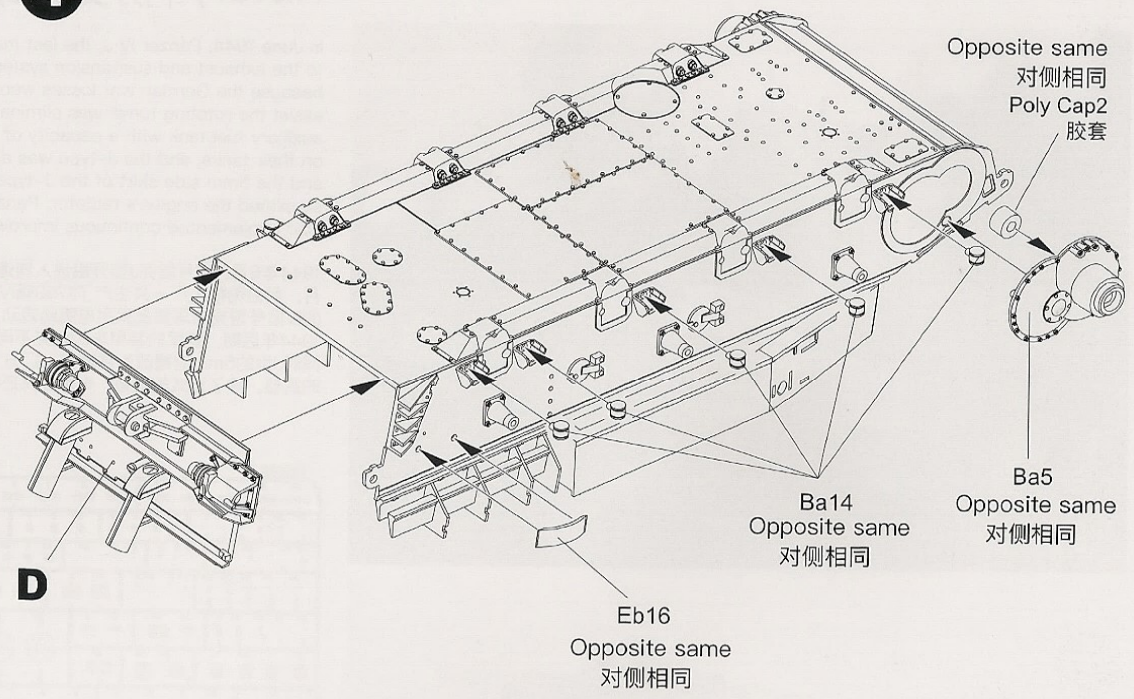

5

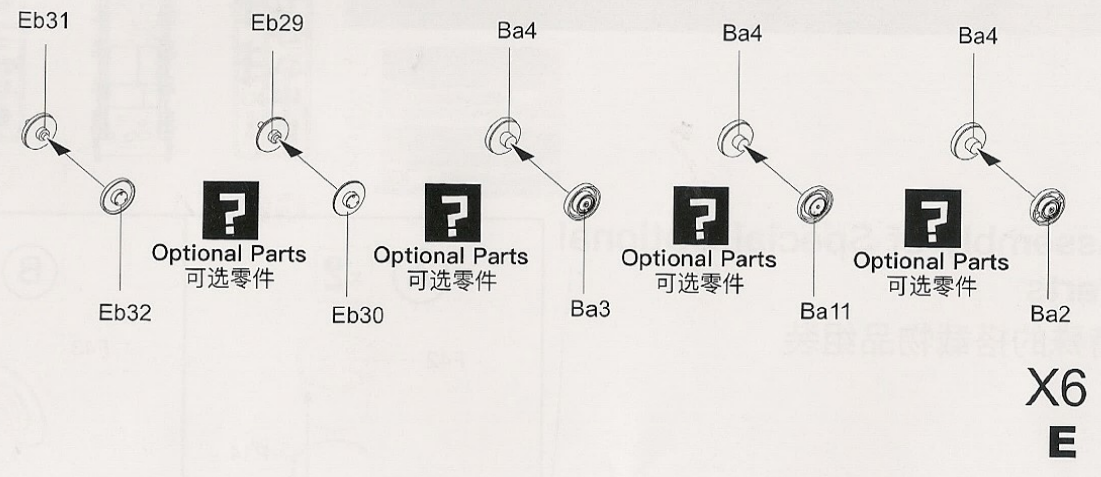

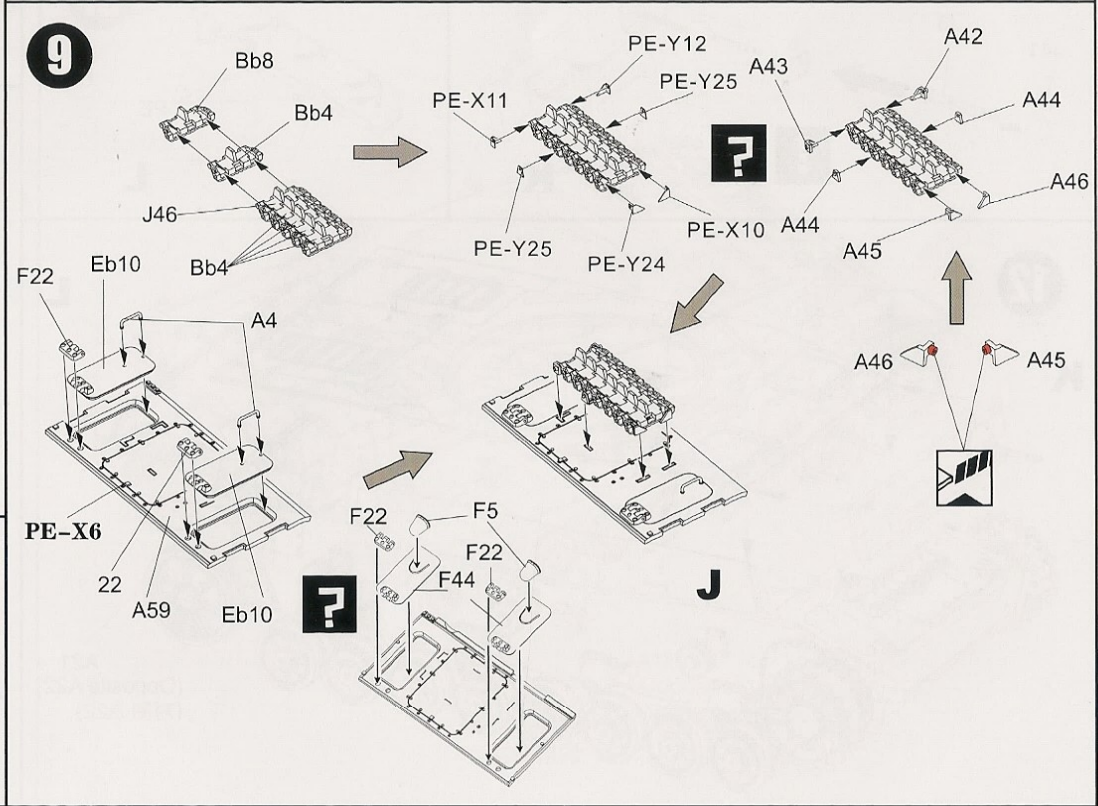
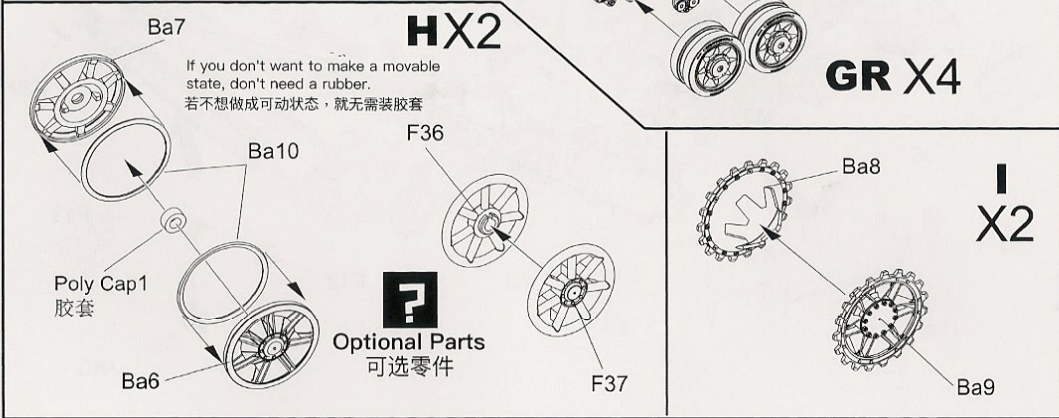
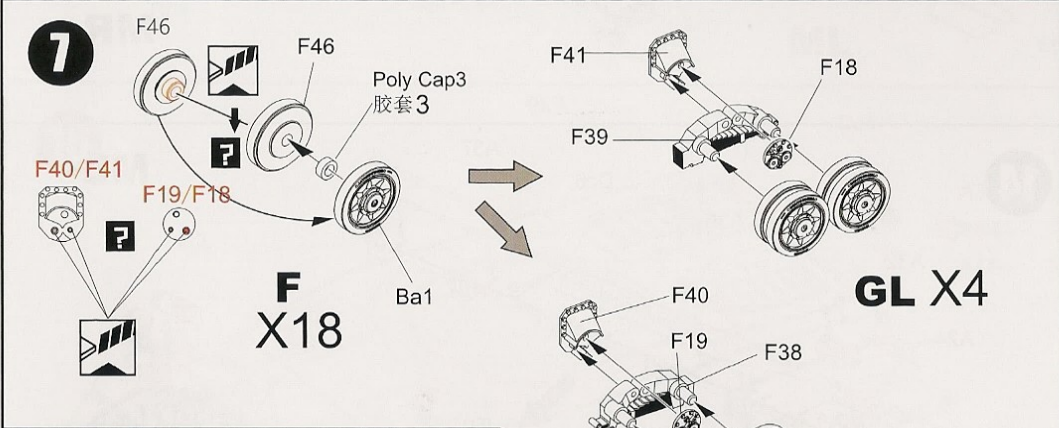
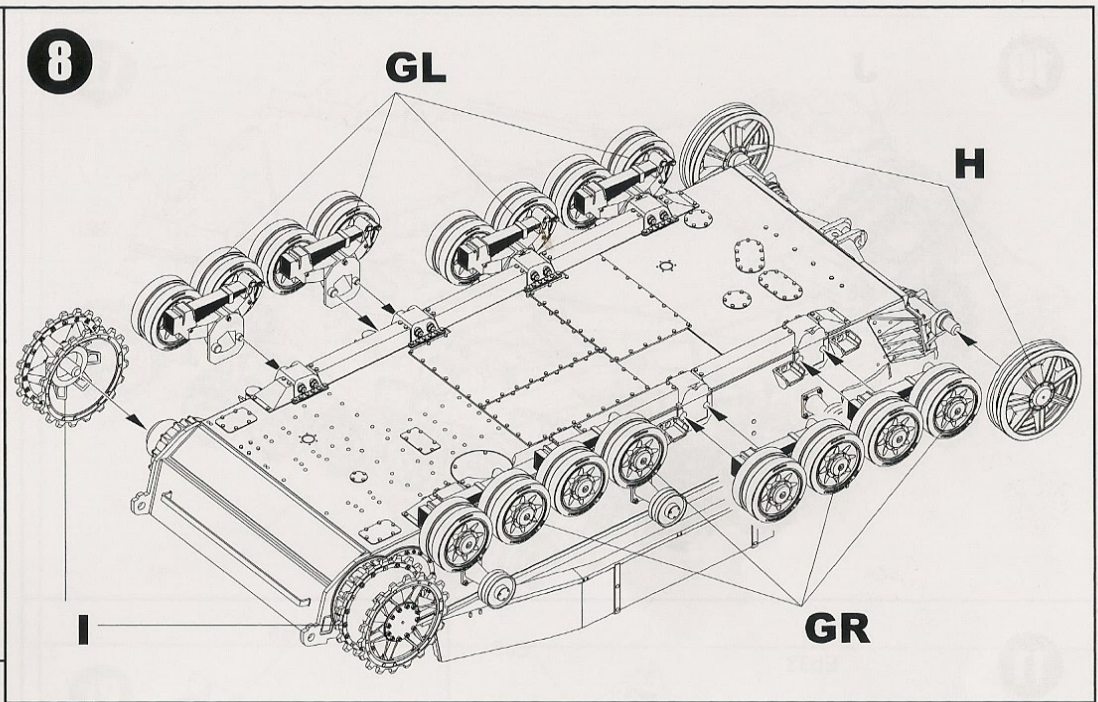
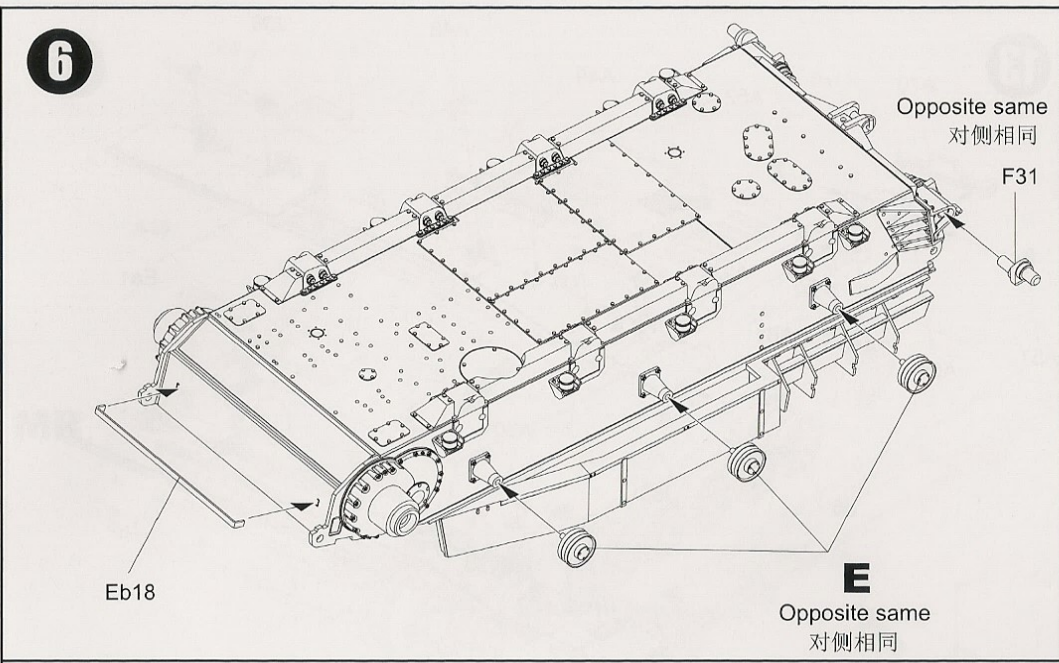

10

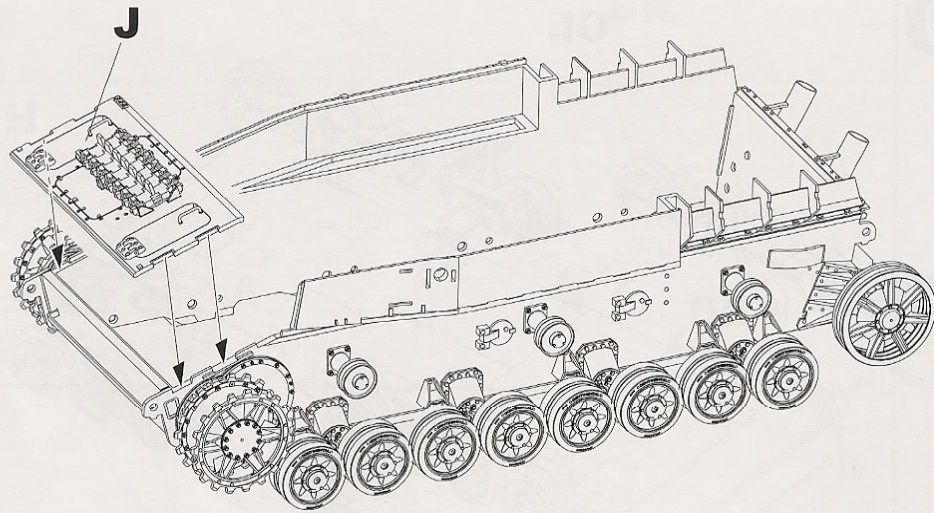

11

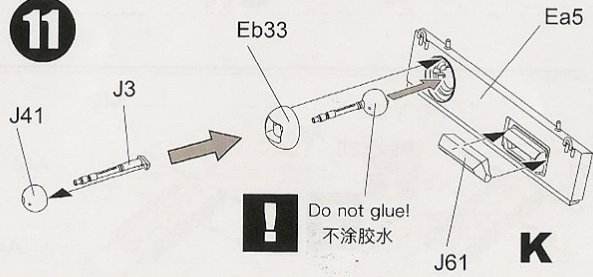

! Do not glue!
不涂胶水

K

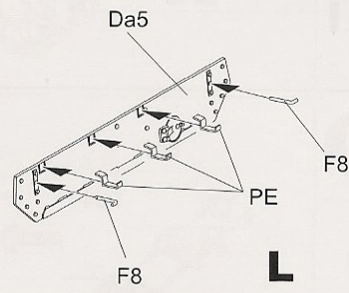

L

12

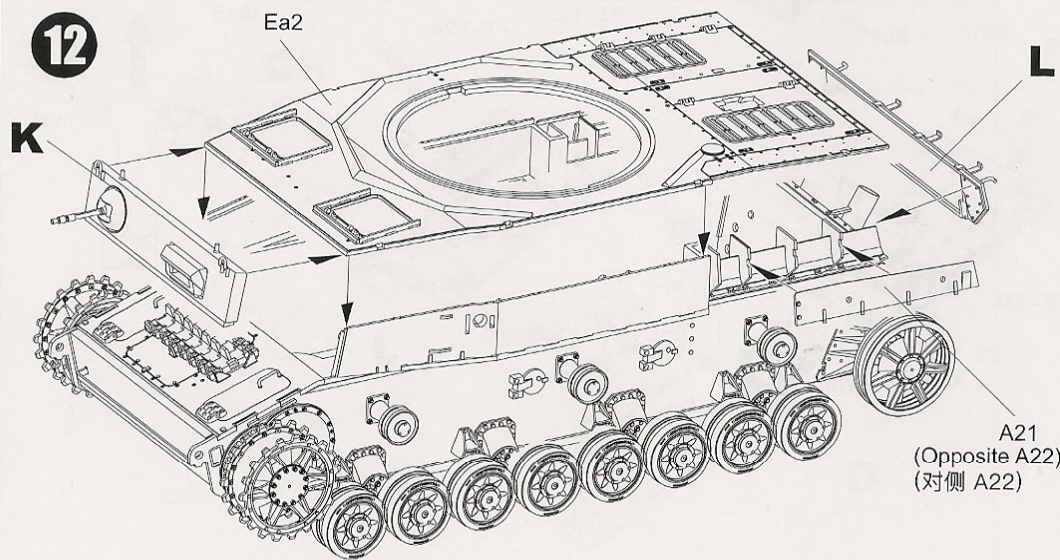

A21
(Opposite A22)
(对侧 A22)

13

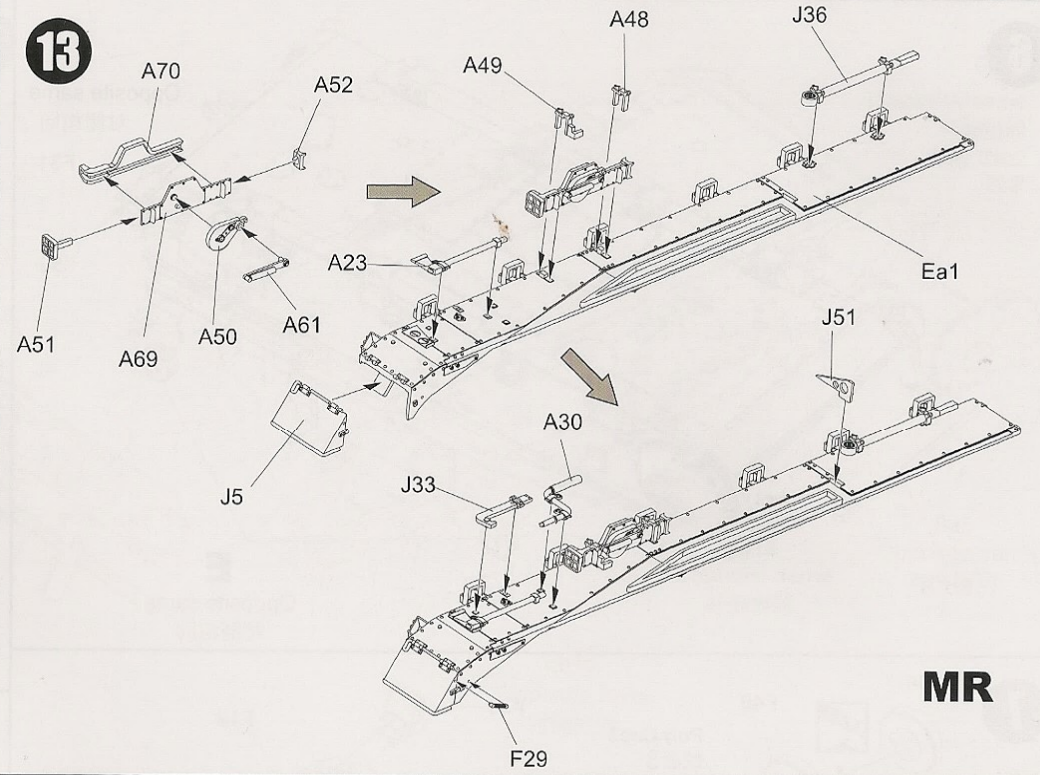

MR

14

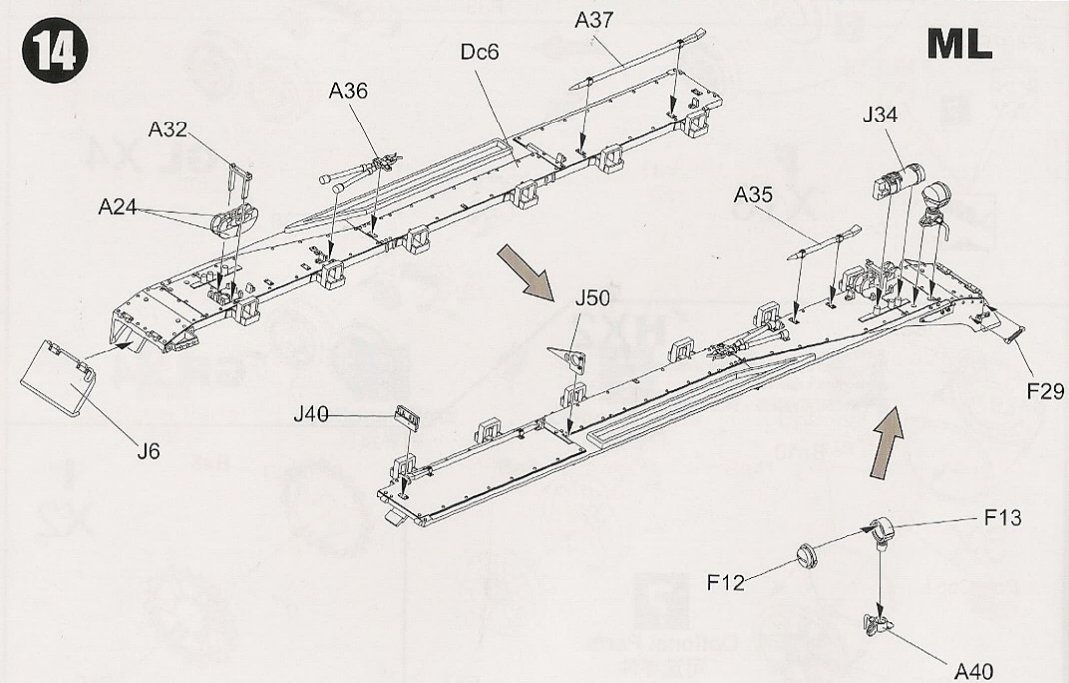

ML

15

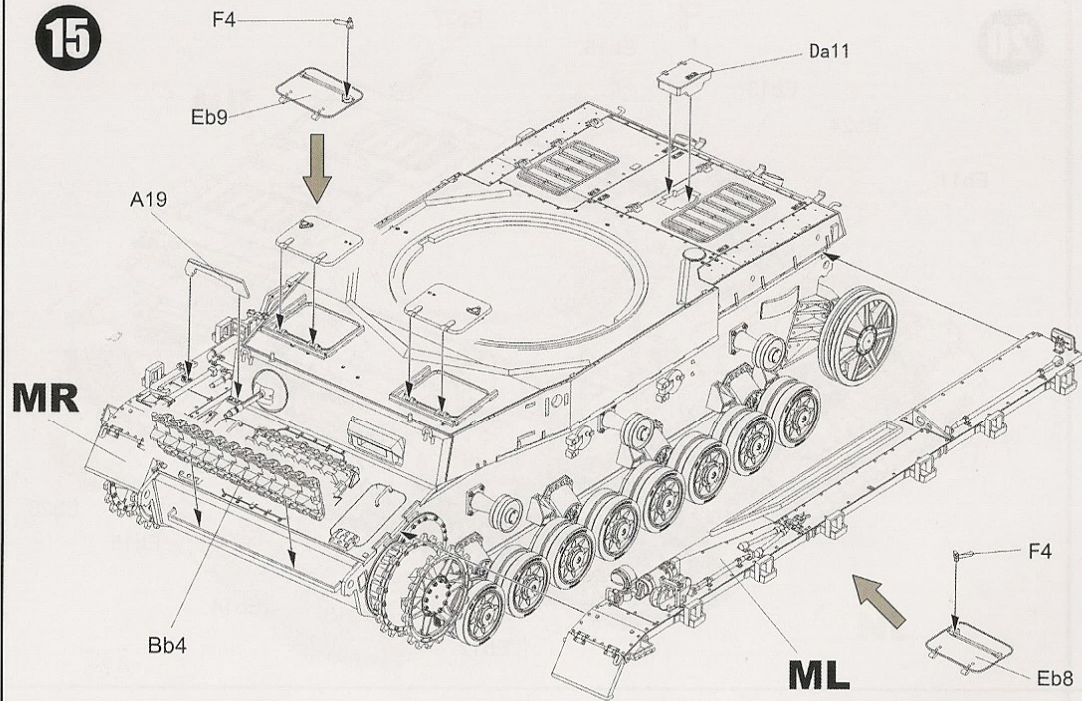

17

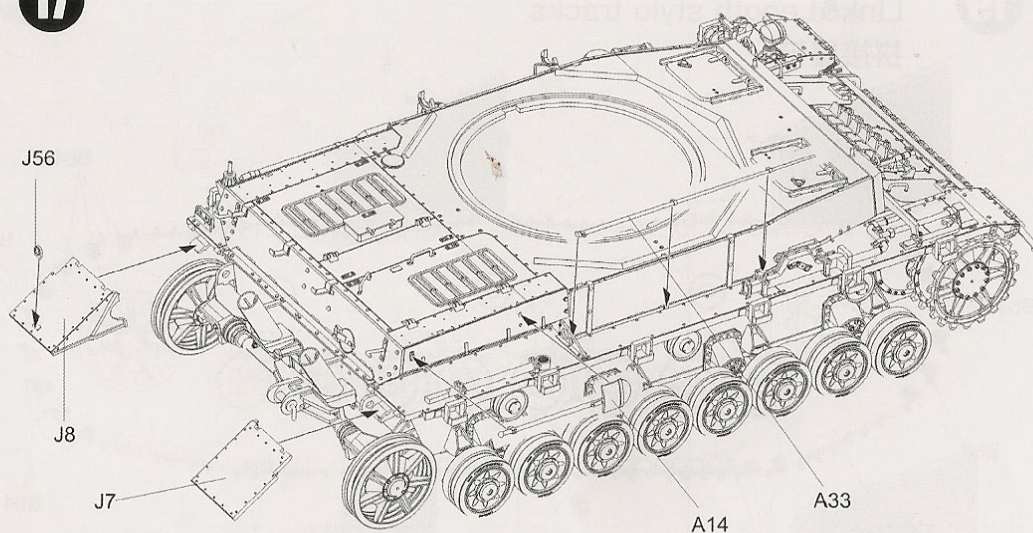

16

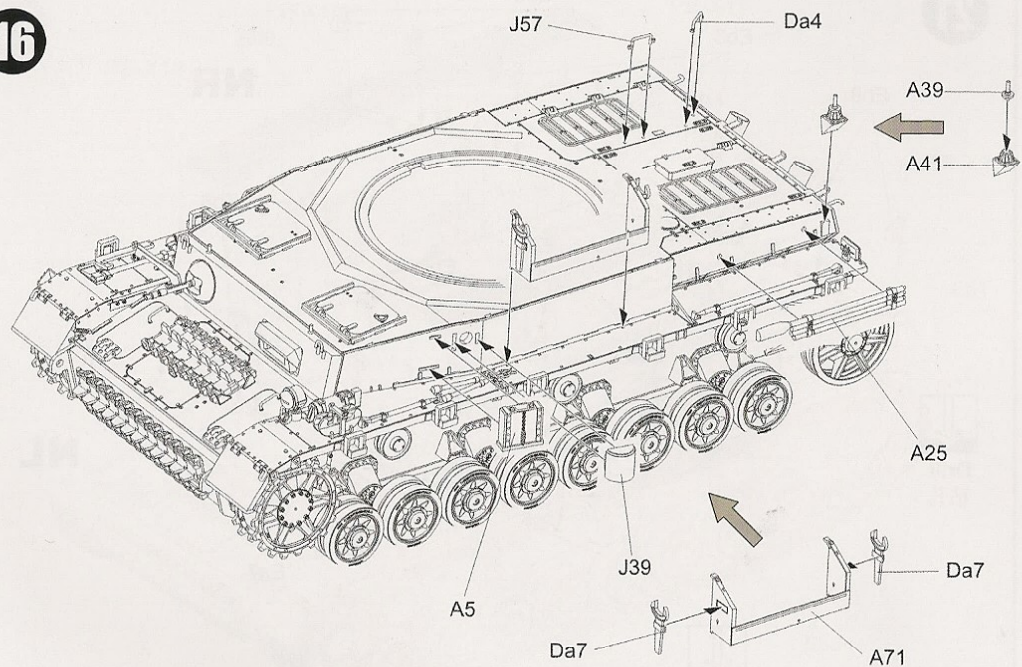

18

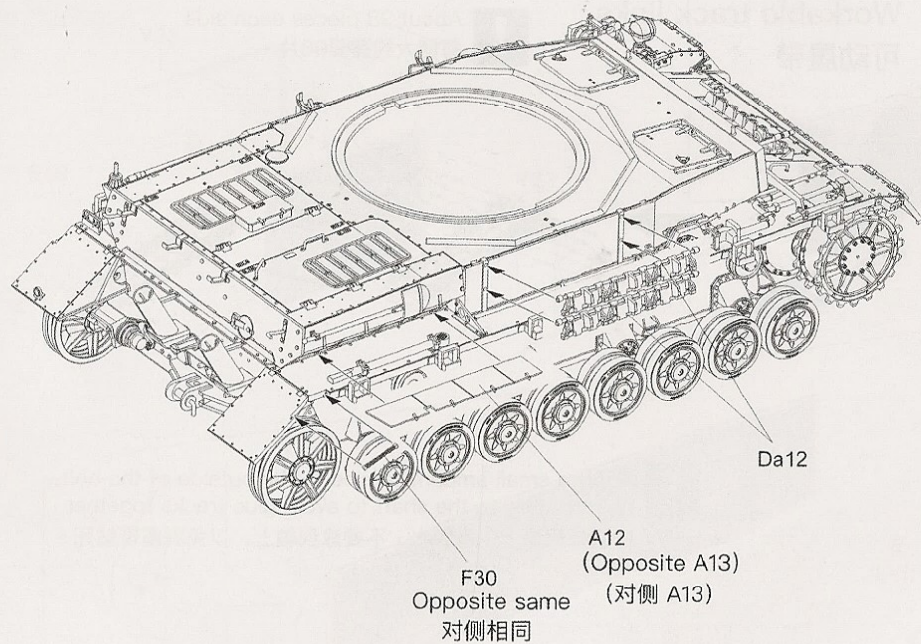

19

Link&Length style tracks 拼接履带

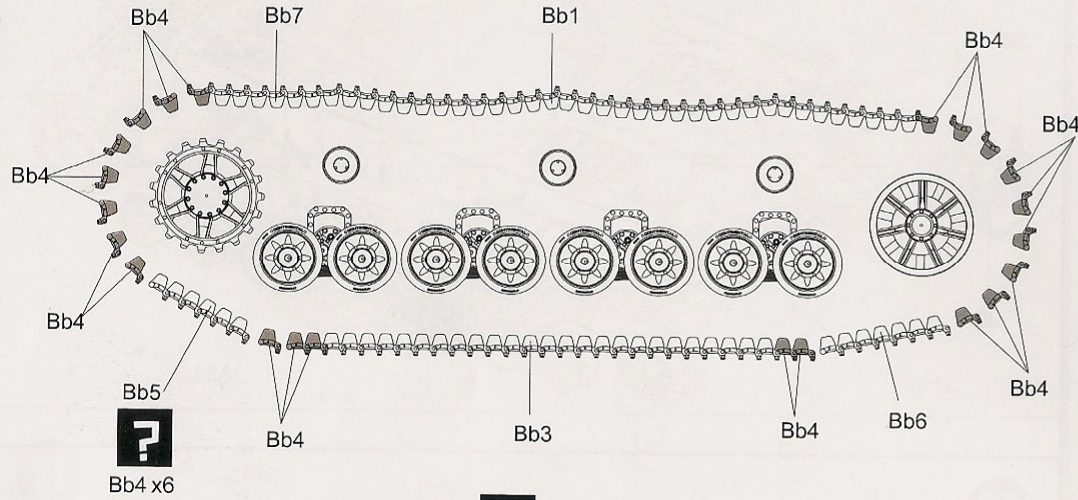

Optional Parts
可选零件

Workable track links 可动履带

! About 98 pieces each side
每侧大约需要98片

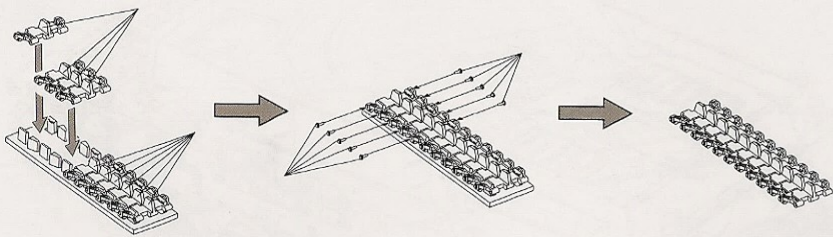

! Apply a small amount of glue to the outside of the bolt, do not apply to the shaft to avoid glue tracks together.
插销外侧涂上少量胶水，不要涂到轴上，以免将履带粘死。

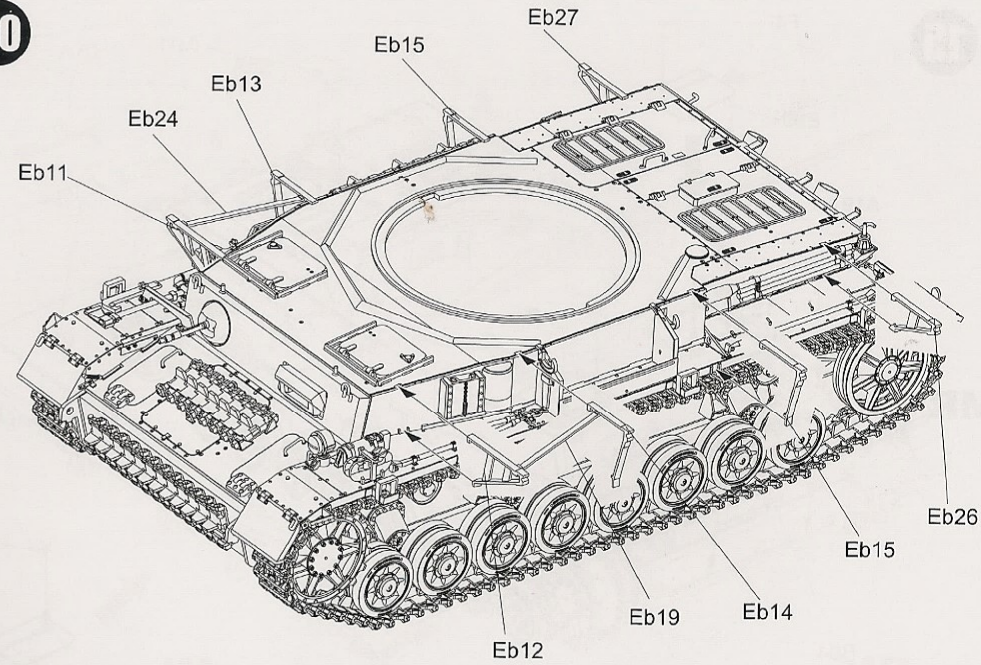
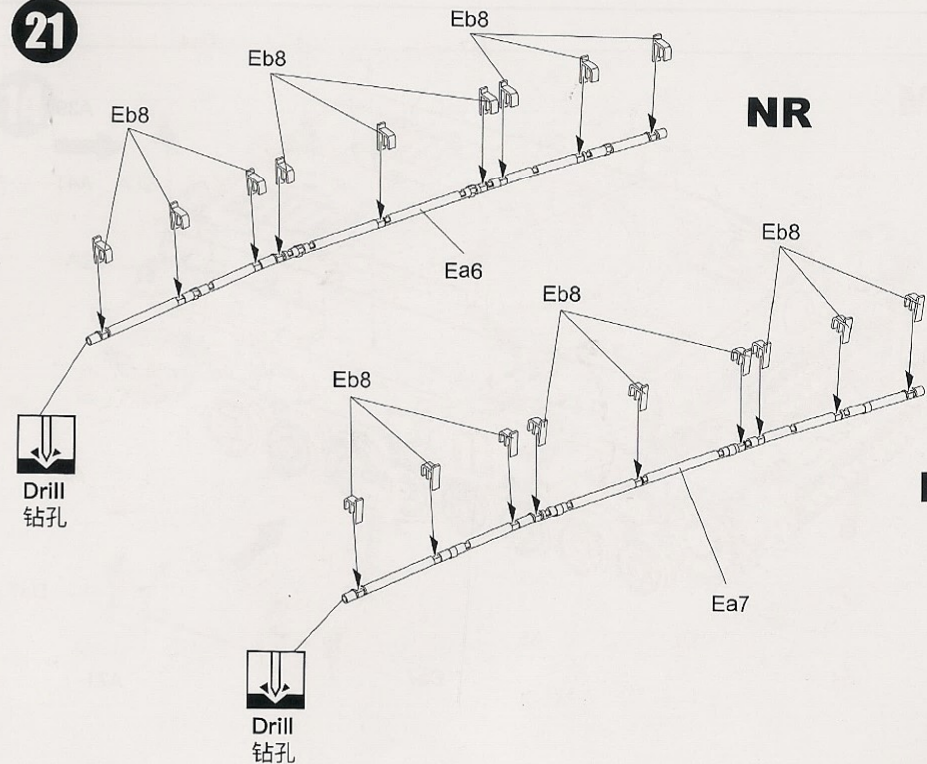
20**21**

22

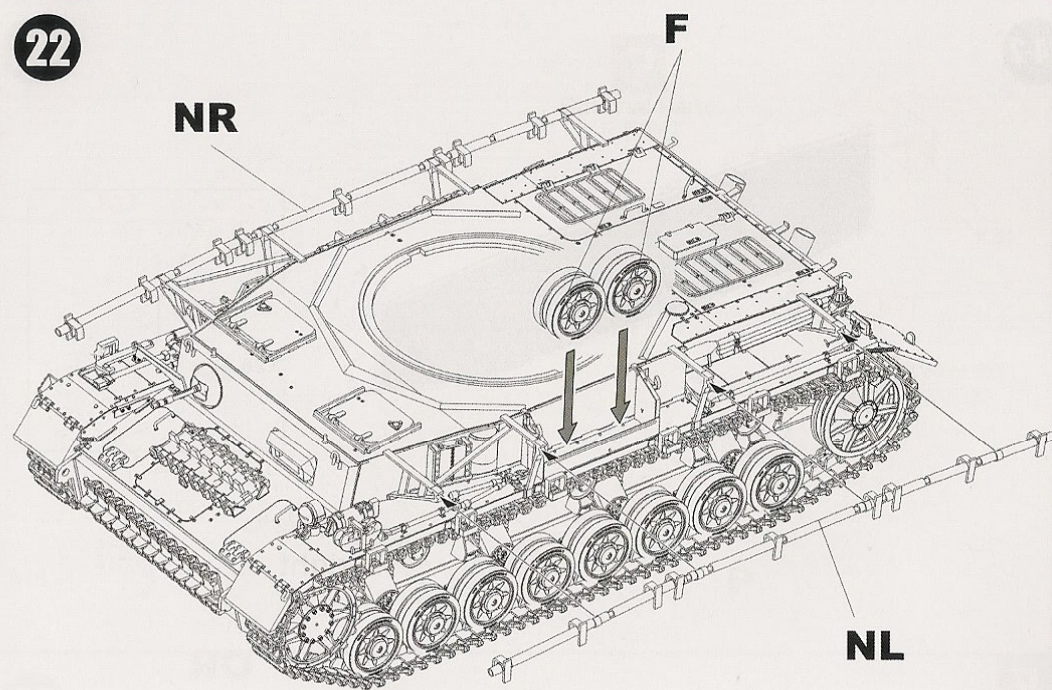

23

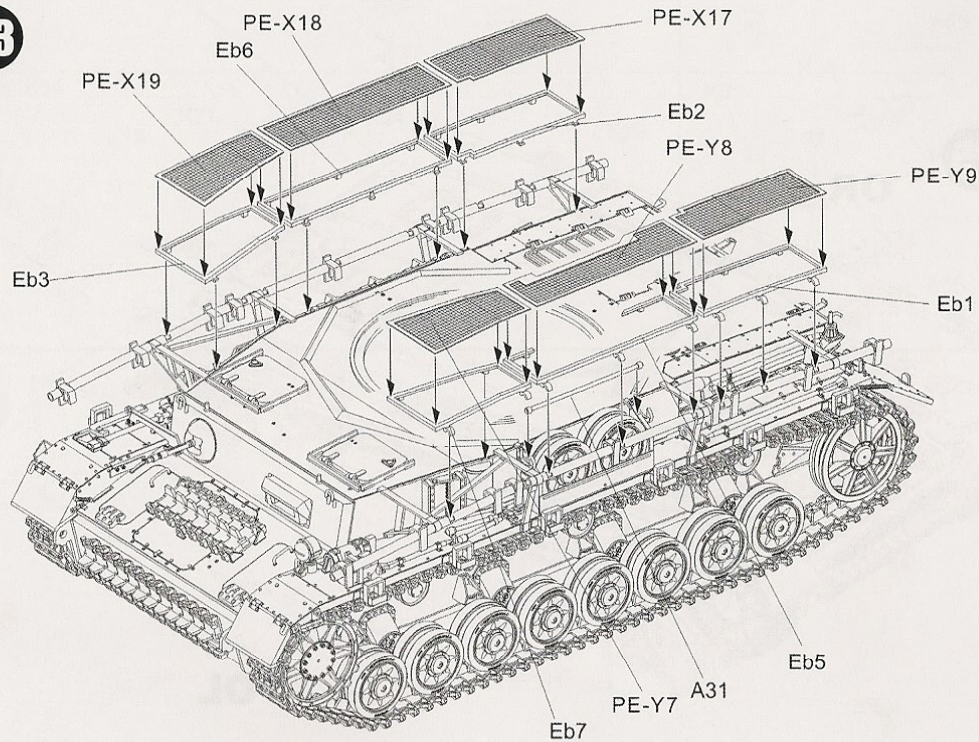

24-1

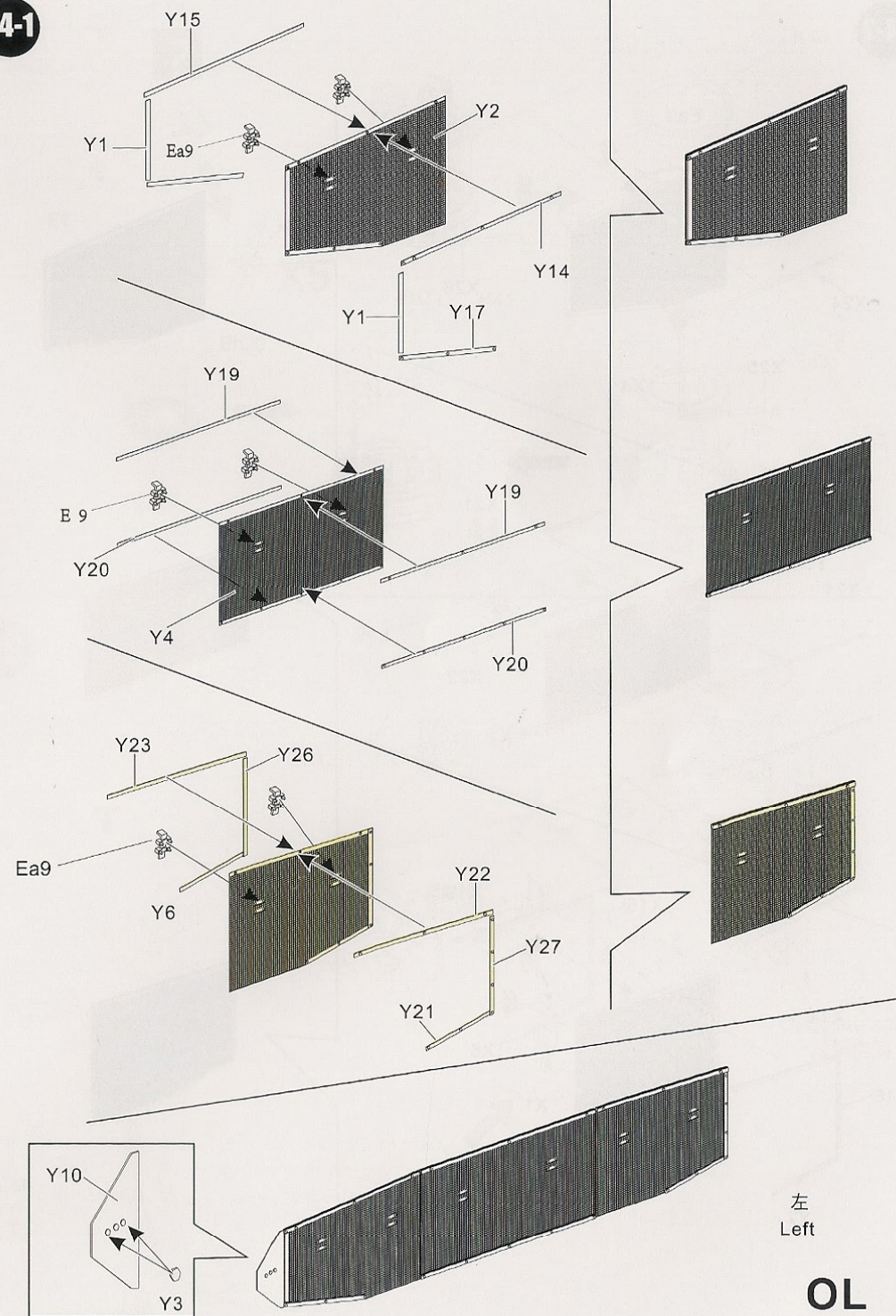

24-2

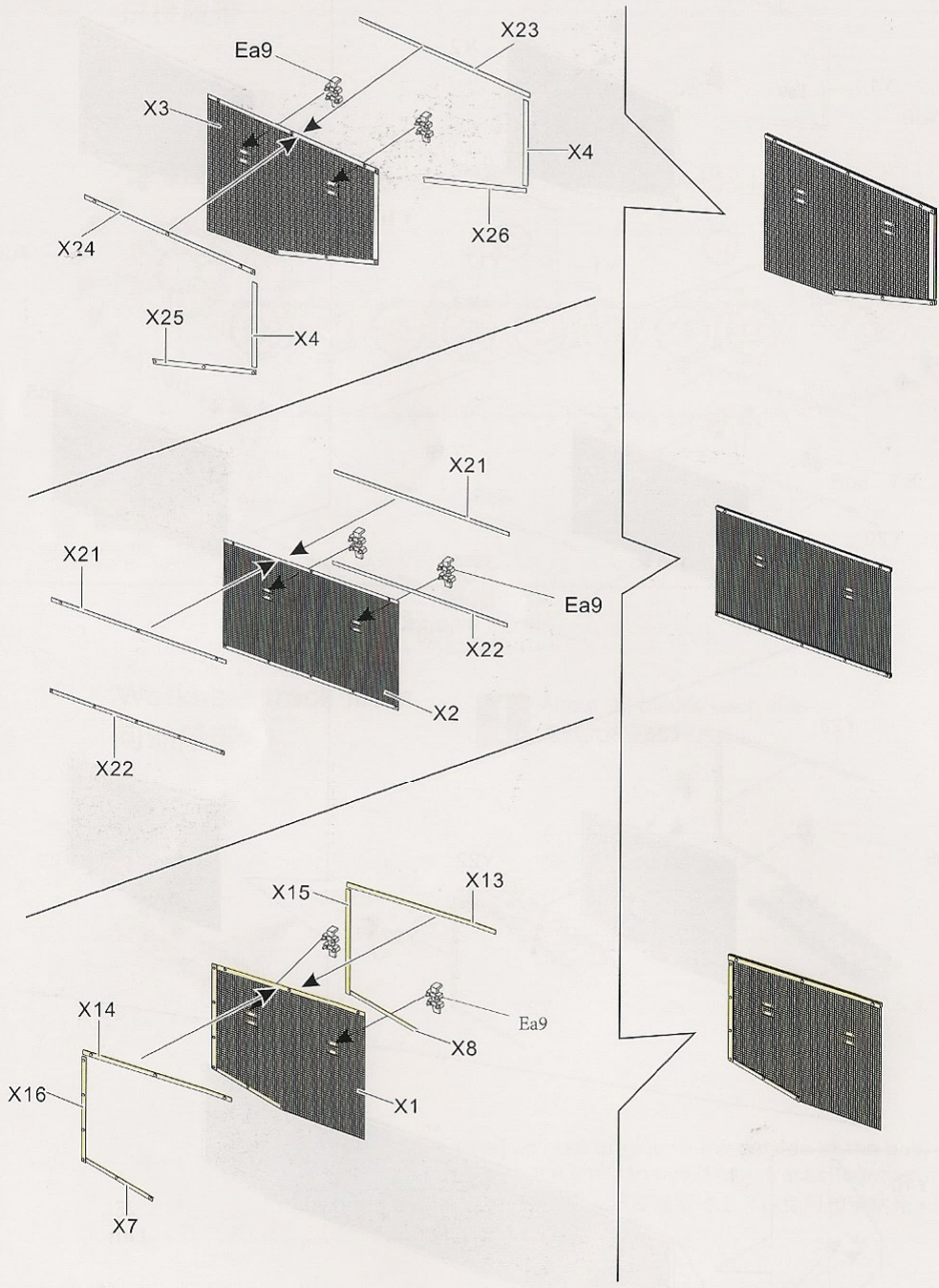

24-2

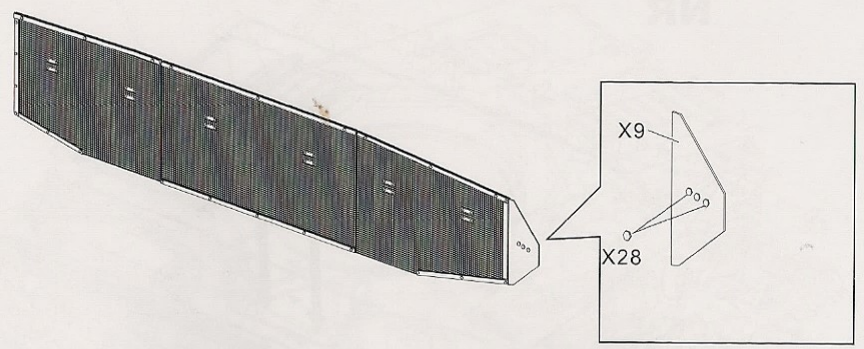

右
right

OR

25

OR

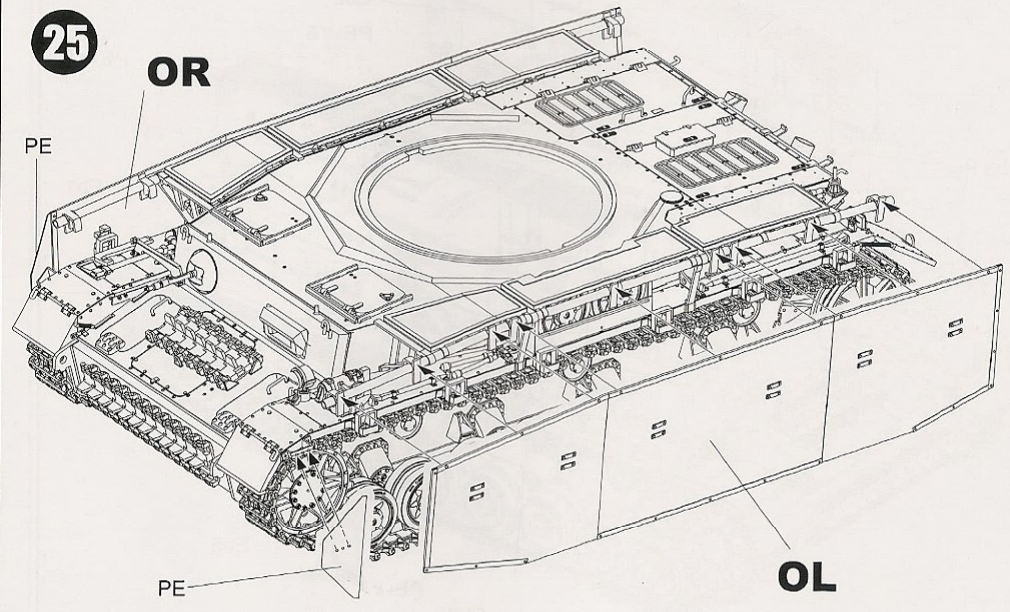

26

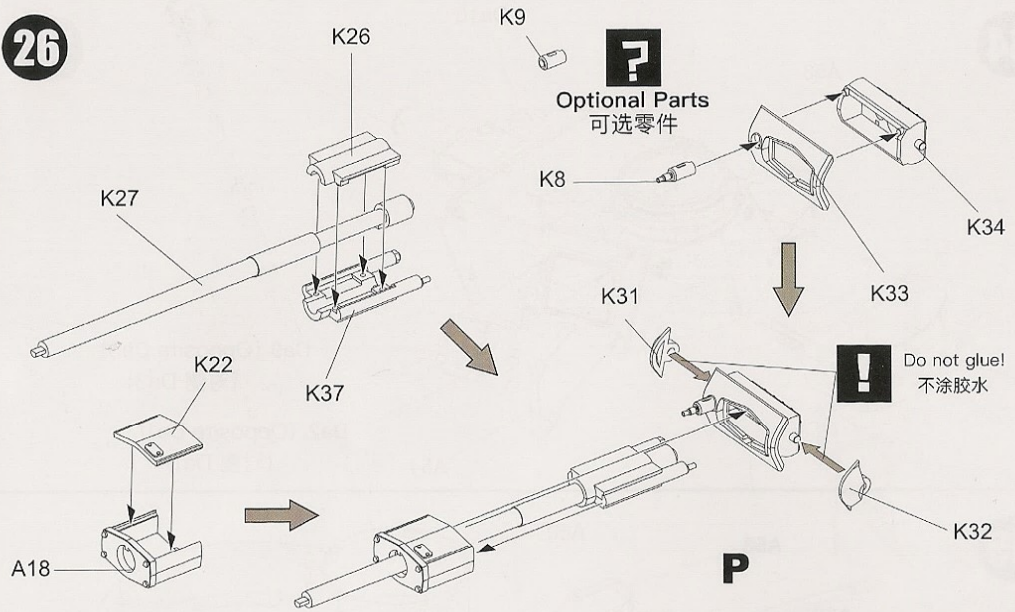

29

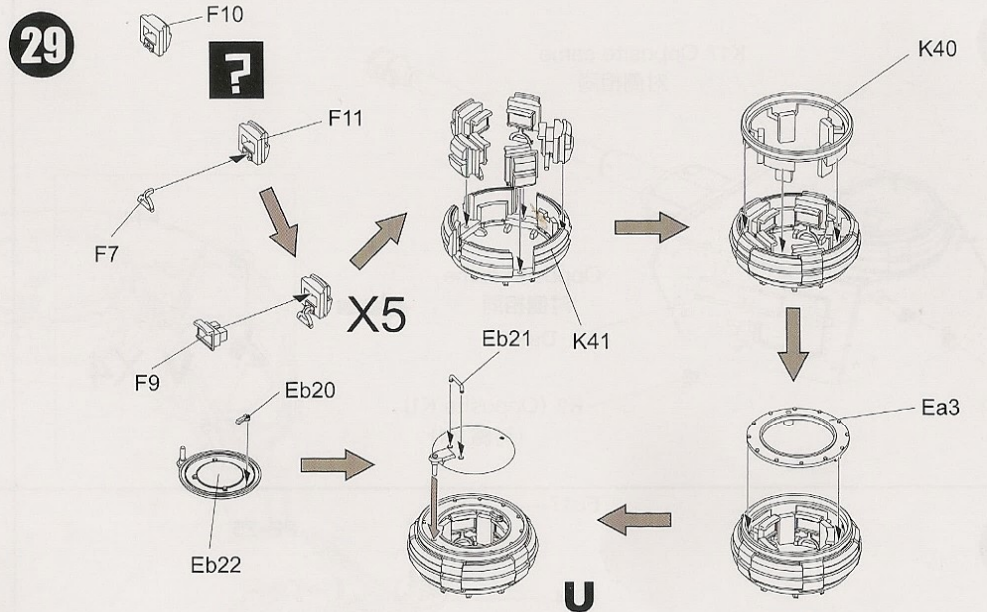

27

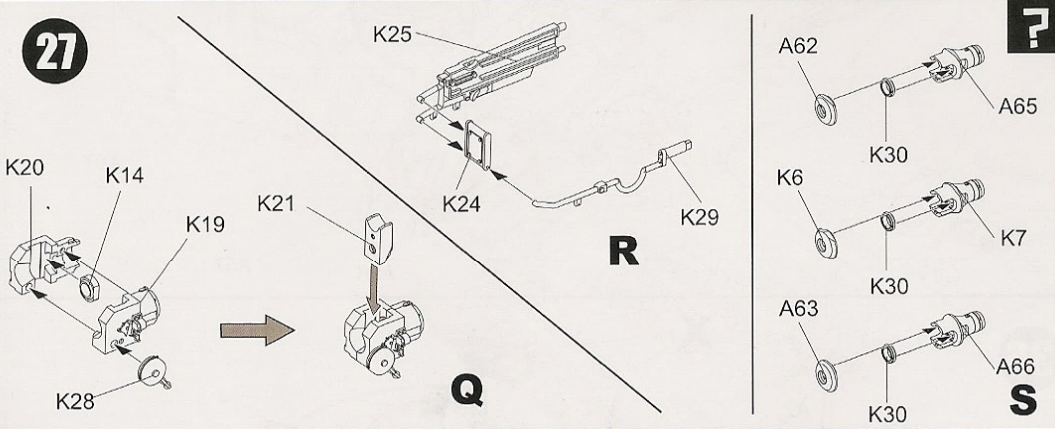

28

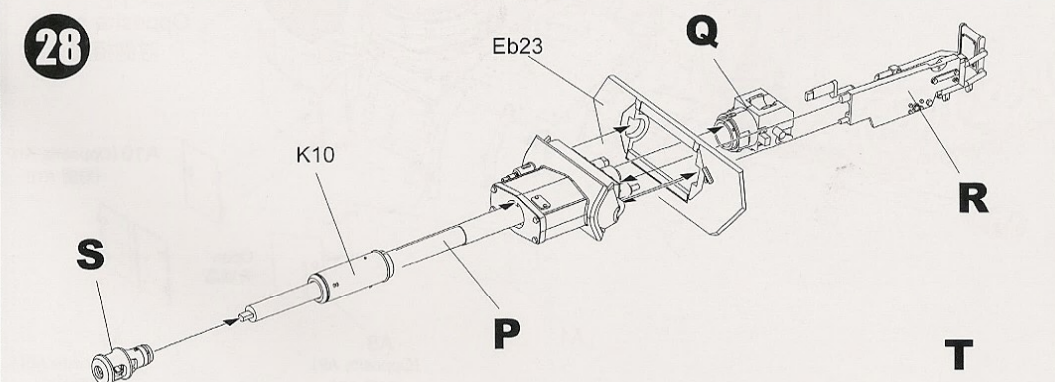

30

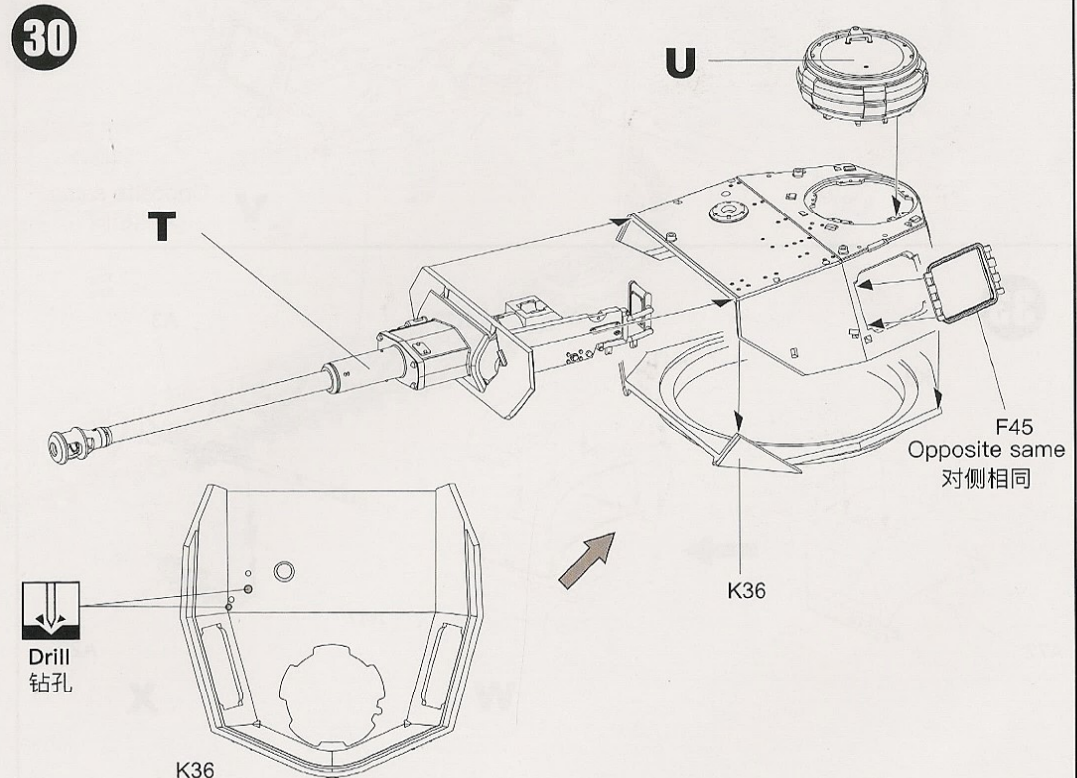

31

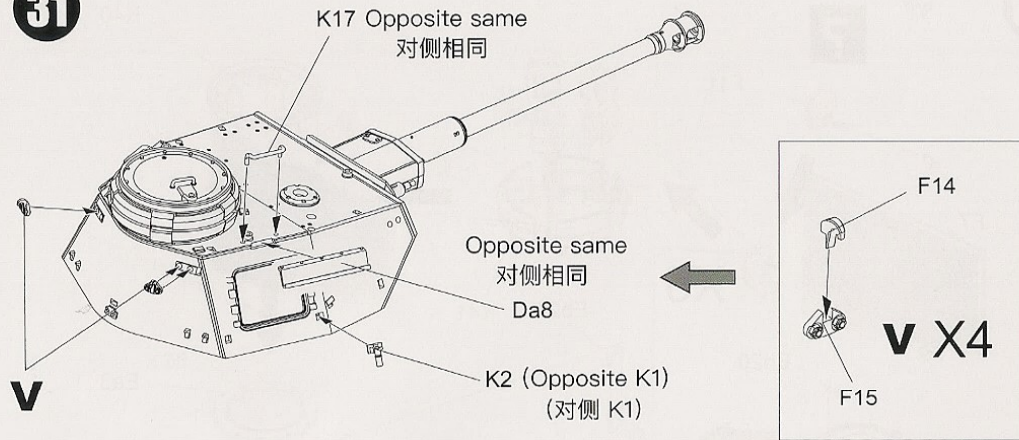

34

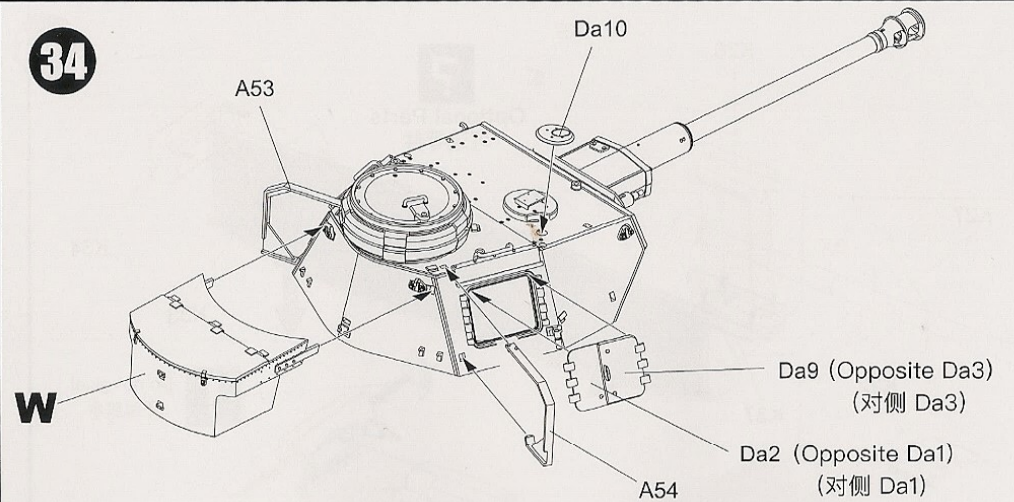

32

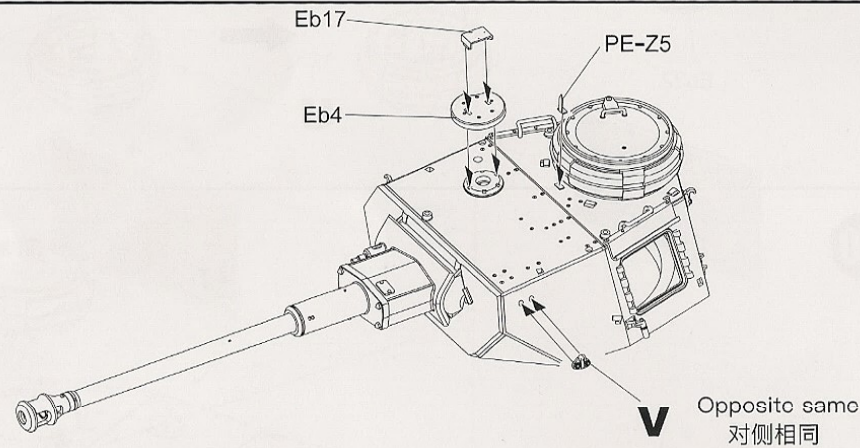

35

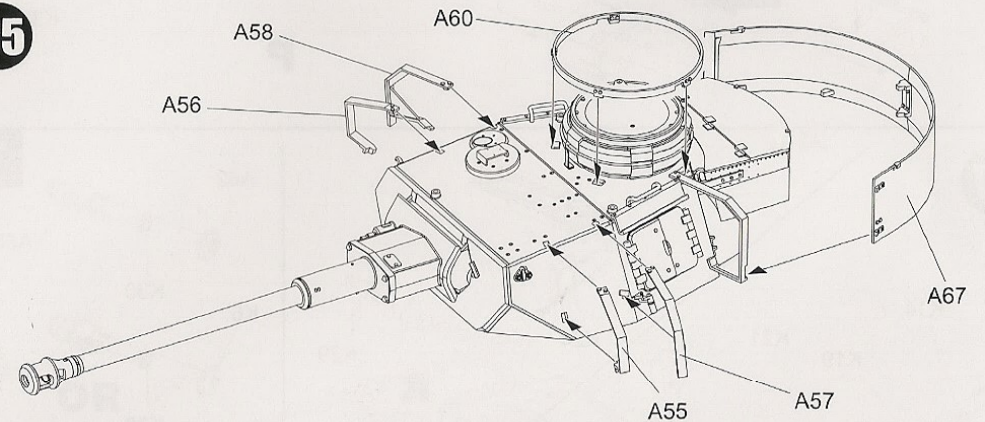

33

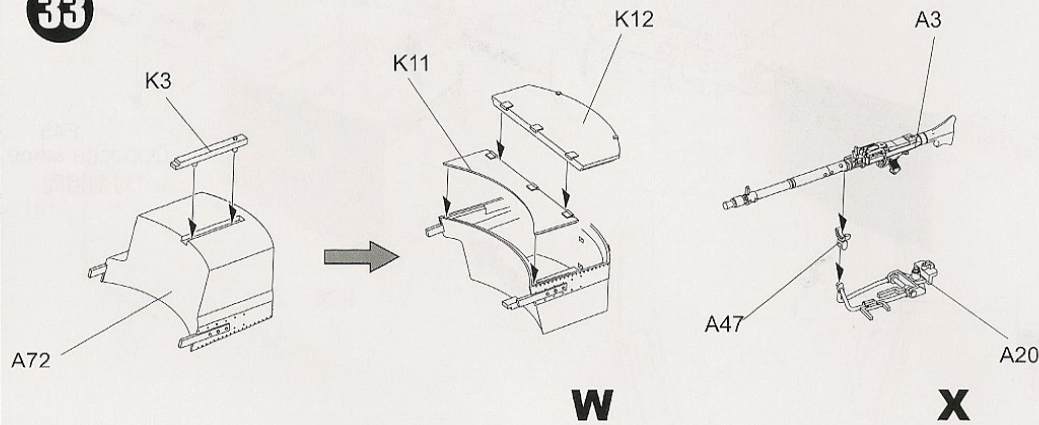

36

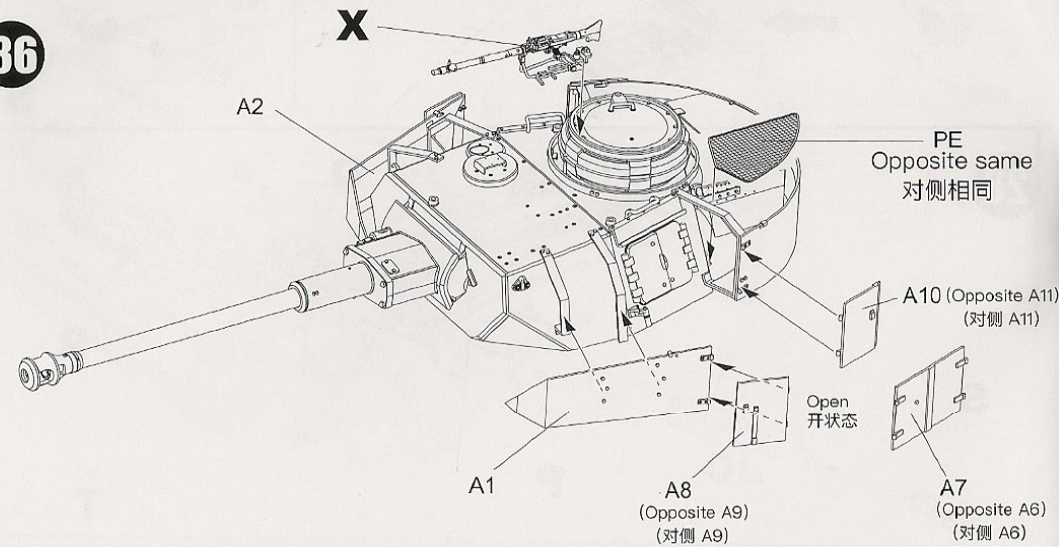

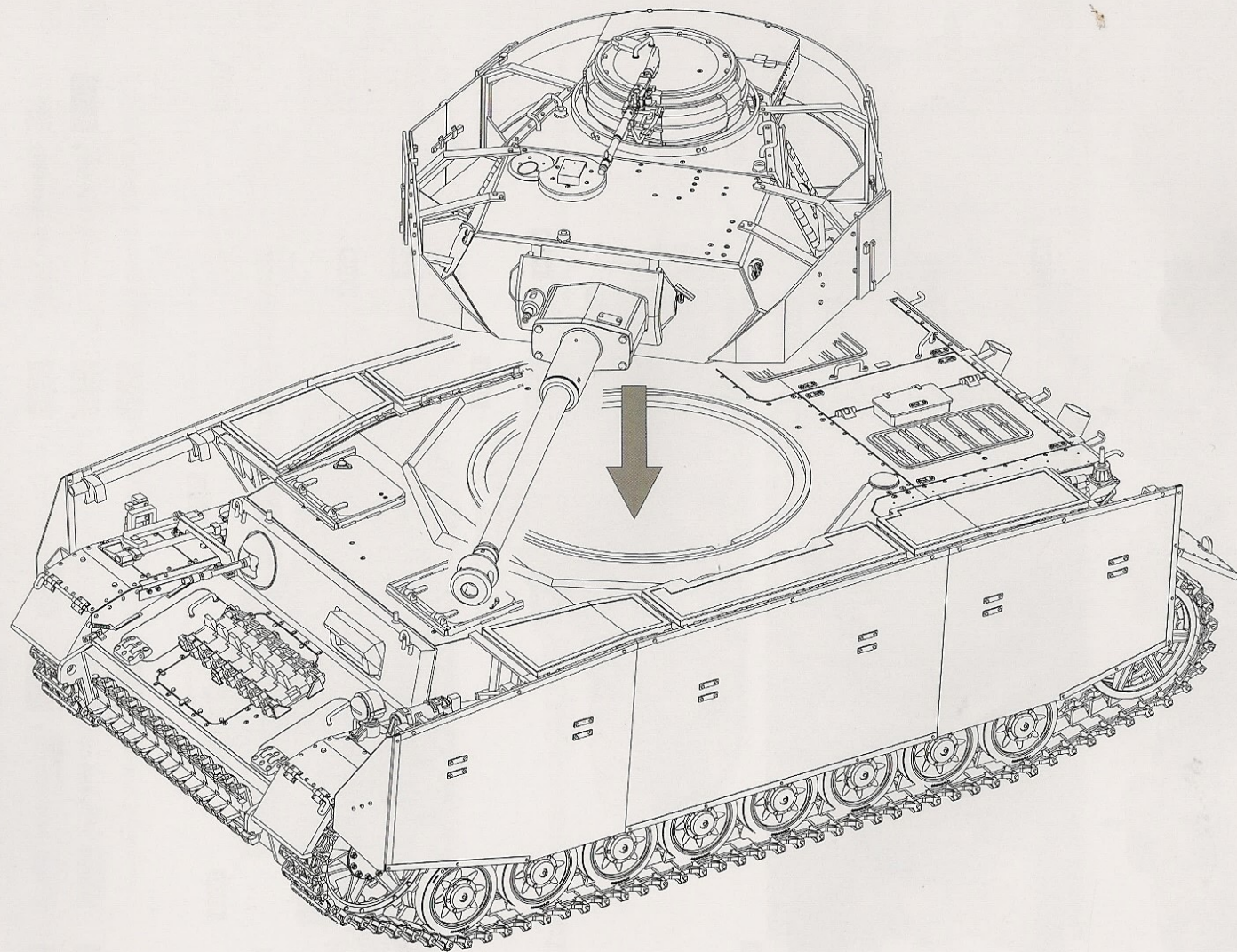

PZ.KPFW.IV AUSF. J

LATE PRODUCTION

PAINTING AND MARKING GUIDE

BORDER MODEL REF: BT-008 Pz Kpfw.IV Ausf. J Late

	A.MIG-0045 Gun Metal		A.MIG-0032 Satin Black		A.MIG-0035 Dark Tracks
	A.MIG-0033 Rubber & Tires		A.MIG-0038 Light Wood		A.MIG-0092 Crystal Black Blue
	A.MIG-0011 Dunkelgrün Ausf.44 DGI		A.MIG-0004 B Rasendagrün		A.MIG-0015 Schokobraun
					A.MIG-0042 Old Rust
					A.MIG-0908 Dunkelgrau B

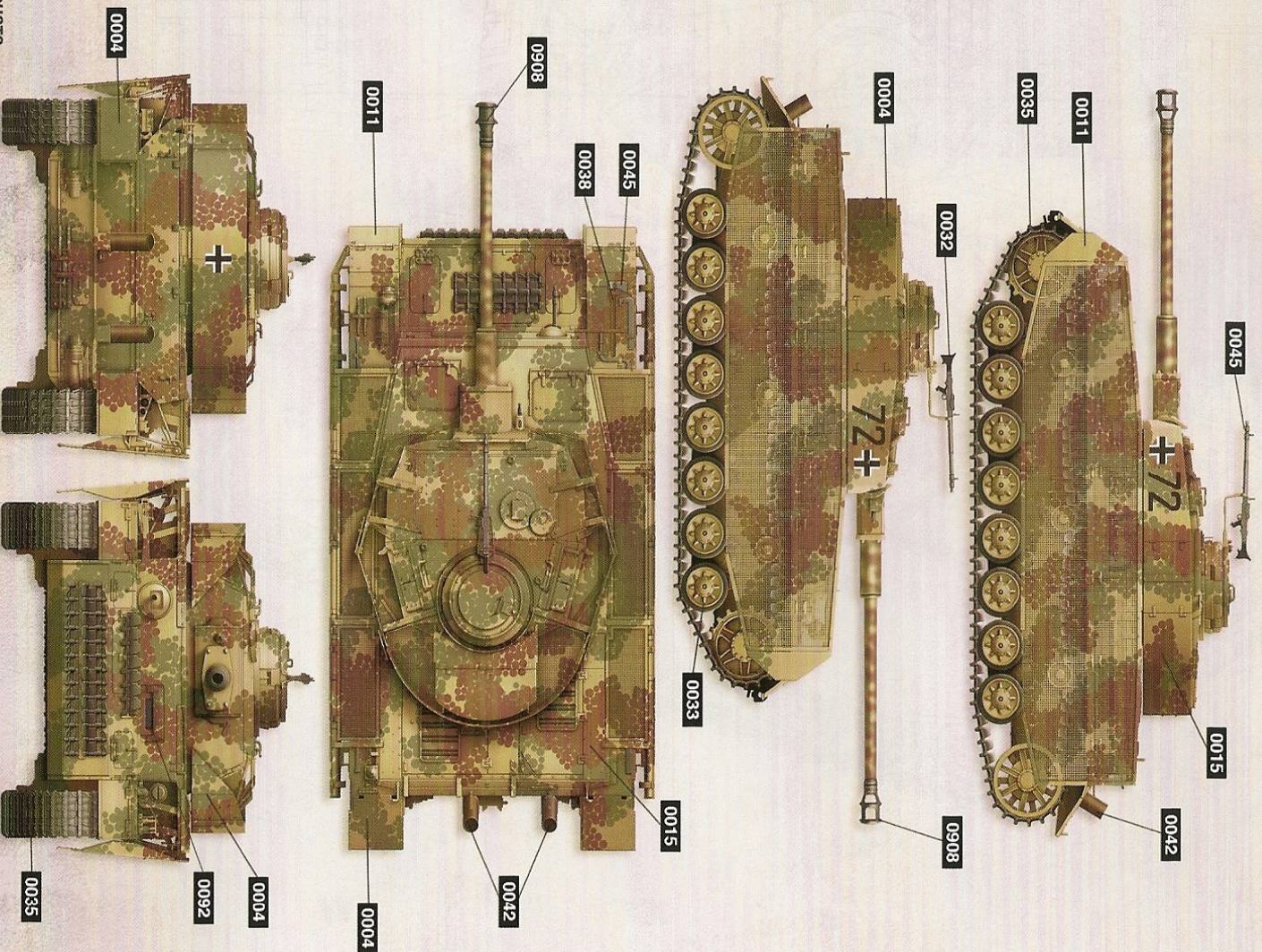

WEATHERING STEPS WITH AMMO PRODUCTS

- 1** GENERAL WASH
A.MIG-1000 Brown Wash for Dark Yellow
- 2** FILTER
A.MIG-1510 Tan for 3 Tone Camo

- 3** STREAKING
A.MIG-1256 Streakingbuster Green-Grey Grime
- 4** TRACK WASH
A.MIG-1002 Tracks Wash

- 5** RUST
A.MIG-1204 Streaking Rust Effects
- 6** DUST
A.MIG-3004 Europe Earth

- 7** MUD & SPLASHES
A.MIG-1704 Heavy Earth A.MIG-1753 Turned Dirt
- 8** FUEL & OIL
A.MIG-1409 Fuel Stains A.MIG-1408 Fresh Engine

PZ.KPFW.IV AUSF. J

LATE PRODUCTION

PAINTING AND MARKING GUIDE

BORDER MODEL REF: BT-008 Pz.Kpfw.IV Ausf. J Late

	A.MIG-0045 Gun Metal		A.MIG-0032 Satin Black		A.MIG-0035 Dark Tracks		A.MIG-0042 Old Rust
	A.MIG-0033 Rubber & Tires		A.MIG-0038 Light Wood		A.MIG-0092 Crystal Black Blue		A.MIG-0908 Dunkelgrau Base
	A.MIG-0012 Dunkelgrau Ausf. J4 DG III		A.MIG-0003 Resedagrün		A.MIG-0014 Rotbraun		

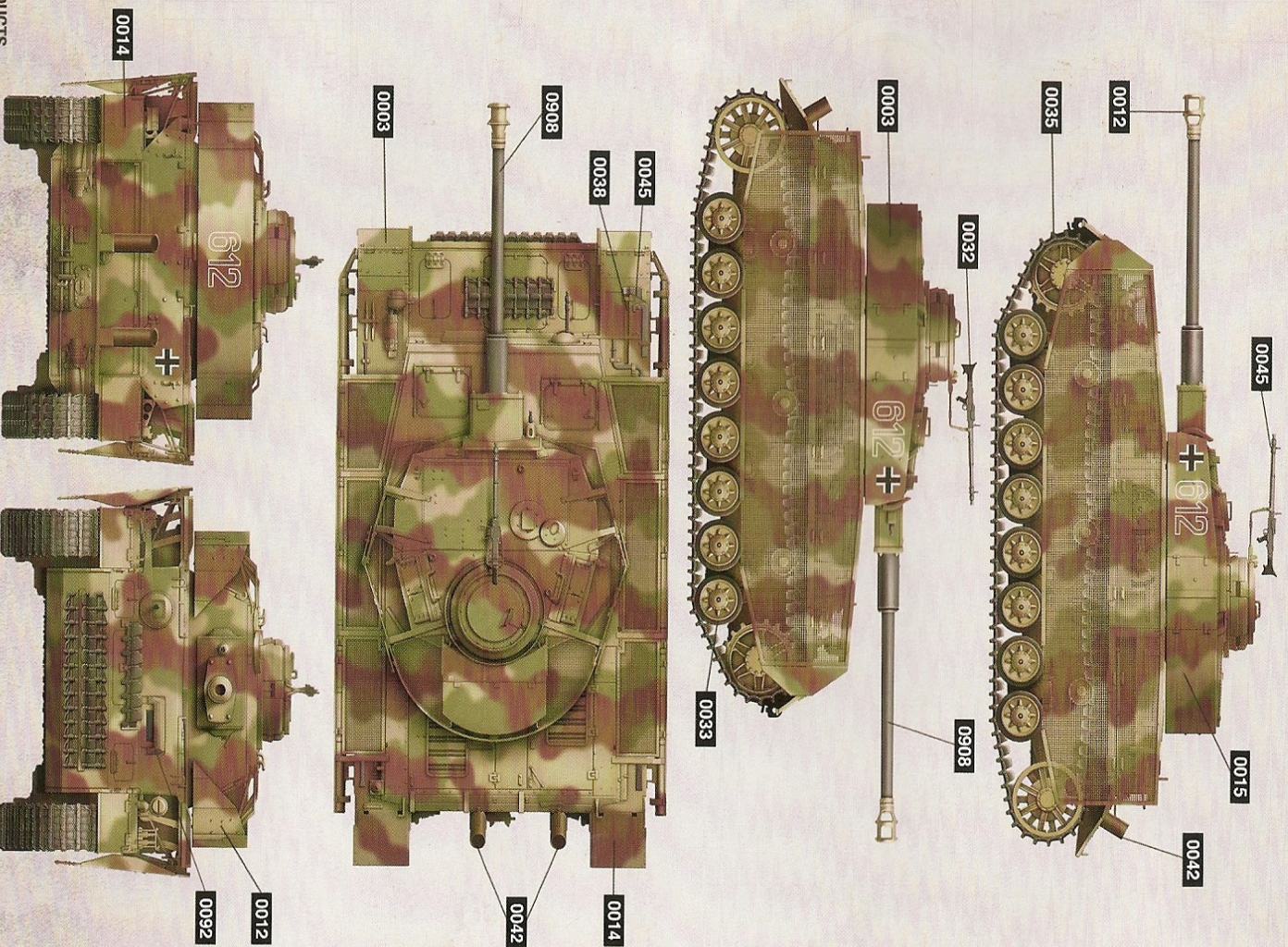

WEATHERING STEPS WITH AMMO PRODUCTS

- 1 GENERAL WASH**
A.MIG-1000 Brown Wash for Dark Yellow
- 2 FILTER**
A.MIG-1510 Tan for 3 Tone Camo
- 3 STREAKING**
A.MIG-1253 Streakingbrusher Grime
- 4 TRACK WASH**
A.MIG-1002 Tracks Wash
- 5 RUST**
A.MIG-1254 Streakingbrusher Rust
- 6 DUST**
A.MIG-3013 Rubble
- 7 MUD & SPLASHES**
A.MIG-1703 Moist Ground A.MIG-1752 Loose Ground
- 8 GREASE & OIL**
A.MIG-1408 Fuel Stains A.MIG-1408 Fresh Engine Oil

PZ.KPFW.IV AUSF.J

LATE PRODUCTION

PAINTING AND MARKING GUIDE

BORDER MODEL REF: BT-008 Pz Kpfw.IV Ausf. J Late

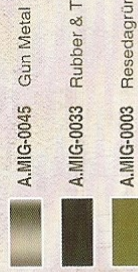

A.MIG-0046 Gun Metal

A.MIG-0033 Rubber & Tires

A.MIG-0003 Resedagrün

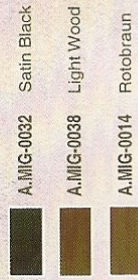

A.MIG-0032 Satin Black

A.MIG-0038 Light Wood

A.MIG-0014 Rotbraun

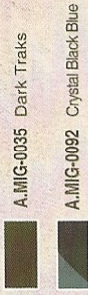

A.MIG-0035 Dark Traks

A.MIG-0092 Crystal Black Blue

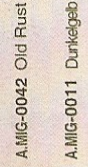

A.MIG-0042 Old Rust

A.MIG-0011 Dunkelgelb Ausf.4

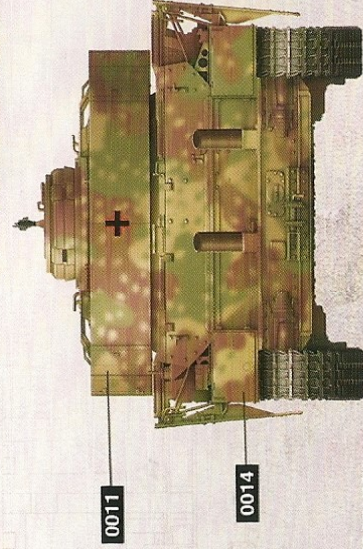
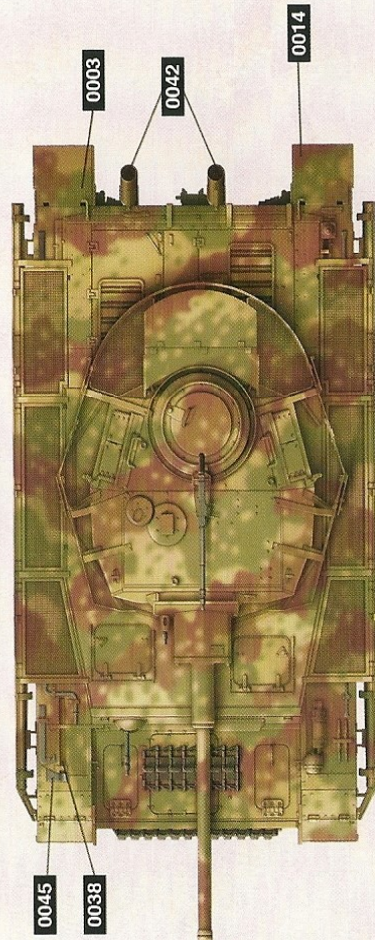
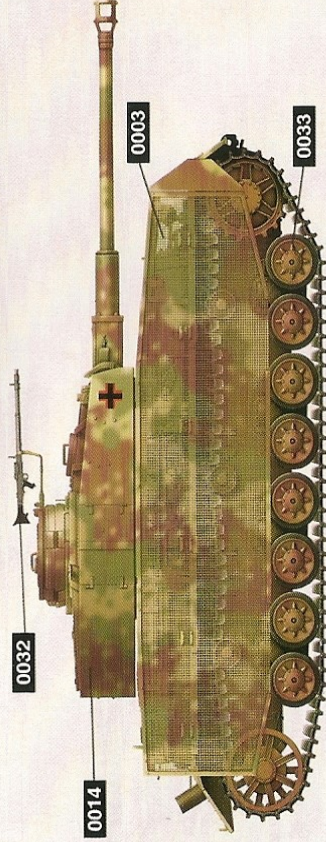
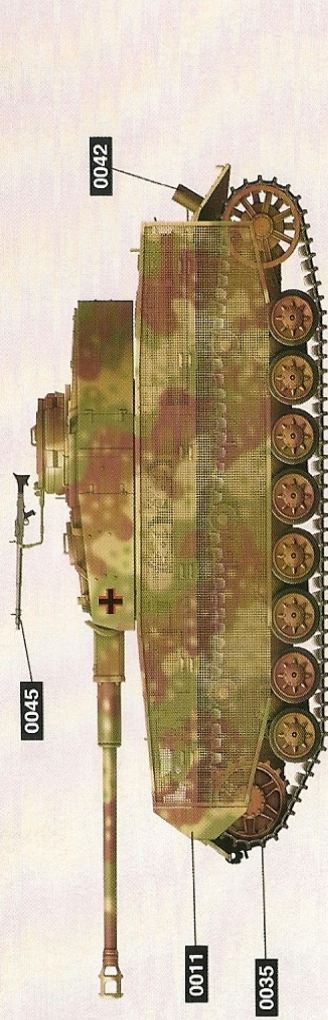

WEATHERING STEPS WITH AMMO PRODUCTS

1 GENERAL WASH

A.MIG-1000 Brown Wash for Dark Yellow

2 FILTER

A.MIG-1510 Tan for 3 Tone Camo

3 STREAKING

A.MIG-1206 Dark Streaking Grime

4 TRACK WASH

A.MIG-1002 Tracks Wash

5 RUST

A.MIG-3510 Oilbrusher Rust

6 DUST

A.MIG-3028 City Dark Dust

7 MUD & SPLASHES

A.MIG-1705 Wet Mud

8 Fuel & Oil

A.MIG-1409 Fuel Stains A.MIG-1408 Fresh Engine



PZ.KPFW.IV



TRANSFORM
易模型

BORDER MODEL REF:BT-008

Pz.Rgt.31, 5.Pz.Div., No.515
March 1945 East Prussia
第5装甲师 31装甲团 515号车
1945年3月 东普鲁士



TRANSFORM
易模型

**WATERBASE
PAINT**
Brush & Airbrush

CV017

CV024

CU007

CU107

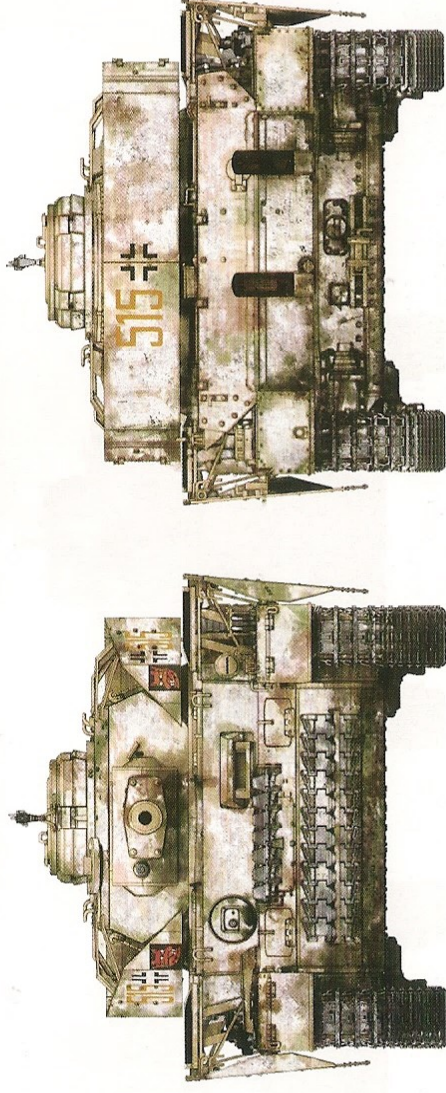
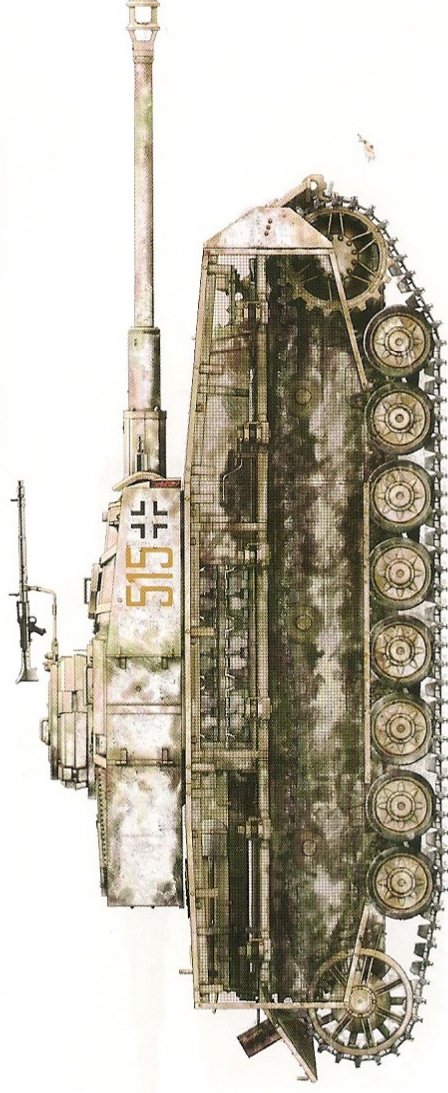
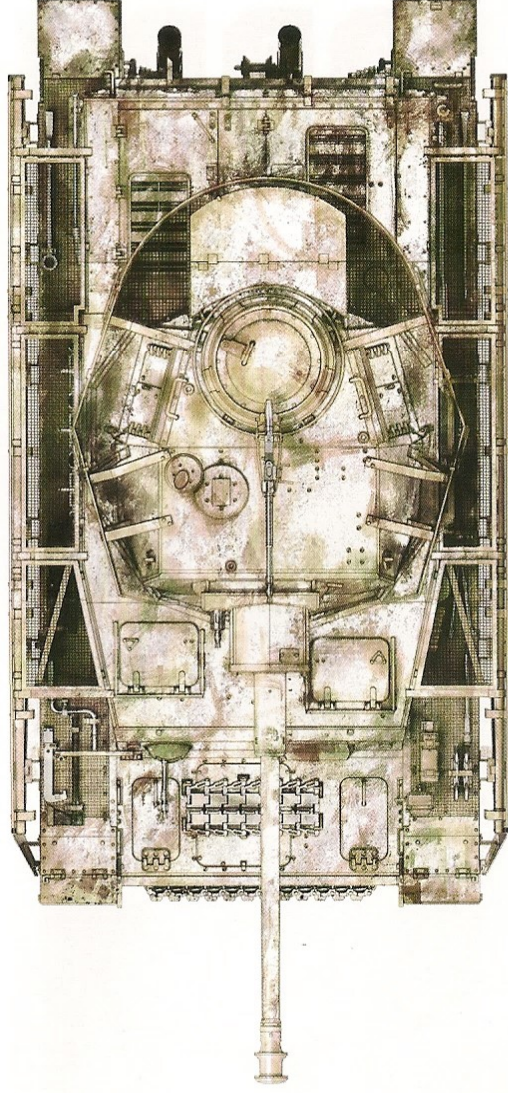
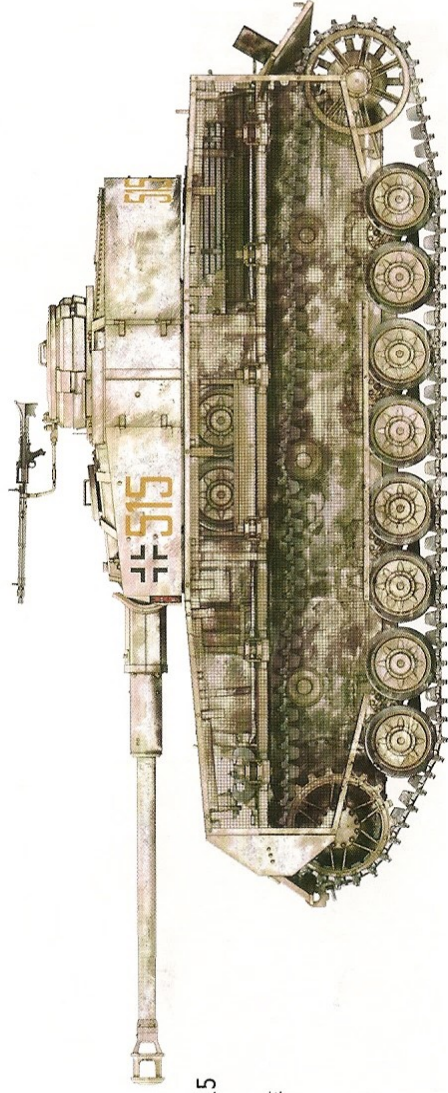



Pz.KPFW.IV



BORDER MODEL REF:BT-008

11.Pz.Div., No.33
1945 Germany
第11装甲师 33号车
1945年 德国境内



**WATERBASE
PAINT**
Brush & Airbrush

CV017

CV018

CU007

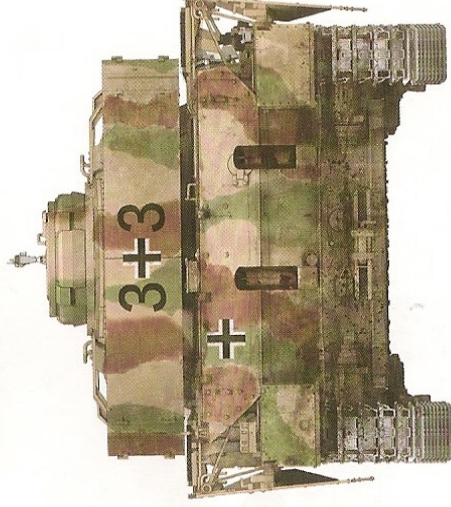
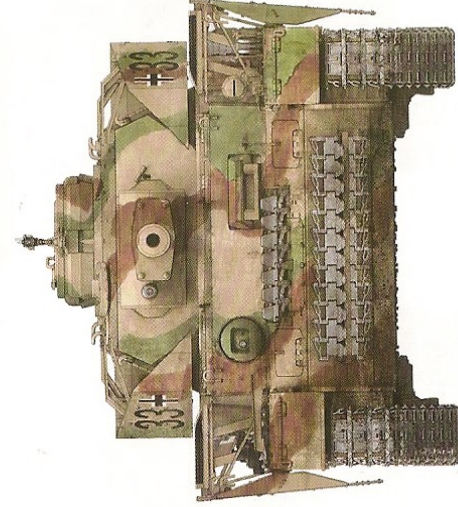
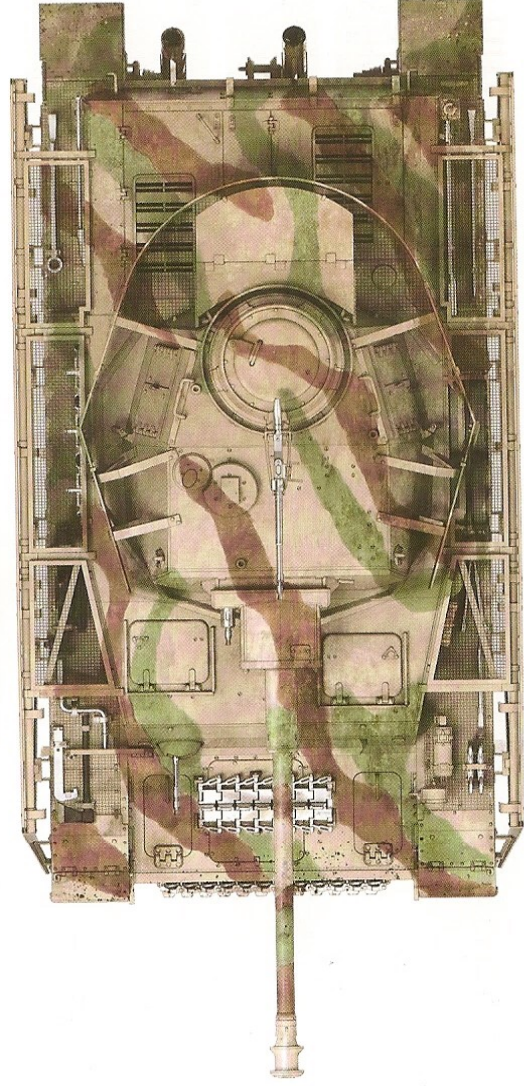

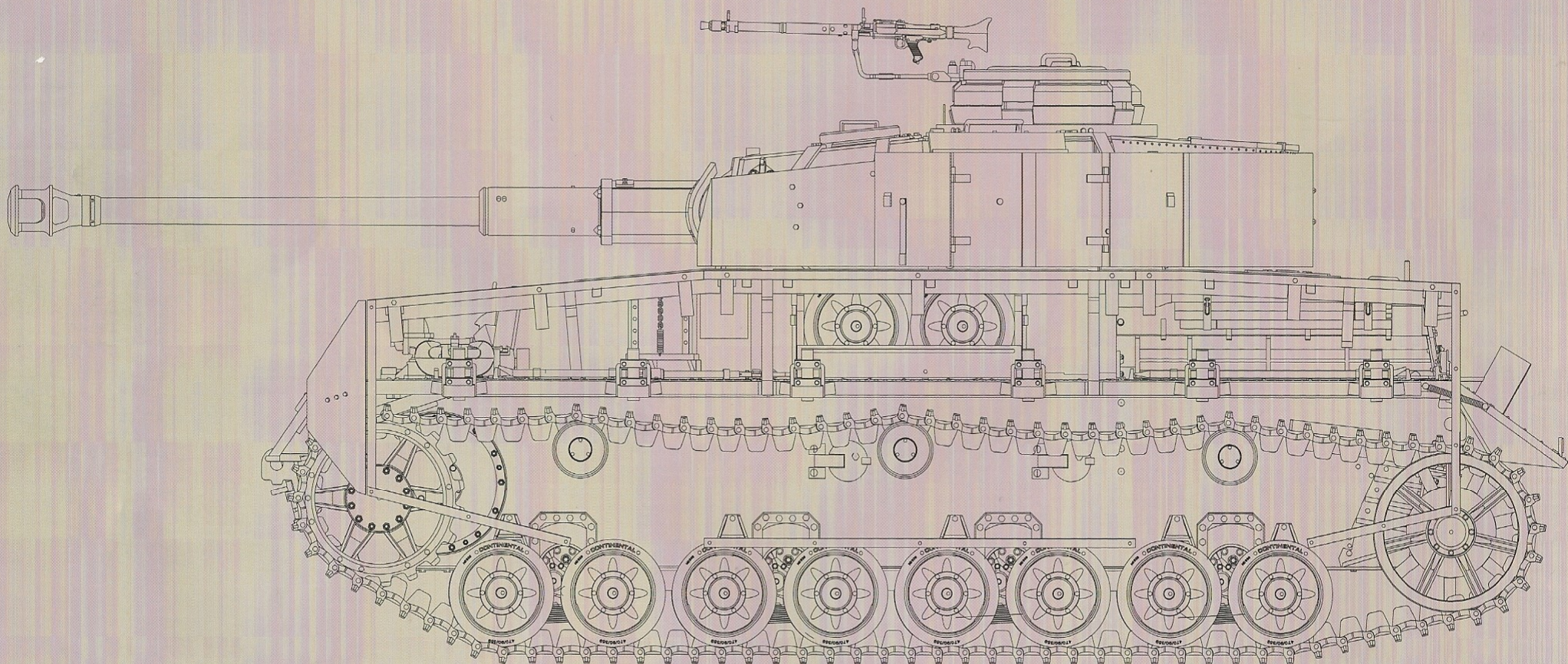

Border