

# Revell A-10 THUNDERBOLT II

4516-3800 -A

The A-10 Thunderbolt II is manufactured by the Fairchild Republic Co. The U.S. Air Force planned it's primary mission for sustained close air support and as a deterrent it was designed to be the most effective aerial tank destroyer in history.

The pilots have affectionately renamed the A-10 the "WARTHOG" based upon it's inherent ugliness. The nickname only refers to the way the plane looks, for the A-10 is an extremely functional aircraft with a mission profile to fly at low levels, feint, mask, attack, withdraw and attack again, making full use of terrain cover.

The A-10 is a very tough airplane with titanium armor for pilot and flight controls, three main wing spars, four self-sealing fuel tanks and the jet engines are protected by armor plating.

## A-10 SPECIFICATIONS

**POWERPLANT** Two TF 34 - GE - 100 Turbofan Engines for a total thrust of 18,000 lbs.  
**LENGTH** ..... 53 feet, 4 inches  
**HEIGHT** ..... 14 feet, 8 inches  
**WINGSPAN** ..... 57 feet, 6 inches  
**ARMAMENT** ..... One 30 mm GAU-8 Seven-Barrel Gatling Gun  
**ORDANANCE CAPACITY** ..... Up to 16,000 lbs. of mixed ordnance  
**MAXIMUM SPEED** ..... With Armament 387 knots

**ENGLISH:** ASSEMBLY DRAWINGS SHOULD BE REVIEWED BEFORE PROCEEDING WITH CONSTRUCTION. A NUMBER IDENTIFIES EACH PLASTIC PART FOR YOUR CONVENIENCE. PAINT SMALL PARTS ON RUNNER BEFORE REMOVING. ALLOW PAINT TO DRY THOROUGHLY BEFORE CONTINUING ASSEMBLY OF KIT. SCRAPE CHROME OR PAINT AT AREA TO BE GLUED. WASH PLASTIC IN MILD DETERGENT SOLUTION. RINSE AND LET AIR DRY FOR BETTER PAINT AND DECAL ADHESION.

**DEUTSCH:** VOR DEM ZUSAMMENBAU DIE BAUANLEITUNG GUT DURCHLESEN. JEDES TEIL IST NUMMIERT. KLEINE TEILE ANSTREICHEN BEVOR SIE VOM RAHMEN ENTFERNT WERDEN. FARBEN GUT TROCKNEN, ERST DANN MIT DER ZUSAMMENSTELLUNG FORTSETZEN. CHROM UND FARBE AN DEN KLEBEFLÄCHEN ENTFERNEN. PLASTIKTEILE IN EINER MILDEN WASCHMITTELLOESUNG REINIGEN UND AN DER LUFT TROCKNEN. DAMIT FARBE UND ABZIEHBILDER BESSER HAFTEN.

**FRANCAIS:** EXAMINER LES SCHEMAS D'ASSEMBLAGE AVANT DE COMMENCER LA CONSTRUCTION. UN NUMERO IDENTIFIE CHAQUE PIECE DE PLASTIQUE POUR PLUS DE FACILITE. PEINDRE LES PETITES PEICES SUR LE SUPPORT AVANT DE LES ENLEVER. LAISSER LA PEINTURE SECHER COMPLETEMENT AVANT DE CONTINUER L'ASSEMBLAGE DU KIT. GRATTER LE CHROME OU LA PEINTURE SUR LES SURFACE A COLLER. LAYER LE PLASTIQUE DANS UNE SOLUTION DE DETERGENT LEGERE, RINCER ET LAISSER SECHER A L'AIR POUR UNE MEILLEURE ADHERENCE DE LA PEINTURE ET DES DECALS.

**NEDERLANDS:** BESTUDEER DE MONTAGE TEKENINGEN. VOORDAT U MET BOUWEN BEGINT. VOOR UW GEMAK. IDENTIFICEERT EEN NUMMER ELK PLASTIC DEEL. VERF KLEINE DEELTJES OP KIBOOM VOORDAT U ZE VERWYDERD. LAAT VERF GRONDIG DROGEN VOORDAT U DE MONTAGE VAN HET MODEL VOORTZET. SCHRAP CHROOM OF VERF VAN HET GEDEELTE DAT GELYMD WORDT. WAS PLASTIC MET EEN ZACHTE ZEEP. SPOEL AF, EN LAAT IN LUCHT DROGEN, ZODAT VERF EN DECAL BETER PLAKKEN.

**SVENSKA:** IHOPSATTNINGSSKISSEN BOR GRANSKAS INNAN IGANGSATTANDE AV BYGGANDET. ETT NUMMER IDENTIFIKERAS VARJE PLASTDEL FOR DIN EGEN BEKVAMLIGH ET. MALA DE SMA BITARNA DIREKT PA FARAN INNAN DE TAS BORT. LAT FARGEN TORKA GRUNDLIGT INNAN FORTSATT BYGGANDE. SKRAPA AV KROMEN ELLER MALA PA DELARNNA SOM SKALL KLISTRAS. TVATTA PLASTEN I MILD TVATTMEDELLOSNING, SKOJ OCH LUFTTORKA FOR BATTRE FASTANDE AV FARG OCH DEKALER.

**ESPAÑOL:** DIBUJOS DE ENSAMBLAJE DEBEN SER REPASADOS ANTES DE SEGUIR CON LA CONSTRUCCION. UN NUMERO IDENTIFICA CADA PARTE DEL PLASTICO PARA SU CONVENIENCIA. PINTÉ PARTES PEQUEÑAS DEL KIT ANTES DE QUITARLAS. DEJE SECAR BIEN LA PINTURA ANTES DE SEGUIR EL ENSAMBLAJE. RASPE EL CROMO O LA PINTURA DEL SITIO ANTES DE SER PEGADO. LAVE EL PLASTICO EN UNA SOLUCION SUAVE DETERGENTE, ENJUAGUE, Y DEJE SECAR EN EL AIRE PARA MEJOR ADHESION DE LA PINTURA Y CALCOMANIA.

**ITALIANO:** I DISEGNI DELL'ASSEMBLAGGIO DOVREBBERO ESSERE RICONTROLLATI PRIMA DI INIZIARE IL MONTAGGIO. OGNI PEZZO E IDENTIFICATO DA UN NUMERO PER VOSTRA MAGGIORE COMODITA. VERNICIARE LE PARTI PICCOLE SULLA GUIDA DE SCORRIMENTO PRIMA DE TOGLIERLE. LASCIAR ASCIUGARE LA VERNICE PRIMA DI CONTINUARE IL MONTAGGIO. RASCHIAR LA PITTURA O IL CROMO DALLE PARTI CHE DEVONO ESSERE INCOLLATE. LAVARE I PEZZI DI PLASTICA CON UN DETERGENTE NON TROPPO FORTE. SCIAQUARE E LASCIAR ASCIUGARE AFFINCHÉ VERNICE E DECALCOMANIE ADERISCAHO MEGLIO.



GLUE  
KLEBER  
COLLE  
LIJM  
KLISTER  
PEGA  
COLLA



NO GLUE REQUIRED  
KEIN KLEBER NOTWENDIG  
LA COLLE N'EST PAS NECESSAIRE  
GEEN LIJM NODIG  
INGET KLISTER BEHOVS  
NO NECESITA PEGA  
NON C'E BISOGNO DI COLLA



DO IT THIS MANY TIMES  
ANZAHL DER ARBEITSGRENZE  
LE FAIRE CE NOMBRE DE FOIS  
DOE HET ZOVEEL KEER  
GJOR DET SA MANGA GANGER  
FATELO TUTTE QUESTA VOLTE  
HAGALO ESTA CANTIDAD DE VECES



OPTIONAL  
WAHLWEISE  
FACULTATIF  
NAAR KEUZE  
VALFRI  
FACOLTATIVO  
OPCIONAL



APPLY DECALS  
ABZIEHBILDER ANBRINGEN  
COLLER LES DECALCOMANIES  
BRENG PLAKPLAATJES AAN  
SATT PA DEKALERNA  
APPLICARE LE DECALOMANIE (ADESIVI)  
APLICAR CALCAS



SHOWN ASSEMBLED  
ABBILDUNG DES ZUSAMMEN GEBAUTEN MODELLS  
VU ASSEMBLE  
GEMONTEERD GETOOND  
VISAD IHOPSATTNING  
MOSTRADO ARMADO  
II LUSTRAZIONE DEL PEZZO MONTATO



CLEAR  
KLAR  
TRANSPARENT  
DOORZICHTIG  
KLART  
VIA LEBERA  
TRANSPARENTE



MATT LIGHT OLIVE  
MATT OLIV-HELL  
OLIVE CLAIR MAT  
MAT LICHT OLIJF  
MATT LJUS OLIVAGRÖN  
MATE VFRDE OLIVO CI ARO  
VERDE CI IV4 CHIARO SMORTO

<b>A</b> MATT BLACK	MATT SCHWARZ	NOIR MAT	MAT ZWART	MATT SVART	NEGRO MATE	NERO SMORTO
<b>B</b> GLOSS WHITE	GLANS WEISS	BLANC VERNIS	GLANS WIT	GLANS VIT	BRILLANTE BLANCO	VERNICE LUCIDA BIANCO
<b>C</b> DARK GRAY	DUNKELGRAU	GRIS FONCE	DONKER GRIJS	MORKGRA	GRIS OSCURO	GRIGIO SCURO
<b>D</b> DARK GREEN	DUNKELGRUEN	VERT FONCE	DONKER GROEN	MORKGRON	VERDE OSCURO	VERDE SCURO
<b>E</b> MATT IRON GREY	MATT EISENGRAU	GRIS DE FER MAT	MAT IJZERGRUIS	JARNGRA	GRIS HIERRO MATE	GRIGIO FERRO SMORTO
<b>F</b> YELLOW	GELB	JAUME	GEEL	GUL	AMARILLO	GIALLO
<b>G</b> LIGHT OLIVE	OLIV-HELL	OLIVE CLAIR	LICHT OLIJF	LJUS OLIVAGRON	VERDE OLIVO CLARO	VERDE OLIVA CHIARO

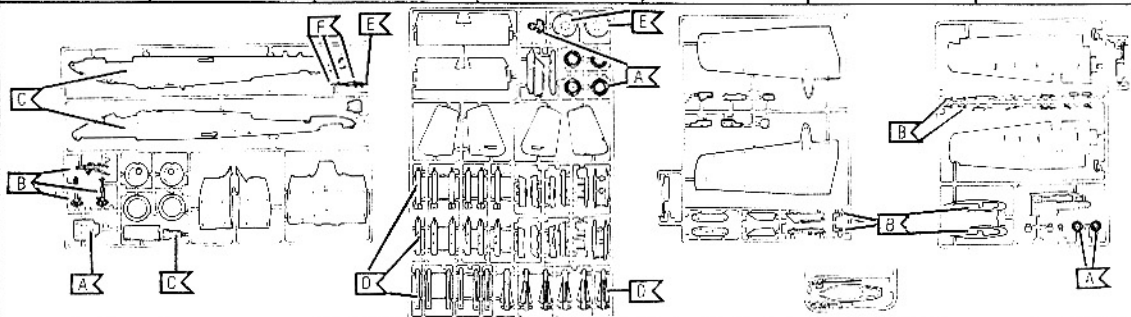
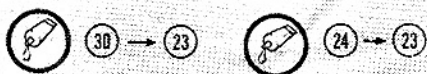
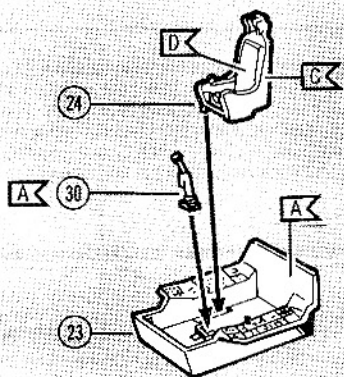
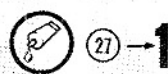
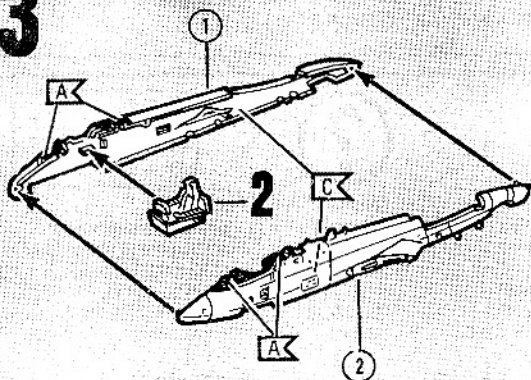
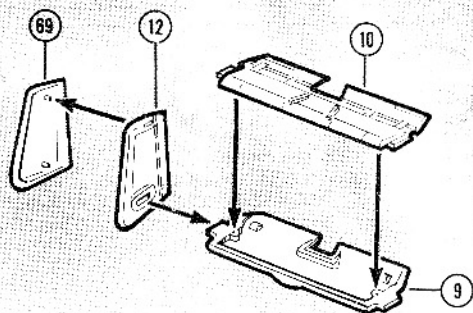
**1****2****3****4**

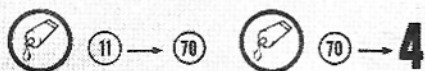
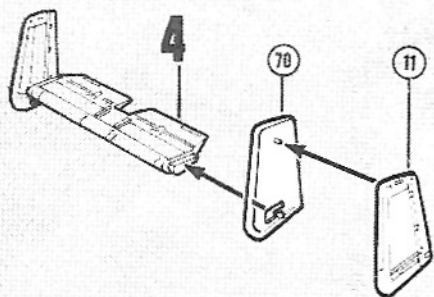
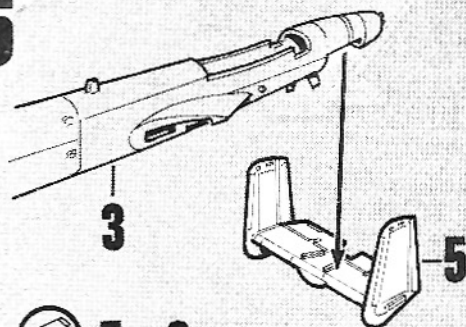
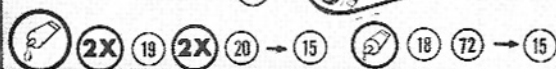
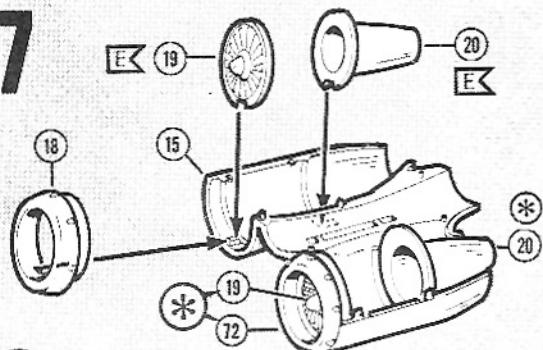
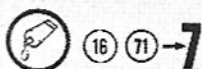
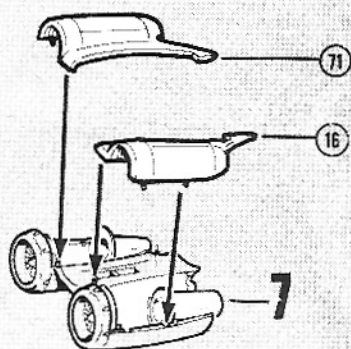
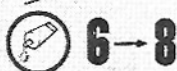
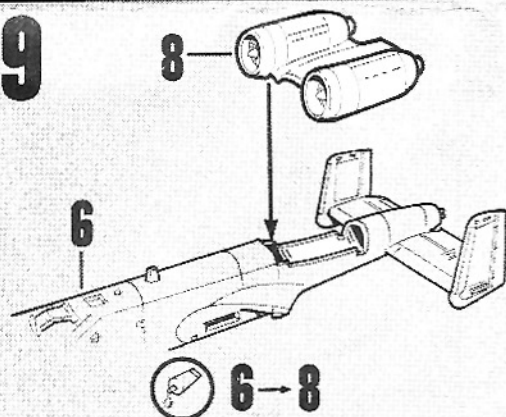
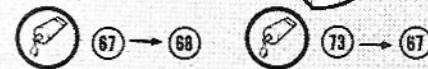
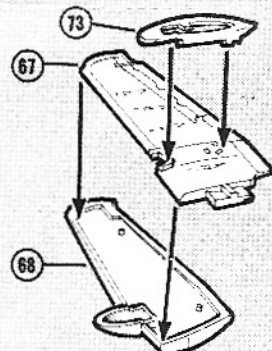
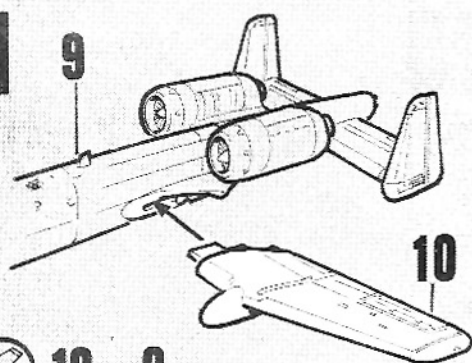
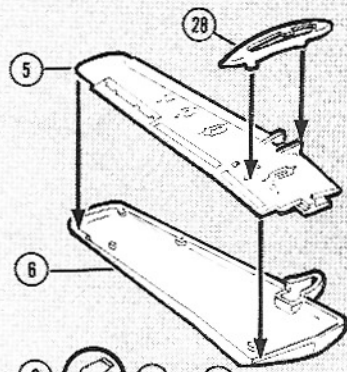
**5****6****7****8****9****10****11****12**

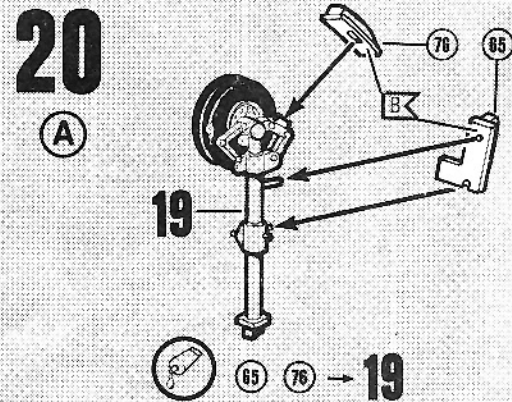
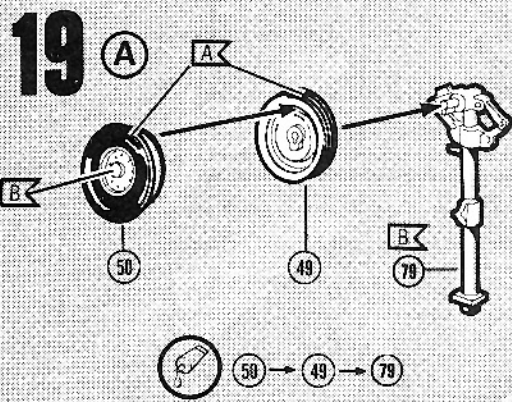
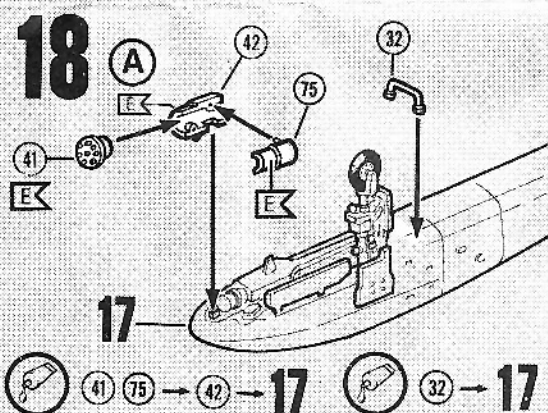
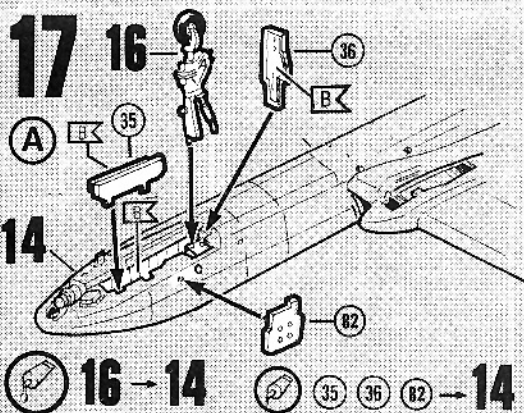
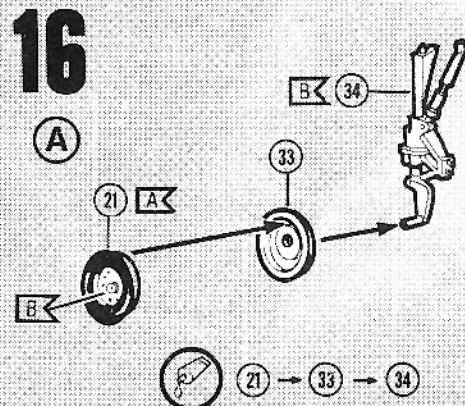
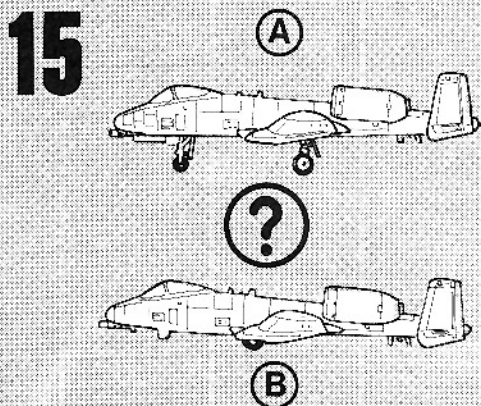
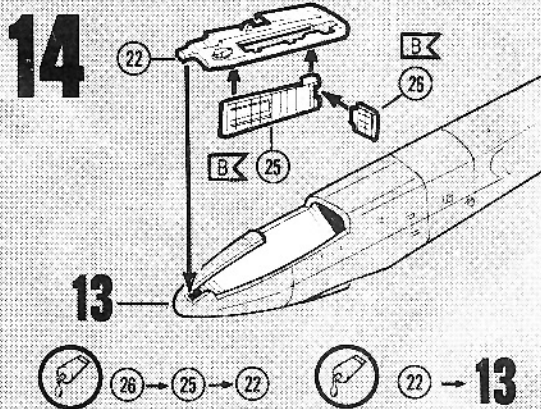
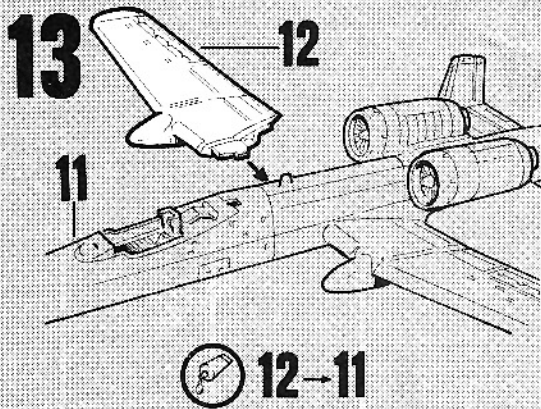

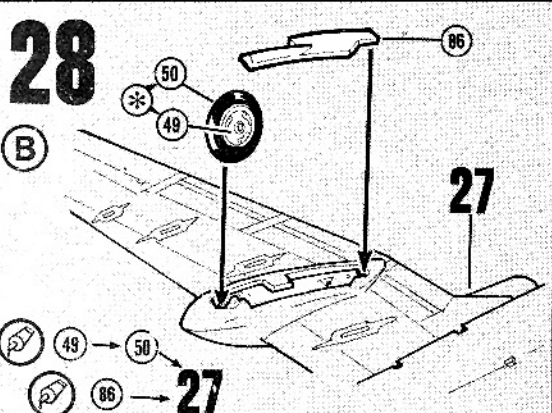
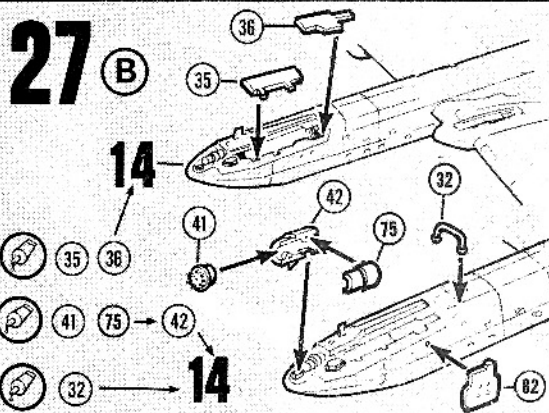
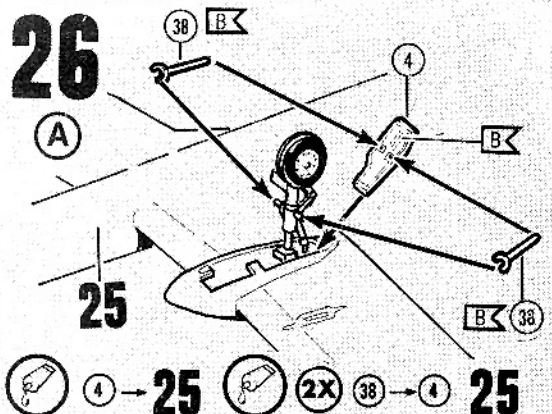
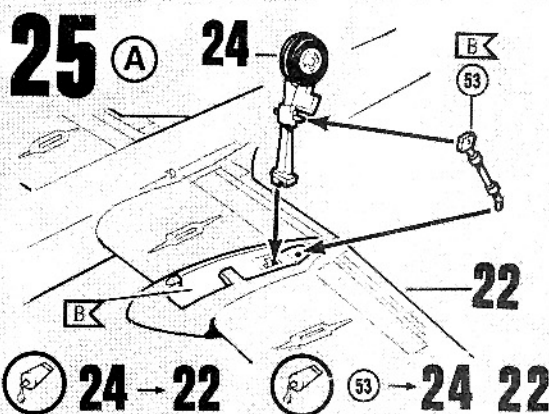
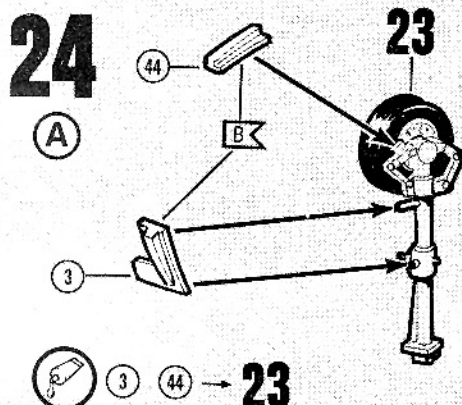
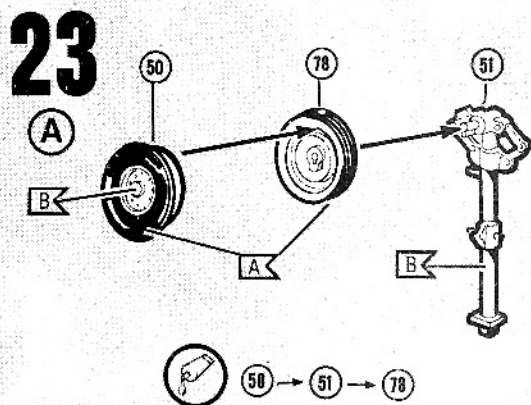
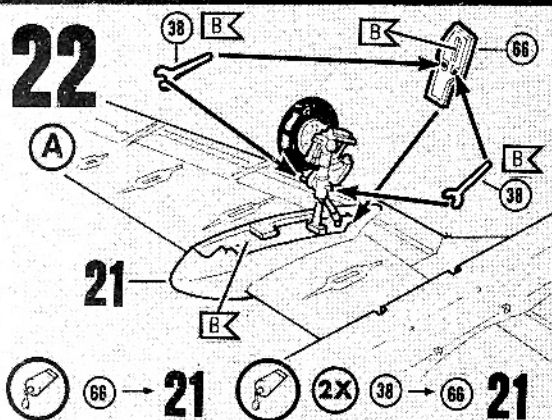
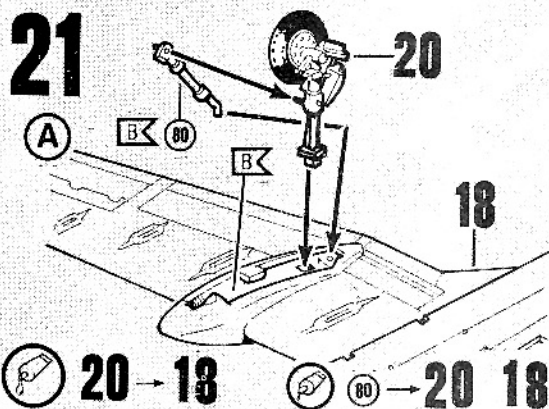

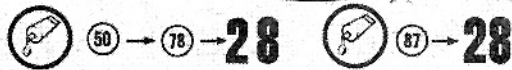
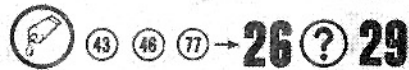
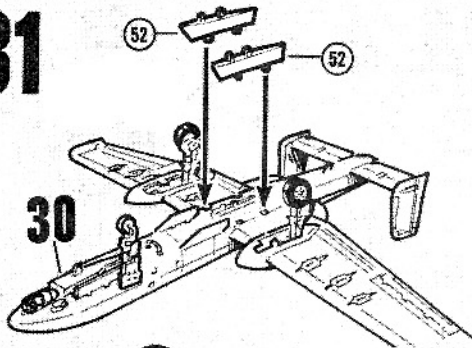
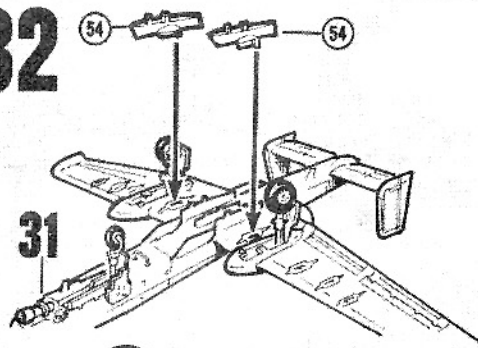
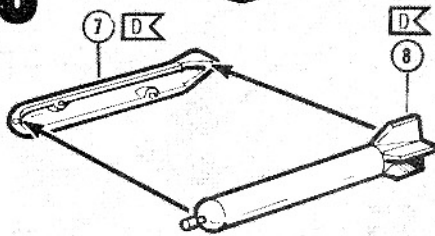
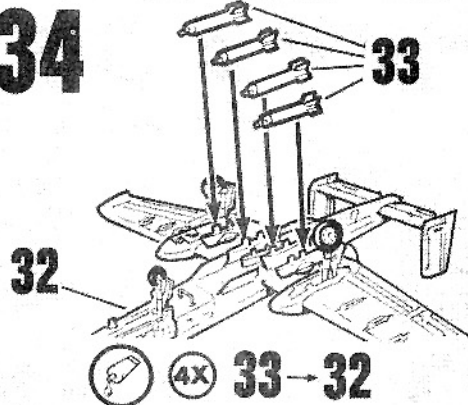
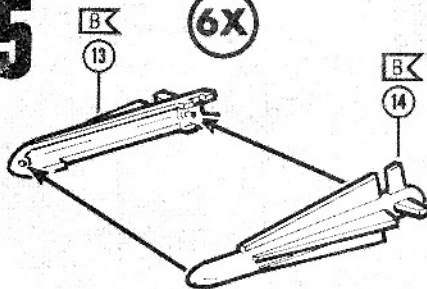
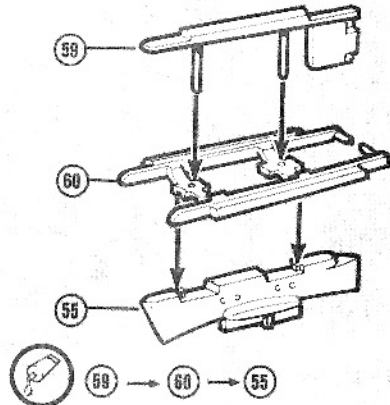
**29****B****28****30****29****31****32****33****6X****34****35****6X****36****2X**

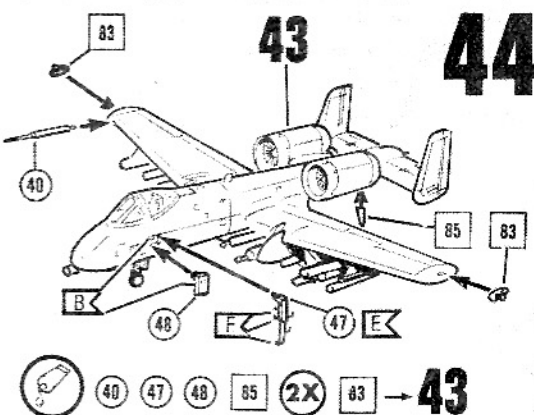
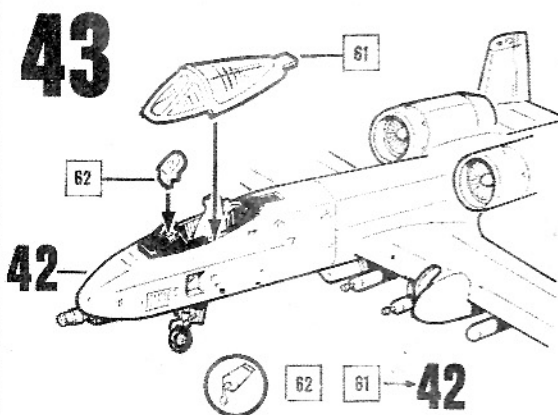
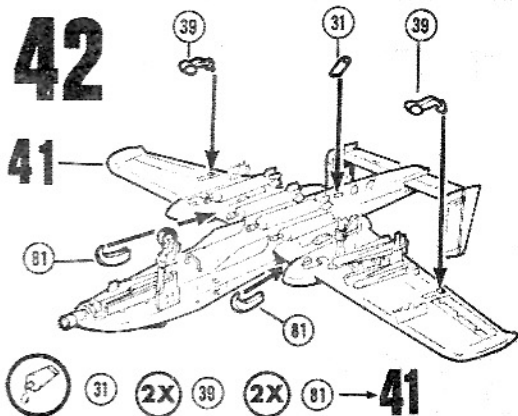
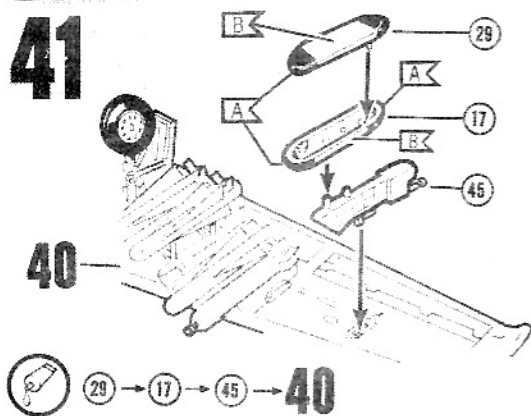
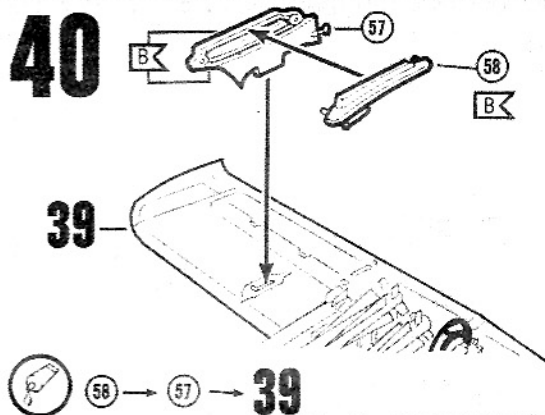
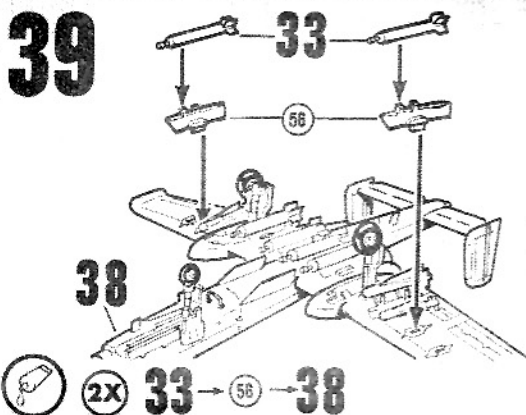
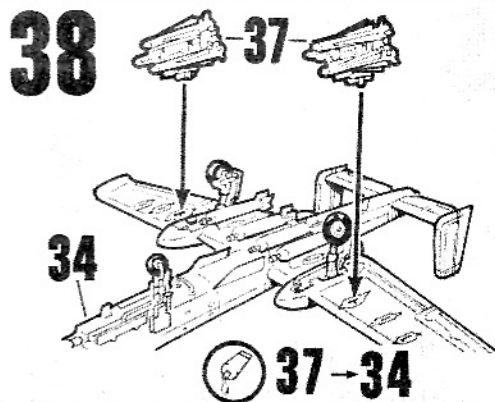
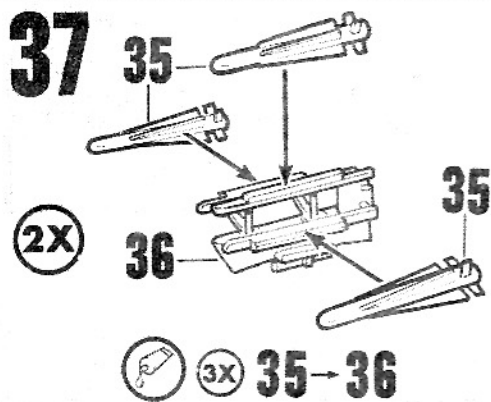

# 45

WR WR  
#255 #255

© REVELL, INC. 4516

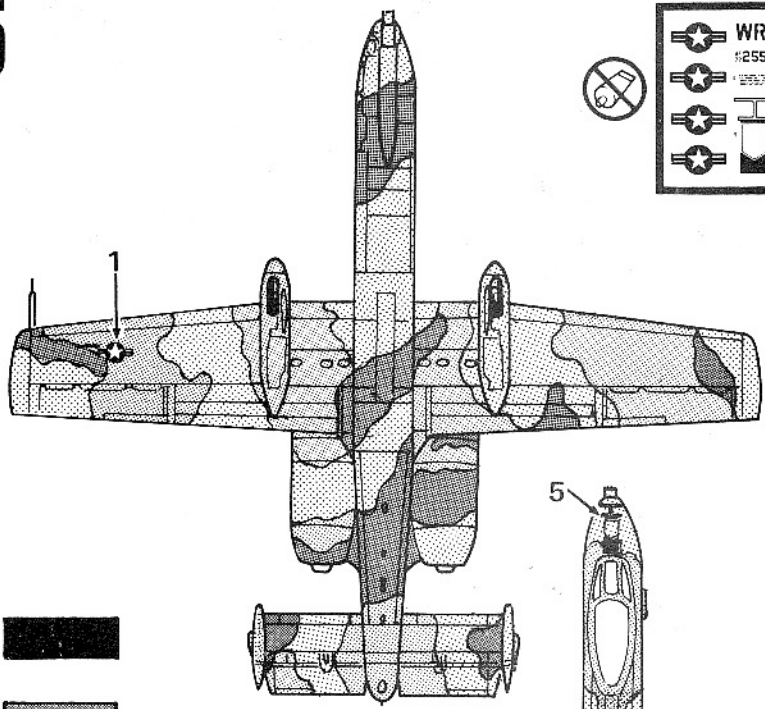

- A**
- C**
- D**
- G**

