



German Pzkw IV Ausf. J Medium Tank

德国四号J型中型坦克

READ BEFORE ASSEMBLY:

- This kit is not recommended for inexperienced modelers or for children under 14 years of age
- Study and understand these instructions thoroughly before beginning assembly
- When needed, remove photo-etch parts carefully using a modeling knife or photo etch sprue cutter, being careful not to damage or lose small parts.
- Take extra care in handling photo etch parts in order to avoid injury
- Apply instant cement sparingly to photo etch parts where instructed
- Tools recommended(not included in kit):Plastic and instant cements,sprue cutters,long nose pliers,modeling knife, small files, tweezers, pin vise & scissors. Soft cloth and sandpaper will also assist in construction
- Glue and paint are not included in the kit. Use plastic cement and hobby paints only. Color guide for purchasing paint is included in the kit.
- Keep out of reach of children. They must not be allowed to ingest small parts or handle plastic bags in any way.

装配之前仔细阅读

- 小心用模型锉刀锉平所有零件表面的注射浇口。
- 小心用刀片切下蚀刻片零件，不要遗失小零件。
- 用强力快干胶水粘合蚀刻片零件和金属轴。过量的快干胶水使用可能导致可动零件会粘住，小心涂胶。
- 取蚀刻片时应特别注意安全，防止利边划伤手指。
- 某些零件表面需贴水上贴纸，请选择在装配的同时进行。
- 推荐模型工具(自备)：胶水，水口剪刀，长咀钳，刀片，锉刀，镊子钳，钻，剪刀，瞬间快干胶。
- 软布同砂纸同时也应该是必备工具。
- 请使用塑料胶水和油漆，模型内不含。
- 谨防小孩吸吮塑料零件，或者将塑料袋套在头上，制作时应将套材远离小孩接触。
- 本产品不适合14岁以下没有经验的模型爱好者。

水贴纸的使用:

1. 从水贴纸上剪下印花;
2. 将印花放入温水中浸10秒, 然后放在干净布上.
3. 拿着印花纸板将印花移到模型上;
4. 手指蘸水将印花移到适当的位置;
5. 用软布轻压印花直至水干, 气泡消失.

DECAL APPLICATION:

1. Cut decals from sheet as needed
2. Dip the decal in warm water for about 10 seconds and then place on soft clean cloth.
3. Hold the decal backing sheet edge and gently slide the decal onto the model in its proper position.
4. While still wet, decal can be adjusted for better fit on model by dampening it gently with your finger.
5. When placed in the proper position, gently press decal down with a soft cloth until excess water and air bubbles are gone.
6. Allow decal to dry completely before handling model



部品图 Parts

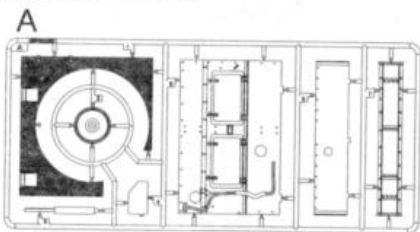

A8

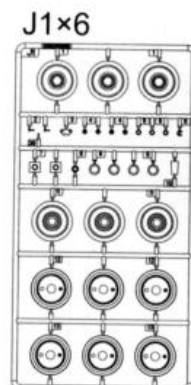
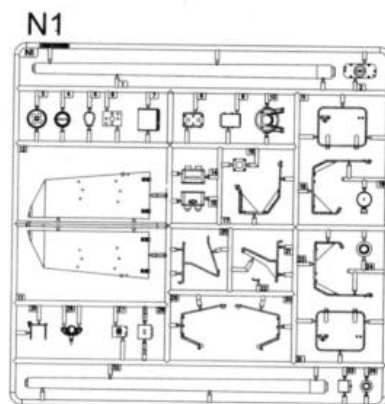
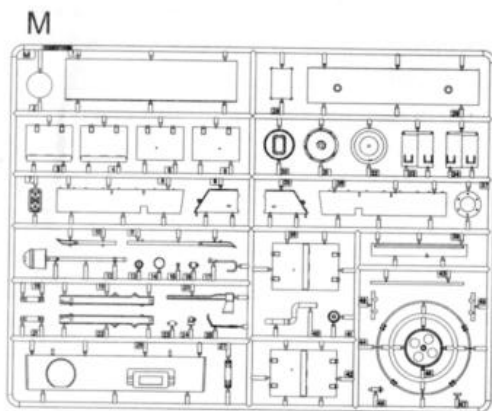
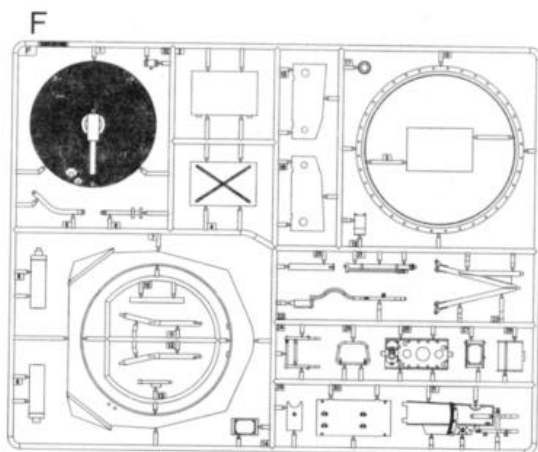
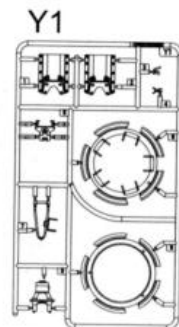
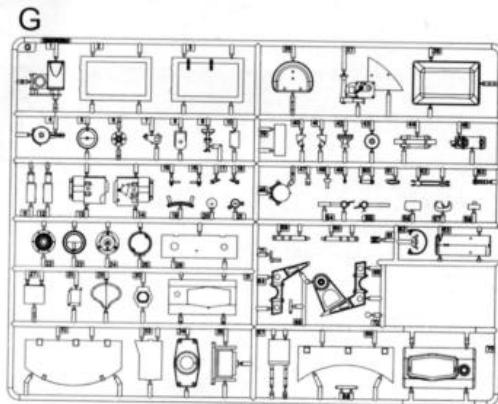
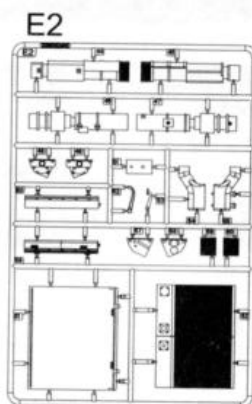
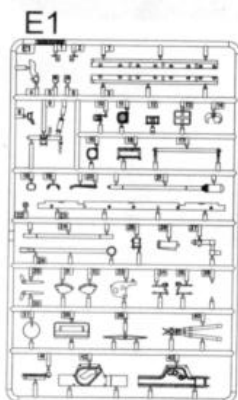
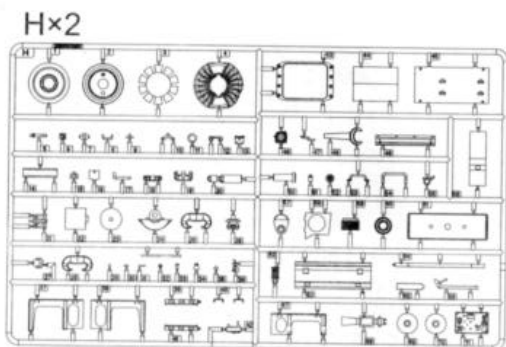
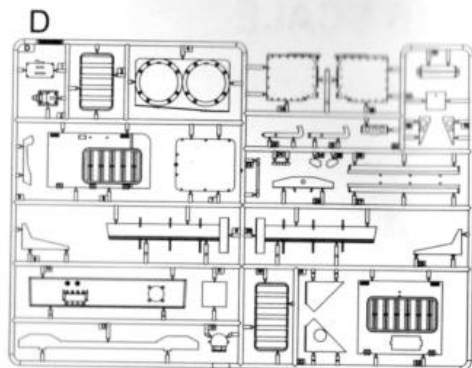
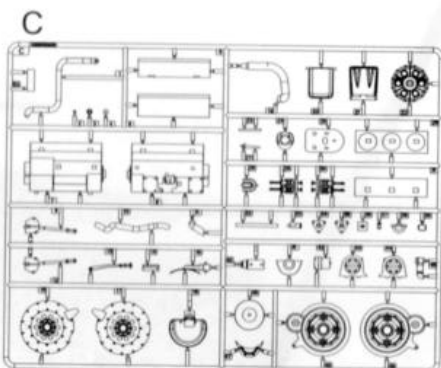
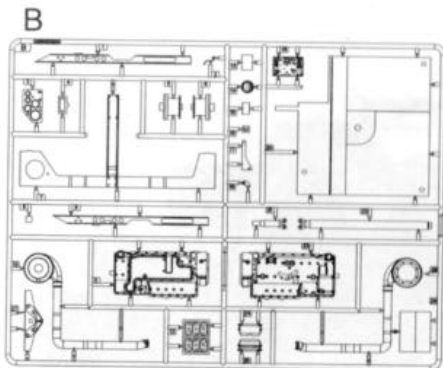
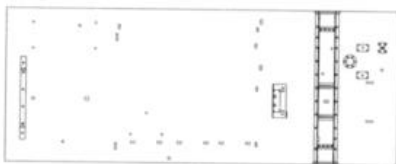

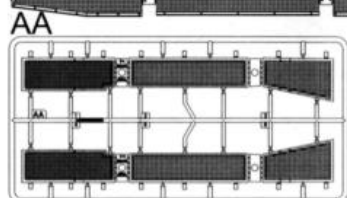
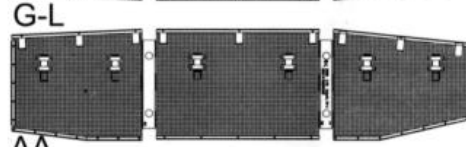
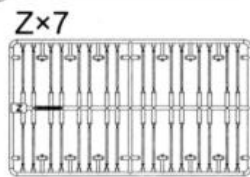
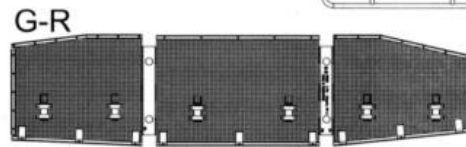
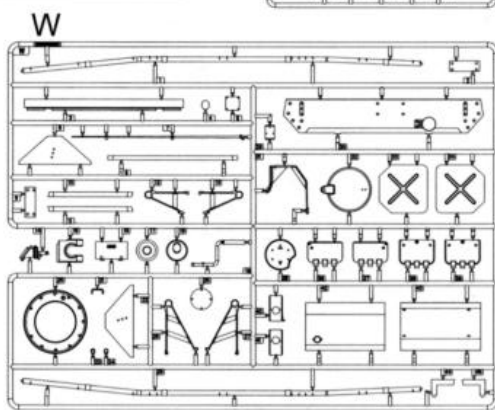
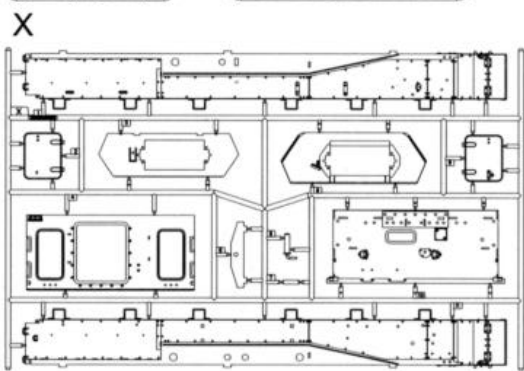
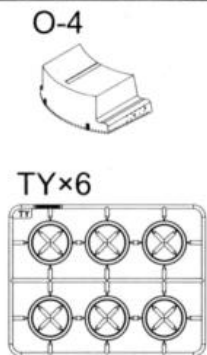
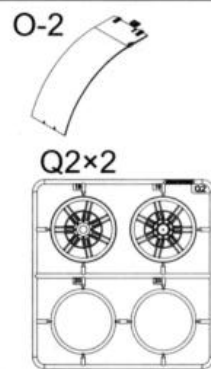
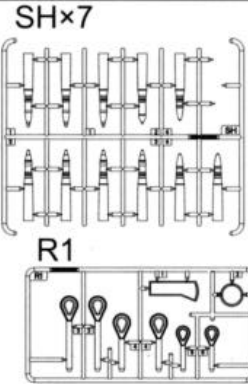
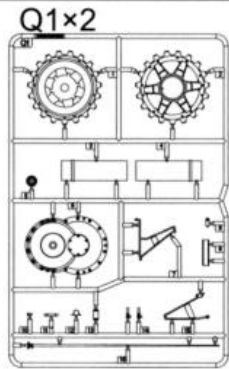
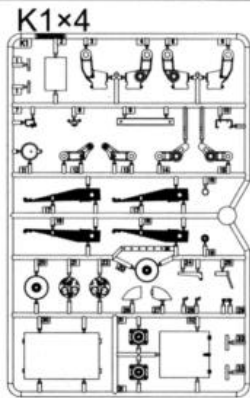
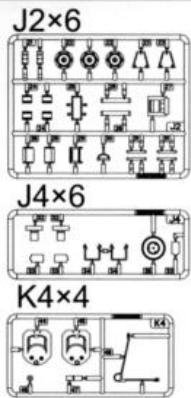

《金属轴》
Metal axes x2

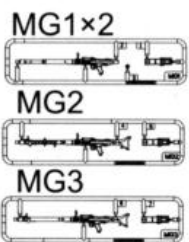
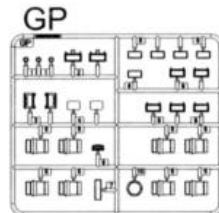

《炮塔》
Turret

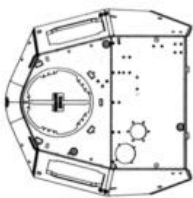

《蚀刻片A》
PE-A

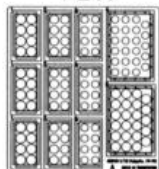

《蚀刻片B》
PE-B

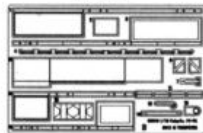

《蚀刻片C》
PE-C

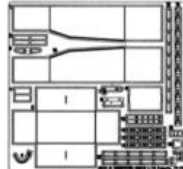

《蚀刻片D》
PE-D x2



《蚀刻片F》
PE-F

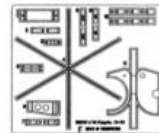

《蚀刻片J》
PE-J

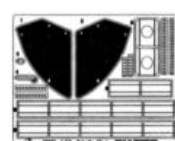

《蚀刻片K》
PE-K

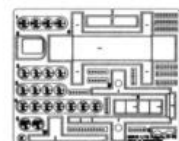

《金属炮管》
Metal gun barrel



《车面》
Upper hull

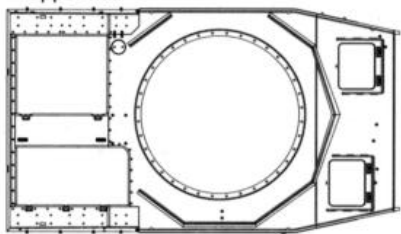

《车底》
Lower hull

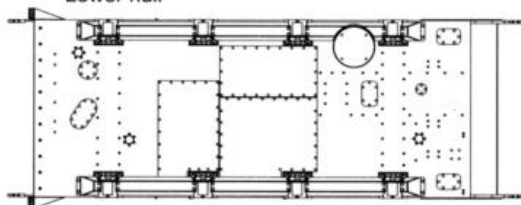

《长弹簧》
Long spring x2



《短弹簧》
Short spring x2



《铜缆》 \varnothing 1.5x700mm
Brass wire



《水贴》Decal A



《水贴》Decal B



不用部品: M1 M7 M13 M14 M16 M17 M19 M22 M23 M24 M28 M31 M32 M33 M34 M40
Unused parts M41 M45 M46 N3 N5 N8 N9 N14 N15 N27 N28 N34 Q9 Q10 PE-F1 PE-F11

1

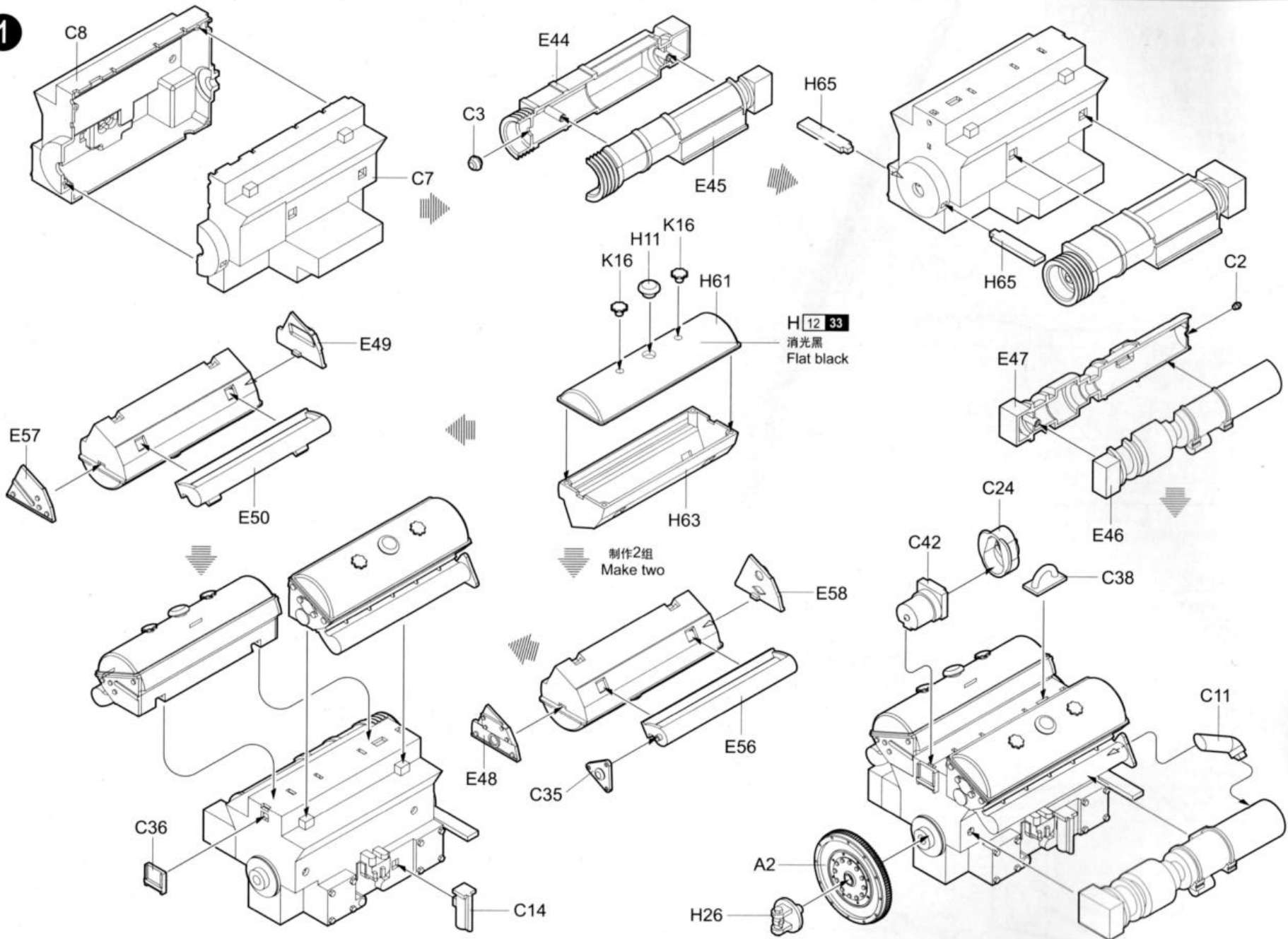

2

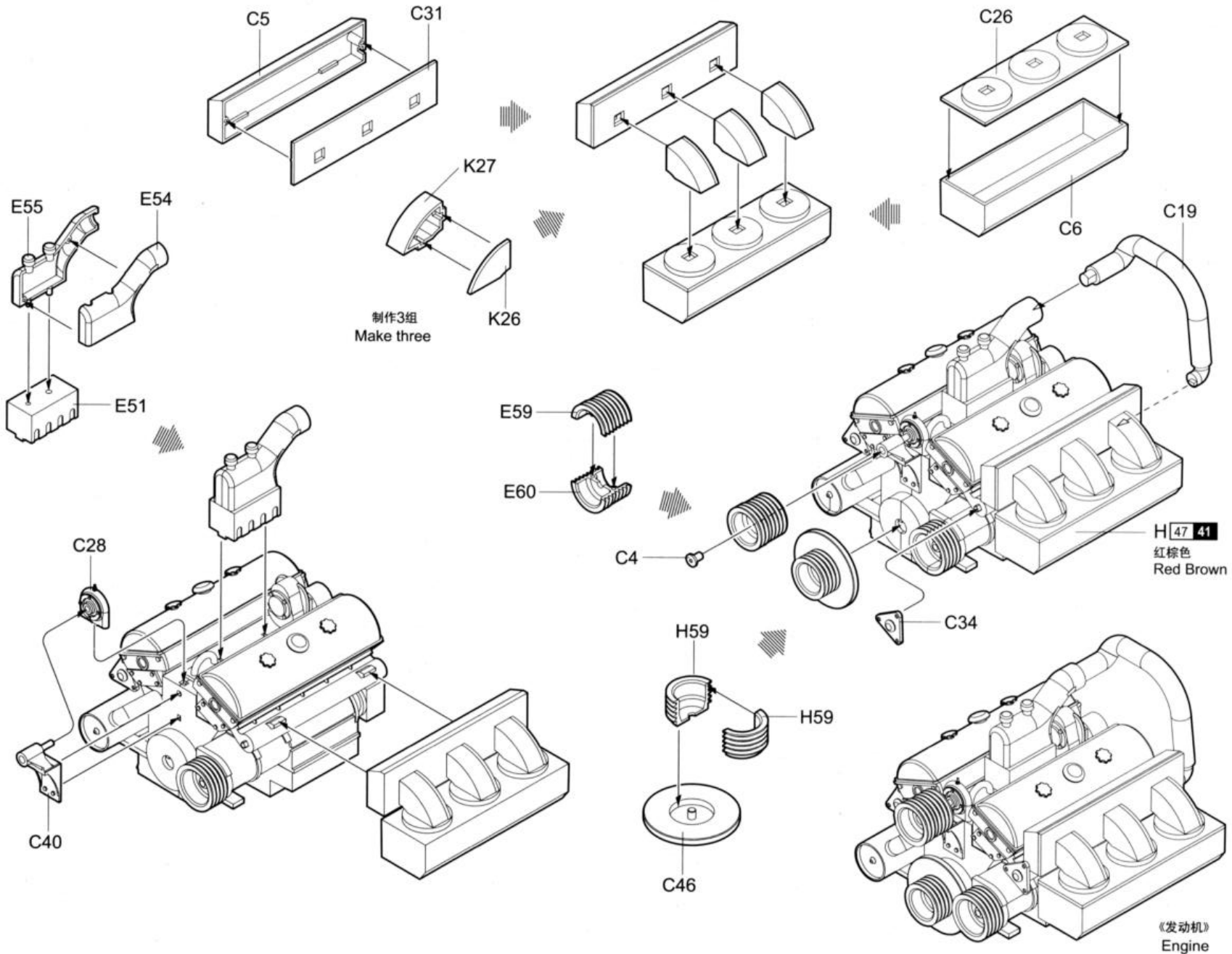

3

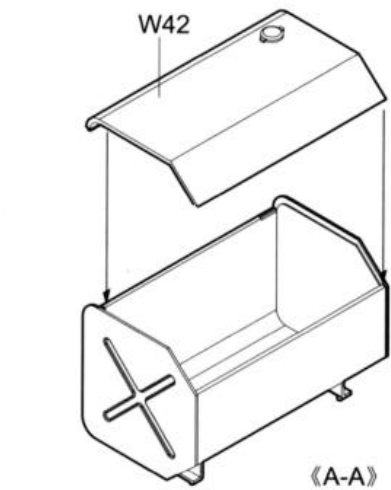
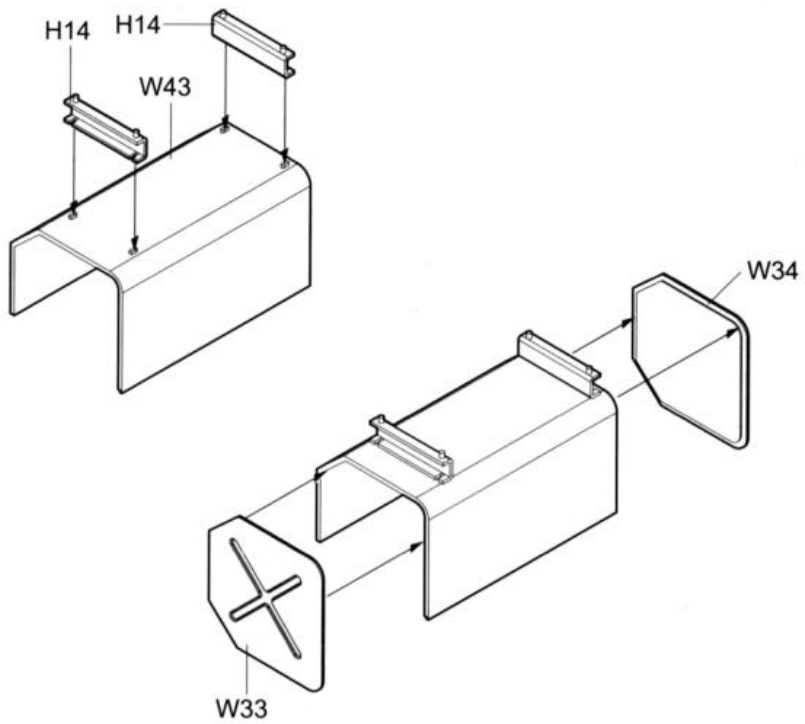

《A-A》

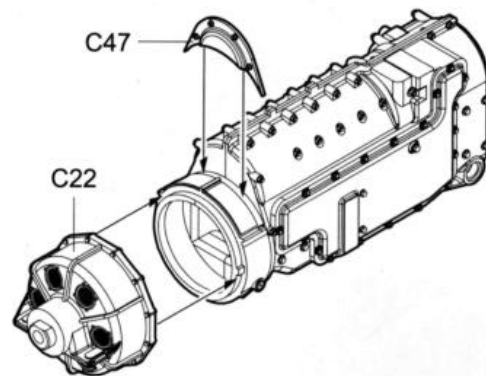
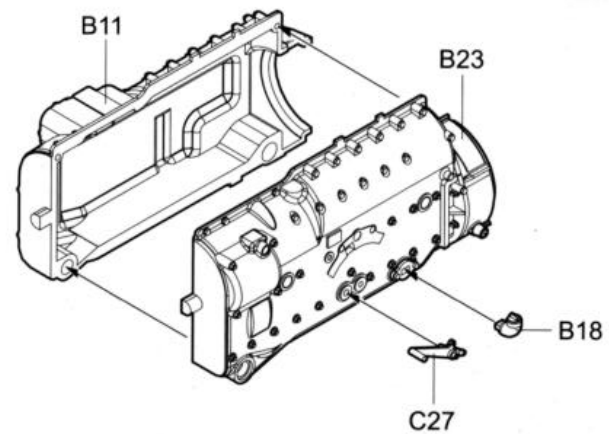

4

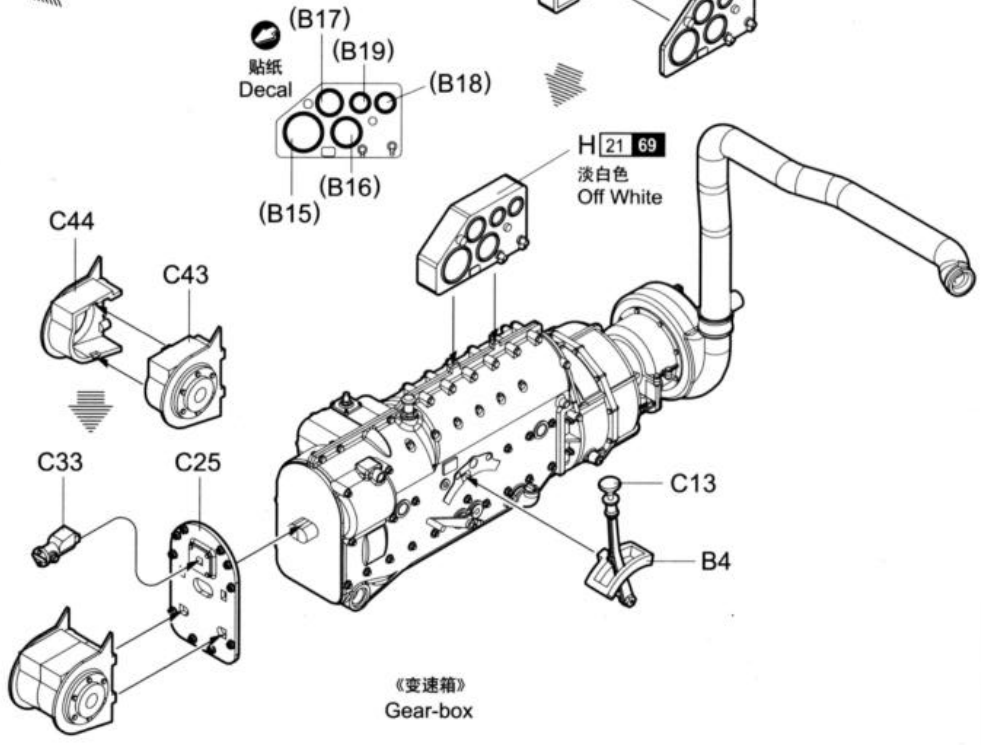
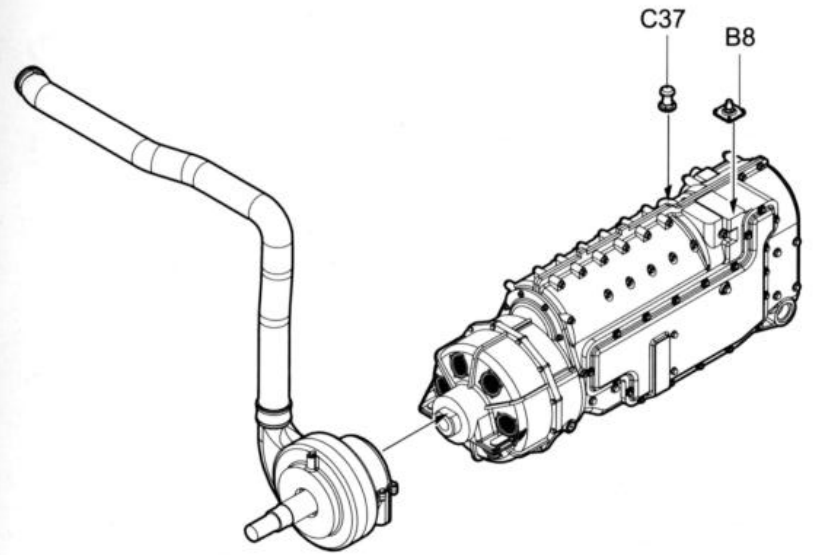
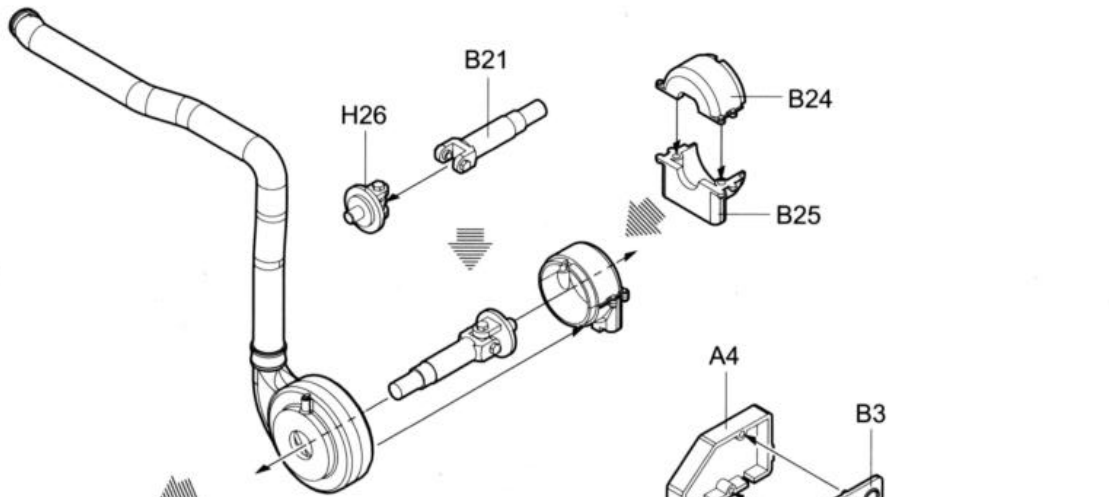
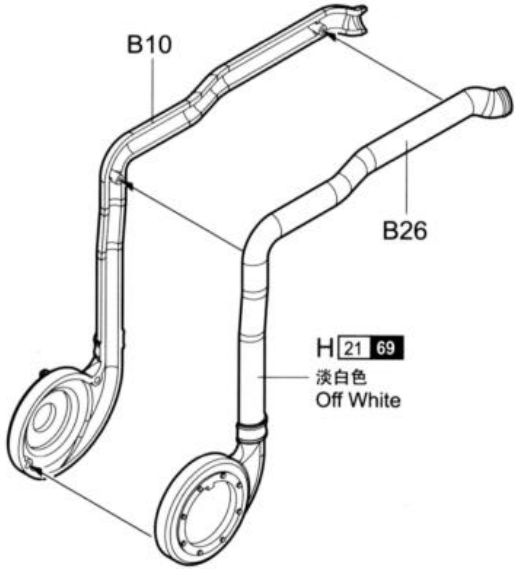

5

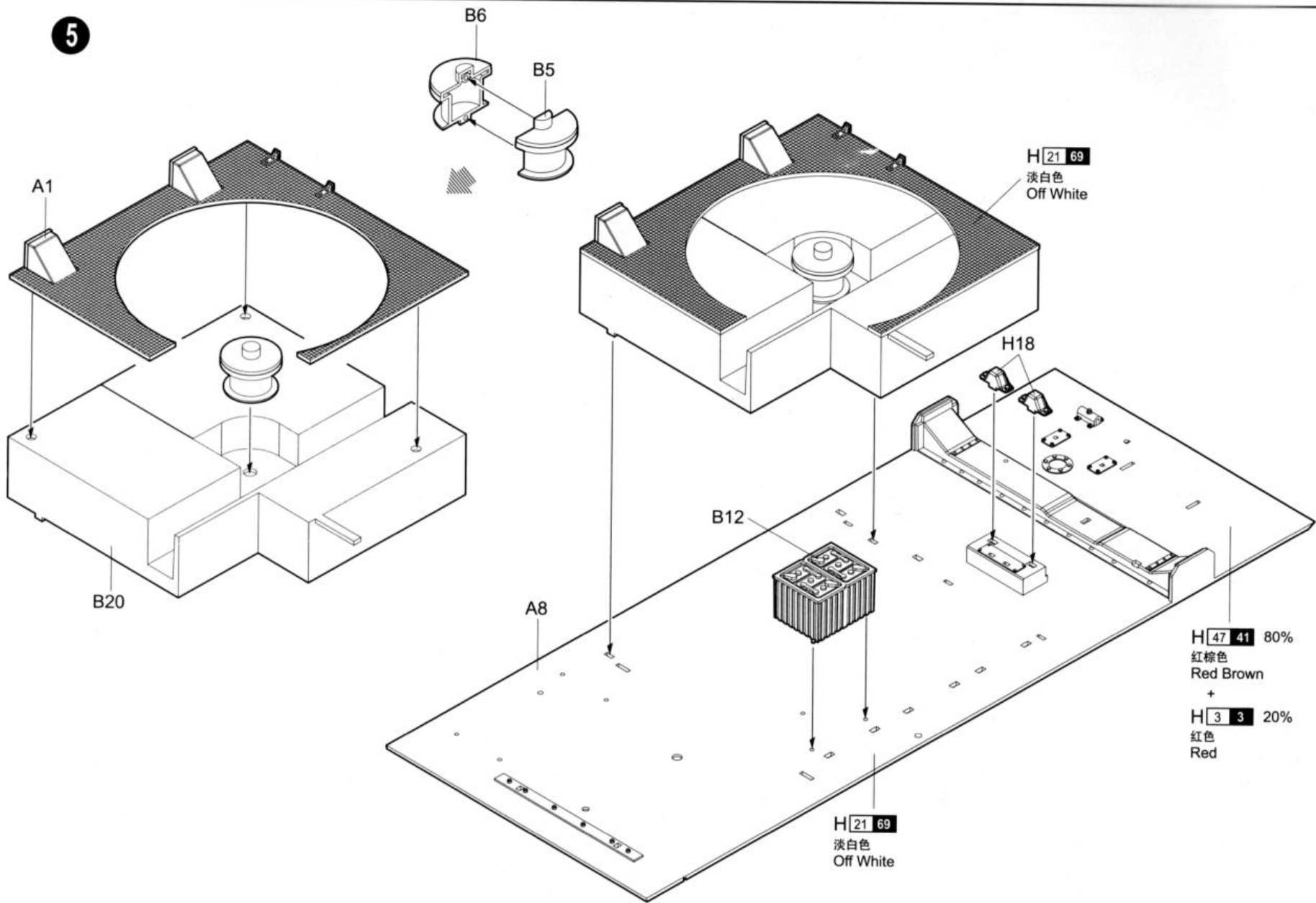

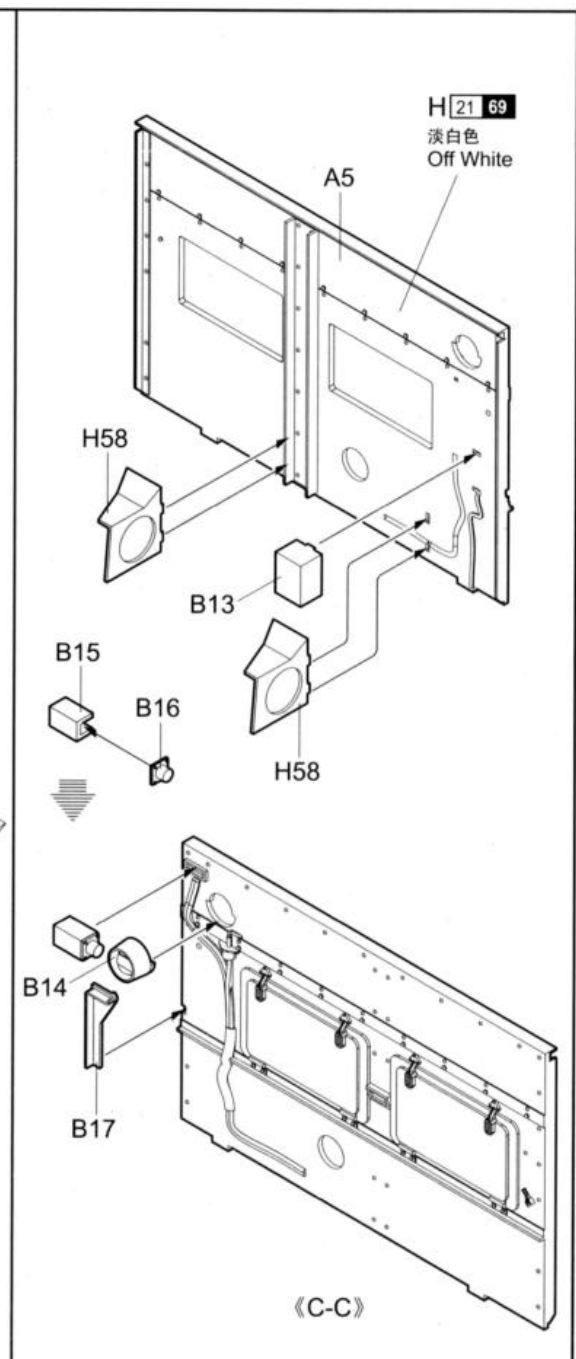
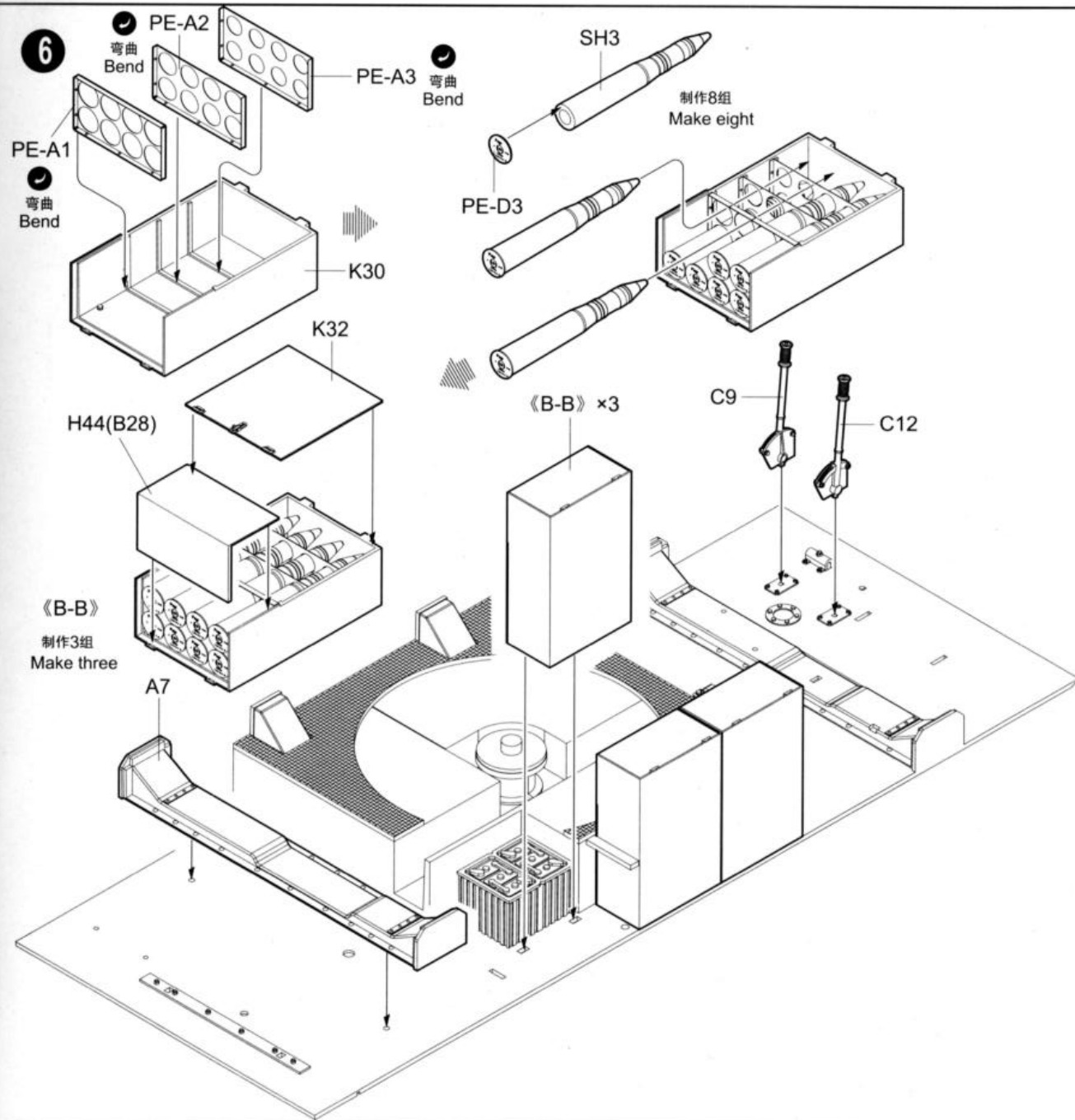

7

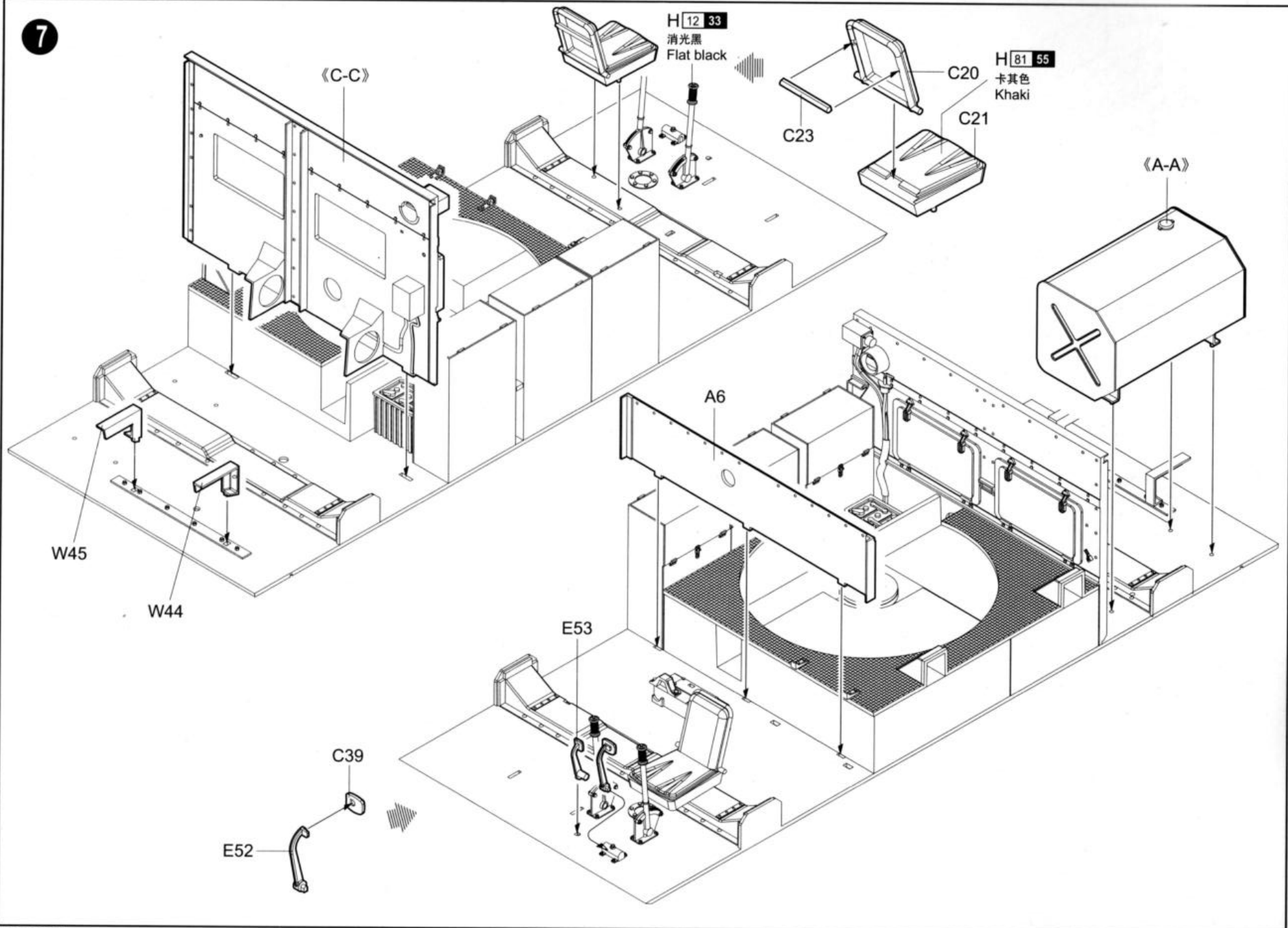

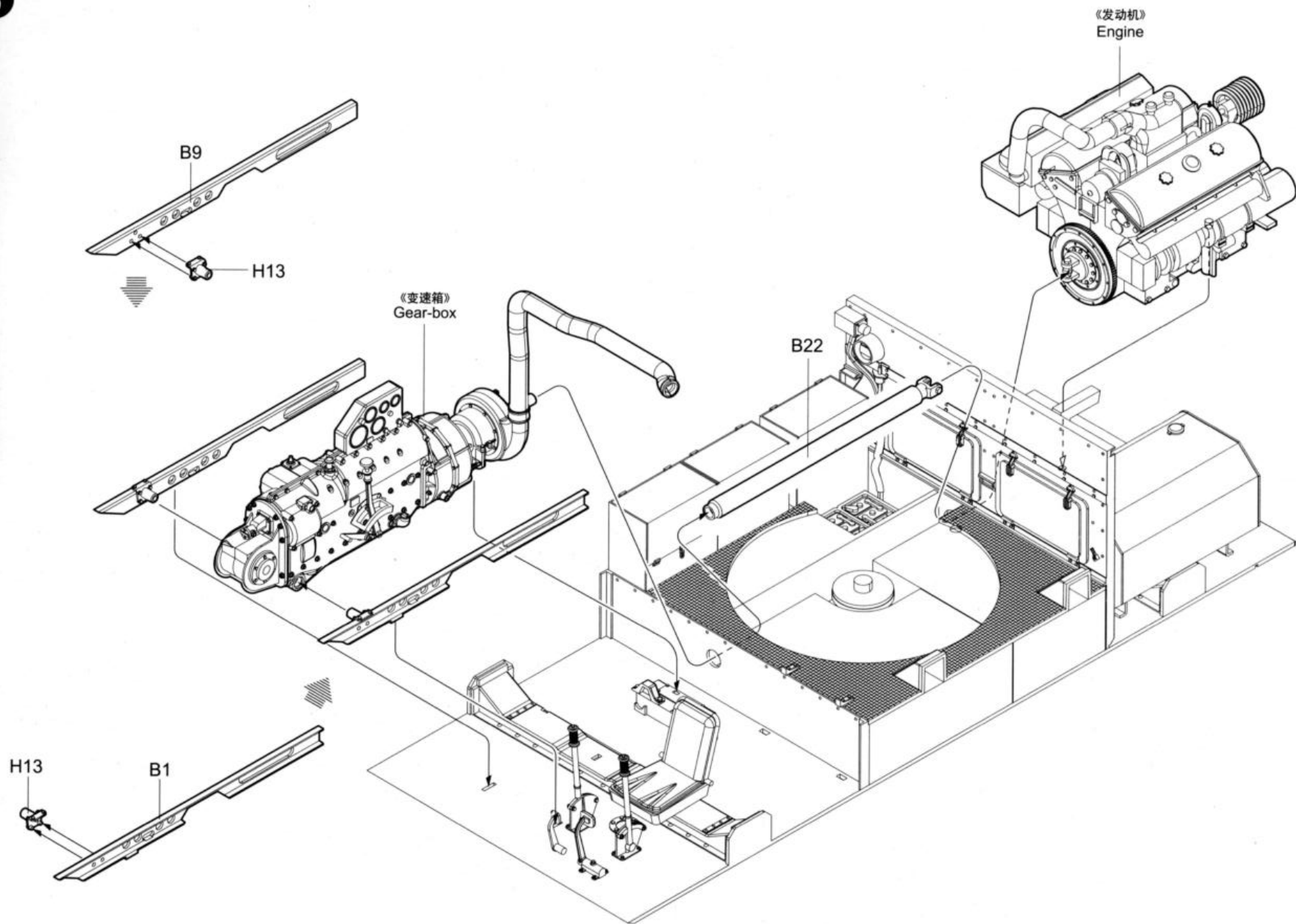

9

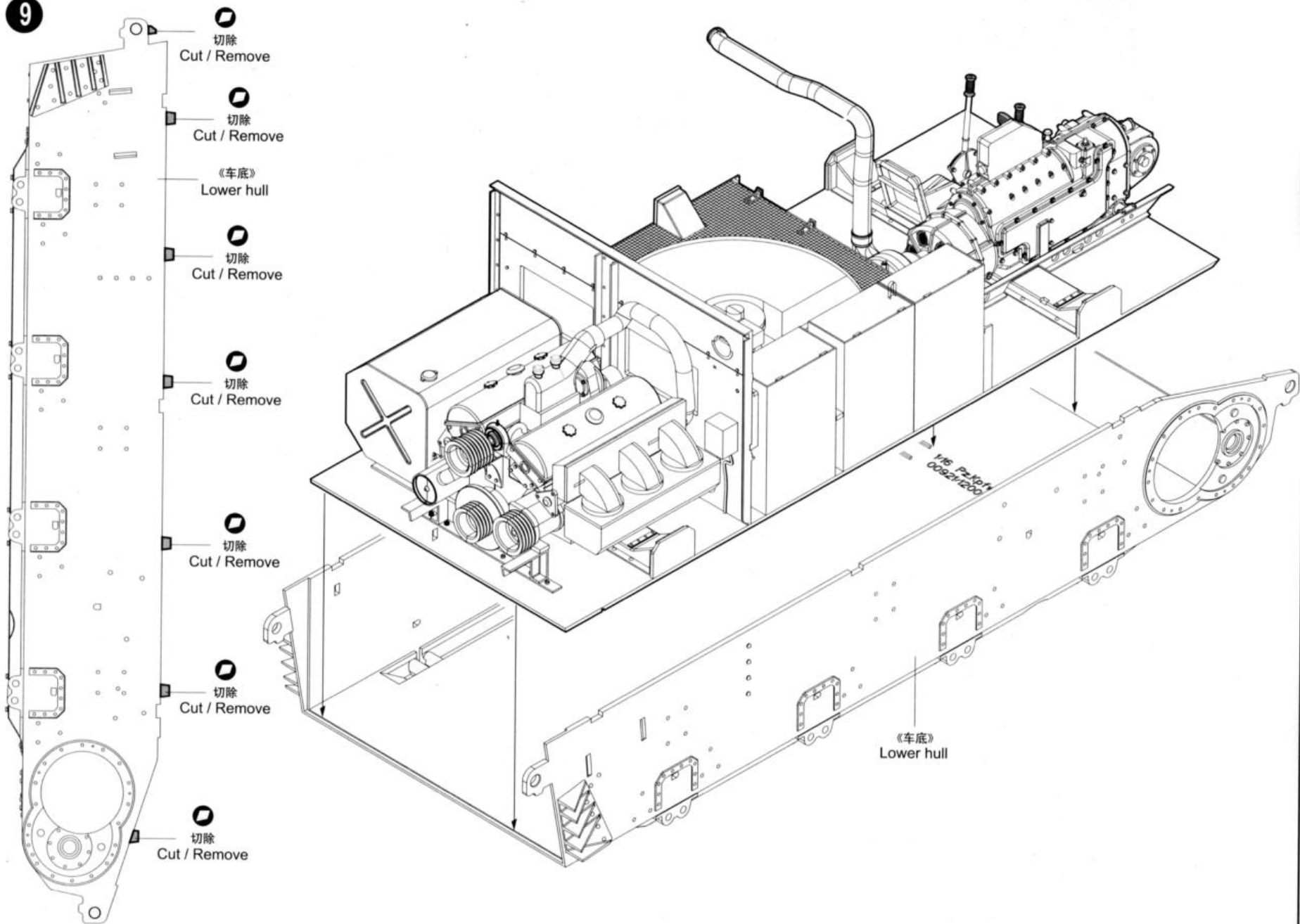

10

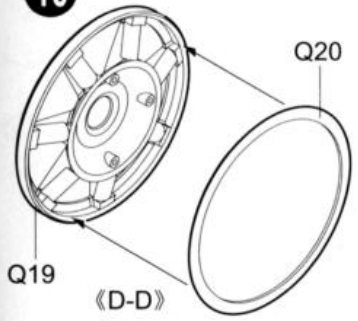

《D-D》
制作2组
Make two

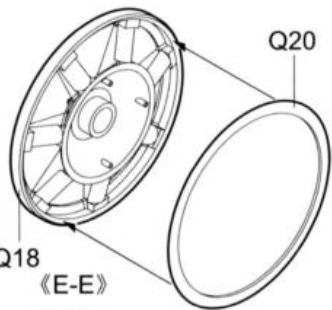

《E-E》
制作2组
Make two

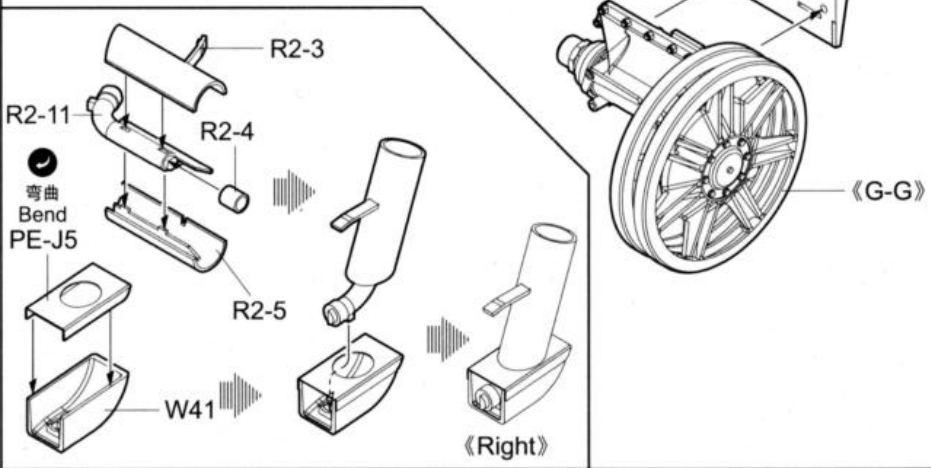
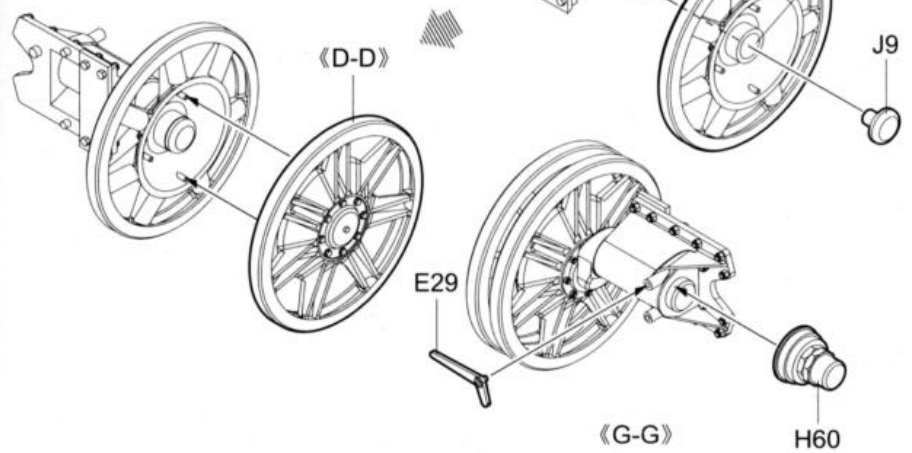
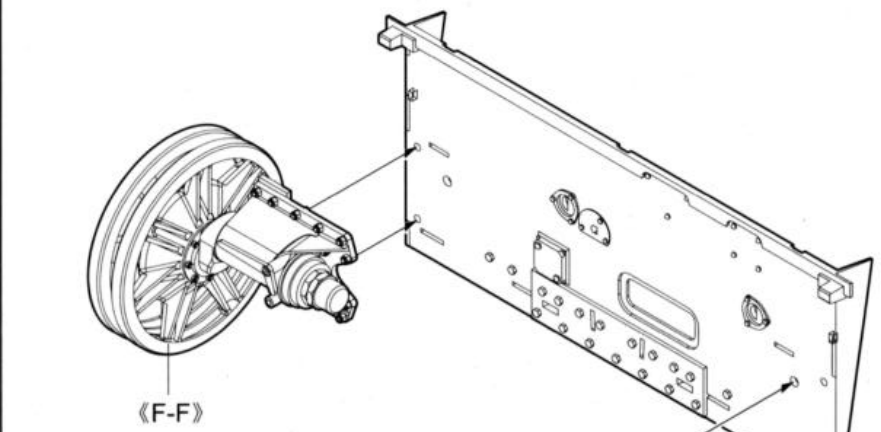
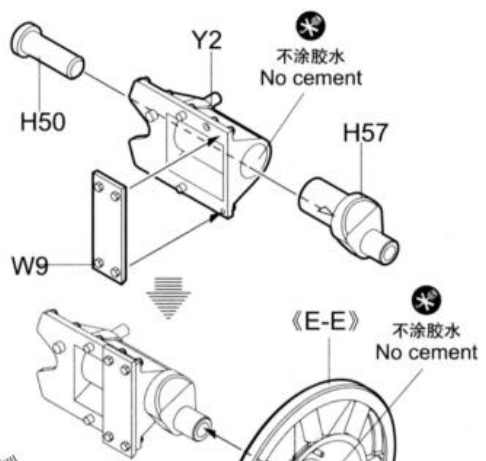
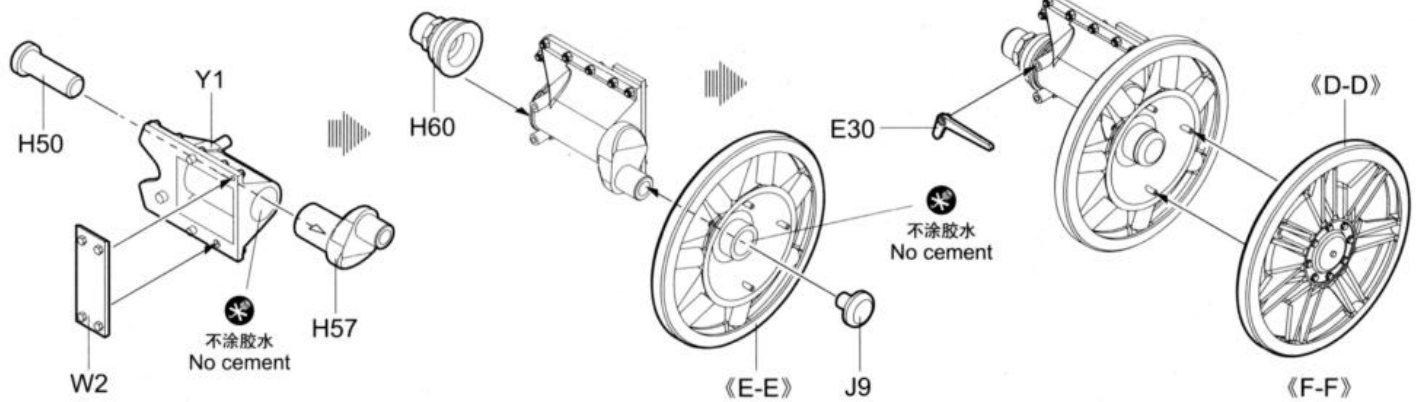

11

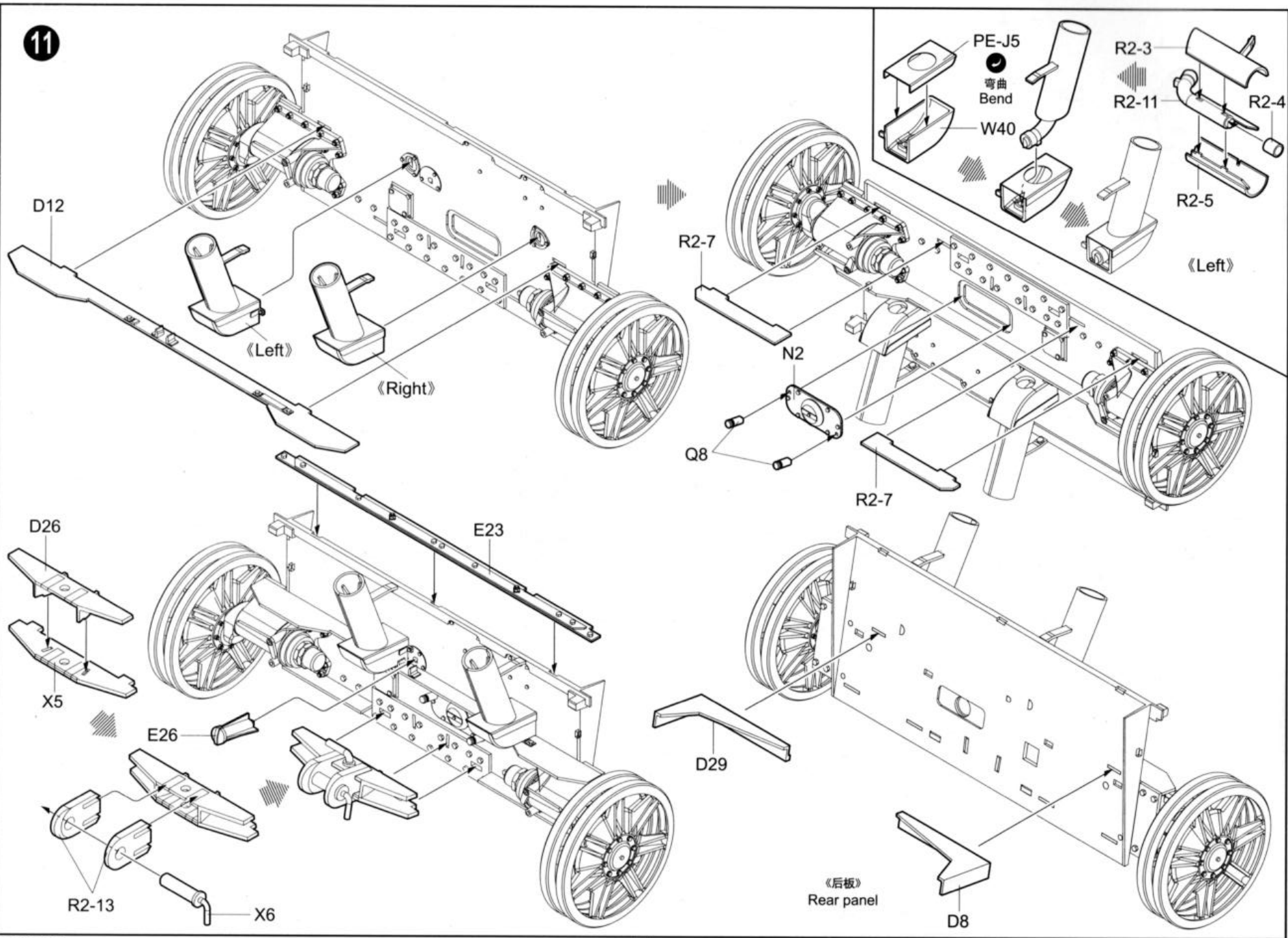

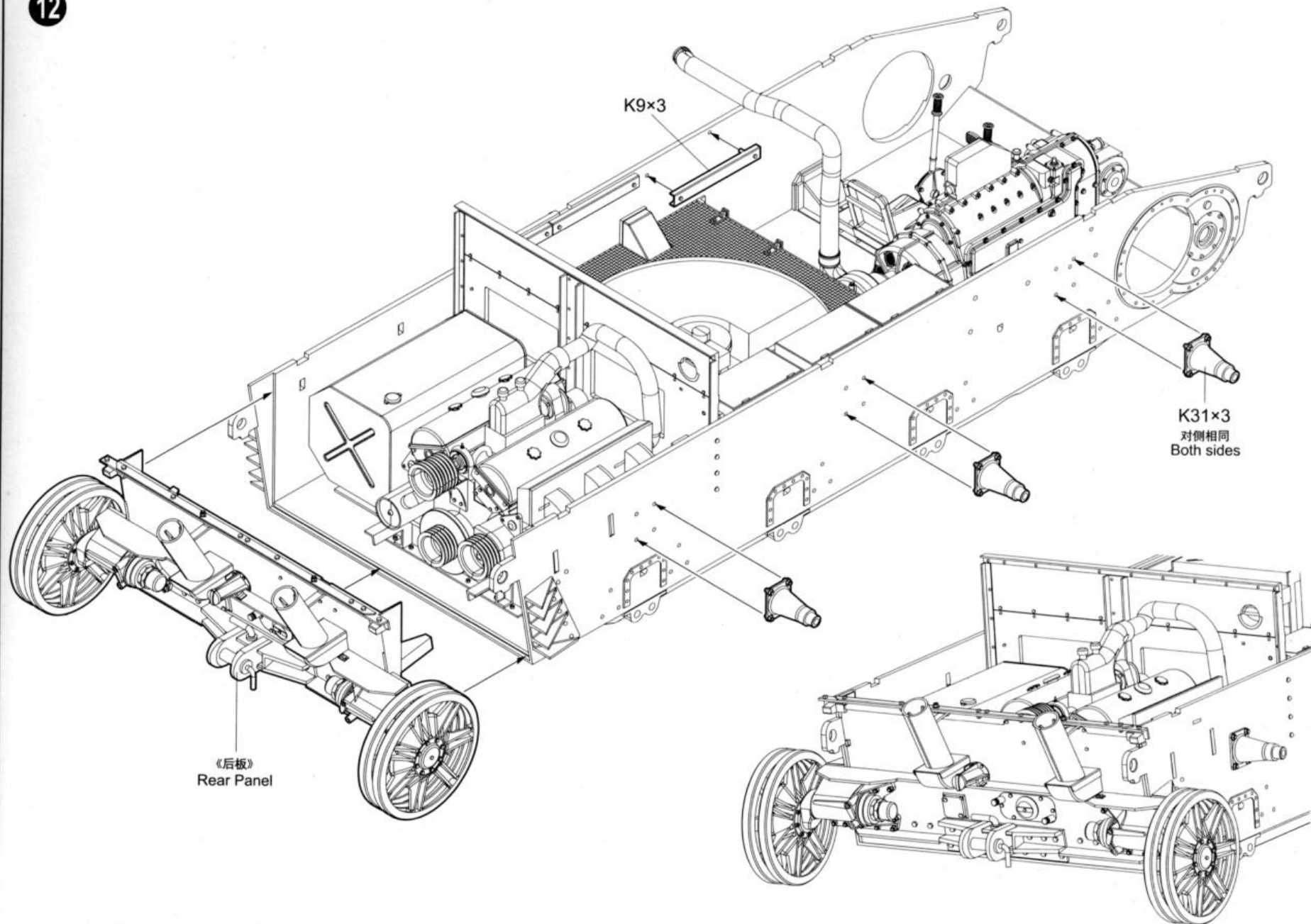

13

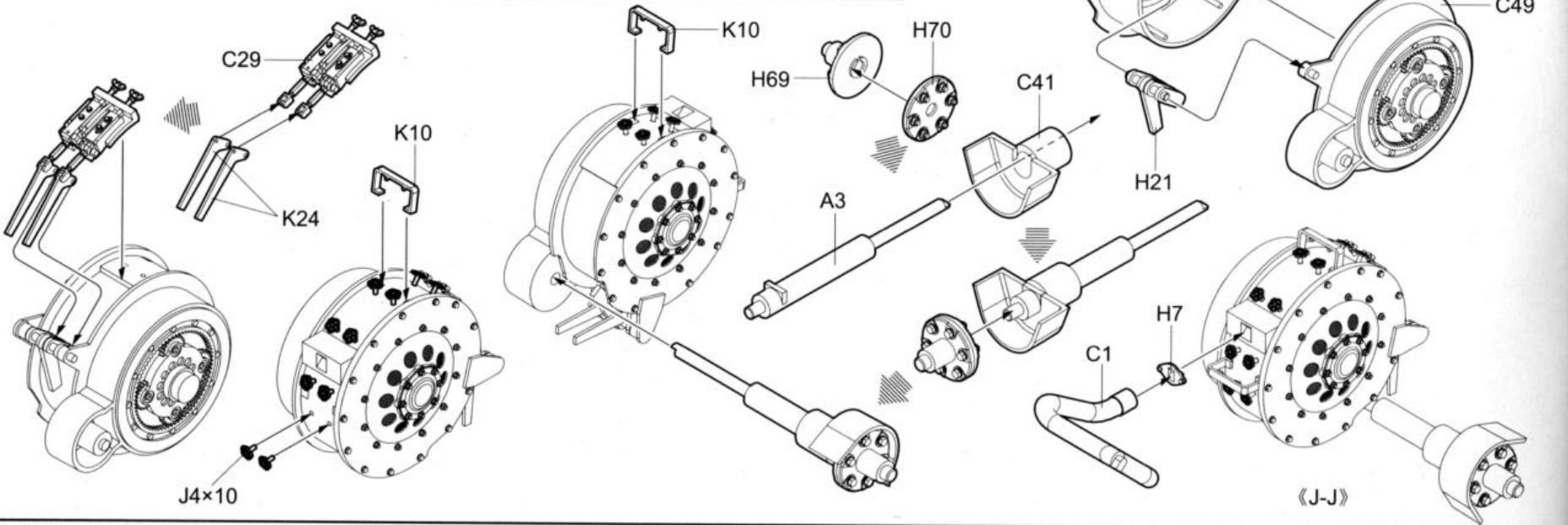
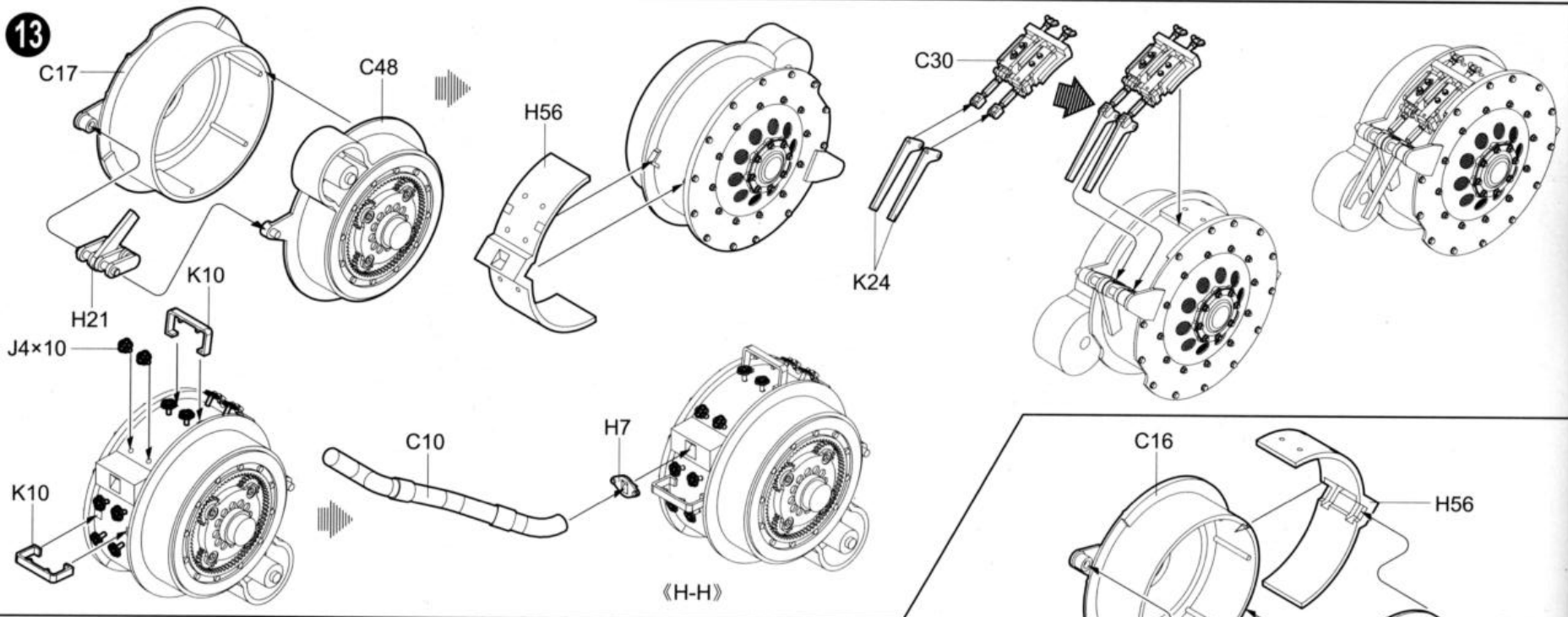

14

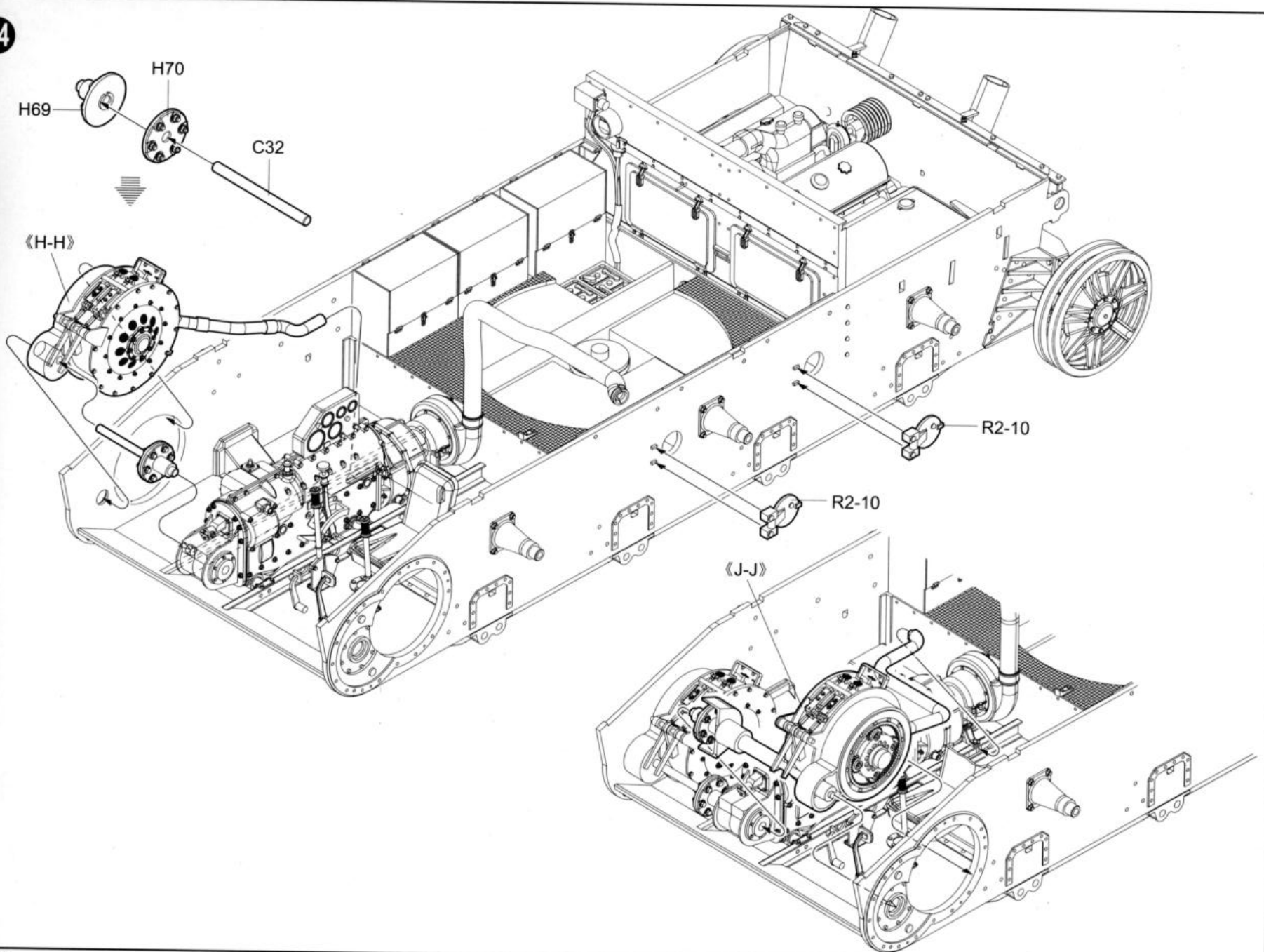

15

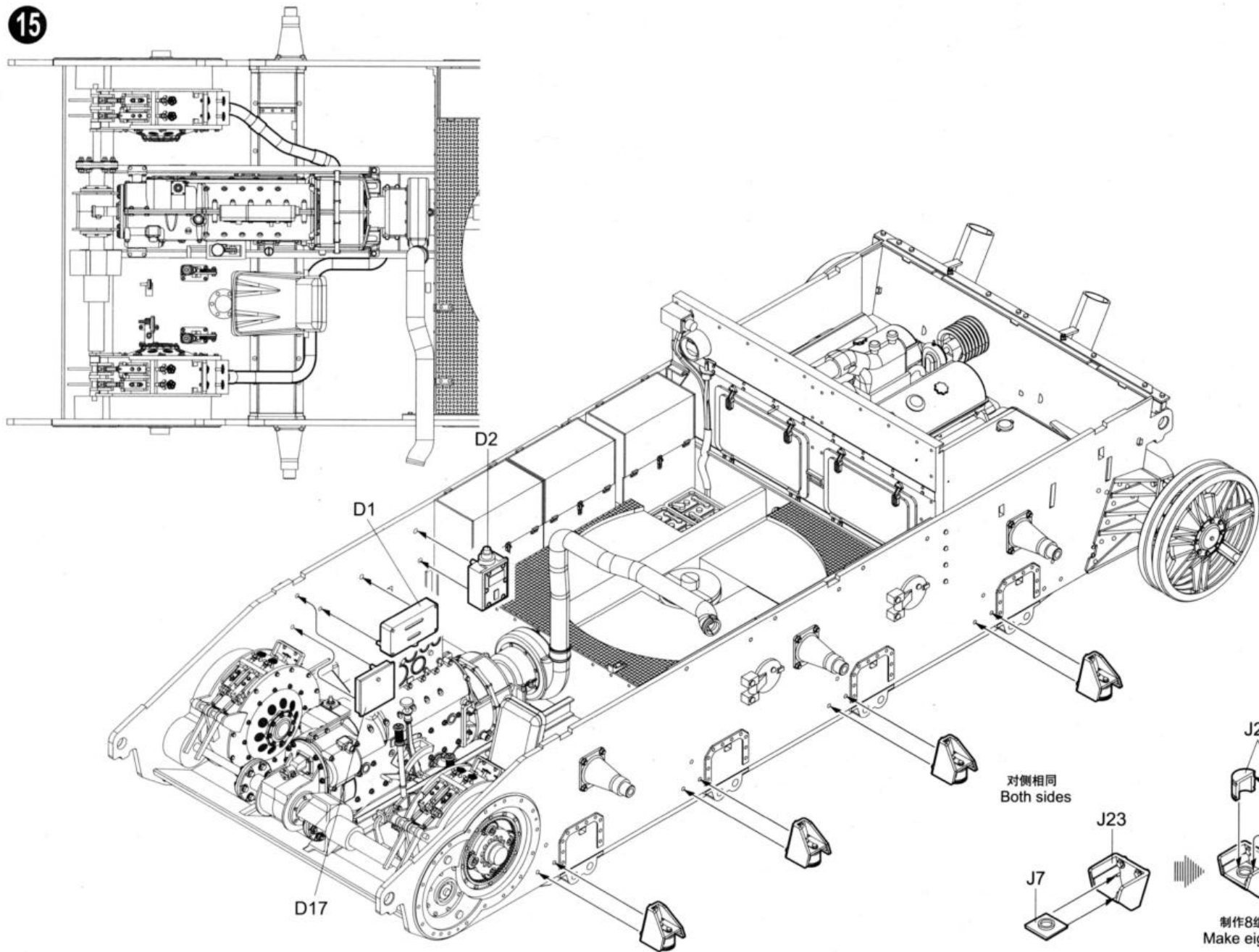

16

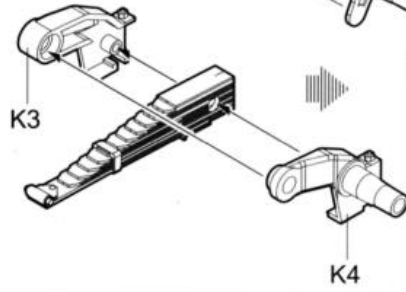
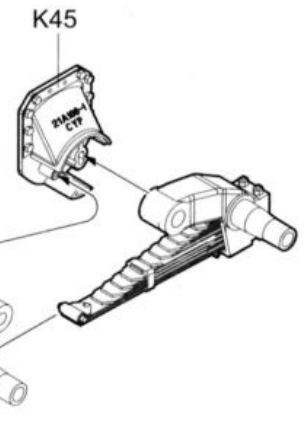
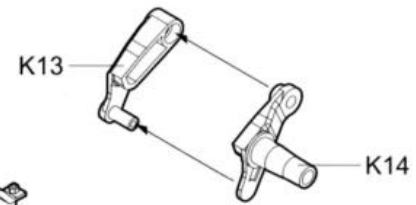
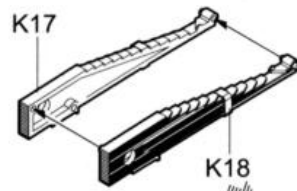
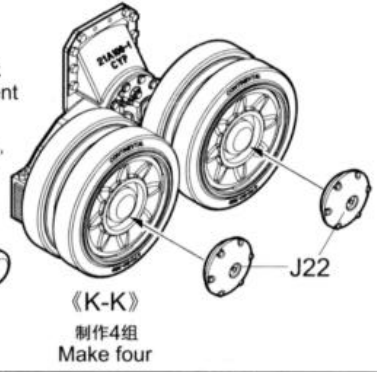
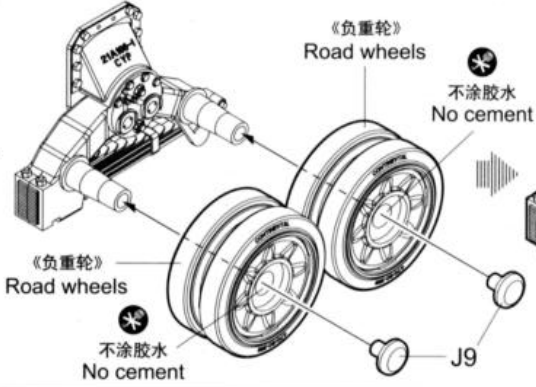
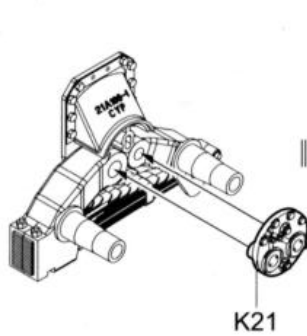
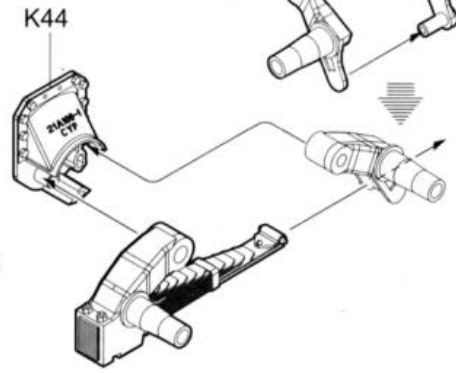
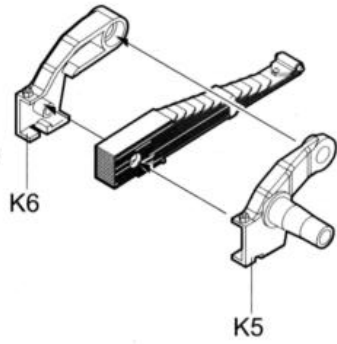
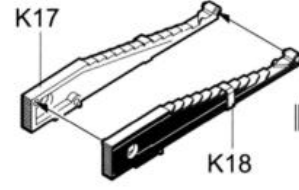
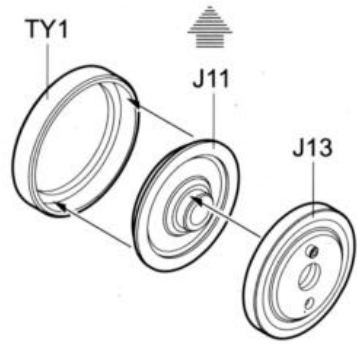
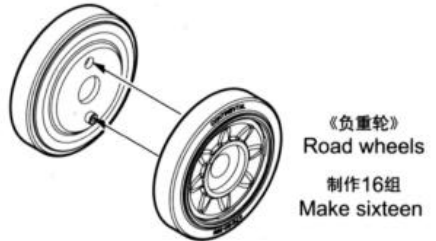
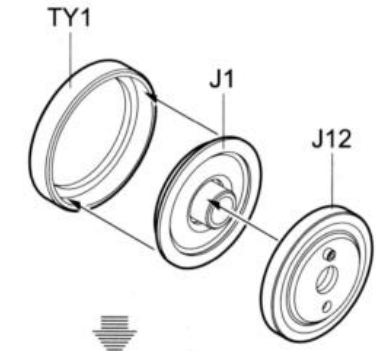

17

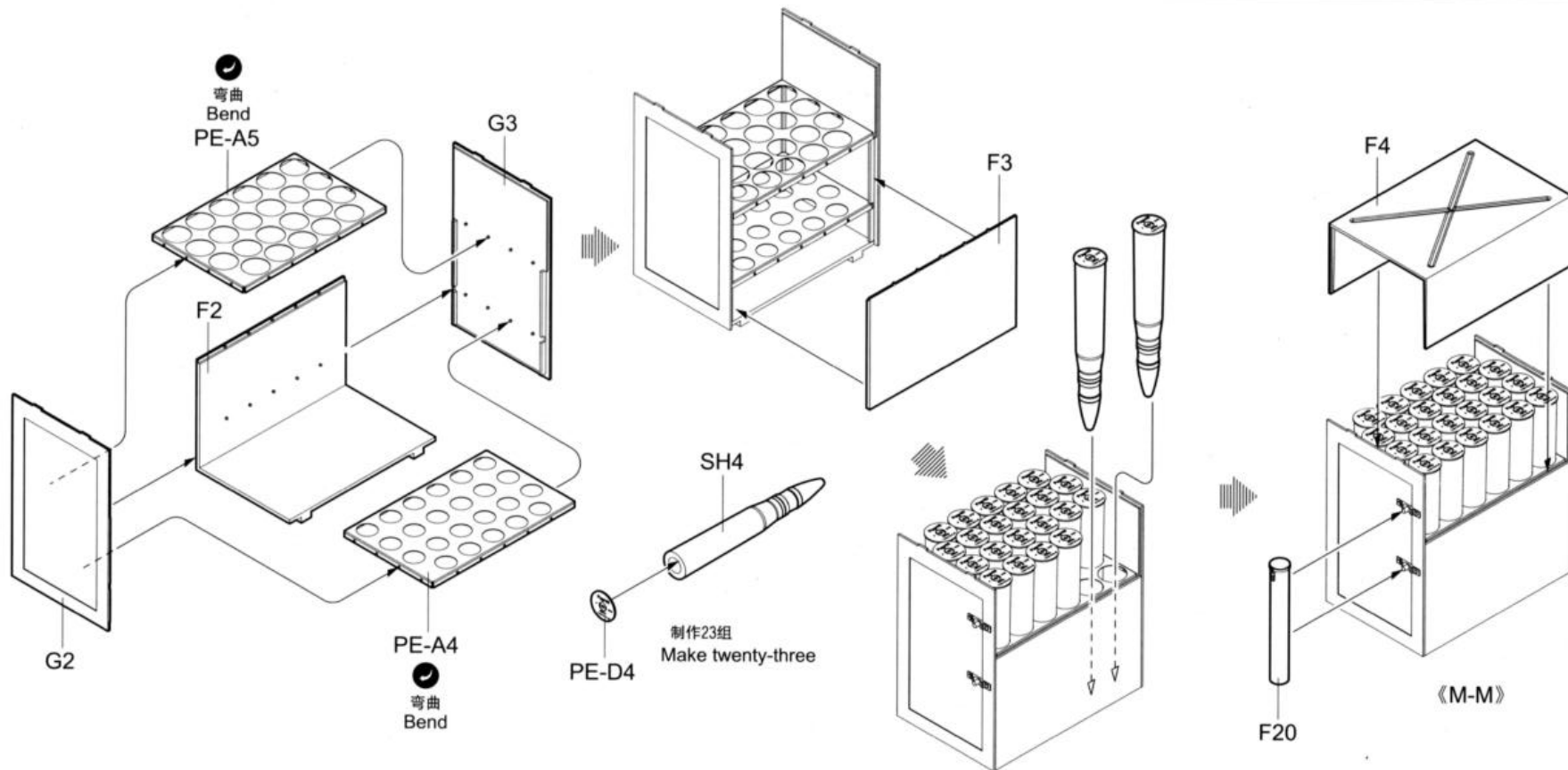
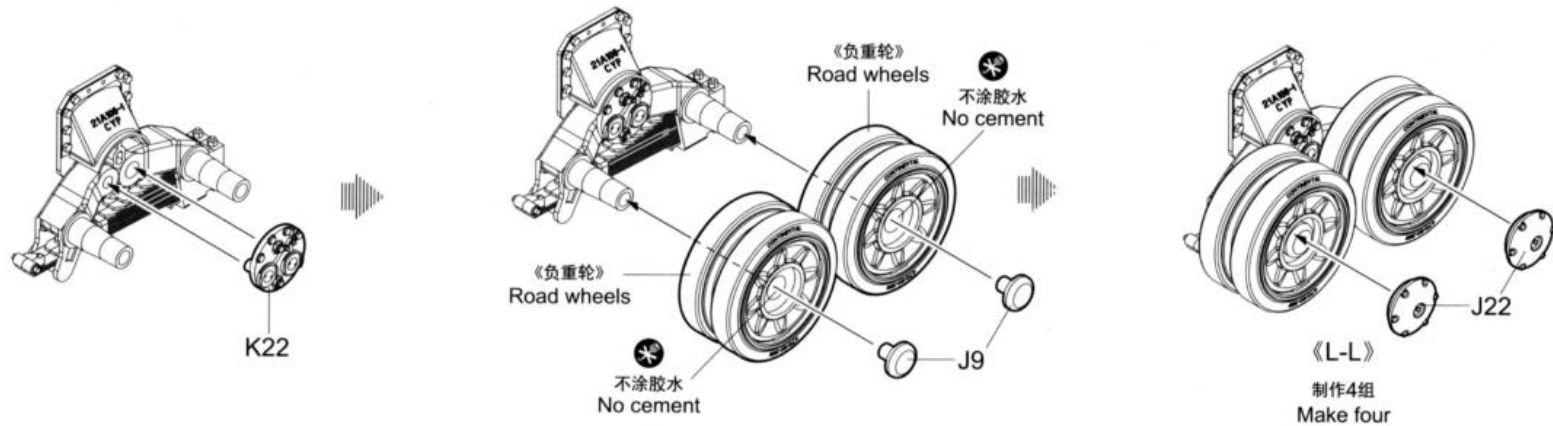

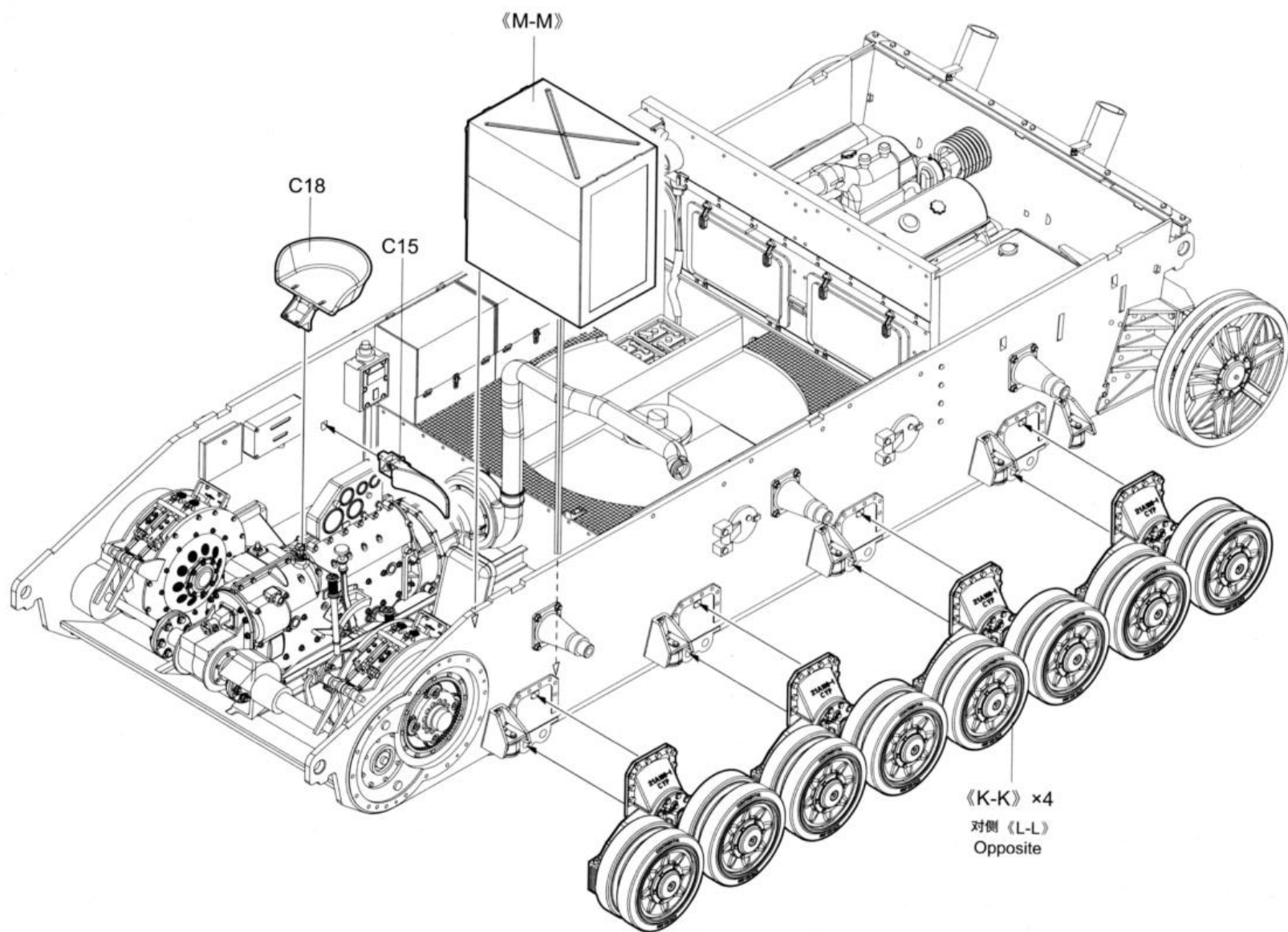

19

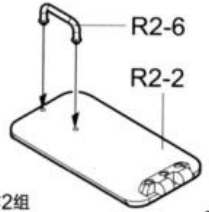

制作2组
Make two

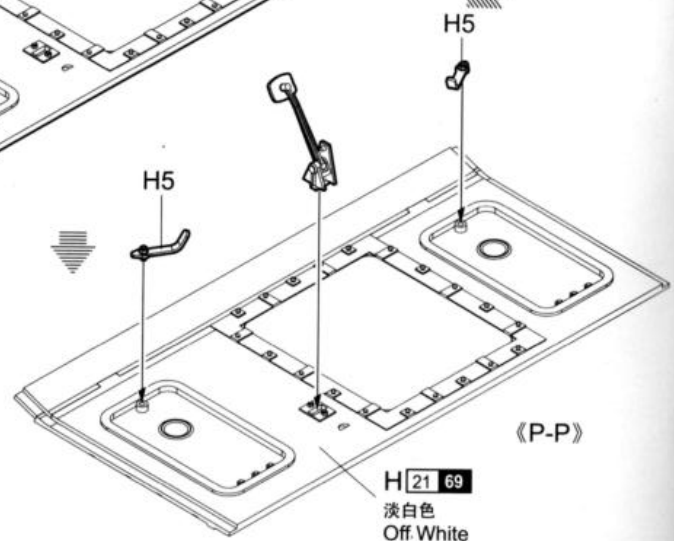
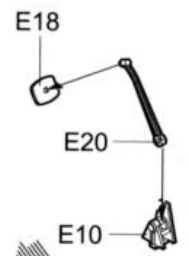
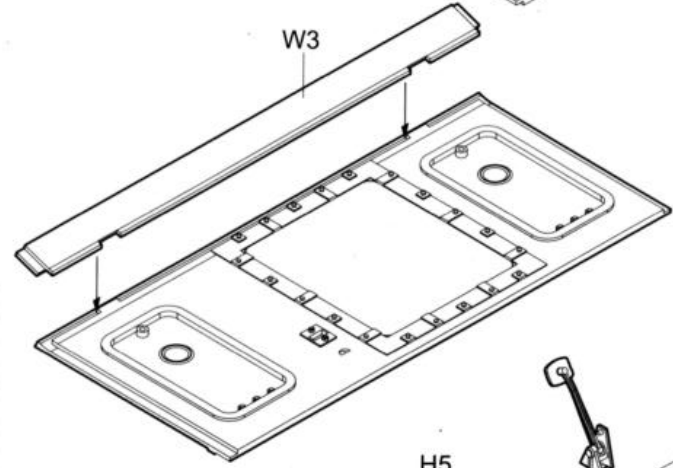
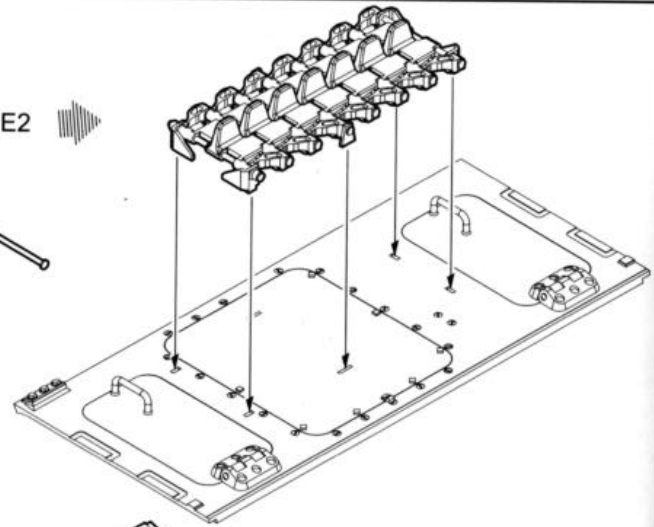
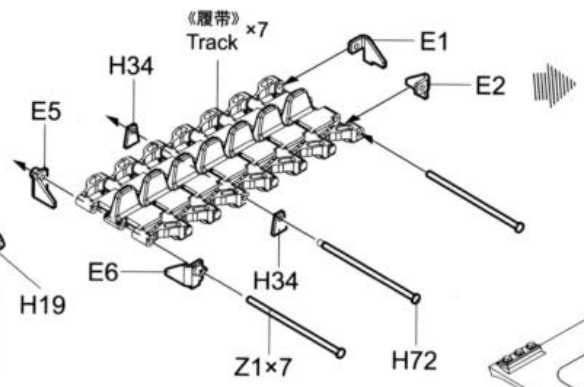
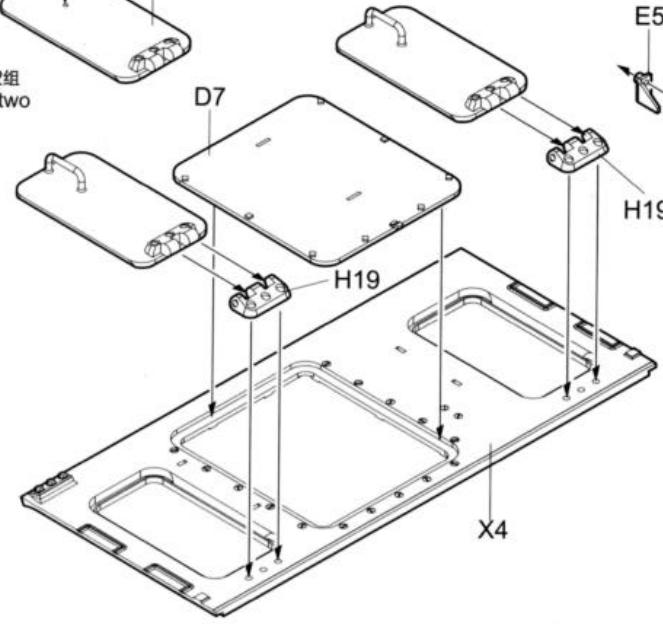

《P-P》

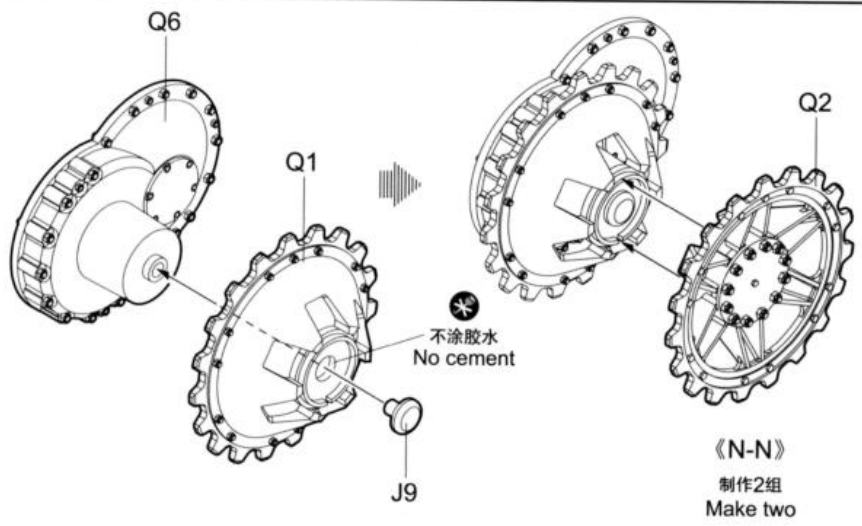

《N-N》
制作2组
Make two

20



钻孔
Make hole

M1

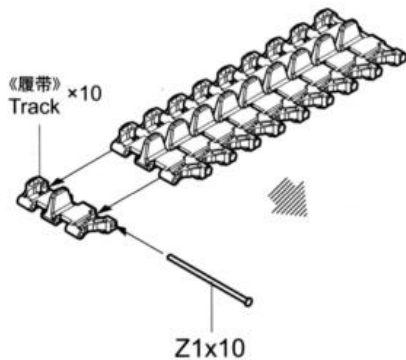
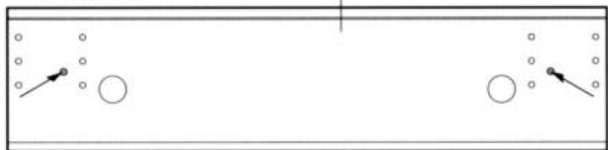

《履带》
Track x10

Z1x10

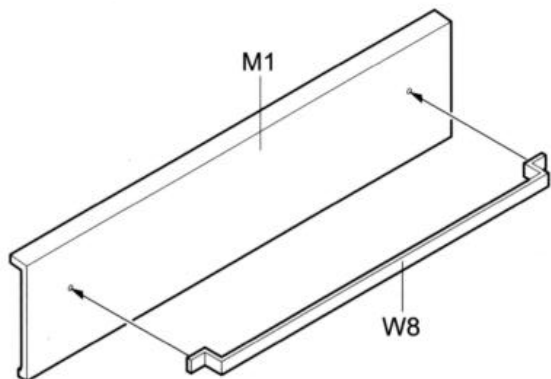
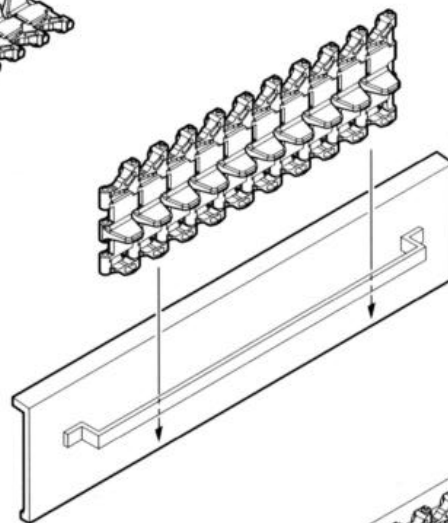

M1

W8

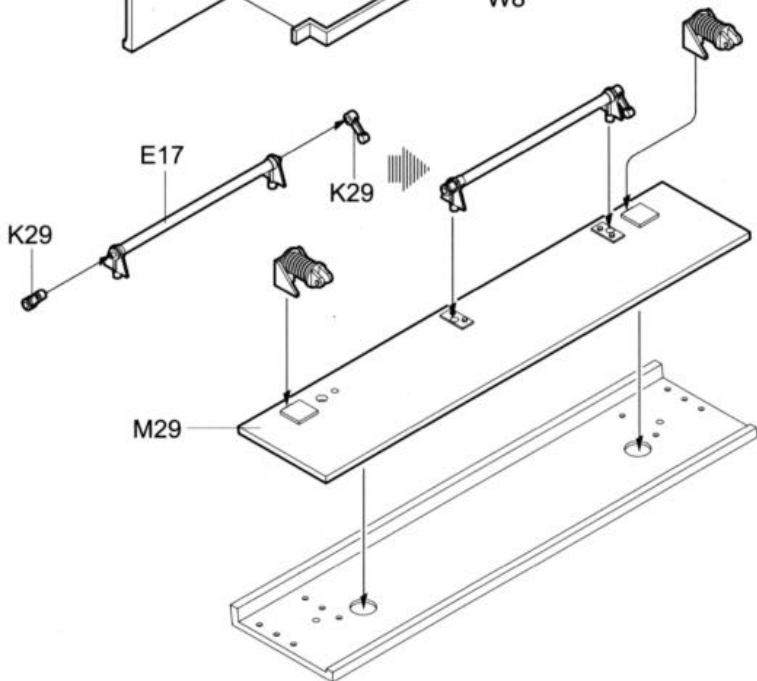

E17

K29

K29

M29

H16

H62

制作2组
Make two

E25

K29

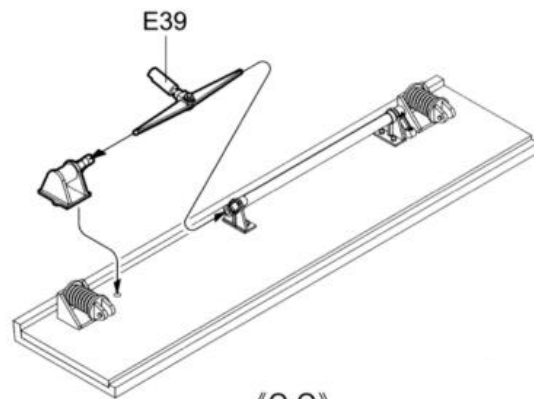

E39

《Q-Q》

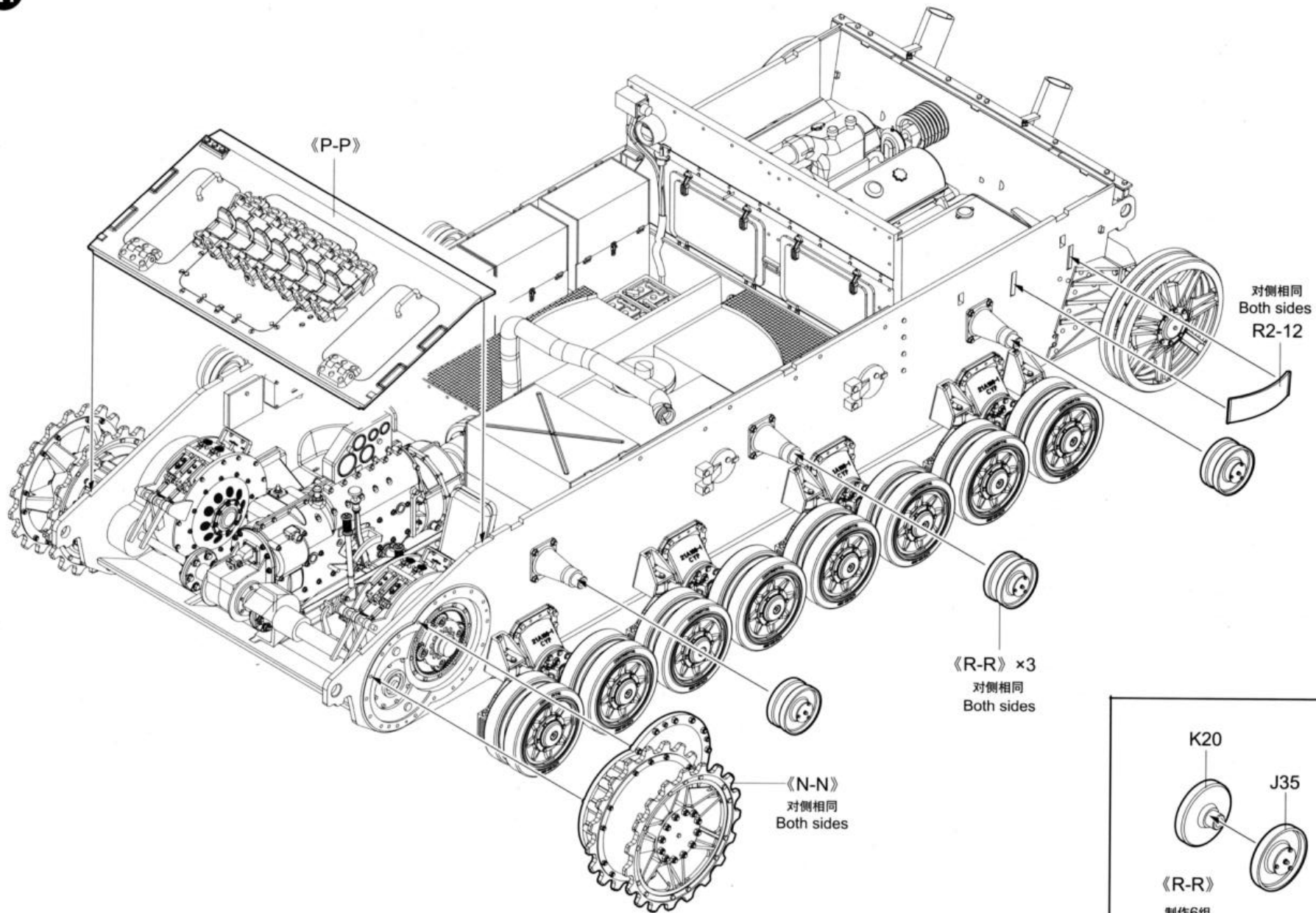

《左侧履带》
Left tracks

《右侧履带》
Right tracks

单侧履带需要99节
Complete track for one side requires 99 links.

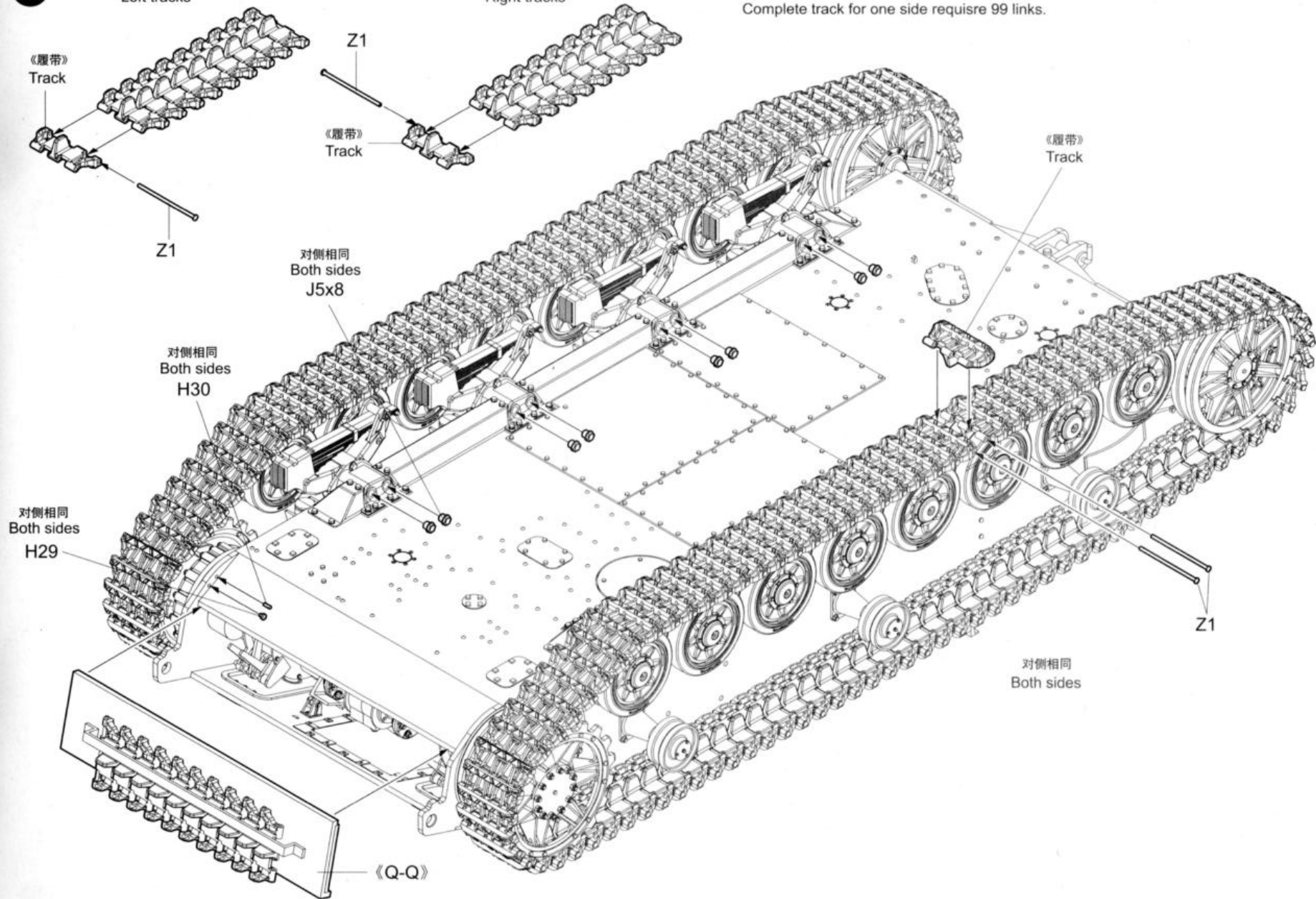

23

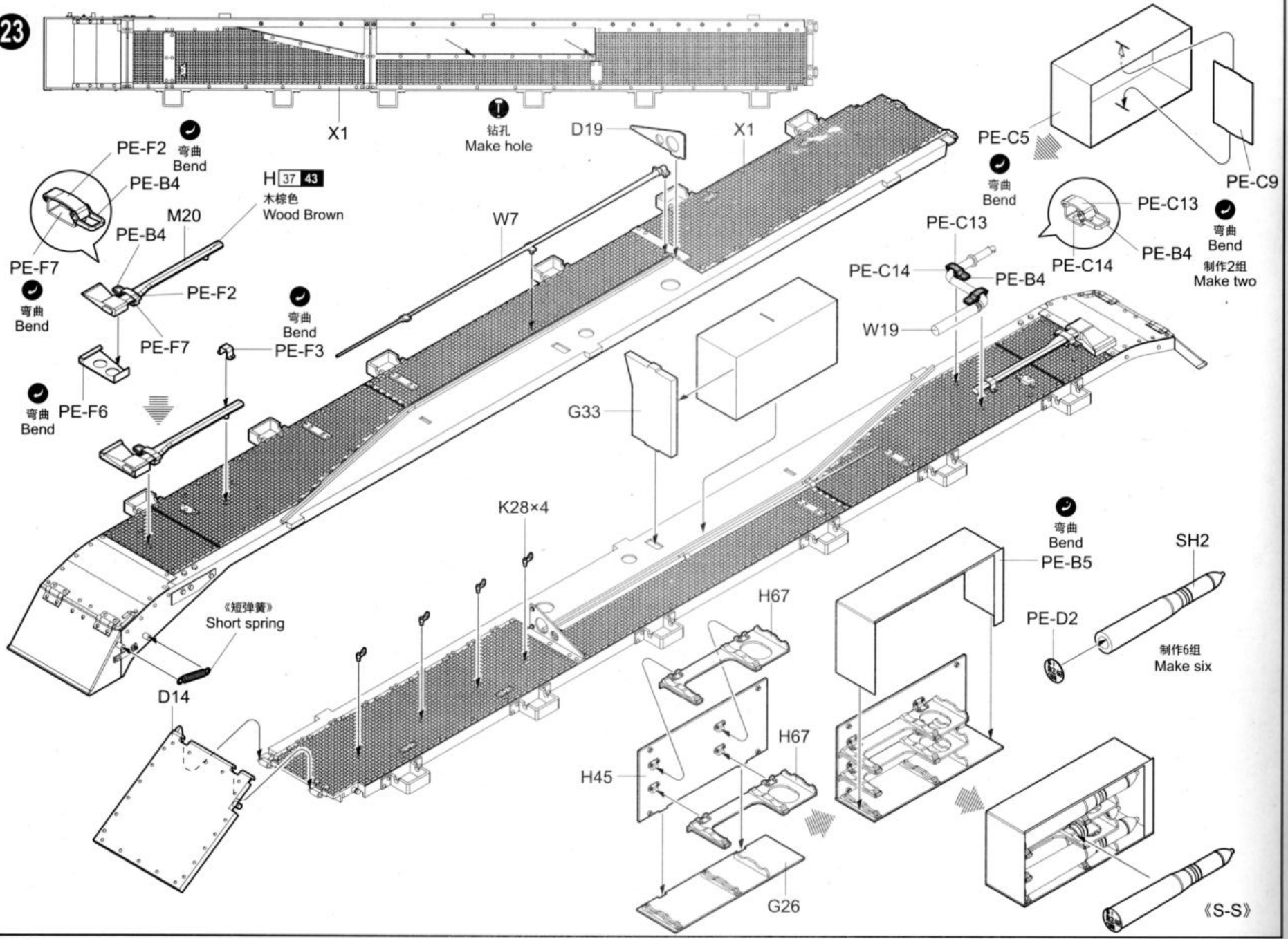

24

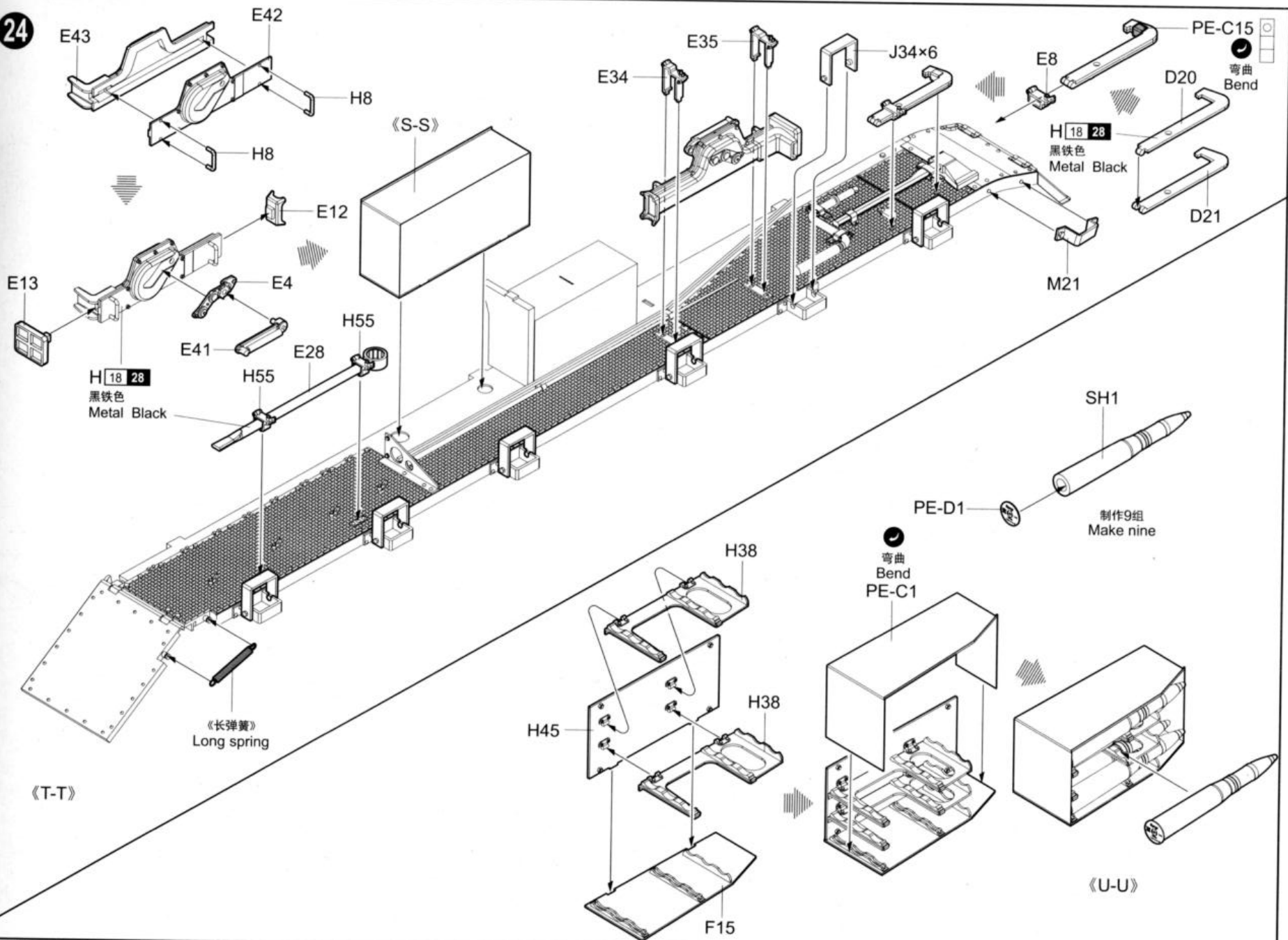

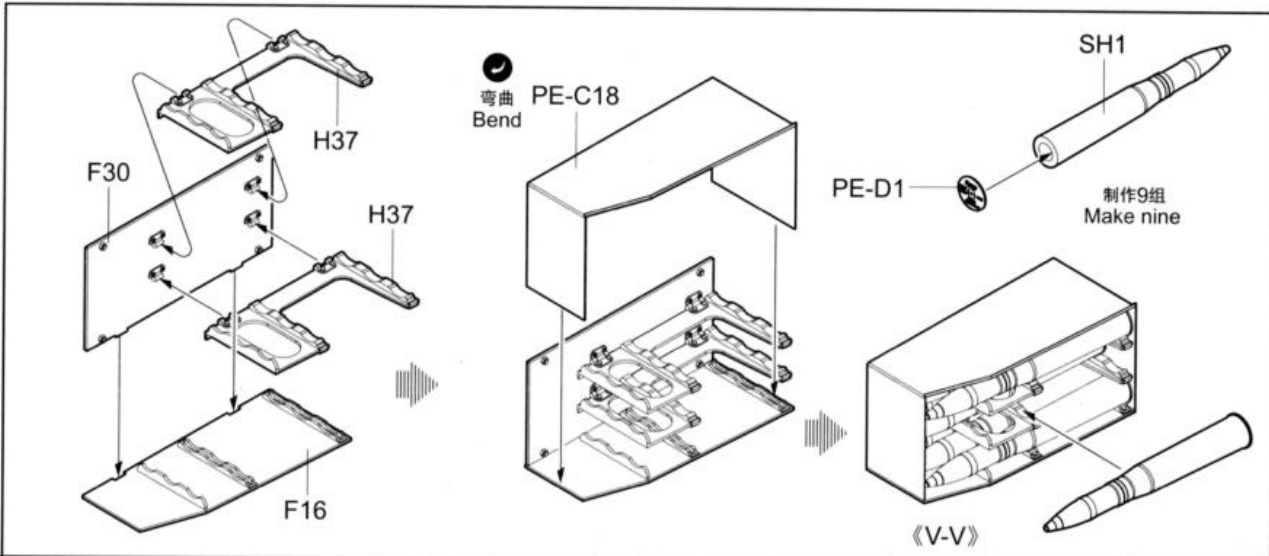
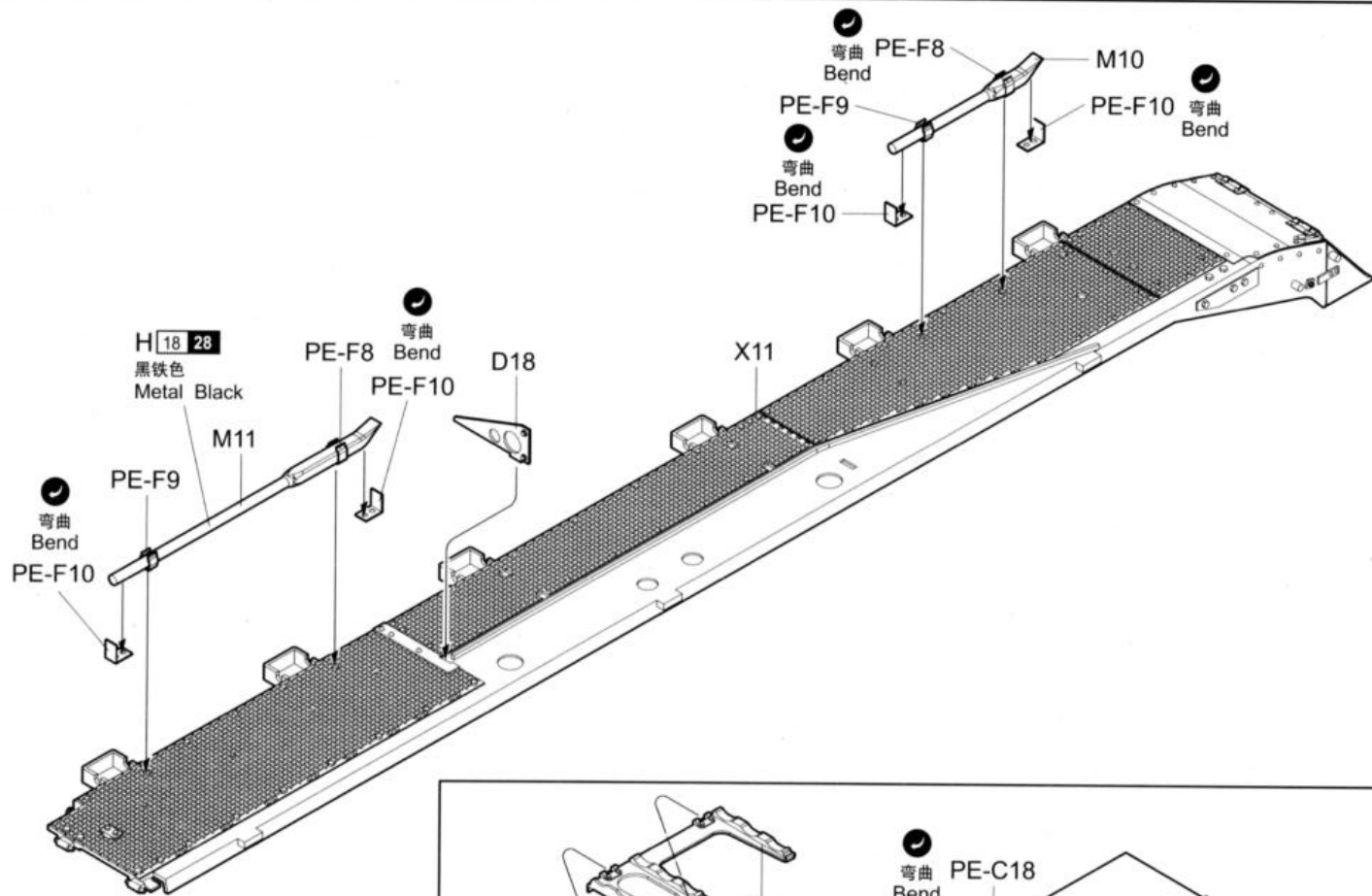

26

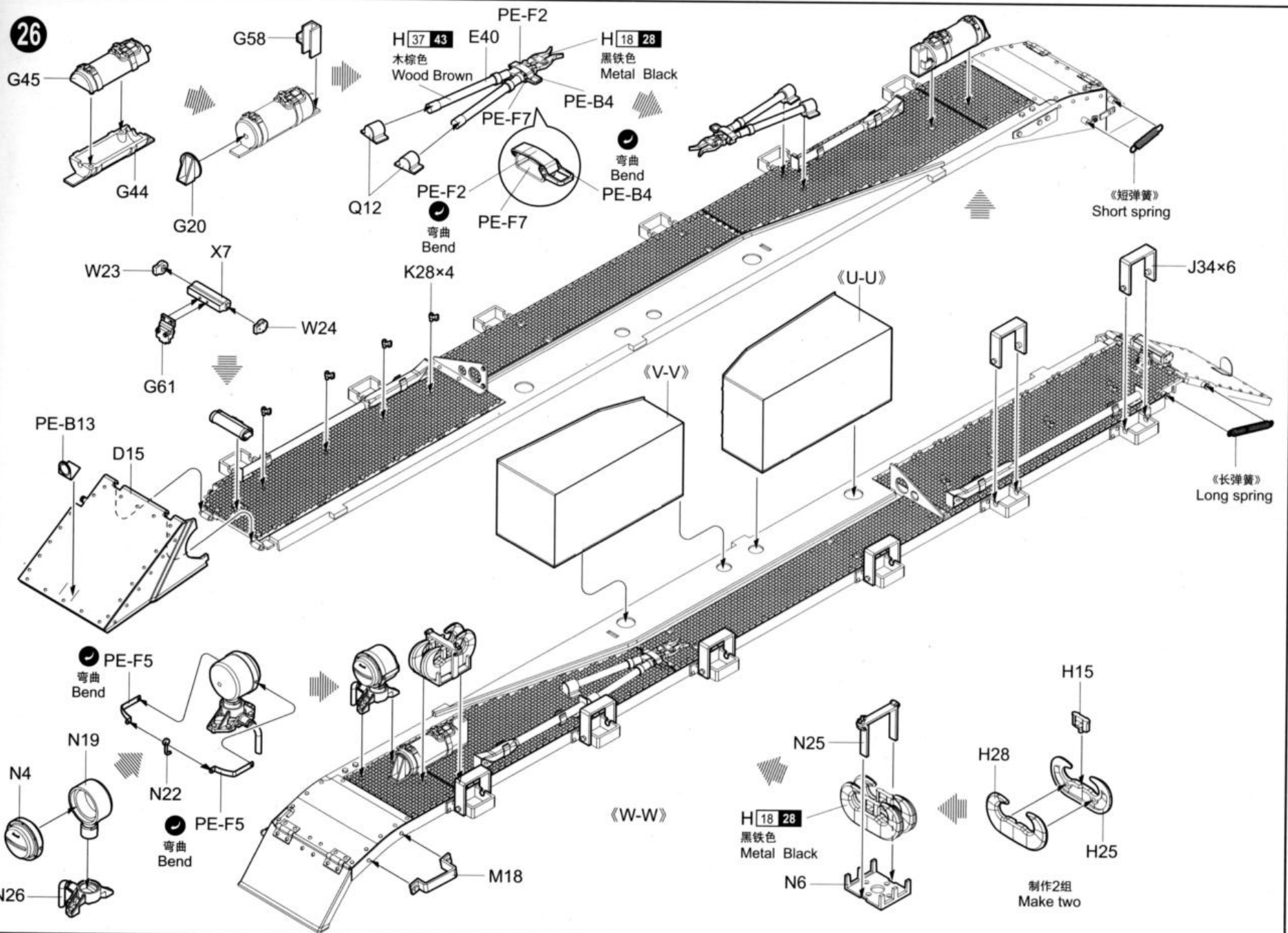

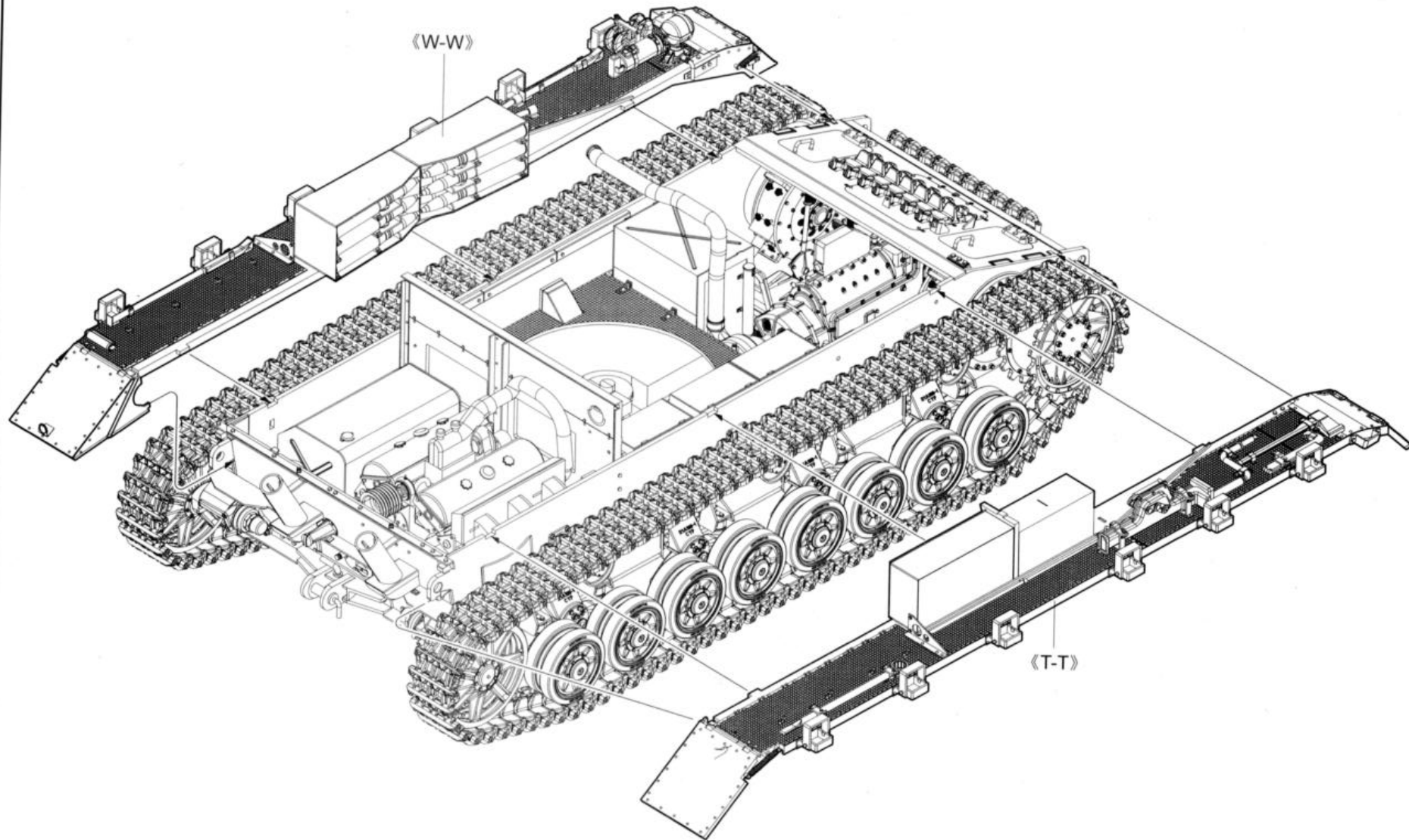

28

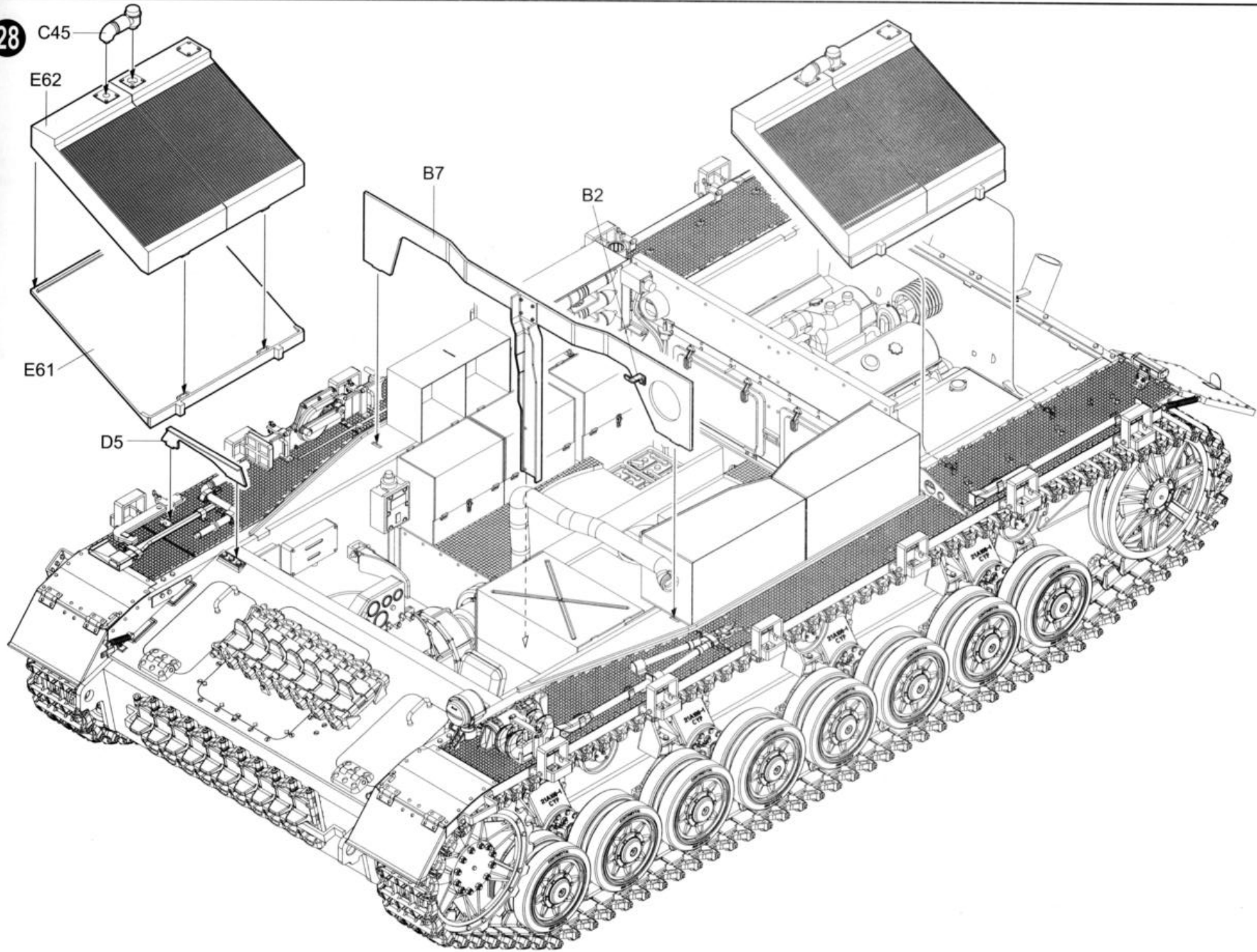

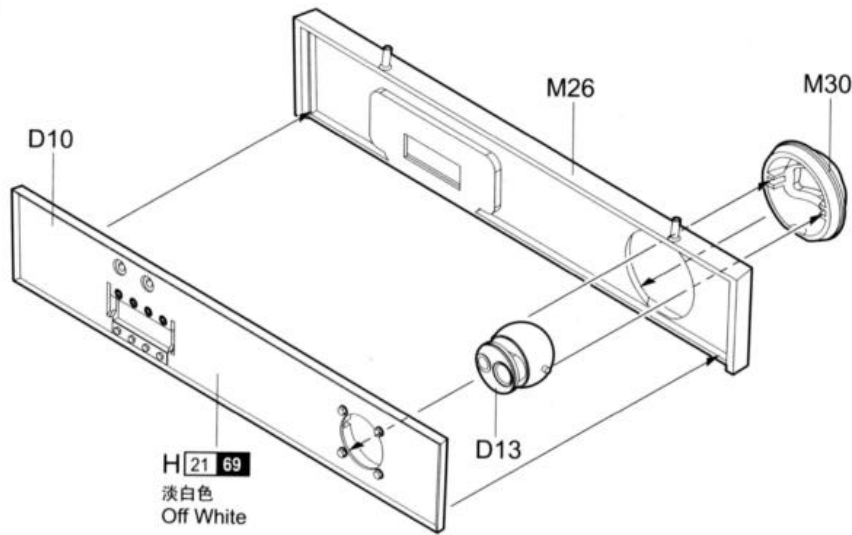

H 21 69
淡白色
Off White

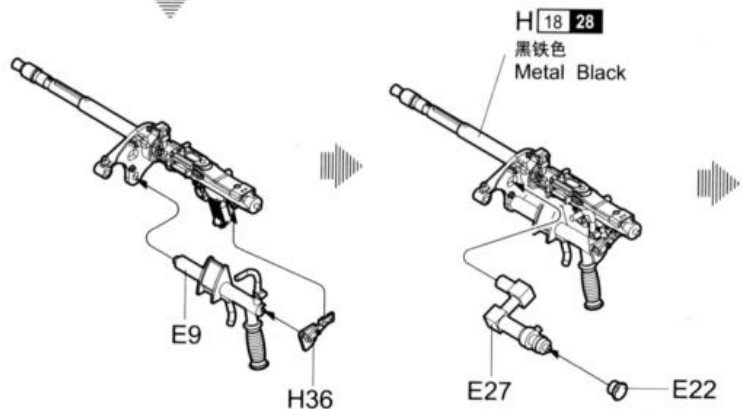
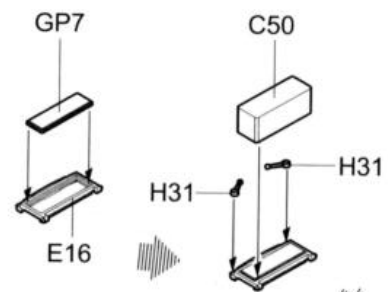
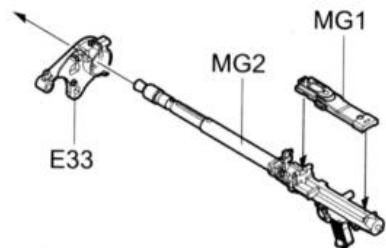
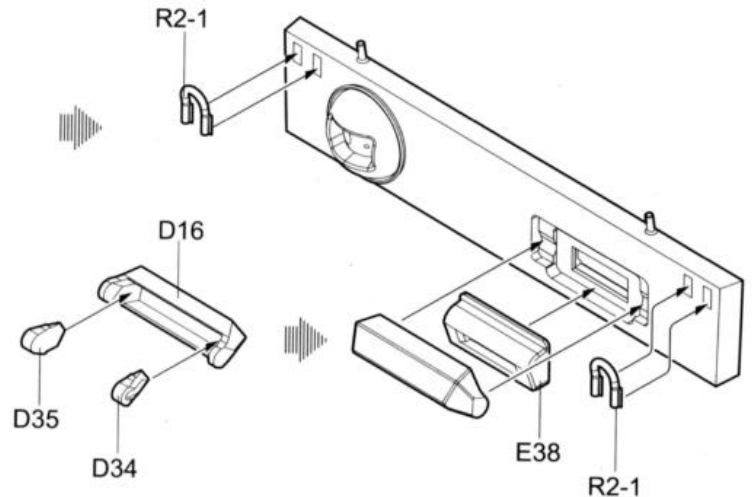

H 18 28
黑铁色
Metal Black

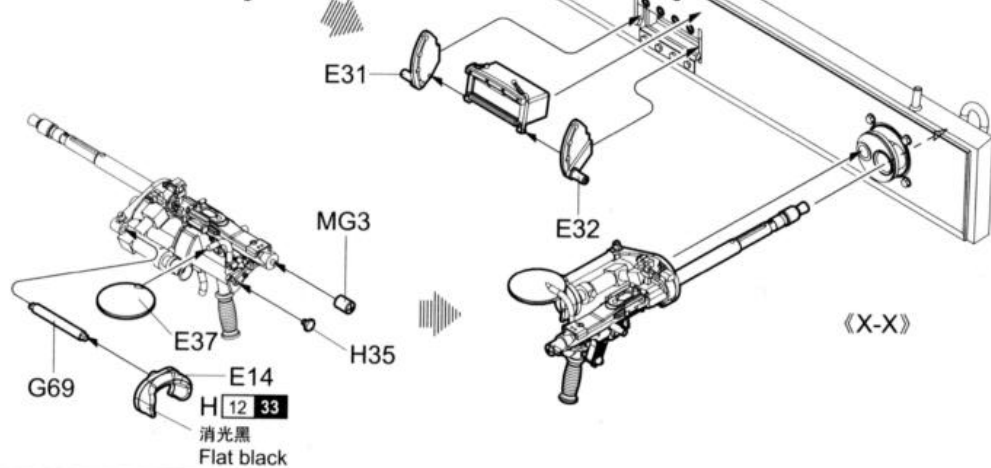

H 12 33
消光黑
Flat black

《X-X》

30

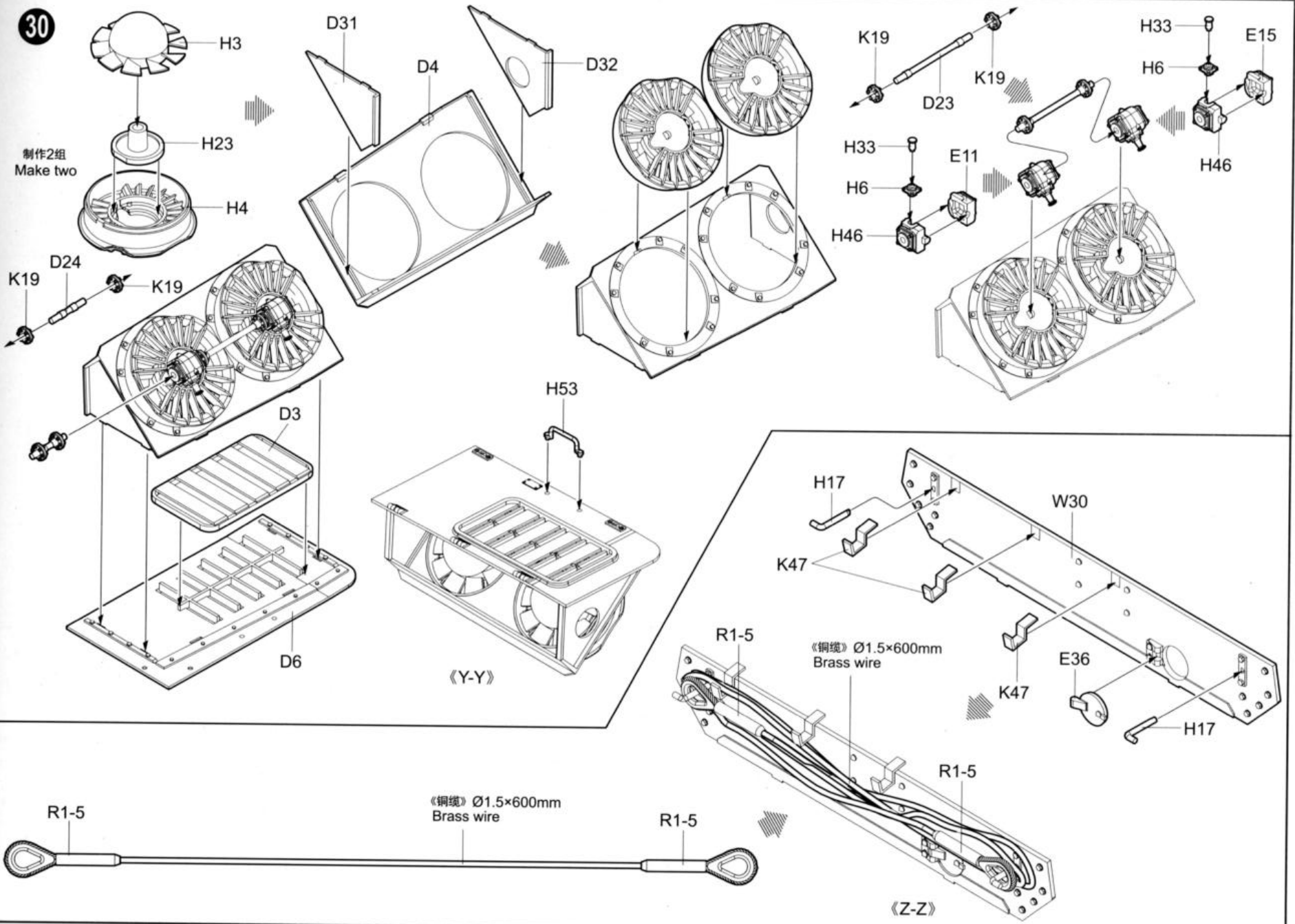

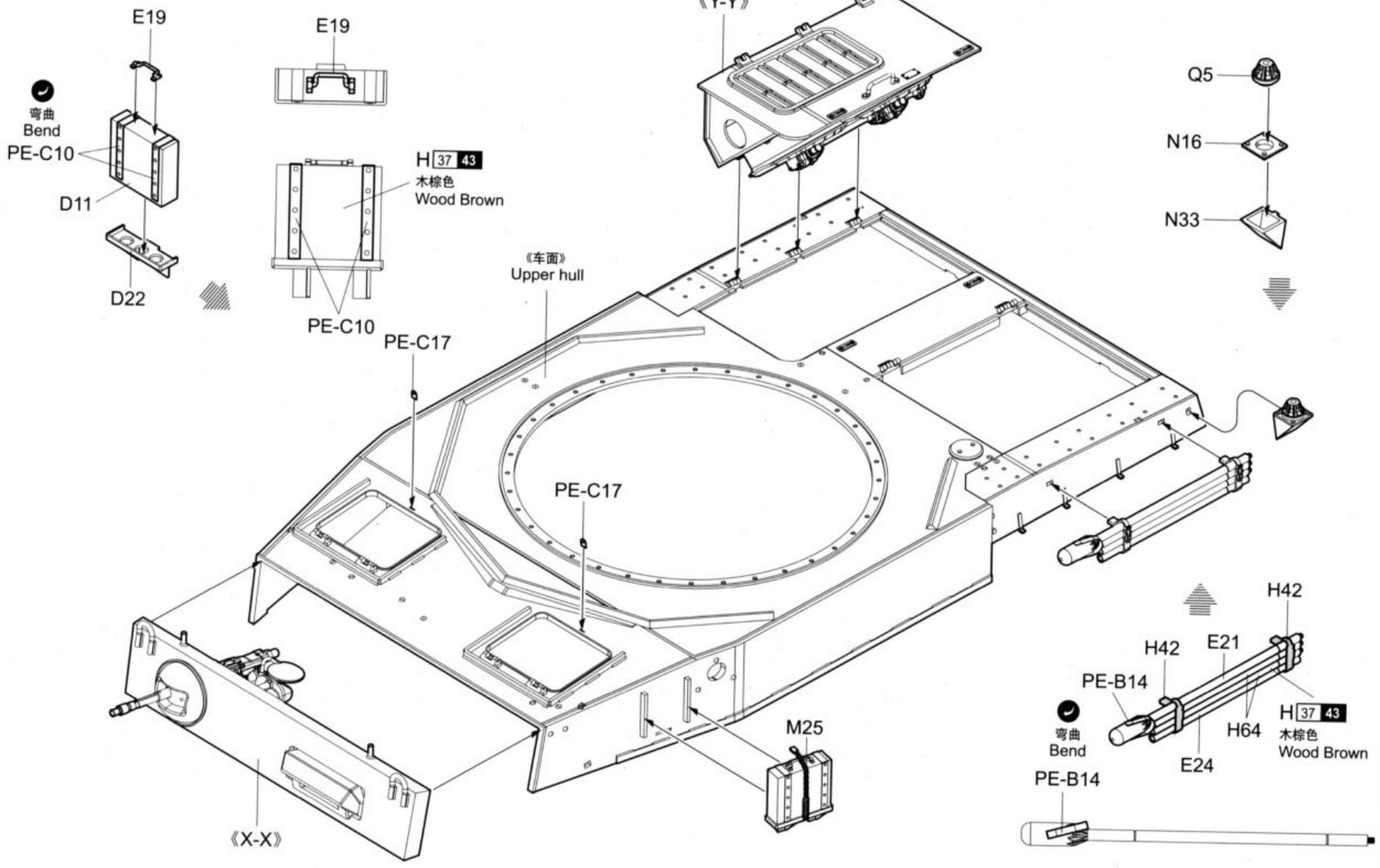

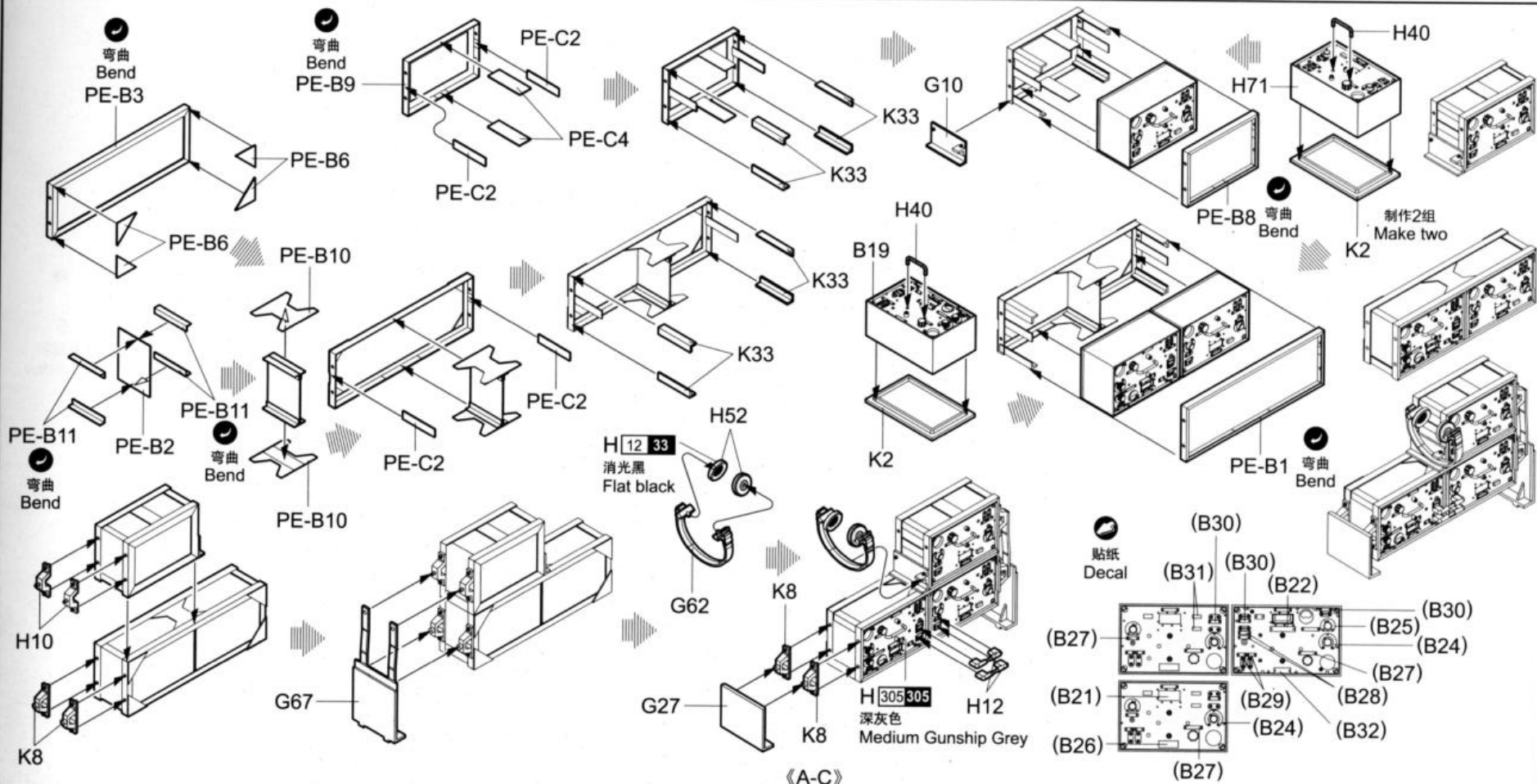
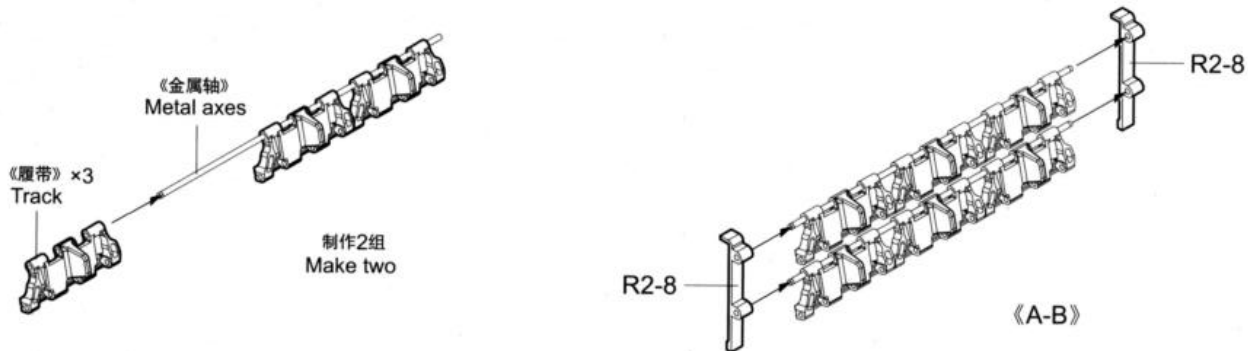

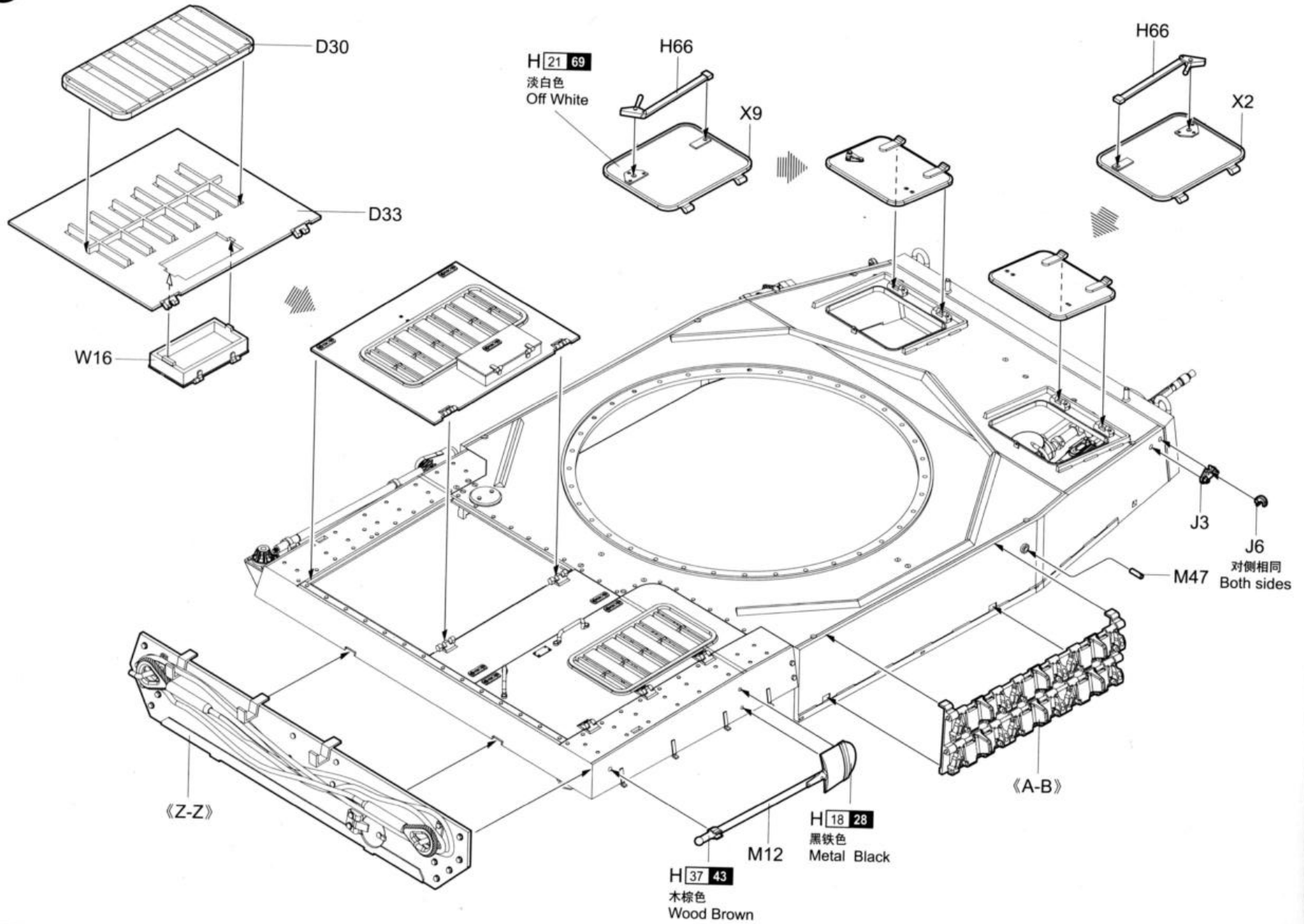

34

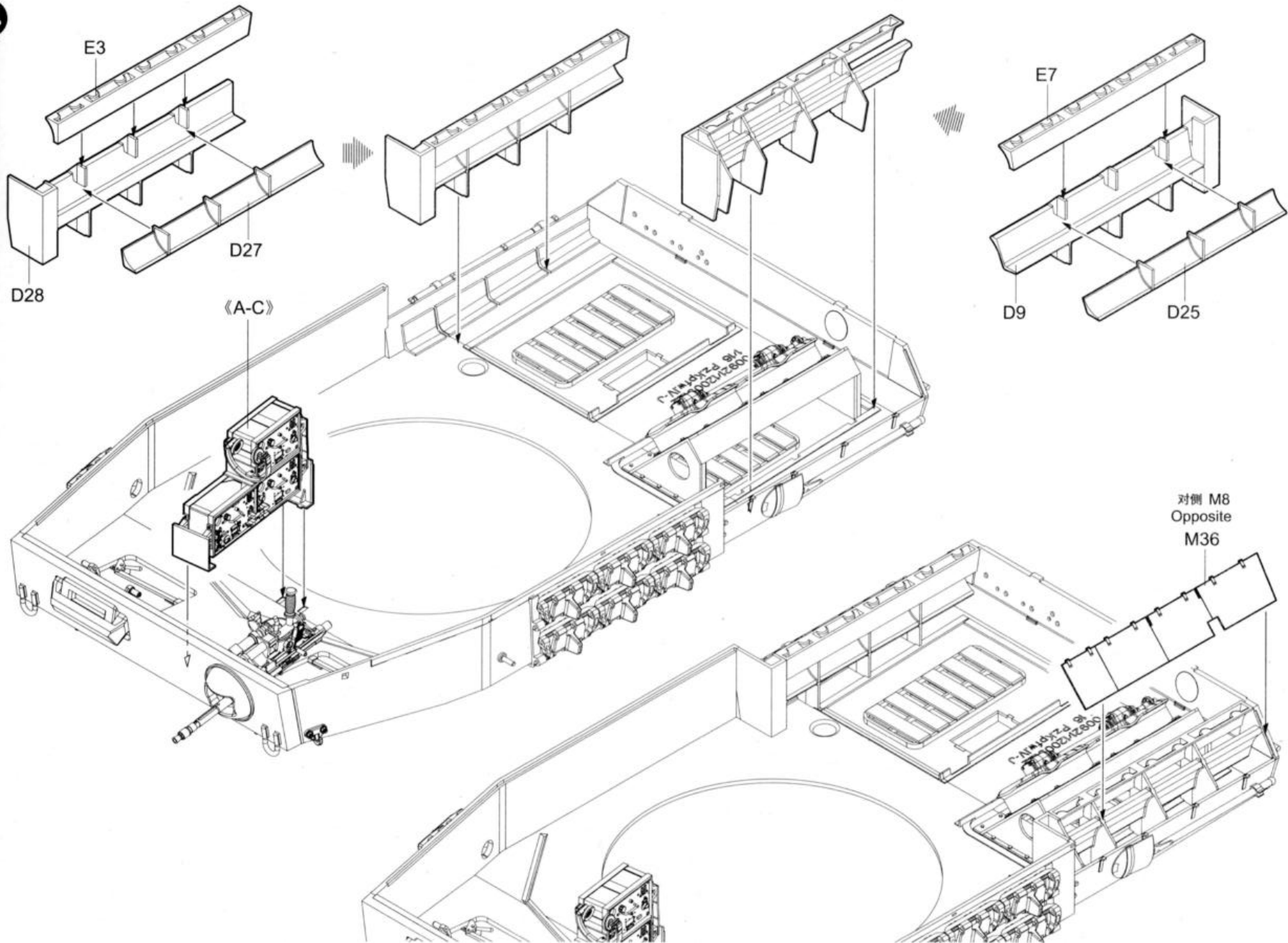

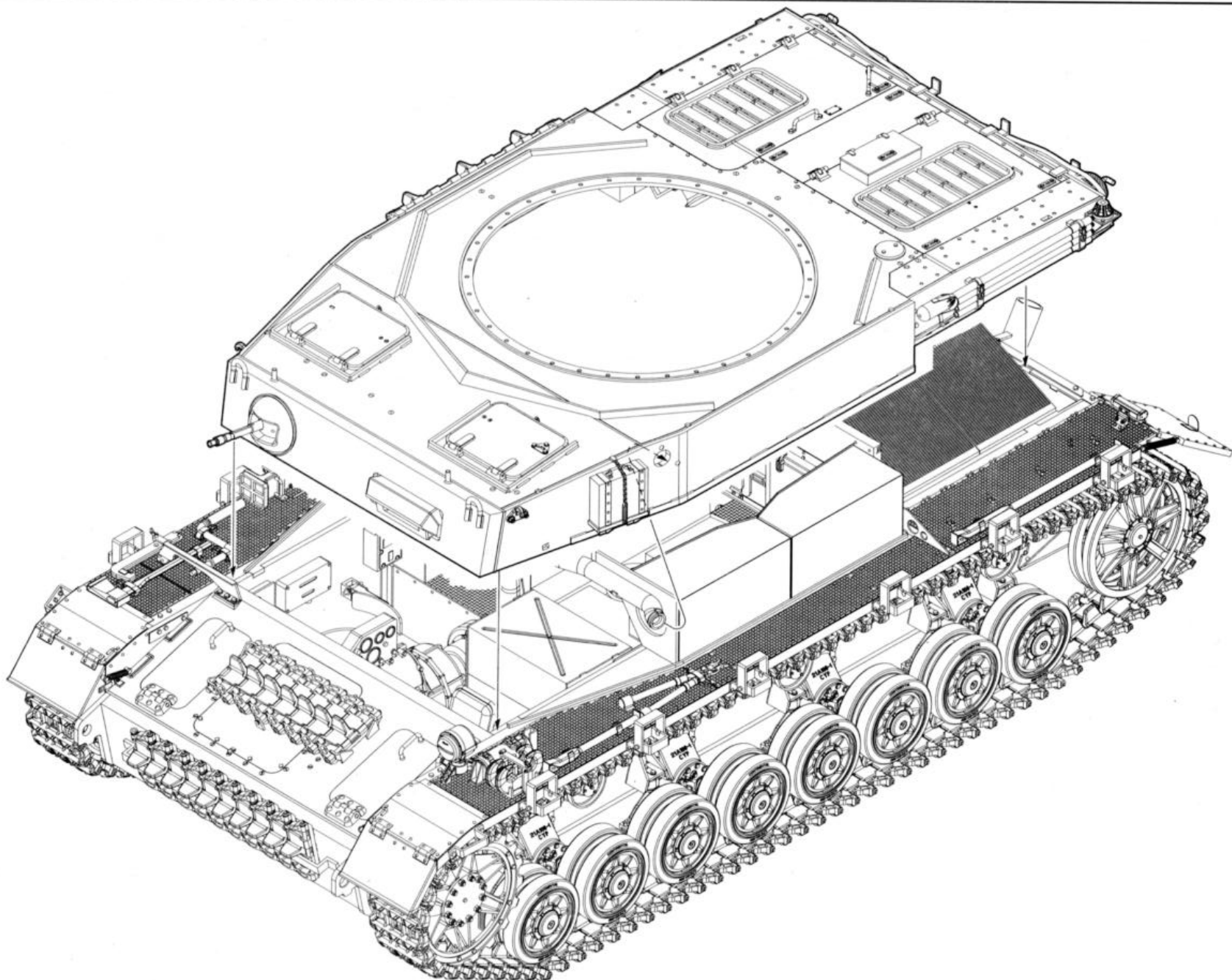

36

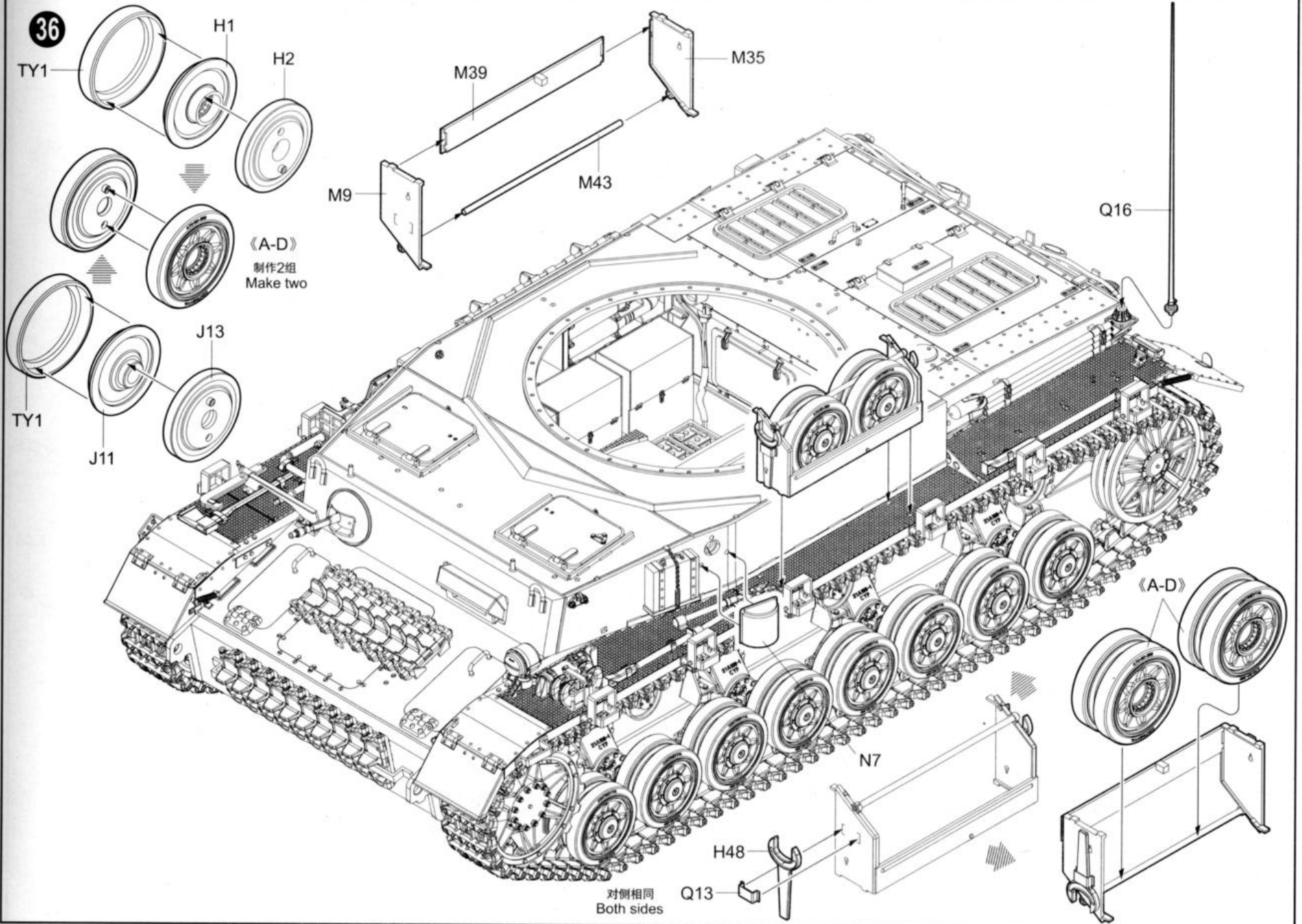

37

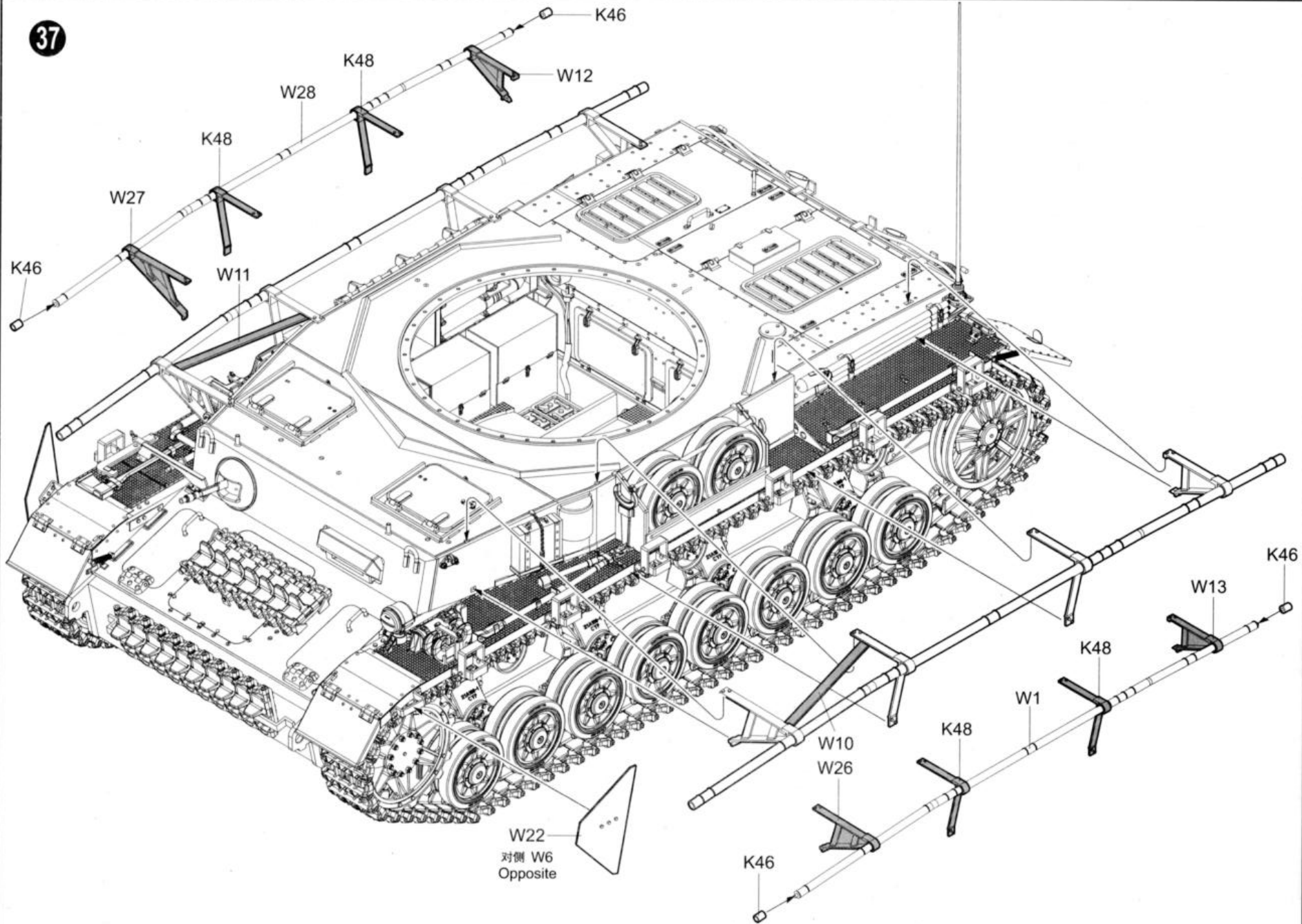

38

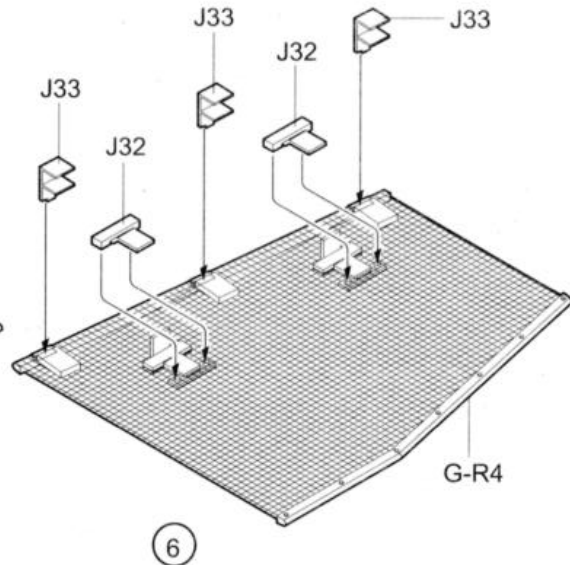
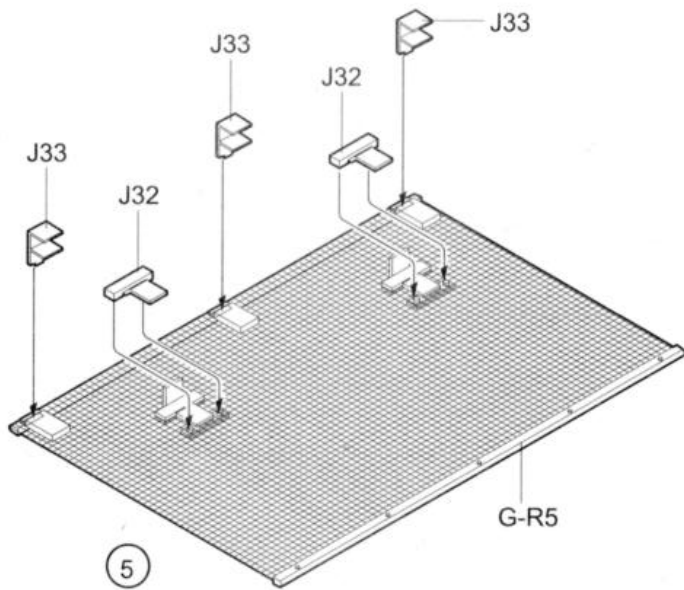
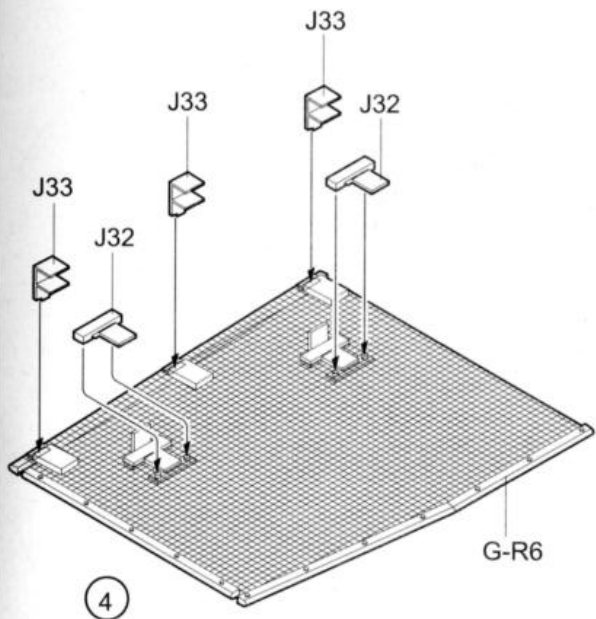
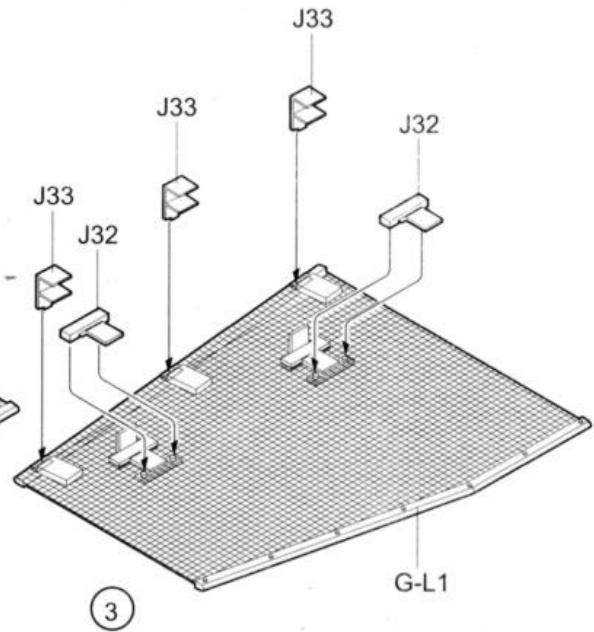
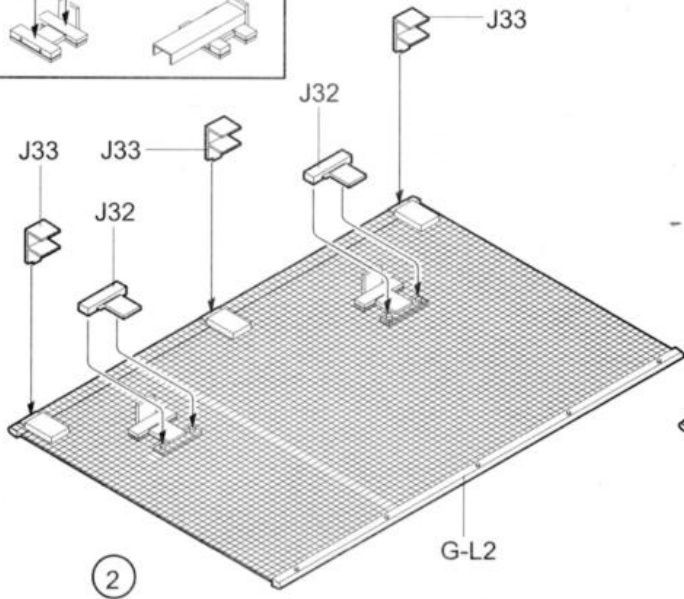
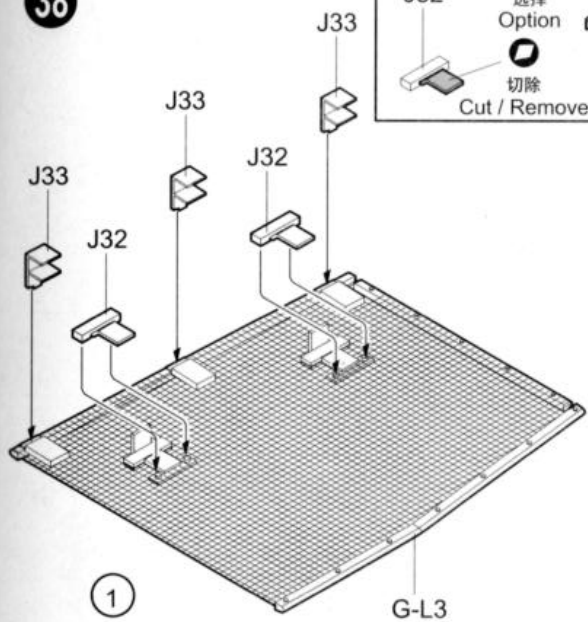
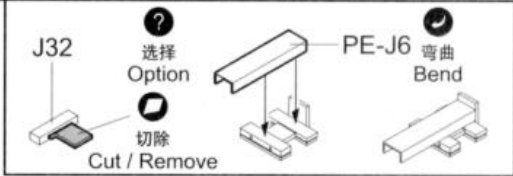

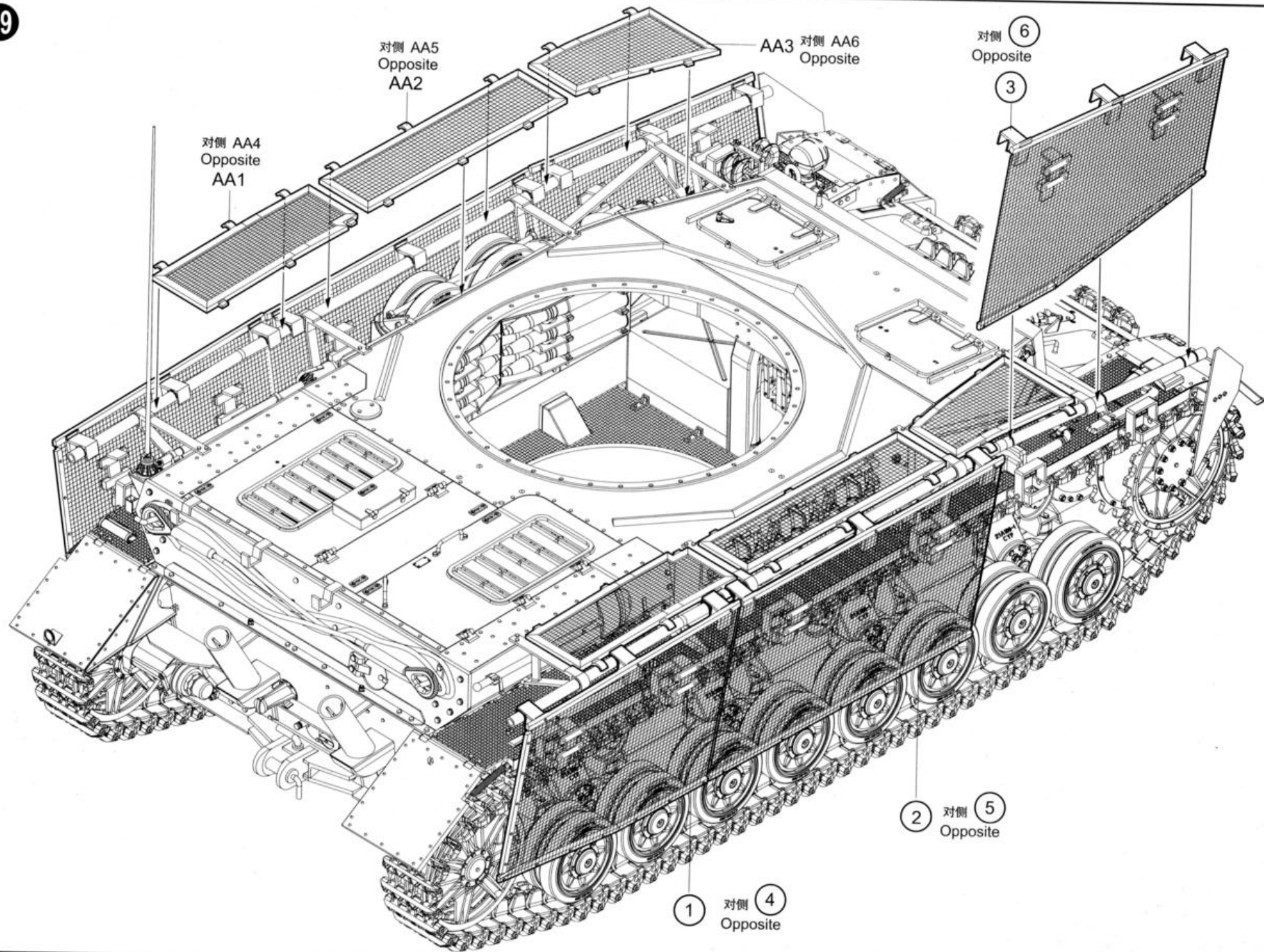

40

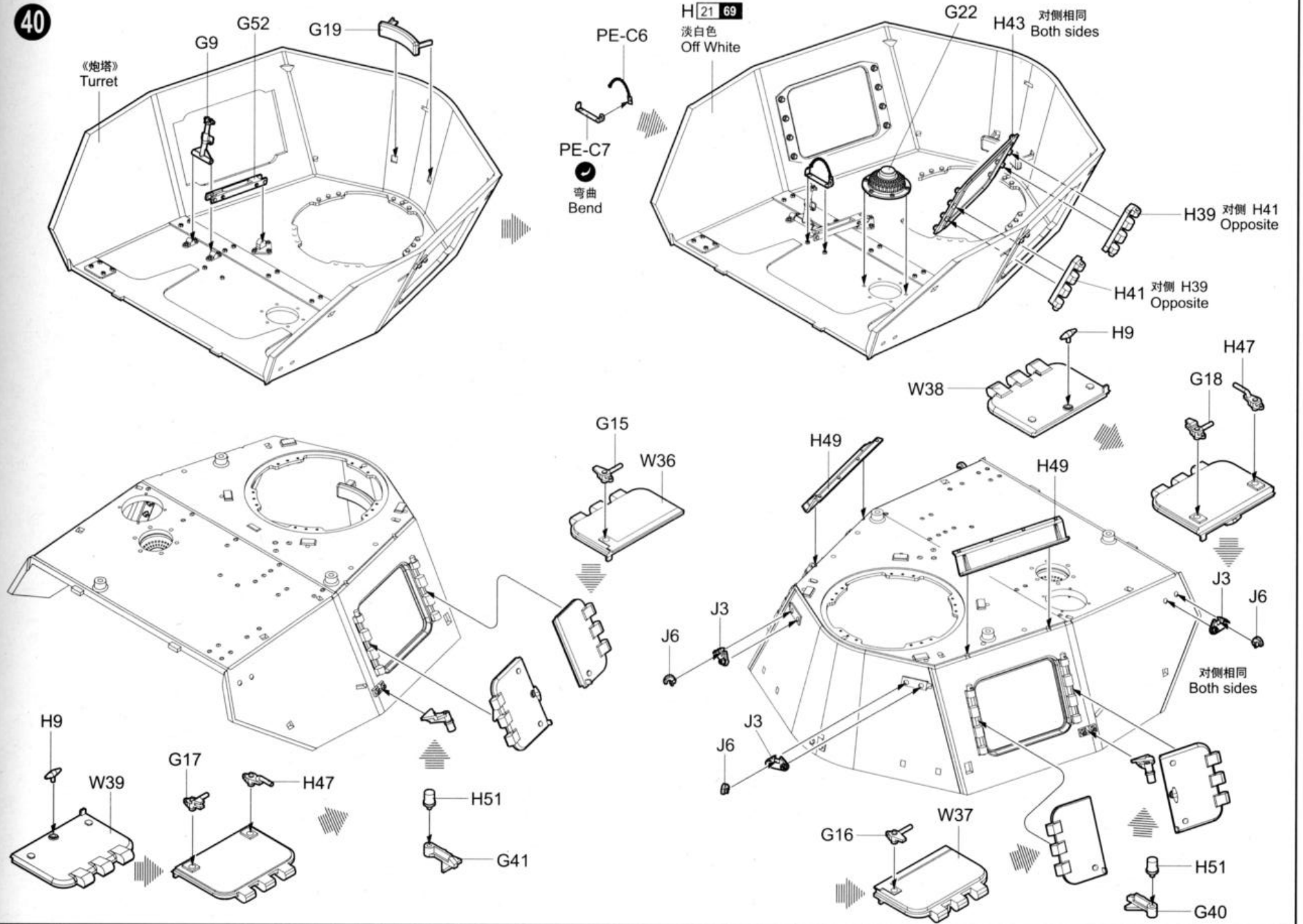

41

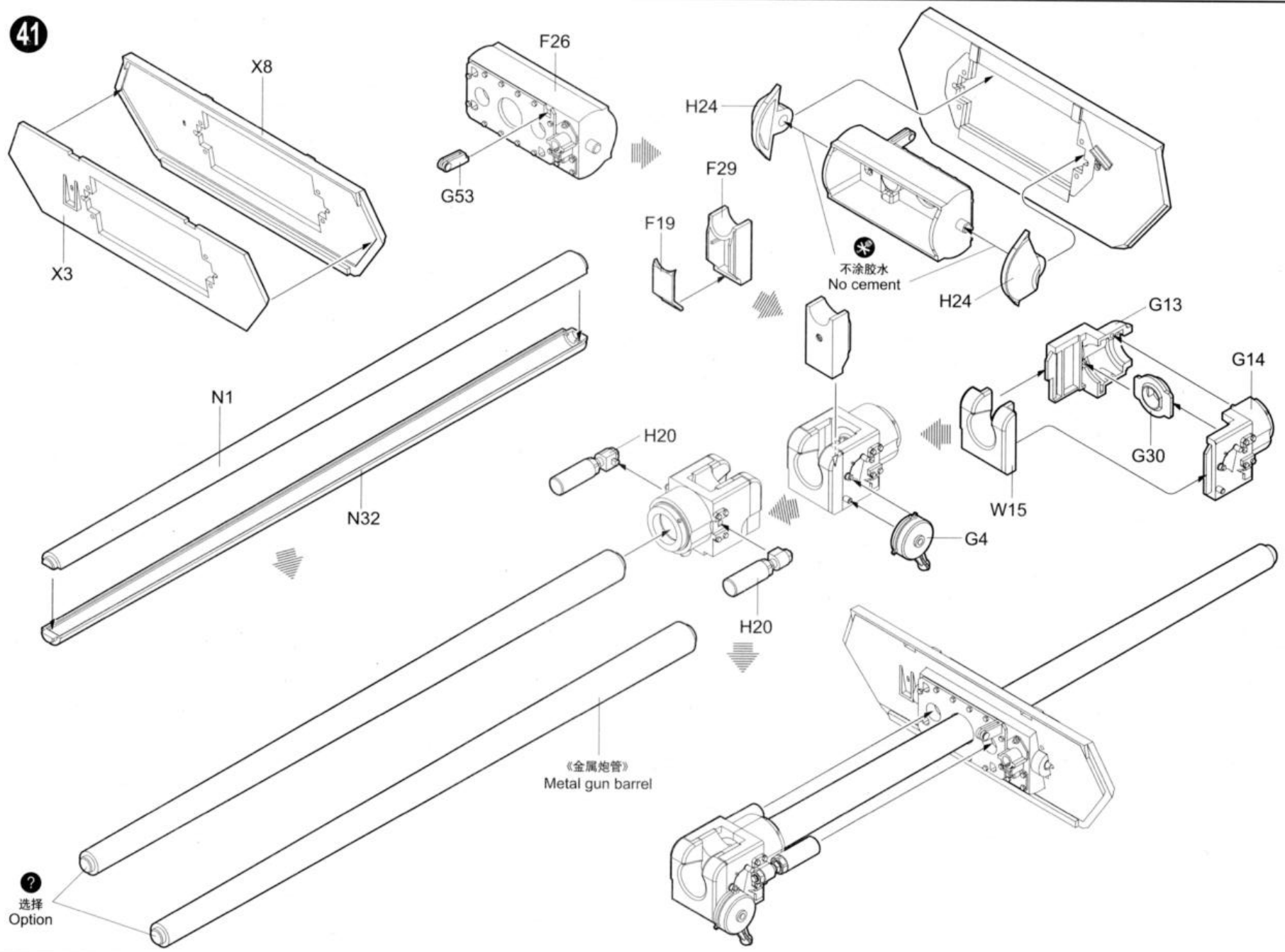

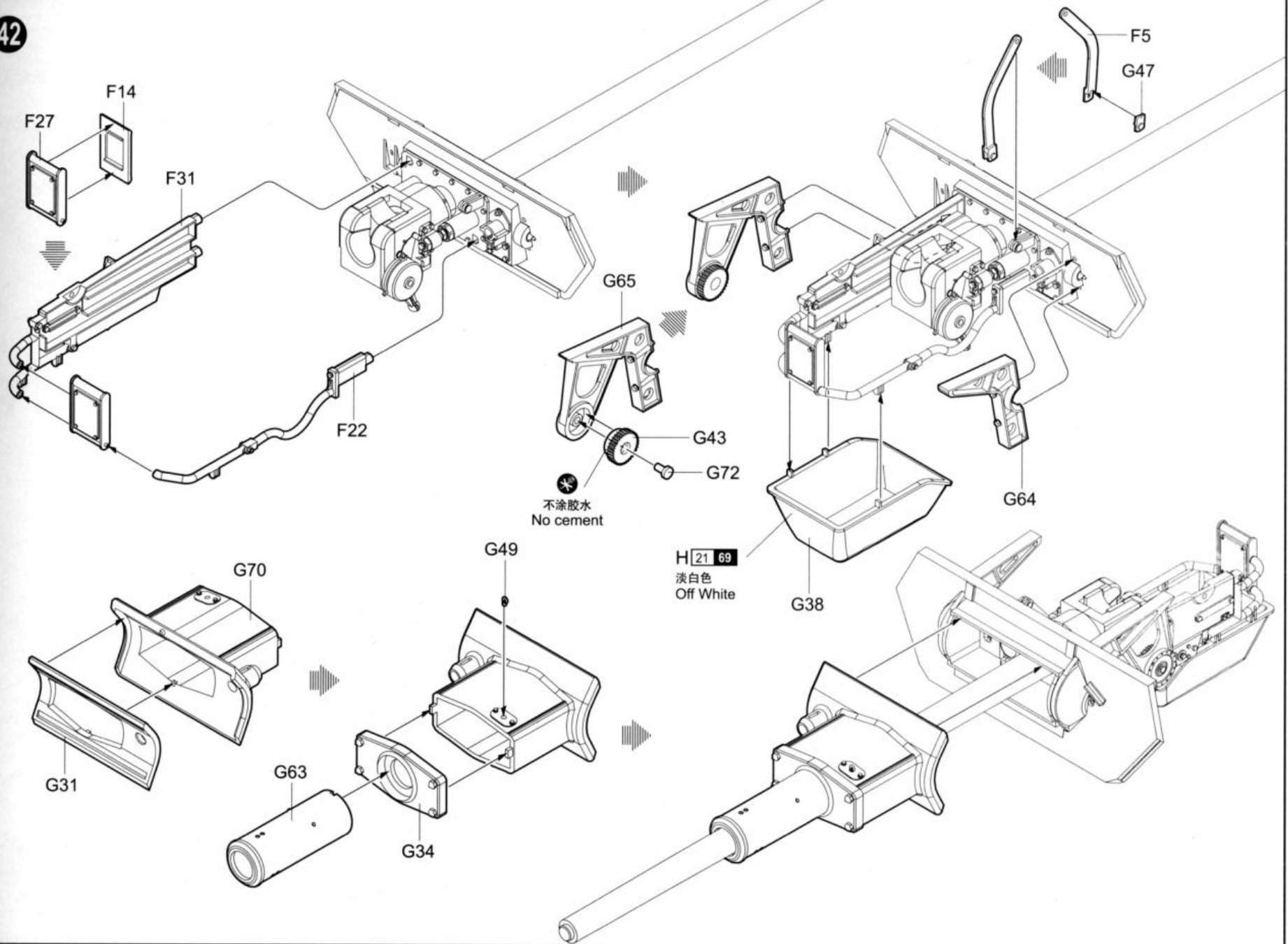

43

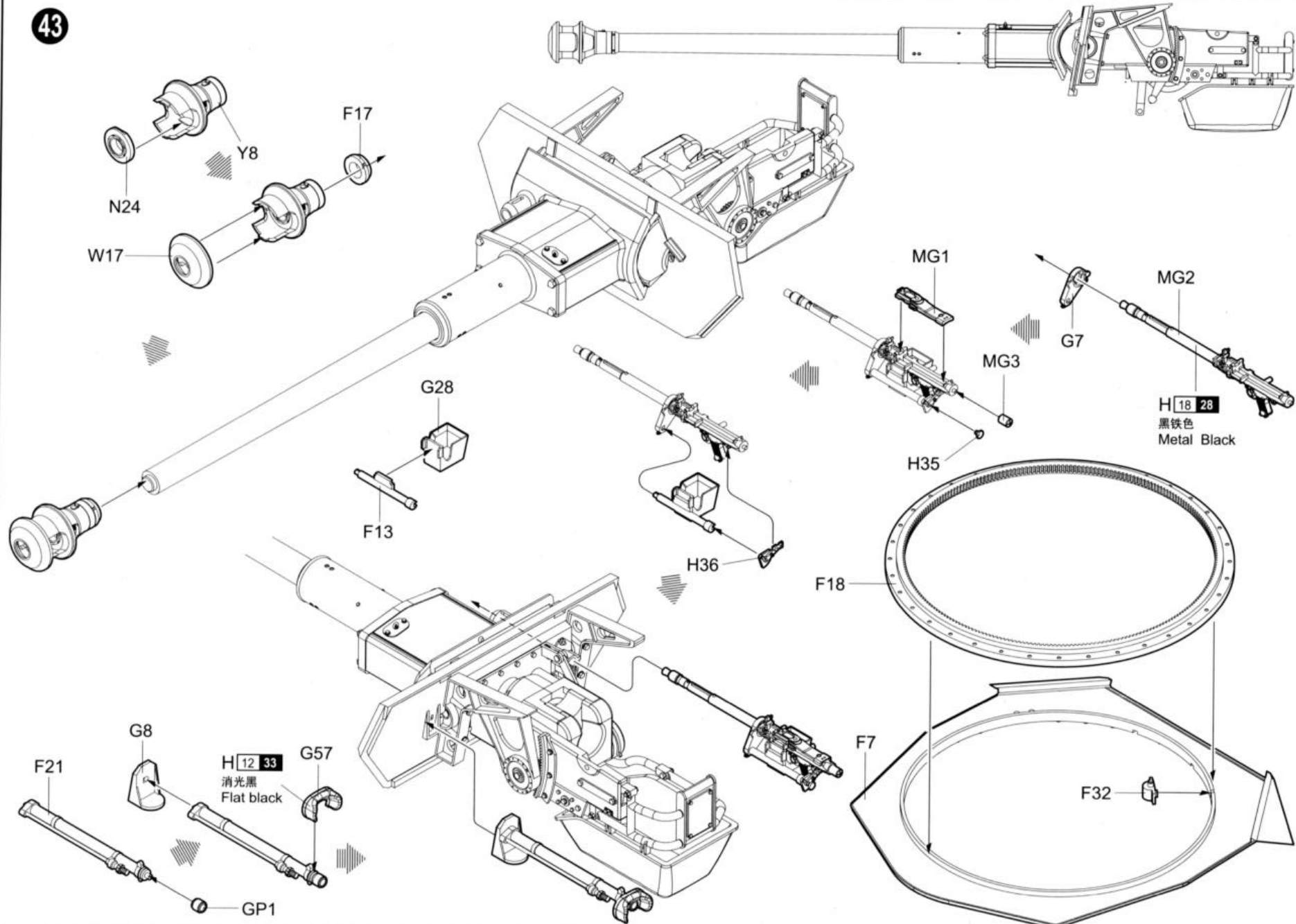

00921

46

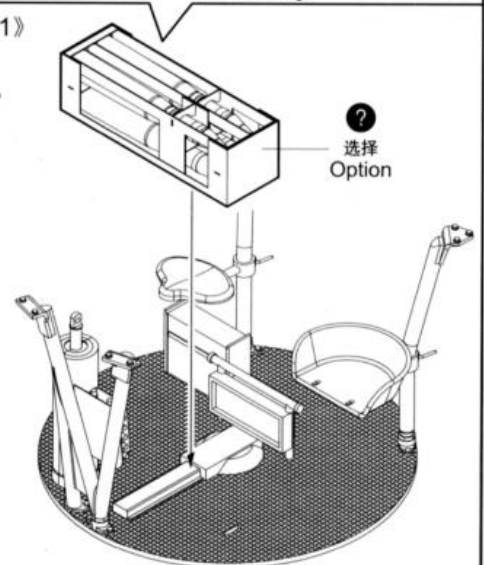
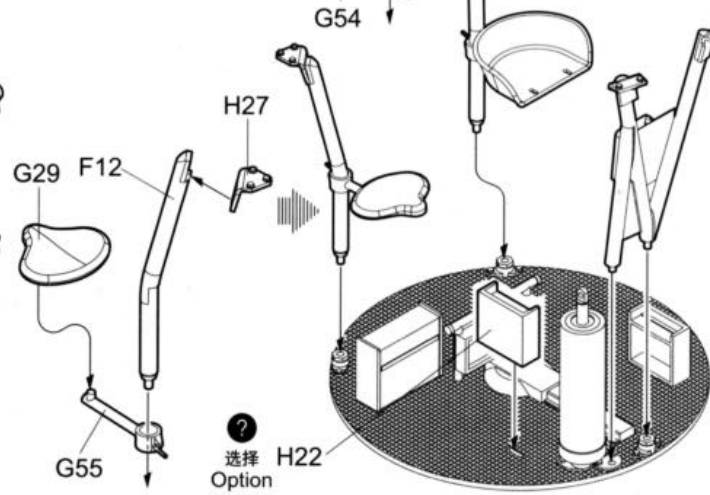
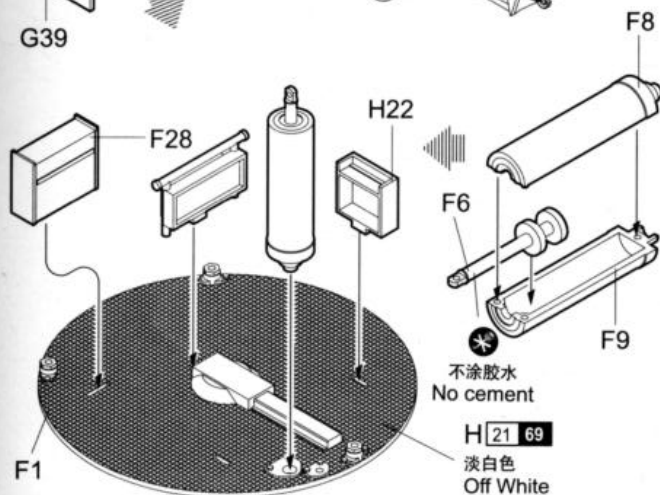
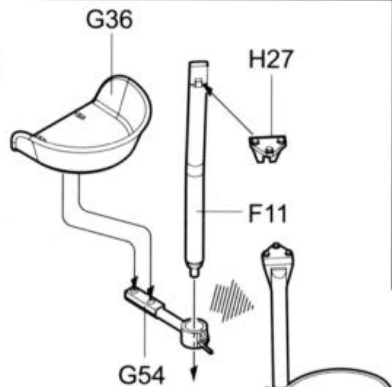
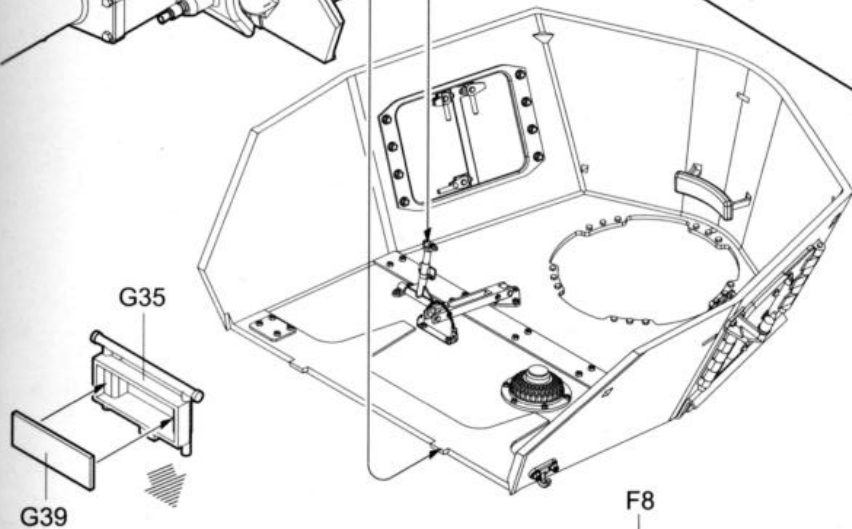
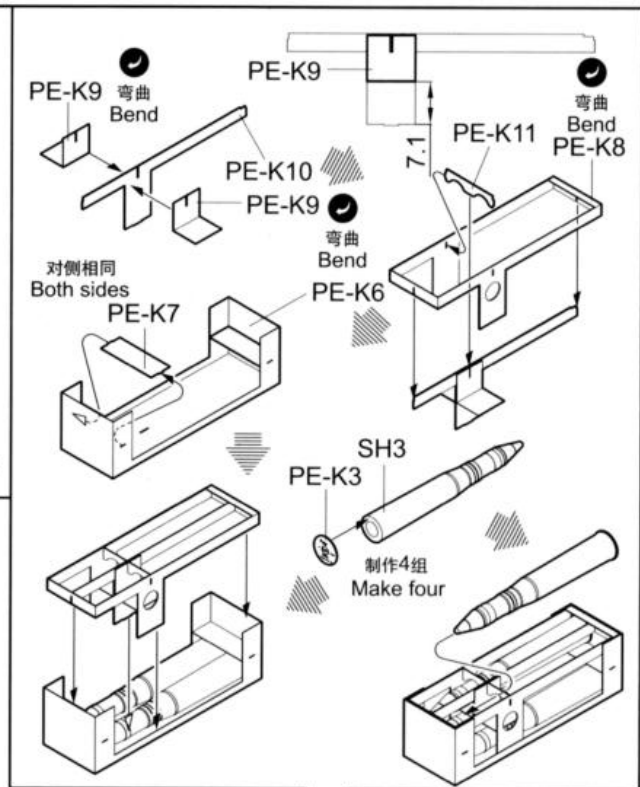
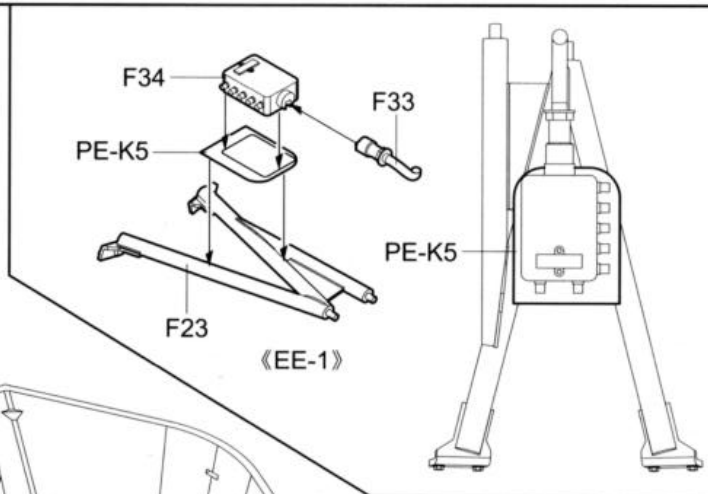
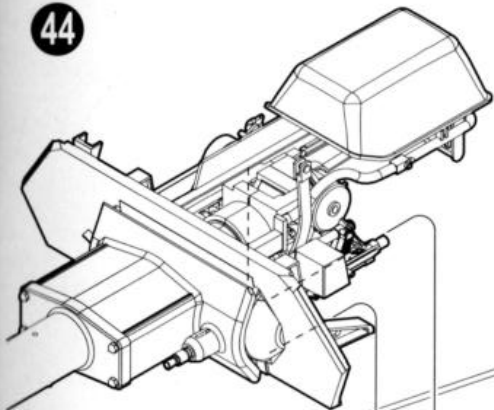

45

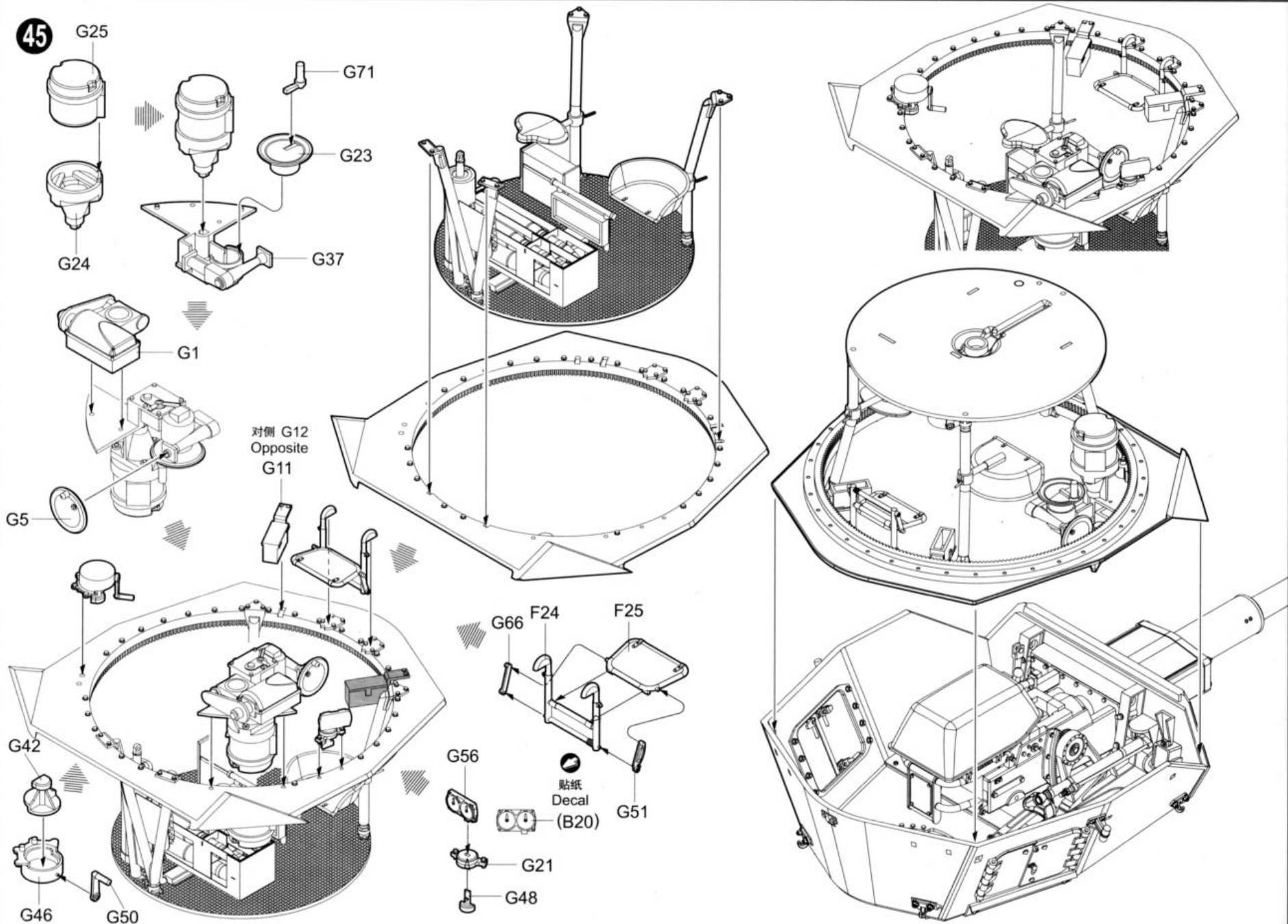

对侧 G12
Opposite
G11

贴纸
Decal

(B20)

46

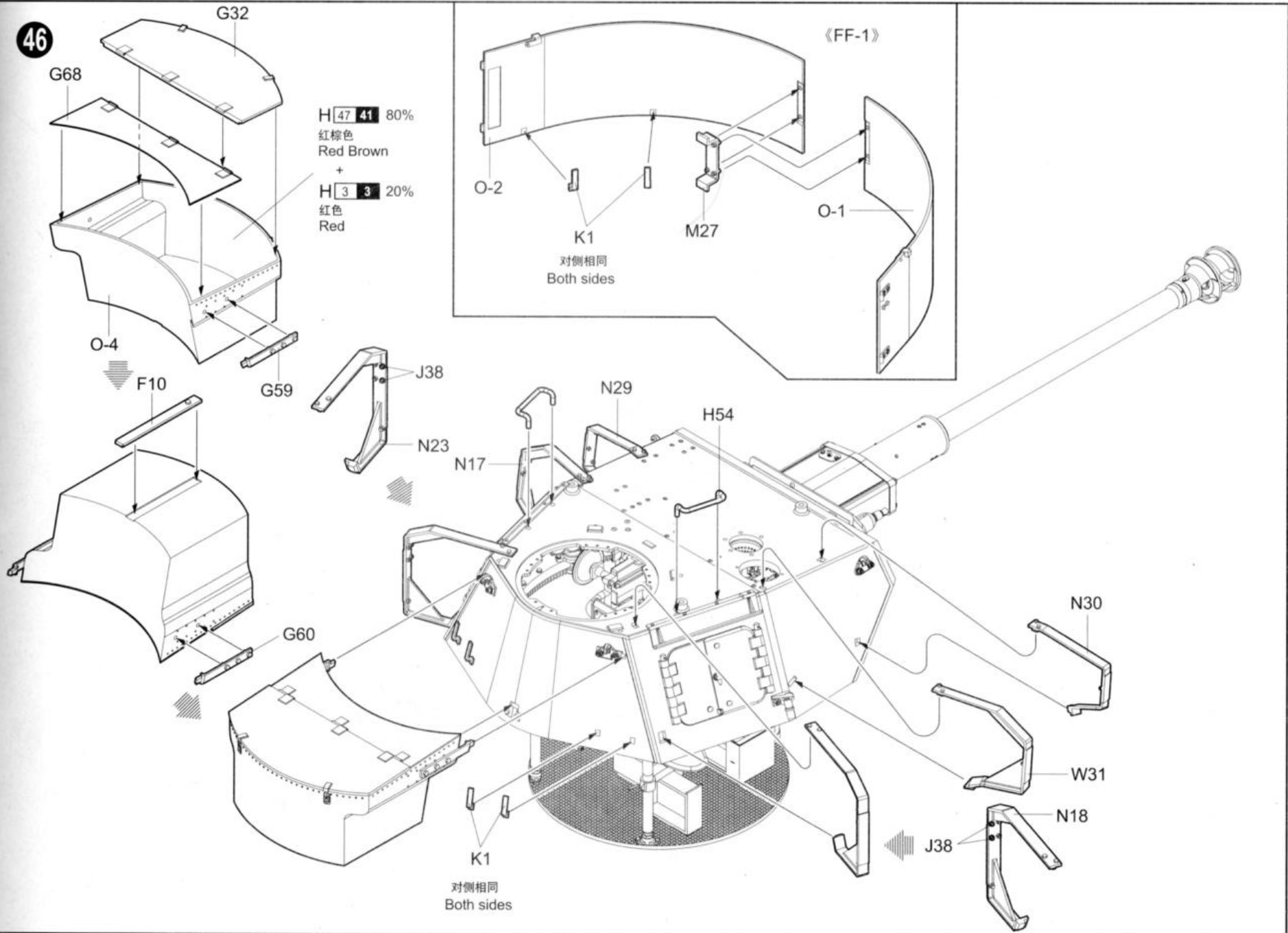

47

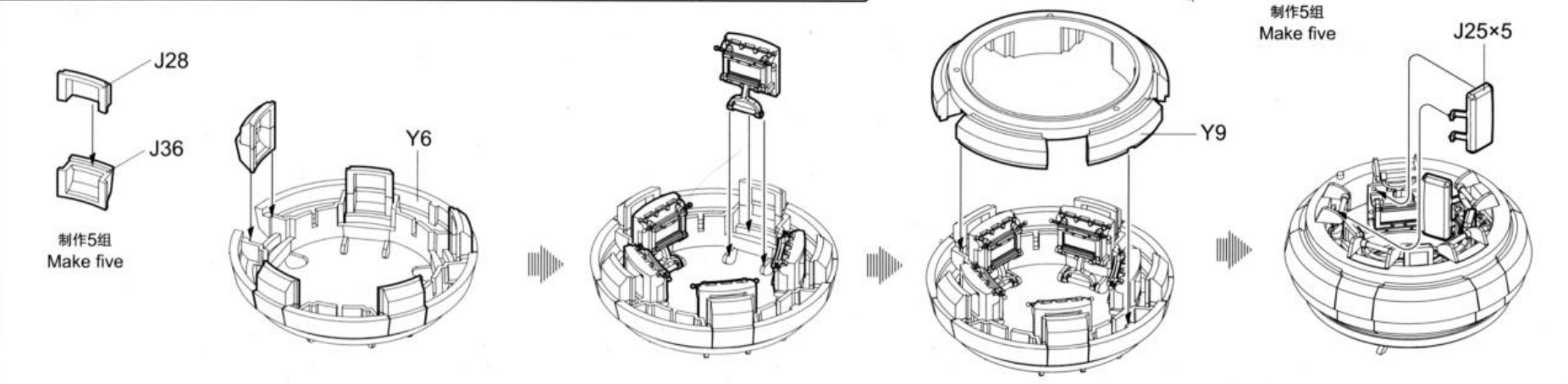
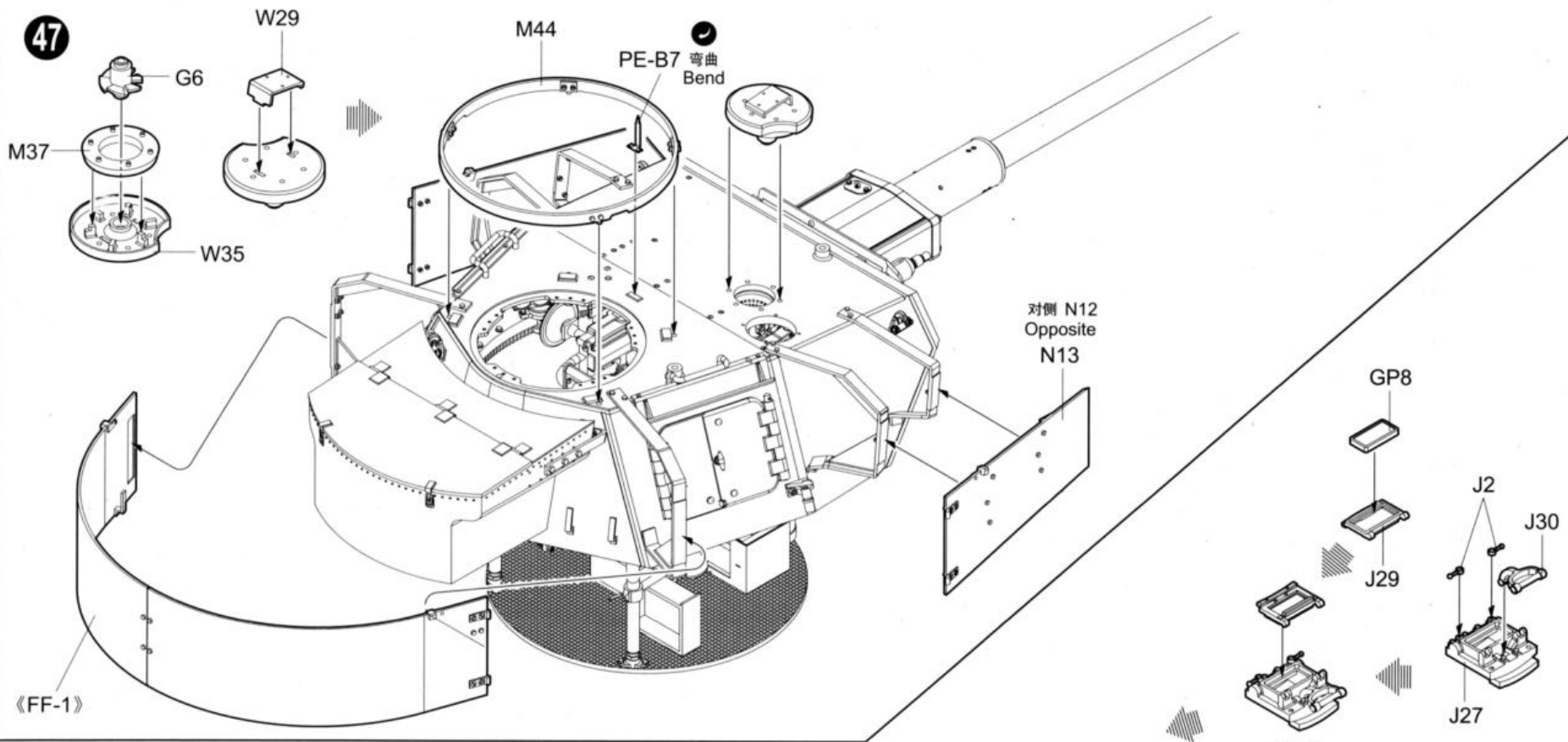

48

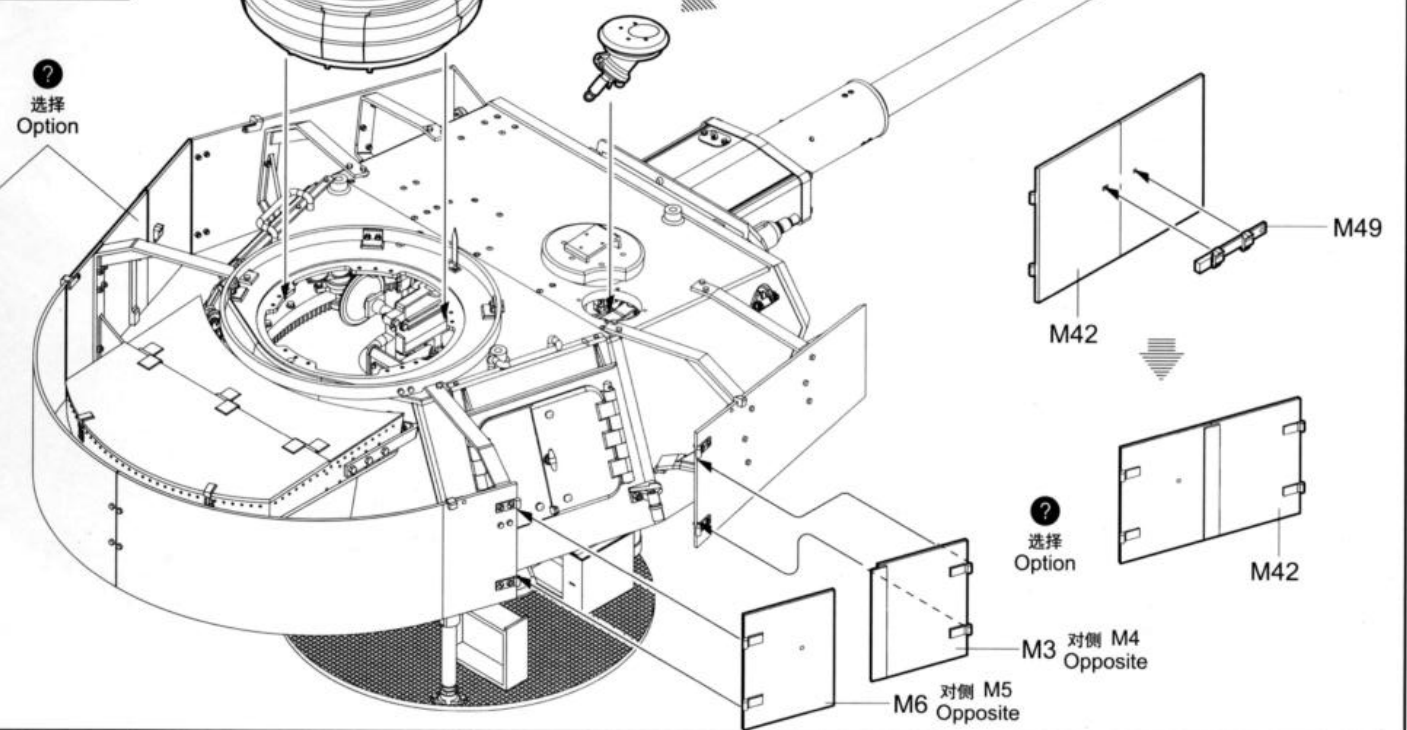
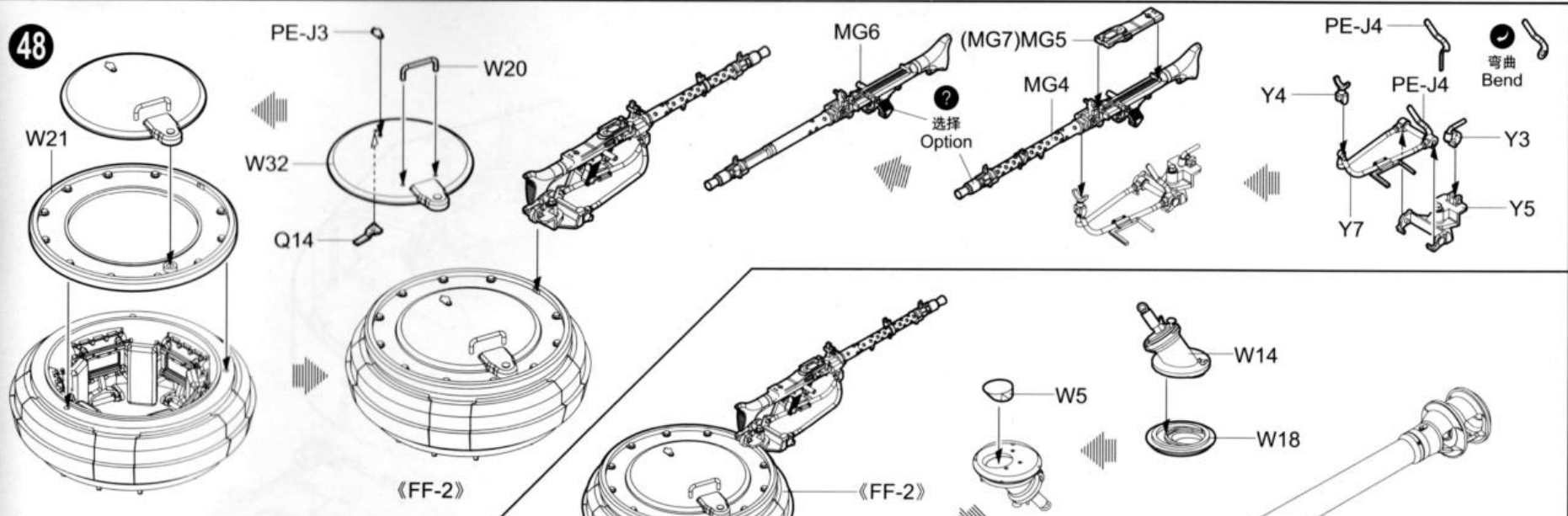

49

对侧 PE-J1
Opposite
PE-J2

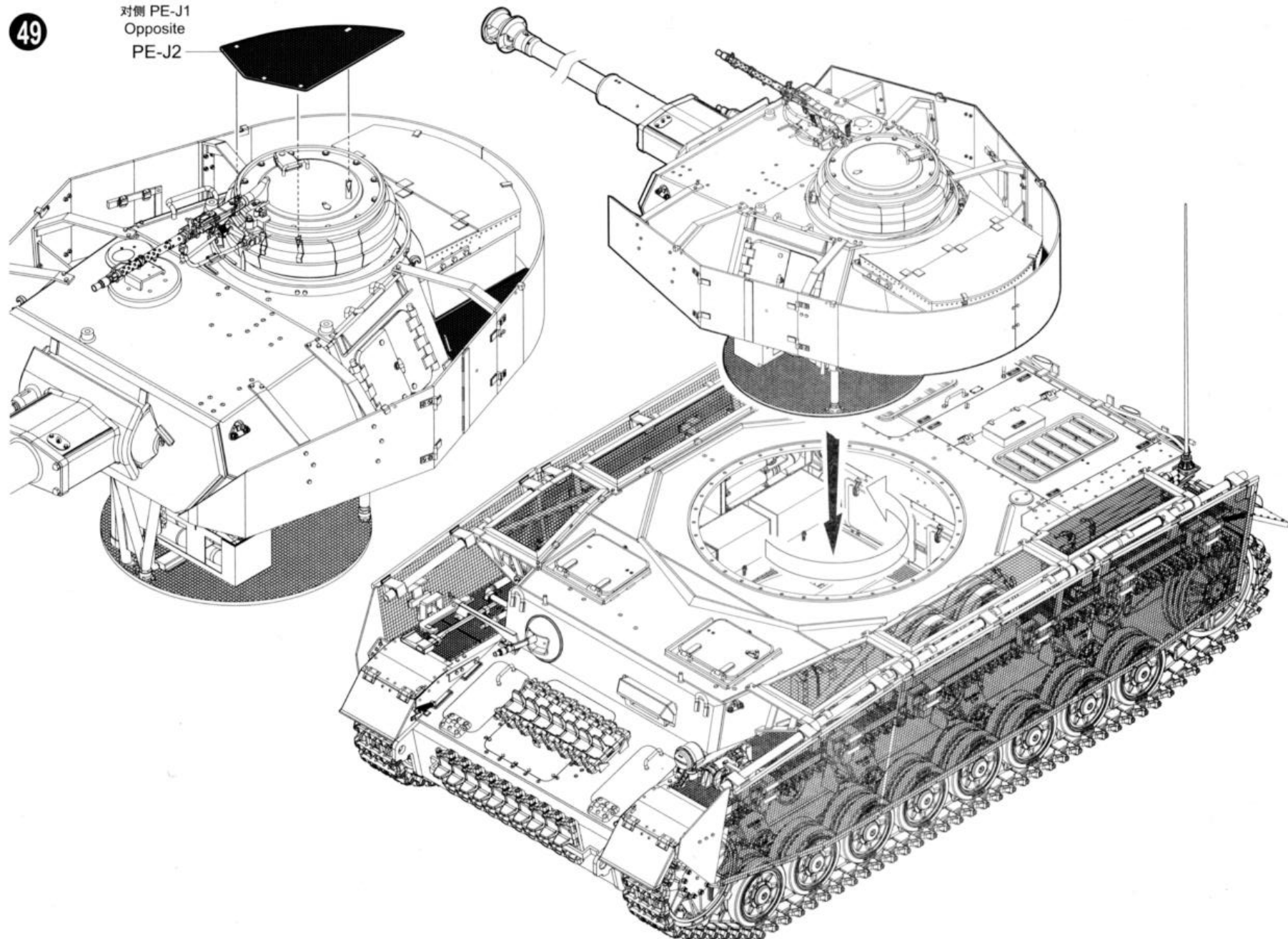

涂装同标贴指示

Painting & Marking guide

PAINT REFERENCE COLOUR

Color	Mr.Hobby	Vallejo	Model Master	Tamiya	Humbrol
Burnt Iron 烧铁色	H 76 61	863	1795	X10	53
Tire Black 胎黑色	H 77 137	-	-	-	-
Wood Brown 木棕色	H 37 43	983	1701	-	186

PAINT REFERENCE COLOUR

Color	Mr.Hobby	Vallejo	Model Master	Tamiya	Humbrol
Metal Black 黑铁色	H 18 28	864	1402	-	-
Sandy Brown 砂黄色	H 79 39	842	-	XF59	93
Dark Green 暗绿色	H 70	-	-	-	-
Red brown 红棕色	H 47 41	984	-	XF64	160

A

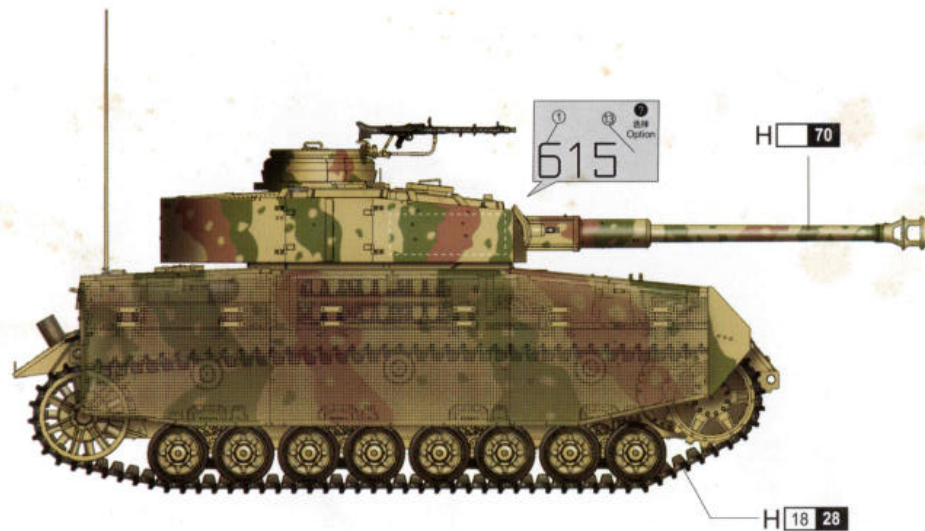
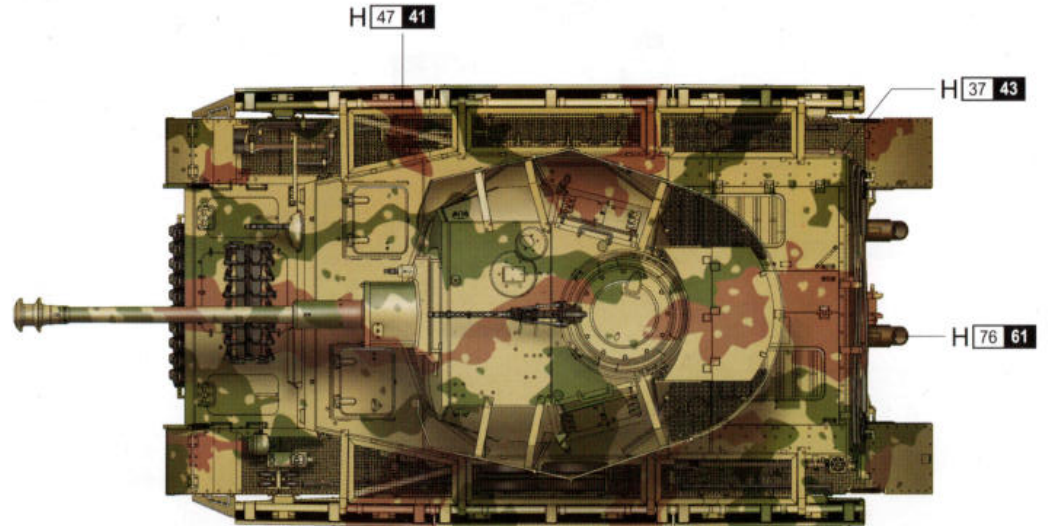
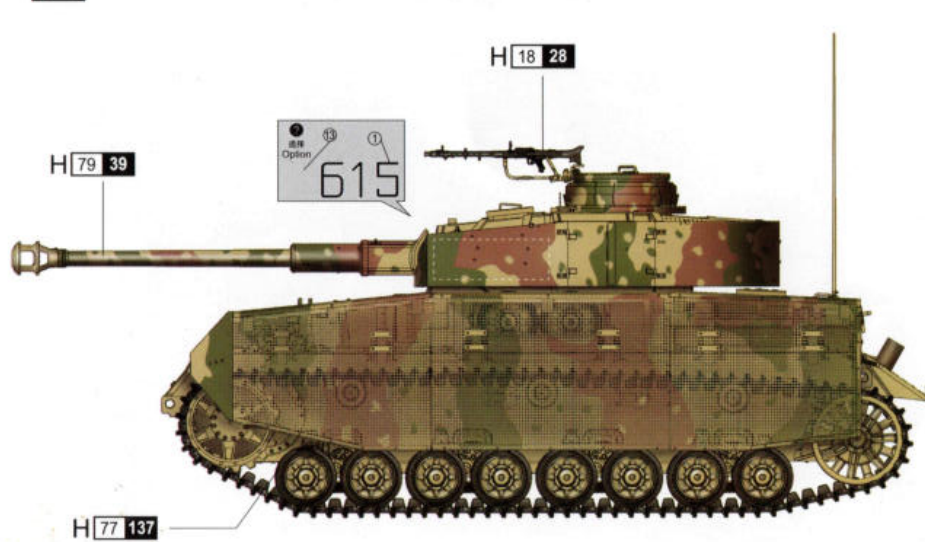

B

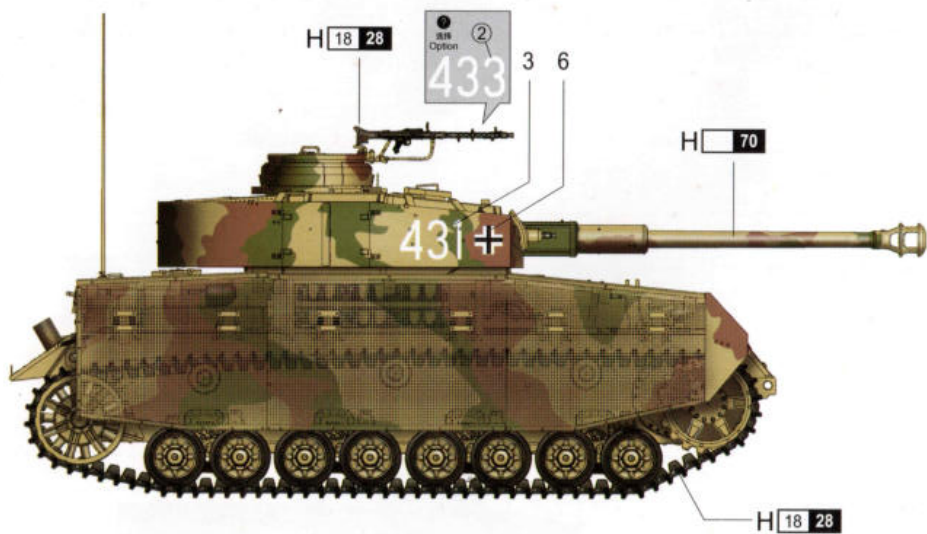
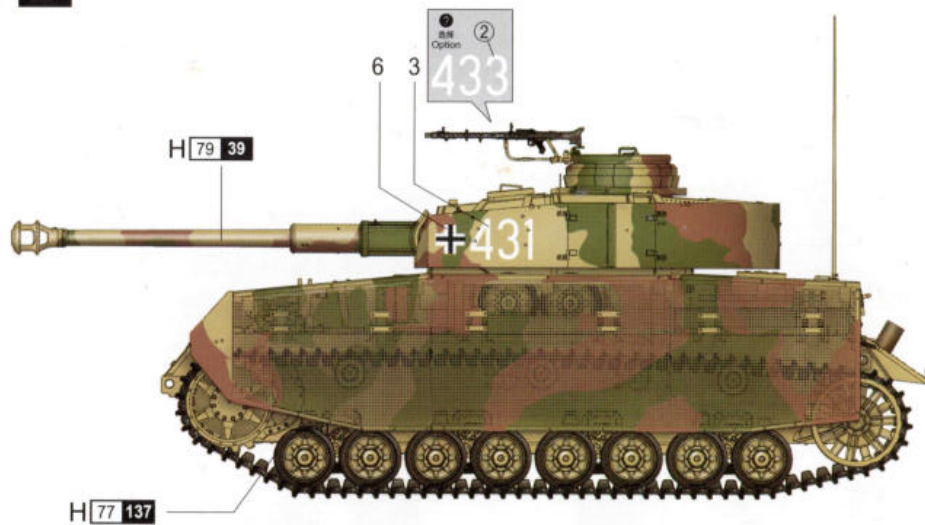

H X AQUEOUS HOBBY COLOR

X Mr. COLOR

00921 1/16 German Pzkwf IV Ausf.J Medium Tank A

涂装同标贴指示 Painting & Marking guide

C

PAINT REFERENCE COLOUR					
Color	Mr.Hobby	Vallejo	Model Master	Tamiya	Humbrol
Burnt Iron 烧铁色	H 76 61	863	1795	X10	53
Tire Black 胎黑色	H 77 137	-	-	-	-
Wood Brown 木棕色	H 37 43	983	1701	-	186
White 白色	H 1 1	842	1745	XF2	22
Copper 铜色	H 10 10	999	1551	XF6	12

PAINT REFERENCE COLOUR					
Color	Mr.Hobby	Vallejo	Model Master	Tamiya	Humbrol
Metal Black 黑铁色	H 18 28	864	1402	-	-
Sandy Brown 砂黄色	H 79 39	842	-	XF59	93
Dark Green 暗绿色	H 70	-	-	-	-
Red brown 红棕色	H 47 41	984	-	XF64	160
Dark Gray 暗灰	H 83 32	-	-	-	-

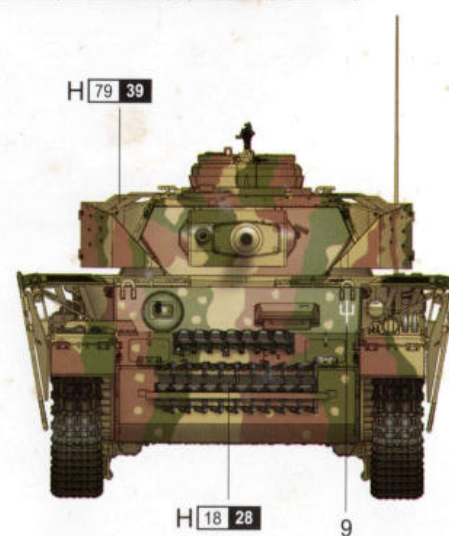
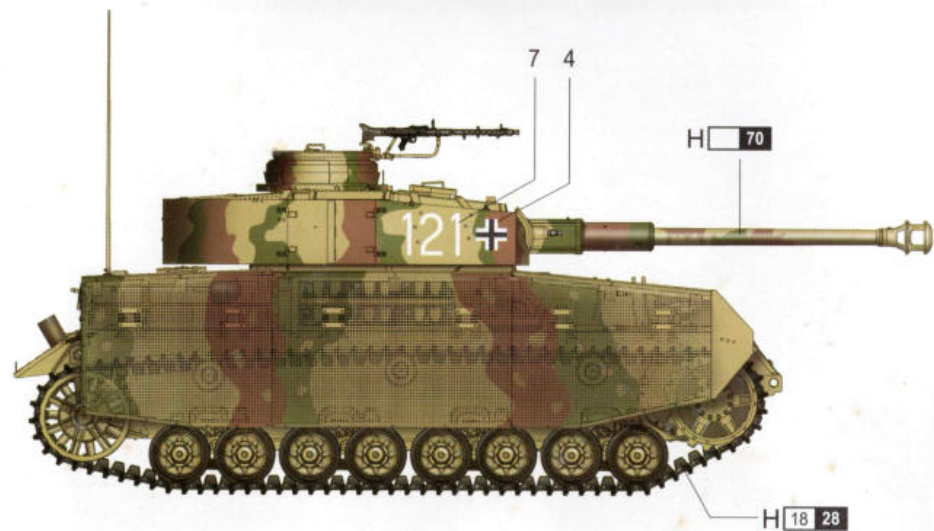
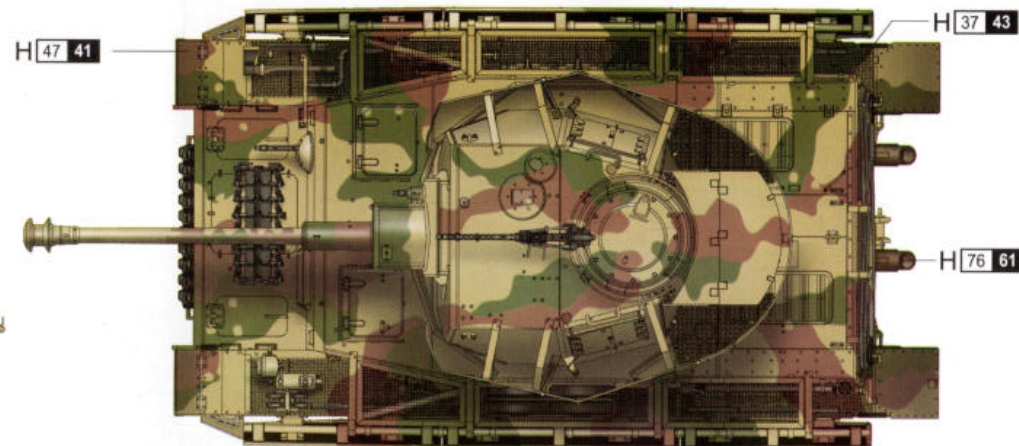
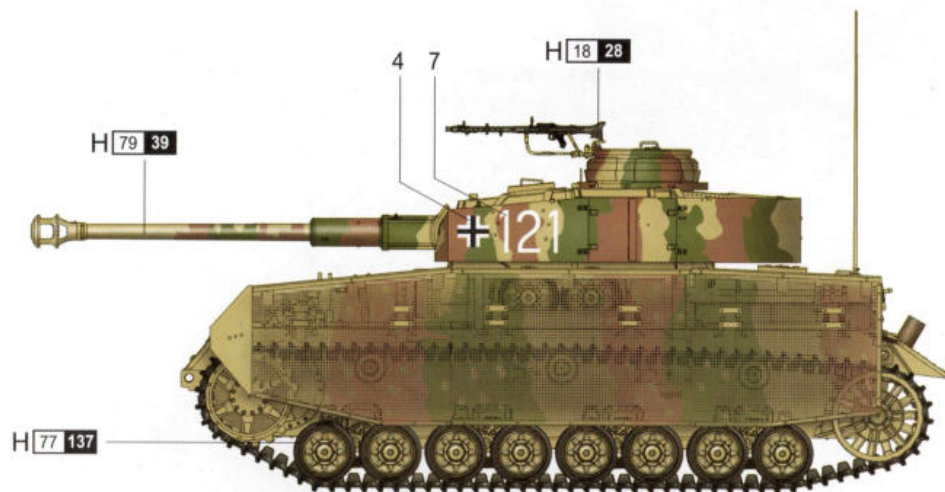

D

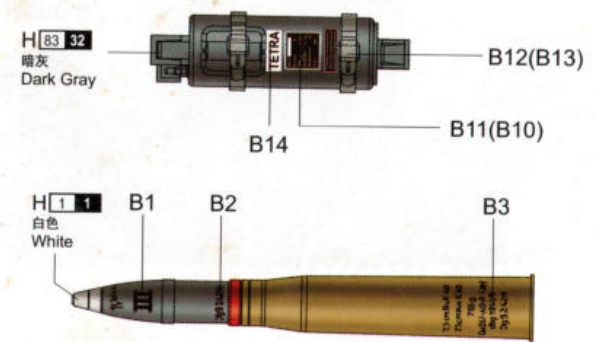
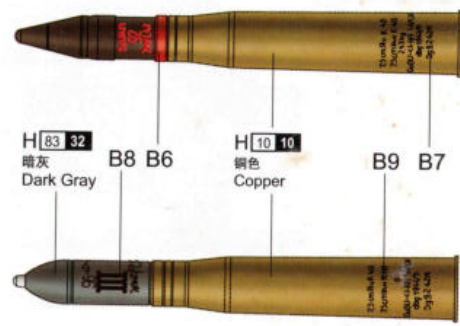
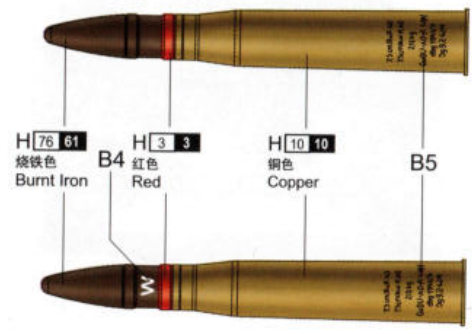
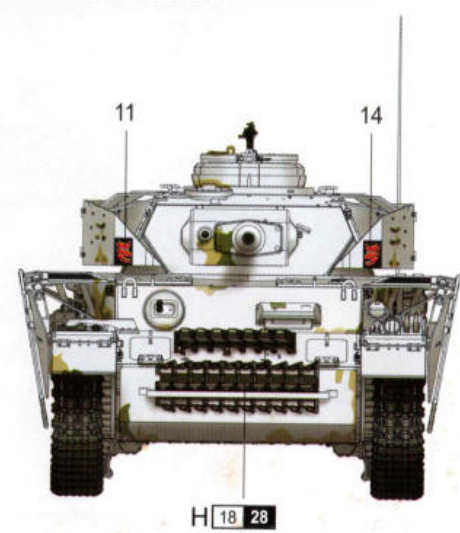
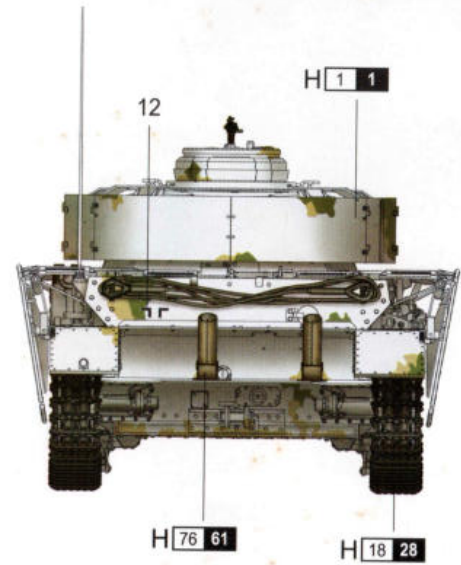
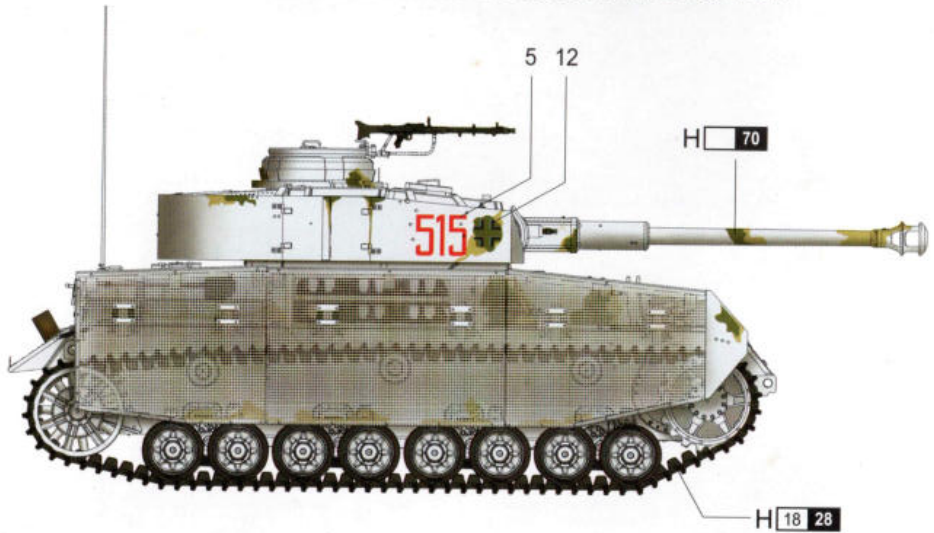
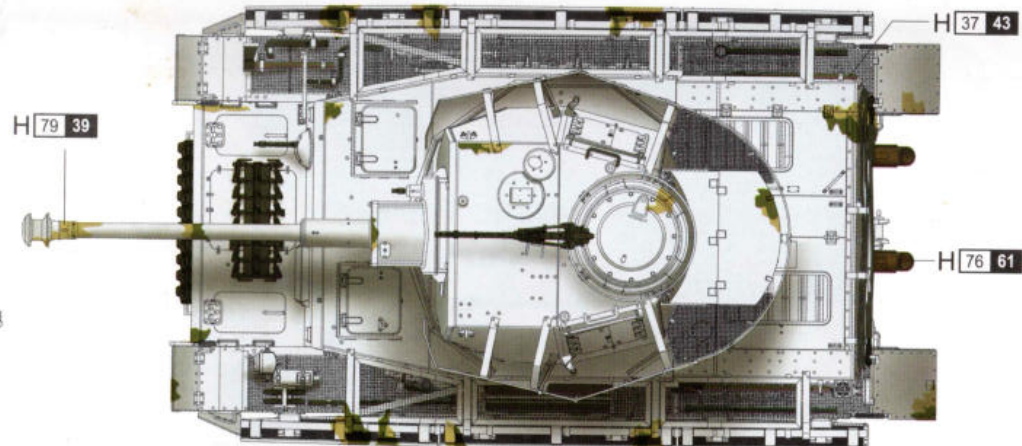

H X AQUEOUS HOBBY COLOR X Mr. COLOR

1/16
scale 00921

German PzKpfw IV Ausf. J Medium Tank



The Panzerkampfwagen IV (Pz.Kpfw. IV) Sd Kfz 161, commonly known as the Panzer IV, was a medium tank developed in Nazi Germany in the late 1930s and used extensively during the Second World War. Its ordnance inventory designation was Sd.Kfz. 161.

Designed as an infantry-support tank, the Panzer IV was not originally intended to engage enemy armour—that function was performed by the lighter Panzer III. However, with the flaws of pre-war doctrine becoming apparent, and in the face of Soviet T-34 tanks, the Panzer IV soon assumed the tank-fighting role of its increasingly obsolete cousin. The most widely manufactured and deployed German tank of the Second World War, the Panzer IV was used as the base for many other fighting vehicles, including the Sturmgeschütz IV tank destroyer, the Wirbelwind self-propelled anti-aircraft weapon, and the Brummbar self-propelled gun, amongst others.

The kit consists of 1806 parts on 82 sprues, 238 parts photo-etched, 1 metal barrel, 4 spring, 2 metal shaft and 1 copper cable.

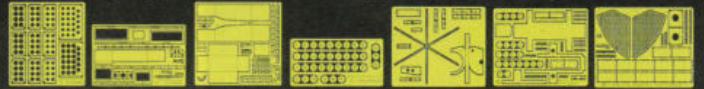

Well detailed front and rear hulls.

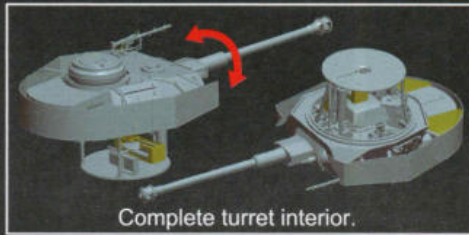

Complete turret interior.

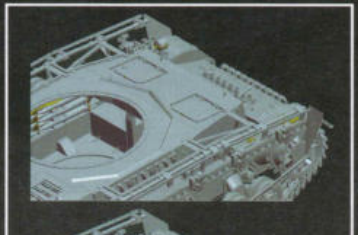

Driver and bow gunner hatches can be opened or closed.

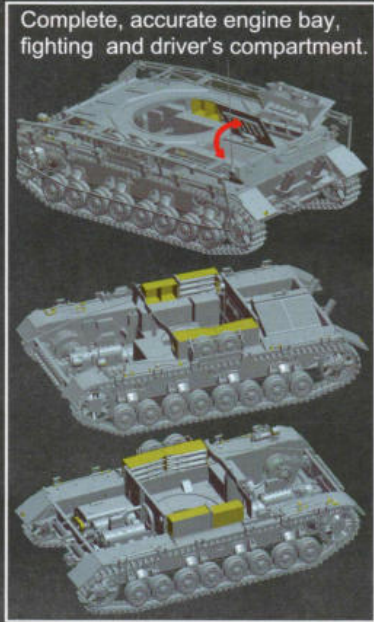

Complete, accurate engine bay, fighting and driver's compartment.

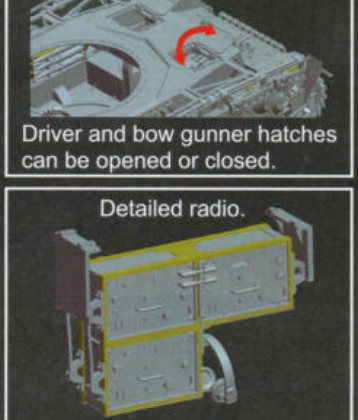
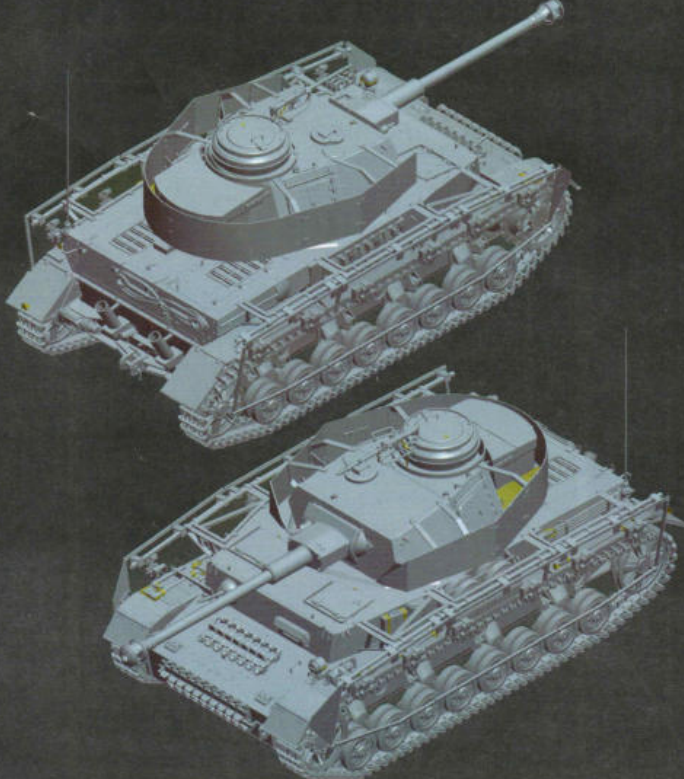

Detailed radio.



Accurate fuel tank.

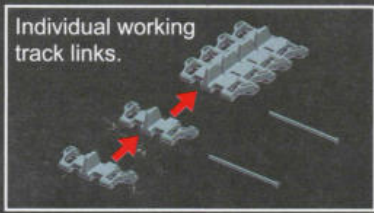

Individual working track links.

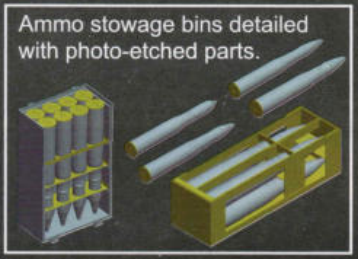

Ammo stowage bins detailed with photo-etched parts.

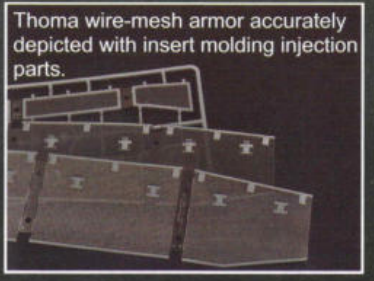

Thoma wire-mesh armor accurately depicted with insert molding injection parts.



Detailed engine.



Accurate, working running gear and suspension.



Hull floor and transmission well rendered.

 Trumpeter_Hobbyboss
 Trumpeter_Hobbyboss
 trumpeter&hobbyboss fan club
 小号手模型

