

WWII GERMAN HEAVY TANK

KING TIGER INITIAL PRODUCTION

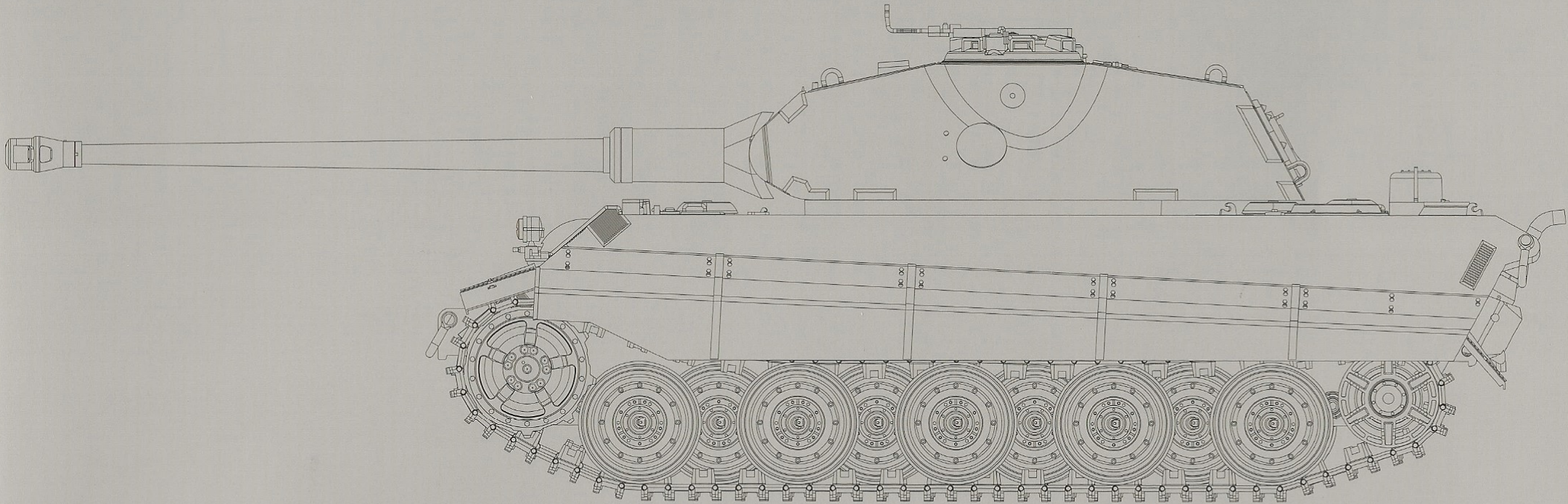

The German Tiger Ausf. B, or King Tiger was arguably the very best tank that was put onto the battlefield during WWII, as well as the costliest. With each unit requiring some 300,000 skilled man-hours to complete, the King Tiger went into serial production in December 1943 at the Henschel factory in Kassel. At the peak of production, it took only 14 days to complete, and by the end of the war 492 examples were ultimately produced.

With frontal armor reaching up to 150mm thick and side armor 80mm thick, this nearly 70 ton tank was built around the famous dual-purpose semi-automatic 88mm canon firing armor-piercing or high explosive rounds, the KwK 43 (L71) produced by Krupp, with the T.Z.F.9b/1 binocular gun sight (later followed by the monocular T.Z.F.9d) built into the cradle. This set-up allowed the tank to engage virtually any enemy tank before it could come within firing range. The King Tiger with Porsche turret carried a maximum combat load of 80 rounds of ammunition. Additional armament came in the form of 3 Rheinmetall Maschinengewehr 34's with 5800 rounds: one mounted in a kugelblende on the right bow position, one mounted coaxially to the main gun, and one mounted externally to the commander's cupola.

This massive tank was mobilized by a OLVAR EG40 12 16B mechanical transmission with 8 forward and 4 reverse gears powered by a 690hp Maybach HL230 P30 gasoline engine, with a top speed of 25.8 mph (41.5 km/h). The crew of 5 consisted of the tank commander, the loader, the gunner, the driver, and the radio operator.

The King Tiger dominated the battlefield in terms of capabilities, but often suffered from shortages of lubricants & fuels. These tanks proved themselves in battles ranging from Normandy, the Ardennes, Lake Balaton, and Berlin. Although they lived up to the expectations of the 'Wunderwaffe', the King Tigers were ineffective in stopping the overwhelming numbers of opponents they faced on the battlefield. Today there are a total of 11 King Tigers preserved around the world, with the rest having been long lost to the scrap yards.

READ BEFORE ASSEMBLY

CAUTION

- Read carefully and fully understand the instructions before commencing assembly. A supervising adult should also read the instructions if a child assembles the model.
- When assembling this kit, tools including knives used. Extra care should be taken to avoid personal injury.
- Keep out of reach of small children. Children must not be allowed to suck any part, or pull vinyl bag over their heads.



Optional



Fill Holes



Be Careful



Remove



Drill



Instant Glue
for Metal

PAINTS REQUIRED

Color info and profiles by Mig Jimenez

A.MIG 035	Dark Tracks	A.MIG 037	New Wood	A.MIG 043	Gun Metal	A.MIG 096	Crystal Periscope Green
A.MIG 040	Medium Rust	A.MIG 010	Dunkelgelb (Mid War)	A.MIG 014	Rotbraun	A.MIG 097	Grey Dark Base
A.MIG 008	Dunkelgrau						

APPLYING DECALS

1. Clean the model surface with a wet cloth.
2. Cut out each decal design from sheet, and dip it in tepid water for 15~20 sec.
3. Hold the backing sheet edge and slide decal onto the model.
4. Move decal into position by wetting decal with finger.
5. Press decal gently down with a soft cloth until excess water and air bubbles are gone.

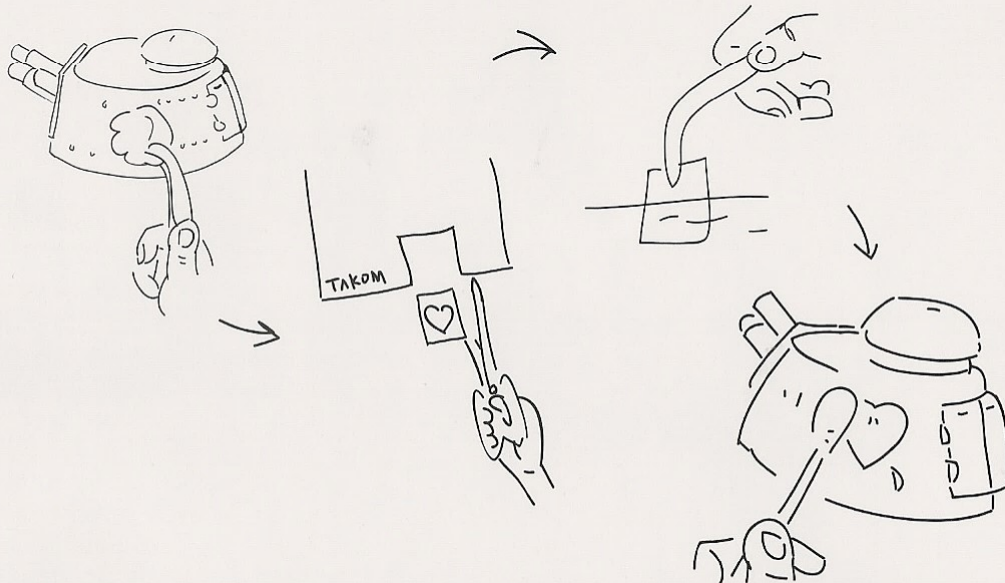

REMOVING PE

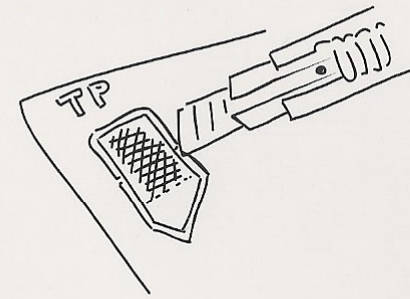

Be careful not to hurt when removing PE parts.

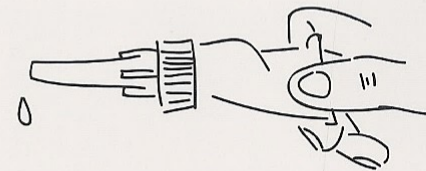

Secure using instant glue (not included).

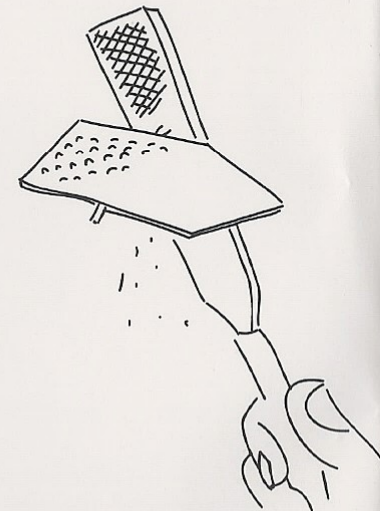

Finish using file.

PARTS

X4

X2

Decal

Upper Hull

Lower Hull

TP

Turret

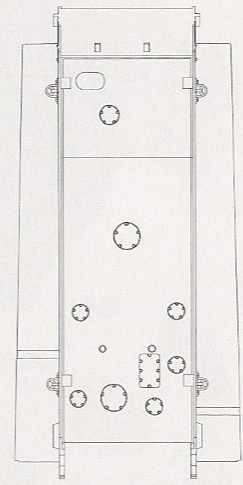
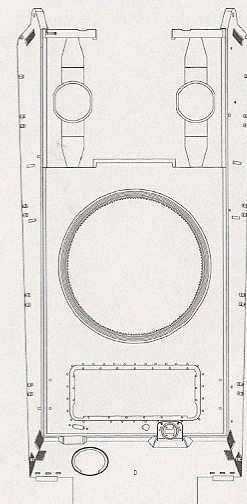
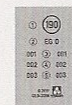
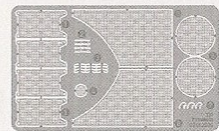
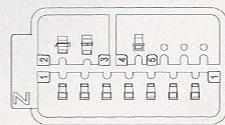
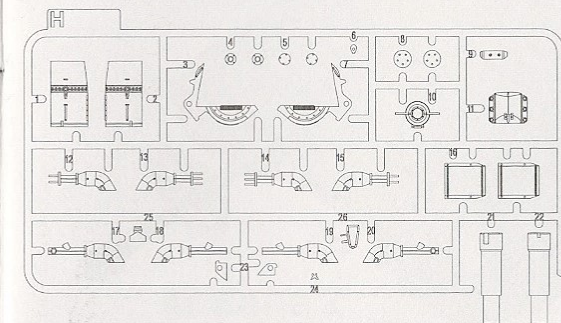
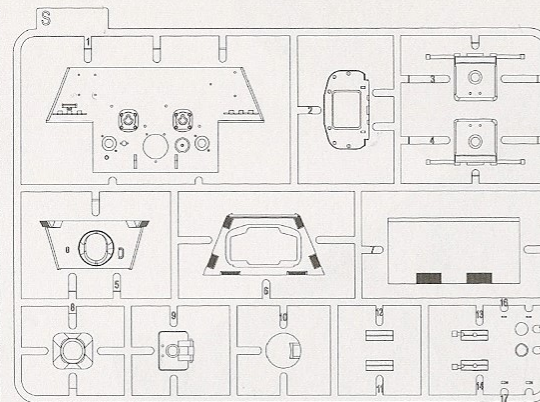
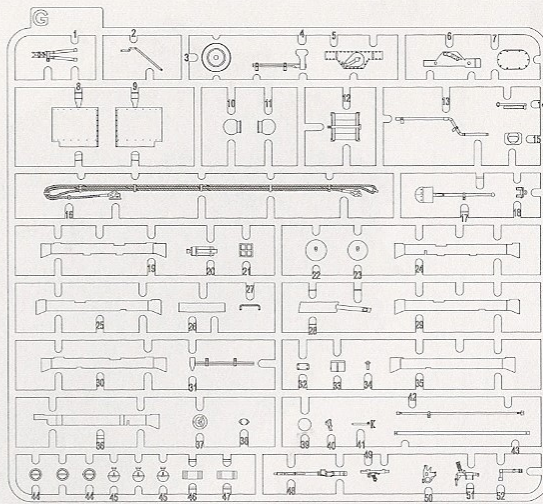
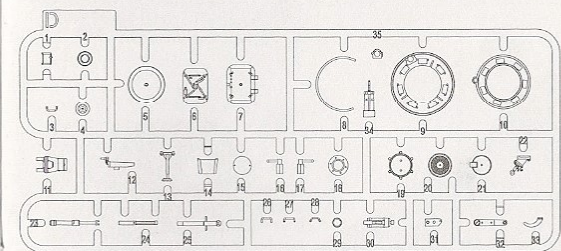
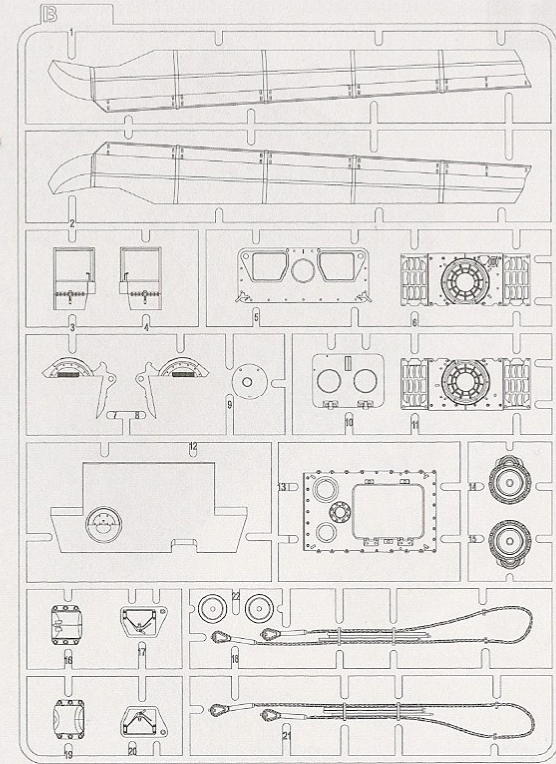
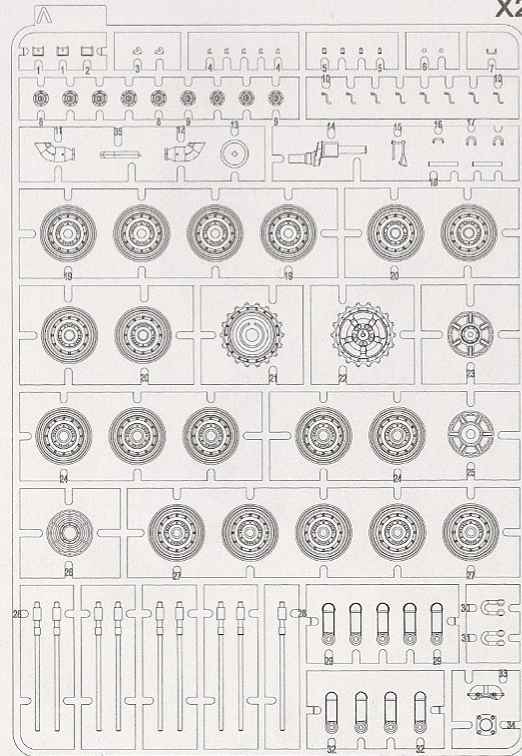
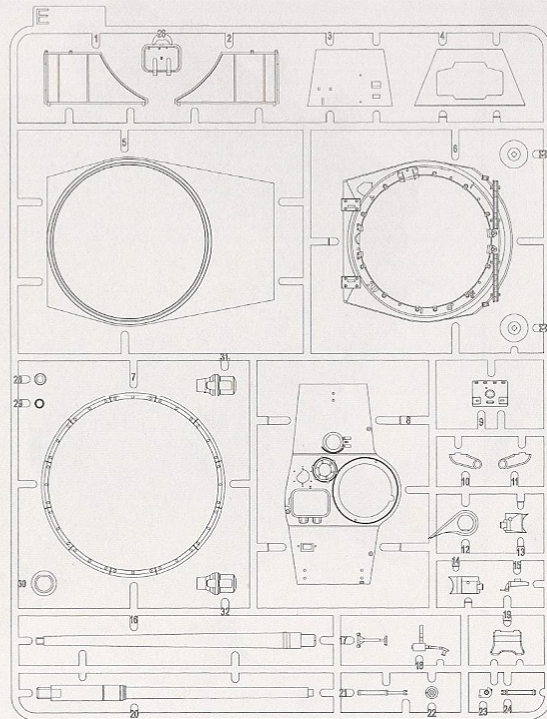
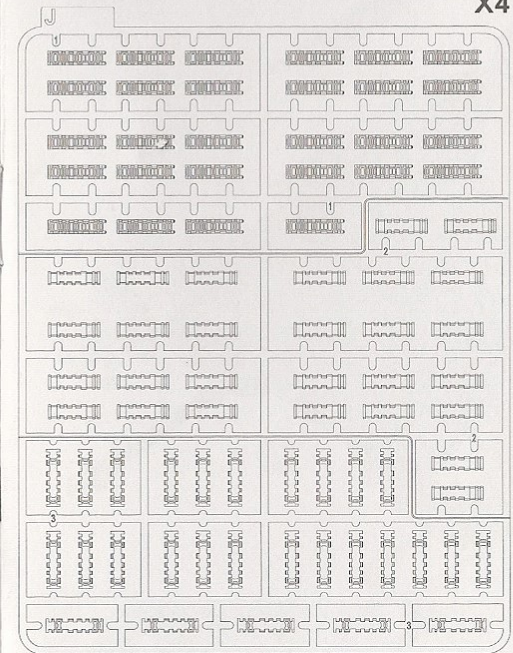

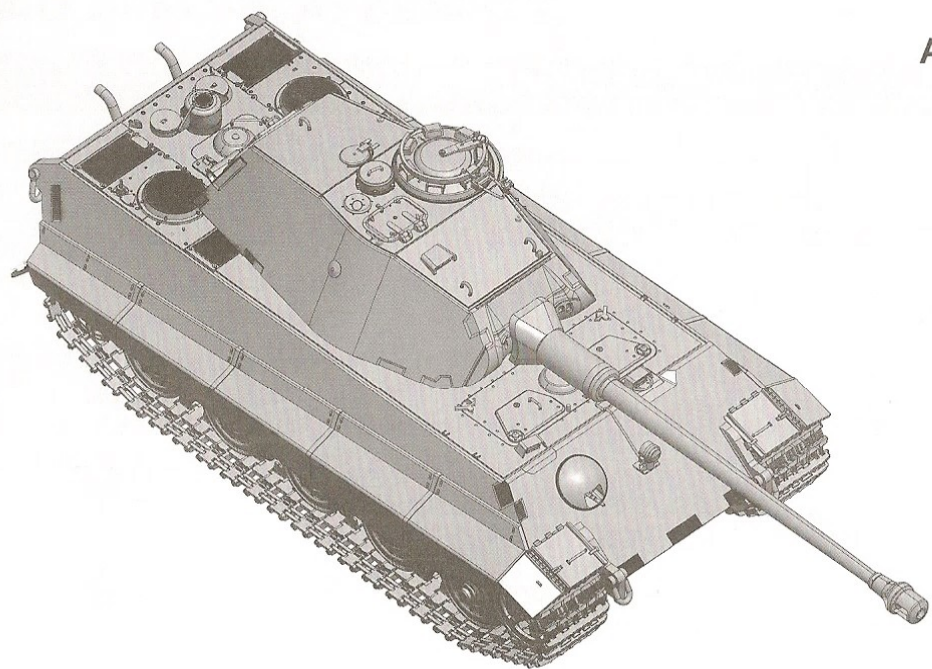

A

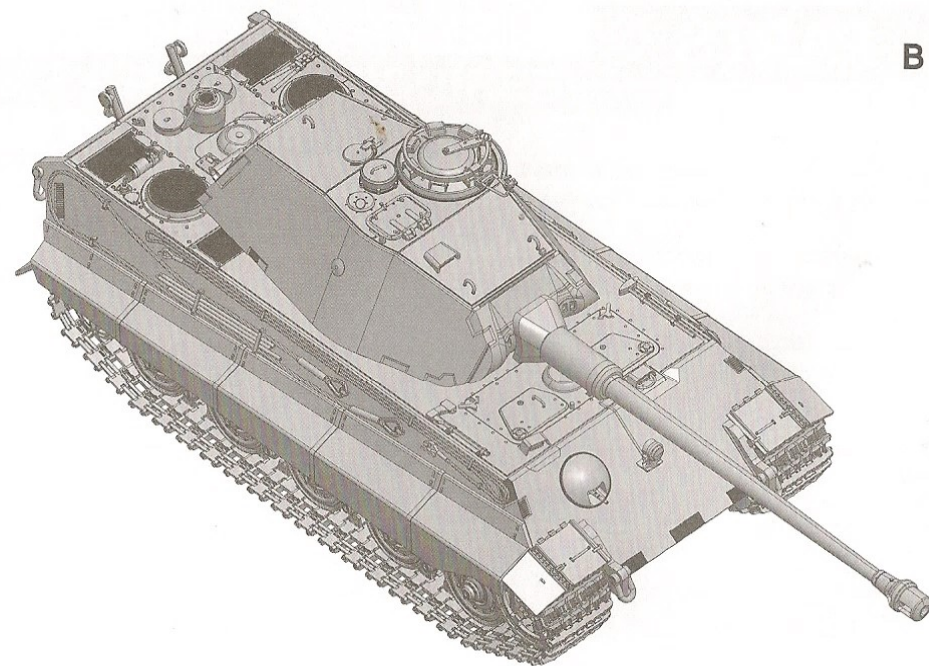

B

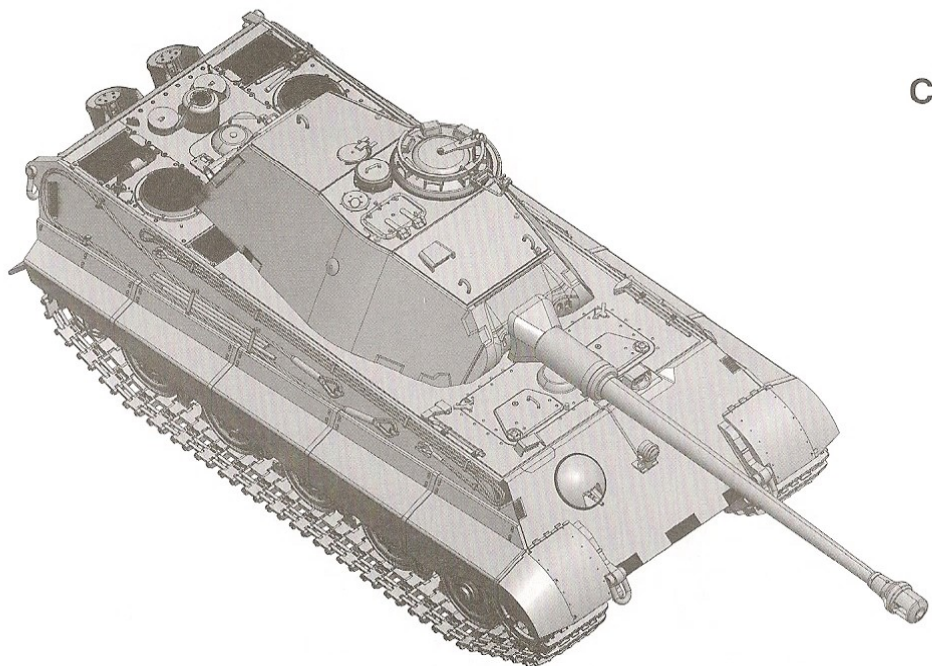

C

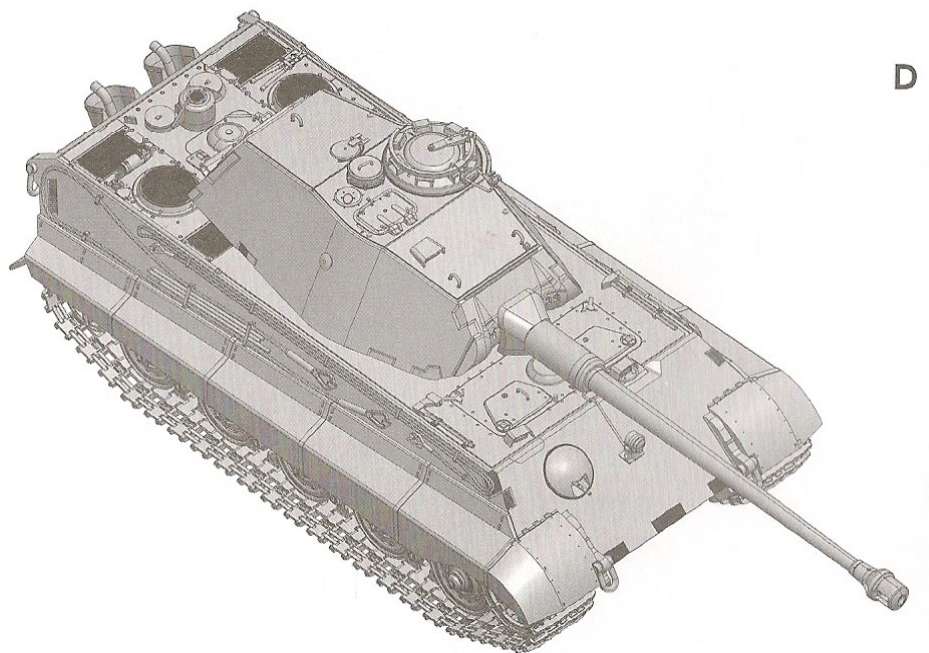

D

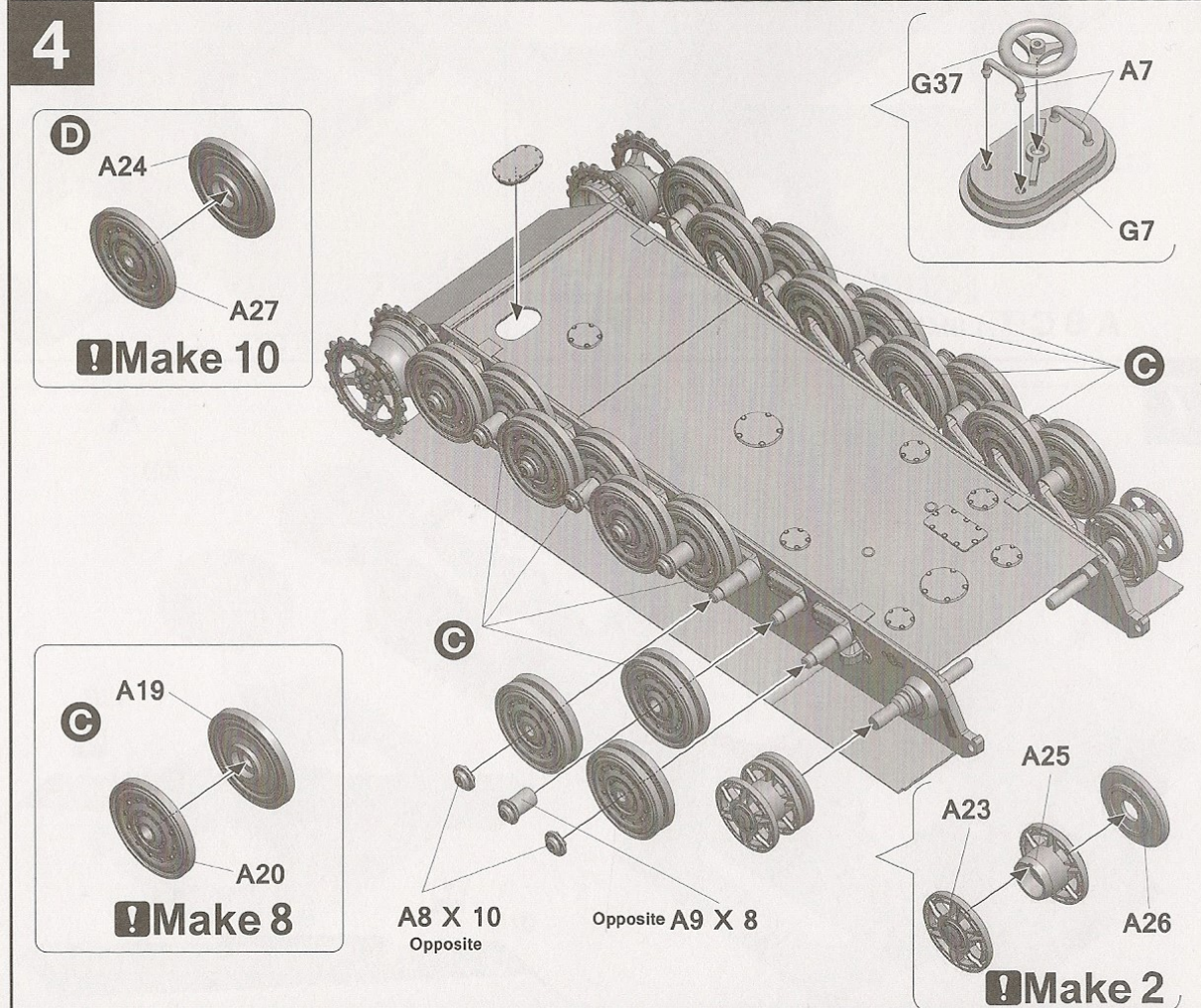
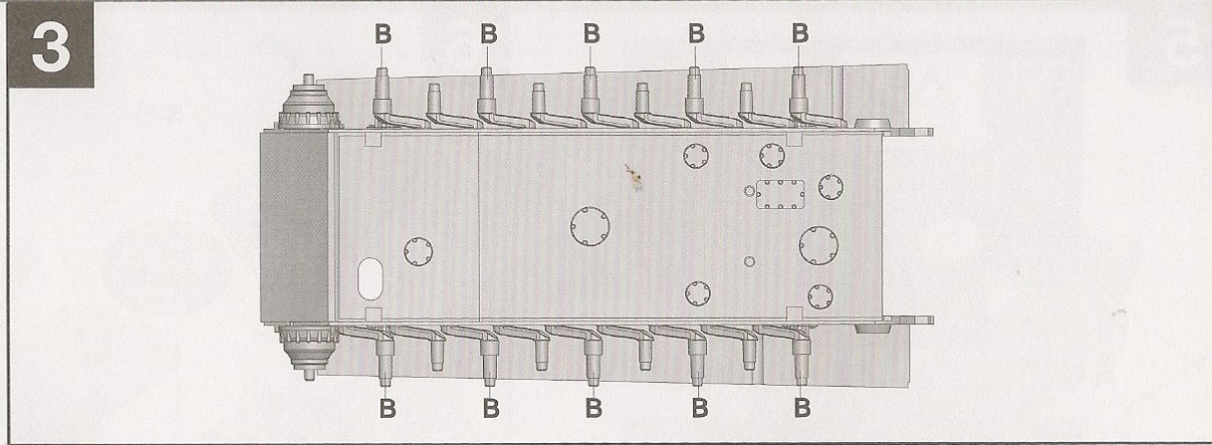
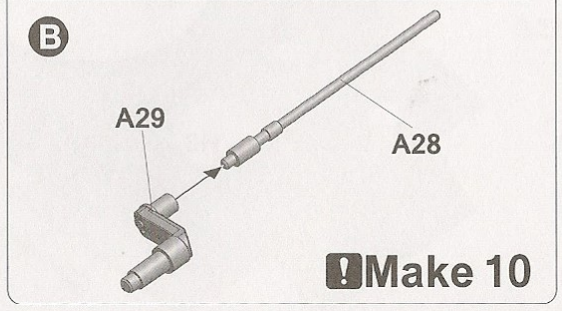
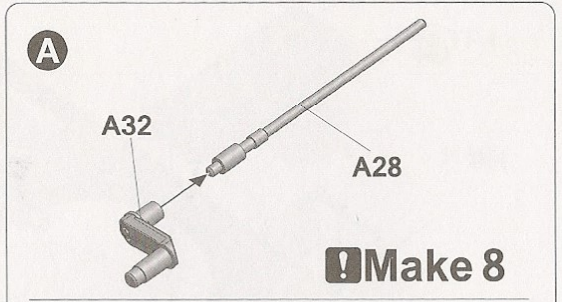
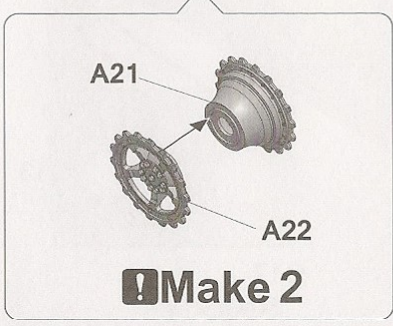
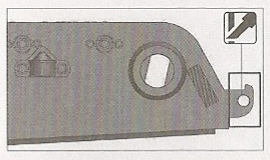
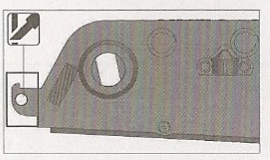
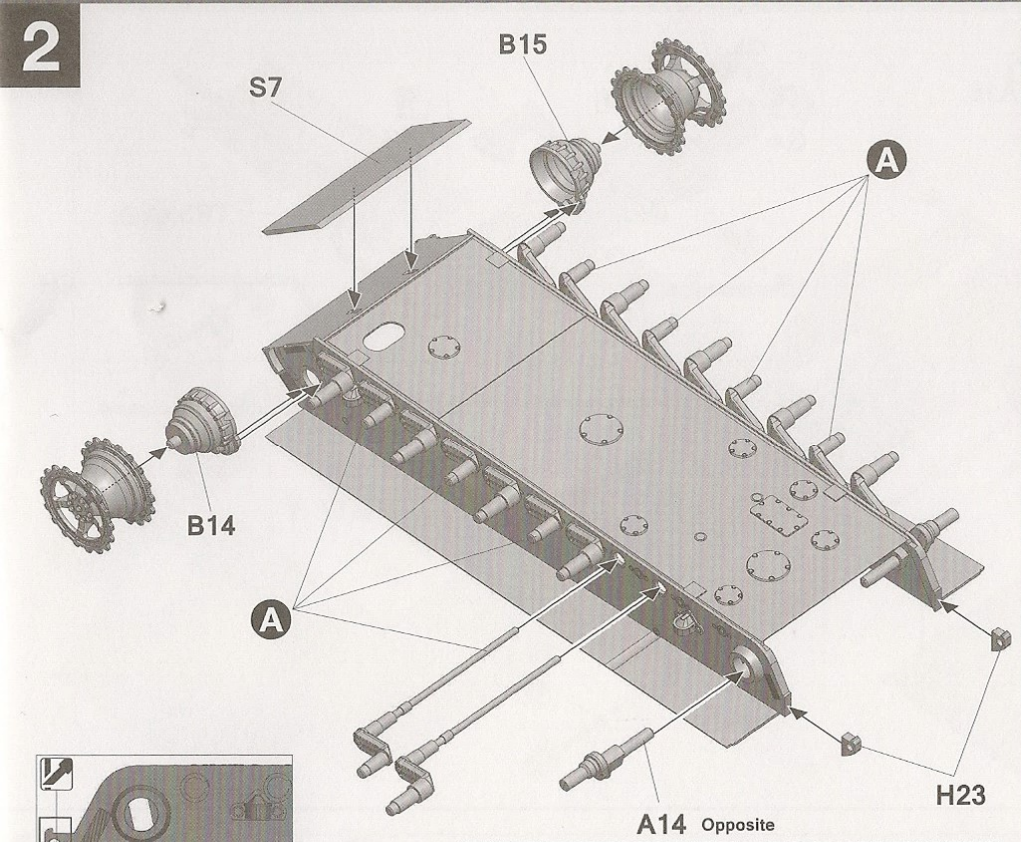

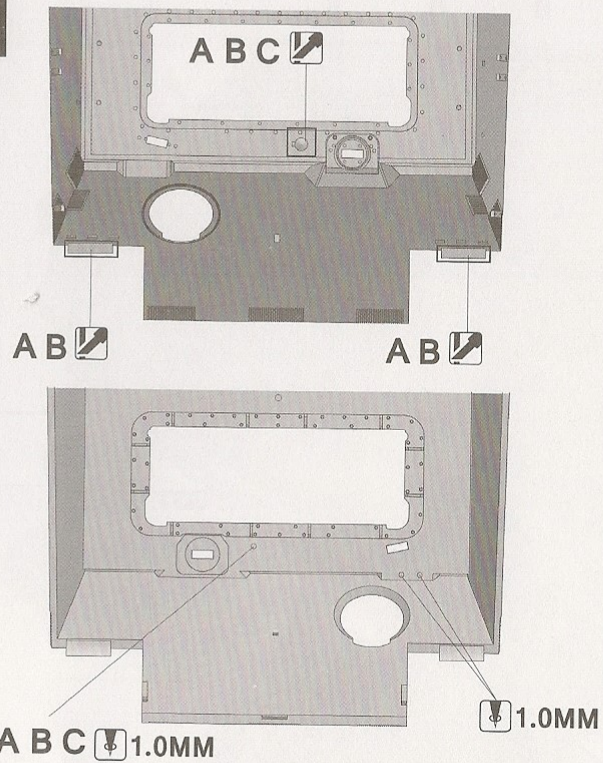
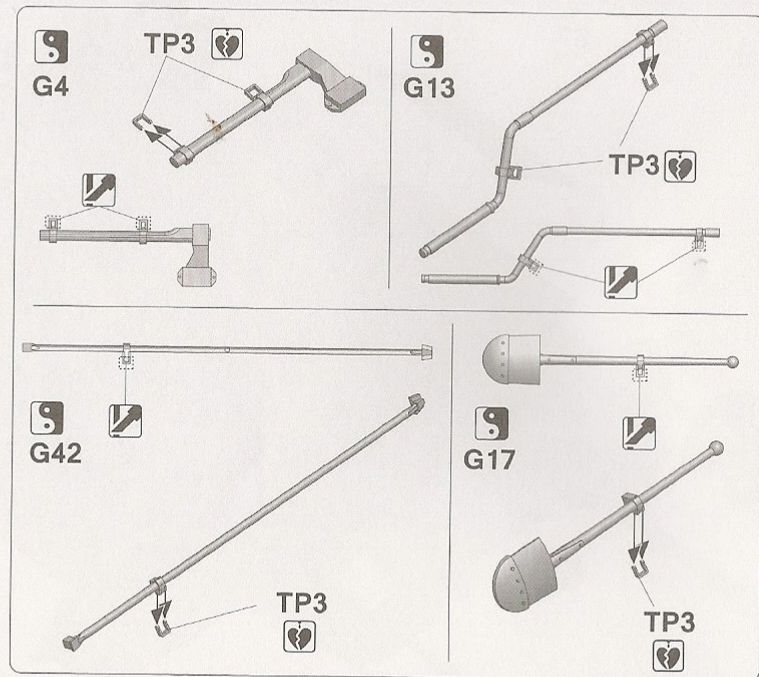
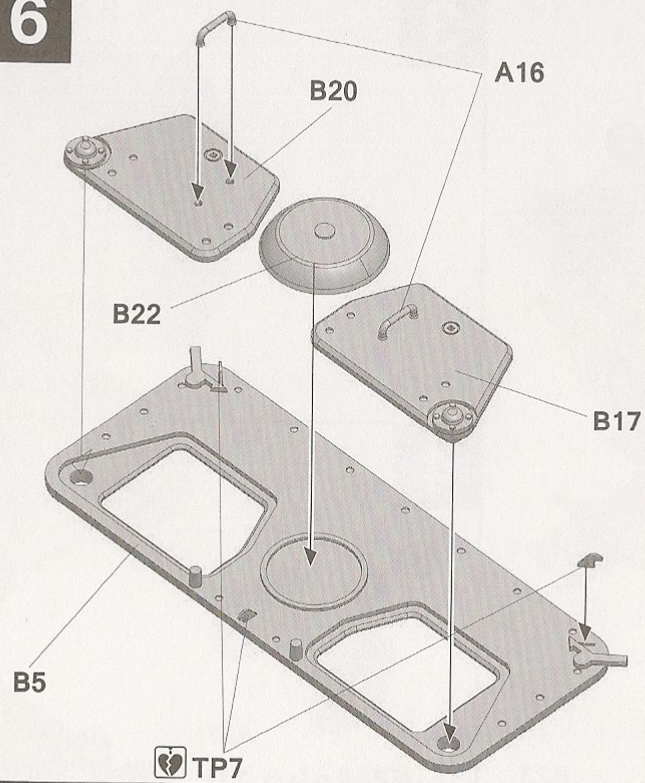
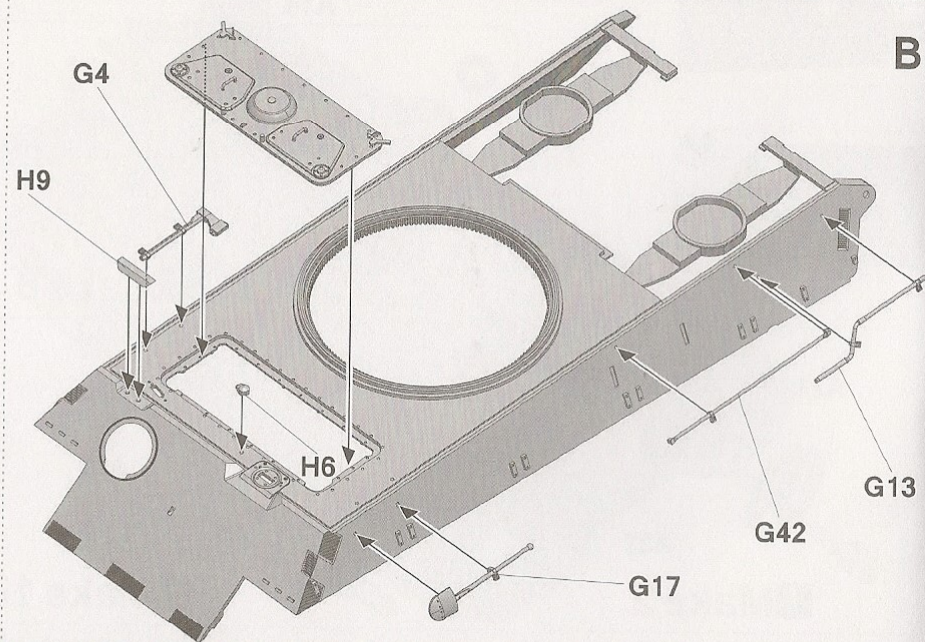
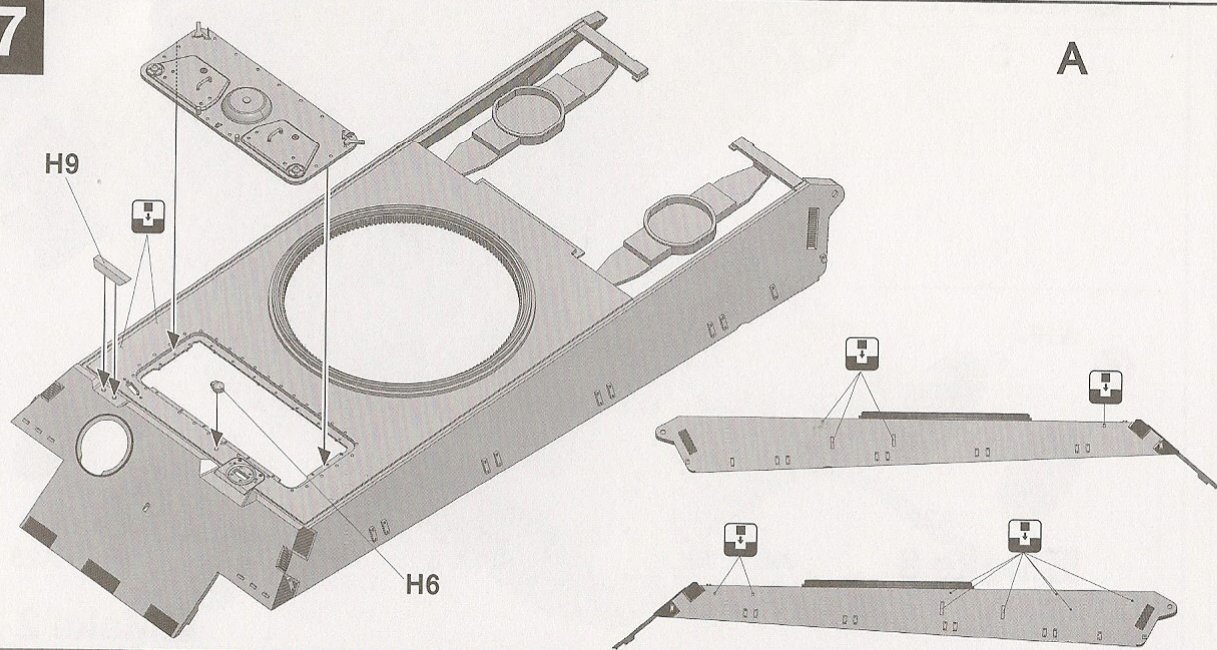
5**6****7****5**

8

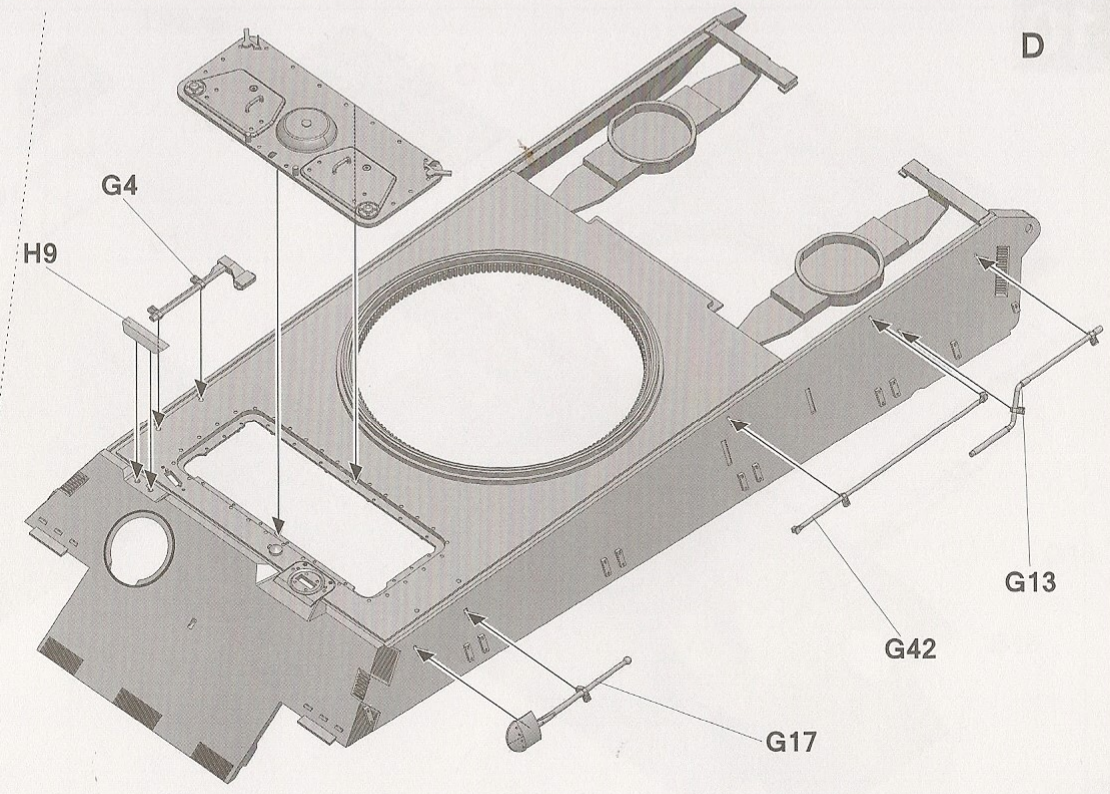
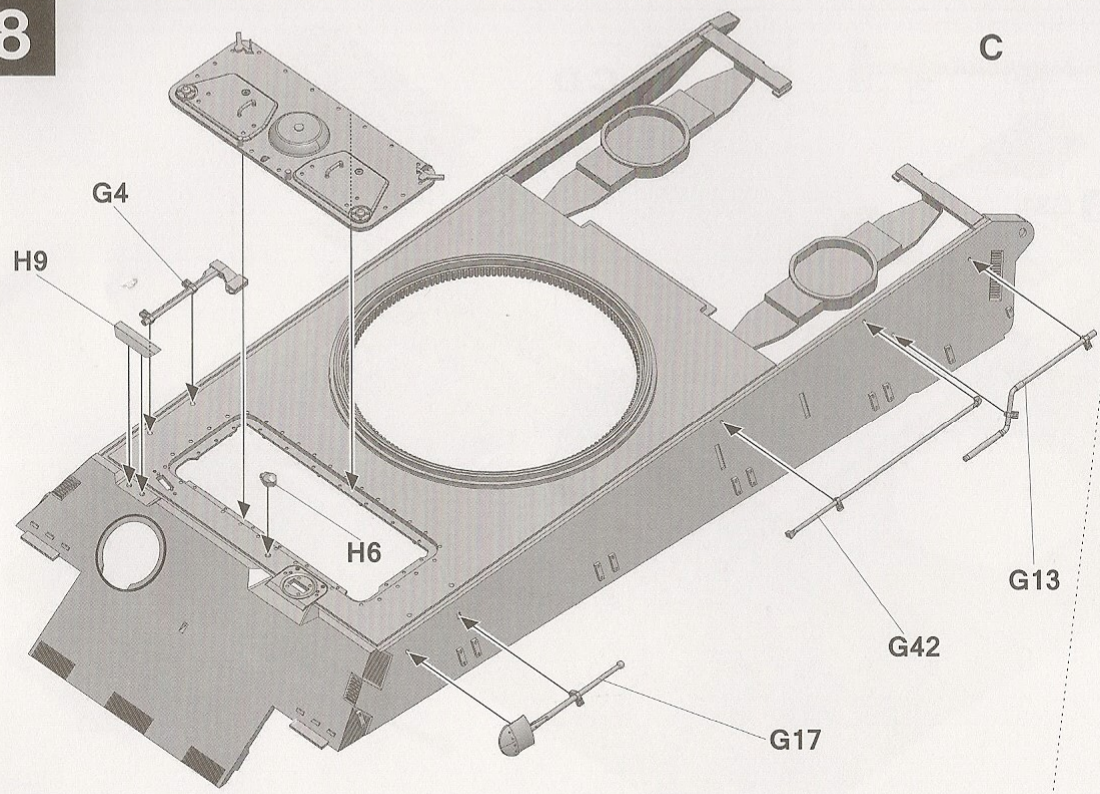

9

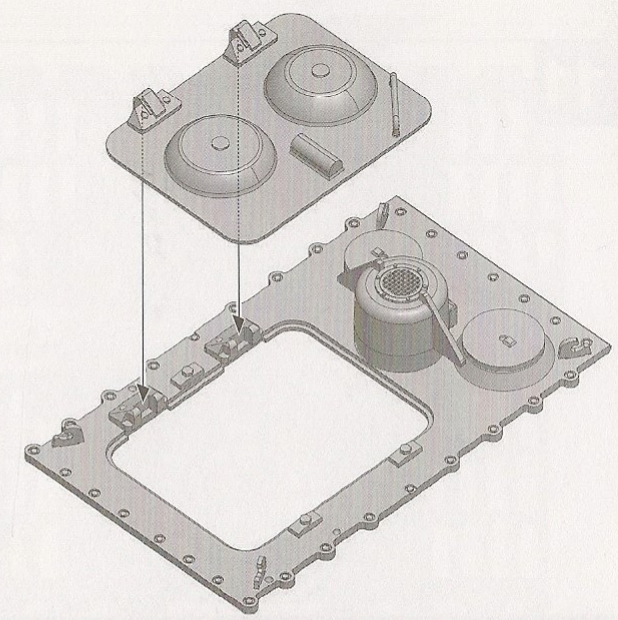
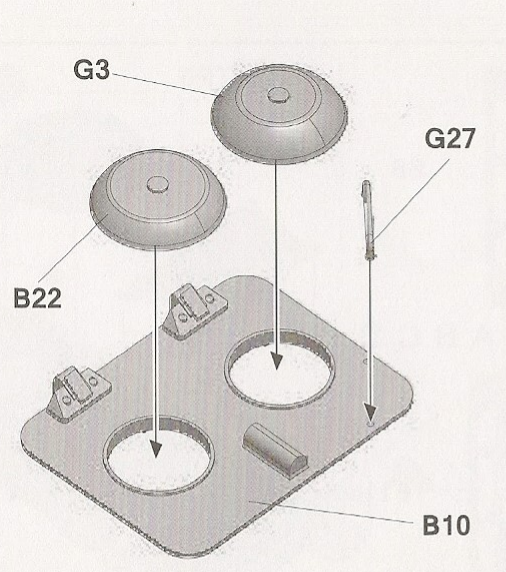
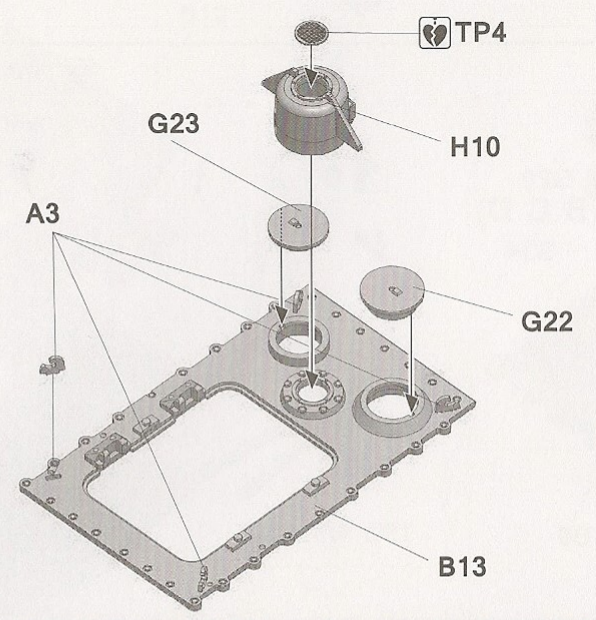
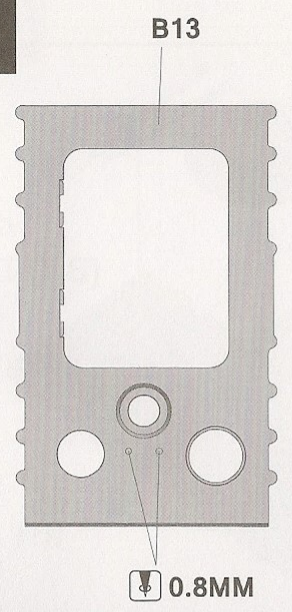

6

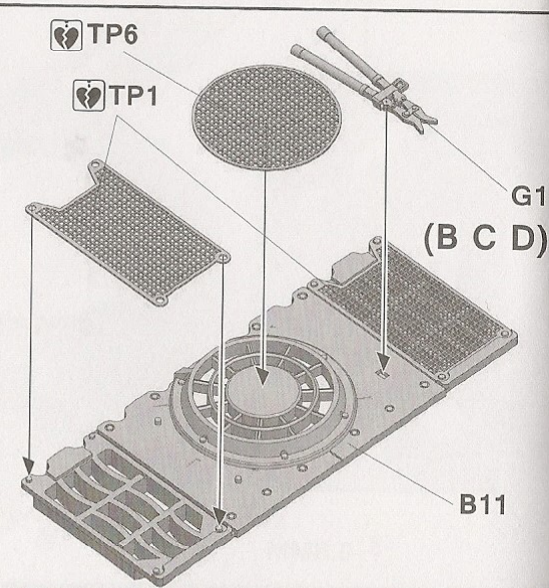
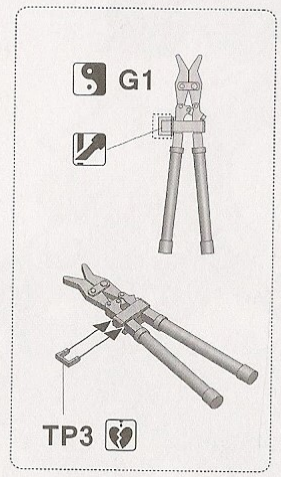
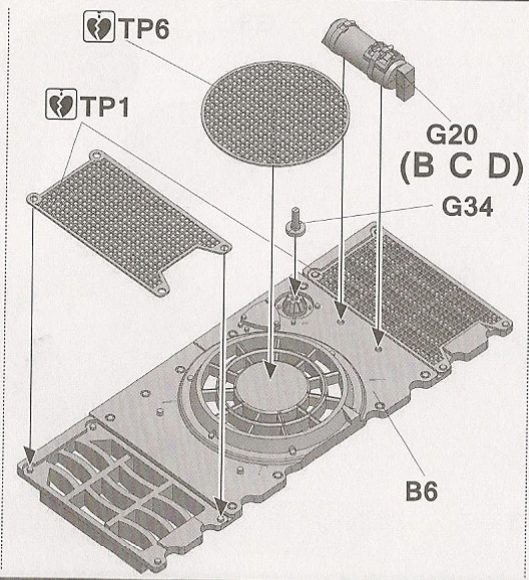
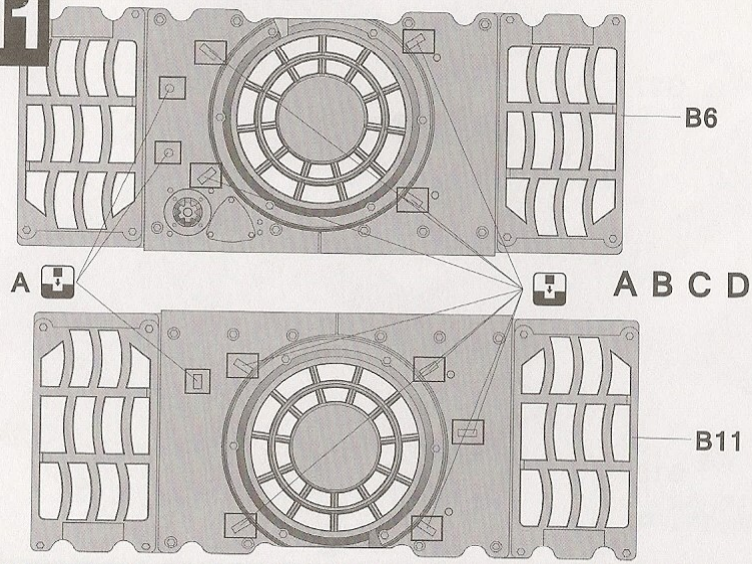
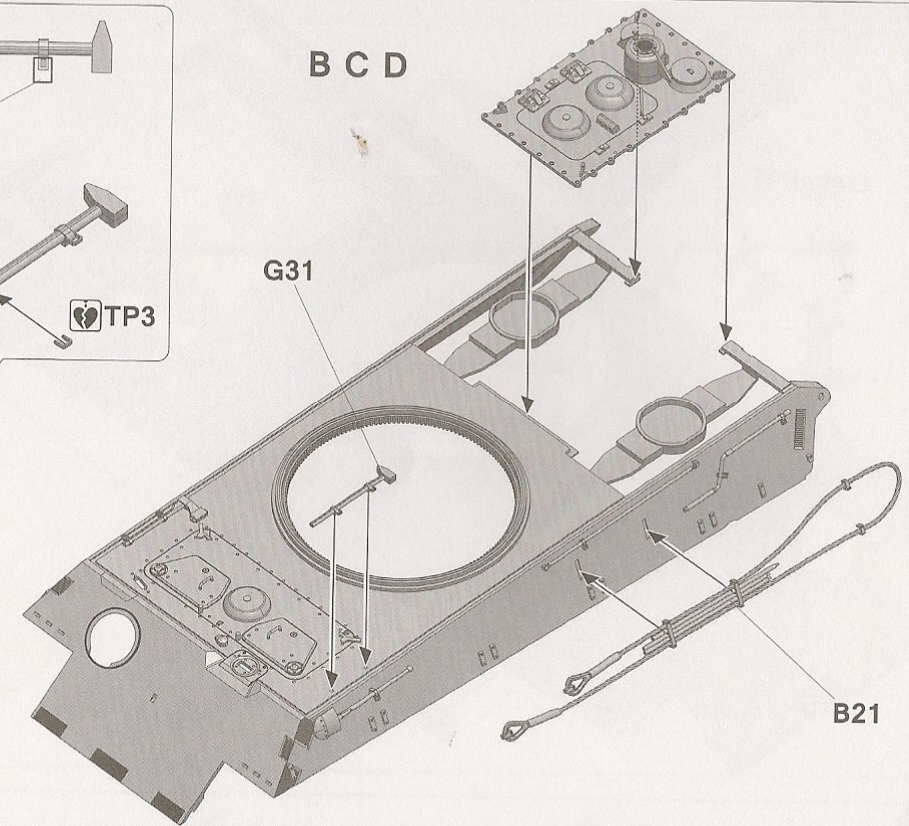
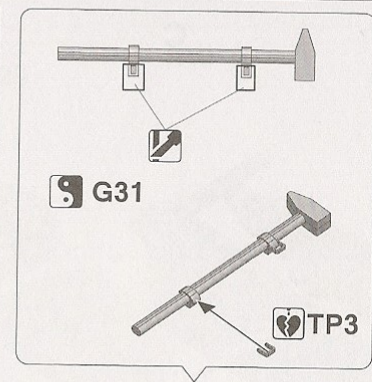
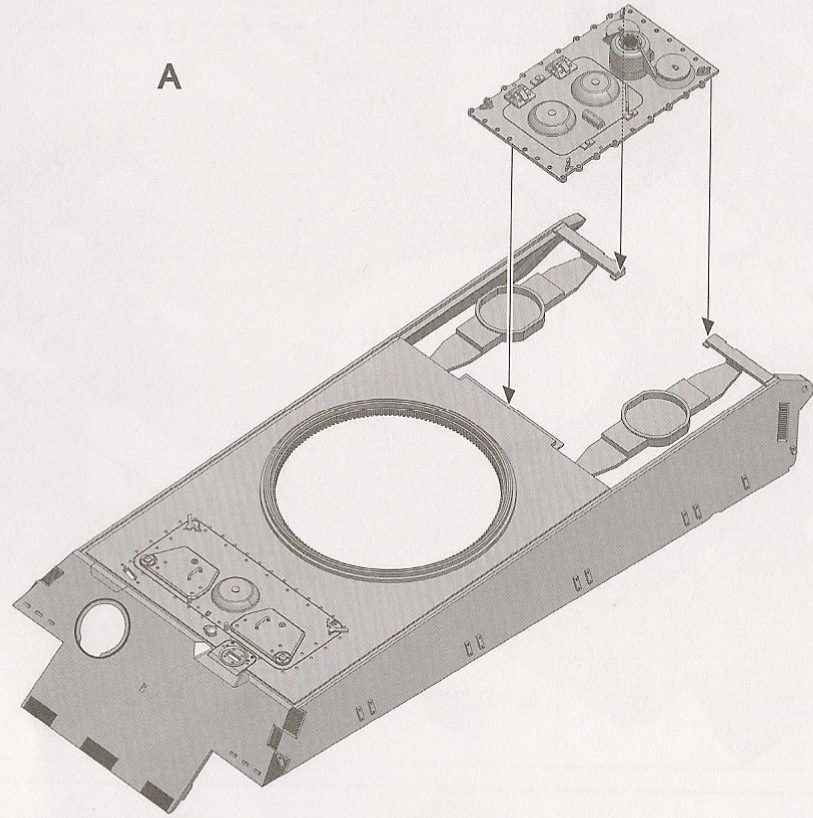

12

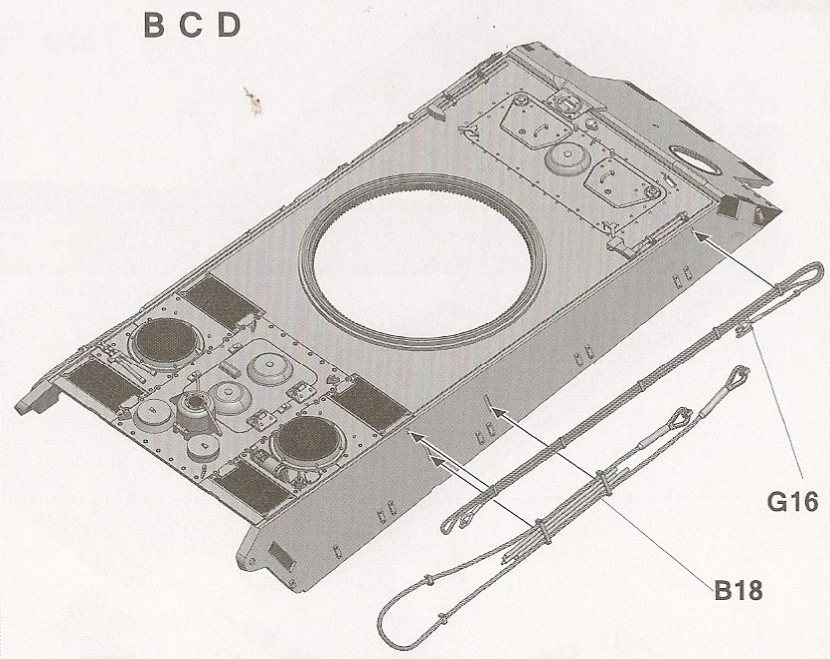
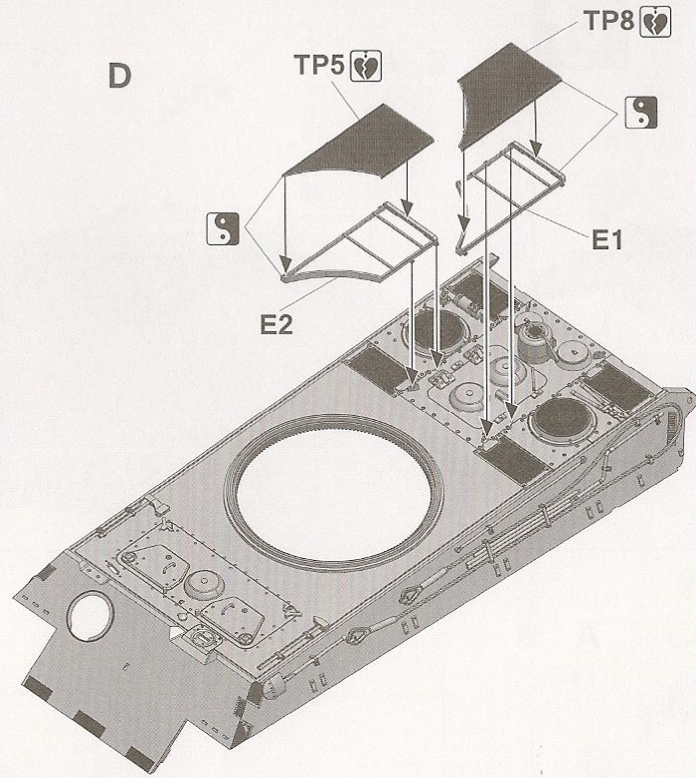
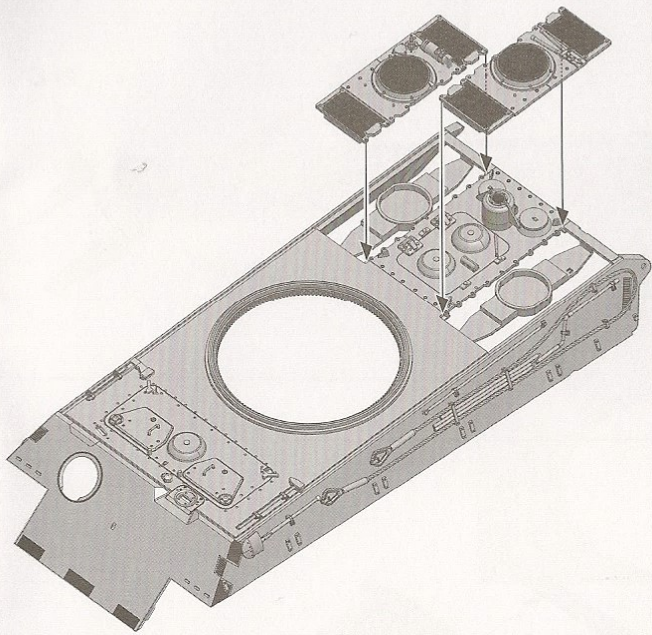

13

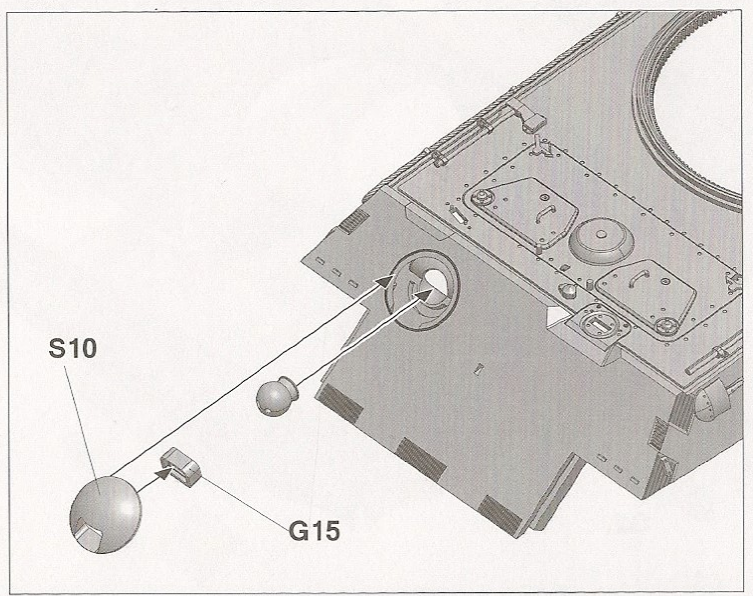
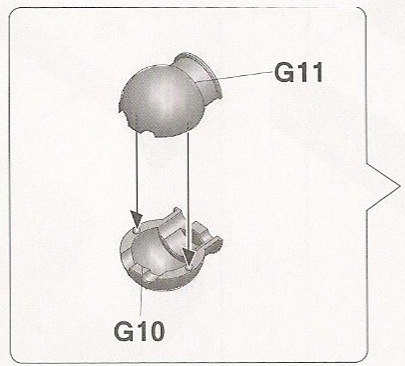
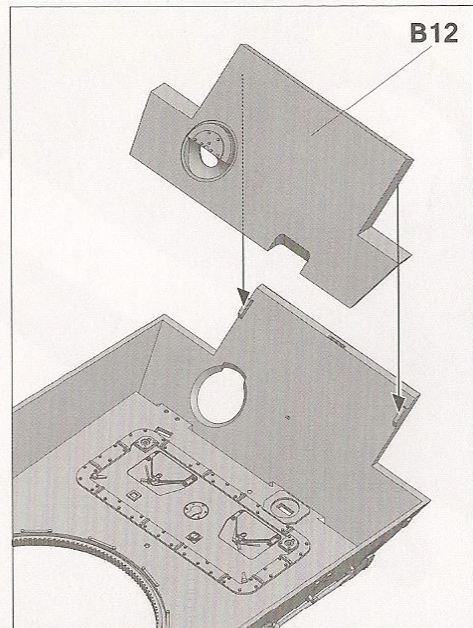

A B

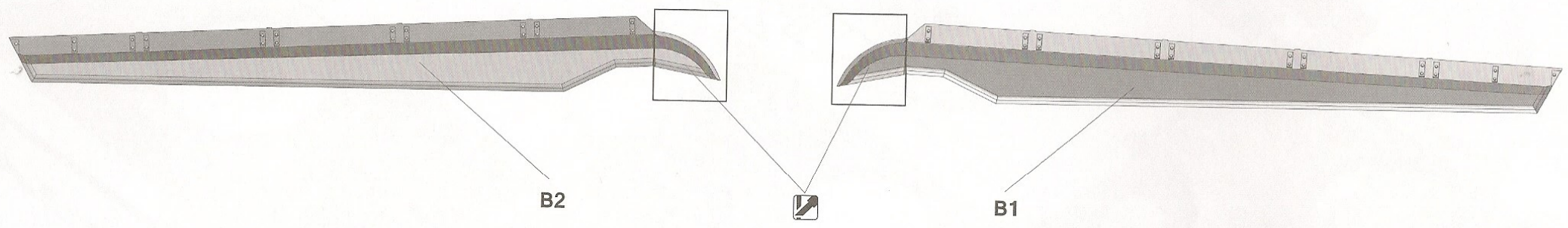

A B

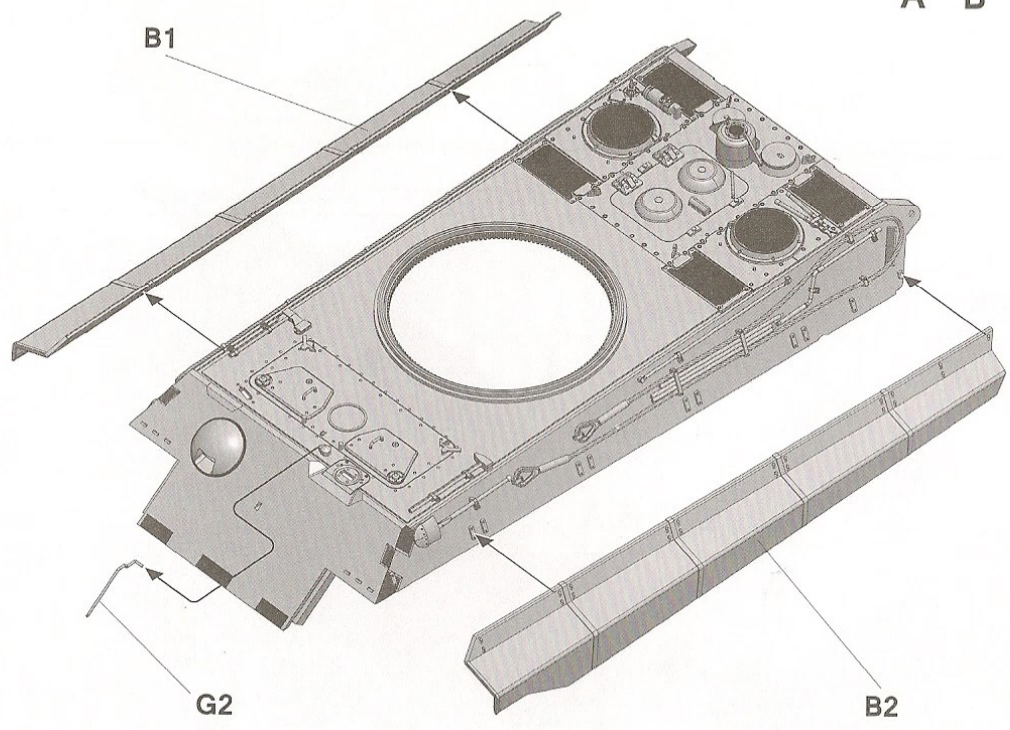

C D

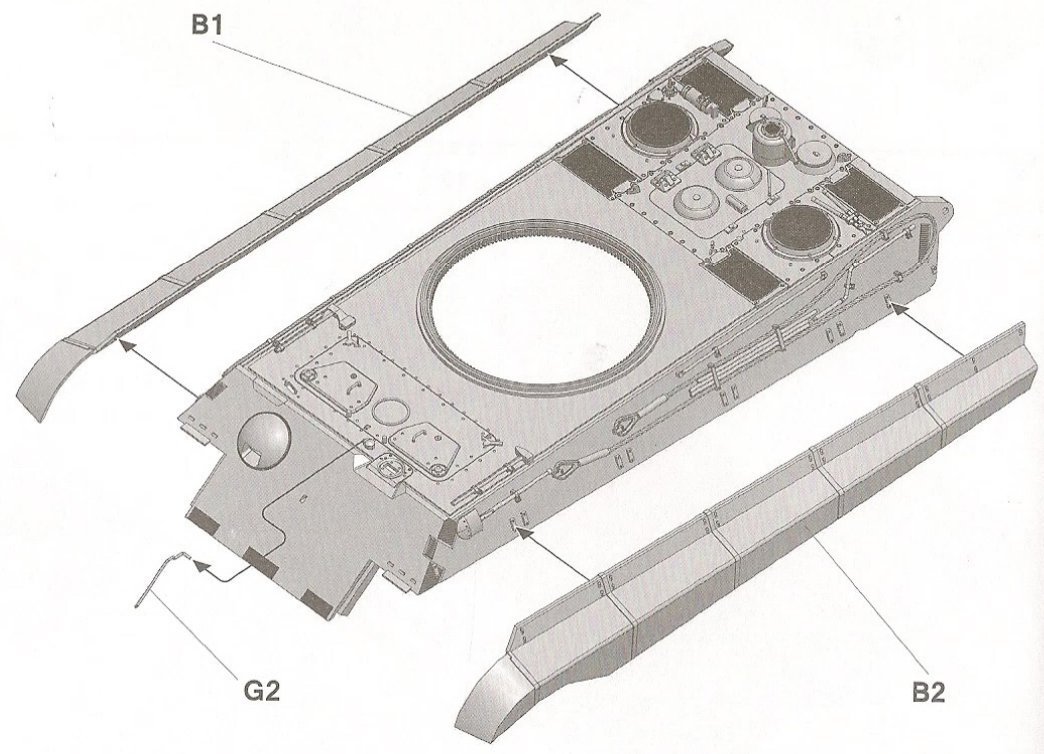

15

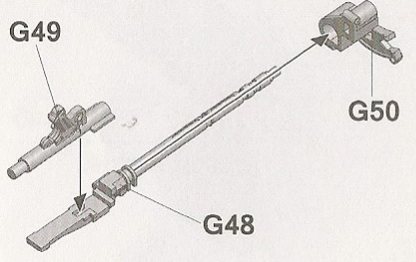

16

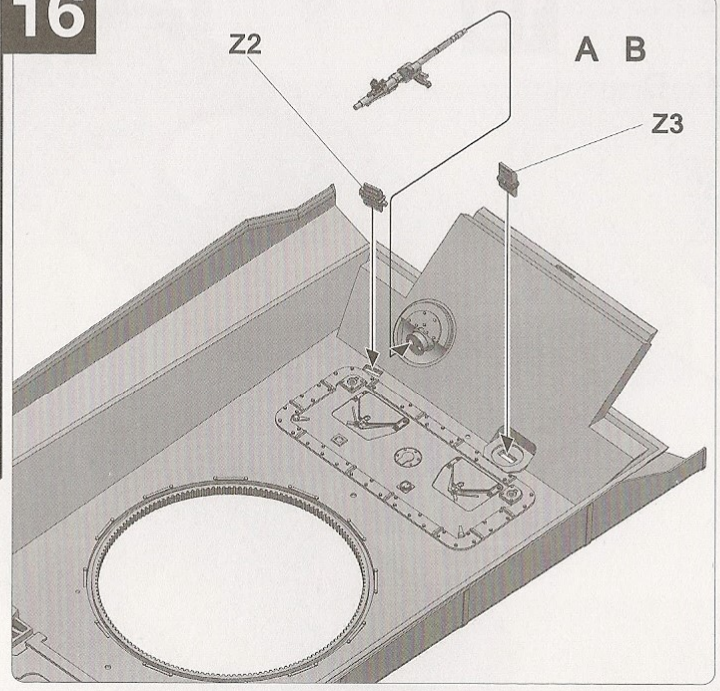

17

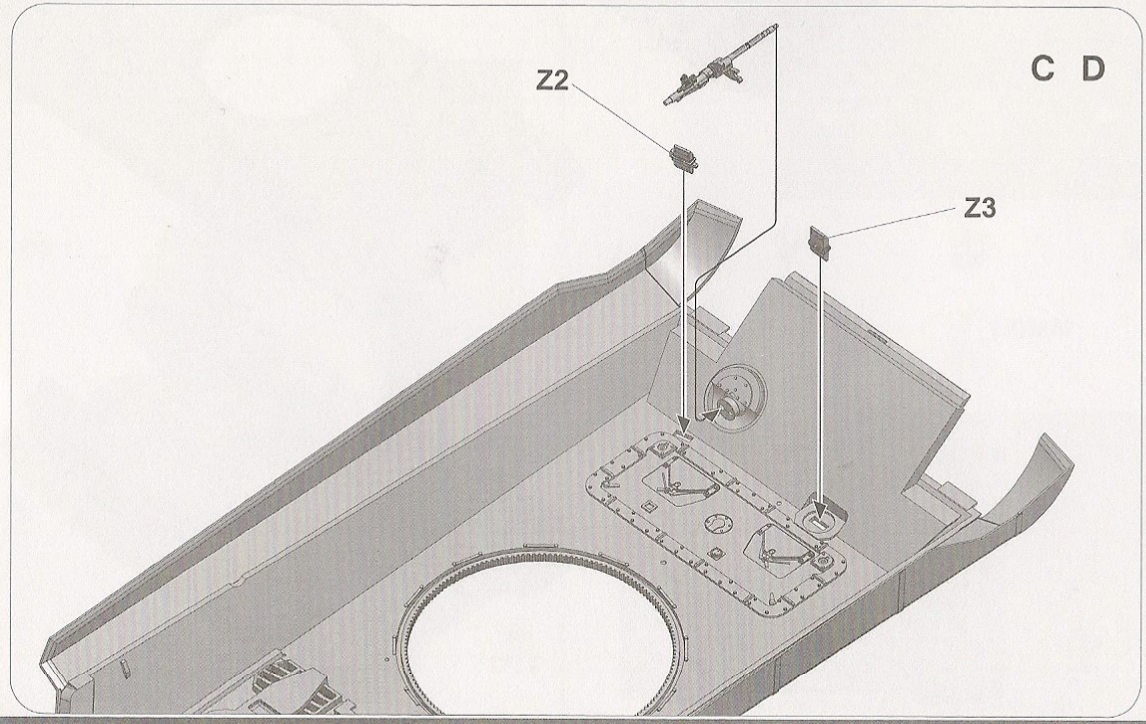
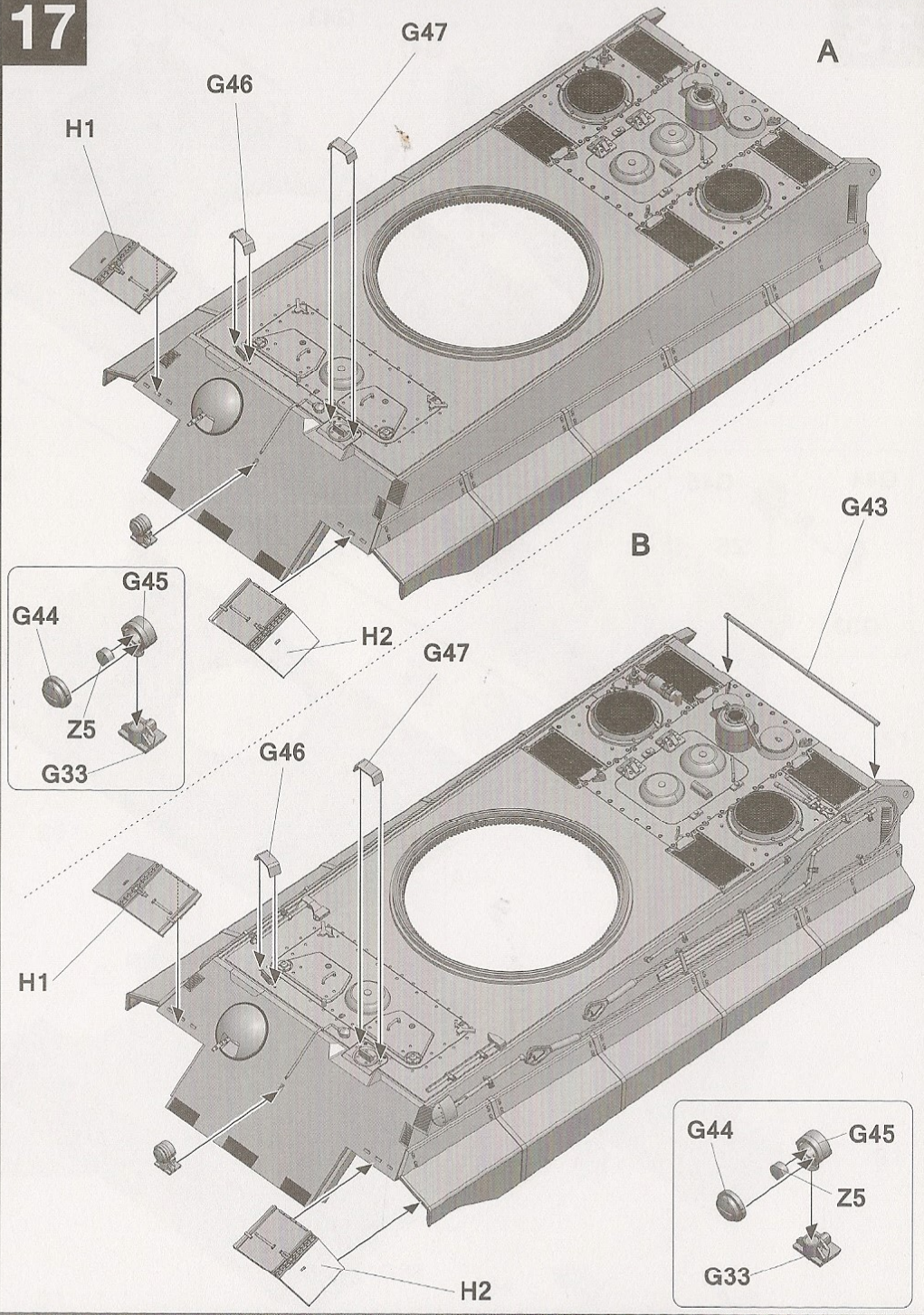

18

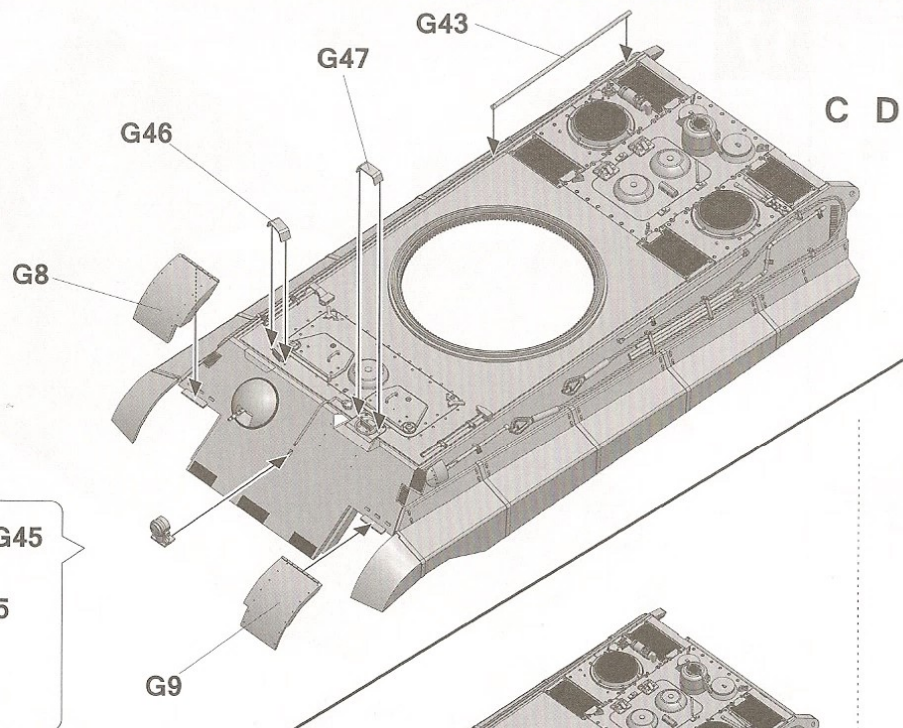

19

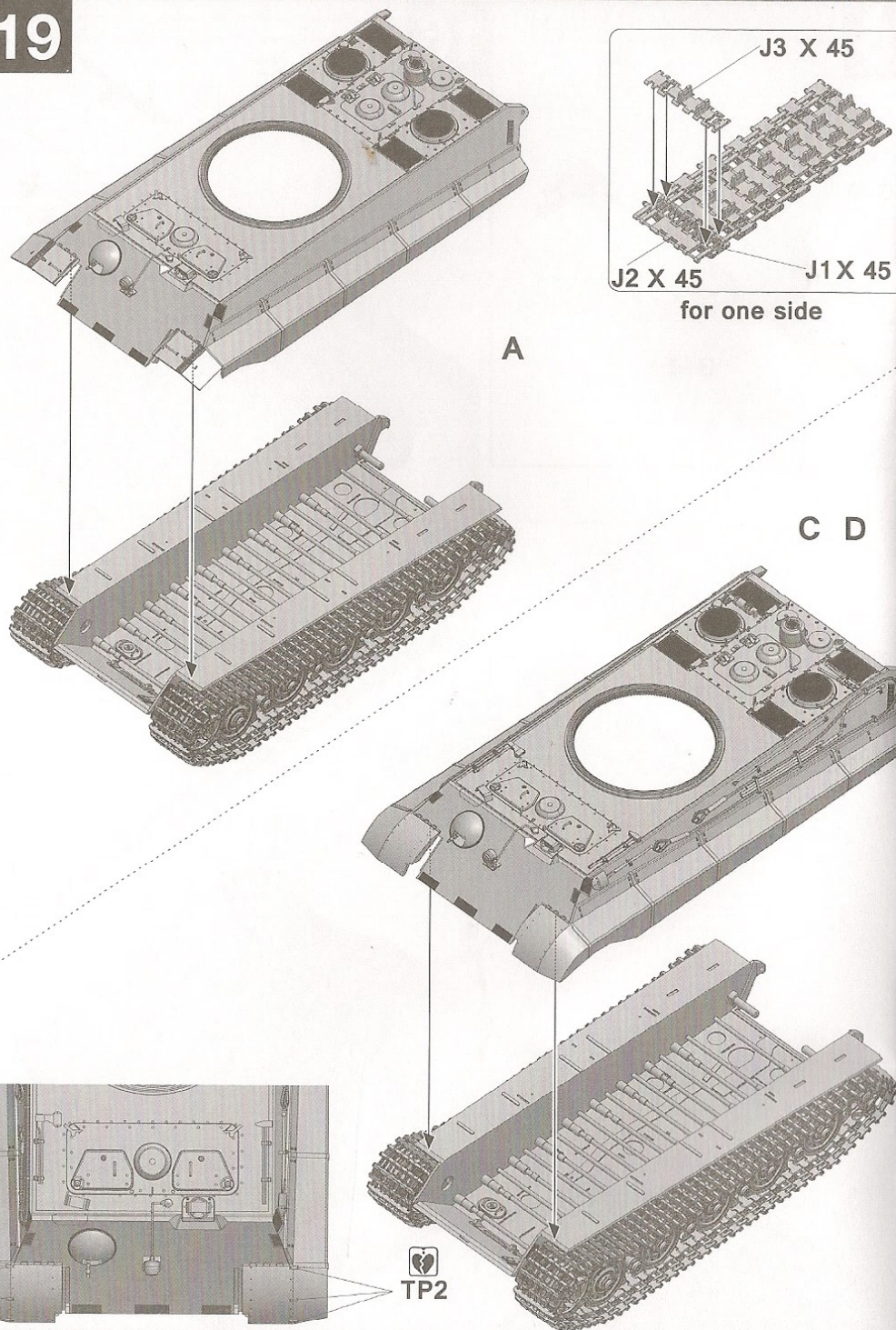

20

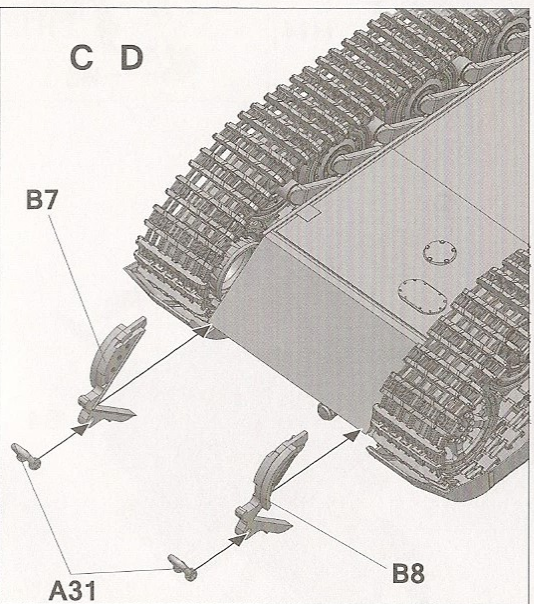
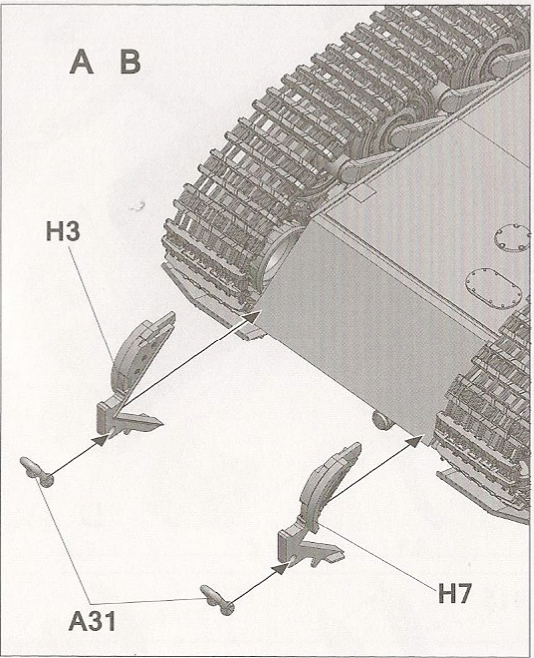

21

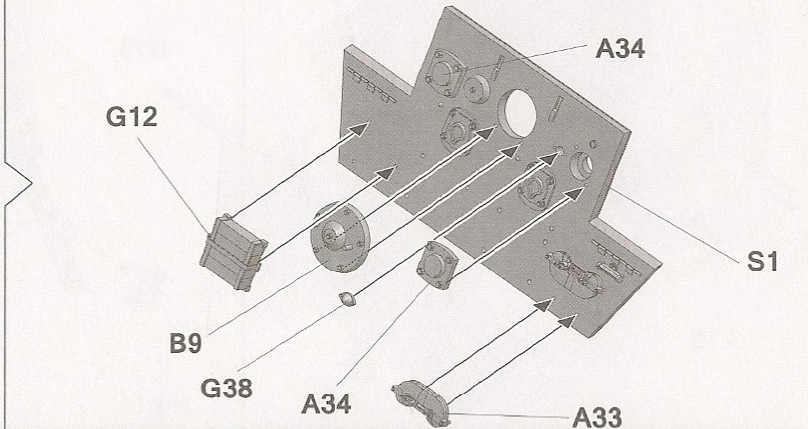
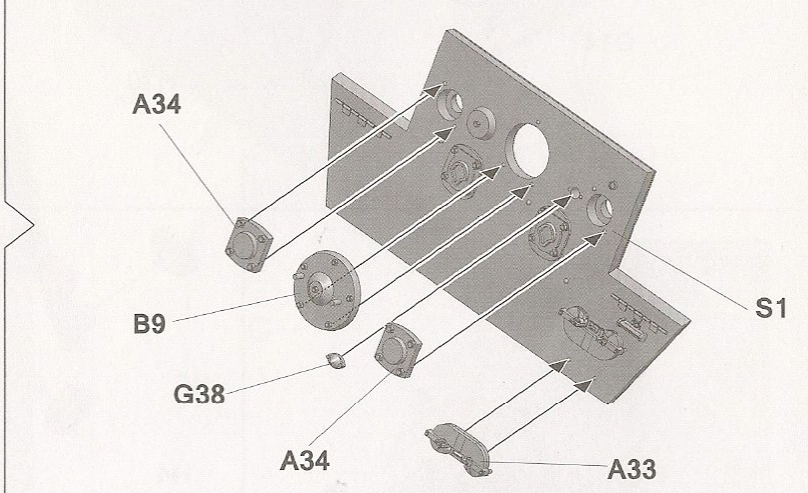
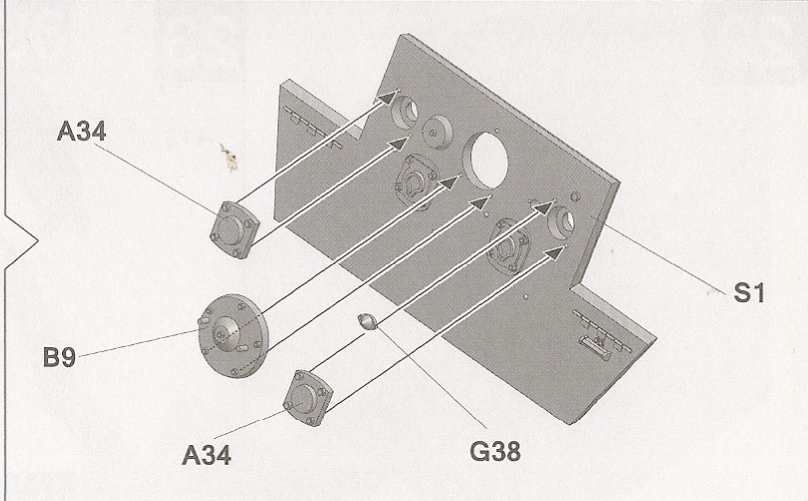
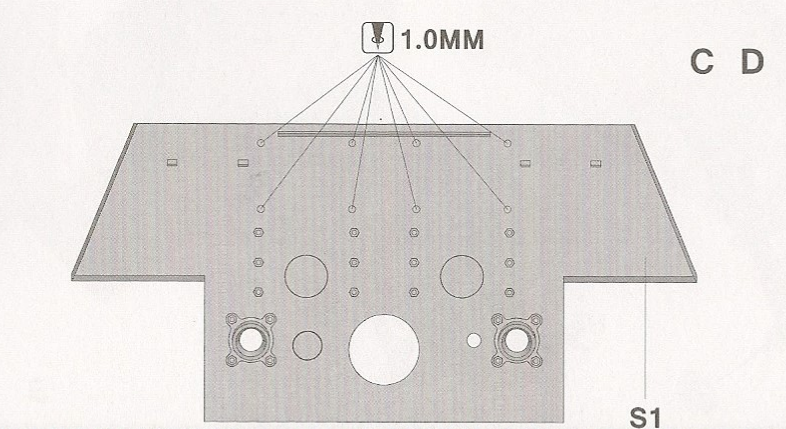
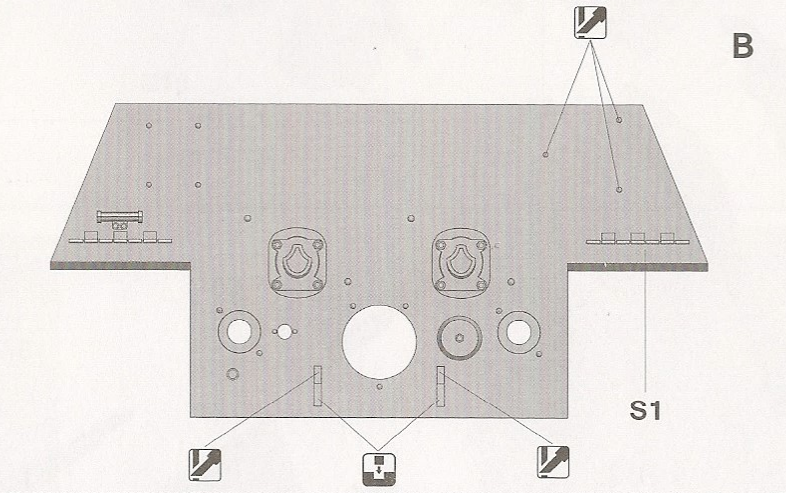
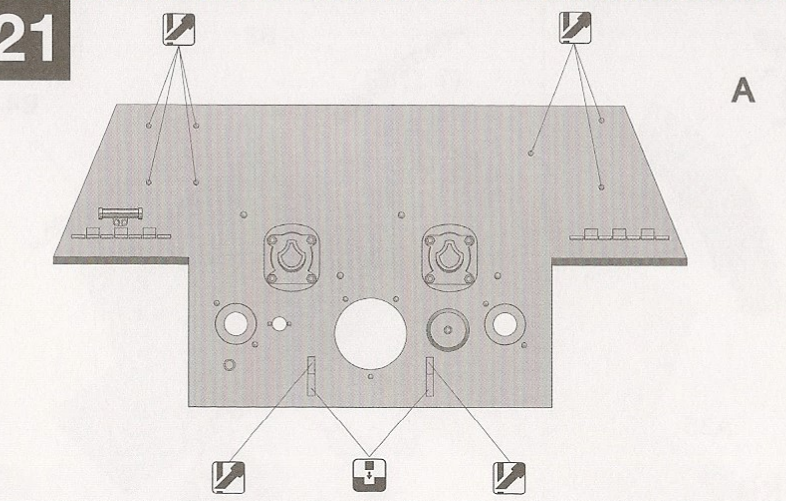

22

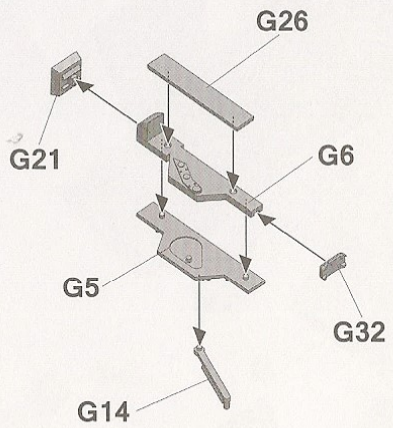

C D

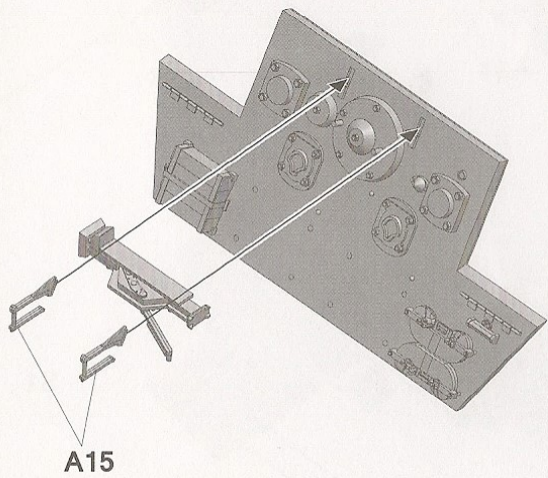

23

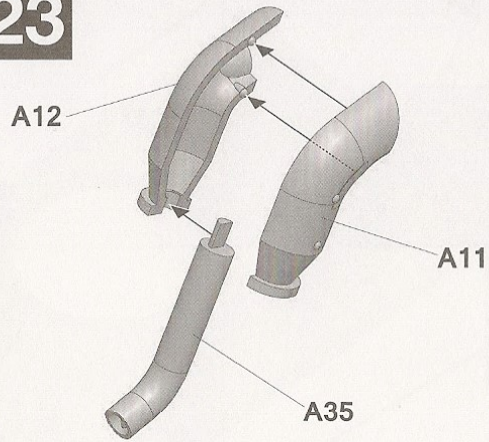

Make 2

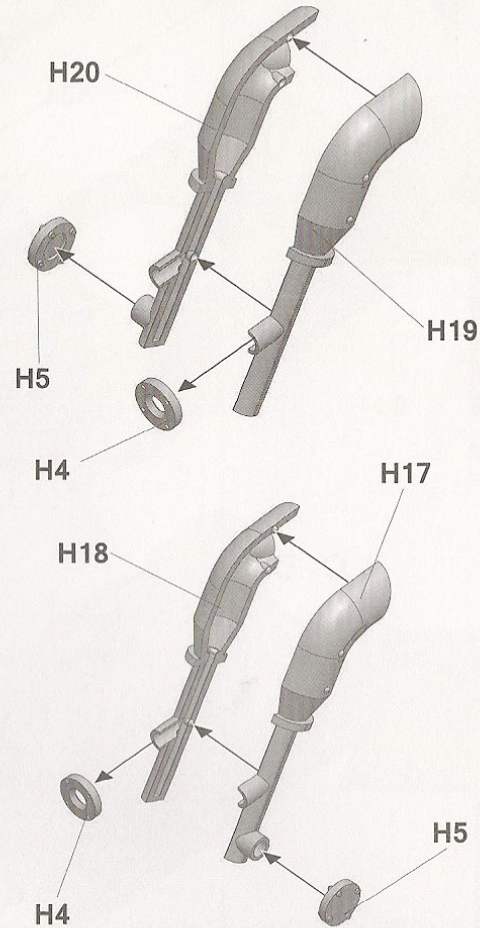

13

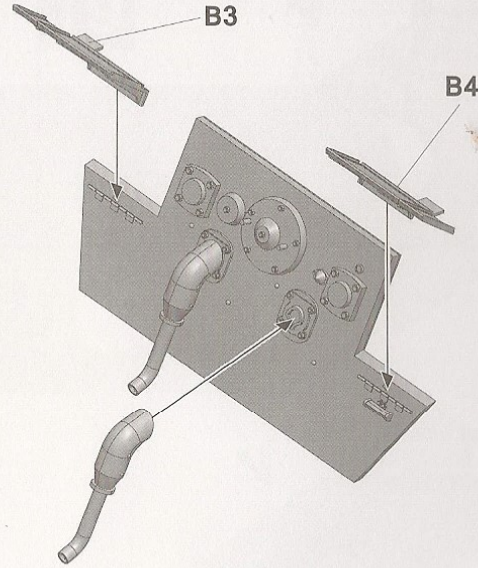

A

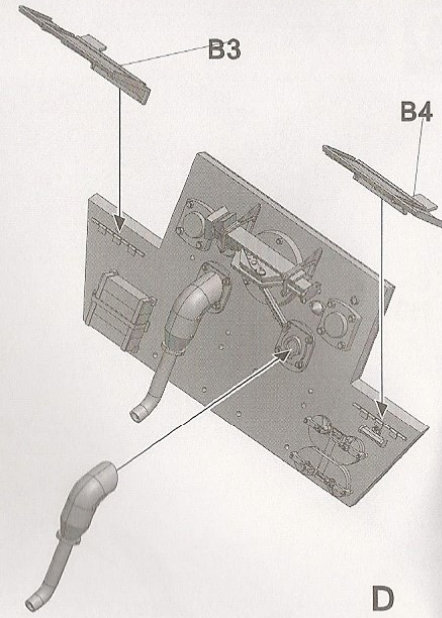

D

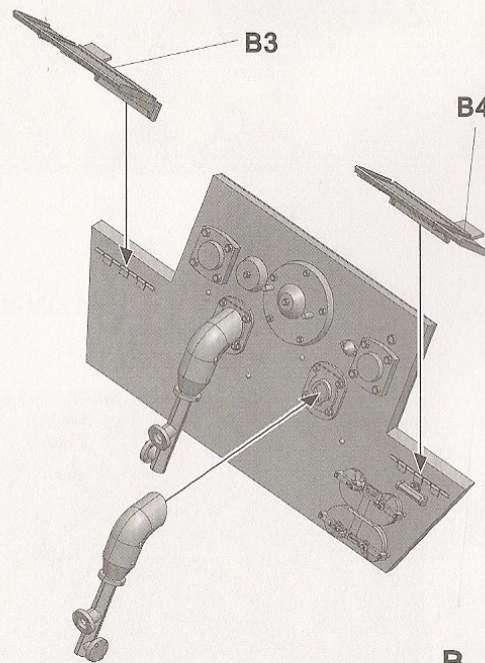

B

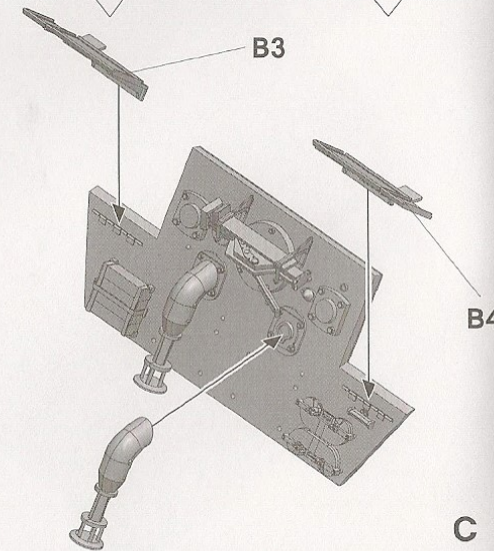
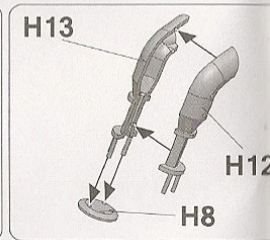
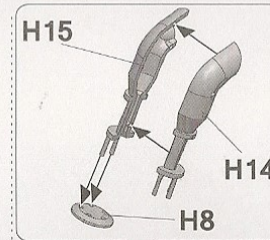

C

24

A

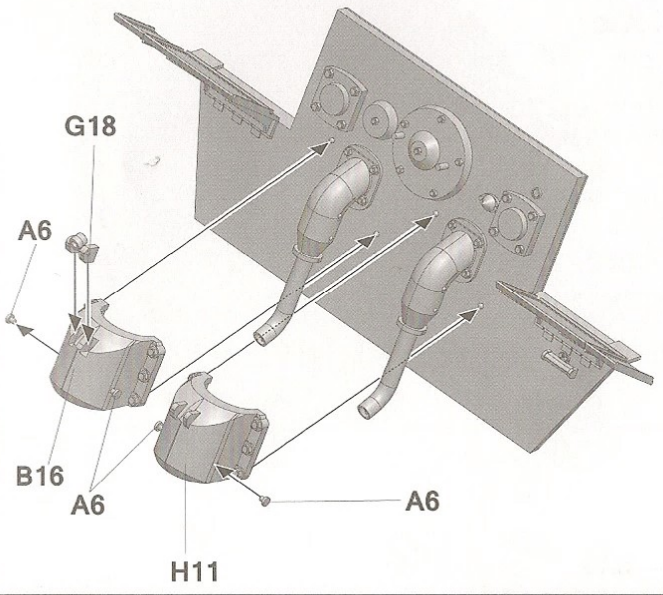

B C D

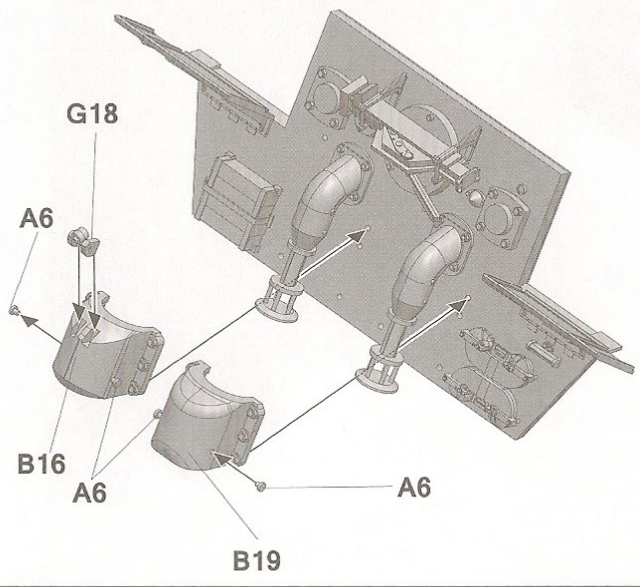

26

D

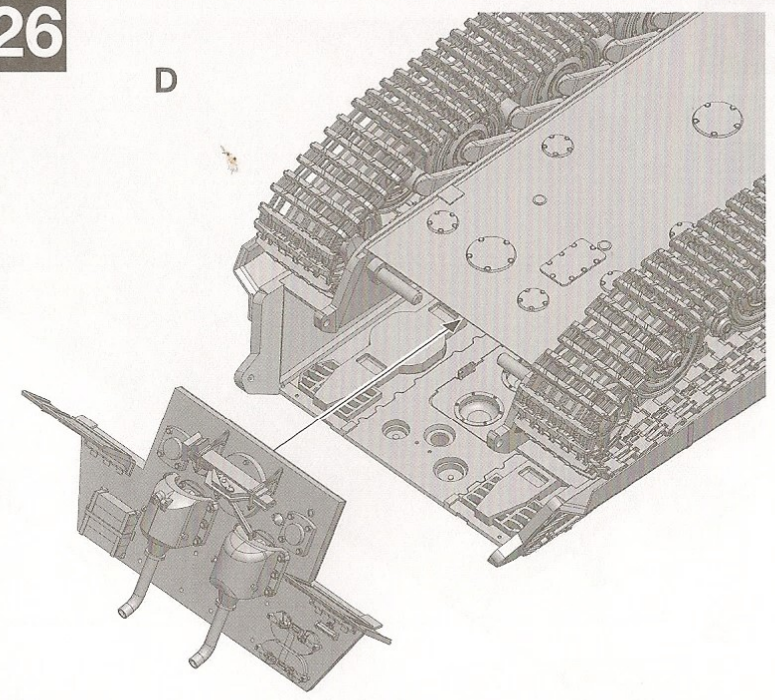

25

A

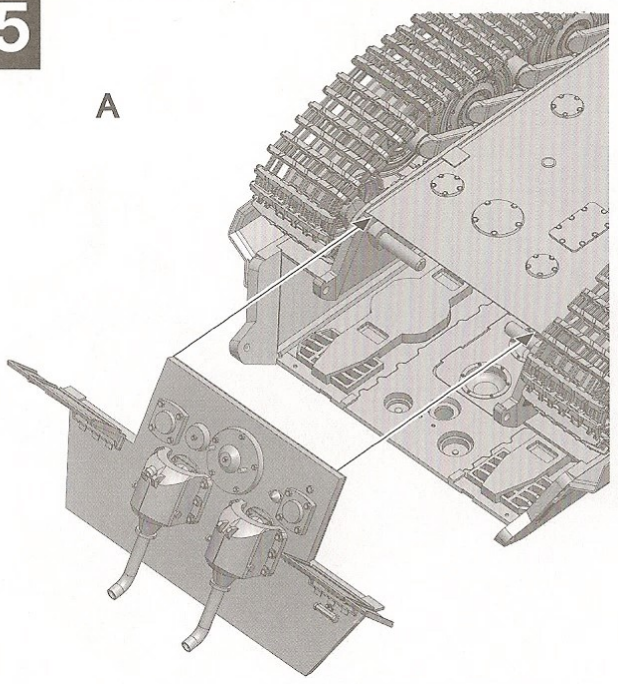

B

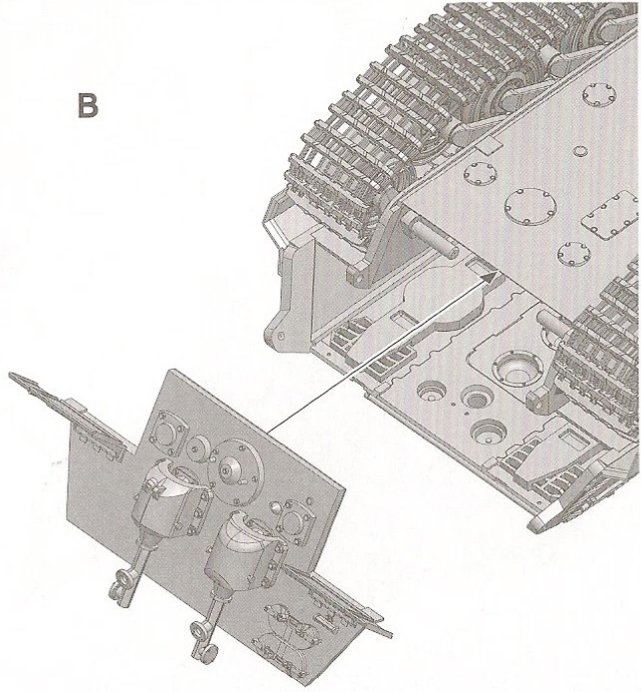

C

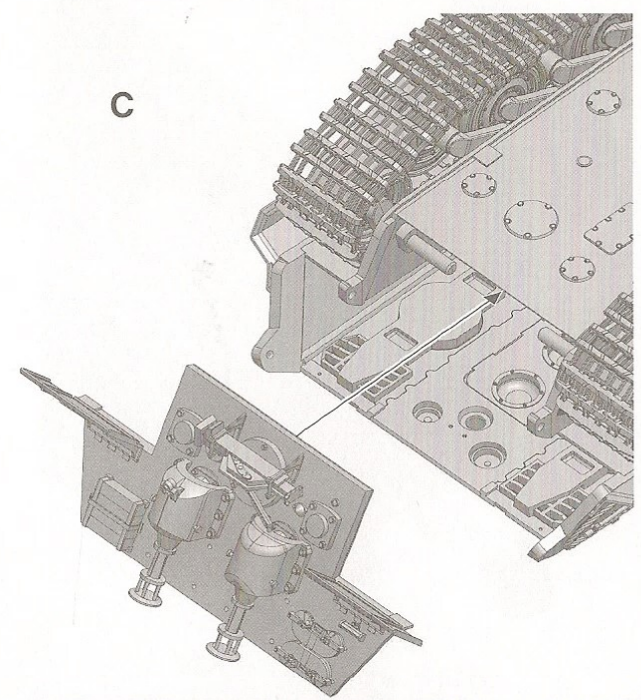

27

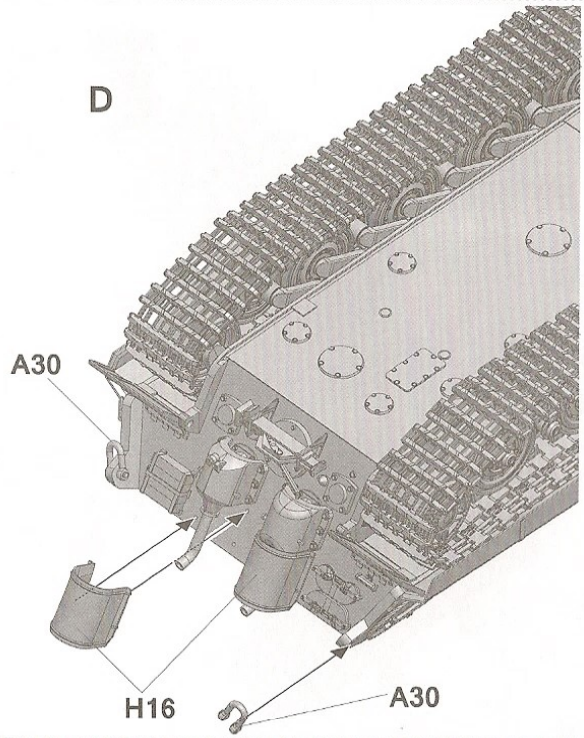
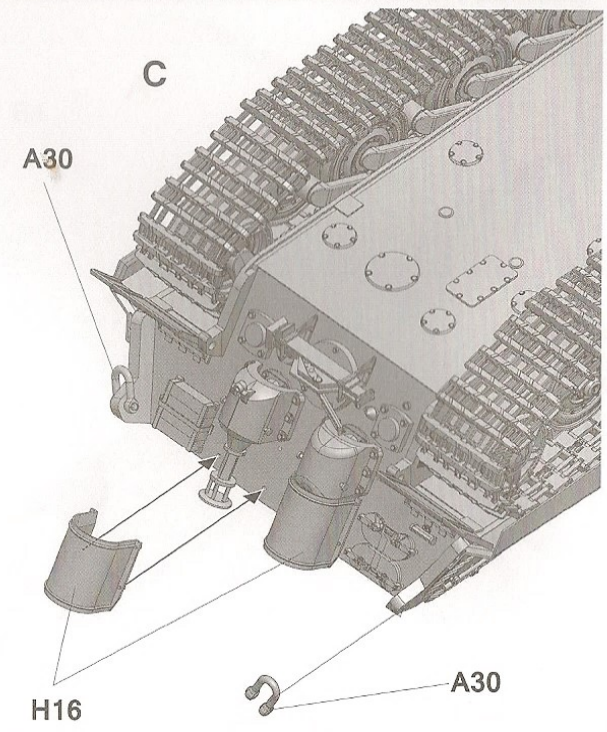
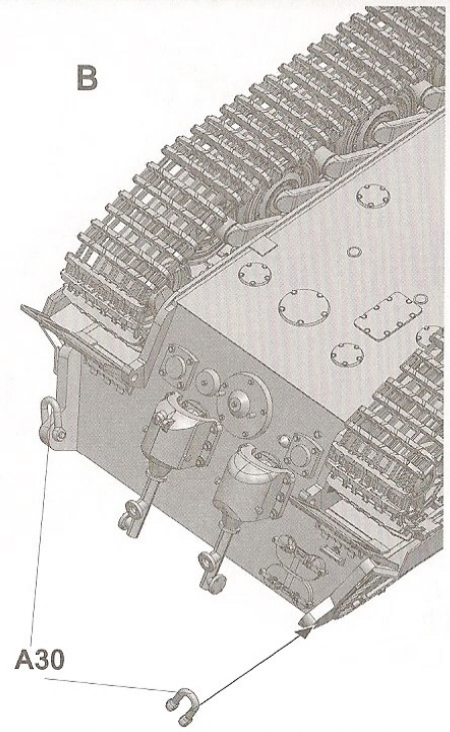
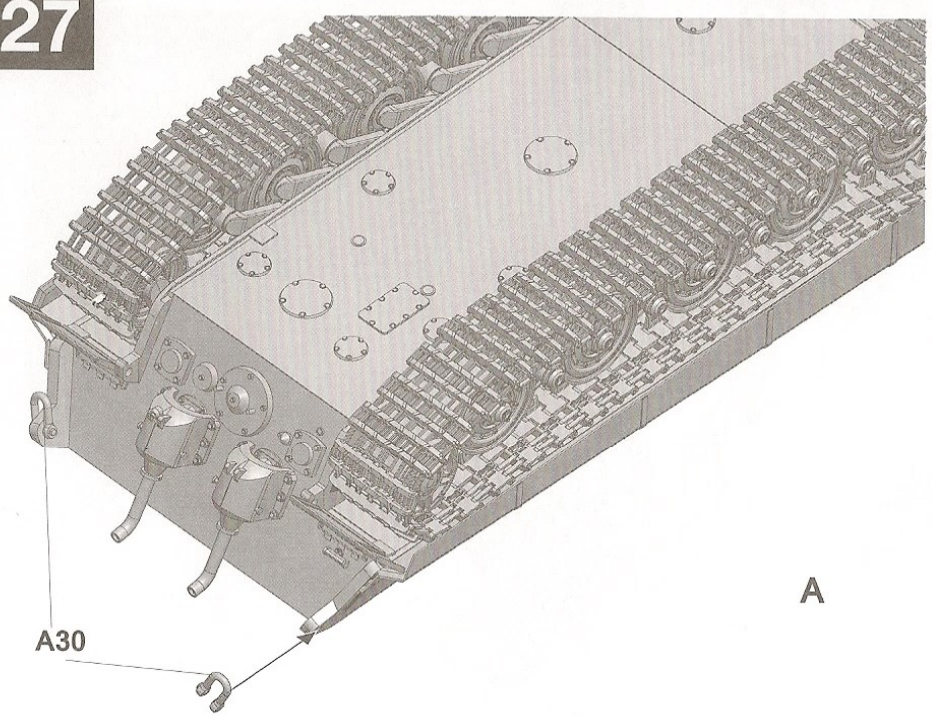

28

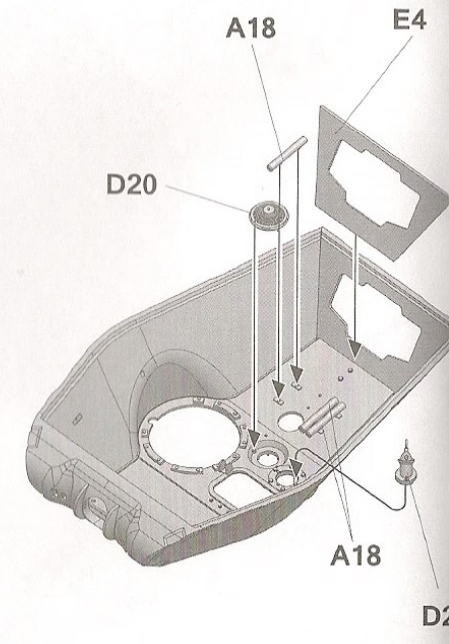
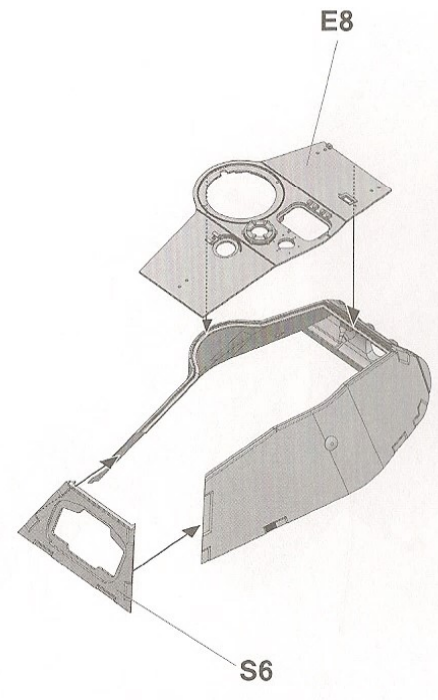
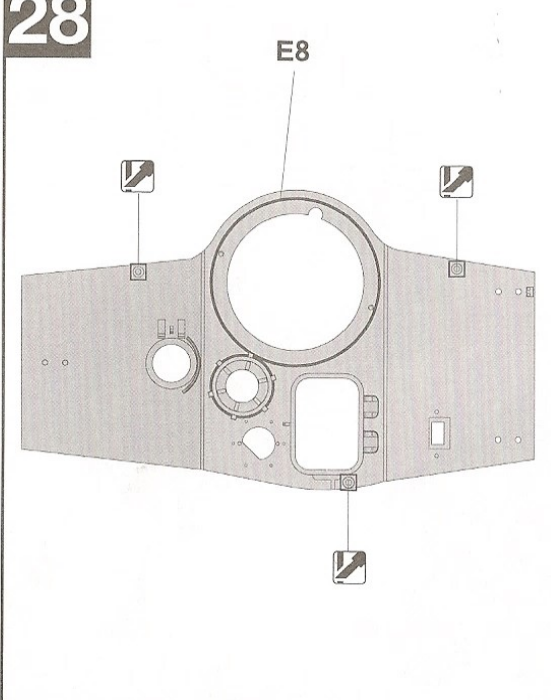

29

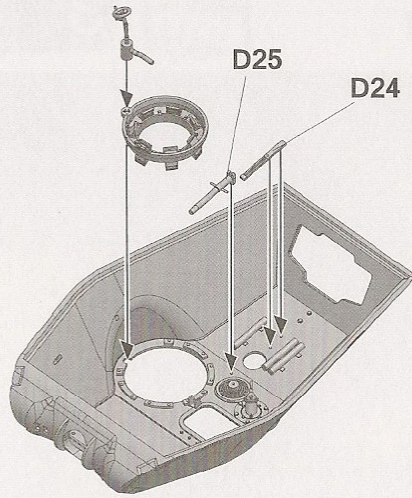
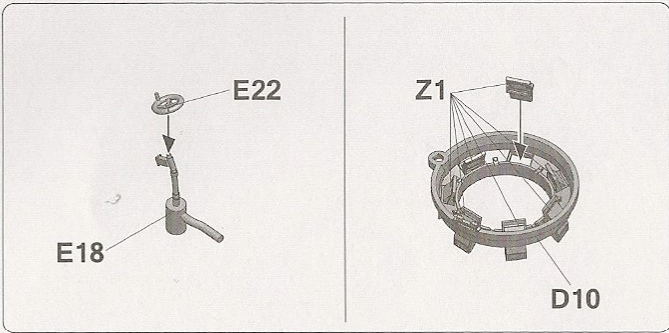

30

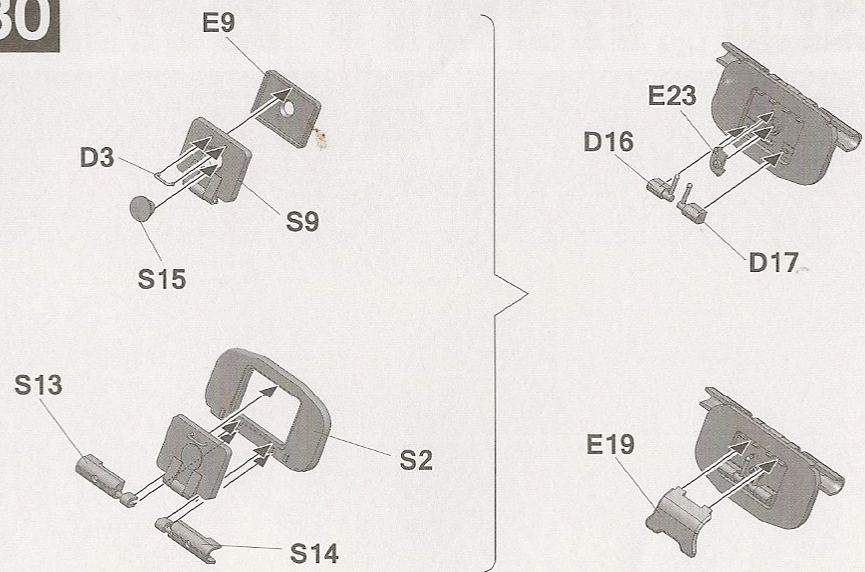

31

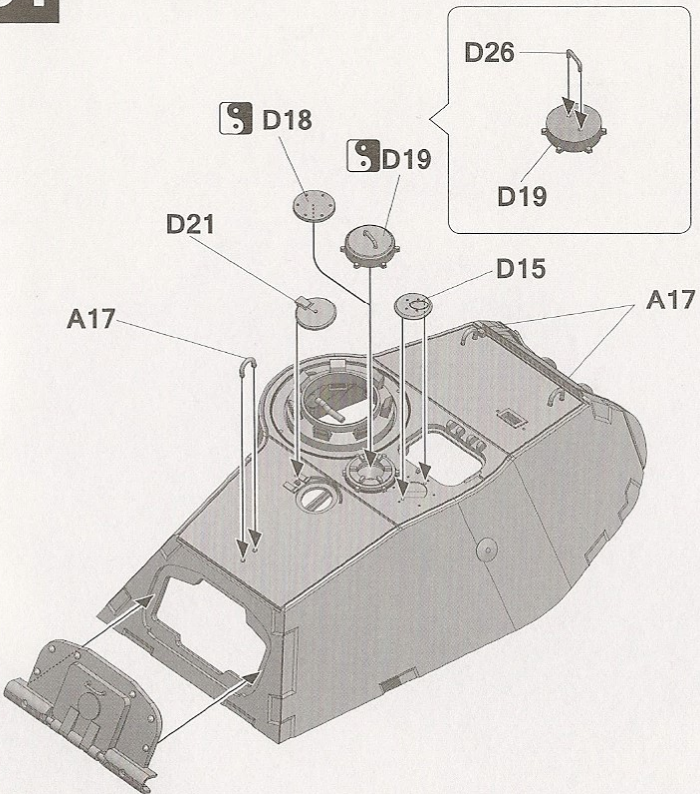

32

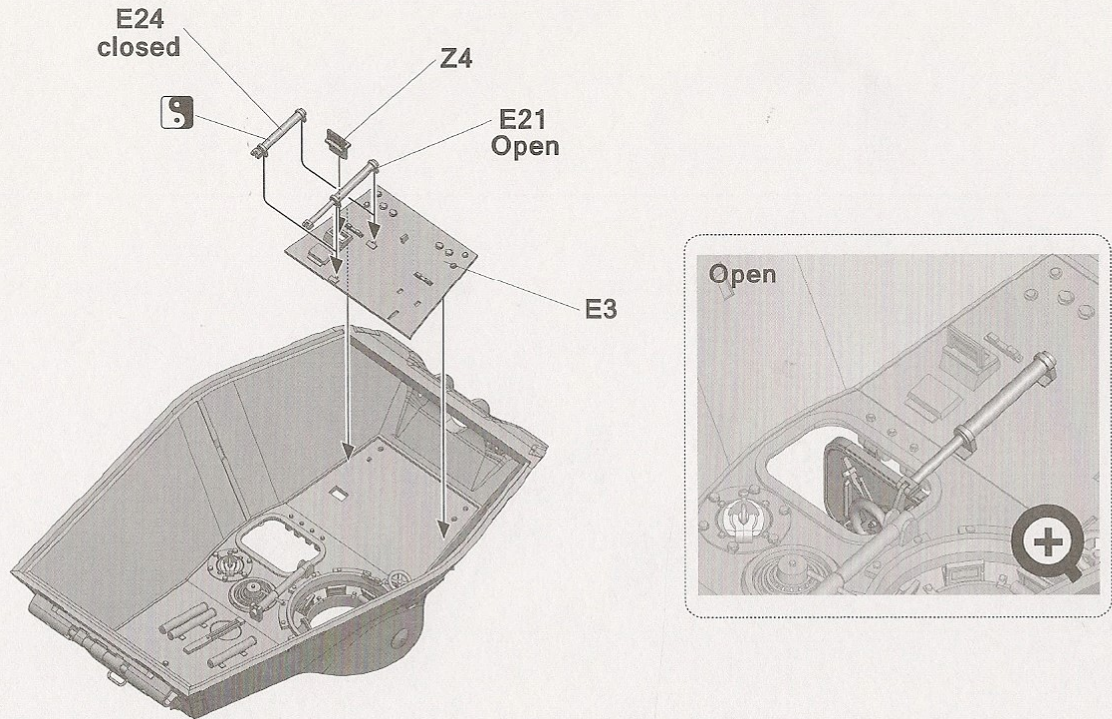

33

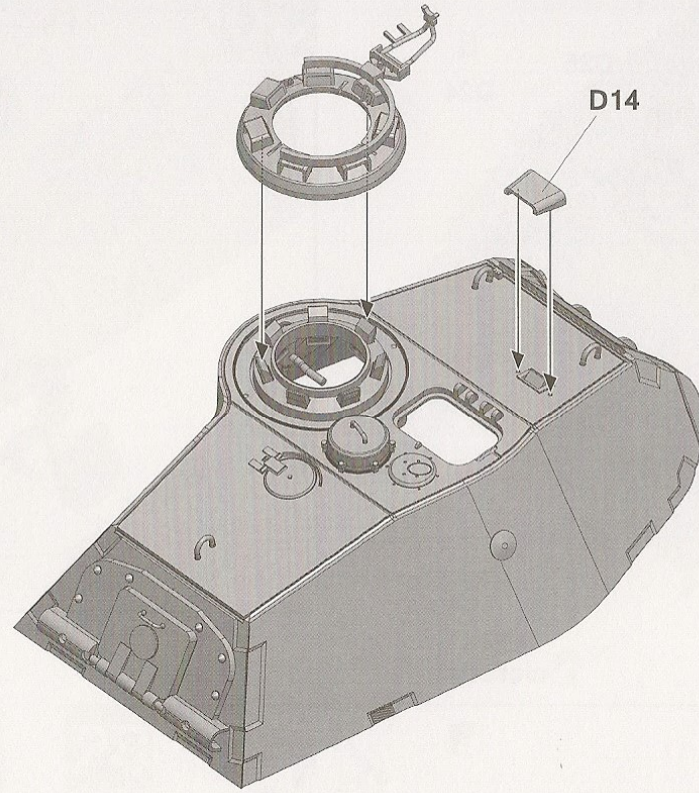
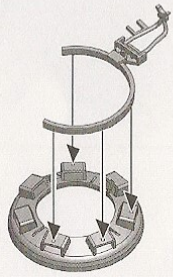
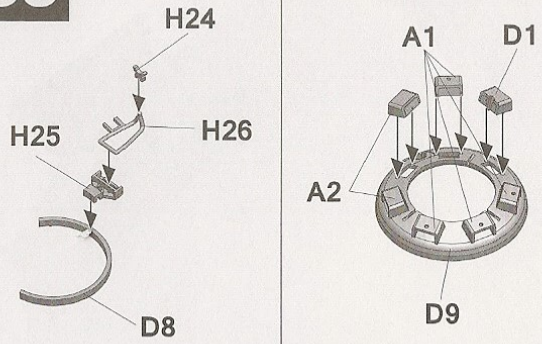

35

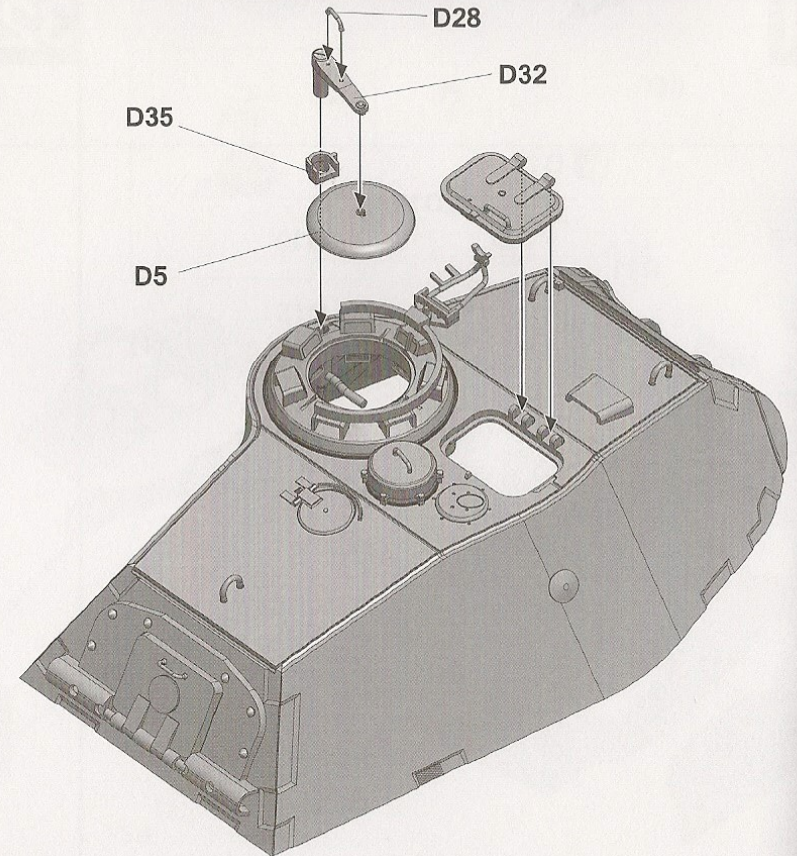
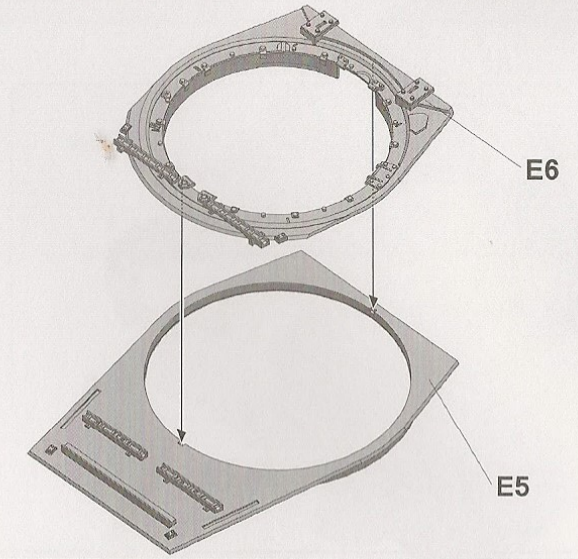

34

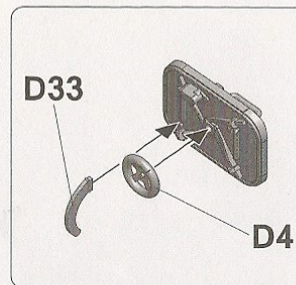
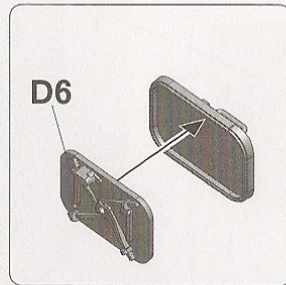

Painting and Marking Guide

- A.MIG 035** Dark Tracks
- A.MIG 040** Medium Rust
- A.MIG 045** Gun Metal
- A.MIG 096** Crystal Periscope Green
- A.MIG 010** Dunkelgelb (Mid War)
- A.MIG 014** Ralbraun
- A.MIG 907** Grey Dark Base

November 1943, Henschel Factory.

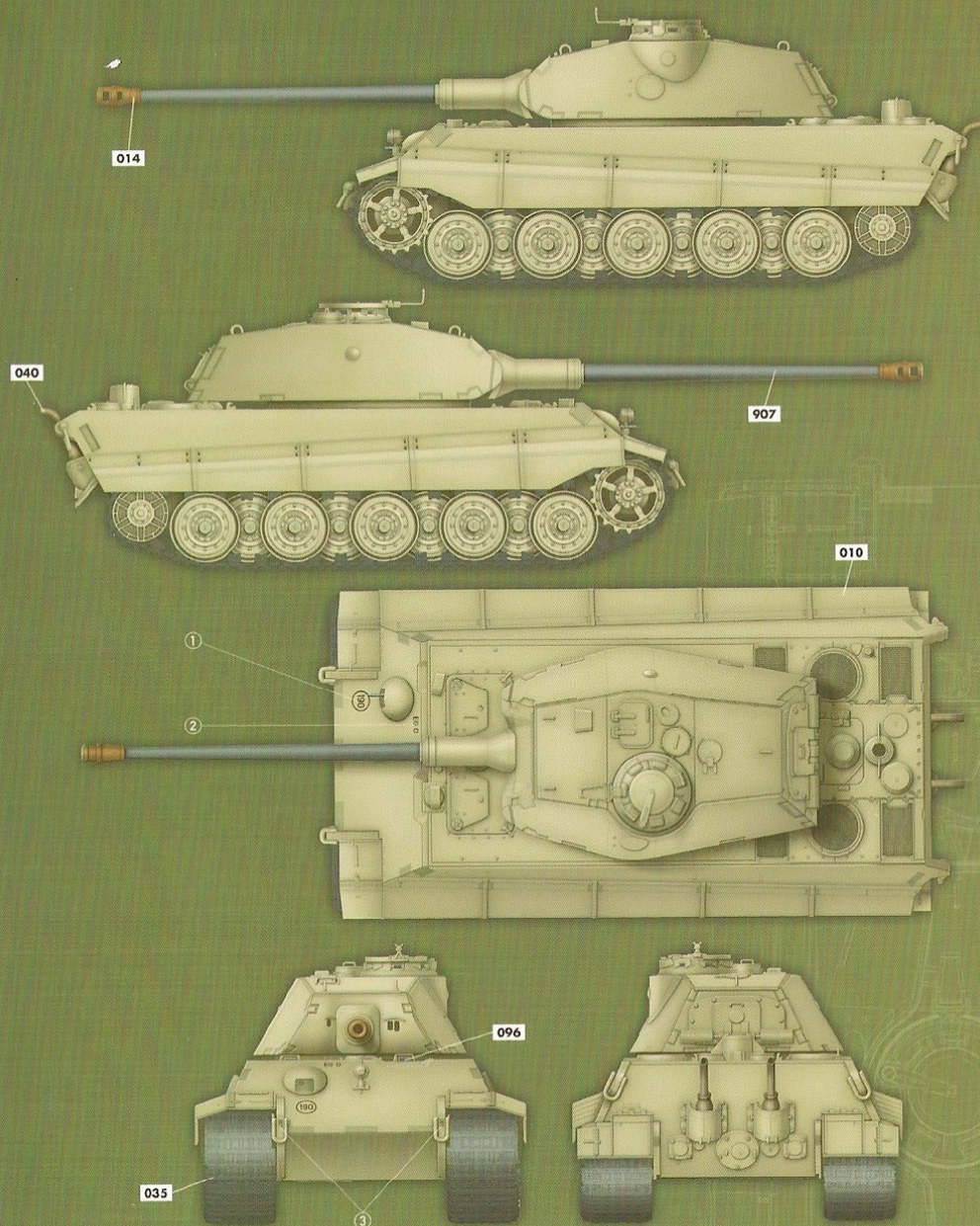

Painting and Marking Guide

- A.MIG 035** Dark Tracks
- A.MIG 037** New Wood
- A.MIG 040** Medium Rust
- A.MIG 045** Gun Metal
- A.MIG 096** Crystal Periscope Green
- A.MIG 010** Dunkelgelb (Mid War)
- A.MIG 014** Ralbraun
- A.MIG 907** Grey Dark Base

November 1943, Henschel Factory.



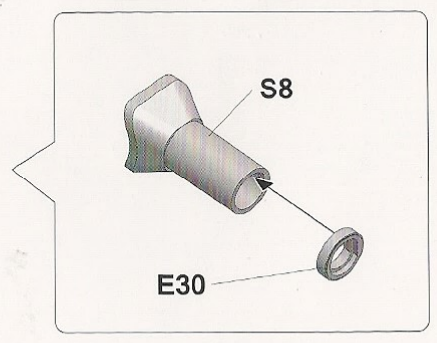
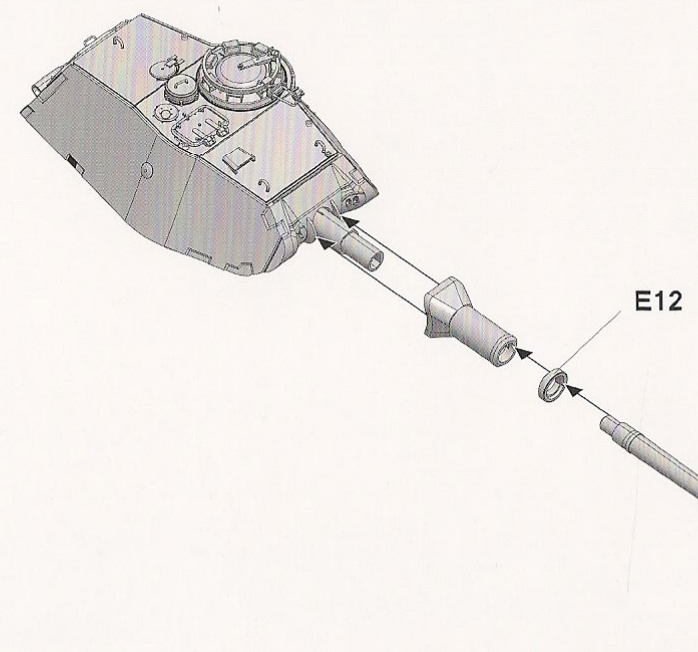
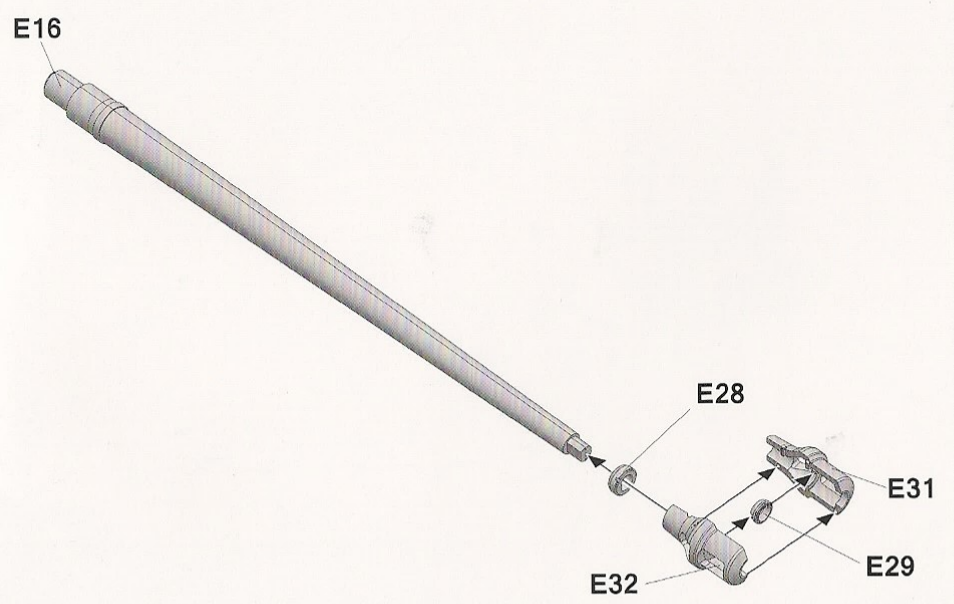
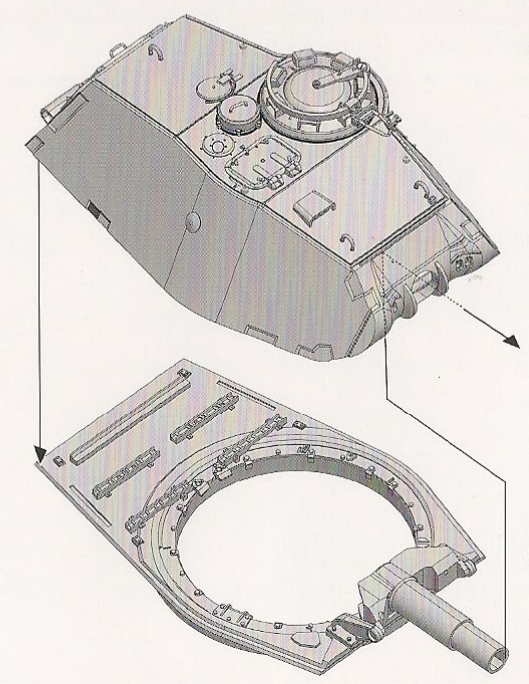
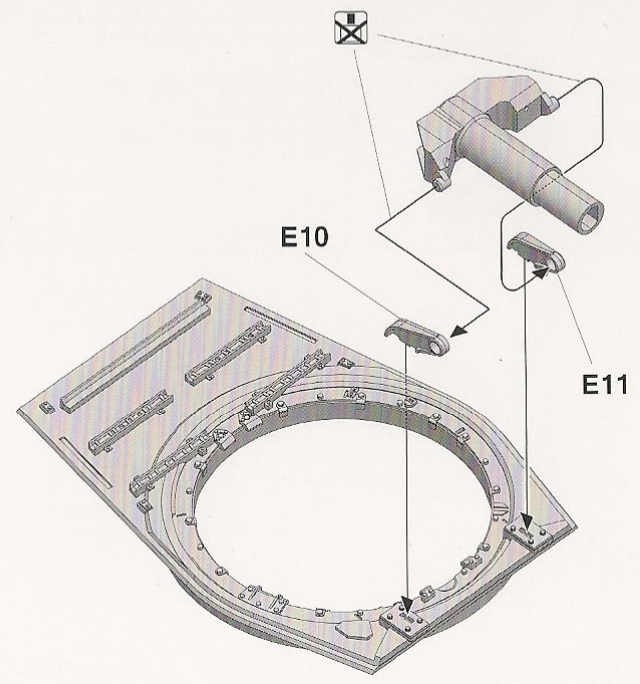
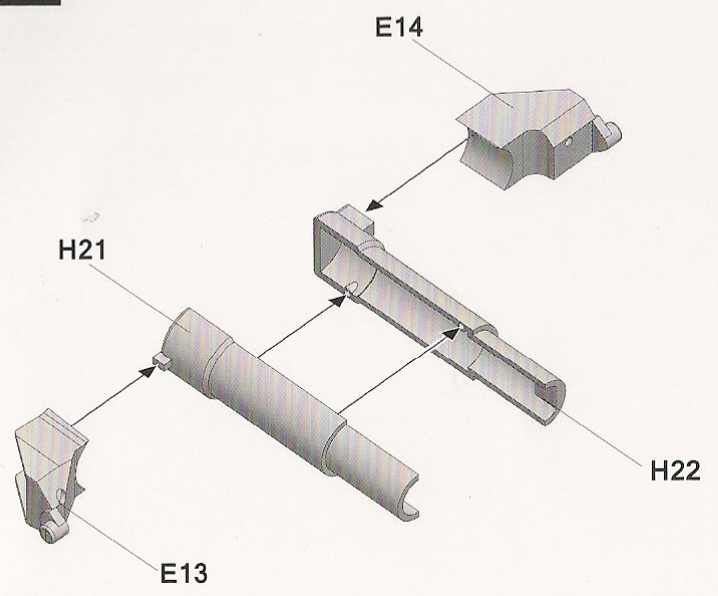

Painting and Marking Guide

- A.MIG 035 Dark Tracks
- A.MIG 037 New Wood
- A.MIG 045 Gun Metal
- A.MIG 096 Crystal Periscope Green
- A.MIG 010 Dunkelgelb (Mid War)
- A.MIG 014 Rotbraun
- A.MIG 907 Grey Dark Base

November 1943, Henschel Factory.

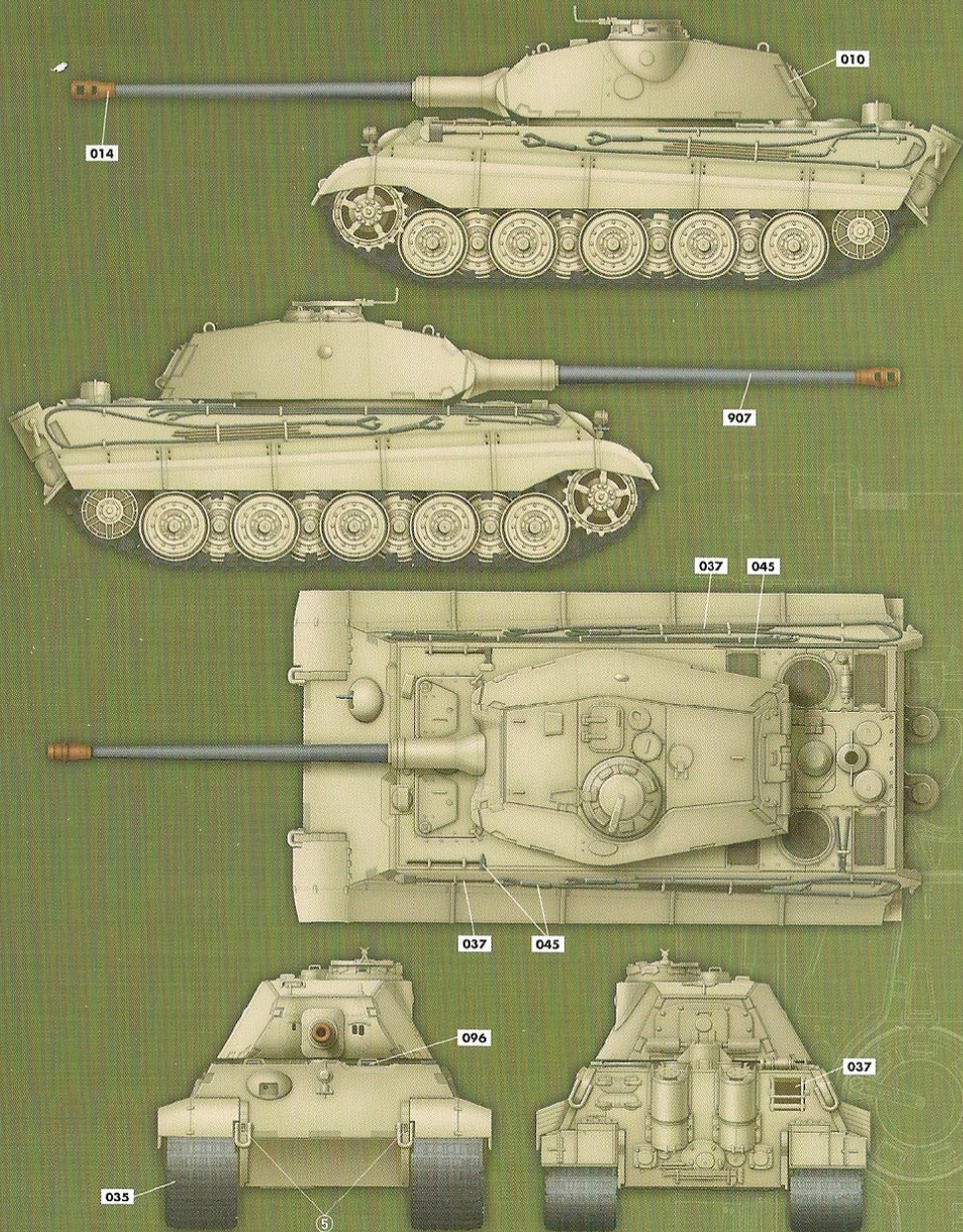

Painting and Marking Guide

- A.MIG 035 Dark Tracks
- A.MIG 037 New Wood
- A.MIG 040 Medium Rust
- A.MIG 045 Gun Metal
- A.MIG 096 Crystal Periscope Green
- A.MIG 008 Dunkelgrau

January 1944, Henschel tank testing grounds, Haustenbeck, Germany.

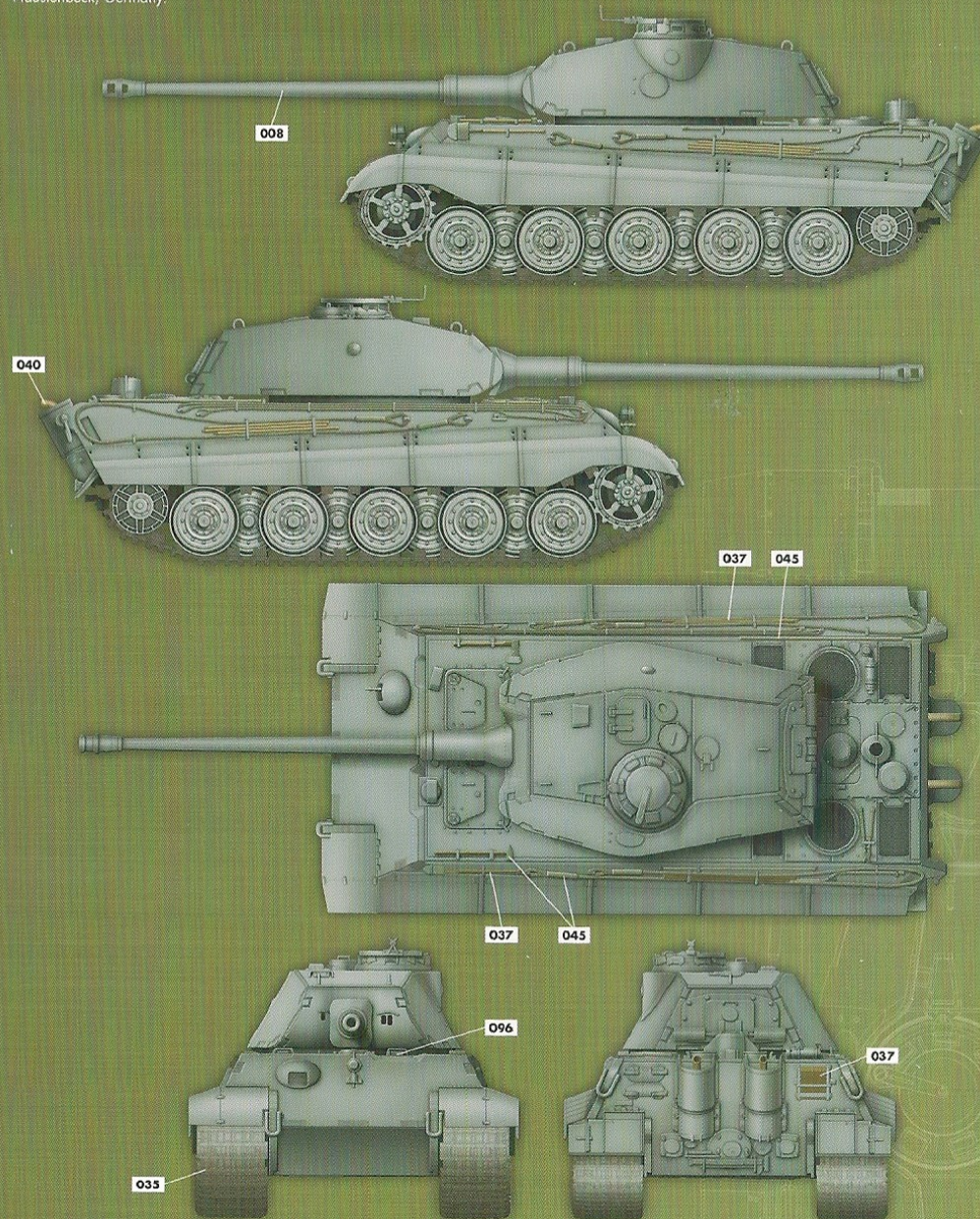

2017/2096

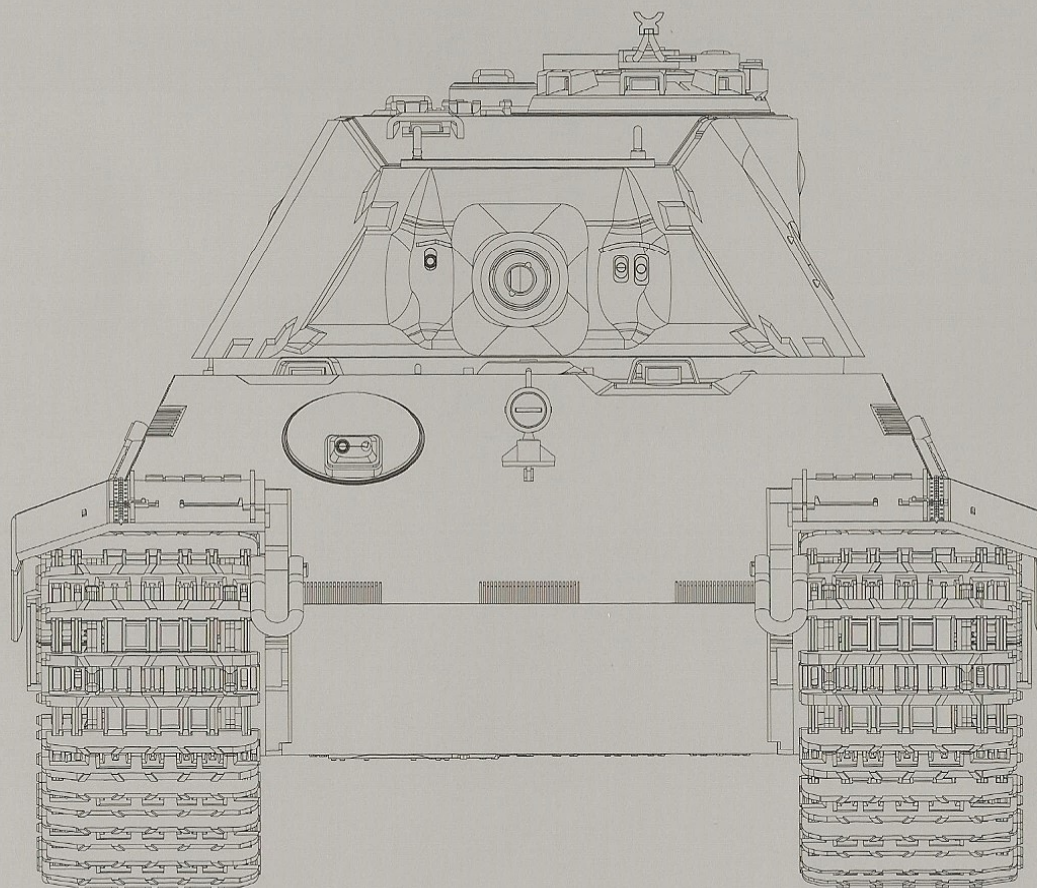

You can find TAKOM on Facebook.com