



KIT5976

85597600200

# A-4F SKYHAWK

Created by Ed Heinemann, the brilliant aircraft engineer at the Douglas Aircraft Company who produced many of America's finest combat aircraft, the A-4 Skyhawk was conceived as a small, lightweight jet attack aircraft which would be capable of operating from aircraft carriers. The final design was so small that it did not require folding wings as used on most carrier-based aircraft. The reduced weight, simplified design, and the small size did not mean that the Skyhawk was not a very capable aircraft. Assigned to both Navy and Marine attack squadrons, the A-4 Skyhawk was used extensively during the war in Vietnam where it gained a reputation for being rugged and reliable. It was equally effective in the strategic bombing campaign and in providing close air support for soldiers on the ground. The A-4 was also very valuable in non-combat roles as well. Two-seat versions were used extensively as advanced jet trainers, and A-4Fs were also used by the Navy's famous precision flight demonstration team, the Blue Angels.

Your Revell model comes with markings for an A-4F from Marine attack squadron VMFA-324, called the "Devildogs". The second set of markings allows you to build any one of four aircraft from the Blue Angels team of 1978.

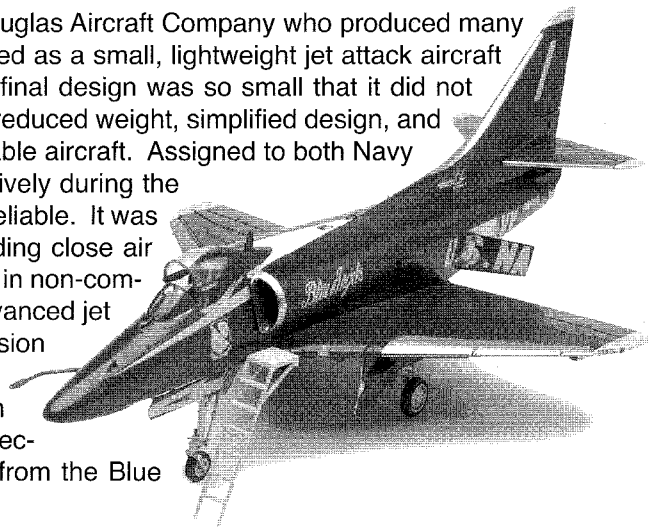

\* REPEAT SEVERAL TIMES  
\* A REPETER PLUSIEURS FOIS



\* OPTIONAL PARTS  
\* PIECES EN OPTION



\* DECAL  
\* DECAL COMANIE



\* ALTERNATIVE ASSEMBLY  
\* ENSEMBLAGE ALTERNATIVE



\* CEMENT TOGETHER  
\* A COLLER



\* REMOVE AND THROW AWAY  
\* A RETIRER ET JETER



\* DO NOT CEMENT  
\* NE PAS COLLER

### READ THIS BEFORE YOU BEGIN

- \* Study the assembly drawings.
- \* Each plastic part is identified by a number.
- \* For better paint and decal adhesion, wash the plastic parts in a mild detergent solution. Rinse and let air dry.
- \* Check the fit of each piece before cementing in place.
- \* Use only cement for polystyrene plastic.
- \* Scrape plating and paint from areas to be cemented.
- \* Allow paint to dry thoroughly before handling parts.
- \* Any unused parts may be discarded.

### DECAL APPLICATION INSTRUCTIONS

1. Cut desired decal from sheet.
2. Dip decal in water for a few seconds.
3. Place wet decal on paper towel.
4. Wait until decal is movable on paper backing.
5. Place decal in position on model, face up and slide backing away.
6. Press out air bubbles with a soft damp cloth.
7. Milkyness that may appear is for better decal adhesion and will dry clear. Wipe away any excess adhesive.
8. Do not touch decal until fully dry.
9. Allow the decals 48 hours to dry before applying clear coat.

**NOTE:** Decals are compatible with setting solutions or solvents.

### LIRE CE QUI SUIV AVANT DE COMMENCER

- \* Etudier les schémas de montage.
- \* Chaque pièce en plastique est identifiée par un numéro.
- \* Pour une meilleure prise de la peinture et des autocollants, laver les pièces en plastique avec une solution détergente peu concentrée. Les rincer et les laisser sécher à l'air.
- \* Vérifier que chaque pièce s'ajuste bien avant de la coller en place.
- \* N'utiliser que de la colle pour polystyrène.
- \* Gratter les parties à coller pour enlever le chrome et la peinture.
- \* Laisser la peinture bien sécher avant de manipuler les pièces.
- \* Toute pièce inutilisée peut être jetée.

### DIRECTIVES D'APPLICATION DES AUTOCOLLANTS

1. Découper l'autocollant désiré de la feuille.
2. Tremper l'autocollant dans de l'eau pendant quelques secondes.
3. Placer l'autocollant mouillé sur une serviette en papier.
4. Attendez que l'autocollant puisse être déplacé sur son support en papier.
5. Mettre l'autocollant en position sur le modèle face sur le dessus et faire glisser le support pour l'enlever.
6. Appuyer avec un chiffon doux humide pour éliminer les bulles d'air.
7. La substance laiteuse qui peut apparaître est destinée à améliorer l'adhésion de l'autocollant et devient incolore au séchage. Essuyer pour enlever tout excédent d'adhésif.
8. Ne pas toucher l'autocollant tant qu'il n'est pas bien sec.
9. Laisser l'autocollant sécher pendant 48 heures avant d'appliquer une couche transparente.

**REMARQUE:** Les autocollants sont compatibles avec les solutions de fixation ou les solvants.

### This optional paint guide is provided if you choose to detail paint your model.

Ce guide de peinture vous sera fourni si vous choisissez de peindre votre modèle en détail.

Blue Angels Blue	FS 15050	Bleu angélique
Burnt Iron		Brûlé métal
Dark Gull Gray	FS 36231	Gris cendré foncé
Flat Black	FS 37038	Noir mat
Flat White	FS 37875	Blanc mat
Gloss Dark Green	FS 14090	Vert foncé lustré
Gloss White	FS 17875	Blanc lustré
Insignia Red	FS 11136	Rouge emblème
Light Gull Gray	FS 36440	Gris cendré clair
Olive Drab	FS 34978	Olivet
Polished Aluminum		Aluminium clair
Silver		Argent
Steel		Acier

If you have any questions or comments, call our hotline at: **(800) 833-3570** or, please write to:

Revell-Monogram Consumer Service Department, 8601 Waukegan Road, Morton Grove, Illinois 60053  
Be sure to include the plan number (85597600200), part number, description, your return address and phone number.

Visit our website: [www.revell-monogram.com](http://www.revell-monogram.com)

# 1

# SEAT / COCKPIT ASSEMBLY

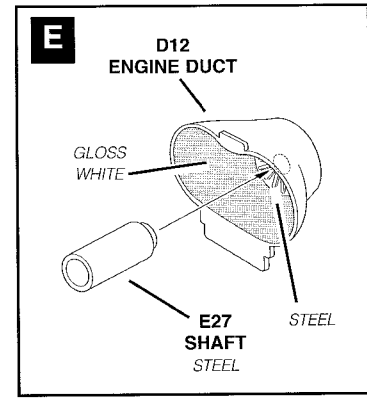
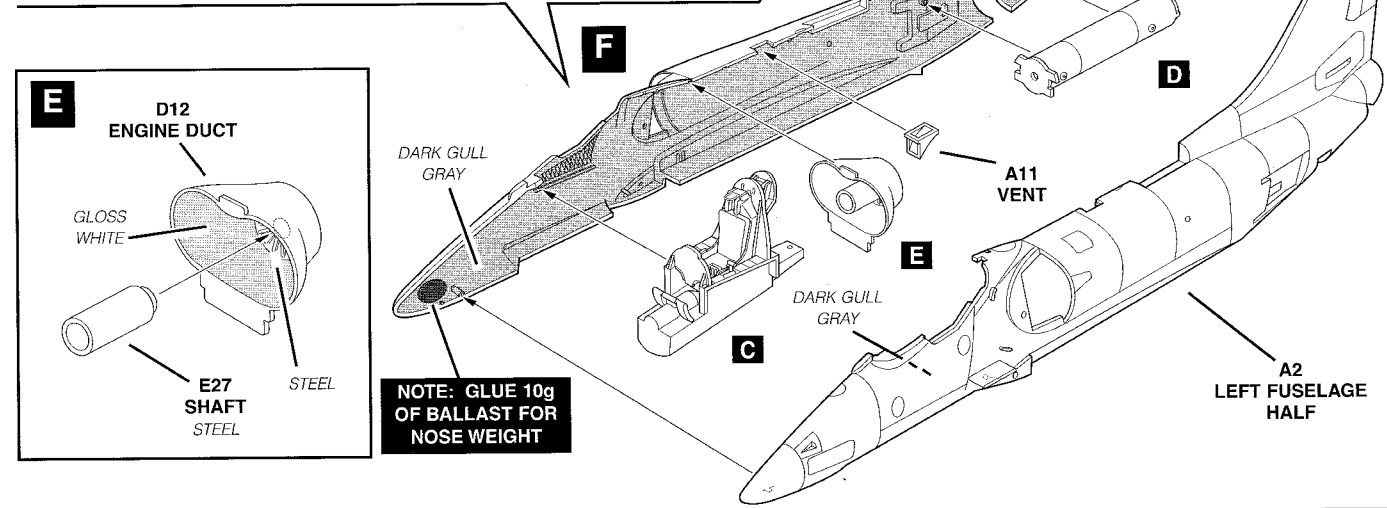
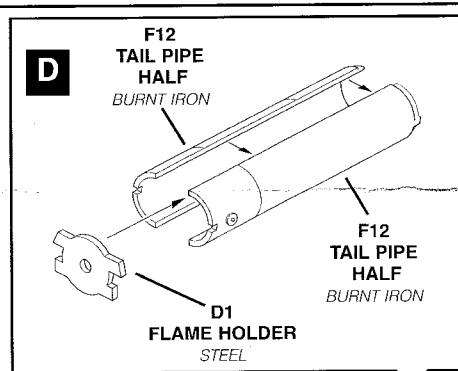
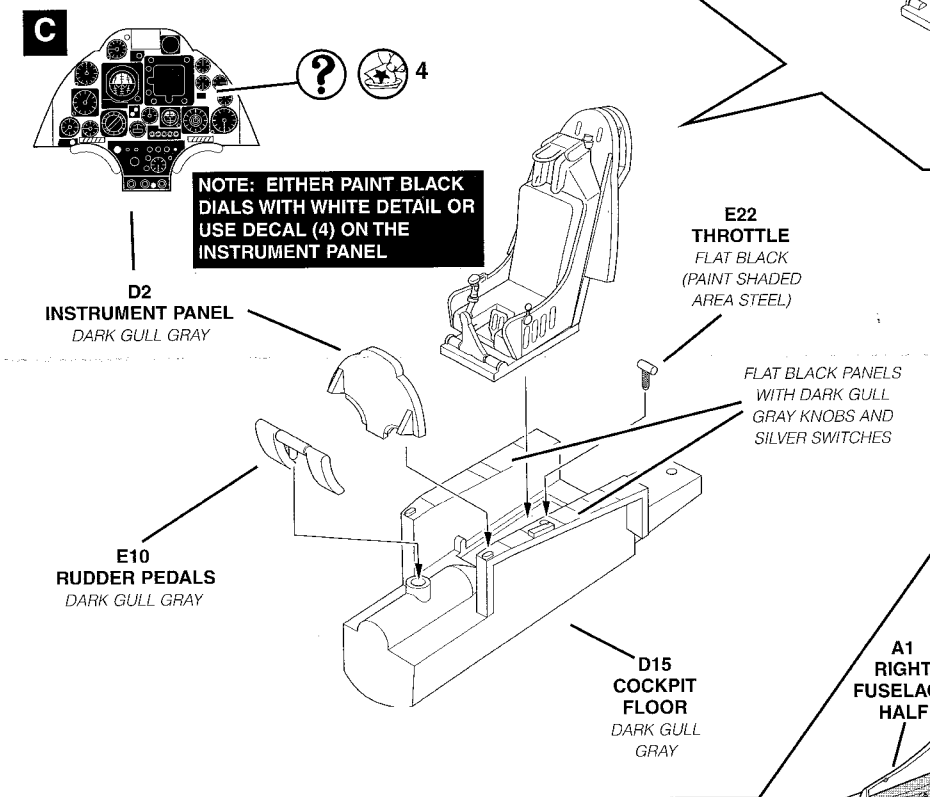
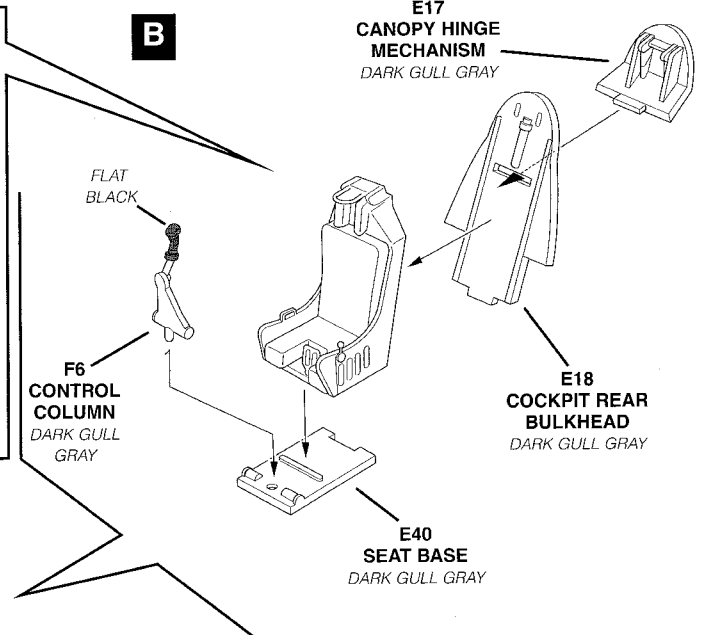
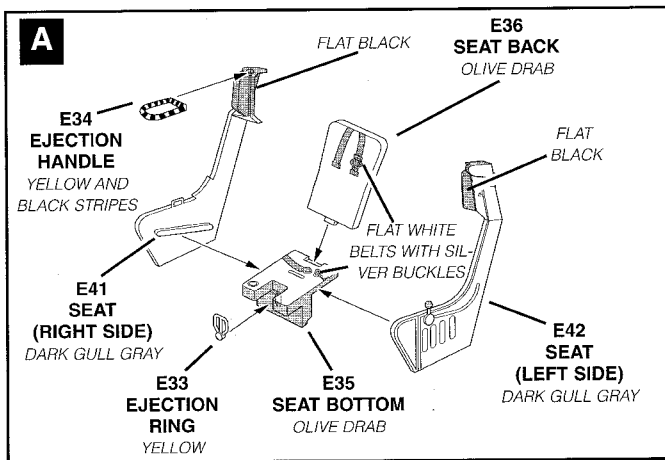

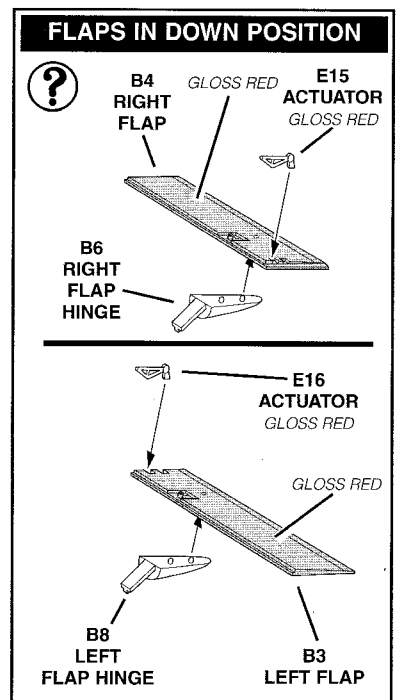
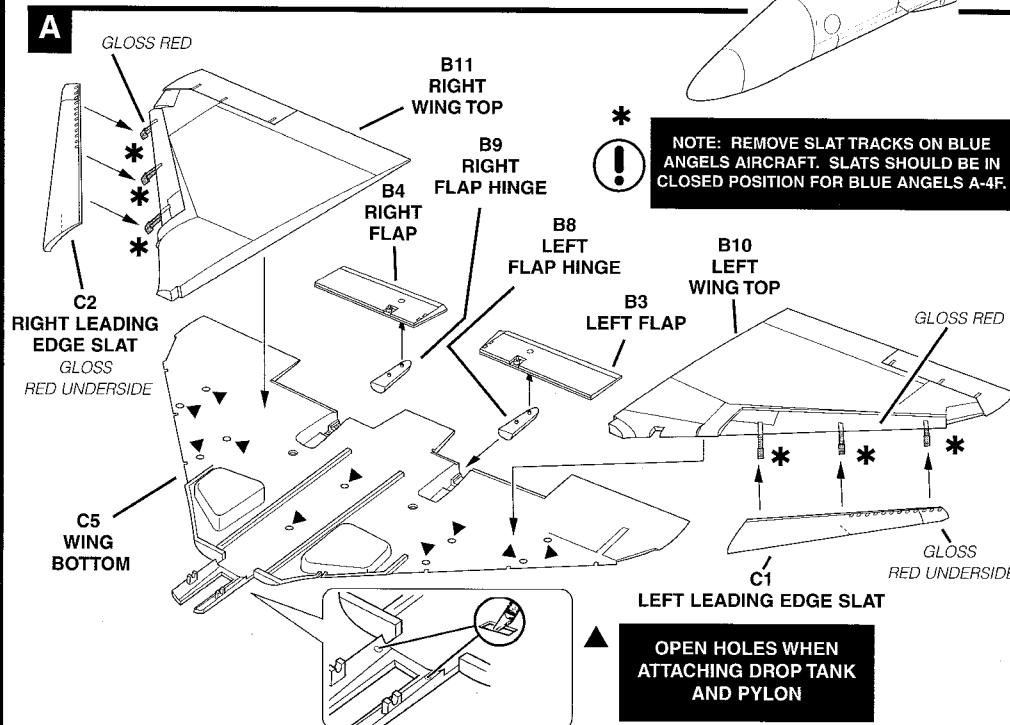
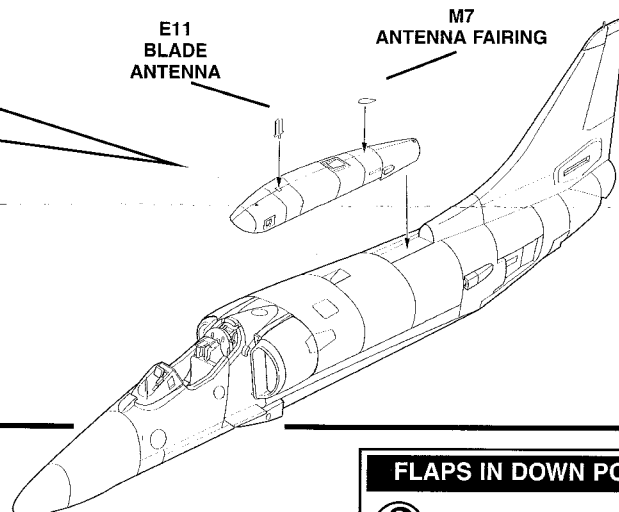
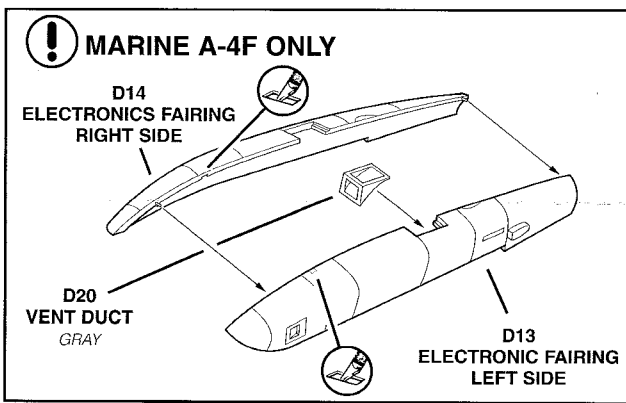
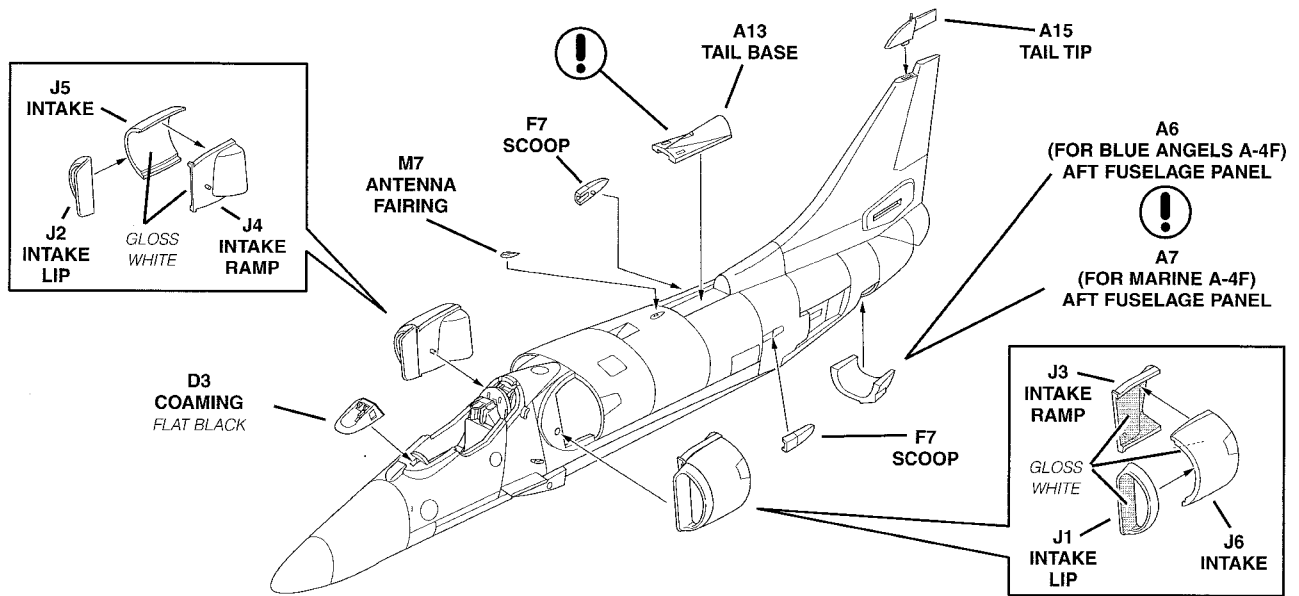

# 3

# WING ASSEMBLY CONTINUED

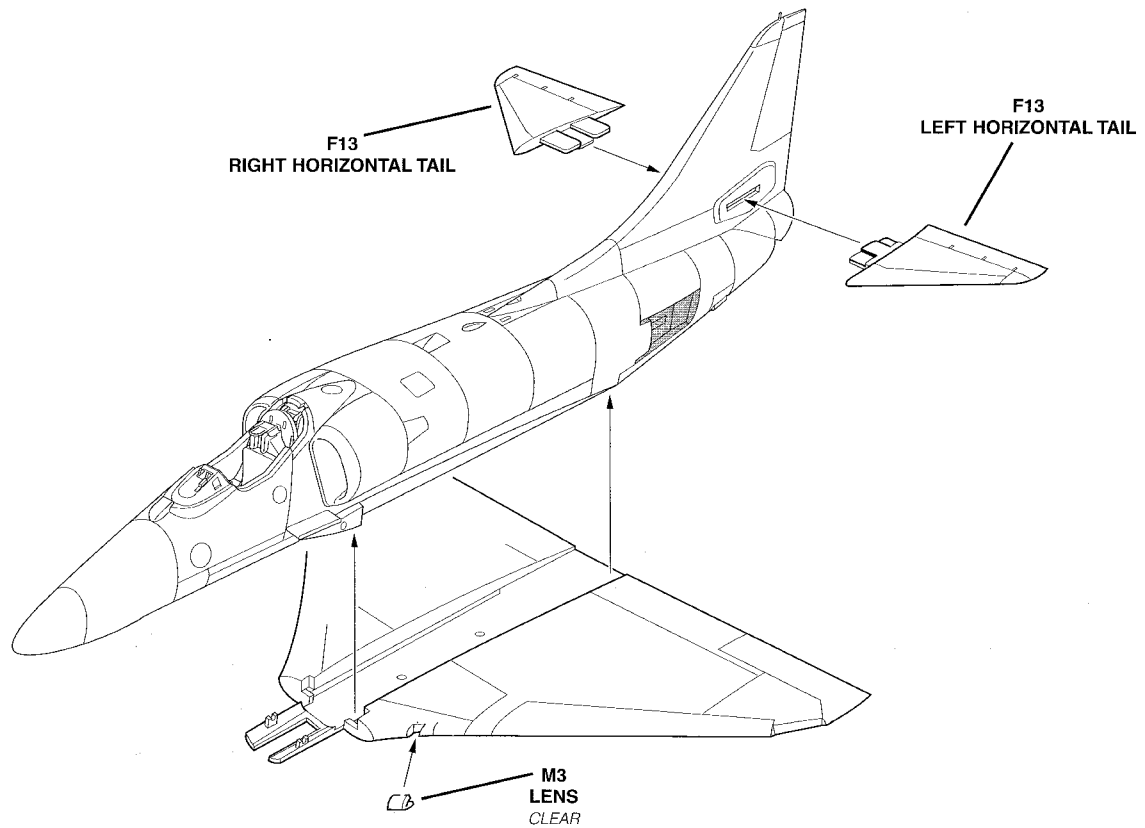

# 4

# NOSE GEAR ASSEMBLY

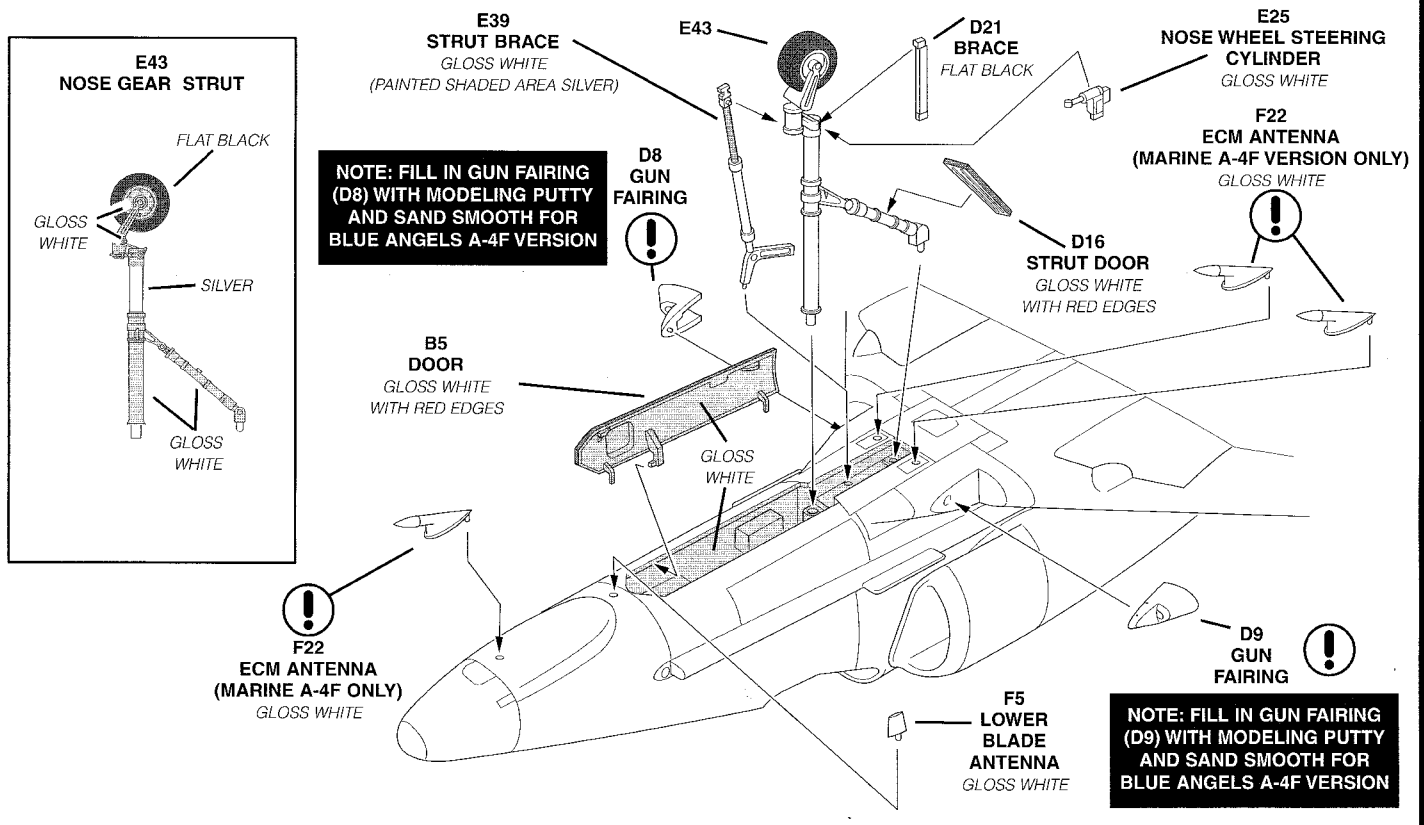

# 5

# MAIN GEAR ASSEMBLY

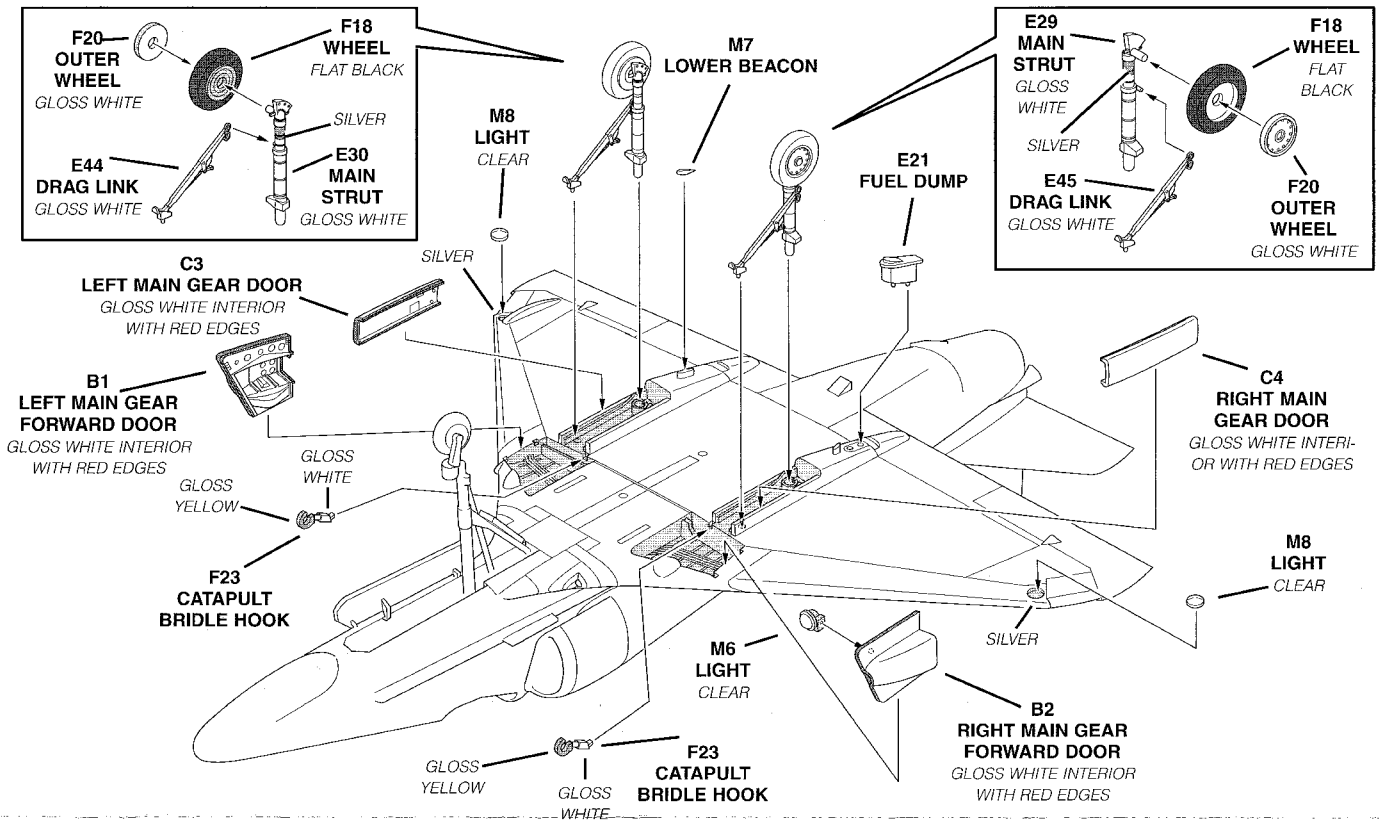

# 6

# TAIL ASSEMBLY

**AIRBRAKES ARE IN OPEN POSITION**

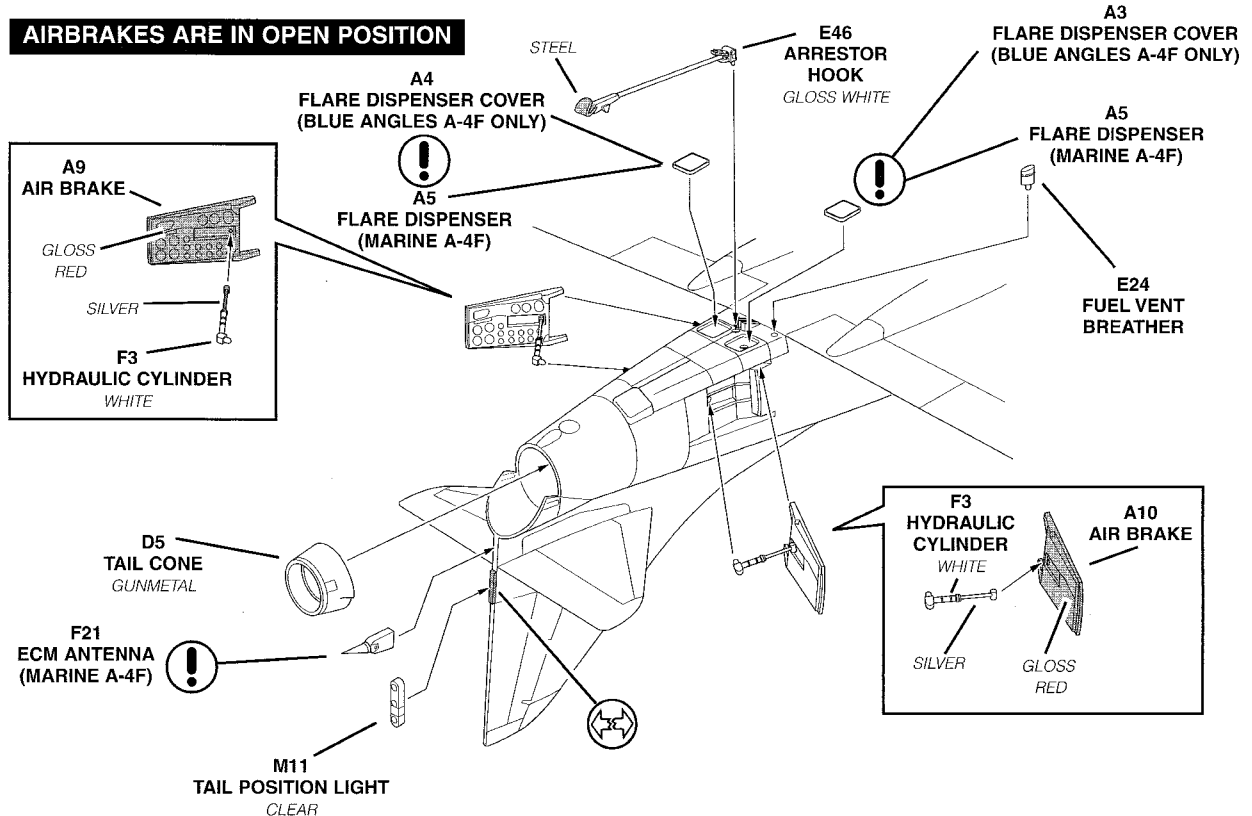

# 7

# TANK ASSEMBLY

**A** (2X) MARINE A-4F ONLY !

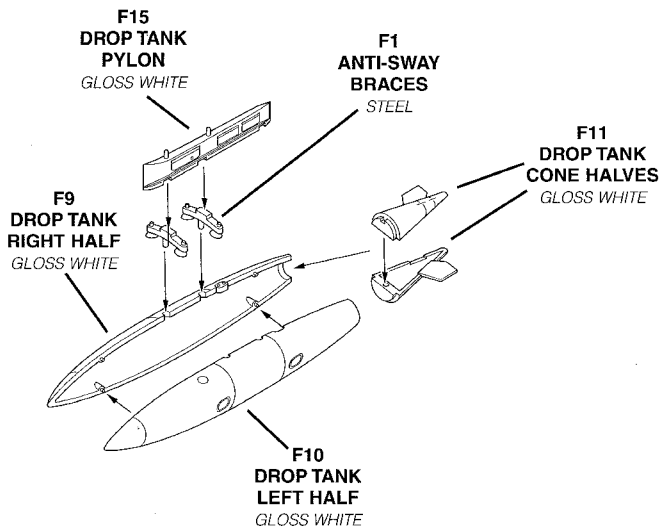

**B** MARINE A-4F ONLY !

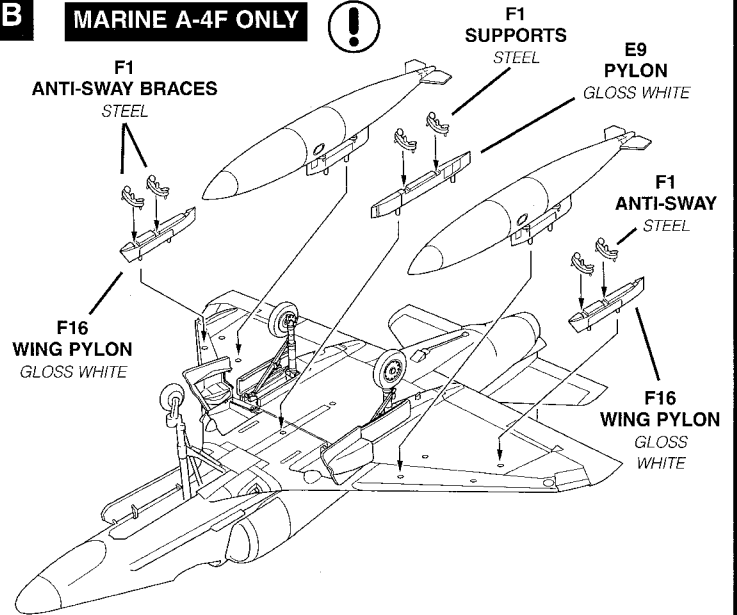

# 8

# FINAL ASSEMBLY

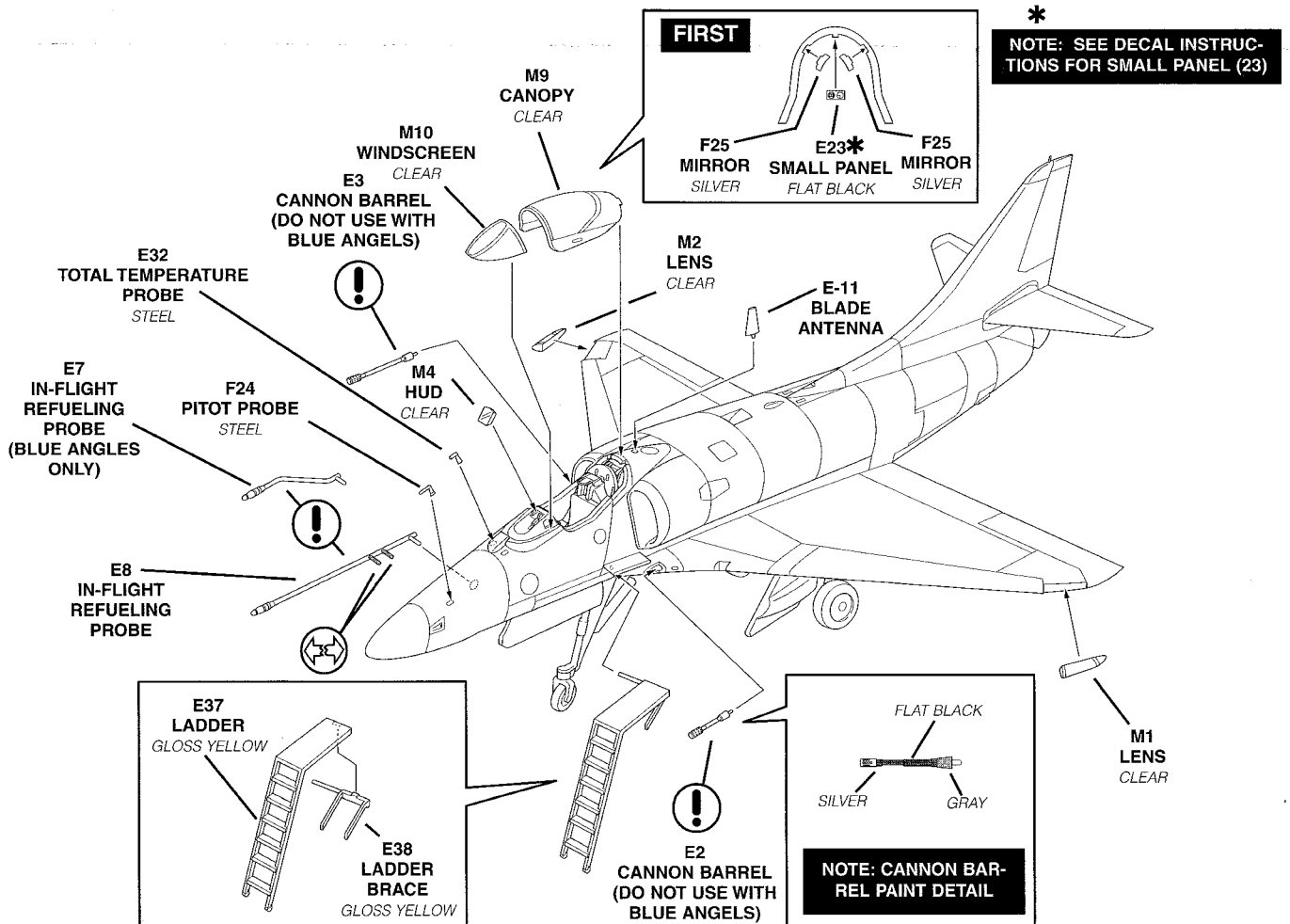

# DECAL PLACEMENT

## *Blue Angels A-4F Skyhawk 1978*

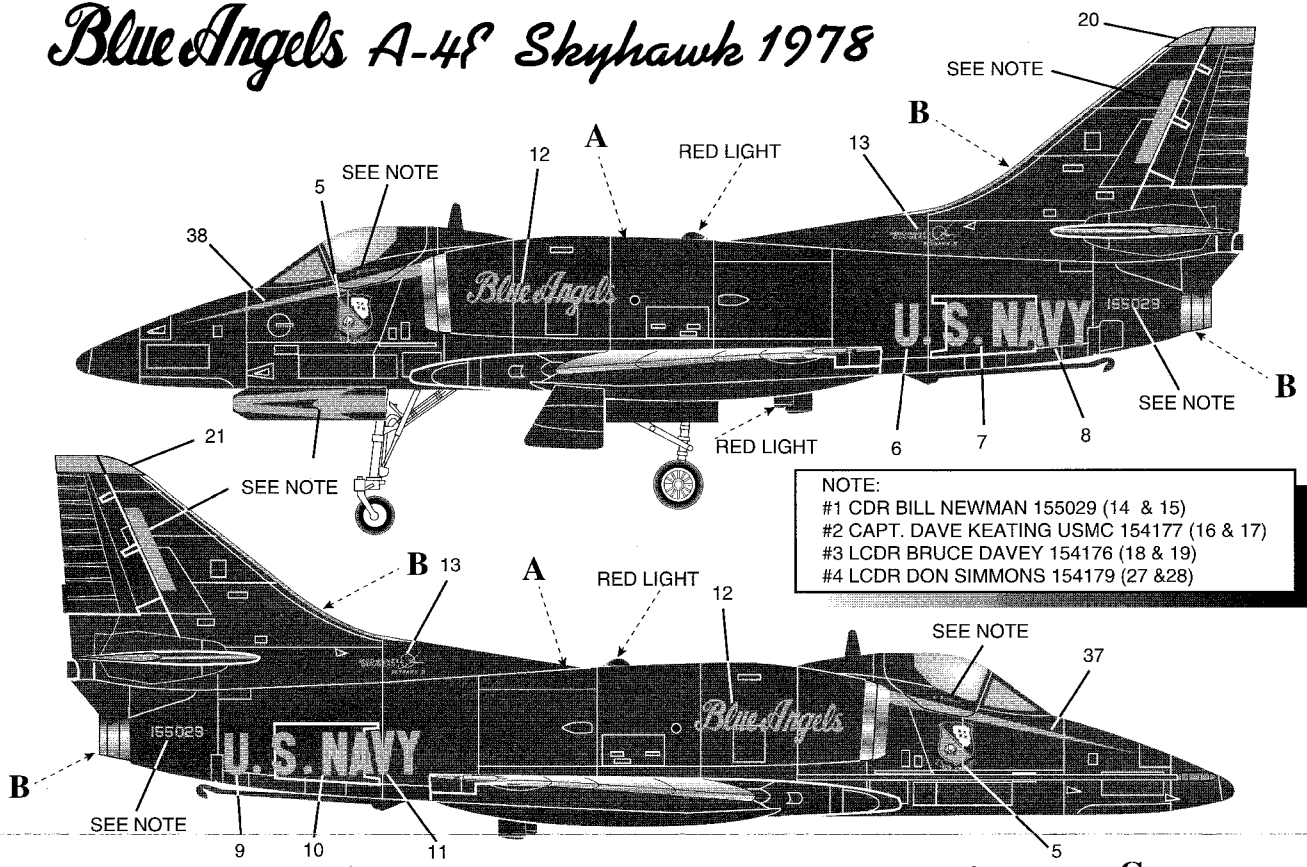

**NOTE:**  
 #1 CDR BILL NEWMAN 155029 (14 & 15)  
 #2 CAPT. DAVE KEATING USMC 154177 (16 & 17)  
 #3 LCDR BRUCE DAVEY 154176 (18 & 19)  
 #4 LCDR DON SIMMONS 154179 (27 & 28)

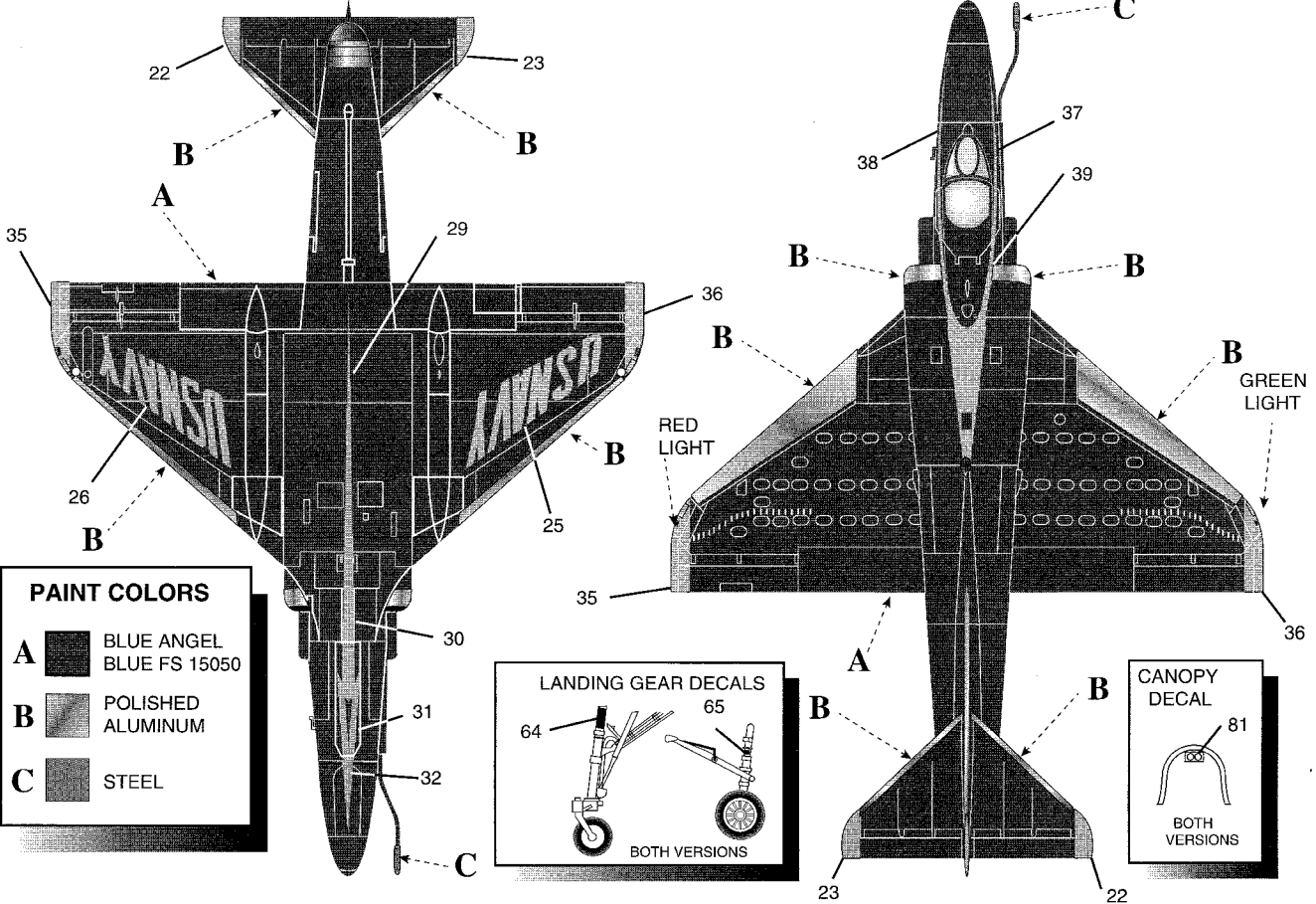

**PAINT COLORS**

<b>A</b>	BLUE ANGEL BLUE FS 15050
<b>B</b>	POLISHED ALUMINUM
<b>C</b>	STEEL

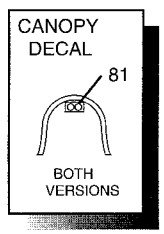
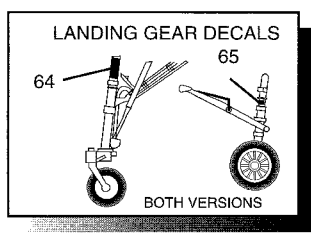

# DECAL PLACEMENT

**A-4F SKYHAWK, BUONO 150056, VMFA-324, DEVILDOGS  
U.S. MARINES, NAF DETROIT, 1971**

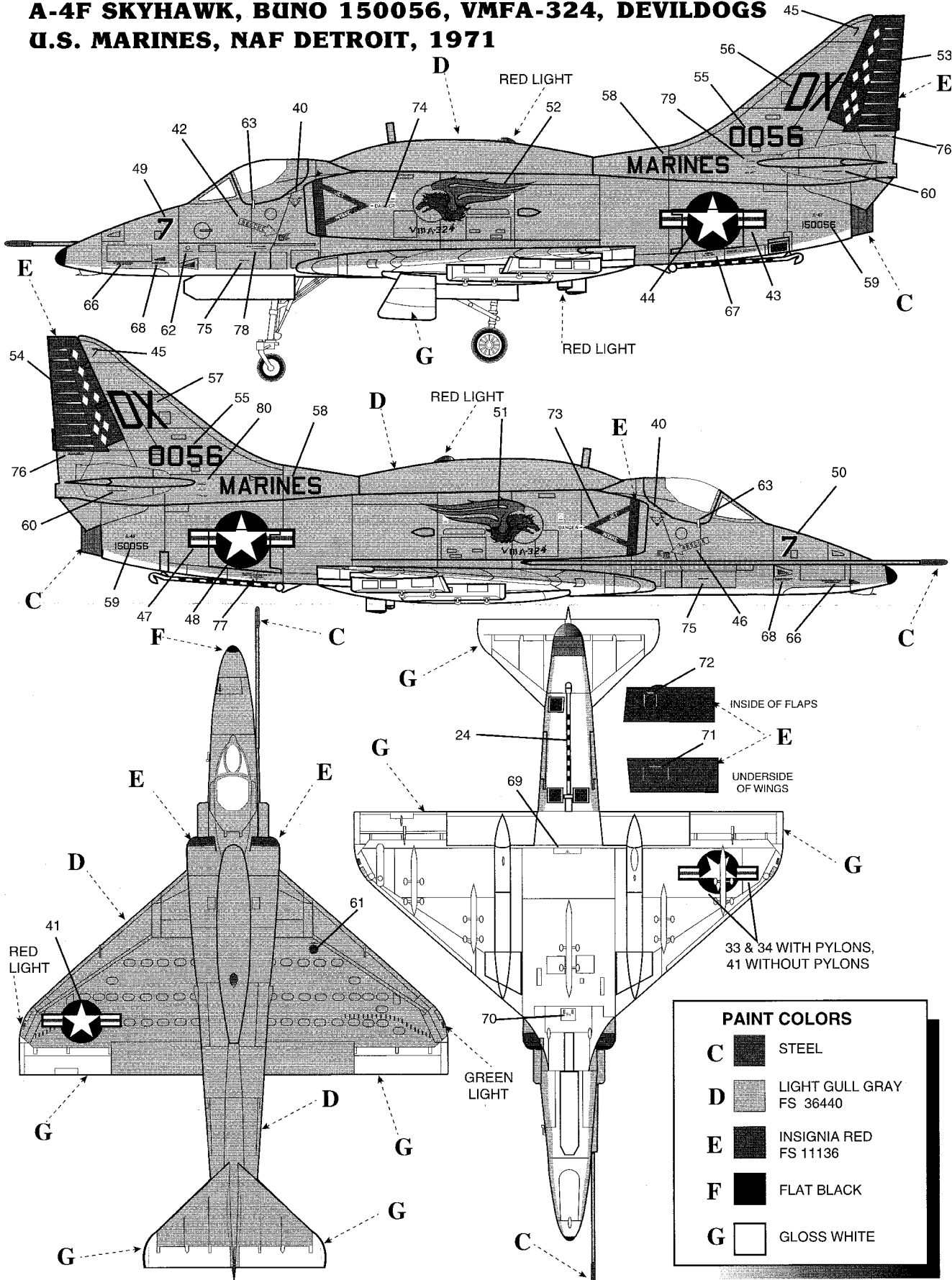

PAINT COLORS	
<b>C</b>	STEEL
<b>D</b>	LIGHT GULL GRAY FS 36440
<b>E</b>	INSIGNIA RED FS 11136
<b>F</b>	FLAT BLACK
<b>G</b>	GLOSS WHITE