

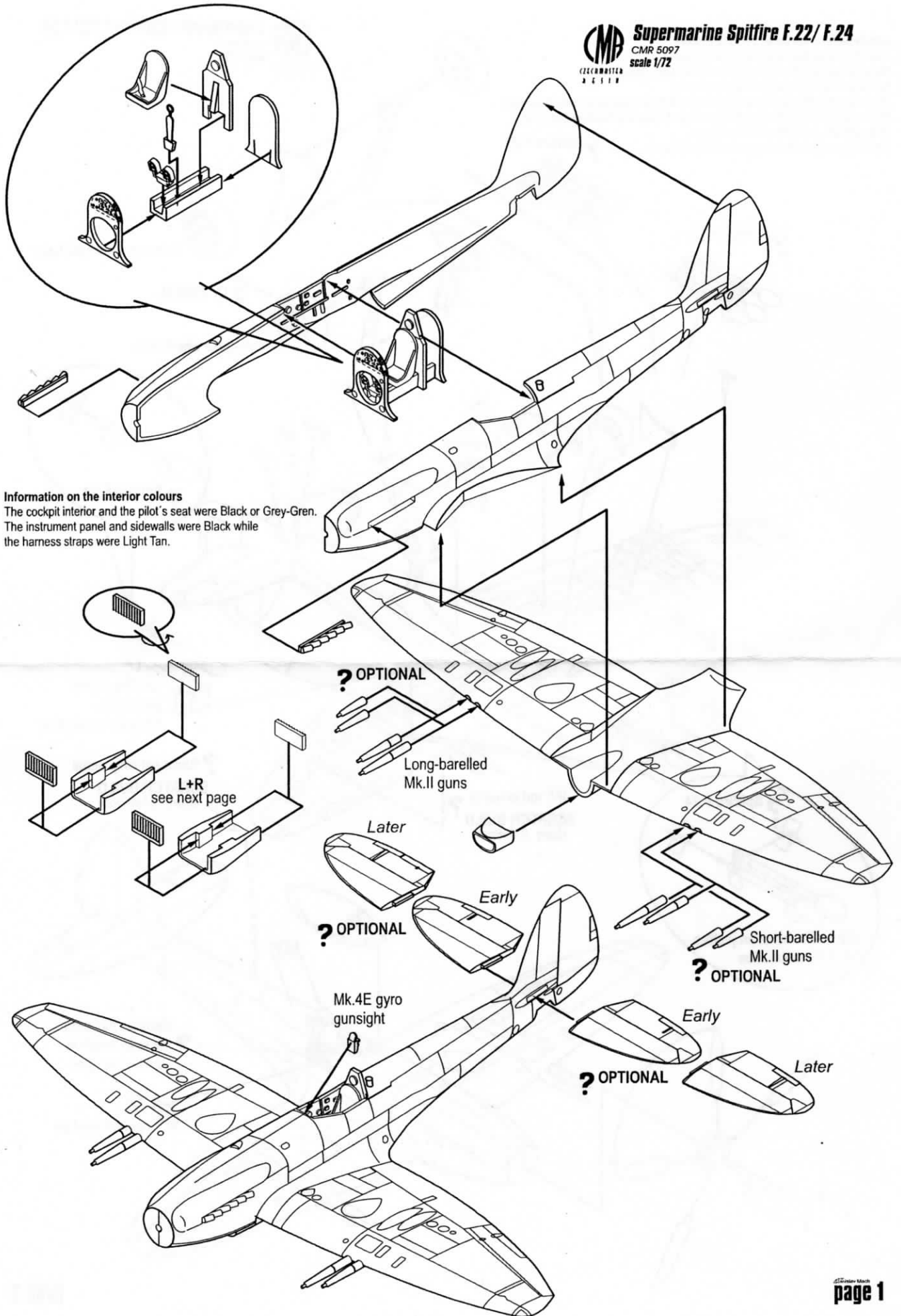

Supermarine Spitfire F.22/ F.24

CMR 5097
scale 1/72

CELEBRATING
40
YEARS



Information on the interior colours

The cockpit interior and the pilot's seat were Black or Grey-Green.
The instrument panel and sidewalls were Black while
the harness straps were Light Tan.

? OPTIONAL

Long-barelled
Mk.II guns

Later

Early

? OPTIONAL

Short-barelled
Mk.II guns

? OPTIONAL

Mk.4E gyro
gunsight

Early

? OPTIONAL

Later

L+R
see next page



Supermarine Spitfire F.22/ F.24

CMR 5097
scale 1/72

Information on the undercarriage colours

The airframe interior, wheel wells and inside of the undercarriage door covers were usually Grey-Green (on camouflaged aircraft) or Aluminium while the undercarriage legs and wheels disks were bare metal or sprayed Aluminium. The inside of the radiator intakes was either dull metal or Medium Sea Grey. The exhausts stubs were Golden Bronze. The rocket projectiles were painted in Dark Green.

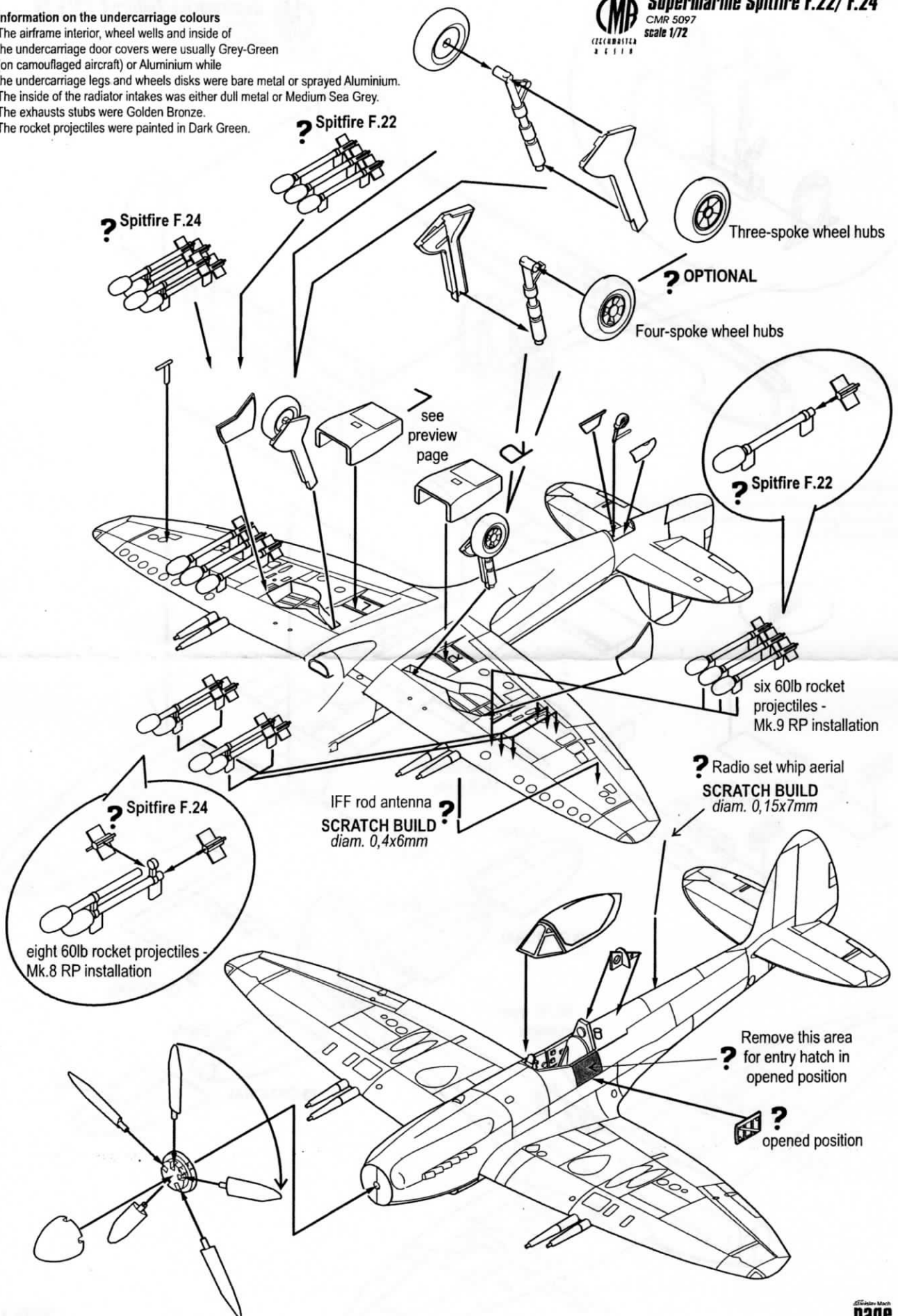

camo 1 Supermarine Spitfire F.22, PK519, V6-A, No. 615 (County of Glamorgan) Squadron, Biggin Hill, 1950

CMB Supermarine Spitfire F.22/ F.24
 CMR 5097
 scale 1/72
 CLECOMBROTHER
 2011



YELLOW

Federal Standard FS 595A colour match:

- Dark Green - FS 34079
- Ocean Grey - FS 36152
- Sea Grey Medium - FS 36270
- Sky - FS 34672
- Yellow - FS 33538

Colour code : DG
 SGM

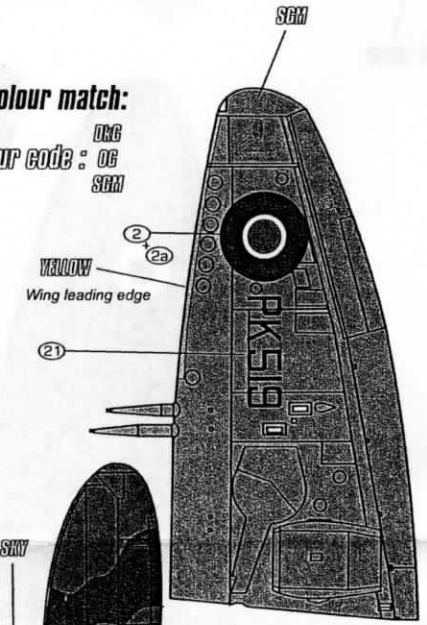
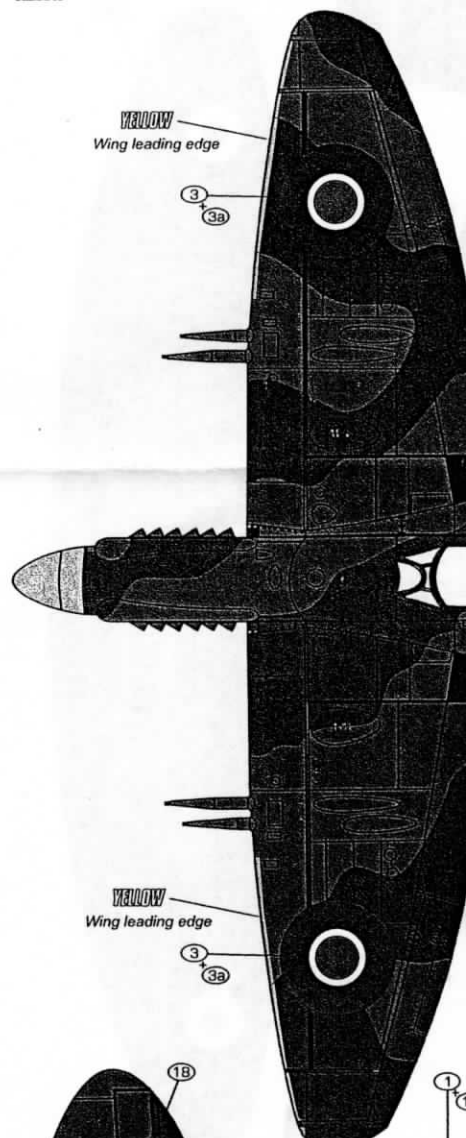

Camouflage Pattern:

Dark Green and Ocean Grey Uppersurfaces,
 Medium Sea Grey Undersurfaces. Sky rear fuselage bar.
 Yellow spinner and wing leading edges.

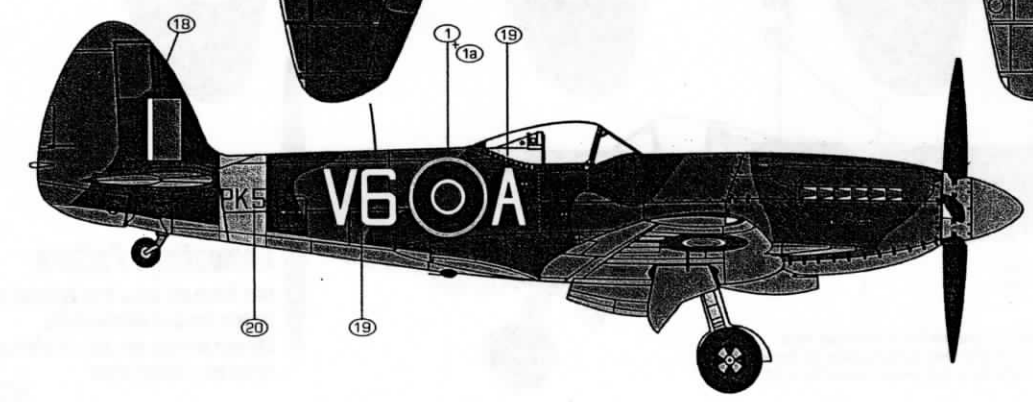

camo 2 Supermarine Spitfire F.24, VN318, W20F,
No. 80 Squadron RAF, Hong Kong Auxiliary Air Force (HKAAF)
Kai Tak, Hong Kong, 1949

CMA Supermarine Spitfire F.22/ F.24
CMR 5097
scale 1/72

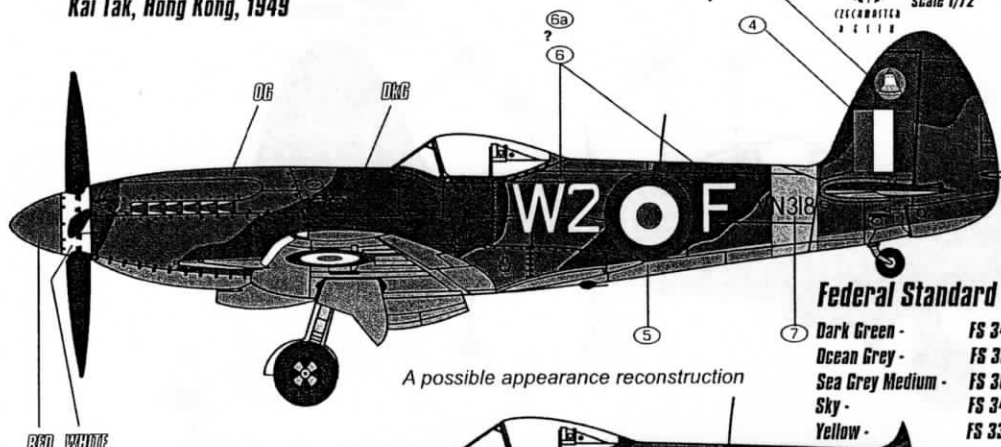

A possible appearance reconstruction

Federal Standard FS 595A colour match:

- Dark Green - FS 34079
- Ocean Grey - FS 36152
- Sea Grey Medium - FS 36270
- Sky - FS 34672
- Yellow - FS 33538

Colour code: **SEM**

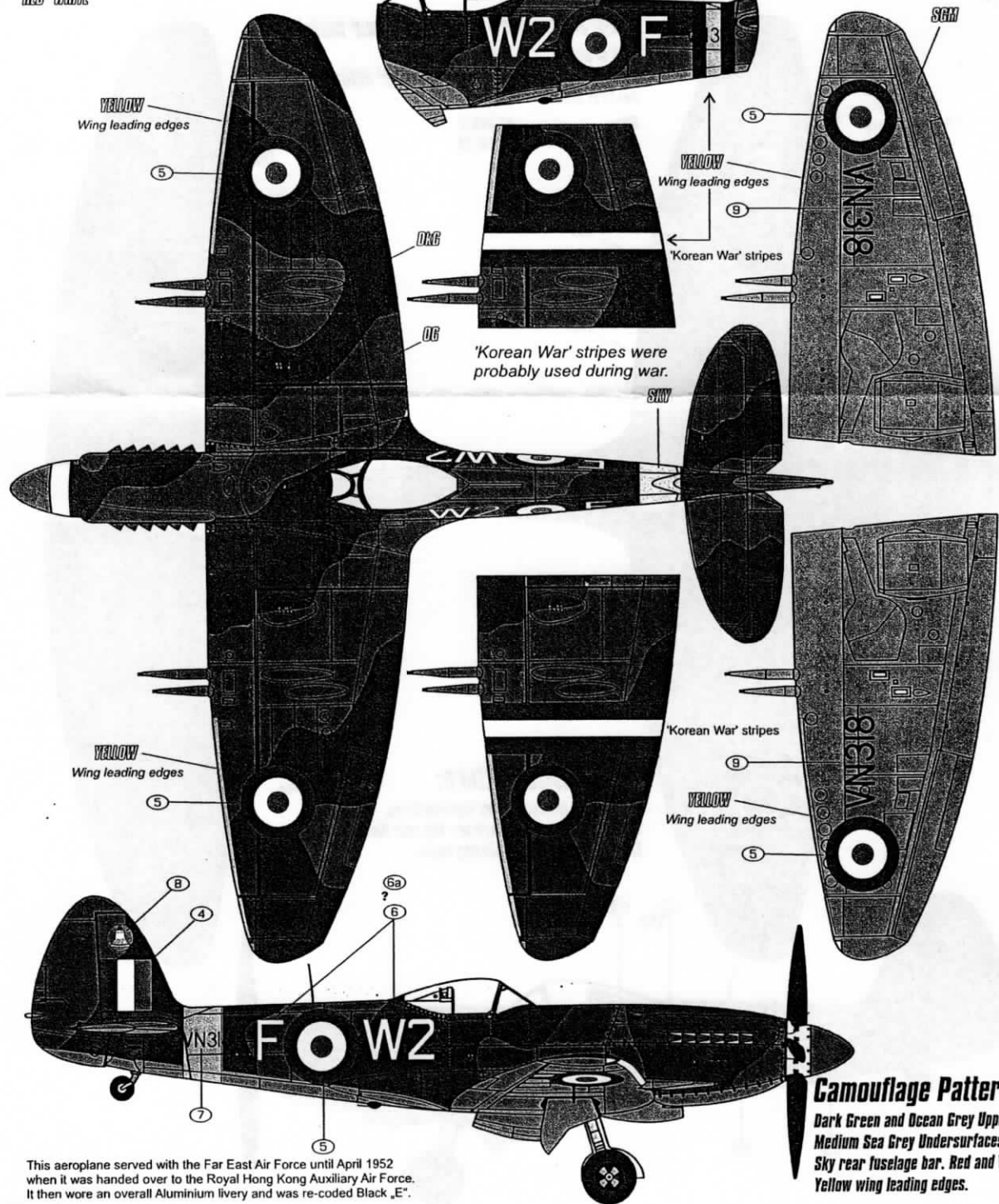

'Korean War' stripes were probably used during war.

Camouflage Pattern:

Dark Green and Ocean Grey Uppersurfaces,
Medium Sea Grey Undersurfaces.
Sky rear fuselage bar. Red and White spinner.
Yellow wing leading edges.

This aeroplane served with the Far East Air Force until April 1952 when it was handed over to the Royal Hong Kong Auxiliary Air Force. It then wore an overall Aluminium livery and was re-coded Black "E".

camo 3 Supermarine Spitfire F.24, VN318, W20E,
 Royal Hong Kong Auxiliary Air Force (RHKAAF)
 Late 1952

CMA Supermarine Spitfire F.22/ F.24
 CMR 5097
 scale 1/72
 CELEBRATED
 AESTH

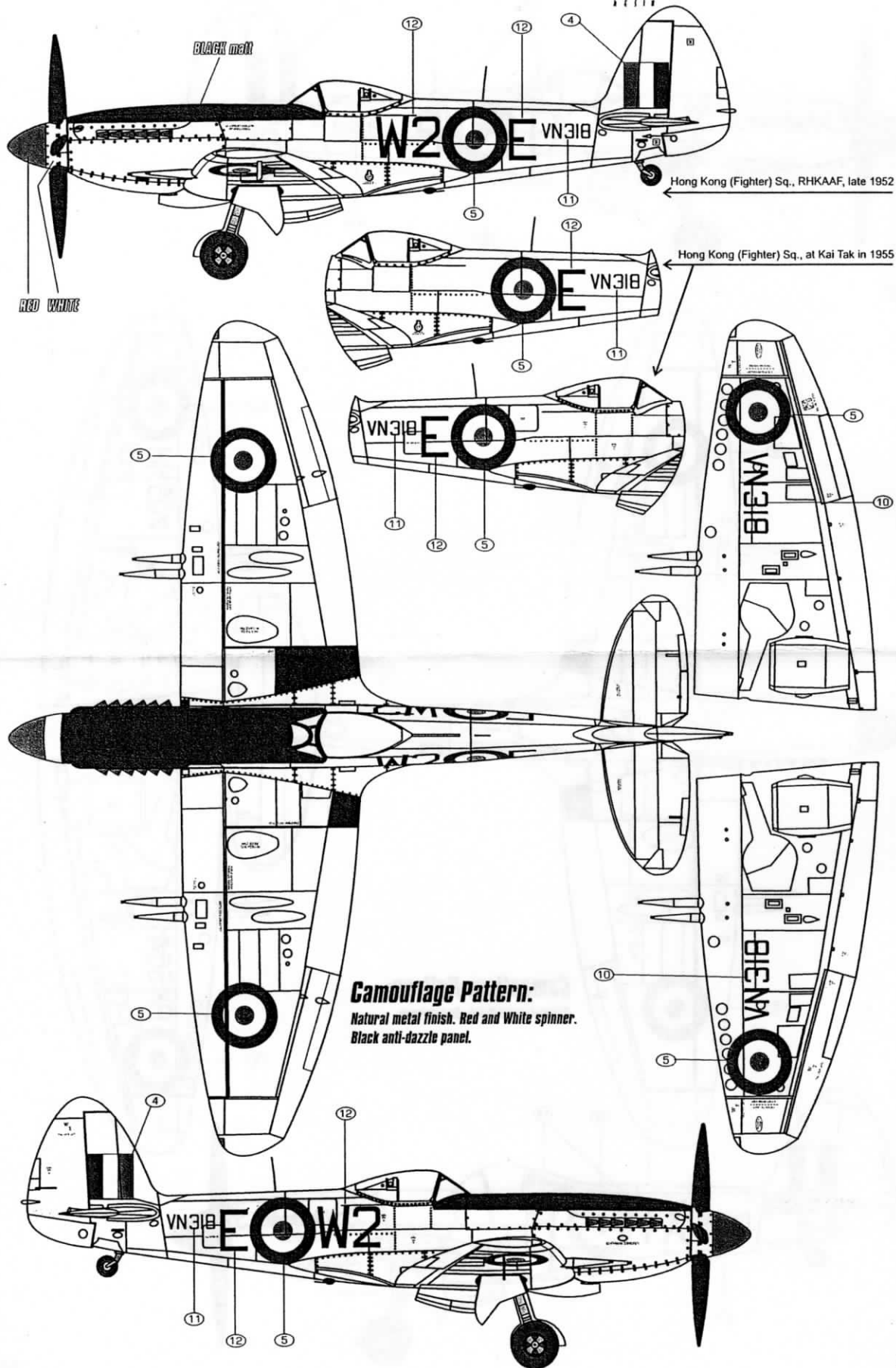

camo 4 Supermarine Spitfire F.22, PK504, XT•P,
No. 603 Squadron, Royal Auxiliary Air Force (RAuxAF),
1949-50



Supermarine Spitfire F.22/ F.24
CMR 5097
scale 1/72

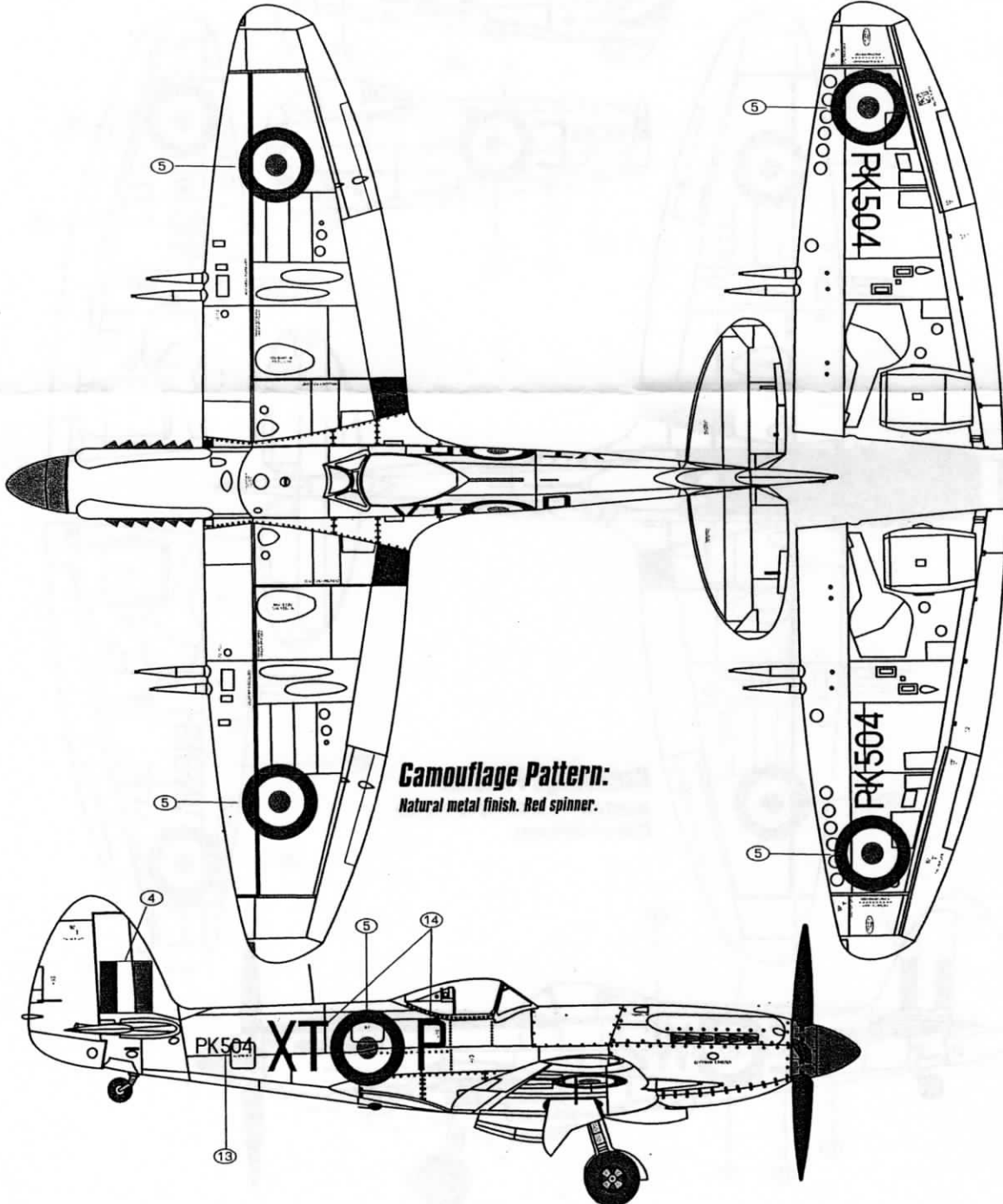
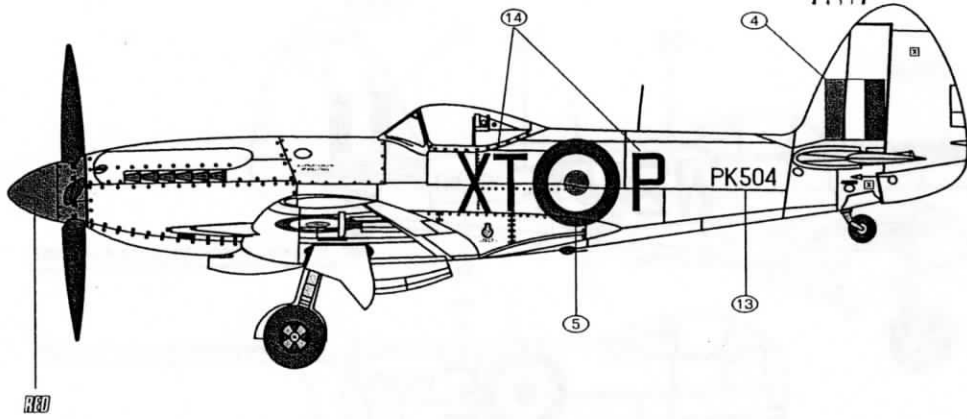

Camouflage Pattern:
Natural metal finish. Red spinner.

camo 5 Supermarine Spitfire F.22, 759,
Syrian Air Force

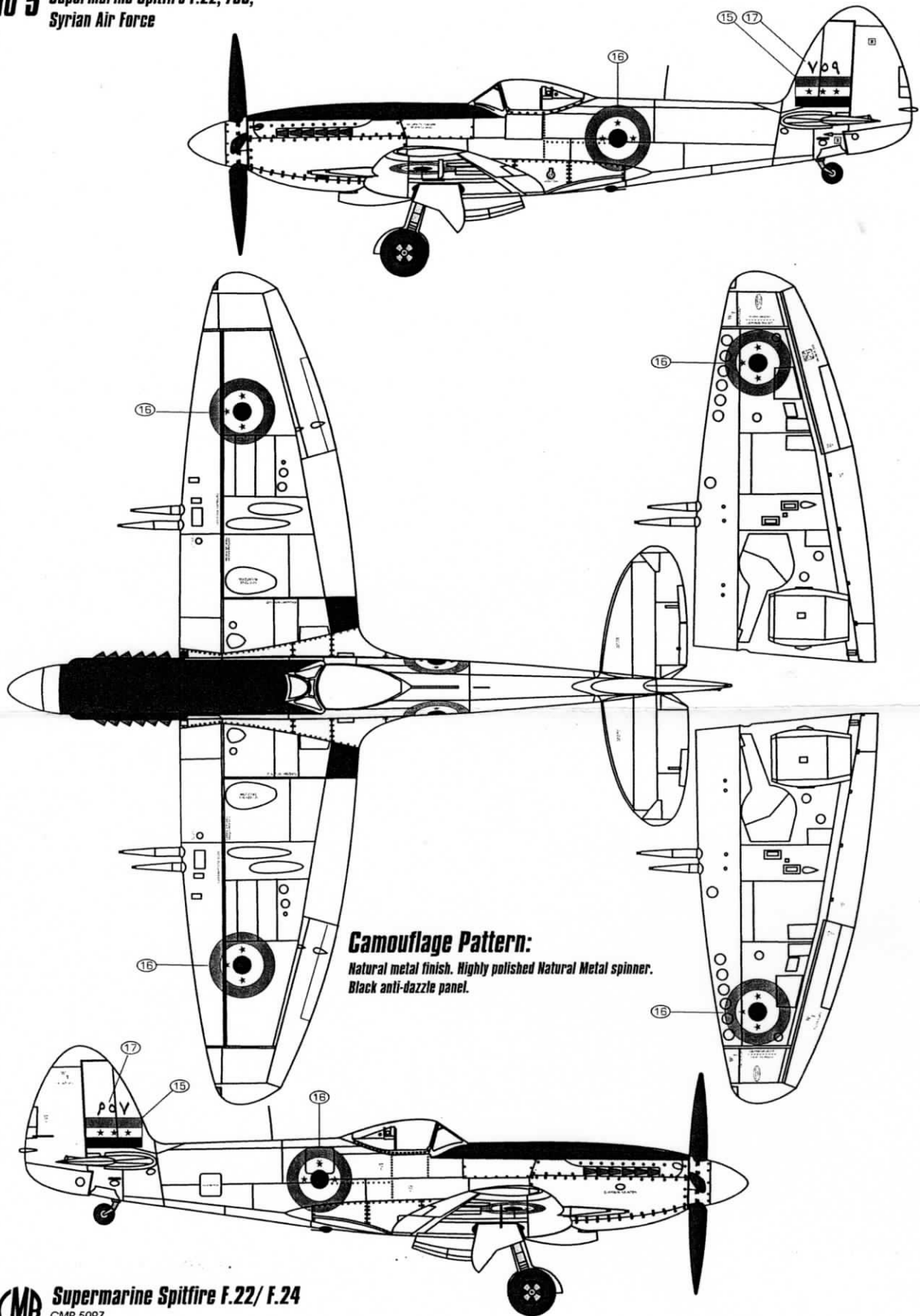

CMB Supermarine Spitfire F.22/ F.24
CMR 5097
scale 1/72

This model was prepared in collaboration with Mark I Ltd., Czech Republic
References: MARK I guide „Vickers-Supermarine Spitfire Mk.22/24“
(Catalog No. 4+ MG02)

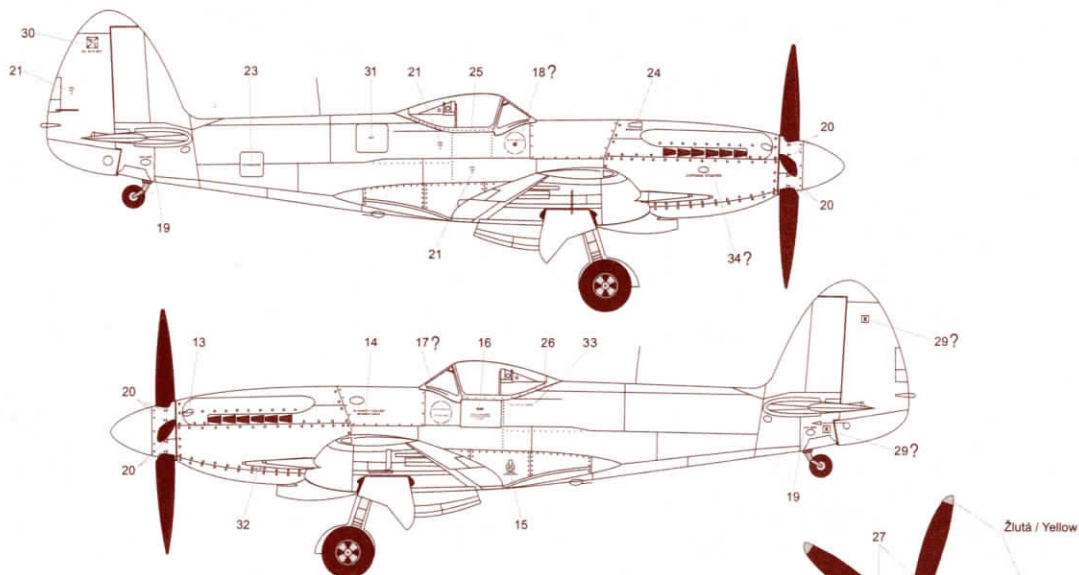

Vysvětlivky / Explanatory Note:

? Nutno vybrat vhodnou variantu popisky!
It is necessary to choose suitable stencil variant!

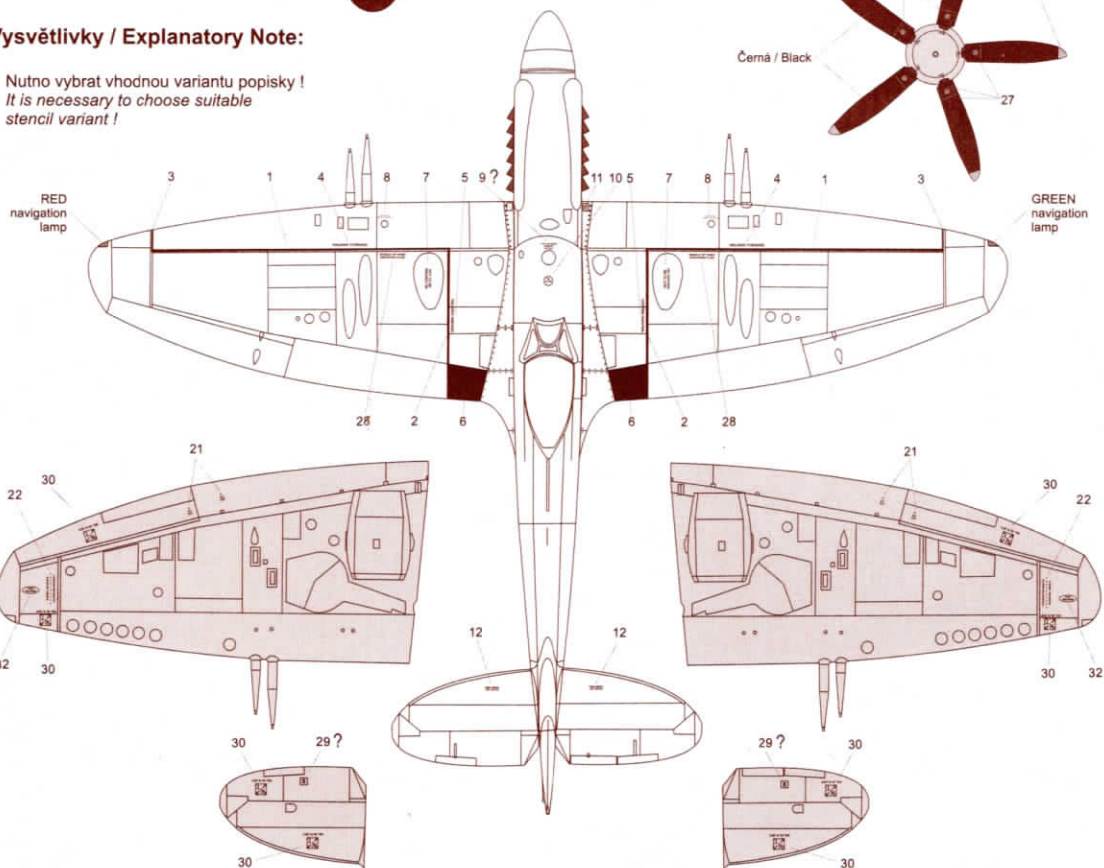
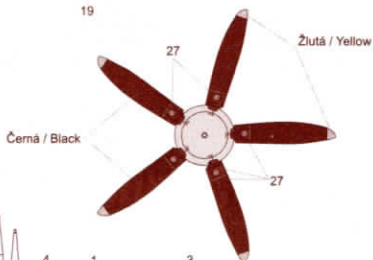

Information & contact

TALLY HO! spol. s r.o., Bojgarova 444, Ostrova-Křivsne Pole, 725 26, CZECH REPUBLIC - Europe
Tel./Fax: ++42 / 596 942 048 - E-mail: tallyho@tallyho.cz / meluzin@tallyho.cz

www.tallyho.cz

Supermarine Spitfire F.22, PK519, 615 Sqn., 1950

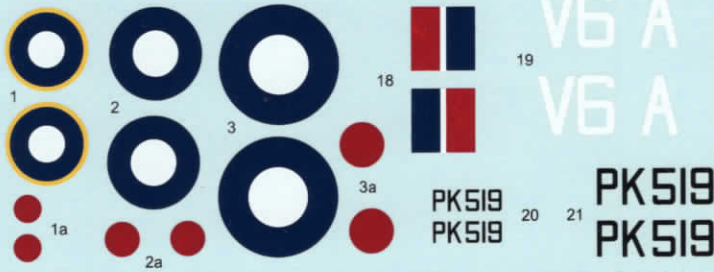

Supermarine Spitfire F.24, VN 318, W2+F, 80 Sqn., HKAAC at Kai Tak, Hong Kong, 1949



Supermarine Spitfire F.24, VN 318, E, HKAAC at Kai Tak, Hong Kong, 1955



Supermarine Spitfire F.22, "759", Syrian Air Force

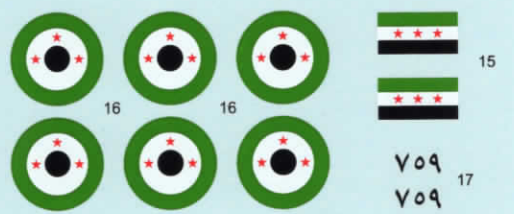

Supermarine Spitfire F.22, PK504, XT-P, 603 Sqn., RAuxF 1949-50



Supermarine Spitfire F.22 / F.24

Stencils / Popisky

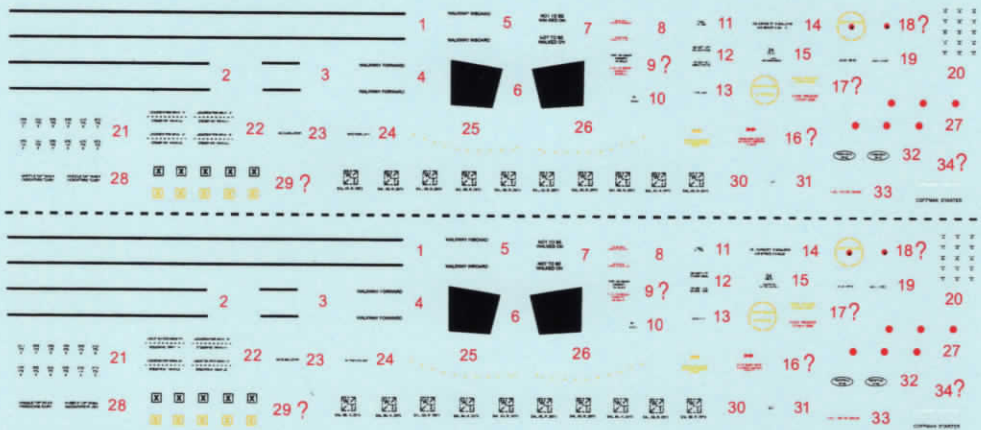

Correction !

