

ADGZ armoured car

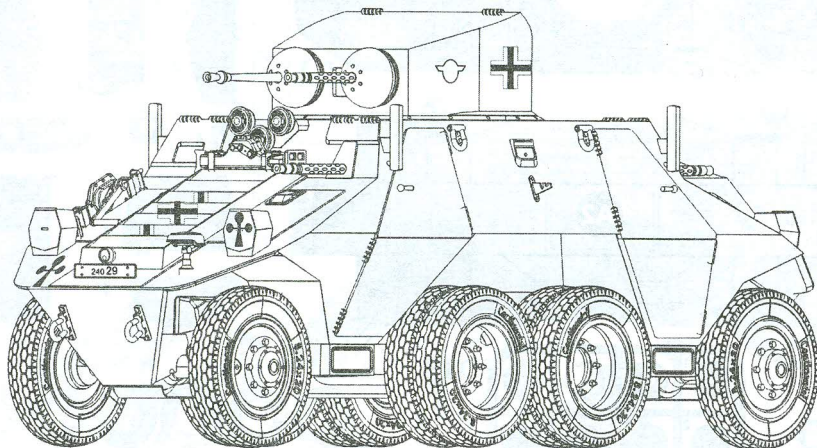

Developed by Austro-Daimler, the ADGZ armoured car, with its 8x8 wheel formula, was the first four-axle all-wheel drive military vehicle in the world and the ancestor of the new generation of heavy armoured vehicles.

Well-armoured (a 20 mm cannon and three 7.92 mm machine guns) and armour-plated (armour plates up to 15 mm), with high manoeuvrability and speed (up to 70 km/h), ADGZ M-3T were added to the SS troops' arsenal in 1939.

At the end of 1941, after successful use in Polish (1939) and French (1940) campaigns, the order on ADGZ's was placed. The cars of the late (1940) production differed with strengthened armoring of external units and new 20 mm KwK 35L/45 gun.

ADGZ-M42 armoured cars were used by the *Waffen SS* units on the Eastern Front and in Balkans (against the Marshal Tito's partisans). In March - April 1945 the garrisons of Lints and Vienna disposed of several ADGZ's.

Between 52 and 63 armoured cars of this type were produced between 1935 and 1942 accordingly to various sources.

References:

1. G. Brandford, *German early War armored fighting vehicles*, 2007
2. *Waffen Ssin colours*, vol. II wyd. Militaria № 284
3. B.Tyncherov, *Neobychnaya bronetehnika na sluzhbe obychnych prestupnikov DANZIG-SEWASTOPOL 1939-42* (Unusual armoured weapons at the service of ordinary criminals DANZIG-SEWASTOPOL 1939-42), Sevastopol publishing house, 2009.
4. M-Hobby magazine № 3/2007

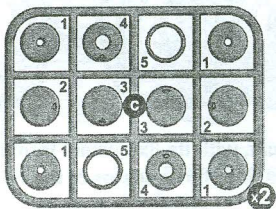
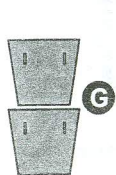
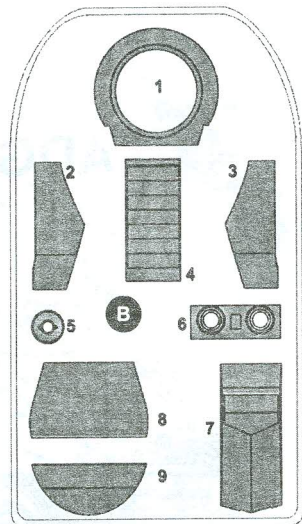
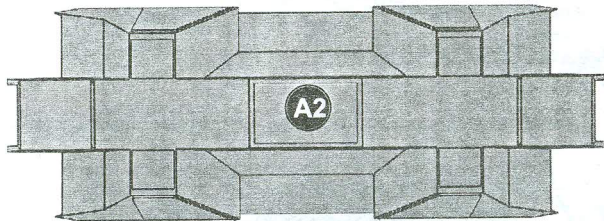
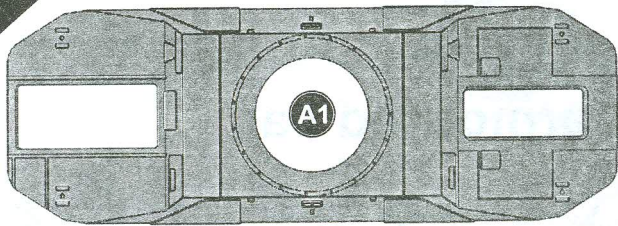

W
wire $\varnothing 1,2 \text{ l} = 30 \text{ mm}$

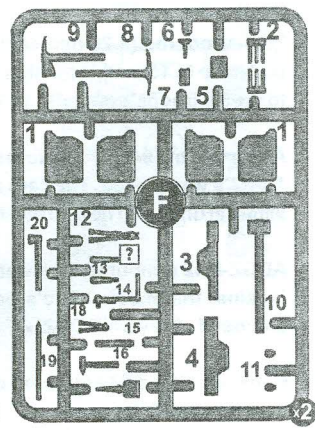
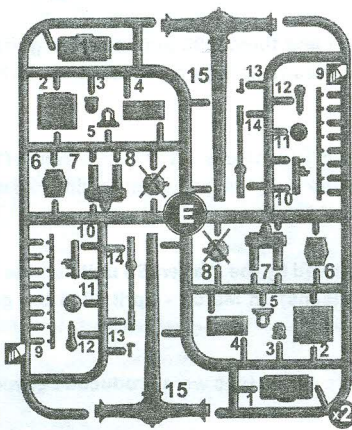
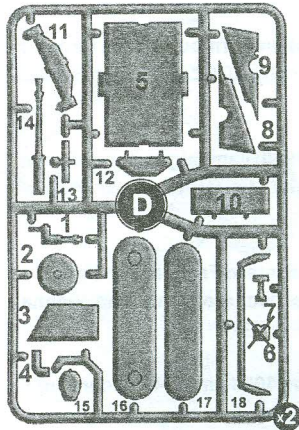
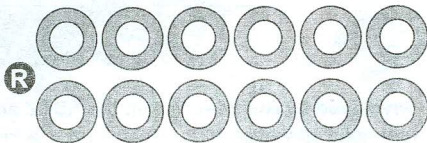

THE CONDITIONAL DENOTATION		УСЛОВНЫЕ ОБОЗНАЧЕНИЯ	
	BE CAREFUL ОСТОРОЖНО		DON'T CEMENT НЕ КЛЕИТЬ
	OPTIONAL НЕОБЯЗАТЕЛЬНО		REMOVE РЕЗАТЬ
	BEND СОГНУТЬ		SYMMETRICAL СИММЕТРИЧНО
	OPEN WHOLE СВЕРЛИТЬ		CEMENT КЛЕИТЬ
		x2 MAKE TWO УДОБИТЬ	

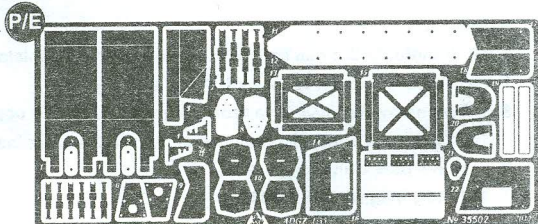

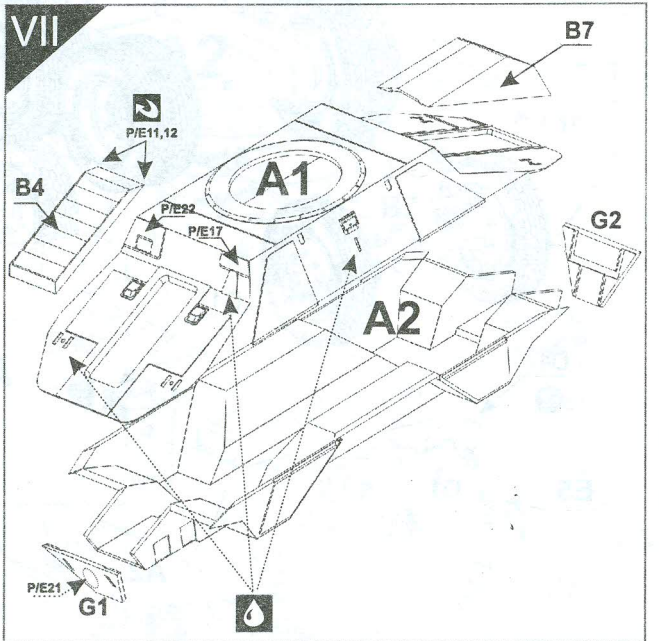
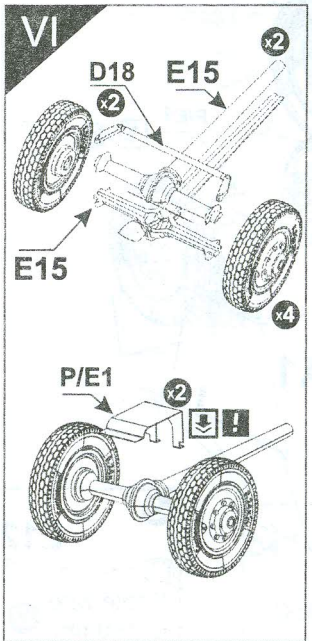
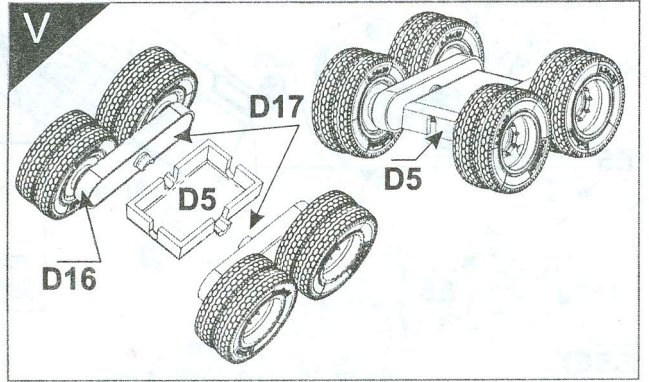
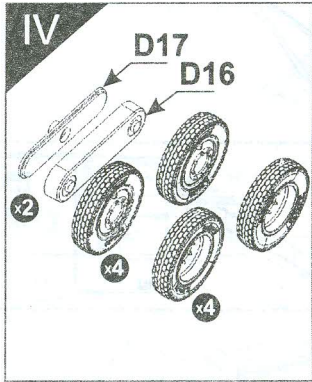
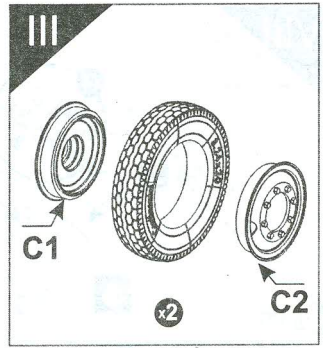
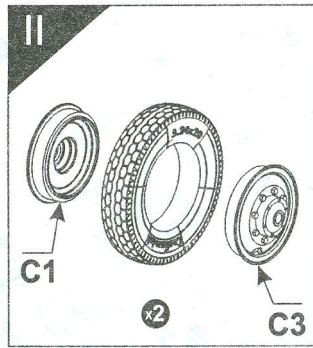
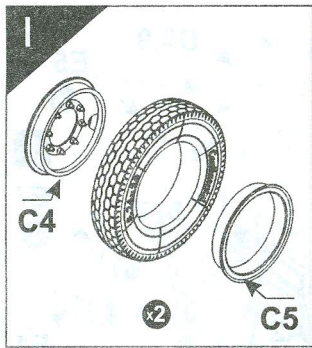

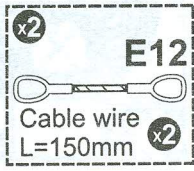
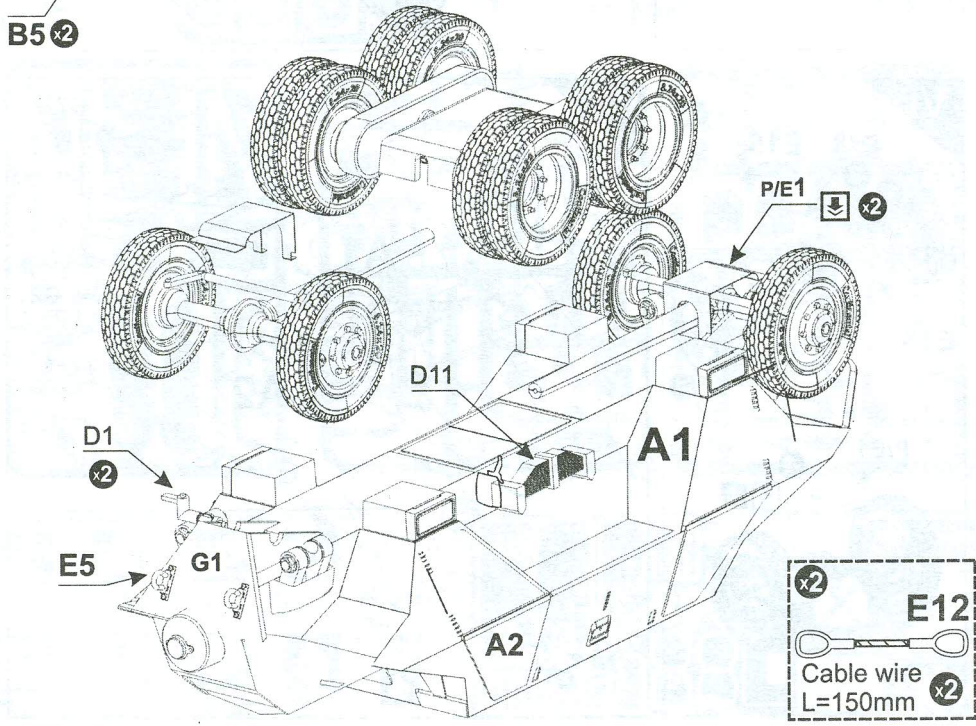
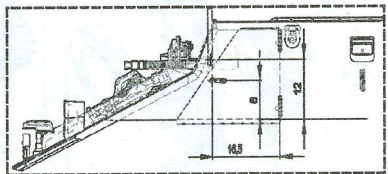
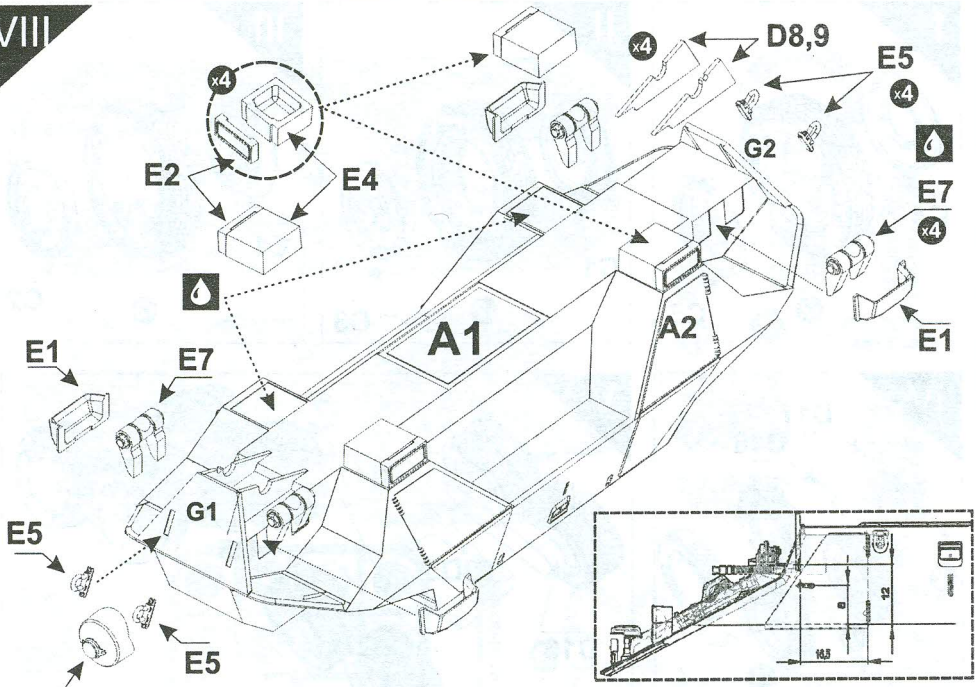

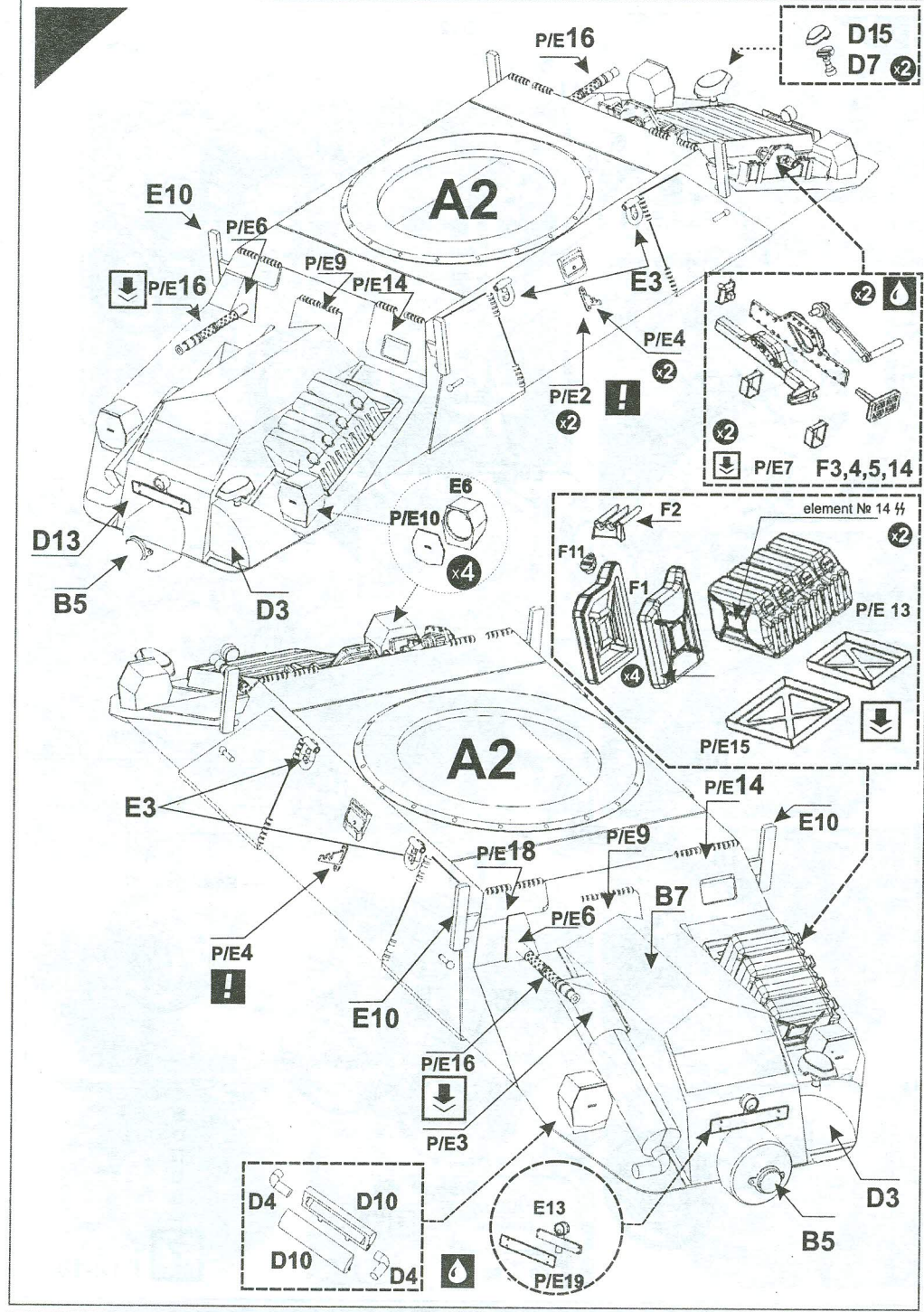

IX

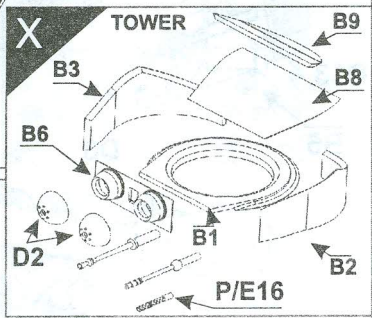
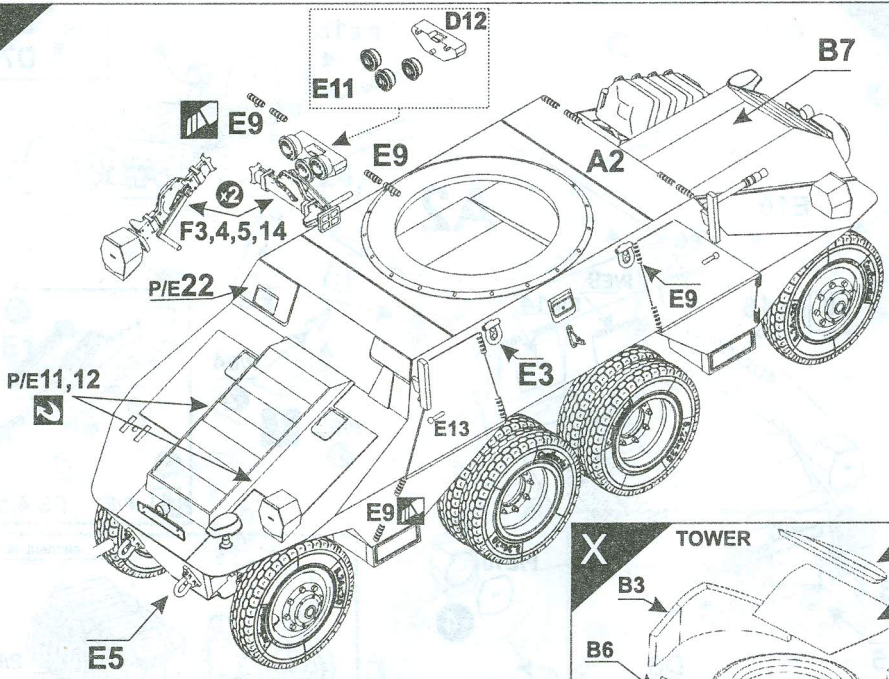

XI

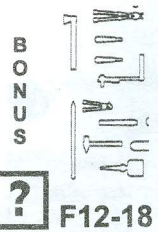
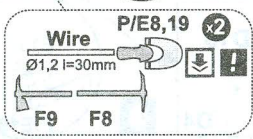
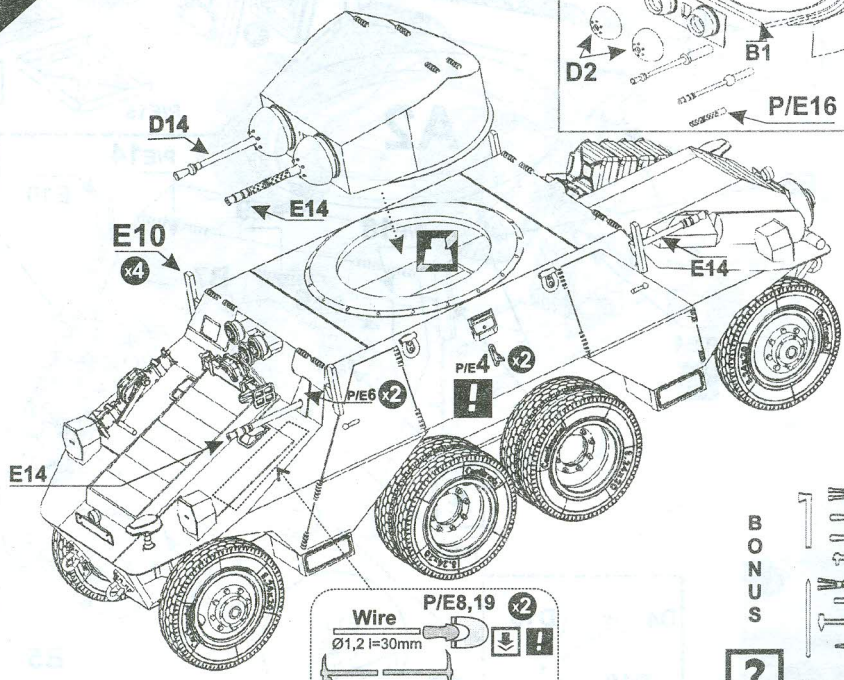

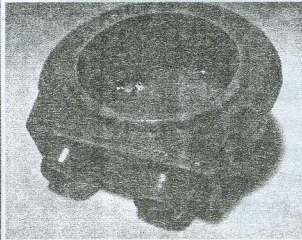
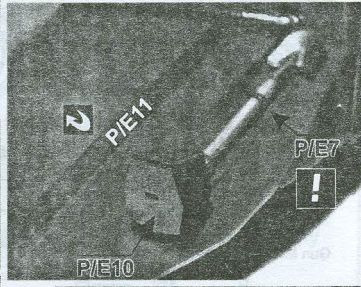
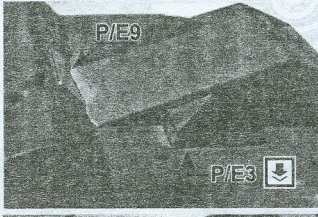
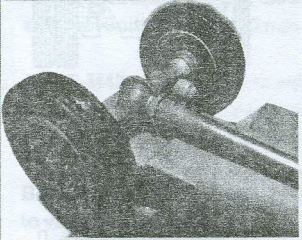
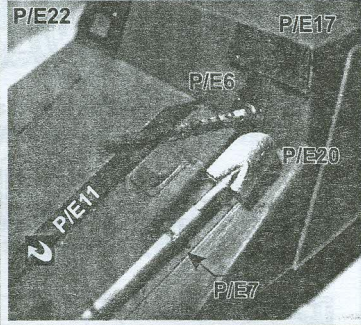
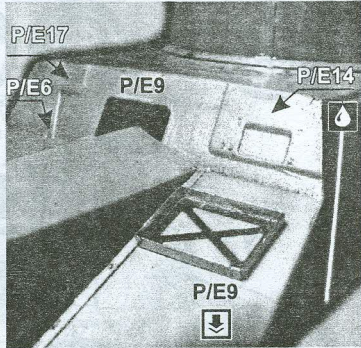
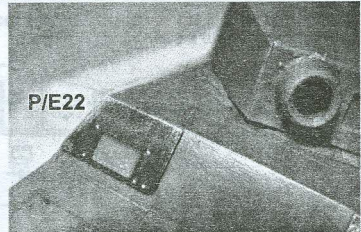
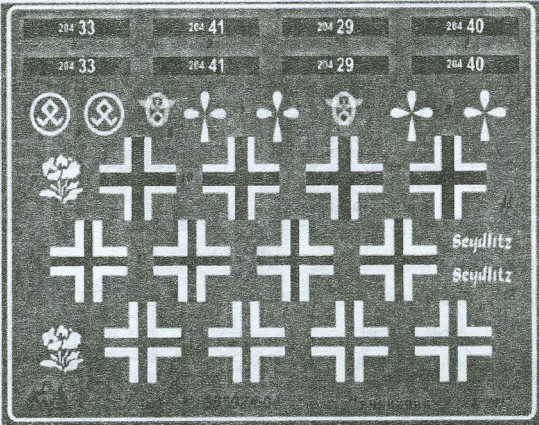

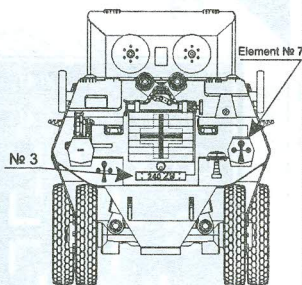
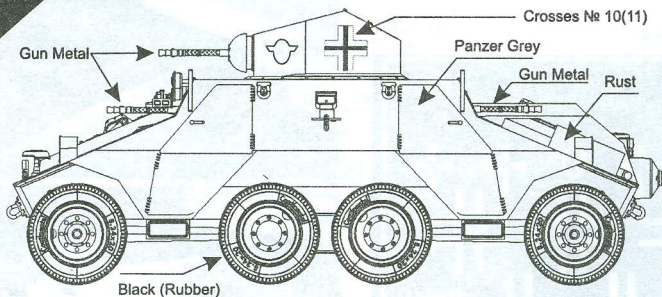

Side №204-40 Hpt. Koch Regenber

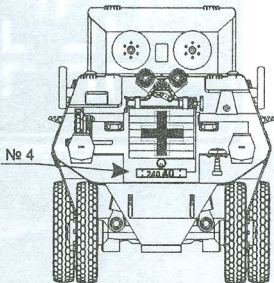
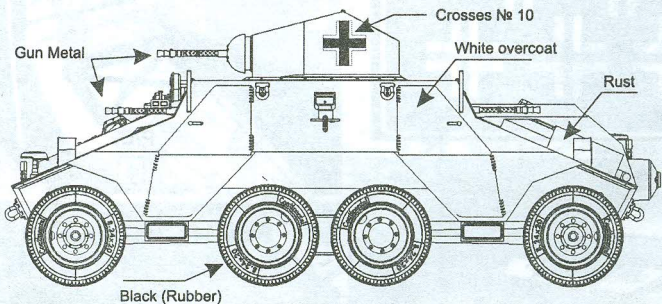

Side №204-41 Unit Unknown 1942-45.

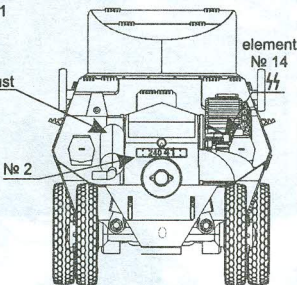
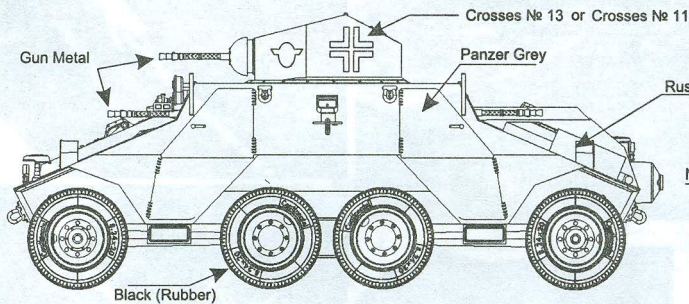

Side «Seydlits» 7-th SS-Freiwillige Gebirgs Division "Prinz Eugen", Yugoslavia 1943.

