

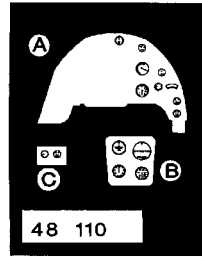

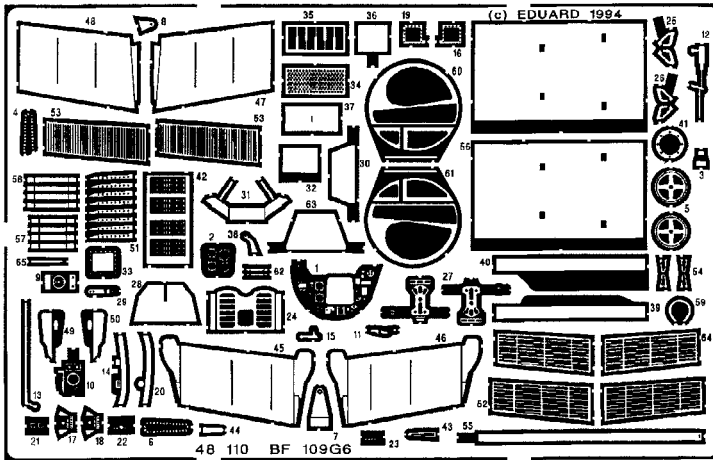



Messerschmitt Bf 109G 6

1/48th scale detail set for FUJIMI kit

48 110



-  OPPOSITE SIDE
-  REMOVE
-  BEND

INSTRUMENT PANEL

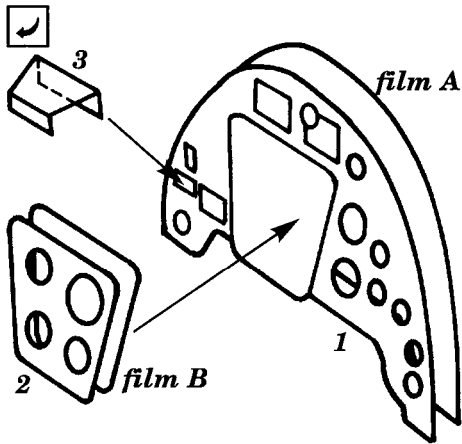

LEFT SIDE

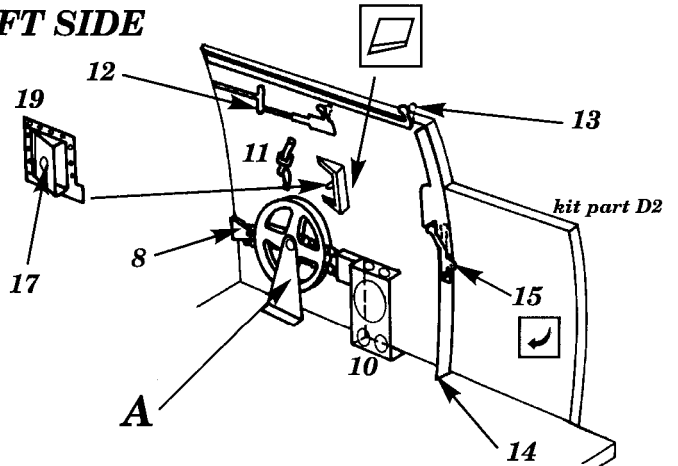

A FLAP CONTROL MECHANISM

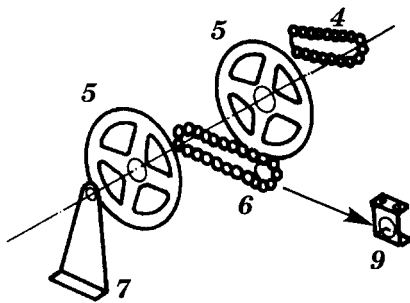

RIGHT SIDE

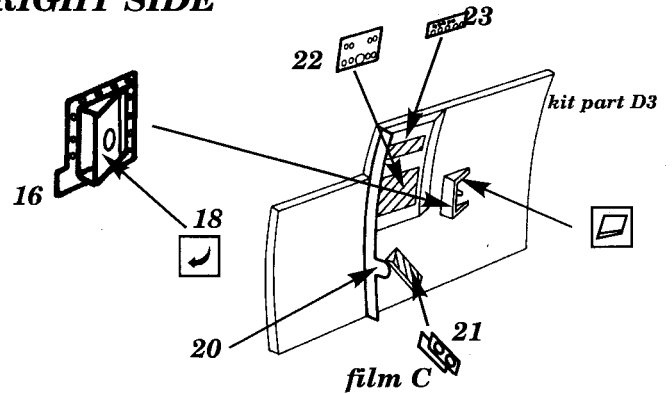

FLOOR, RUDDER PEDALS

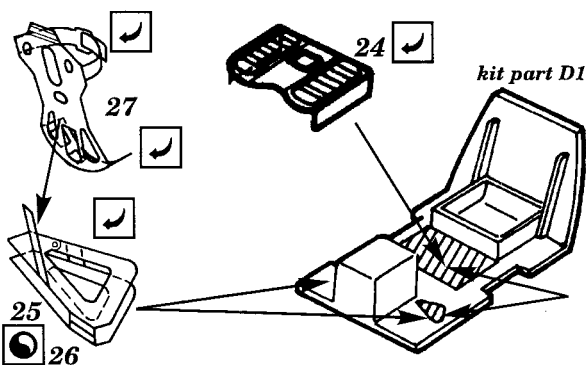

ARMOURED HEADREST

later

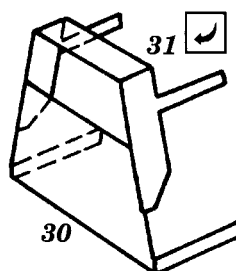

early

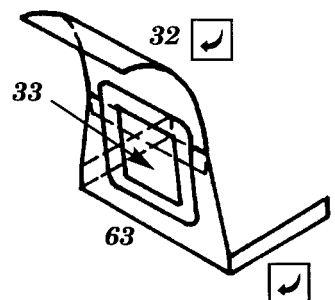

COCKPIT HOLDERS

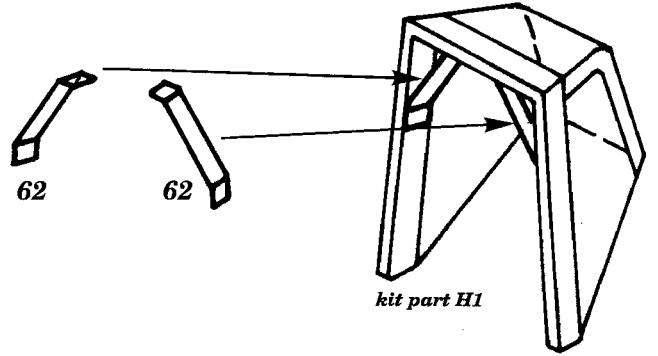
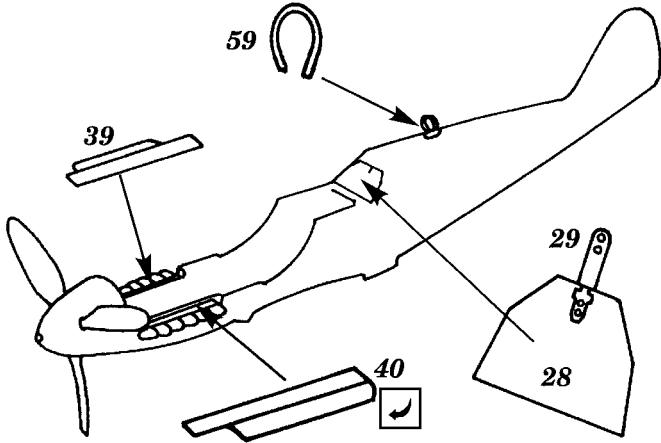

OIL COOLER

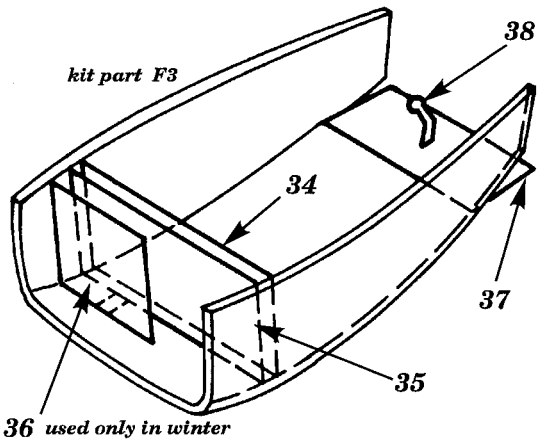

WING RADIATORS

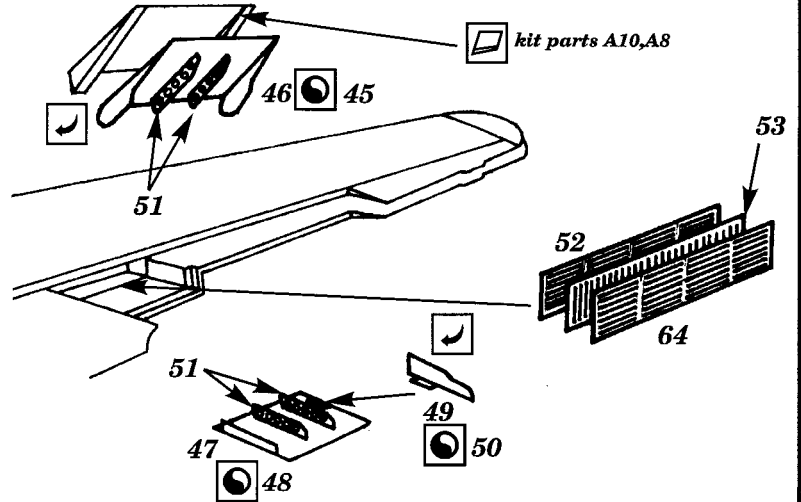

TROPICAL DUST FILTER

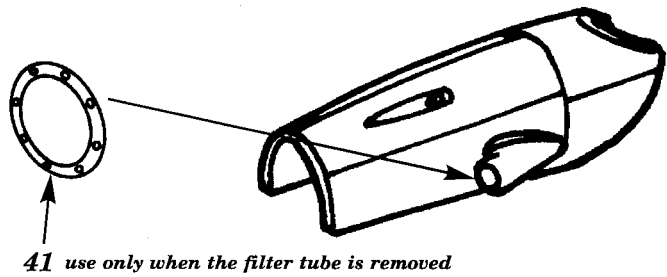
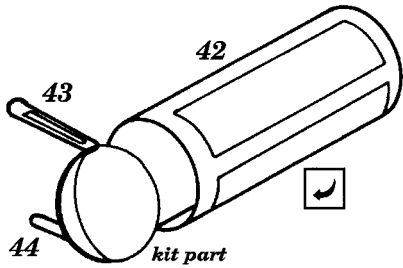

B DROP TANK BELLY

